

# 具有功率限制功能的 LM5069 正电压热插拔和浪涌电流控制器

## 1 特性

- 宽工作电压范围：9V 至 80V
- 浪涌电流限制，用于将电路板安全插入带电电源
- 外部导通器件中的可编程最大功耗
- 可调节电流限制
- 针对严重过流事件的断路器功能
- 适用于外部 N 沟道 MOSFET 的内部高侧电荷泵和栅极驱动器
- 可调节欠压锁定 (UVLO) 和迟滞
- 可调节过压锁定 (OVLO) 和迟滞
- 初始插入计时器可使振铃和瞬变在系统连接之后消除
- 可编程故障计时器可避免干扰性跳变
- 高电平有效、开漏电源正常状态输出
- 提供故障锁存和自动重启版本
- 10 引脚 VSSOP 封装

## 2 应用

- 服务器背板系统
- 基站配电系统
- 固态断路器
- 24V 和 48V 工业系统

## 3 说明

LM5069 正电压热插拔控制器可在从带电系统背板或其他热插拔电源插入和移除电路板期间，为电源连接提供智能控制。LM5069 可提供浪涌电流控制以限制系统电压下降和瞬变。外部串行导通 N 沟道 MOSFET 中的电流限制和功率耗散可进行编程，从而确保其在安全工作区 (SOA) 内工作。当输出电压低于 1.25V 输入电压时，会显示电源正常输出。输入欠压和过压锁定电平和迟滞，以及初始插入延迟时间和故障监测时间均可进行编程。在故障监测之后 LM5069-1 闭锁，同时 LM5069-2 以固定占空比自动重启。LM5069 采用 10 引脚 VSSOP 封装。

### 器件信息(1)

| 器件型号   | 封装         | 封装尺寸 (标称值)      |
|--------|------------|-----------------|
| LM5069 | VSSOP (10) | 3.00mm × 3.00mm |

(1) 如需了解所有可用封装，请参阅数据表末尾的可订购产品附录。

典型应用图

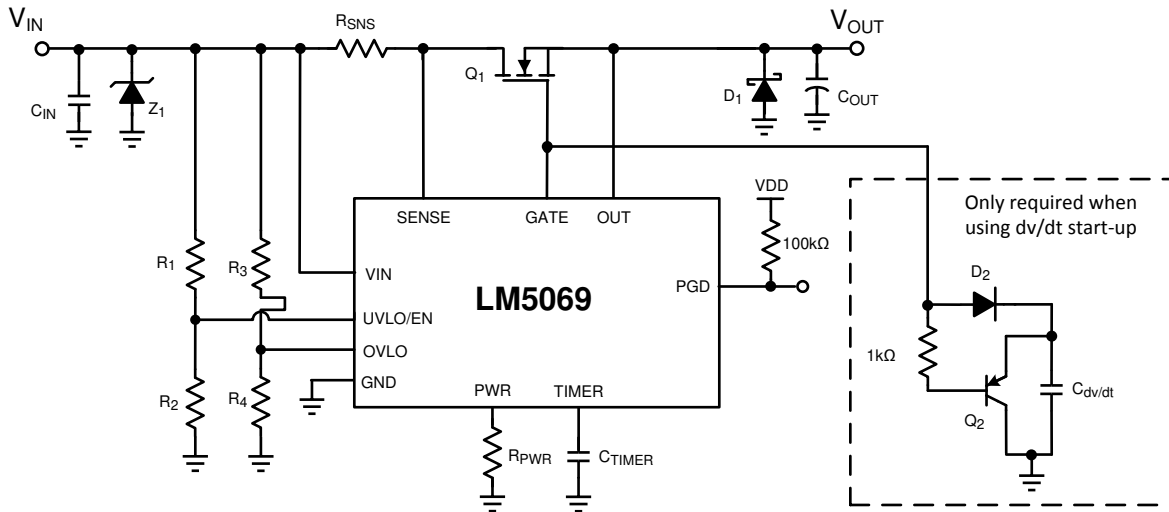

## 目录

|          |  |           |           |   |           |
|----------|--|-----------|-----------|---|-----------|
| 1        | 特性 .....                                     | 1         | 8.4       | Device Functional Modes .....               | 13        |
| 2        | 应用 .....                                     | 1         | <b>9</b>  | <b>Application and Implementation</b> ..... | <b>17</b> |
| 3        | 说明 .....                                     | 1         | 9.1       | Application Information .....               | 17        |
| 4        | 修订历史记录 .....                                 | 2         | 9.2       | Typical Application .....                   | 17        |
| 5        | <b>Device Comparison</b> .....               | <b>3</b>  | <b>10</b> | <b>Power Supply Recommendations</b> .....   | <b>27</b> |
| 6        | <b>Pin Configuration and Functions</b> ..... | <b>3</b>  | <b>11</b> | <b>Layout</b> .....                         | <b>28</b> |
| 7        | <b>Specifications</b> .....                  | <b>4</b>  | 11.1      | Layout Guidelines .....                     | 28        |
| 7.1      | Absolute Maximum Ratings .....               | 4         | 11.2      | Layout Example .....                        | 29        |
| 7.2      | ESD Ratings .....                            | 4         | <b>12</b> | <b>器件和文档支持</b> .....                        | <b>31</b> |
| 7.3      | Recommended Operating Conditions .....       | 4         | 12.1      | 器件支持 .....                                  | 31        |
| 7.4      | Thermal Information .....                    | 4         | 12.2      | 文档支持 .....                                  | 31        |
| 7.5      | Electrical Characteristics .....             | 5         | 12.3      | 接收文档更新通知 .....                              | 31        |
| 7.6      | Typical Characteristics .....                | 7         | 12.4      | 社区资源 .....                                  | 31        |
| <b>8</b> | <b>Detailed Description</b> .....            | <b>11</b> | 12.5      | 商标 .....                                    | 31        |
| 8.1      | Overview .....                               | 11        | 12.6      | 静电放电警告 .....                                | 31        |
| 8.2      | Functional Block Diagram .....               | 11        | 12.7      | Glossary .....                              | 31        |
| 8.3      | Feature Description .....                    | 12        | <b>13</b> | <b>机械、封装和可订购信息</b> .....                    | <b>31</b> |

## 4 修订历史记录

注：之前版本的页码可能与当前版本有所不同。

| <b>Changes from Revision F (February 2019) to Revision G</b> | <b>Page</b> |
|--|-------------|
| • Added <i>Device Comparison</i> table .....                 | <b>3</b>    |

| <b>Changes from Revision E (November 2016) to Revision F</b> | <b>Page</b> |
|--|-------------|
| • Updated the <i>Absolute Maximum Ratings</i> section .....  | <b>4</b>    |

  

| <b>Changes from Revision D (May 2013) to Revision E</b>                                | <b>Page</b> |
|--|-------------|
| • 已添加 <i>ESD</i> 额定值表，特性说明部分，器件功能模式，应用和实施部分，电源建议部分，布局部分，器件和文档支持部分以及机械、封装和可订购信息部分 ..... | <b>1</b>    |
| • Added <i>Thermal Information</i> table .....   | <b>4</b>    |

## 5 Device Comparison

| DEVICE NUMBER | RETRY BEHAVIOR AFTER FAULT | PACKAGE    |
|---------------|----------------------------|------------|
| LM5069-1      | Latch Off on Fault         | VSSOP (10) |
| LM5069-2      | Auto Retry on Fault        |            |

## 6 Pin Configuration and Functions

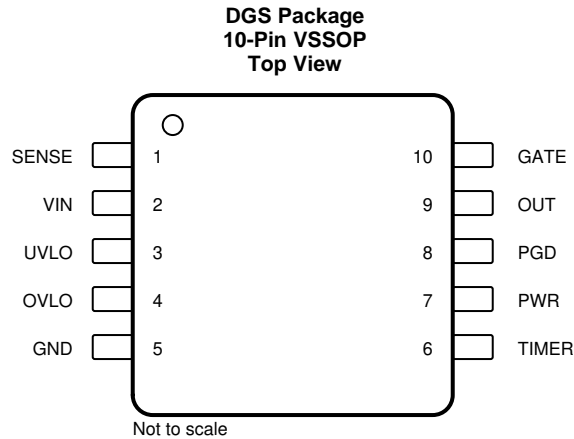

### Pin Functions

| PIN |       | I/O | DESCRIPTION   |
|-----|-------|-----|---|
| NO. | NAME  |     |   |
| 1   | SENSE | I   | Current sense input: The voltage across the current sense resistor ( $R_S$ ) is measured from VIN to this pin. If the voltage across $R_S$ reaches 55 mV the load current is limited and the fault timer activates.   |
| 2   | VIN   | I   | Positive supply input: A small ceramic bypass capacitor close to this pin is recommended to suppress transients which occur when the load current is switched off.  |
| 3   | UVLO  | I   | Undervoltage lockout: An external resistor divider from the system input voltage sets the undervoltage turnon threshold. An internal 21- $\mu$ A current source provides hysteresis. The enable threshold at the pin is 2.5 V. This pin can also be used for remote shutdown control. |
| 4   | OVLO  | I   | Overvoltage lockout: An external resistor divider from the system input voltage sets the overvoltage turnoff threshold. An internal 21- $\mu$ A current source provides hysteresis. The disable threshold at the pin is 2.5 V.  |
| 5   | GND   | —   | Circuit ground  |
| 6   | TIMER | I/O | Timing capacitor: An external capacitor connected to this pin sets the insertion time delay and the fault timeout period. The capacitor also sets the restart timing of the LM5069-2.   |
| 7   | PWR   | I   | Power limit set: An external resistor connected to this pin, in conjunction with the current sense resistor ( $R_S$ ), sets the maximum power dissipation allowed in the external series pass MOSFET.   |
| 8   | PGD   | O   | Power Good indicator: An open drain output. When the external MOSFET $V_{DS}$ decreases below 1.25 V, the PGD indicator is active (high). When the external MOSFET $V_{DS}$ increases above 2.5 V the PGD indicator switches low.   |
| 9   | OUT   | I   | Output feedback: Connect to the output rail (external MOSFET source). Internally used to determine the MOSFET $V_{DS}$ voltage for power limiting, and to control the PGD indicator.  |
| 10  | GATE  | O   | Gate drive output: Connect to the external MOSFET's gate. This pin's voltage is typically 12 V above the OUT pin when enabled.  |

## 7 Specifications

### 7.1 Absolute Maximum Ratings

over operating free-air temperature range (unless otherwise noted)<sup>(1)(2)</sup>

|   | MIN  | MAX | UNIT |
|---|------|-----|------|
| VIN to GND <sup>(3)</sup>                       | -0.3 | 100 | V    |
| SENSE, OUT, and PGD to GND                      | -0.3 | 100 | V    |
| GATE to GND <sup>(3)</sup>                      | -0.3 | 100 | V    |
| OUT to GND (1 -ms transient) <sup>(4)</sup>     | -1   | 100 | V    |
| UVLO to GND                                     | -0.3 | 100 | V    |
| OVLO to GND                                     | -0.3 | 7   | V    |
| VIN to SENSE                                    | -0.3 | 0.3 | V    |
| Maximum junction temperature, T <sub>JMAX</sub> |      | 150 | °C   |
| Storage temperature, T <sub>stg</sub>           | -65  | 150 | °C   |

- (1) Stresses beyond those listed under *Absolute Maximum Ratings* may cause permanent damage to the device. These are stress ratings only, which do not imply functional operation of the device at these or any other conditions beyond those indicated under *Recommended Operating Conditions*. Exposure to absolute-maximum-rated conditions for extended periods may affect device reliability.
- (2) If Military/Aerospace specified devices are required, please contact the Texas Instruments Sales Office/ Distributors for availability and specifications.
- (3) The GATE pin voltage is typically 12 V above VIN when the LM5069 is enabled. Therefore, the Absolute Maximum Ratings for VIN (100 V) applies only when the LM5069 is disabled, or for a momentary surge to that voltage because the Absolute Maximum Rating for the GATE pin is also 100 V.
- (4) Select external MOSFET with VGS(th) voltage higher than V<sub>OUT</sub> during -ve transient. This avoids MOSFET getting turned-ON during -ve transient.

### 7.2 ESD Ratings

|   |  | VALUE | UNIT |
|---|--|-------|------|
| V <sub>(ESD)</sub> Electrostatic discharge <sup>(1)</sup> | Human-body model (HBM), per ANSI/ESDA/JEDEC JS-001 <sup>(2)</sup>              | ±2000 | V    |
|   | Charged-device model (CDM), per JEDEC specification JESD22-C101 <sup>(3)</sup> | ±500  |      |

- (1) The Human-body model is a 100-pF capacitor discharged through a 1.5-kΩ resistor into each pin.
- (2) JEDEC document JEP155 states that 500-V HBM allows safe manufacturing with a standard ESD control process.
- (3) JEDEC document JEP157 states that 250-V CDM allows safe manufacturing with a standard ESD control process.

### 7.3 Recommended Operating Conditions

over operating free-air temperature range (unless otherwise noted)<sup>(1)</sup>

|                |                      | MIN | MAX | UNIT |
|----------------|----------------------|-----|-----|------|
| VIN            | Supply voltage       | 9   | 80  | V    |
|                | PGD off voltage      | 0   | 80  | V    |
| T <sub>J</sub> | Junction temperature | -40 | 125 | °C   |

- (1) For detailed information on soldering plastic VSSOP packages, see [Absolute Maximum Ratings for Soldering](#) (SNOA549) available from Texas Instruments.

### 7.4 Thermal Information

| THERMAL METRIC <sup>(1)</sup> |  | LM5069      | UNIT |
|-------------------------------|--|-------------|------|
|                               |  | DGS (VSSOP) |      |
|                               |  | 10 PINS     |      |
| R <sub>θJA</sub>              | Junction-to-ambient thermal resistance       | 156         | °C/W |
| R <sub>θJC(top)</sub>         | Junction-to-case (top) thermal resistance    | 50.6        | °C/W |
| R <sub>θJB</sub>              | Junction-to-board thermal resistance         | 75.8        | °C/W |
| ψ <sub>JT</sub>               | Junction-to-top characterization parameter   | 4.8         | °C/W |
| ψ <sub>JB</sub>               | Junction-to-board characterization parameter | 74.5        | °C/W |
| R <sub>θJC(bot)</sub>         | Junction-to-case (bottom) thermal resistance | —           | °C/W |

- (1) For more information about traditional and new thermal metrics, see the [Semiconductor and IC Package Thermal Metrics](#) application report.

## 7.5 Electrical Characteristics

Minimum and maximum limits are specified through test, design, or statistical correlation at  $T_J = -40^{\circ}\text{C}$  to  $125^{\circ}\text{C}$ . Typical values represent the most likely parametric norm at  $T_J = 25^{\circ}\text{C}$  and are provided for reference purposes only.  $V_{IN} = 48\text{ V}$  (unless otherwise noted).

| PARAMETER                      |  | TEST CONDITIONS  | MIN  | TYP | MAX  | UNIT          |
|--------------------------------|--|--|------|-----|------|---------------|
| <b>INPUT (VIN PIN)</b>         |  |  |      |     |      |               |
| $I_{IN-EN}$                    | Input current, enabled                                     | UVLO > 2.5 V and OVLO < 2.5 V  |      | 1.3 | 1.6  | mA            |
| $I_{IN-DIS}$                   | Input current, disabled                                    | UVLO < 2.5 V or OVLO > 2.5 V   |      | 480 | 650  | $\mu\text{A}$ |
| POR <sub>IT</sub>              | Power-On reset threshold at VIN to trigger insertion timer | VIN increasing   |      | 7.6 | 8    | V             |
| POR <sub>EN</sub>              | Power-On reset threshold at VIN to enable all functions    | VIN increasing   |      | 8.4 | 9    | V             |
| POR <sub>EN-HYS</sub>          | POR <sub>EN</sub> hysteresis                               | VIN decreasing   |      | 90  |      | mV            |
| <b>OUT PIN</b>                 |  |  |      |     |      |               |
| $I_{OUT-EN}$                   | OUT bias current, enabled                                  | OUT = VIN, Normal operation  |      | 11  |      | $\mu\text{A}$ |
| $I_{OUT-DIS}$                  | OUT bias current, disabled <sup>(1)</sup>                  | Disabled, OUT = 0 V, SENSE = VIN   |      | 50  |      |               |
| <b>UVLO, OVLO PINS</b>         |  |  |      |     |      |               |
| UVLO <sub>TH</sub>             | UVLO threshold   |  | 2.45 | 2.5 | 2.55 | V             |
| UVLO <sub>HYS</sub>            | UVLO hysteresis current                                    | UVLO = 1 V   | 12   | 21  | 30   | $\mu\text{A}$ |
| UVLO <sub>DEL</sub>            | UVLO delay   | Delay to GATE high   |      | 55  |      | $\mu\text{s}$ |
|                                |  | Delay to GATE low  |      | 11  |      |               |
| UVLO <sub>BIAS</sub>           | UVLO bias current  | UVLO = 48 V  |      |     | 1    | $\mu\text{A}$ |
| OVLO <sub>TH</sub>             | OVLO threshold   |  | 2.4  | 2.5 | 2.6  | V             |
| OVLO <sub>HYS</sub>            | OVLO hysteresis current                                    | OVLO = 2.6 V   | 12   | 21  | 30   | $\mu\text{A}$ |
| OVLO <sub>DEL</sub>            | OVLO delay   | Delay to GATE high   |      | 55  |      | $\mu\text{s}$ |
|                                |  | Delay to GATE low  |      | 11  |      |               |
| OVLO <sub>BIAS</sub>           | OVLO bias current  | OVLO = 2.4 V   |      |     | 1    | $\mu\text{A}$ |
| <b>POWER LIMIT (PWR PIN)</b>   |  |  |      |     |      |               |
| PWR <sub>LIM-1</sub>           | Power limit sense voltage (VIN-SENSE)                      | SENSE-OUT = 48 V, R <sub>PWR</sub> = 150 k $\Omega$                        | 19   | 25  | 31   | mV            |
| PWR <sub>LIM-2</sub>           |  | SENSE-OUT = 24 V, R <sub>PWR</sub> = 75 k $\Omega$                         |      | 25  |      | mV            |
| $I_{PWR}$                      | PWR pin current  | V <sub>PWR</sub> = 2.5 V   |      | 20  |      | $\mu\text{A}$ |
| <b>GATE CONTROL (GATE PIN)</b> |  |  |      |     |      |               |
| $I_{GATE}$                     | Source current   | Normal operation, GATE-OUT = 5 V   | 10   | 16  | 22   | $\mu\text{A}$ |
|                                | Sink current   | UVLO < 2.5 V   | 1.75 | 2   | 2.6  | mA            |
|                                |  | VIN to SENSE = 150 mV or VIN < POR <sub>IT</sub> , V <sub>GATE</sub> = 5 V | 45   | 110 | 175  | mA            |
| V <sub>GATE</sub>              | Gate output voltage in normal operation                    | GATE-OUT voltage   | 11.4 | 12  | 12.6 | V             |

(1) OUT bias current (disabled) due to leakage current through an internal 1-M $\Omega$  resistance from SENSE to VOUT.

## Electrical Characteristics (continued)

Minimum and maximum limits are specified through test, design, or statistical correlation at  $T_J = -40^{\circ}\text{C}$  to  $125^{\circ}\text{C}$ . Typical values represent the most likely parametric norm at  $T_J = 25^{\circ}\text{C}$  and are provided for reference purposes only.  $V_{IN} = 48\text{ V}$  (unless otherwise noted).

| PARAMETER                   |                                     | TEST CONDITIONS   | MIN   | TYP  | MAX   | UNIT          |
|-----------------------------|-------------------------------------|---|-------|------|-------|---------------|
| <b>CURRENT LIMIT</b>        |                                     |   |       |      |       |               |
| $V_{CL}$                    | Threshold voltage                   | VIN-SENSE voltage   | 48.5  | 55   | 61.5  | mV            |
| $t_{CL}$                    | Response time                       | VIN-SENSE stepped from 0 mV to 80 mV                                |       | 45   |       | $\mu\text{s}$ |
| $I_{SENSE}$                 | SENSE input current                 | Enabled, SENSE = OUT  |       | 23   |       | $\mu\text{A}$ |
|                             |                                     | Disabled, OUT = 0 V   |       | 60   |       |               |
| <b>CIRCUIT BREAKER</b>      |                                     |   |       |      |       |               |
| $V_{CB}$                    | Threshold voltage                   | VIN to SENSE  | 80    | 105  | 130   | mV            |
| $t_{CB}$                    | Response time                       | VIN to SENSE stepped from 0 mV to 150 mV, time to GATE low, no load |       | 0.44 | 1.2   | $\mu\text{s}$ |
| <b>TIMER (TIMER PIN)</b>    |                                     |   |       |      |       |               |
| $V_{TMRH}$                  | Upper threshold                     |   | 3.76  | 4    | 4.16  | V             |
| $V_{TMRL}$                  | Lower threshold                     | Restart cycles (LM5069-2)   | 1.187 | 1.25 | 1.313 | V             |
|                             |                                     | End of 8th cycle (LM5069-2)   |       | 0.3  |       | V             |
|                             |                                     | Re-enable Threshold (LM5069-1)                                      |       | 0.3  |       | V             |
| $I_{TIMER}$                 | Insertion time current              |   | 3     | 5.5  | 8     | $\mu\text{A}$ |
|                             | Sink current, end of insertion time | TIMER pin = 2 V   | 1     | 1.5  | 2     | mA            |
|                             | Fault detection current             |   | 51    | 85   | 120   | $\mu\text{A}$ |
|                             | Fault sink current                  |   | 1.25  | 2.5  | 3.75  | $\mu\text{A}$ |
| $DC_{FAULT}$                | Fault restart duty cycle            | LM5069-2 only   |       | 0.5% |       |               |
| $t_{FAULT}$                 | Fault to GATE low delay             | TIMER pin reaches 4 V   |       | 12   |       | $\mu\text{s}$ |
| <b>POWER GOOD (PGD PIN)</b> |                                     |   |       |      |       |               |
| $PGD_{TH}$                  | Threshold measured at SENSE-OUT     | Decreasing  | 0.67  | 1.25 | 1.85  | V             |
|                             |                                     | Increasing, relative to decreasing threshold                        | 0.95  | 1.25 | 1.55  |               |
| $PGD_{VOL}$                 | Output low voltage                  | $I_{SINK} = 2\text{ mA}$  |       | 60   | 150   | mV            |
| $PGD_{IOH}$                 | Off leakage current                 | $V_{PGD} = 80\text{ V}$   |       |      | 5     | $\mu\text{A}$ |

## 7.6 Typical Characteristics

$T_J = 25^\circ\text{C}$  and  $V_{IN} = 48\text{ V}$  (unless otherwise noted)

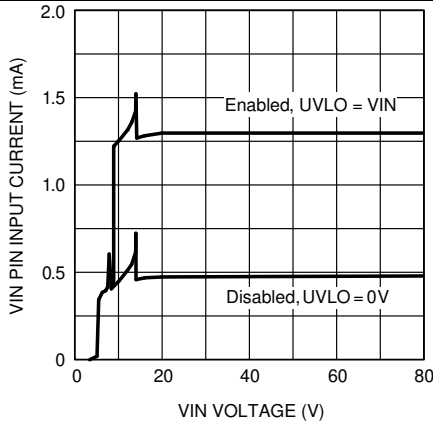

Figure 1. VIN Pin Input Current vs VIN

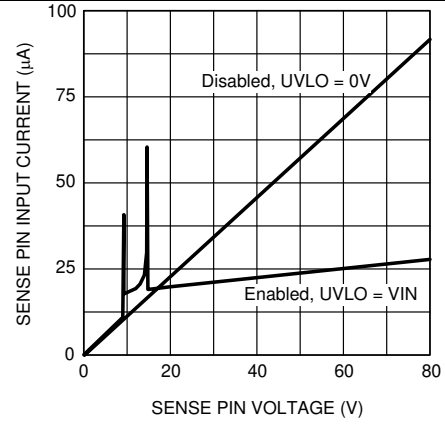

Figure 2. SENSE Pin Input Current

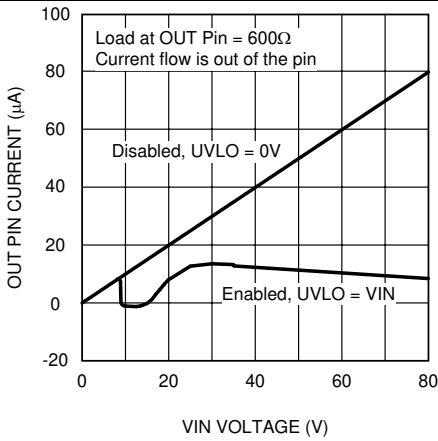

Figure 3. OUT Pin Current

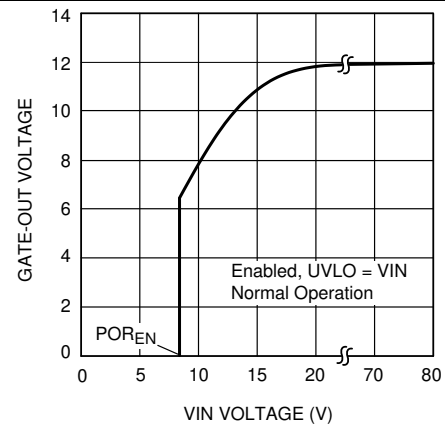

Figure 4. GATE Pin Voltage vs  $V_{IN}$

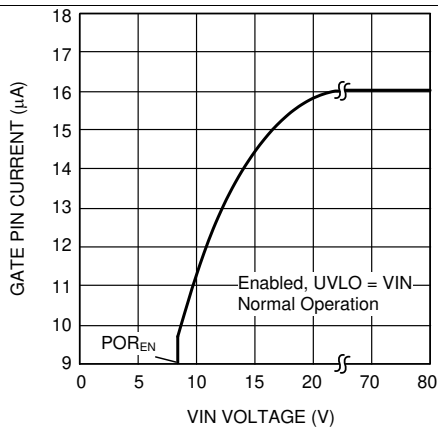

Figure 5. GATE Pin Source Current vs  $V_{IN}$

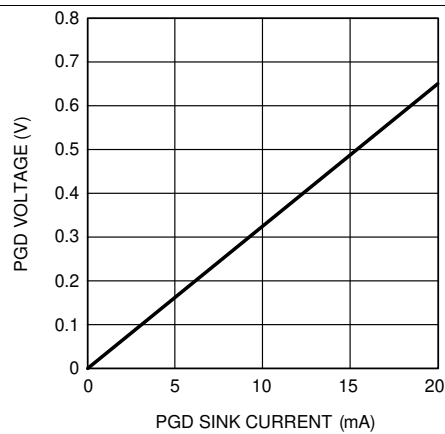

Figure 6. PGD Pin Low Voltage vs Sink Current

Typical Characteristics (continued)

$T_J = 25^\circ\text{C}$  and  $V_{IN} = 48\text{ V}$  (unless otherwise noted)

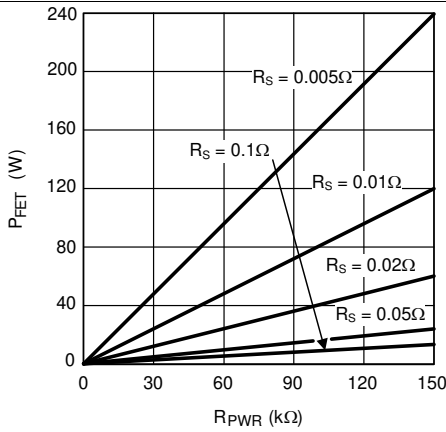

Figure 7. MOSFET Power Dissipation Limit vs  $R_{PWR}$  and  $R_S$

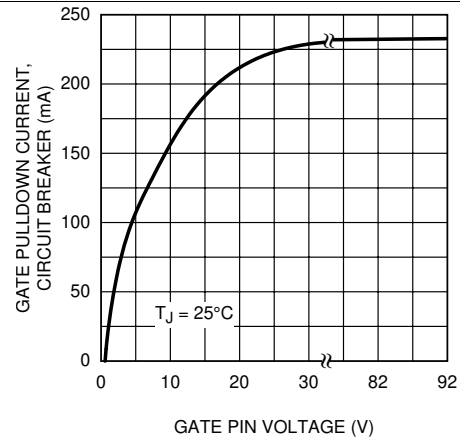

Figure 8. GATE Pulldown Current, Circuit Breaker vs GATE Voltage

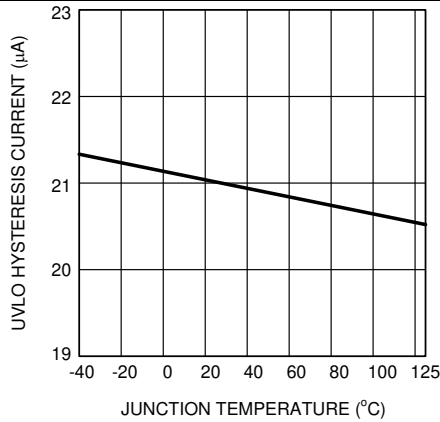

Figure 9. UVLO Hysteresis Current vs Temperature

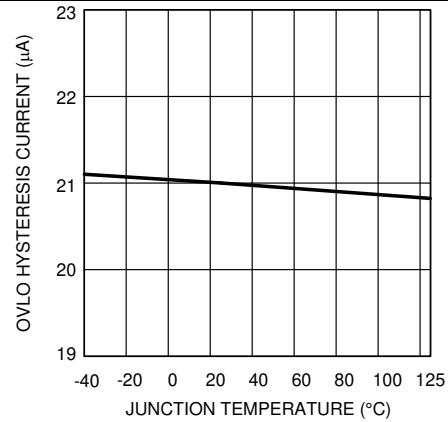

Figure 10. OVLO Hysteresis Current vs Temperature

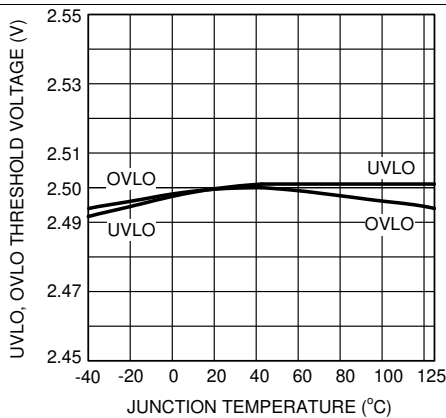

Figure 11. UVLO, OVLO Threshold vs Temperature

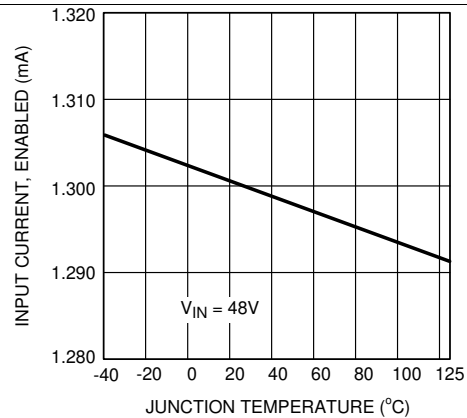

Figure 12. Input Current, Enabled vs Temperature



Typical Characteristics (continued)

$T_J = 25^\circ\text{C}$  and  $V_{IN} = 48\text{ V}$  (unless otherwise noted)

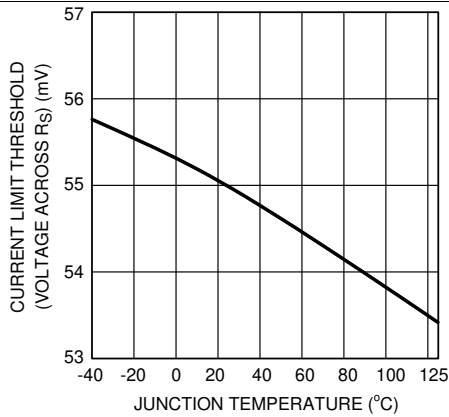

Figure 13. Current Limit Threshold vs Temperature

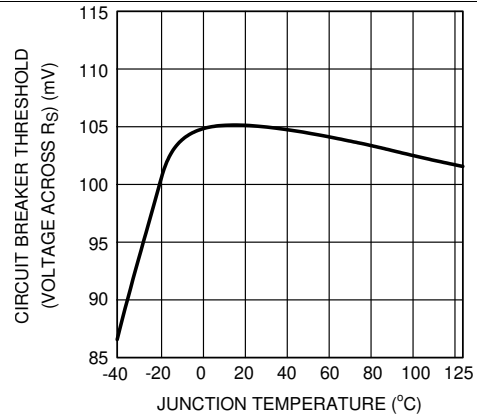

Figure 14. Circuit Breaker Threshold vs Temperature

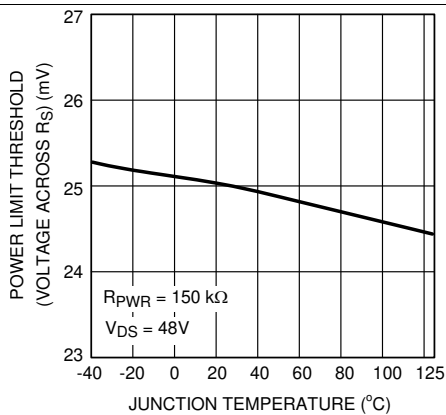

Figure 15. Power Limit Threshold vs Temperature

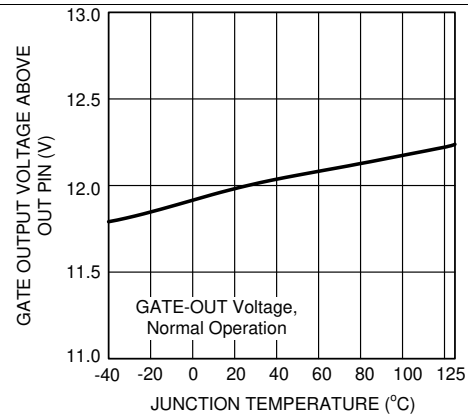

Figure 16. GATE Output Voltage vs Temperature

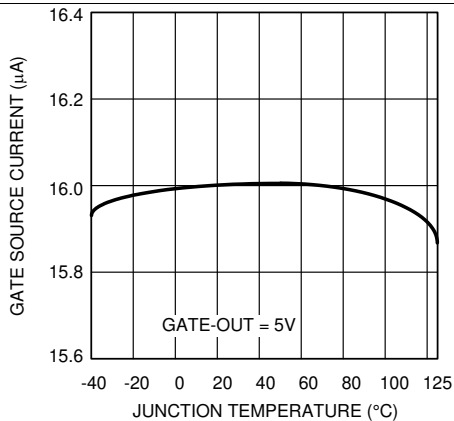

Figure 17. GATE Source Current vs Temperature

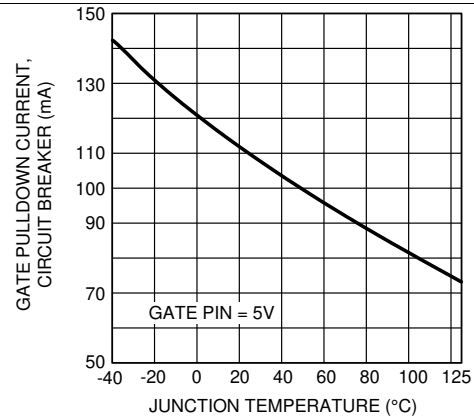
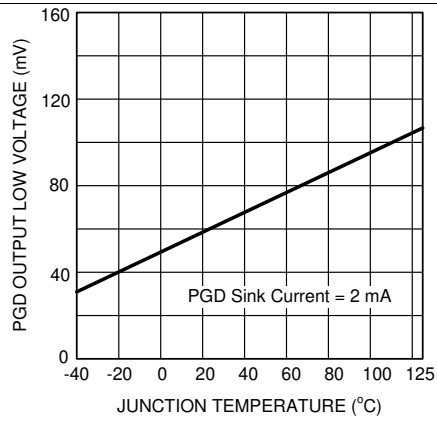

Figure 18. GATE Pulldown Current, Circuit Breaker vs Temperature

**Typical Characteristics (continued)**

$T_J = 25^\circ\text{C}$  and  $V_{IN} = 48\text{ V}$  (unless otherwise noted)



**Figure 19. PGD Low Voltage vs Temperature**

## 8 Detailed Description

### 8.1 Overview

The inline protection functionality of the LM5069 is designed to control the in-rush current to the load upon insertion of a circuit card into a live backplane or other hot power source, thereby limiting the voltage sag on the backplane's supply voltage and the  $dV/dt$  of the voltage applied to the load. Effects on other circuits in the system are minimized, preventing possible unintended resets. A controlled shutdown when the circuit card is removed can also be implemented using the LM5069.

In addition to a programmable current limit, the LM5069 monitors and limits the maximum power dissipation in the series pass device to maintain operation within the device Safe Operating Area (SOA). Either current limiting or power limiting for an extended period of time results in the shutdown of the series pass device. In this event, the LM5069-1 latches off while the LM5069-2 retries an infinite number of times to recover after the fault is removed. The circuit breaker function quickly switches off the series pass device upon detection of a severe overcurrent condition. Programmable undervoltage lockout (UVLO) and overvoltage lockout (OVLO) circuits shut down the LM5069 when the system input voltage is outside the desired operating range.

### 8.2 Functional Block Diagram

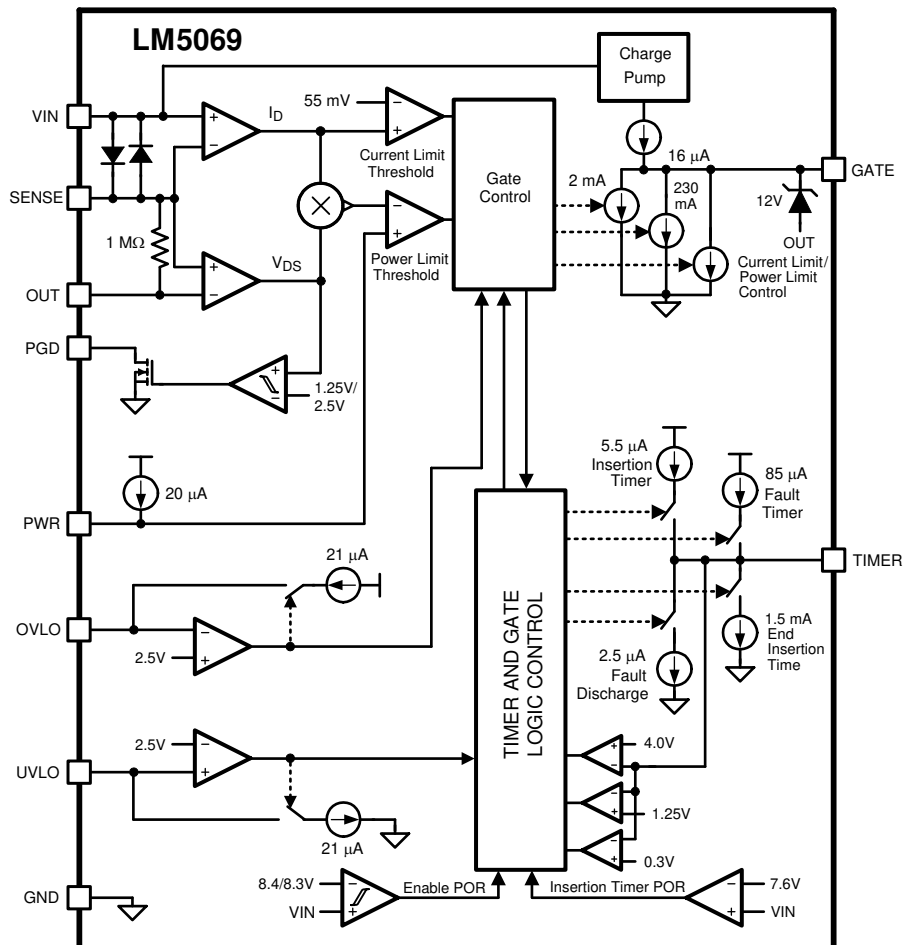

## 8.3 Feature Description

### 8.3.1 Current Limit

The current limit threshold is reached when the voltage across the sense resistor  $R_S$  (VIN to SENSE) reaches 55 mV. In the current limiting condition, the GATE voltage is controlled to limit the current in MOSFET Q1. While the current limit circuit is active, the fault timer is active as described in [Fault Timer and Restart](#). If the load current falls below the current limit threshold before the end of the fault timeout period, the LM5069 resumes normal operation. For proper operation, the  $R_S$  resistor value must be no larger than 100 m $\Omega$ .

### 8.3.2 Circuit Breaker

If the load current increases rapidly (for example, the load is short-circuited) the current in the sense resistor ( $R_S$ ) may exceed the current limit threshold before the current limit control loop is able to respond. If the current exceeds twice the current limit threshold (105 mV/ $R_S$ ), Q1 is quickly switched off by the 230-mA pulldown current at the GATE pin, and a fault timeout period begins. When the voltage across  $R_S$  falls below 105 mV the 230-mA pulldown current at the GATE pin is switched off, and the gate voltage of Q1 is then determined by the current limit or the power limit functions. If the TIMER pin reaches 4 V before the current limiting or power limiting condition ceases, Q1 is switched off by the 2-mA pulldown current at the GATE pin as described in [Fault Timer and Restart](#).

### 8.3.3 Power Limit

An important feature of the LM5069 is the MOSFET power limiting. The Power Limit function can be used to maintain the maximum power dissipation of MOSFET Q1 within the device SOA rating. The LM5069 determines the power dissipation in Q1 by monitoring its drain-source voltage (SENSE to OUT), and the drain current through the sense resistor (VIN to SENSE). The product of the current and voltage is compared to the power limit threshold programmed by the resistor at the PWR pin. If the power dissipation reaches the limiting threshold, the GATE voltage is modulated to reduce the current in Q1. While the power limiting circuit is active, the fault timer is active as described in [Fault Timer and Restart](#).

### 8.3.4 Undervoltage Lockout (UVLO)

The series pass MOSFET (Q1) is enabled when the input supply voltage ( $V_{SYS}$ ) is within the operating range defined by the programmable undervoltage lockout (UVLO) and overvoltage lockout (OVLO) levels. Typically the UVLO level at  $V_{SYS}$  is set with a resistor divider (R1-R3) as shown in [Figure 30](#). When  $V_{SYS}$  is below the UVLO level, the internal 21- $\mu$ A current source at UVLO is enabled, the current source at OVLO is off, and Q1 is held off by the 2-mA pulldown current at the GATE pin. As  $V_{SYS}$  is increased, raising the voltage at UVLO above 2.5 V, the 21- $\mu$ A current source at UVLO is switched off, increasing the voltage at UVLO, providing hysteresis for this threshold. With the UVLO pin above 2.5 V, Q1 is switched on by the 16- $\mu$ A current source at the GATE pin if the insertion time delay has expired ([Figure 22](#)). See [Application and Implementation](#) for a procedure to calculate the values of the threshold setting resistors (R1-R3). The minimum possible UVLO level at  $V_{SYS}$  can be set by connecting the UVLO pin to VIN. In this case Q1 is enabled when the VIN voltage reaches the  $POR_{EN}$  threshold.

### 8.3.5 Overvoltage Lockout (OVLO)

The series pass MOSFET (Q1) is enabled when the input supply voltage ( $V_{SYS}$ ) is within the operating range defined by the programmable undervoltage lockout (UVLO) and overvoltage lockout (OVLO) levels. If  $V_{SYS}$  raises the OVLO pin voltage above 2.5 V, Q1 is switched off by the 2-mA pulldown current at the GATE pin, denying power to the load. When the OVLO pin is above 2.5 V, the internal 21- $\mu$ A current source at OVLO is switched on, raising the voltage at OVLO to provide threshold hysteresis. When  $V_{SYS}$  is reduced below the OVLO level Q1 is enabled. See [Application and Implementation](#) for a procedure to calculate the threshold setting resistor values.

### 8.3.6 Power Good Pin

During turnon, the Power Good pin (PGD) is high until the voltage at VIN increases above  $\approx 5$  V. PGD then switches low, remaining low as the VIN voltage increases. When the voltage at OUT increases to within 1.25 V of the SENSE pin ( $V_{DS} < 1.25$  V), PGD switches high. PGD switches low if the  $V_{DS}$  of Q1 increases above 2.5 V. A pullup resistor is required at PGD as shown in [Figure 20](#). The pullup voltage ( $V_{PGD}$ ) can be as high as 80 V, with transient capability to 100 V, and can be higher or lower than the voltages at VIN and OUT.

## Feature Description (continued)

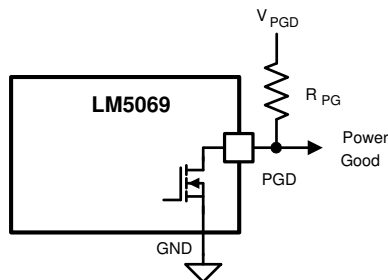

Copyright © 2016, Texas Instruments Incorporated

**Figure 20. Power Good Output**

If a delay is required at PGD, suggested circuits are shown in Figure 21. In Figure 21a, capacitor  $C_{PG}$  adds delay to the rising edge, but not to the falling edge. In Figure 21b, the rising edge is delayed by  $R_{PG1} + R_{PG2}$  and  $C_{PG}$ , while the falling edge is delayed a lesser amount by  $R_{PG2}$  and  $C_{PG}$ . Adding a diode across  $R_{PG2}$  (Figure 21c) allows for equal delays at the two edges, or a short delay at the rising edge and a long delay at the falling edge.

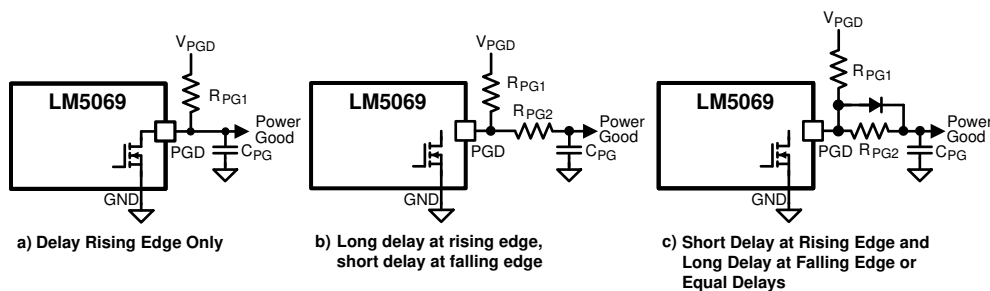

Copyright © 2016, Texas Instruments Incorporated

**Figure 21. Adding Delay to the Power Good Output Pin**

## 8.4 Device Functional Modes

The LM5069 hot swap controller has a power up sequence which can be broken down into 3x distinct sections: Insertion Time, In-Rush Limiting, and Normal Operation. Once the device reaches normal operation, the GATE and TIMER behavior depends on whether a fault condition is present or not on the output.

### 8.4.1 Power Up Sequence

The VIN operating range of the LM5069 is 9 V to 80 V, with a transient capability to 100 V. See [Functional Block Diagram](#) and [Figure 22](#), as the voltage at VIN initially increases, the external N-channel MOSFET (Q1) is held off by an internal 230-mA pulldown current at the GATE pin. The strong pulldown current at the GATE pin prevents an inadvertent turnon as the MOSFET's gate-to-drain (Miller) capacitance is charged. Additionally, the TIMER pin is initially held at ground. When the VIN voltage reaches the  $POR_{IT}$  threshold (7.6 V) the insertion time begins. During the insertion time, the capacitor at the TIMER pin ( $C_T$ ) is charged by a 5.5- $\mu$ A current source, and Q1 is held off by a 2-mA pulldown current at the GATE pin regardless of the VIN voltage. The insertion time delay allows ringing and transients at VIN to settle before Q1 can be enabled. The insertion time ends when the TIMER pin voltage reaches 4 V.  $C_T$  is then quickly discharged by an internal 1.5-mA pulldown current. After the insertion time, the LM5069 control circuitry is enabled when VIN reaches the  $POR_{EN}$  threshold (8.4 V). The GATE pin then switches on Q1 when  $V_{SYS}$  exceeds the UVLO threshold (UVLO pin >2.5 V). If  $V_{SYS}$  is above the UVLO threshold at the end of the insertion time, Q1 switches on at that time. The GATE pin charge pump sources 16  $\mu$ A to charge Q1's gate capacitance. The maximum gate-to-source voltage of Q1 is limited by an internal 12-V Zener diode.

### Device Functional Modes (continued)

As the voltage at the OUT pin increases, the LM5069 monitors the drain current and power dissipation of MOSFET Q1. In-rush current limiting and/or power limiting circuits actively control the current delivered to the load. During the in-rush limiting interval ( $t_2$  in Figure 22) an internal 85- $\mu\text{A}$  fault timer current source charges  $C_T$ . If Q1's power dissipation and the input current reduce below their respective limiting thresholds before the TIMER pin reaches 4 V, the 85- $\mu\text{A}$  current source is switched off, and  $C_T$  is discharged by the internal 2.5- $\mu\text{A}$  current sink ( $t_3$  in Figure 22). The in-rush limiting interval is complete when the voltage at the OUT pin increases to within 1.25 V of the input voltage ( $V_{\text{SYS}}$ ), and the PGD pin switches high.

If the TIMER pin voltage reaches 4 V before in-rush current limiting or power limiting ceases (during  $t_2$ ), a fault is declared and Q1 is turned off. See *Fault Timer and Restart* for a complete description of the fault mode.

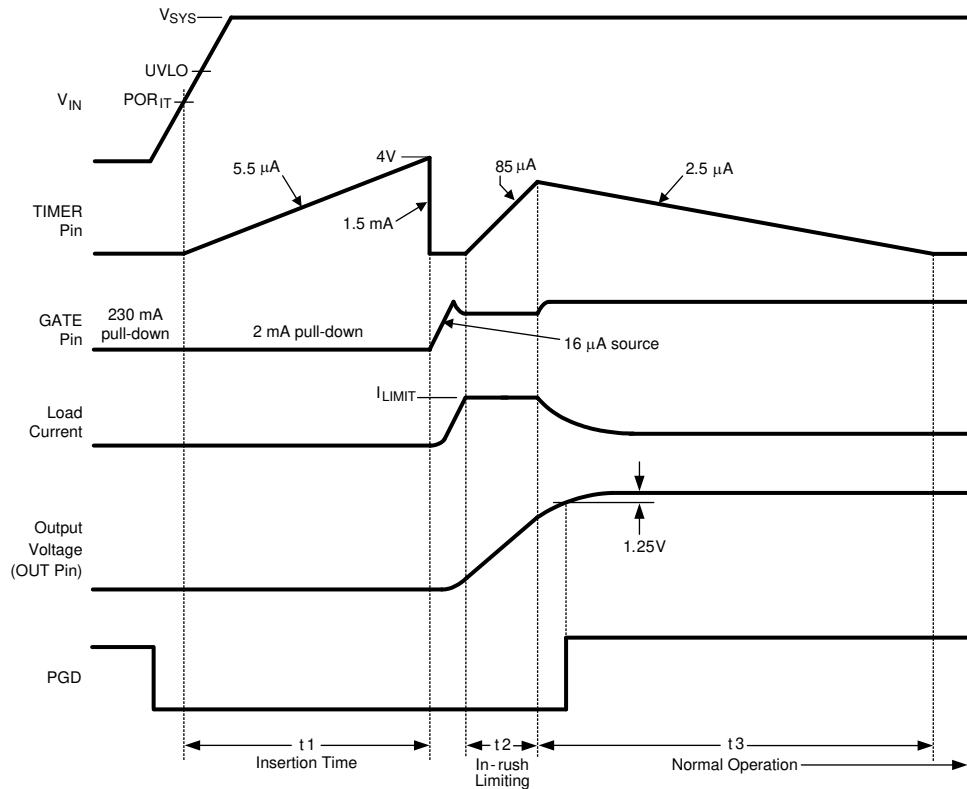

Figure 22. Power-Up Sequence (Current Limit Only)

#### 8.4.2 Gate Control

A charge pump provides internal bias voltage above the output voltage (OUT pin) to enhance the N-Channel MOSFET's gate. The gate-to-source voltage is limited by an internal 12-V Zener diode. During normal operating conditions ( $t_3$  in Figure 22) the gate of Q1 is held charged by an internal 16- $\mu\text{A}$  current source to approximately 12 V above OUT. If the maximum  $V_{\text{GS}}$  rating of Q1 is less than 12 V, an external Zener diode of lower voltage must be added between the GATE and OUT pins. The external Zener diode must have a forward current rating of at least 250 mA.

When the system voltage is initially applied, the GATE pin is held low by a 230-mA pulldown current. This helps prevent an inadvertent turnon of the MOSFET through its drain-gate capacitance as the applied system voltage increases.

During the insertion time ( $t_1$  in Figure 22) the GATE pin is held low by a 2-mA pulldown current. This maintains Q1 in the off-state until the end of  $t_1$ , regardless of the voltage at  $V_{\text{IN}}$  or UVLO.

Following the insertion time, during  $t_2$  in Figure 22, the gate voltage of Q1 is modulated to keep the current or power dissipation level from exceeding the programmed levels. While in the current or power limiting mode the TIMER pin capacitor is charging. If the current and power limiting cease before the TIMER pin reaches 4 V the TIMER pin capacitor then discharges, and the circuit enters normal operation.

## Device Functional Modes (continued)

If the in-rush limiting condition persists such that the TIMER pin reached 4 V during  $t_2$ , the GATE pin is then pulled low by the 2-mA pulldown current. The GATE pin is then held low until either a power-up sequence is initiated (LM5069-1), or until the end of the restart sequence (LM5069-2). See [Fault Timer and Restart](#).

If the system input voltage falls below the UVLO threshold, or rises above the OVLO threshold, the GATE pin is pulled low by the 2-mA pulldown current to switch off Q1.

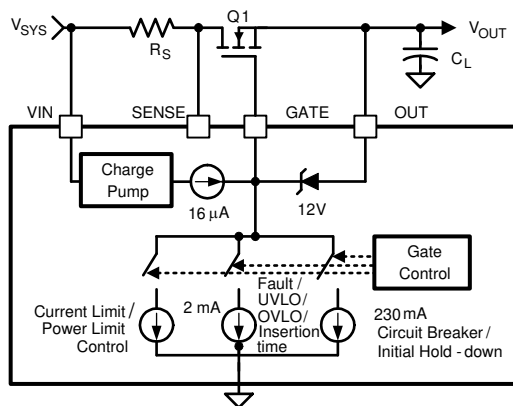
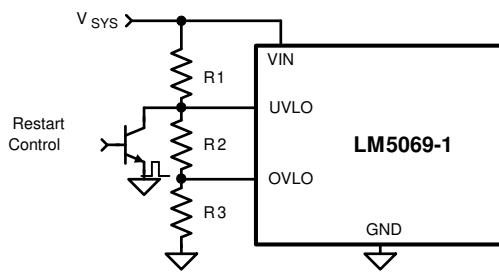

Figure 23. Gate Control

### 8.4.3 Fault Timer and Restart

When the current limit or power limit threshold is reached during turnon or as a result of a fault condition, the gate-to-source voltage of Q1 is modulated to regulate the load current and power dissipation. When either limiting function is activated, an 85- $\mu$ A fault timer current source charges the external capacitor ( $C_T$ ) at the TIMER pin as shown in [Figure 25](#) (fault timeout period). If the fault condition subsides during the fault timeout period before the TIMER pin reaches 4 V, the LM5069 returns to the normal operating mode and  $C_T$  is discharged by the 2.5- $\mu$ A current sink. If the TIMER pin reaches 4 V during the fault timeout period, Q1 is switched off by a 2-mA pulldown current at the GATE pin. The subsequent restart procedure then depends on which version of the LM5069 is in use.

The LM5069-1 latches the GATE pin low at the end of the fault timeout period.  $C_T$  is then discharged to ground by the 2.5- $\mu$ A fault current sink. The GATE pin is held low by the 2-mA pulldown current until a power-up sequence is externally initiated by cycling the input voltage ( $V_{SYS}$ ), or momentarily pulling the UVLO pin below 2.5 V with an open-collector or open-drain device as shown in [Figure 24](#). The voltage at the TIMER pin must be  $<0.3$  V for the restart procedure to be effective.



Copyright © 2016, Texas Instruments Incorporated

Figure 24. Latched Fault Restart Control

The LM5069-2 provides an automatic restart sequence which consists of the TIMER pin cycling between 4 V and 1.25 V seven times after the fault timeout period, as shown in [Figure 25](#). The period of each cycle is determined by the 85- $\mu$ A charging current, and the 2.5- $\mu$ A discharge current, and the value of the capacitor  $C_T$ . When the TIMER pin reaches 0.3 V during the eighth high-to-low ramp, the 16- $\mu$ A current source at the GATE pin turns on Q1. If the fault condition is still present, the fault timeout period and the restart cycle repeat.

Device Functional Modes (continued)

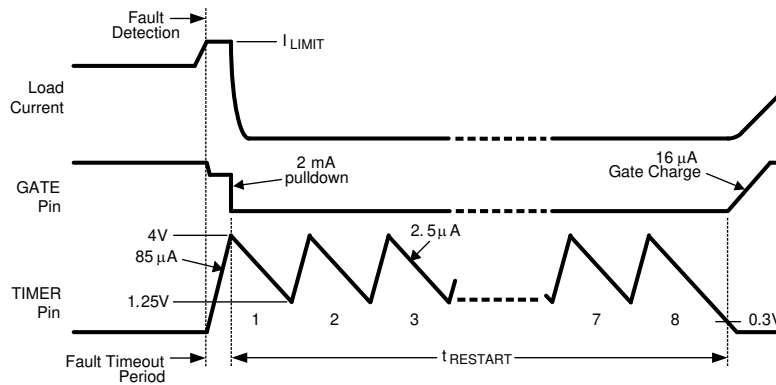
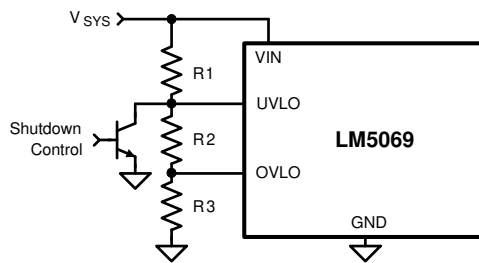

Figure 25. Restart Sequence (LM5069-2)

8.4.4 Shutdown Control

The load current can be remotely switched off by taking the UVLO pin below its 2.5-V threshold with an open collector or open-drain device, as shown in Figure 26. Upon releasing the UVLO pin the LM5069 switches on the load current with in-rush current and power limiting.



Copyright © 2016, Texas Instruments Incorporated

Figure 26. Shutdown Control



## 9 Application and Implementation

### NOTE

Information in the following applications sections is not part of the TI component specification, and TI does not warrant its accuracy or completeness. TI's customers are responsible for determining suitability of components for their purposes. Customers should validate and test their design implementation to confirm system functionality.

### 9.1 Application Information

The LM5069 is a hot swap controller which is used to manage inrush current and protect in case of faults. When designing a hot swap, three key scenarios must be considered:

- Start-up
- Output of a hot swap is shorted to ground when the hot swap is on. This is often referred to as a hot-short.
- Powering up a board when the output and ground are shorted. This is usually called a start-into-short.

All of these scenarios place a lot of stress on the hot swap MOSFET and thus special care is required when designing the hot swap circuit to keep the MOSFET within its SOA (Safe Operating Area). Detailed design examples are provided in the following sections. Solving all of the equations by hand is cumbersome and can result in errors. Instead, TI recommends using the LM5069 Design Calculator provided on the product page.

### 9.2 Typical Application

#### 9.2.1 48-V, 10-A Hot Swap Design

This section describes the design procedure for a 48-V, 10-A hot swap design.

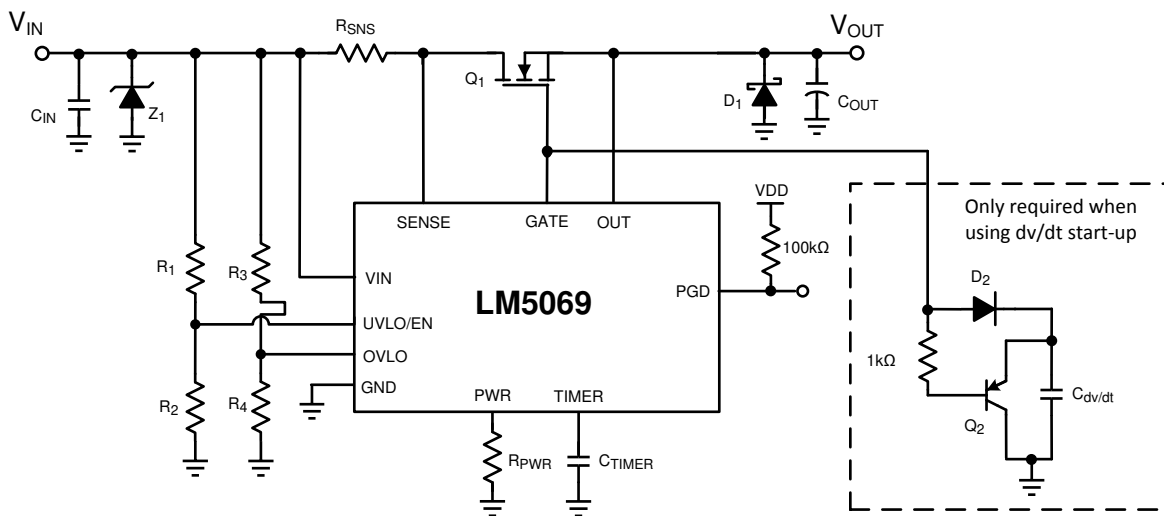

Copyright © 2016, Texas Instruments Incorporated

Figure 27. Typical Application Schematic

#### 9.2.1.1 Design Requirements

Table 1 summarizes the design parameters that must be known before designing a hot swap circuit. When charging the output capacitor through the hot swap MOSFET, the FET's total energy dissipation equals the total energy stored in the output capacitor ( $\frac{1}{2}CV^2$ ). Thus, both the input voltage and output capacitance determine the stress experienced by the MOSFET. The maximum load current drives the current limit and sense resistor selection. In addition, the maximum load current, maximum ambient temperature, and the thermal properties of

## Typical Application (continued)

the PCB ( $R_{\theta CA}$ ) drive the selection of the MOSFET  $R_{DS(ON)}$  and the number of MOSFETs used.  $R_{\theta CA}$  is a strong function of the layout and the amount of copper that is connected to the drain of the MOSFET. Note that the drain is not electrically connected to the ground plane and thus the ground plane cannot be used to help with heat dissipation. For this design example  $R_{\theta CA} = 30^{\circ}\text{C/W}$  is used, which is similar to the LM5069 EVM. It's a good practice to measure the  $R_{\theta CA}$  of a given design after the physical PCBs are available.

Finally, it's important to understand what test conditions the hot swap must pass. In general, a hot swap is designed to pass both a *Hot-Short* and a *Start into a Short*. Also, TI recommends keeping the load OFF until the hot swap is fully powered up. Starting the load early causes unnecessary stress on the MOSFET and could lead to MOSFET failures or a failure to start-up.

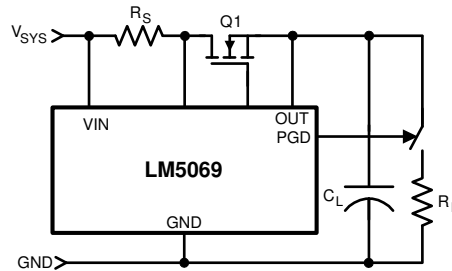

Copyright © 2016, Texas Instruments Incorporated

**Figure 28. No Load Current During Turnon**

**Table 1. Design Parameters**

| PARAMETER                                   | VALUE             |
|---|-------------------|
| Input voltage range                         | 18 to 30 V        |
| Maximum load current                        | 10 A              |
| Lower UVLO threshold                        | 17 V              |
| Upper UVLO threshold                        | 18 V              |
| Lower OVLO threshold                        | 30 V              |
| Upper OVLO threshold                        | 31 V              |
| Maximum output capacitance of the hot swap  | 330 $\mu\text{F}$ |
| Maximum ambient temperature                 | 55°C              |
| MOSFET $R_{\theta CA}$ (function of layout) | 30°C/W            |
| Pass <i>Hot-short</i> on output?            | Yes               |
| Pass a <i>Start into short</i> ?            | Yes               |
| Is the load off until PG asserted?          | Yes               |
| Can a hot board be plugged back in?         | No                |

### 9.2.1.2 Detailed Design Procedure

#### 9.2.1.2.1 Select $R_{SNS}$ and CL setting

The LM5069 monitors the current in the external MOSFET (Q1) by measuring the voltage across the sense resistor ( $R_S$ ), connected from VIN to SENSE. When the voltage difference across the VIN and SENSE pins ( $V_{CL}$ ) is greater than 55 mV (typical), the LM5069 begins modulating the MOSFET gate. Size  $R_{SNS}$  for maximum or minimum  $V_{CL}$  for applications that require ensured shutoff or ensured conduction.  $R_{SNS}$  is sized to exhibit minimum  $V_{CL}$  across  $R_{SNS}$  at maximum load current in [Equation 1](#).

$$R_{SNS} = \frac{V_{CL,MIN}}{I_{LIM}} = \frac{48.5\text{mV}}{10\text{A}} = 0.00485\Omega \quad (1)$$

Typically sense resistors are only available in discrete value. We choose the next smallest discrete value, 4 mΩ. If a precise current limit is desired, a sense resistor along with a resistor divider can be used as shown in Figure 29.

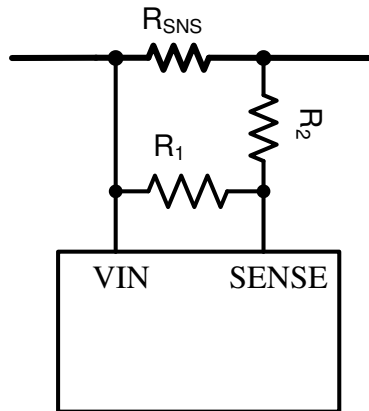

Figure 29. SENSE Resistor Divider

If using a resistor divider, then the next larger available sense resistor must be chosen (5 mΩ in this example). The ratio of R1 and R2 can then be calculated with Equation 2.

$$\frac{R_1}{R_2} = \frac{R_{SNS,CLC}}{R_{SNS} - R_{SNS,CLC}} = \frac{4.8 \text{ m}\Omega}{5 \text{ m}\Omega - 4.8 \text{ m}\Omega} = 24 \quad (2)$$

Note that the SENSE pin pulls 23 μA of current, which creates an offset across R2. TI recommends keeping R2 below 10 Ω to reduce the offset that this introduces. In addition, the 1% resistors add to the current monitoring error. Finally, if the resistor divider approach is used, compute the effective sense resistance ( $R_{SNS, EFF}$ ) using Equation 3 and use that in all equations instead of  $R_{SNS}$ .

$$R_{SNS, EFF} = \frac{R_{SNS} \times R_1}{R_1 + R_2} \quad (3)$$

Note that for many applications, a precise current limit may not be required. In that case, it's simpler to pick the next smaller available sense resistor.

#### 9.2.1.2.2 Selecting the Hot Swap FET(s)

It is critical to select the correct MOSFET for a hot swap design. The device must meet the following requirements:

- The  $V_{DS}$  rating must be sufficient to handle the maximum system voltage along with any ringing caused by transients.
- The SOA of the FET must be sufficient to handle all usage cases: start-up, hot-short, start into short.
- $R_{DS(ON)}$  must be sufficiently low to maintain the junction and case temperature below the maximum rating of the FET. In fact, TI recommends keeping the steady state FET temperature below 125°C to allow margin to handle transients.
- Maximum continuous current rating must be above the maximum load current and the pulsed drain current must be greater than the current threshold of the circuit breaker. Most MOSFETs that pass the first three requirements also pass these two.

For this design the SUM40N15-38 was selected. After selecting the MOSFET, the maximum steady state case temperature can be computed as Equation 4.

$$T_{C, MAX} = T_{A, MAX} + R_{\theta CA} \times I_{LOAD, MAX}^2 \times R_{DS(ON), MAX} (T_J) \quad (4)$$

Note that the  $R_{\text{DSON}}$  is a strong function of junction temperature, which for most MOSFETs is close to the case temperature. A few iterations of the above equations may be necessary to converge on the final  $R_{\text{DSON}}$  and  $T_{\text{C,MAX}}$  value. According to the CSD19536KTT datasheet, its  $R_{\text{DSON}}$  is approximately 1.2x at 65°C. Equation 5 uses this  $R_{\text{DSON}}$  value to compute the  $T_{\text{C,MAX}}$ .

$$T_{\text{C,MAX}} = 55^{\circ}\text{C} + 30^{\circ}\frac{\text{C}}{\text{W}} \times (10\text{ A})^2 \times (1.2 \times 2.4\text{ m}\Omega) = 63.64^{\circ}\text{C} \quad (5)$$

This maximum steady state case temperature does not indicate that a second MOSFET may be required to reduce and distribute power dissipation during normal operation.

As an aside, when using parallel MOSFETs, the maximum steady state case temperature can be computed in Equation 6.

$$T_{\text{C,MAX}} = T_{\text{A,MAX}} + R_{\theta\text{CA}} \times \left( \frac{I_{\text{LOAD,MAX}}}{\text{\# of MOSFETs}} \right)^2 \times R_{\text{DSON}} (T_{\text{J}}) \quad (6)$$

Iterate until the computed  $T_{\text{C,MAX}}$  is using two parallel MOSFETs is less than to the junction temperature assumed for  $R_{\text{DSON}}$ . Then, no further iterations are necessary.

### 9.2.1.2.3 Select Power Limit

In general, a lower-power limit setting is preferred to reduce the stress on the MOSFET. However, when the LM5069 is set to a very low power limit setting, it has to regulate the FET current and hence the voltage across the sense resistor ( $V_{\text{SNS}}$ ) to a very low value.  $V_{\text{SNS}}$  can be computed as shown in Equation 7.

$$V_{\text{SNS}} = \frac{P_{\text{LIM}} \times R_{\text{SNS}}}{V_{\text{DS}}} \quad (7)$$

To avoid significant degradation of the power limiting accuracy, a  $V_{\text{SNS}}$  of less than 5 mV is not recommended. Based on this requirement the minimum allowed power limit can be computed in Equation 8.

$$P_{\text{LIM,MIN}} = \frac{V_{\text{SNS,MIN}} \times V_{\text{IN,MAX}}}{R_{\text{SNS}}} = \frac{5\text{ mV} \times 30\text{ V}}{4\text{ m}\Omega} = 37.5\text{ W} \quad (8)$$

To avoid significant degradation of the power limiting accuracy a  $V_{\text{SNS}}$  of less than 5 mV is not recommended. Based on this requirement, the minimum allowed power limit can be computed with Equation 9.

$$R_{\text{PWR}} = 1.30 \times 10^5 \times R_{\text{SNS}} \left( P_{\text{LIM}} - 1.18\text{ mV} \times \frac{V_{\text{DS}}}{R_{\text{SNS}}} \right) \quad (9)$$

Note that the minimum  $R_{\text{PWR}}$  would occur when  $V_{\text{DS}} = V_{\text{IN,MAX}}$ . We can then compute the minimum  $R_{\text{PWR}}$  with Equation 10.

$$R_{\text{PWR}} = 1.30 \times 10^5 \times 4\text{ m}\Omega \left( 37.5\text{ W} - 1.18\text{ mV} \times \frac{30\text{ V}}{4\text{ m}\Omega} \right) = 14.9\text{ k}\Omega \quad (10)$$

To obtain the smallest accurate power limit, the next largest available resistor must be selected. In this case a 15.8-k $\Omega$  resistor was chosen, which sets a 39.23-W power limit.

### 9.2.1.2.4 Set Fault Timer

The fault timer runs when the hot swap is in power limit or current limit, which is the case during start-up. Thus the timer has to be sized large enough to prevent a time-out during start-up. If the part starts directly into current limit ( $I_{\text{LIM}} \times V_{\text{DS}} < P_{\text{LIM}}$ ) the maximum start time can be computed with Equation 11.

$$t_{\text{start,max}} = \frac{C_{\text{OUT}} \times V_{\text{IN,MAX}}}{I_{\text{LIM}}} \quad (11)$$

For most designs (including this example),  $I_{LIM} \times V_{DS} > P_{LIM}$ , so the hot swap starts in power limit and transition into current limit. In that case, the estimated start time can be computed with [Equation 12](#).

$$t_{start} = \frac{C_{OUT}}{2} \times \left[ \frac{V_{IN,MAX}^2}{P_{LIM}} + \frac{P_{LIM}}{I_{LIM}^2} \right] = \frac{330\mu F}{2} \times \left[ \frac{(30V)^2}{39.23W} + \frac{39.23W}{(10A)^2} \right] = 3.85ms \quad (12)$$

Note that the above start-time assumes constant, typical current limit and power limit values. The actual startup time is slightly longer, as the power limit is a function of  $V_{ds}$  and decreases as the output voltage increases. To ensure that the timer never times out during start-up, TI recommends setting the minimum fault time ( $t_{flt}$ ) to be greater than the start time ( $t_{start}$ ) by adding an additional margin of 50% of the fault time. This accounts for the variation in power limit, timer current, and timer capacitance. Thus  $C_{TIMER}$  can be computed with [Equation 13](#).

$$C_{TIMER} = \frac{t_{flt} \times i_{timer(typ)}}{V_{timer(typ)}} \times 1.5 = \frac{3.85ms \times 85\mu A}{4V} \times 1.5 = 123nF \quad (13)$$

The next largest available  $C_{TIMER}$  is chosen as 150 nf. Once the  $C_{TIMER}$  is chosen the actual programmed fault time can be computed with [Equation 14](#).

$$t_{flt} = \frac{C_{TIMER} \times V_{timer,typ}}{i_{timer,typ}} = \frac{150nF \times 4V}{85\mu A} = 7.06ms \quad (14)$$

This is the typical time that the LM5069 shuts off the CSD19536KTT MOSFET.

#### 9.2.1.2.5 Check MOSFET SOA

Once the power limit and fault timer are chosen, it's critical to check that the FET stays within its SOA during all test conditions. During a *Hot-Short*, the circuit breaker trips and the LM5069 restarts into power limit until the timer runs out. In the worst case, the MOSFET's  $V_{DS}$  equals  $V_{IN,MAX}$ ,  $I_{DS}$  equals  $P_{LIM} / V_{IN,MAX}$  and the stress event lasts for  $t_{flt}$ . For this design example, the MOSFET has 30 V, 1.25 A across it for 7.06 ms.

Based on the SOA of the CSD19536KTT, it can handle 30 V, 9 A for 10 ms and it can handle 30 V, 20 A for 1 ms. The SOA for 7.06 ms can be extrapolated by approximating SOA versus time as a power function as shown [Equation 15](#) through [Equation 18](#).

$$I_{SOA}(t) = a \times t^m \quad (15)$$

$$m = \frac{\ln \frac{I_{SOA}(t_1)}{I_{SOA}(t_2)}}{\ln \left( \frac{t_1}{t_2} \right)} = \frac{\ln \left( \frac{20A}{9A} \right)}{\ln \left( \frac{1ms}{10ms} \right)} = -0.346 \quad (16)$$

$$a = \frac{I_{SOA}(t_1)}{t_1^m} = \frac{20A}{(1ms)^{-0.346}} = 20A \times (1ms)^{0.346} \quad (17)$$

$$I_{SOA}(7.06ms) = 20A \times (1ms)^{0.346} \times (7.06ms)^{-0.346} = 10.17A \quad (18)$$

Note that the SOA of a MOSFET is specified at a case temperature of 25°C, while the case temperature can be much hotter during a hot-short. The SOA must be derated based on  $T_{C,MAX}$  using [Equation 19](#).

$$I_{SOA}(7.06ms, T_{C,MAX}) = I_{SOA}(7.06ms, 25^\circ C) \times \frac{T_{J,ABSMAX} - T_{C,MAX}}{T_{J,ABSMAX} - 25^\circ C} \quad (19)$$

$$= 10.17A \times \frac{175^\circ C - 63.6^\circ C}{175^\circ C - 25^\circ C} = 7.55A \quad (20)$$

Based on this calculation the MOSFET can handle 7.55 A, 30 V for 7.06 ms at elevated case temperature, and is required to handle 1.25 A during a hot-short. This means the MOSFET is not at risk of getting damaged during a hot-short. In general, TI recommends for the MOSFET to be able to handle a minimum of 1.3x more power than what is required during a hot-short to provide margin to cover the variance of the power limit and fault time.

### 9.2.1.2.6 Set Undervoltage and Overvoltage Threshold

By programming the UVLO and OVLO thresholds the LM5069 enables the series pass device (Q1) when the input supply voltage ( $V_{SYS}$ ) is within the desired operational range. If  $V_{SYS}$  is below the UVLO threshold, or above the OVLO threshold, Q1 is switched off, denying power to the load. Hysteresis is provided for each threshold.

#### 9.2.1.2.6.1 Option A

The configuration shown in [Figure 30](#) requires three resistors (R1-R3) to set the thresholds.

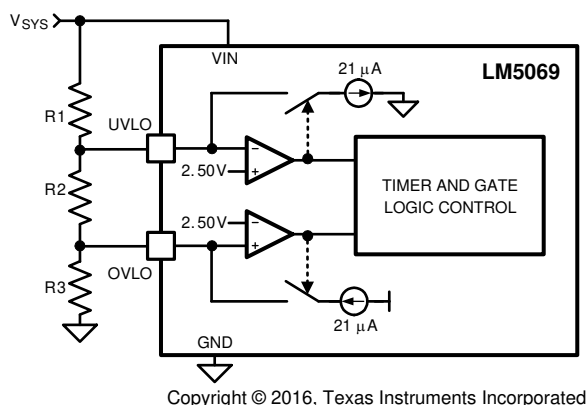

**Figure 30. UVLO and OVLO Thresholds Set By R1-R3**

The procedure to calculate the resistor values is as follows:

1. Choose the upper UVLO threshold ( $V_{UVH}$ ), and the lower UVLO threshold ( $V_{UVL}$ ).
2. Choose the upper OVLO threshold ( $V_{OVH}$ ).
3. The lower OVLO threshold ( $V_{OVL}$ ) cannot be chosen in advance in this case, but is determined after the values for R1-R3 are determined. If  $V_{OVL}$  must be accurately defined in addition to the other three thresholds, see Option B below.

The resistors are calculated with [Equation 21](#), [Equation 22](#), and [Equation 23](#).

$$R1 = \frac{V_{UVH} - V_{UVL}}{21 \mu A} = \frac{V_{UV(HYS)}}{21 \mu A} \quad (21)$$

$$R3 = \frac{2.5V \times R1 \times V_{UVL}}{V_{OVH} \times (V_{UVL} - 2.5V)} \quad (22)$$

$$R2 = \frac{2.5V \times R1}{V_{UVL} - 2.5V} - R3 \quad (23)$$

The lower OVLO threshold is calculated from [Equation 24](#).

$$V_{OVL} = \frac{[(R1 + R2) \times ((2.5V) - 21 \mu A)] + 2.5V}{R3} \quad (24)$$

As an example, assume the application requires the following thresholds:  $V_{UVH} = 36 V$ ,  $V_{UVL} = 32 V$ ,  $V_{OVH} = 60 V$ .

$$R1 = \frac{36V - 32V}{21 \mu A} = \frac{4V}{21 \mu A} = 190.5 k\Omega \quad (25)$$

$$R3 = \frac{2.5V \times 190.5 k\Omega \times 32V}{60V \times (32V - 2.5V)} = 8.61 k\Omega \quad (26)$$

$$R2 = \frac{2.5V \times 190.5 \text{ k}\Omega}{(32V - 2.5V)} - 8.61 \text{ k}\Omega = 7.53 \text{ k}\Omega \quad (27)$$

The lower OVLO threshold calculates to 55.8 V, and the OVLO hysteresis is 4.2 V. Note that the OVLO hysteresis is always slightly greater than the UVLO hysteresis in this configuration. When the R1-R3 resistor values are known, the threshold voltages and hysteresis are calculated from Equation 28 through Equation 33.

$$V_{UVH} = 2.5V + \left[ R1 \times (21 \mu\text{A} + \frac{2.5V}{(R2 + R3)}) \right] \quad (28)$$

$$V_{UVL} = \frac{2.5V \times (R1 + R2 + R3)}{R2 + R3} \quad (29)$$

$$V_{UV(HYS)} = R1 \times 21 \mu\text{A} \quad (30)$$

$$V_{OVH} = \frac{2.5V \times (R1 + R2 + R3)}{R3} \quad (31)$$

$$V_{OVL} = \left[ (R1 + R2) \times \frac{(2.5V)}{R3} - 21 \mu\text{A} \right] + 2.5V \quad (32)$$

$$V_{OV(HYS)} = (R1 + R2) \times 21 \mu\text{A} \quad (33)$$

**9.2.1.2.6.2 Option B**

If all four thresholds must be accurately defined, the configuration in Figure 31 can be used.

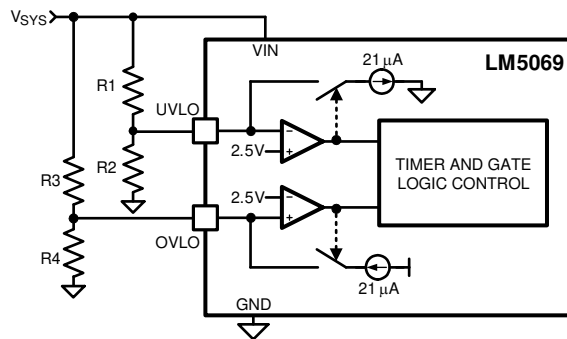

Copyright © 2016, Texas Instruments Incorporated

**Figure 31. Programming the Four Thresholds**

The four resistor values are calculated as follows:

1. Choose the upper UVLO threshold ( $V_{UVH}$ ) and lower UVLO threshold ( $V_{UVL}$ ) with Equation 34 and Equation 35.

$$R1 = \frac{V_{UVH} - V_{UVL}}{21 \mu\text{A}} = \frac{V_{UV(HYS)}}{21 \mu\text{A}} \quad (34)$$

$$R2 = \frac{2.5V \times R1}{(V_{UVL} - 2.5V)} \quad (35)$$

2. Choose the upper OVLO threshold ( $V_{OVH}$ ) and lower OVLO threshold ( $V_{OVL}$ ) with Equation 36 and Equation 37.

$$R3 = \frac{V_{OVH} - V_{OVL}}{21 \mu\text{A}} = \frac{V_{OV(HYS)}}{21 \mu\text{A}} \quad (36)$$

$$R4 = \frac{2.5V \times R3}{(V_{OVH} - 2.5V)} \quad (37)$$

As an example, assume the application requires the following thresholds:  $V_{UVH} = 22 \text{ V}$ ,  $V_{UVL} = 17 \text{ V}$ ,  $V_{OVH} = 60 \text{ V}$ , and  $V_{OVL} = 58 \text{ V}$ . Therefore  $V_{UV(HYS)} = 5 \text{ V}$ , and  $V_{OV(HYS)} = 2 \text{ V}$ . The resistor values are:

- $R1 = 238 \text{ k}\Omega$ ,  $R2 = 41 \text{ k}\Omega$
- $R3 = 95.2 \text{ k}\Omega$ ,  $R4 = 4.14 \text{ k}\Omega$

Where the R1-R4 resistor values are known, the threshold voltages and hysteresis are calculated from Equation 38 to Equation 43.

$$V_{UVH} = 2.5V + \left[ R1 \times \frac{(2.5V + 21 \mu A)}{R2} \right] \quad (38)$$

$$V_{UVL} = \frac{2.5V \times (R1 + R2)}{R2} \quad (39)$$

$$V_{UV(HYS)} = R1 \times 21 \mu A \quad (40)$$

$$V_{OVH} = \frac{2.5V \times (R3 + R4)}{R4} \quad (41)$$

$$V_{OVL} = 2.5V + \left[ R3 \times \frac{(2.5V - 21 \mu A)}{R4} \right] \quad (42)$$

$$V_{OV(HYS)} = R3 \times 21 \mu A \quad (43)$$

### 9.2.1.2.6.3 Option C

The minimum UVLO level is obtained by connecting the UVLO pin to VIN as shown in Figure 32. Q1 is switched on when the VIN voltage reaches the POR<sub>EN</sub> threshold ( $\approx 8.4$  V). An external transistor can be connected to UVLO to provide remote shutdown control, and to restart the LM5069-1 after a fault detection. The OVLO thresholds are set using R3, R4. Their values are calculated using the procedure in Option B.

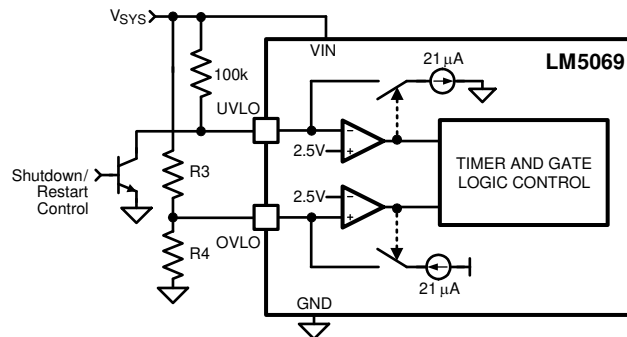

Copyright © 2016, Texas Instruments Incorporated

**Figure 32. UVLO = POR<sub>EN</sub> With Shutdown/Restart Control**

### 9.2.1.2.6.4 Option D

The OVLO function can be disabled by grounding the OVLO pin. The UVLO thresholds are set as described in Option B or Option C.

For this design example, option B is used and the following values are targeted:  $V_{UVH} = 10$  V,  $V_{UVL} = 9$  V,  $V_{OVH} = 15$  V,  $V_{OVL} = 14$  V. R1, R2, R3, and R4 are computed using Equation 44 through Equation 47.

$$R1 = \frac{V_{UVH} - V_{UVL}}{21 \mu A} = \frac{18V - 17V}{21 \mu A} = 47.62k \quad (44)$$

$$R2 = \frac{2.5V \times R1}{(V_{UVL} - 2.5V)} = \frac{2.5V \times 47.62k}{(17V - 2.5V)} = 8.21k \quad (45)$$

$$R3 = \frac{V_{OVH} - V_{OVL}}{21 \mu A} = \frac{31V - 30V}{21 \mu A} = 47.62k \quad (46)$$

$$R4 = \frac{2.5V \times R3}{(V_{OVH} - 2.5V)} = \frac{2.5V \times 47.62k}{(31V - 2.5V)} = 4.18k \quad (47)$$

Nearest available 1% resistors must be chosen. Set R1 = 47.5 kΩ, R2 = 8.25 kΩ, R3 = 47.5 kΩ, and R4 = 4.22 kΩ.



9.2.1.2.7 Input and Output Protection

Proper operation of the LM5069 hot swap circuit requires a voltage clamping element present on the supply side of the connector into which the hot swap circuit is plugged in. A TVS is ideal, as depicted in Figure 27. The TVS is necessary to absorb the voltage transient generated whenever the hot swap circuit shuts off the load current. This effect is the most severe during a hot-short when a large current is suddenly interrupted when the FET shuts off. The TVS must be chosen to have minimal leakage current at  $V_{IN,MAX}$  and to clamp the voltage to under 30 V during hot-short events. For many high-power applications intended to clamp at 30 V, SMBJ30A-13-F is a good choice.

9.2.1.2.8 Final Schematic and Component Values

Figure 27 shows the schematic used to implement the requirements described in the previous section. In addition, Table 2 below provides the final component values that were used to meet the design requirements for a 12-V, 40-A hot swap design. The Application Curves are based on these component values.

Table 2. Component Values

| COMPONENT          | VALUE        |
|--------------------|--------------|
| Rsns               | 4 mΩ         |
| R1                 | 47.5 kΩ      |
| R2                 | 8.25 kΩ      |
| R3                 | 47.5 kΩ      |
| R4                 | 4.22 kΩ      |
| R <sub>PWR</sub>   | 15.8 kΩ      |
| Q1                 | CSD19536KTT  |
| Z1                 | SMBJ30A-13-F |
| D1                 | MBR3100      |
| C <sub>TIMER</sub> | 150 nF       |
| C <sub>OUT</sub>   | 330 μF       |

9.2.1.3 Application Curves

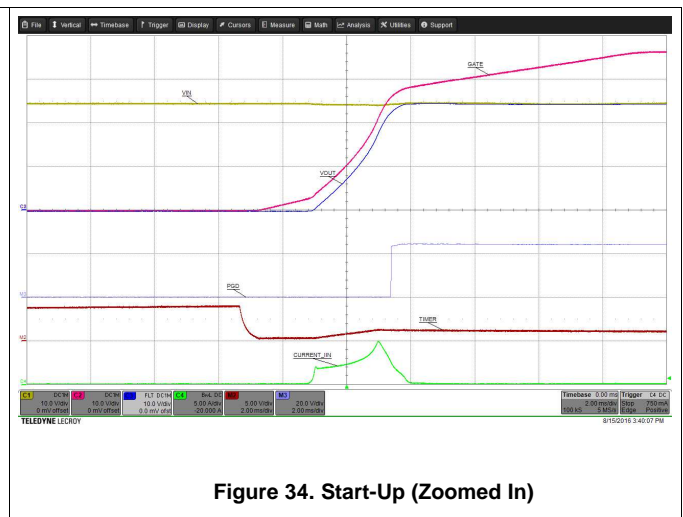
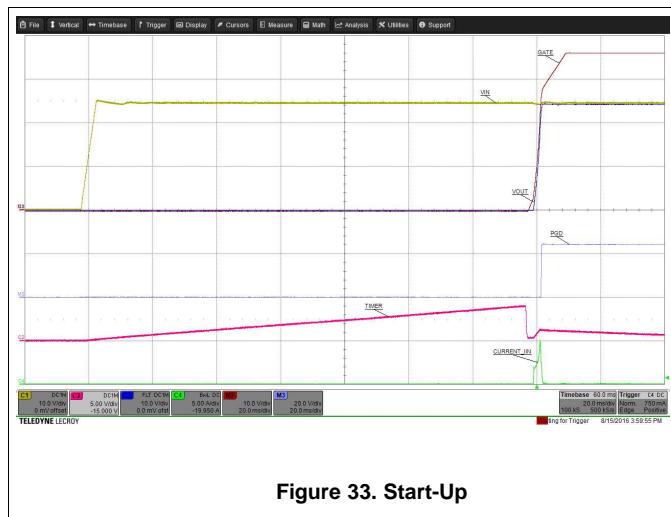

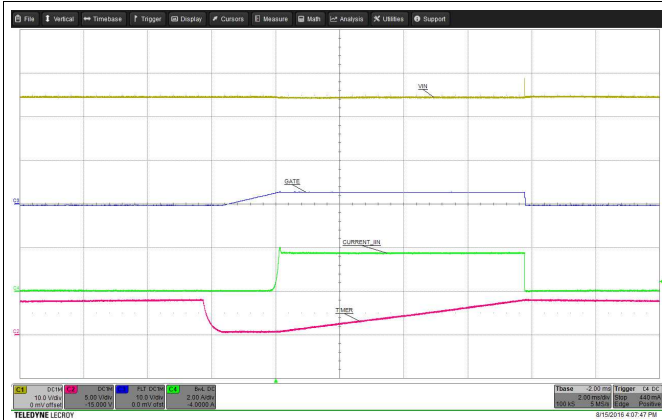

Figure 35. Start-Up into Short Circuit



Figure 36. Undervoltage

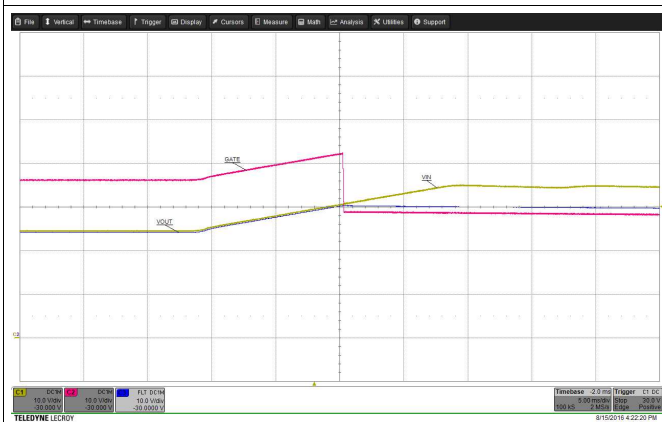

Figure 37. Overvoltage

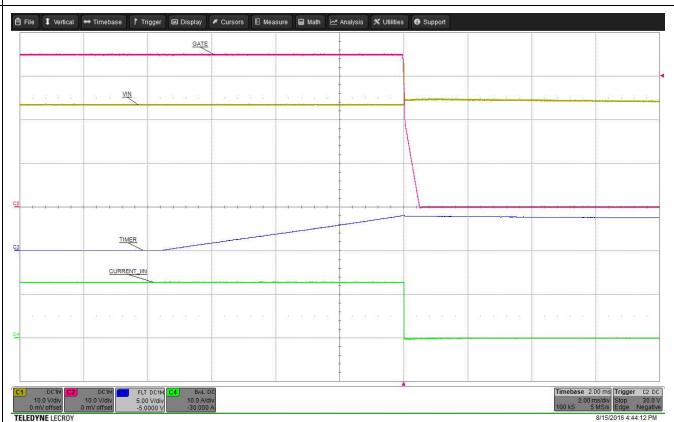

Figure 38. Gradual Overcurrent

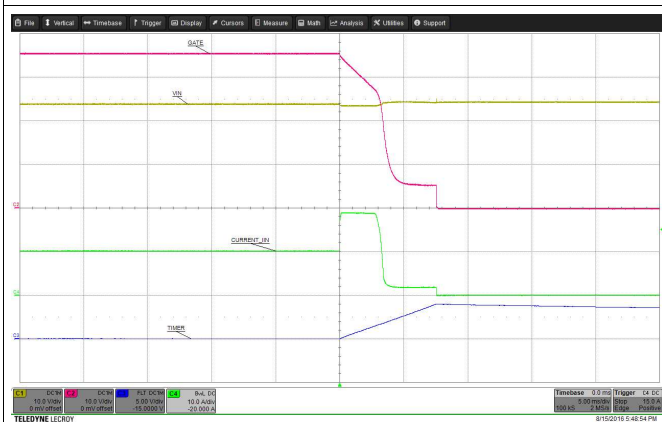

Figure 39. Load Step

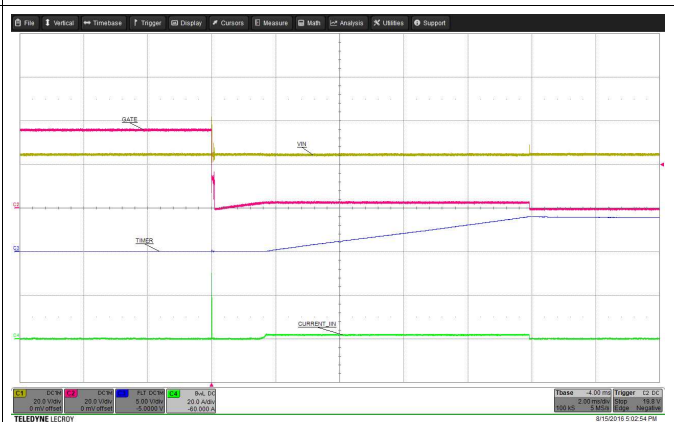

Figure 40. Hot-Short on Output



Figure 41. Hot-Short (Zoomed In)

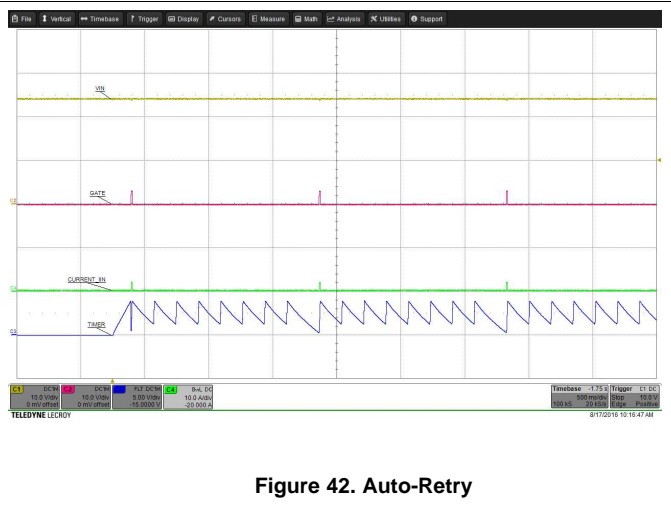

Figure 42. Auto-Retry

## 10 Power Supply Recommendations

In general, the LM5069 behavior is more reliable if it is supplied from a very regulated power supply. However, high-frequency transients on a backplane are not uncommon due to adjacent card insertions or faults. If this is expected in the end system, TI recommends placing a 1- $\mu$ F ceramic capacitor to ground close to the drain of the hot swap MOSFET. This reduces the common mode voltage seen by VIN and SENSE. Additional filtering may be necessary to avoid nuisance trips.

## 11 Layout

### 11.1 Layout Guidelines

#### 11.1.1 PC Board Guidelines

The following guidelines must be followed when designing the PC board for the LM5069:

- Place the LM5069 close to the board's input connector to minimize trace inductance from the connector to the FET.
- Note that special care must be taken when placing the bypass capacitor for the VIN pin. During hot shorts, there is a very large  $dV/dt$  on input voltage after the MOSFET turns off. If the bypass capacitor is placed right next to the pin and the trace from  $R_{Sns}$  to the pin is long, an LC filter is formed. As a result, a large differential voltage can develop between VIN and SENSE. To avoid this, place the bypass capacitor close to  $R_{Sns}$  instead of the VIN pin.

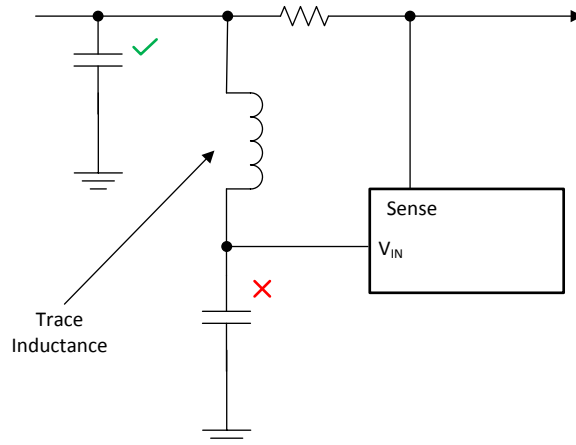

**Figure 43. Layout Trace Inductance**

- The sense resistor ( $R_S$ ) must be close to the LM5069, and connected to it using the Kelvin techniques shown in [Figure 46](#).
- The high current path from the board's input to the load (via Q1), and the return path, must be parallel and close to each other to minimize loop inductance.
- The ground connection for the various components around the LM5069 must be connected directly to each other, and to the LM5069's GND pin, and then connected to the system ground at one point. Do not connect the various component grounds to each other through the high current ground line.
- Provide adequate heat sinking for the series pass device (Q1) to help reduce stresses during turnon and turnoff.
- The board's edge connector can be designed to shut off the LM5069 as the board is removed, before the supply voltage is disconnected from the LM5069. In [Figure 45](#) the voltage at the UVLO pin goes to ground before  $V_{SYS}$  is removed from the LM5069 due to the shorter edge connector pin. When the board is inserted into the edge connector, the system voltage is applied to the LM5069's VIN pin before the UVLO voltage is taken high.

#### 11.1.2 System Considerations

A) Continued proper operation of the LM5069 hot swap circuit requires capacitance be present on the supply side of the connector into which the hot swap circuit is plugged in, as depicted in [Figure 44](#). The capacitor in the *Live Backplane* section is necessary to absorb the transient generated whenever the hot swap circuit shuts off the load current. If the capacitance is not present, inductance in the supply lines generate a voltage transient at shut-off which can exceed the absolute maximum rating of the LM5069, resulting in its destruction.

B) If the load powered via the LM5069 hot swap circuit has inductive characteristics, a diode is required across the LM5069's output. The diode provides a recirculating path for the load's current when the LM5069 shuts off that current. Adding the diode prevents possible damage to the LM5069 as the OUT pin is taken below ground by the inductive load at shutoff. See [Figure 44](#).

Layout Guidelines (continued)

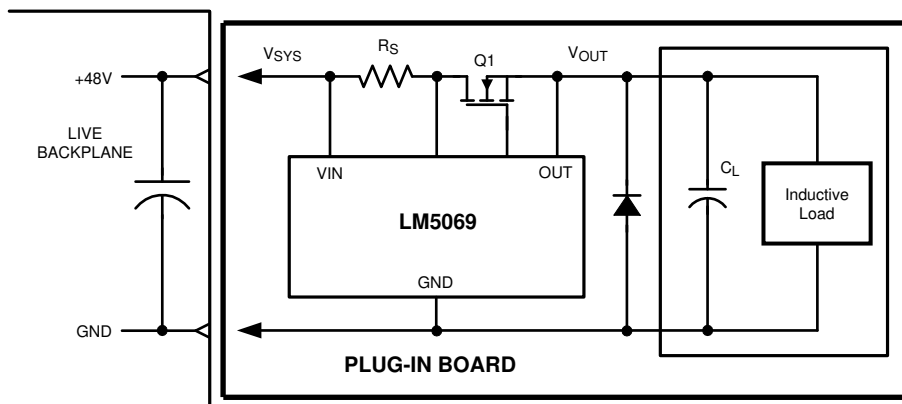

Copyright © 2016, Texas Instruments Incorporated

Figure 44. Output Diode Required for Inductive Loads

11.2 Layout Example

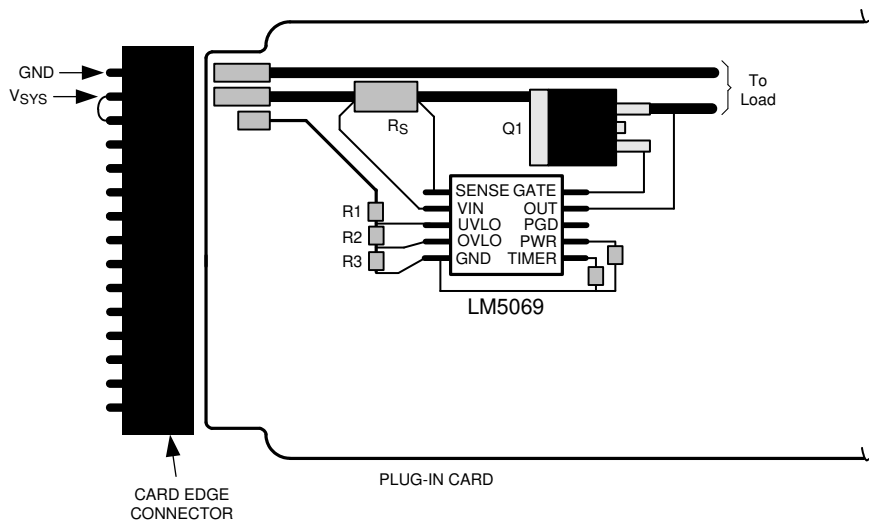

Copyright © 2016, Texas Instruments Incorporated

Figure 45. Recommended Board Connector Design

Layout Example (continued)

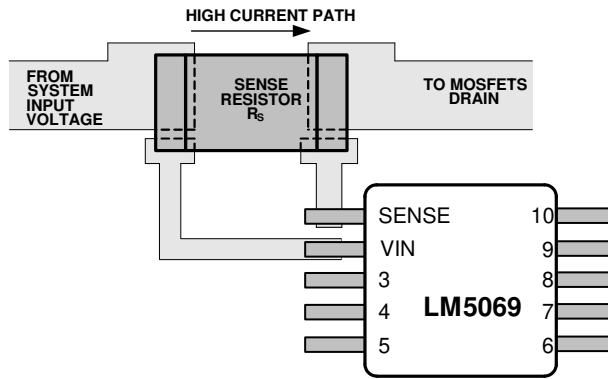

Copyright © 2016, Texas Instruments Incorporated

Figure 46. Sense Resistor Connections

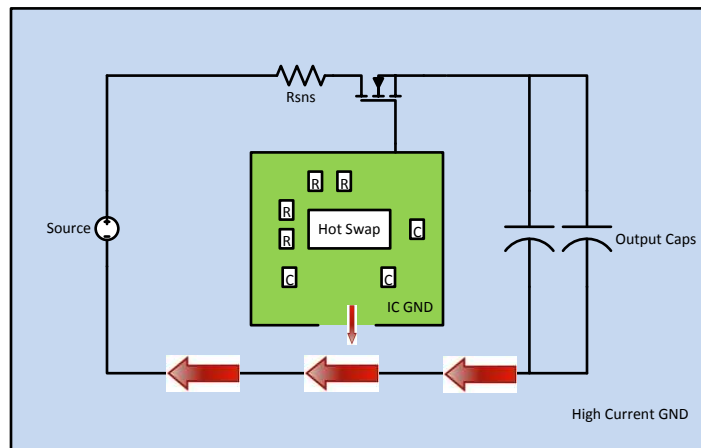

Figure 47. LM5069 Quiet IC Ground Layout

## 12 器件和文档支持

### 12.1 器件支持

#### 12.1.1 开发支持

要了解 LM5069 设计计算器，请前往 [ti.com.cn](http://ti.com.cn) 查看产品文件夹下的[工具和软件](#)。

### 12.2 文档支持

#### 12.2.1 相关文档

请参阅如下相关文档：

- [《焊接的绝对最大额定值》](#) (SNOA549)
- [可靠的热插拔设计](#) (SLVA673)

### 12.3 接收文档更新通知

要接收文档更新通知，请导航至 [ti.com.cn](http://ti.com.cn) 上的器件产品文件夹。单击右上角的[通知我](#)进行注册，即可每周接收产品信息更改摘要。有关更改的详细信息，请查看任何已修订文档中包含的修订历史记录。

### 12.4 社区资源

[TI E2E™ support forums](#) are an engineer's go-to source for fast, verified answers and design help — straight from the experts. Search existing answers or ask your own question to get the quick design help you need.

Linked content is provided "AS IS" by the respective contributors. They do not constitute TI specifications and do not necessarily reflect TI's views; see TI's [Terms of Use](#).

### 12.5 商标

E2E is a trademark of Texas Instruments.

All other trademarks are the property of their respective owners.

### 12.6 静电放电警告



这些装置包含有限的内置 ESD 保护。存储或装卸时，应将导线一起截短或将装置放置于导电泡棉中，以防止 MOS 门极遭受静电损伤。

### 12.7 Glossary

[SLYZ022](#) — *TI Glossary*.

This glossary lists and explains terms, acronyms, and definitions.

## 13 机械、封装和可订购信息

以下页面包含机械、封装和可订购信息。这些信息是指定器件的最新可用数据。数据如有变更，恕不另行通知，且不会对此文档进行修订。如需获取此数据表的浏览器版本，请查阅左侧的导航栏。

**PACKAGING INFORMATION**

| Orderable part number            | Status<br>(1) | Material type<br>(2) | Package   Pins   | Package qty   Carrier | RoHS<br>(3) | Lead finish/<br>Ball material<br>(4) | MSL rating/<br>Peak reflow<br>(5) | Op temp (°C) | Part marking<br>(6) |
|----------------------------------|---------------|----------------------|------------------|-----------------------|-------------|--------------------------------------|-----------------------------------|--------------|---------------------|
| <a href="#">LM5069MM-1/NOPB</a>  | Active        | Production           | VSSOP (DGS)   10 | 1000   SMALL T&R      | Yes         | SN                                   | Level-1-260C-UNLIM                | -40 to 125   | SNAB                |
| LM5069MM-1/NOPB.A                | Active        | Production           | VSSOP (DGS)   10 | 1000   SMALL T&R      | Yes         | SN                                   | Level-1-260C-UNLIM                | -40 to 125   | SNAB                |
| LM5069MM-1/NOPB.B                | Active        | Production           | VSSOP (DGS)   10 | 1000   SMALL T&R      | Yes         | SN                                   | Level-1-260C-UNLIM                | -40 to 125   | SNAB                |
| <a href="#">LM5069MM-2/NOPB</a>  | Active        | Production           | VSSOP (DGS)   10 | 1000   SMALL T&R      | Yes         | SN                                   | Level-1-260C-UNLIM                | -40 to 125   | SNBB                |
| LM5069MM-2/NOPB.A                | Active        | Production           | VSSOP (DGS)   10 | 1000   SMALL T&R      | Yes         | SN                                   | Level-1-260C-UNLIM                | -40 to 125   | SNBB                |
| LM5069MM-2/NOPB.B                | Active        | Production           | VSSOP (DGS)   10 | 1000   SMALL T&R      | Yes         | SN                                   | Level-1-260C-UNLIM                | -40 to 125   | SNBB                |
| <a href="#">LM5069MMX-1/NOPB</a> | Active        | Production           | VSSOP (DGS)   10 | 3500   LARGE T&R      | Yes         | SN                                   | Level-1-260C-UNLIM                | -40 to 125   | SNAB                |
| LM5069MMX-1/NOPB.A               | Active        | Production           | VSSOP (DGS)   10 | 3500   LARGE T&R      | Yes         | SN                                   | Level-1-260C-UNLIM                | -40 to 125   | SNAB                |
| LM5069MMX-1/NOPB.B               | Active        | Production           | VSSOP (DGS)   10 | 3500   LARGE T&R      | Yes         | SN                                   | Level-1-260C-UNLIM                | -40 to 125   | SNAB                |
| <a href="#">LM5069MMX-2/NOPB</a> | Active        | Production           | VSSOP (DGS)   10 | 3500   LARGE T&R      | Yes         | SN                                   | Level-1-260C-UNLIM                | -40 to 125   | SNBB                |
| LM5069MMX-2/NOPB.A               | Active        | Production           | VSSOP (DGS)   10 | 3500   LARGE T&R      | Yes         | SN                                   | Level-1-260C-UNLIM                | -40 to 125   | SNBB                |
| LM5069MMX-2/NOPB.B               | Active        | Production           | VSSOP (DGS)   10 | 3500   LARGE T&R      | Yes         | SN                                   | Level-1-260C-UNLIM                | -40 to 125   | SNBB                |

(1) **Status:** For more details on status, see our [product life cycle](#).

(2) **Material type:** When designated, preproduction parts are prototypes/experimental devices, and are not yet approved or released for full production. Testing and final process, including without limitation quality assurance, reliability performance testing, and/or process qualification, may not yet be complete, and this item is subject to further changes or possible discontinuation. If available for ordering, purchases will be subject to an additional waiver at checkout, and are intended for early internal evaluation purposes only. These items are sold without warranties of any kind.

(3) **RoHS values:** Yes, No, RoHS Exempt. See the [TI RoHS Statement](#) for additional information and value definition.

(4) **Lead finish/Ball material:** Parts may have multiple material finish options. Finish options are separated by a vertical ruled line. Lead finish/Ball material values may wrap to two lines if the finish value exceeds the maximum column width.

(5) **MSL rating/Peak reflow:** The moisture sensitivity level ratings and peak solder (reflow) temperatures. In the event that a part has multiple moisture sensitivity ratings, only the lowest level per JEDEC standards is shown. Refer to the shipping label for the actual reflow temperature that will be used to mount the part to the printed circuit board.

(6) **Part marking:** There may be an additional marking, which relates to the logo, the lot trace code information, or the environmental category of the part.

Multiple part markings will be inside parentheses. Only one part marking contained in parentheses and separated by a "-" will appear on a part. If a line is indented then it is a continuation of the previous line and the two combined represent the entire part marking for that device.



**Important Information and Disclaimer:** The information provided on this page represents TI's knowledge and belief as of the date that it is provided. TI bases its knowledge and belief on information provided by third parties, and makes no representation or warranty as to the accuracy of such information. Efforts are underway to better integrate information from third parties. TI has taken and continues to take reasonable steps to provide representative and accurate information but may not have conducted destructive testing or chemical analysis on incoming materials and chemicals. TI and TI suppliers consider certain information to be proprietary, and thus CAS numbers and other limited information may not be available for release.

In no event shall TI's liability arising out of such information exceed the total purchase price of the TI part(s) at issue in this document sold by TI to Customer on an annual basis.

**TAPE AND REEL INFORMATION**

**QUADRANT ASSIGNMENTS FOR PIN 1 ORIENTATION IN TAPE**

\*All dimensions are nominal

| Device           | Package Type | Package Drawing | Pins | SPQ  | Reel Diameter (mm) | Reel Width W1 (mm) | A0 (mm) | B0 (mm) | K0 (mm) | P1 (mm) | W (mm) | Pin1 Quadrant |
|------------------|--------------|-----------------|------|------|--------------------|--------------------|---------|---------|---------|---------|--------|---------------|
| LM5069MM-1/NOPB  | VSSOP        | DGS             | 10   | 1000 | 177.8              | 12.4               | 5.3     | 3.4     | 1.4     | 8.0     | 12.0   | Q1            |
| LM5069MM-2/NOPB  | VSSOP        | DGS             | 10   | 1000 | 177.8              | 12.4               | 5.3     | 3.4     | 1.4     | 8.0     | 12.0   | Q1            |
| LM5069MMX-1/NOPB | VSSOP        | DGS             | 10   | 3500 | 330.0              | 12.4               | 5.3     | 3.4     | 1.4     | 8.0     | 12.0   | Q1            |
| LM5069MMX-2/NOPB | VSSOP        | DGS             | 10   | 3500 | 330.0              | 12.4               | 5.3     | 3.4     | 1.4     | 8.0     | 12.0   | Q1            |

**TAPE AND REEL BOX DIMENSIONS**

\*All dimensions are nominal

| Device           | Package Type | Package Drawing | Pins | SPQ  | Length (mm) | Width (mm) | Height (mm) |
|------------------|--------------|-----------------|------|------|-------------|------------|-------------|
| LM5069MM-1/NOPB  | VSSOP        | DGS             | 10   | 1000 | 208.0       | 191.0      | 35.0        |
| LM5069MM-2/NOPB  | VSSOP        | DGS             | 10   | 1000 | 208.0       | 191.0      | 35.0        |
| LM5069MMX-1/NOPB | VSSOP        | DGS             | 10   | 3500 | 367.0       | 367.0      | 35.0        |
| LM5069MMX-2/NOPB | VSSOP        | DGS             | 10   | 3500 | 367.0       | 367.0      | 35.0        |

# DGS0010A



# PACKAGE OUTLINE

## VSSOP - 1.1 mm max height

SMALL OUTLINE PACKAGE



### NOTES:

1. All linear dimensions are in millimeters. Any dimensions in parenthesis are for reference only. Dimensioning and tolerancing per ASME Y14.5M.
2. This drawing is subject to change without notice.
3. This dimension does not include mold flash, protrusions, or gate burrs. Mold flash, protrusions, or gate burrs shall not exceed 0.15 mm per side.
4. This dimension does not include interlead flash. Interlead flash shall not exceed 0.25 mm per side.
5. Reference JEDEC registration MO-187, variation BA.

# EXAMPLE BOARD LAYOUT

DGS0010A

VSSOP - 1.1 mm max height

SMALL OUTLINE PACKAGE



LAND PATTERN EXAMPLE  
SCALE:10X



SOLDER MASK DETAILS  
NOT TO SCALE

4221984/A 05/2015

NOTES: (continued)

- 6. Publication IPC-7351 may have alternate designs.
- 7. Solder mask tolerances between and around signal pads can vary based on board fabrication site.

# EXAMPLE STENCIL DESIGN

DGS0010A

VSSOP - 1.1 mm max height

SMALL OUTLINE PACKAGE



SOLDER PASTE EXAMPLE  
BASED ON 0.125 mm THICK STENCIL  
SCALE:10X

4221984/A 05/2015

NOTES: (continued)

8. Laser cutting apertures with trapezoidal walls and rounded corners may offer better paste release. IPC-7525 may have alternate design recommendations.
9. Board assembly site may have different recommendations for stencil design.

## 重要通知和免责声明

TI“按原样”提供技术和可靠性数据（包括数据表）、设计资源（包括参考设计）、应用或其他设计建议、网络工具、安全信息和其他资源，不保证没有瑕疵且不做任何明示或暗示的担保，包括但不限于对适销性、与某特定用途的适用性或不侵犯任何第三方知识产权的暗示担保。

这些资源可供使用 TI 产品进行设计的熟练开发人员使用。您将自行承担以下全部责任：(1) 针对您的应用选择合适的 TI 产品，(2) 设计、验证并测试您的应用，(3) 确保您的应用满足相应标准以及任何其他安全、安保法规或其他要求。

这些资源如有变更，恕不另行通知。TI 授权您仅可将这些资源用于研发本资源所述的 TI 产品的相关应用。严禁以其他方式对这些资源进行复制或展示。您无权使用任何其他 TI 知识产权或任何第三方知识产权。对于因您对这些资源的使用而对 TI 及其代表造成的任何索赔、损害、成本、损失和债务，您将全额赔偿，TI 对此概不负责。

TI 提供的产品受 [TI 销售条款](#)、[TI 通用质量指南](#) 或 [ti.com](#) 上其他适用条款或 TI 产品随附的其他适用条款的约束。TI 提供这些资源并不会扩展或以其他方式更改 TI 针对 TI 产品发布的适用的担保或担保免责声明。除非德州仪器 (TI) 明确将某产品指定为定制产品或客户特定产品，否则其产品均为按确定价格收入目录的标准通用器件。

TI 反对并拒绝您可能提出的任何其他或不同的条款。

版权所有 © 2025，德州仪器 (TI) 公司

最后更新日期：2025 年 10 月