

SNx4HC244 具有三态输出的八路缓冲器和线路驱动器

1 特性

- 2V 至 6V 的宽工作电压范围
- 高电流输出可驱动多达 15 个 LSTTL 负载
- 三态输出驱动总线或缓冲存储器地址寄存器
- 低功耗： I_{CC} ，80 μ A (最大值)
- t_{pd} 典型值 = 11ns
- 5V 时，输出驱动为 ± 6 mA
- 1 μ A 低输入电流 (最大值)
- 对于符合 MIL-PRF-38535 标准的产品，所有参数均经过测试，除非另有说明。对于所有其他产品，生产流程不一定包含对所有参数的测试。

2 应用

- 服务器
- 发光二极管 (LED) 显示屏
- 网络交换机
- 电信基础设施
- 电机驱动器
- I/O 扩展器

3 说明

SNx4HC244 八路缓冲器和线路驱动器专门设计用于提高三态存储器地址驱动器、时钟驱动器以及总线导向接收器和发送器的性能和密度。SNx4HC244 器件配备两个具有独立输出使能 (\overline{OE}) 输入的 4 位缓冲器和驱动器。当 \overline{OE} 为低电平时，该器件将来自 A 输入的同相数据传递到 Y 输出。当 \overline{OE} 为高电平时，输出处于高阻态。

封装信息

器件型号	封装 ⁽¹⁾	封装尺寸 ⁽²⁾	本体尺寸 ⁽³⁾
SN54HC244	J (CDIP , 20)	24.38mm × 7.62mm	24.38mm × 6.92mm
	W (CFP , 20)	13.72mm × 8.13mm	13.72mm × 6.92mm
	FK (LCCC , 20)	8.89mm × 8.89mm	8.89mm × 8.89mm
SN74HC244	DB (SSOP , 20)	7.2mm × 7.8mm	7.2mm × 5.3mm
	DW (SOIC , 20)	12.80mm × 10.3mm	12.8mm × 7.5mm
	N (PDIP , 20)	24.33mm × 9.4mm	24.33mm × 6.35mm
	NS (SOP , 20)	12.6mm × 7.8mm	12.6mm × 5.3mm
	PW (TSSOP , 20)	6.5mm × 6.4mm	6.5mm × 4.4mm

- (1) 如需了解更多信息，请参阅[机械、封装和可订购信息](#)。
- (2) 封装尺寸 (长 × 宽) 为标称值，并包括引脚 (如适用)。
- (3) 封装尺寸 (长 × 宽) 为标称值，不包括引脚。

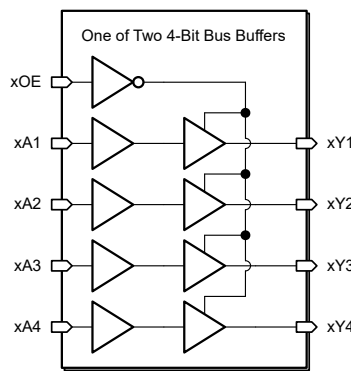

逻辑图 (正逻辑)



内容

1 特性	1	7.1 概述.....	14
2 应用	1	7.2 功能方框图.....	14
3 说明	1	7.3 特性说明.....	14
4 引脚配置和功能	3	7.4 器件功能模式.....	14
5 规格	4	8 应用和实施	15
5.1 绝对最大额定值.....	4	8.1 应用信息.....	15
5.2 ESD 等级.....	4	8.2 典型应用.....	15
5.3 建议运行条件.....	4	8.3 电源相关建议.....	17
5.4 热性能信息.....	5	8.4 布局指南.....	17
5.5 电气特性.....	5	9 器件和文档支持	19
5.6 电气特性 - -55°C - 125°C	5	9.1 文档支持.....	19
5.7 电气特性 - -40°C - 125°C	6	9.2 接收文档更新通知.....	19
5.8 电气特性 - -40°C - 85°C	6	9.3 支持资源.....	19
5.9 开关特性.....	7	9.4 商标.....	19
5.10 开关特性 - $C_L = 50\text{pF}$	7	9.5 静电放电警告.....	19
5.11 开关特性 - $C_L = 150\text{pF}$	9	9.6 术语表.....	19
5.12 典型特性.....	11	10 修订历史记录	19
6 参数测量信息	12	11 机械、封装和可订购信息	19
7 详细说明	14		

4 引脚配置和功能



图 4-1. DB、DW、J、N、NS、PW、W 封装 20 引脚 SSOP、SOIC、CDIP、PDIP、SOP、TSSOP 或 CFP 顶视图



图 4-2. FK 封装 20 引脚 LCCC 顶视图

引脚		类型 ⁽¹⁾	说明
名称	编号		
1A1	2	I	输入
1A2	4	I	输入
1A3	6	I	输入
1A4	8	I	输入
1OE	1	I	输出使能
1Y1	18	O	输出
1Y2	16	O	输出
1Y3	14	O	输出
1Y4	12	O	输出
2A1	11	I	输入
2A2	13	I	输入
2A3	15	I	输入
2A4	17	I	输入
2OE	19	I	输出使能
2Y1	9	O	输出
2Y2	7	O	输出
2Y3	5	O	输出
2Y4	3	O	输出
GND	10	—	接地
V _{CC}	20	—	电源引脚

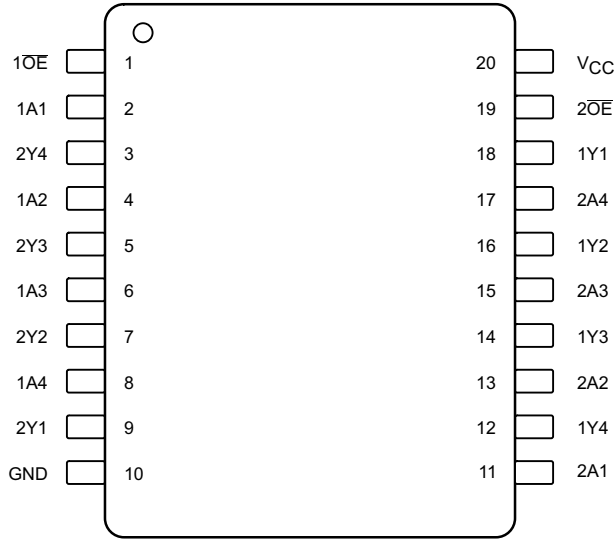
(1) 信号类型：I = 输入，O = 输出

5 规格

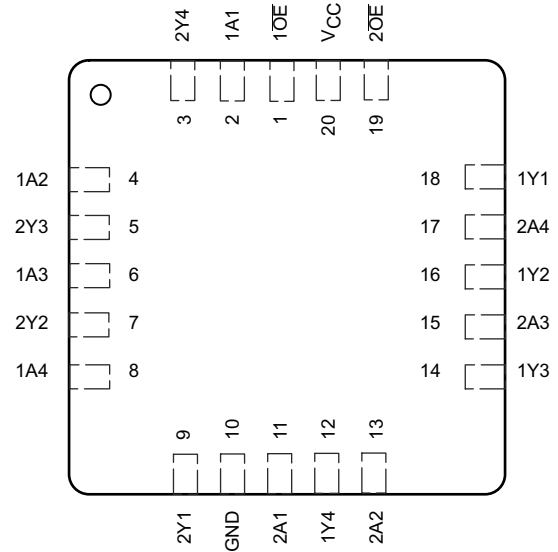
5.1 绝对最大额定值

在自然通风条件下的工作温度范围内测得 (除非另有说明) ⁽¹⁾

		最小值	最大值	单位
电源电压范围, V_{CC}		-0.5	7	V
输入钳位电流, I_{IK}	$V_I < 0$ 或 $V_I > V_{CC}$ ⁽²⁾		±20	mA
输出钳位电流, I_{OK}	$V_O < 0$ 或 $V_O > V_{CC}$ ⁽²⁾		±20	mA
持续输出电流, I_O	$V_O = 0$ 或 V_{CC}		±35	mA
通过 V_{CC} 或 GND 的持续电流			±70	mA
结温 T_J			150	°C
贮存温度, T_{stg}		-65	150	°C

- (1) 超出绝对最大额定值范围操作可能会导致器件永久损坏。绝对最大额定值并不表示器件在这些条件下或在建议的工作条件以外的任何其他条件下能够正常运行。如果超出建议运行条件但在绝对最大额定值范围内使用, 器件可能不会完全正常运行, 这可能影响器件的可靠性、功能和性能并缩短器件寿命。
- (2) 如果遵守输入和输出电流额定值, 输入和输出电压可超过额定值。

5.2 ESD 等级

SN74HC244		值	单位
$V_{(ESD)}$ 静电放电	人体放电模型 (HBM), 符合 ANSI/ESDA/JEDEC JS-001 标准 ⁽¹⁾	±2000	V
	充电器件模型 (CDM), 符合 JEDEC 规范 JESD22-C101 ⁽²⁾	±1000	

- (1) JEDEC 文档 JEP155 指出: 500V HBM 时能够在标准 ESD 控制流程下安全生产。
- (2) JEDEC 文档 JEP157 指出: 250V CDM 时能够在标准 ESD 控制流程下安全生产。

5.3 建议运行条件

在自然通风条件下的工作温度范围内测得 (除非另有说明) ⁽¹⁾

		最小值	标称值	最大值	单位
V_{CC}	电源电压	2	5	6	V
V_{IH}	高电平输入电压	$V_{CC} = 2V$			V
		$V_{CC} = 4.5V$	3.15		
		$V_{CC} = 6V$	4.2		
V_{IL}	低电平输入电压	$V_{CC} = 2V$		0.5	V
		$V_{CC} = 4.5V$		1.35	
		$V_{CC} = 6V$		1.8	
V_I	输入电压	0		V_{CC}	V
V_O	输出电压	0		V_{CC}	V
$\Delta t / \Delta v$	输入转换上升和下降时间	$V_{CC} = 2V$		1000	ns/V
		$V_{CC} = 4.5V$		500	
		$V_{CC} = 6V$		400	
C_{pd}	每个缓冲器或驱动器的功率耗散电容 (无负载)		35		pF
T_A	自然通风条件下的工作温度	SN54HC244	-55	125	°C
		SN74HC244	-40	125	

- (1) 器件的所有未使用输入必须保持在 V_{CC} 或 GND, 以确保器件正常运行。请参阅 TI 应用手册 [慢速或浮点 CMOS 输入的影响](#)。

5.4 热性能信息

热指标		SN74HC244					单位
		DW (SOIC)	DB (SSOP)	N (PDIP)	NS (SO)	PW (TSSOP)	
		20 引脚	20 引脚	20 引脚	20 引脚	20 引脚	
$R_{\theta JA}$	结至环境热阻 ⁽¹⁾	109.1	122.7	84.6	113.4	131.8	°C/W
$R_{\theta JC(top)}$	结至外壳 (顶部) 热阻	76	81.6	72.5	78.6	72.2	°C/W
$R_{\theta JB}$	结至电路板热阻	77.6	77.5	65.3	78.4	82.8	°C/W
Ψ_{JT}	结至顶部特征参数	51.5	46.1	55.3	47.1	21.5	°C/W
Ψ_{JB}	结至电路板特征参数	77.1	77.1	65.2	78.1	82.4	°C/W
$R_{\theta JC(bot)}$	结至外壳 (底部) 热阻	不适用	不适用	不适用	不适用	不适用	°C/W

(1) 有关新旧热指标的更多信息, 请参阅 [半导体和 IC 封装热指标应用手册](#)。

5.5 电气特性

$T_A = 25^\circ\text{C}$ (除非另有说明)

参数	测试条件		最小值	典型值	最大值	单位
V_{OH}	$V_I = V_{IH}$ 或 V_{IL}	$I_{OH} = -20\mu\text{A}$	$V_{CC} = 2\text{V}$	1.9	1.998	V
			$V_{CC} = 4.5\text{V}$	4.4	4.499	
			$V_{CC} = 6\text{V}$	5.9	5.999	
		$I_{OH} = -6\text{mA}, V_{CC} = 4.5\text{V}$	3.98	4.3		
		$I_{OH} = -7.8\text{mA}, V_{CC} = 6\text{V}$	5.48	5.8		
V_{OL}	$V_I = V_{IH}$ 或 V_{IL}	$I_{OL} = 20\mu\text{A}$	$V_{CC} = 2\text{V}$	0.002	0.1	V
			$V_{CC} = 4.5\text{V}$	0.001	0.1	
			$V_{CC} = 6\text{V}$	0.001	0.1	
		$I_{OL} = 6\text{mA}, V_{CC} = 4.5\text{V}$	0.17	0.26		
		$I_{OL} = 7.8\text{mA}, V_{CC} = 6\text{V}$	0.15	0.26		
I_I	$V_I = V_{CC}$ 或 0, $V_{CC} = 6\text{V}$			± 0.1	± 100	nA
I_{OZ}	$V_O = V_{CC}$ 或 0, $V_I = V_{IH}$ 或 V_{IL} , $V_{CC} = 6\text{V}$			± 0.01	± 0.5	μA
I_{CC}	$V_I = V_{CC}$ 或 0, $I_O = 0$, $V_{CC} = 6\text{V}$				8	μA
C_i	$V_{CC} = 2\text{V}$ 至 6V			3	10	pF

5.6 电气特性 - -55°C - 125°C

在自然通风条件下的建议运行温度范围内测得 (除非另有说明)

参数	测试条件		最小值	典型值	最大值	单位
V_{OH}	$V_I = V_{IH}$ 或 V_{IL}	$I_{OH} = -20\mu\text{A}$	$V_{CC} = 2\text{V}$	1.9		V
			$V_{CC} = 4.5\text{V}$	4.4		
			$V_{CC} = 6\text{V}$	5.9		
		$I_{OH} = -6\text{mA}, V_{CC} = 4.5\text{V}$	3.7			
		$I_{OH} = -7.8\text{mA}, V_{CC} = 6\text{V}$	5.2			
V_{OL}	$V_I = V_{IH}$ 或 V_{IL}	$I_{OL} = 20\mu\text{A}$	$V_{CC} = 2\text{V}$		0.1	V
			$V_{CC} = 4.5\text{V}$		0.1	
			$V_{CC} = 6\text{V}$		0.1	
		$I_{OL} = 6\text{mA}, V_{CC} = 4.5\text{V}$		0.4		
		$I_{OL} = 7.8\text{mA}, V_{CC} = 6\text{V}$		0.4		
I_I	$V_I = V_{CC}$ 或 0, $V_{CC} = 6\text{V}$				± 1000	nA

在自然通风条件下的建议运行温度范围内测得 (除非另有说明)

参数	测试条件	最小值	典型值	最大值	单位
I_{OZ}	$V_O = V_{CC}$ 或 0, $V_I = V_{IH}$ 或 V_{IL} , $V_{CC} = 6V$			±10	μA
I_{CC}	$V_I = V_{CC}$ 或 0, $I_O = 0$, $V_{CC} = 6V$			160	μA
C_i	$V_{CC} = 2V$ 至 $6V$			10	pF

5.7 电气特性 - -40°C - 125°C

在自然通风条件下的建议运行温度范围内测得 (除非另有说明)

参数	测试条件		最小值	典型值	最大值	单位
V_{OH}	$V_I = V_{IH}$ 或 V_{IL}	$I_{OH} = -20\mu A$	$V_{CC} = 2V$		1.9	V
			$V_{CC} = 4.5V$		4.4	
			$V_{CC} = 6V$		5.9	
		$I_{OH} = -6mA, V_{CC} = 4.5V$		3.7		
		$I_{OH} = -7.8mA, V_{CC} = 6V$			5.2	
V_{OL}	$V_I = V_{IH}$ 或 V_{IL}	$I_{OL} = 20\mu A$	$V_{CC} = 2V$		0.1	V
			$V_{CC} = 4.5V$		0.1	
			$V_{CC} = 6V$		0.1	
		$I_{OL} = 6mA, V_{CC} = 4.5V$		0.4		
		$I_{OL} = 7.8mA, V_{CC} = 6V$			0.4	
I_I	$V_I = V_{CC}$ 或 0, $V_{CC} = 6V$				±1000	nA
I_{OZ}	$V_O = V_{CC}$ 或 0, $V_I = V_{IH}$ 或 V_{IL} , $V_{CC} = 6V$				±10	μA
I_{CC}	$V_I = V_{CC}$ 或 0, $I_O = 0$, $V_{CC} = 6V$				160	μA
C_i	$V_{CC} = 2V$ 至 $6V$				10	pF

5.8 电气特性 - -40°C - 85°C

在自然通风条件下的建议运行温度范围内测得 (除非另有说明)

参数	测试条件		最小值	典型值	最大值	单位
V_{OH}	$V_I = V_{IH}$ 或 V_{IL}	$I_{OH} = -20\mu A$	$V_{CC} = 2V$		1.9	V
			$V_{CC} = 4.5V$		4.4	
			$V_{CC} = 6V$		5.9	
		$I_{OH} = -6mA, V_{CC} = 4.5V$		3.84		
		$I_{OH} = -7.8mA, V_{CC} = 6V$			5.34	
V_{OL}	$V_I = V_{IH}$ 或 V_{IL}	$I_{OL} = 20\mu A$	$V_{CC} = 2V$		0.1	V
			$V_{CC} = 4.5V$		0.1	
			$V_{CC} = 6V$		0.1	
		$I_{OL} = 6mA, V_{CC} = 4.5V$		0.33		
		$I_{OL} = 7.8mA, V_{CC} = 6V$			0.33	
I_I	$V_I = V_{CC}$ 或 0, $V_{CC} = 6V$				±1000	nA
I_{OZ}	$V_O = V_{CC}$ 或 0, $V_I = V_{IH}$ 或 V_{IL} , $V_{CC} = 6V$				±5	μA
I_{CC}	$V_I = V_{CC}$ 或 0, $I_O = 0$, $V_{CC} = 6V$				80	μA
C_i	$V_{CC} = 2V$ 至 $6V$				10	pF

5.9 开关特性

$T_A = 25^\circ\text{C}$ (除非另有说明; 请参阅图 6-1)

参数	测试条件		最小值	典型值	最大值	单位	
t_{pd}	从 A (输入) 到 Y (输出)	$V_{CC} = 2\text{V}$	$C_L = 50\text{pF}$		40	115	ns
			$C_L = 150\text{pF}$		56	165	
		$V_{CC} = 4.5\text{V}$	$C_L = 50\text{pF}$		13	23	
			$C_L = 150\text{pF}$		18	33	
		$V_{CC} = 6\text{V}$	$C_L = 50\text{pF}$		11	20	
			$C_L = 150\text{pF}$		15	28	
t_{en}	从 \overline{OE} (输入) 到 Y (输出)	$V_{CC} = 2\text{V}$	$C_L = 50\text{pF}$		75	150	ns
			$C_L = 150\text{pF}$		100	200	
		$V_{CC} = 4.5\text{V}$	$C_L = 50\text{pF}$		15	30	
			$C_L = 150\text{pF}$		20	40	
		$V_{CC} = 6\text{V}$	$C_L = 50\text{pF}$		13	26	
			$C_L = 150\text{pF}$		17	34	
t_{dis}	从 \overline{OE} (输入) 到 Y (输出)	$V_{CC} = 2\text{V}$	$C_L = 50\text{pF}$		75	150	ns
		$V_{CC} = 4.5\text{V}$	$C_L = 50\text{pF}$		15	30	
		$V_{CC} = 6\text{V}$	$C_L = 50\text{pF}$		13	26	
t_t	到 Y (输出)	$V_{CC} = 2\text{V}$	$C_L = 50\text{pF}$		28	60	ns
			$C_L = 150\text{pF}$		45	210	
		$V_{CC} = 4.5\text{V}$	$C_L = 50\text{pF}$		8	12	
			$C_L = 150\text{pF}$		17	42	
		$V_{CC} = 6\text{V}$	$C_L = 50\text{pF}$		6	10	
			$C_L = 150\text{pF}$		13	36	

5.10 开关特性 - $C_L = 50\text{pF}$

在建议的自然通风条件下的工作温度范围内测得 (除非另有说明; 请参阅图 6-1)

参数	测试条件		最小值	典型值	最大值	单位	
t_{pd}	从 A (输入) 到 Y (输出)	$V_{CC} = 2\text{V}$	$T_A = -55^\circ\text{C}$ 至 125°C		170	ns	
			$T_A = -40^\circ\text{C}$ 至 125°C		170		
			$T_A = -40^\circ\text{C}$ 至 85°C		145		
		$V_{CC} = 4.5\text{V}$	$T_A = -55^\circ\text{C}$ 至 125°C		34		34
			$T_A = -40^\circ\text{C}$ 至 125°C		34		
			$T_A = -40^\circ\text{C}$ 至 85°C		29		
		$V_{CC} = 6\text{V}$	$T_A = -55^\circ\text{C}$ 至 125°C		29		29
			$T_A = -40^\circ\text{C}$ 至 125°C		29		
			$T_A = -40^\circ\text{C}$ 至 85°C		25		

在建议的自然通风条件下的工作温度范围内测得 (除非另有说明; 请参阅图 6-1)

参数	测试条件		最小值	典型值	最大值	单位
t_{en}	从 \overline{OE} (输入) 到 Y (输出)	$V_{CC} = 2V$	$T_A = -55^\circ C$ 至 $125^\circ C$		225	ns
			$T_A = -40^\circ C$ 至 $125^\circ C$		225	
			$T_A = -40^\circ C$ 至 $85^\circ C$		190	
		$V_{CC} = 4.5V$	$T_A = -55^\circ C$ 至 $125^\circ C$		45	
			$T_A = -40^\circ C$ 至 $125^\circ C$		45	
			$T_A = -40^\circ C$ 至 $85^\circ C$		38	
		$V_{CC} = 6V$	$T_A = -55^\circ C$ 至 $125^\circ C$		38	
			$T_A = -40^\circ C$ 至 $125^\circ C$		38	
			$T_A = -40^\circ C$ 至 $85^\circ C$		32	
t_{dis}	从 \overline{OE} (输入) 到 Y (输出)	$V_{CC} = 2V$	$T_A = -55^\circ C$ 至 $125^\circ C$		225	ns
			$T_A = -40^\circ C$ 至 $125^\circ C$		225	
			$T_A = -40^\circ C$ 至 $85^\circ C$		190	
		$V_{CC} = 4.5V$	$T_A = -55^\circ C$ 至 $125^\circ C$		45	
			$T_A = -40^\circ C$ 至 $125^\circ C$		45	
			$T_A = -40^\circ C$ 至 $85^\circ C$		38	
		$V_{CC} = 6V$	$T_A = -55^\circ C$ 至 $125^\circ C$		38	
			$T_A = -40^\circ C$ 至 $125^\circ C$		38	
			$T_A = -40^\circ C$ 至 $85^\circ C$		32	

在建议的自然通风条件下的工作温度范围内测得 (除非另有说明; 请参阅图 6-1)

参数	测试条件		最小值	典型值	最大值	单位
t_t	到 Y (输出)	$V_{CC} = 2V$	$T_A = -55^{\circ}C$ 至 $125^{\circ}C$		90	ns
			$T_A = -40^{\circ}C$ 至 $125^{\circ}C$		90	
			$T_A = -40^{\circ}C$ 至 $85^{\circ}C$		75	
		$V_{CC} = 4.5V$	$T_A = -55^{\circ}C$ 至 $125^{\circ}C$		18	
			$T_A = -40^{\circ}C$ 至 $125^{\circ}C$		18	
			$T_A = -40^{\circ}C$ 至 $85^{\circ}C$		15	
		$V_{CC} = 6V$	$T_A = -55^{\circ}C$ 至 $125^{\circ}C$		15	
			$T_A = -40^{\circ}C$ 至 $125^{\circ}C$		15	
			$T_A = -40^{\circ}C$ 至 $85^{\circ}C$		13	

5.11 开关特性 - $C_L = 150pF$

在建议的自然通风条件下的工作温度范围内测得 (除非另有说明; 请参阅图 6-1)

参数	测试条件		最小值	典型值	最大值	单位
t_{pd}	从 A (输入) 到 Y (输出)	$V_{CC} = 2V$	$T_A = -55^{\circ}C$ 至 $125^{\circ}C$		245	ns
			$T_A = -40^{\circ}C$ 至 $125^{\circ}C$		245	
			$T_A = -40^{\circ}C$ 至 $85^{\circ}C$		210	
		$V_{CC} = 4.5V$	$T_A = -55^{\circ}C$ 至 $125^{\circ}C$		49	
			$T_A = -40^{\circ}C$ 至 $125^{\circ}C$		49	
			$T_A = -40^{\circ}C$ 至 $85^{\circ}C$		42	
		$V_{CC} = 6V$	$T_A = -55^{\circ}C$ 至 $125^{\circ}C$		42	
			$T_A = -40^{\circ}C$ 至 $125^{\circ}C$		42	
			$T_A = -40^{\circ}C$ 至 $85^{\circ}C$		35	

在建议的自然通风条件下的工作温度范围内测得 (除非另有说明; 请参阅图 6-1)

参数	测试条件		最小值	典型值	最大值	单位
t_{en}	从 \overline{OE} (输入) 到 Y (输出)	$V_{CC} = 2V$	$T_A = -55^\circ\text{C}$ 至 125°C		300	ns
			$T_A = -40^\circ\text{C}$ 至 125°C		300	
			$T_A = -40^\circ\text{C}$ 至 85°C		250	
		$V_{CC} = 4.5V$	$T_A = -55^\circ\text{C}$ 至 125°C		60	
			$T_A = -40^\circ\text{C}$ 至 125°C		60	
			$T_A = -40^\circ\text{C}$ 至 85°C		50	
		$V_{CC} = 6V$	$T_A = -55^\circ\text{C}$ 至 125°C		51	
			$T_A = -40^\circ\text{C}$ 至 125°C		51	
			$T_A = -40^\circ\text{C}$ 至 85°C		43	
t_t	到 Y (输出)	$V_{CC} = 2V$	$T_A = -55^\circ\text{C}$ 至 125°C		315	ns
			$T_A = -40^\circ\text{C}$ 至 125°C		315	
			$T_A = -40^\circ\text{C}$ 至 85°C		265	
		$V_{CC} = 4.5V$	$T_A = -55^\circ\text{C}$ 至 125°C		63	
			$T_A = -40^\circ\text{C}$ 至 125°C		63	
			$T_A = -40^\circ\text{C}$ 至 85°C		53	
		$V_{CC} = 6V$	$T_A = -55^\circ\text{C}$ 至 125°C		53	
			$T_A = -40^\circ\text{C}$ 至 125°C		53	
			$T_A = -40^\circ\text{C}$ 至 85°C		45	

5.12 典型特性



图 5-1. 传播延迟

6 参数测量信息



图 6-1. 负载电路

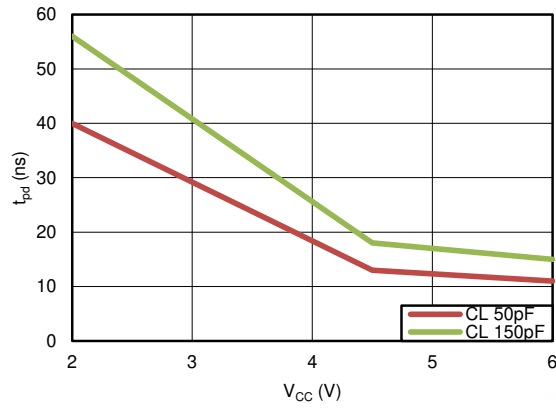

图 6-2. 传播延迟和输出转换时间

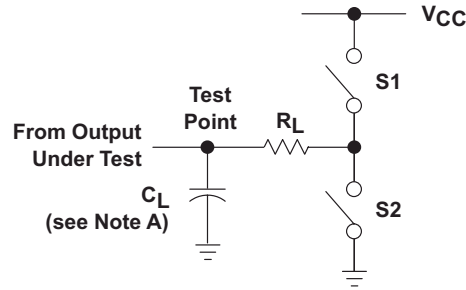

图 6-3. 输入上升和下降时间

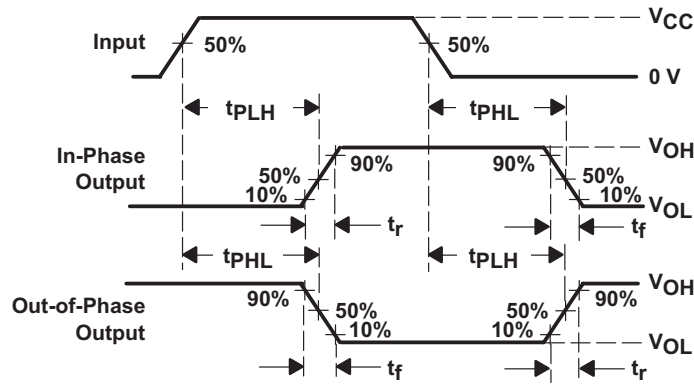

图 6-4. 三态输出的启用和禁用时间

备注

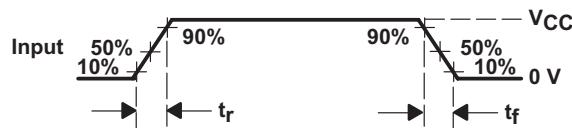
注意：

- A. C_L 包括探头与测试夹具电容。
- B. 波形 1 用于具有内部条件的输出，使得输出为低电平，除非被输出控制禁用。波形 2 用于具有内部条件的输出，使得输出为高电平，除非被输出控制禁用。
- C. 任意选择波形之间的相位关系。所有输入脉冲均由具有以下特性的发生器提供： $PRR \leq 1\text{MHz}$ ， $Z_O = 50\ \Omega$ ， $t_r = 6\text{ns}$ ， $t_f = 6\text{ns}$ 。
- D. 一次测量一个输出，每次测量进行一次输入转换。
- E. t_{PLZ} 和 t_{PHZ} 与 t_{dis} 一样。
- F. t_{pZL} 和 t_{pZH} 与 t_{en} 一样。
- G. t_{PLH} 和 t_{PHL} 与 t_{pd} 一样。

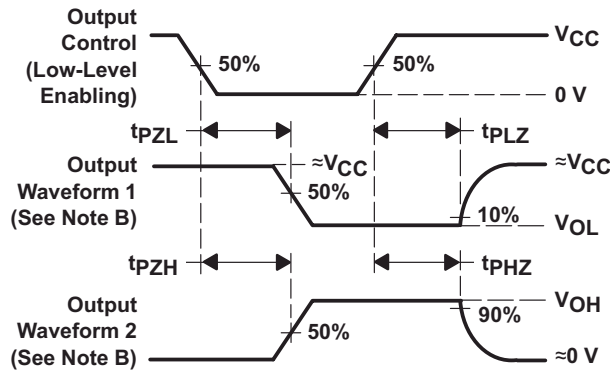
表 6-1. 开关信息表

参数		RL	CL	S1	S2
t_{en}	t_{pZH}	1k Ω	50pF 或 150pF	开路	闭合
	t_{pZL}	1k Ω	50pF 或 150pF	闭合	开路
t_{dis}	t_{PHZ}	1k Ω	50pF	开路	闭合
	t_{PLZ}	1k Ω	50pF	闭合	开路
t_{pd} 或 t_t		—	50pF 或 150pF	开路	开路

7 详细说明

7.1 概述

SNx4HC244 包含 8 个独立的高速 CMOS 缓冲器，配置为两个具有三态输出的 4 位缓冲器/线路驱动器。

每个缓冲器均可执行布尔逻辑函数 $xY_n = xA_n$ ，其中 x 为存储体编号， n 为通道编号。

每个输出使能 ($x\overline{OE}$) 控制四个缓冲器。当 $x\overline{OE}$ 引脚处于低电平状态时，存储体 x 中所有缓冲器的输出将被启用。当 $x\overline{OE}$ 引脚处于高电平状态时，存储体 x 中所有缓冲器的输出将被禁用。所有被禁用的输出将置于高阻抗状态。

为了在上电或断电期间将器件置于高阻抗状态，需将两个 \overline{OE} 引脚通过一个上拉电阻连接至 V_{CC} ；电阻的最小值由驱动器的灌电流能力和电气特性表中定义的引脚漏电流决定。

7.2 功能方框图



图 7-1. 逻辑图 (正逻辑)

7.3 特性说明

7.3.1 标准 CMOS 输入

此器件包括标准 CMOS 输入。标准 CMOS 输入为高阻抗，通常建模为与输入电容并联的电阻器，如电气特性中所示。最坏情况下的电阻使用绝对最大额定值中给出的最大输入电压和电气特性中给出的最大输入泄漏电流，根据欧姆定律 ($R = V \div I$) 计算得出。

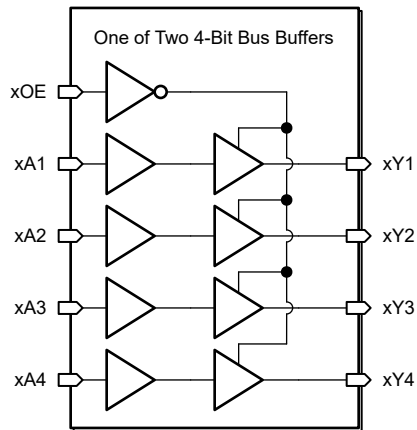
标准 CMOS 输入要求输入信号在有效逻辑状态之间快速转换，如建议运行条件表中的输入转换时间或速率所定义。不符合此规范将导致功耗过大并可能导致振荡。更多详细信息，请参阅 CMOS 输入缓慢或悬空的影响。

在运行期间，任何时候都不要让标准 CMOS 输入悬空。未使用的输入必须在 V_{CC} 或 GND 端接。如果系统不会一直主动驱动输入，则可以添加上拉或下拉电阻器，以在这些时间段提供有效的输入电压。电阻值将取决于多种因素；但建议使用 $10k\Omega$ 电阻器，这通常可以满足所有要求。

7.4 器件功能模式

表 7-1 列出了 SNx4HC244 的功能模式。

表 7-1. 功能表

输入 ⁽¹⁾		输出
OE	A	Y
L	L	L
L	H	H
H	X	Z

(1) H = 高压电平, L = 低压电平, X = 无关, Z = 高阻抗状态

8 应用和实施

备注

以下应用部分中的信息不属于 TI 器件规格的范围，TI 不担保其准确性和完整性。TI 的客户应负责确定器件是否适用于其应用。客户应验证并测试其设计，以确保系统功能。

8.1 应用信息

SN74HC244 是一款低驱动 CMOS 器件，可用于需要考虑输出驱动或布线长度的多种总线接口类型应用。

8.2 典型应用

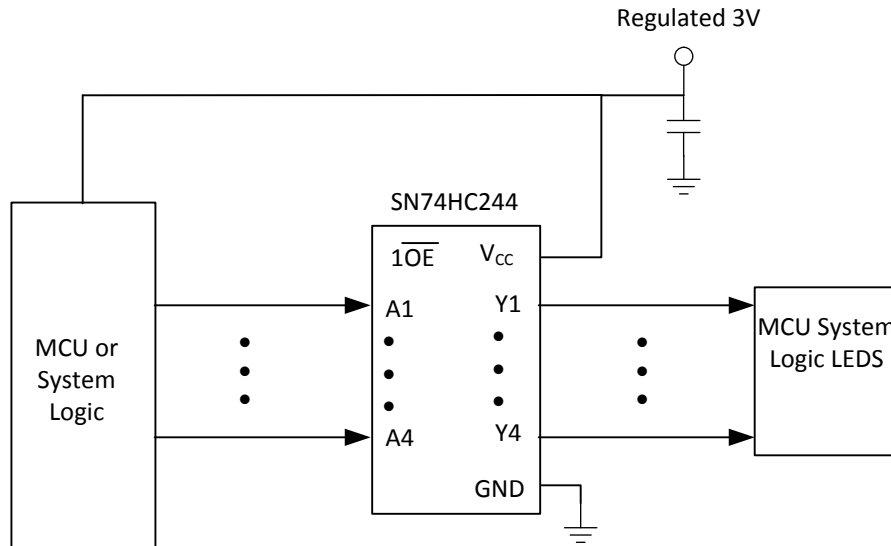

Copyright © 2016, Texas Instruments Incorporated

图 8-1. SN74HC244 应用原理图

8.2.1 设计要求

此器件采用 CMOS 技术并具有平衡输出驱动。注意避免总线争用，因为它可以驱动超过最大限值的电流。高驱动也会在轻负载时产生快速边缘，因此应考虑布线和负载条件以防止振铃。

8.2.2 详细设计过程

1. 建议的输入条件：

- 有关上升时间和下降时间规范，请参阅 [节 5.3](#) 表中的 $\Delta t / \Delta V$ 。
- 有关指定的高电平和低电平，请参阅 [节 5.3](#) 中的 V_{IH} 和 V_{IL} 。

2. 建议的输出条件：

- 每路输出的负载电流不应超过最大值 I_O ，且不应超过该器件通过 V_{CC} 的持续电流或 GND 总电流。这些示例位于：[节 5.1](#)。
- 输出不应被拉至高于 V_{CC} 。

8.2.3 应用曲线



图 8-2. 启用时间

8.3 电源相关建议

电源可以是 *建议运行条件* 中最小和最大电源电压额定值之间的任何电压。每个 V_{CC} 端子均应具有良好的旁路电容器，以防止功率干扰。

建议为该器件使用 $0.1\ \mu\text{F}$ 电容器。可以并联多个旁路电容器以抑制不同的噪声频率。 $0.1\ \mu\text{F}$ 和 $1\ \mu\text{F}$ 电容器通常并联使用。为了获得最佳效果，旁路电容器必须尽可能靠近电源端子安装。

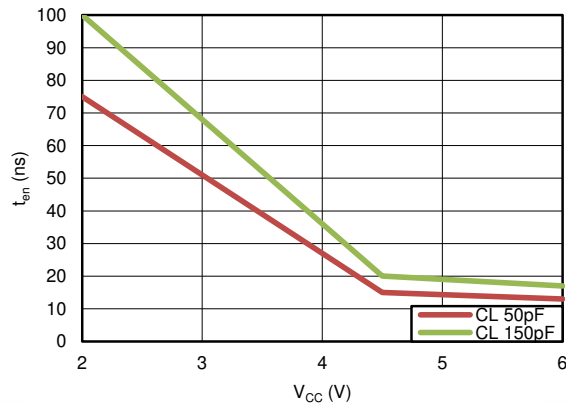
8.4 布局指南

- 旁路电容器的放置
 - 靠近器件的正电源端子放置
 - 提供电气短接地返回路径
 - 使用宽布线以最大限度减小阻抗
 - 尽可能将器件、电容器和布线保持在电路板的同一面
- 信号布线几何形状
 - 8mil 至 12mil 布线宽度
 - 布线长度小于 12cm 可最大限度减轻传输线路影响
 - 避免信号布线出现 90° 角
 - 在信号布线下方使用不间断的接地平面
 - 通过接地对信号布线周围的区域进行泛洪填充
 - 并行布线之间必须至少间隔 3 倍电介质厚度
 - 对于长度超过 12cm 的布线
 - 使用阻抗受控的布线
 - 在输出端附近使用串联阻尼电阻进行源端接
 - 避免分支；对必须单独分支的每条信号进行缓冲

8.4.1 布局示例



图 8-3. 可改善信号完整性的布线转角示例



图 8-4. TSSOP 和类似封装的旁路电容器放置示例

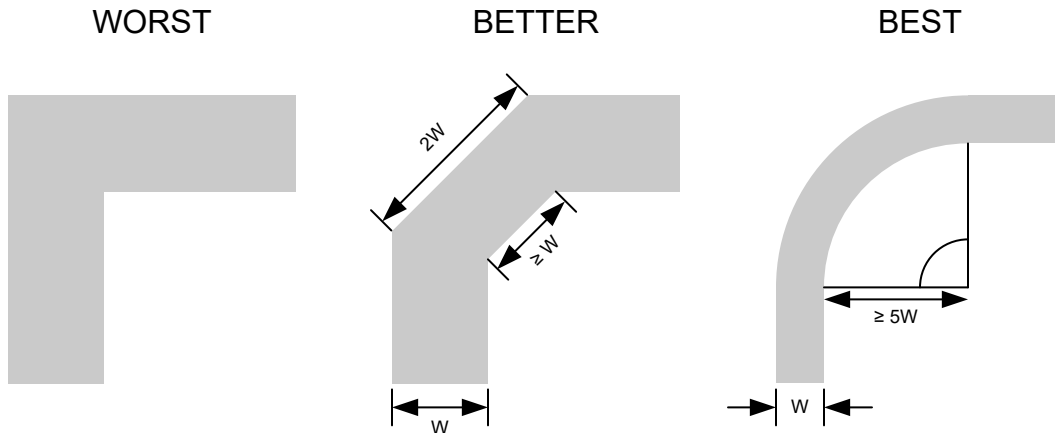

图 8-5. WQFN 和类似封装的旁路电容器放置示例

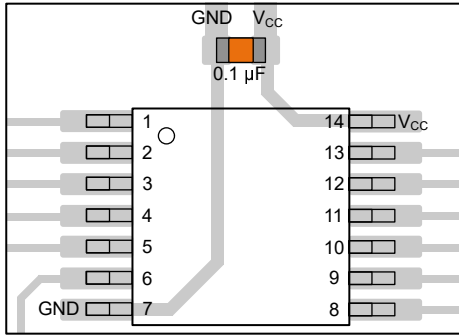

图 8-6. SOT、SC70 和类似封装的旁路电容器放置示例

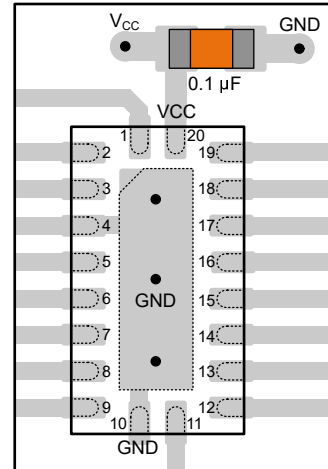

图 8-7. 可改善信号完整性的阻尼电阻放置示例

9 器件和文档支持

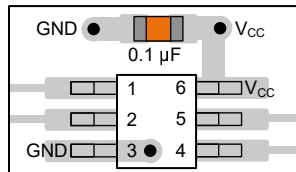
9.1 文档支持

9.1.1 文档支持

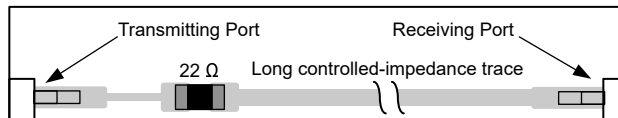
- 德州仪器 (TI), [CMOS 输入缓慢或悬空的影响 应用手册](#)
- 德州仪器 (TI), [半导体和 IC 封装热指标 应用手册](#)

9.2 接收文档更新通知

要接收文档更新通知, 请导航至 [ti.com](#) 上的器件产品文件夹。点击 [通知](#) 进行注册, 即可每周接收产品信息更改摘要。有关更改的详细信息, 请查看任何已修订文档中包含的修订历史记录。

9.3 支持资源

[TI E2E™ 中文支持论坛](#) 是工程师的重要参考资料, 可直接从专家处获得快速、经过验证的解答和设计帮助。搜索现有解答或提出自己的问题, 获得所需的快速设计帮助。

链接的内容由各个贡献者“按原样”提供。这些内容并不构成 TI 技术规范, 并且不一定反映 TI 的观点; 请参阅 TI 的 [使用条款](#)。

9.4 商标

TI E2E™ is a trademark of Texas Instruments.

所有商标均为其各自所有者的财产。

9.5 静电放电警告



静电放电 (ESD) 会损坏这个集成电路。德州仪器 (TI) 建议通过适当的预防措施处理所有集成电路。如果不遵守正确的处理和安装程序, 可能会损坏集成电路。

ESD 的损坏小至导致微小的性能降级, 大至整个器件故障。精密的集成电路可能更容易受到损坏, 这是因为非常细微的参数更改都可能会导致器件与其发布的规格不相符。

9.6 术语表

[TI 术语表](#) 本术语表列出并解释了术语、首字母缩略词和定义。

10 修订历史记录

注: 以前版本的页码可能与当前版本的页码不同

Changes from Revision H (February 2025) to Revision I (January 2026) **Page**

- 将 SN74HC244 工作温度从 85°C 更新为 125°C..... **4**

Changes from Revision G (January 2025) to Revision H (February 2025) **Page**

- 更新了 [电气特性表](#)、[建议运行条件表](#) 和 [开关特性表](#) 中的 SN74HC244 值..... **1**

11 机械、封装和可订购信息

以下页面包含机械、封装和可订购信息。这些信息是指定器件可用的最新数据。数据如有变更, 恕不另行通知, 且不会对此文档进行修订。有关此数据表的浏览器版本, 请查阅左侧的导航栏。

PACKAGING INFORMATION

Orderable part number	Status (1)	Material type (2)	Package Pins	Package qty Carrier	RoHS (3)	Lead finish/ Ball material (4)	MSL rating/ Peak reflow (5)	Op temp (°C)	Part marking (6)
5962-8409601VRA	Active	Production	CDIP (J) 20	20 TUBE	No	SNPB	N/A for Pkg Type	-55 to 125	5962-8409601VRA A SNV54HC244J
5962-8409601VRA.A	Active	Production	CDIP (J) 20	20 TUBE	No	SNPB	N/A for Pkg Type	-55 to 125	5962-8409601VRA A SNV54HC244J
5962-8409601VSA	Active	Production	CFP (W) 20	25 TUBE	No	SNPB	N/A for Pkg Type	-55 to 125	5962-8409601VSA A SNV54HC244W
5962-8409601VSA.A	Active	Production	CFP (W) 20	25 TUBE	No	SNPB	N/A for Pkg Type	-55 to 125	5962-8409601VSA A SNV54HC244W
84096012A	Active	Production	LCCC (FK) 20	55 TUBE	No	SNPB	N/A for Pkg Type	-55 to 125	84096012A SNJ54HC 244FK
8409601RA	Active	Production	CDIP (J) 20	20 TUBE	No	SNPB	N/A for Pkg Type	-55 to 125	8409601RA SNJ54HC244J
8409601SA	Active	Production	CFP (W) 20	25 TUBE	No	SNPB	N/A for Pkg Type	-55 to 125	8409601SA SNJ54HC244W
JM38510/65705B2A	Active	Production	LCCC (FK) 20	55 TUBE	No	SNPB	N/A for Pkg Type	-55 to 125	JM38510/ 65705B2A
JM38510/65705B2A.A	Active	Production	LCCC (FK) 20	55 TUBE	No	SNPB	N/A for Pkg Type	-55 to 125	JM38510/ 65705B2A
JM38510/65705BRA	Active	Production	CDIP (J) 20	20 TUBE	No	SNPB	N/A for Pkg Type	-55 to 125	JM38510/ 65705BRA
JM38510/65705BRA.A	Active	Production	CDIP (J) 20	20 TUBE	No	SNPB	N/A for Pkg Type	-55 to 125	JM38510/ 65705BRA
JM38510/65705BSA	Active	Production	CFP (W) 20	25 TUBE	No	SNPB	N/A for Pkg Type	-55 to 125	JM38510/ 65705BSA
JM38510/65705BSA.A	Active	Production	CFP (W) 20	25 TUBE	No	SNPB	N/A for Pkg Type	-55 to 125	JM38510/ 65705BSA
M38510/65705B2A	Active	Production	LCCC (FK) 20	55 TUBE	No	SNPB	N/A for Pkg Type	-55 to 125	JM38510/ 65705B2A

Orderable part number	Status (1)	Material type (2)	Package Pins	Package qty Carrier	RoHS (3)	Lead finish/ Ball material (4)	MSL rating/ Peak reflow (5)	Op temp (°C)	Part marking (6)
M38510/65705BRA	Active	Production	CDIP (J) 20	20 TUBE	No	SNPB	N/A for Pkg Type	-55 to 125	JM38510/ 65705BRA
M38510/65705BSA	Active	Production	CFP (W) 20	25 TUBE	No	SNPB	N/A for Pkg Type	-55 to 125	JM38510/ 65705BSA
SN54HC244J	Active	Production	CDIP (J) 20	20 TUBE	No	SNPB	N/A for Pkg Type	-55 to 125	SN54HC244J
SN54HC244J.A	Active	Production	CDIP (J) 20	20 TUBE	No	SNPB	N/A for Pkg Type	-55 to 125	SN54HC244J
SN74HC244APWR	Active	Production	TSSOP (PW) 20	2000 LARGE T&R	Yes	NIPDAU	Level-1-260C-UNLIM	-40 to 85	HC244A
SN74HC244APWR.A	Active	Production	TSSOP (PW) 20	2000 LARGE T&R	Yes	NIPDAU	Level-1-260C-UNLIM	-40 to 85	HC244A
SN74HC244DBR	Active	Production	SSOP (DB) 20	2000 LARGE T&R	Yes	NIPDAU	Level-1-260C-UNLIM	-40 to 85	HC244
SN74HC244DBR.A	Active	Production	SSOP (DB) 20	2000 LARGE T&R	Yes	NIPDAU	Level-1-260C-UNLIM	-40 to 85	HC244
SN74HC244DWR	Active	Production	SOIC (DW) 20	2000 LARGE T&R	Yes	NIPDAU	Level-1-260C-UNLIM	-40 to 85	HC244
SN74HC244DWR.A	Active	Production	SOIC (DW) 20	2000 LARGE T&R	Yes	NIPDAU	Level-1-260C-UNLIM	-40 to 85	HC244
SN74HC244DWRE4	Active	Production	SOIC (DW) 20	2000 LARGE T&R	Yes	NIPDAU	Level-1-260C-UNLIM	-40 to 85	HC244
SN74HC244DWRG4	Active	Production	SOIC (DW) 20	2000 LARGE T&R	Yes	NIPDAU	Level-1-260C-UNLIM	-40 to 85	HC244
SN74HC244DWRG4.A	Active	Production	SOIC (DW) 20	2000 LARGE T&R	Yes	NIPDAU	Level-1-260C-UNLIM	-40 to 85	HC244
SN74HC244N	Active	Production	PDIP (N) 20	20 TUBE	Yes	NIPDAU	N/A for Pkg Type	-40 to 85	SN74HC244N
SN74HC244N.A	Active	Production	PDIP (N) 20	20 TUBE	Yes	NIPDAU	N/A for Pkg Type	-40 to 85	SN74HC244N
SN74HC244NE4	Active	Production	PDIP (N) 20	20 TUBE	Yes	NIPDAU	N/A for Pkg Type	-40 to 85	SN74HC244N
SN74HC244NSR	Active	Production	SOP (NS) 20	2000 LARGE T&R	Yes	NIPDAU	Level-1-260C-UNLIM	-40 to 85	HC244
SN74HC244NSR.A	Active	Production	SOP (NS) 20	2000 LARGE T&R	Yes	NIPDAU	Level-1-260C-UNLIM	-40 to 85	HC244
SN74HC244NSRG4	Active	Production	SOP (NS) 20	2000 LARGE T&R	Yes	NIPDAU	Level-1-260C-UNLIM	-40 to 85	HC244
SN74HC244PW	Obsolete	Production	TSSOP (PW) 20	-	-	Call TI	Call TI	-40 to 85	HC244
SN74HC244PWR	Active	Production	TSSOP (PW) 20	2000 LARGE T&R	Yes	NIPDAU	Level-1-260C-UNLIM	-40 to 85	HC244
SN74HC244PWR.A	Active	Production	TSSOP (PW) 20	2000 LARGE T&R	Yes	NIPDAU	Level-1-260C-UNLIM	-40 to 85	HC244
SN74HC244PWRE4	Active	Production	TSSOP (PW) 20	2000 LARGE T&R	Yes	NIPDAU	Level-1-260C-UNLIM	-40 to 85	HC244
SN74HC244PWRG4	Active	Production	TSSOP (PW) 20	2000 LARGE T&R	Yes	NIPDAU	Level-1-260C-UNLIM	-40 to 85	HC244
SN74HC244PWT	Obsolete	Production	TSSOP (PW) 20	-	-	Call TI	Call TI	-40 to 85	HC244
SN74HC244QDWRG4Q1	Active	Production	SOIC (DW) 20	2000 LARGE T&R	Yes	NIPDAU	Level-1-260C-UNLIM	-	HC244Q
SN74HC244QDWRG4Q1.A	Active	Production	SOIC (DW) 20	2000 LARGE T&R	Yes	NIPDAU	Level-1-260C-UNLIM	-40 to 85	HC244Q
SNJ54HC244FK	Active	Production	LCCC (FK) 20	55 TUBE	No	SNPB	N/A for Pkg Type	-55 to 125	84096012A SNJ54HC 244FK

Orderable part number	Status (1)	Material type (2)	Package Pins	Package qty Carrier	RoHS (3)	Lead finish/ Ball material (4)	MSL rating/ Peak reflow (5)	Op temp (°C)	Part marking (6)
SNJ54HC244FK.A	Active	Production	LCCC (FK) 20	55 TUBE	No	SNPB	N/A for Pkg Type	-55 to 125	84096012A SNJ54HC 244FK
SNJ54HC244J	Active	Production	CDIP (J) 20	20 TUBE	No	SNPB	N/A for Pkg Type	-55 to 125	8409601RA SNJ54HC244J
SNJ54HC244J.A	Active	Production	CDIP (J) 20	20 TUBE	No	SNPB	N/A for Pkg Type	-55 to 125	8409601RA SNJ54HC244J
SNJ54HC244W	Active	Production	CFP (W) 20	25 TUBE	No	SNPB	N/A for Pkg Type	-55 to 125	8409601SA SNJ54HC244W
SNJ54HC244W.A	Active	Production	CFP (W) 20	25 TUBE	No	SNPB	N/A for Pkg Type	-55 to 125	8409601SA SNJ54HC244W

(1) **Status:** For more details on status, see our [product life cycle](#).

(2) **Material type:** When designated, preproduction parts are prototypes/experimental devices, and are not yet approved or released for full production. Testing and final process, including without limitation quality assurance, reliability performance testing, and/or process qualification, may not yet be complete, and this item is subject to further changes or possible discontinuation. If available for ordering, purchases will be subject to an additional waiver at checkout, and are intended for early internal evaluation purposes only. These items are sold without warranties of any kind.

(3) **RoHS values:** Yes, No, RoHS Exempt. See the [TI RoHS Statement](#) for additional information and value definition.

(4) **Lead finish/Ball material:** Parts may have multiple material finish options. Finish options are separated by a vertical ruled line. Lead finish/Ball material values may wrap to two lines if the finish value exceeds the maximum column width.

(5) **MSL rating/Peak reflow:** The moisture sensitivity level ratings and peak solder (reflow) temperatures. In the event that a part has multiple moisture sensitivity ratings, only the lowest level per JEDEC standards is shown. Refer to the shipping label for the actual reflow temperature that will be used to mount the part to the printed circuit board.

(6) **Part marking:** There may be an additional marking, which relates to the logo, the lot trace code information, or the environmental category of the part.

Multiple part markings will be inside parentheses. Only one part marking contained in parentheses and separated by a "~" will appear on a part. If a line is indented then it is a continuation of the previous line and the two combined represent the entire part marking for that device.

Important Information and Disclaimer: The information provided on this page represents TI's knowledge and belief as of the date that it is provided. TI bases its knowledge and belief on information provided by third parties, and makes no representation or warranty as to the accuracy of such information. Efforts are underway to better integrate information from third parties. TI has taken and continues to take reasonable steps to provide representative and accurate information but may not have conducted destructive testing or chemical analysis on incoming materials and chemicals. TI and TI suppliers consider certain information to be proprietary, and thus CAS numbers and other limited information may not be available for release.

In no event shall TI's liability arising out of such information exceed the total purchase price of the TI part(s) at issue in this document sold by TI to Customer on an annual basis.

OTHER QUALIFIED VERSIONS OF SN54HC244, SN54HC244-SP, SN74HC244 :

- Catalog : [SN74HC244](#), [SN54HC244](#)

- Automotive : [SN74HC244-Q1](#), [SN74HC244-Q1](#)

- Enhanced Product : [SN74HC244-EP](#), [SN74HC244-EP](#)

- Military : [SN54HC244](#)

- Space : [SN54HC244-SP](#)

NOTE: Qualified Version Definitions:

- Catalog - TI's standard catalog product

- Automotive - Q100 devices qualified for high-reliability automotive applications targeting zero defects

- Enhanced Product - Supports Defense, Aerospace and Medical Applications

- Military - QML certified for Military and Defense Applications

- Space - Radiation tolerant, ceramic packaging and qualified for use in Space-based application

TAPE AND REEL INFORMATION

QUADRANT ASSIGNMENTS FOR PIN 1 ORIENTATION IN TAPE



*All dimensions are nominal

Device	Package Type	Package Drawing	Pins	SPQ	Reel Diameter (mm)	Reel Width W1 (mm)	A0 (mm)	B0 (mm)	K0 (mm)	P1 (mm)	W (mm)	Pin1 Quadrant
SN74HC244APWR	TSSOP	PW	20	2000	330.0	16.4	6.95	7.0	1.4	8.0	16.0	Q1
SN74HC244DBR	SSOP	DB	20	2000	330.0	16.4	8.2	7.5	2.5	12.0	16.0	Q1
SN74HC244DWR	SOIC	DW	20	2000	330.0	24.4	10.9	13.3	2.7	12.0	24.0	Q1
SN74HC244DWR	SOIC	DW	20	2000	330.0	24.4	10.8	13.3	2.7	12.0	24.0	Q1
SN74HC244DWRG4	SOIC	DW	20	2000	330.0	24.4	10.8	13.3	2.7	12.0	24.0	Q1
SN74HC244NSR	SOP	NS	20	2000	330.0	24.4	8.4	13.0	2.5	12.0	24.0	Q1
SN74HC244PWR	TSSOP	PW	20	2000	330.0	16.4	6.95	7.0	1.4	8.0	16.0	Q1
SN74HC244QDWRG4Q1	SOIC	DW	20	2000	330.0	24.4	10.8	13.3	2.7	12.0	24.0	Q1

TAPE AND REEL BOX DIMENSIONS

*All dimensions are nominal

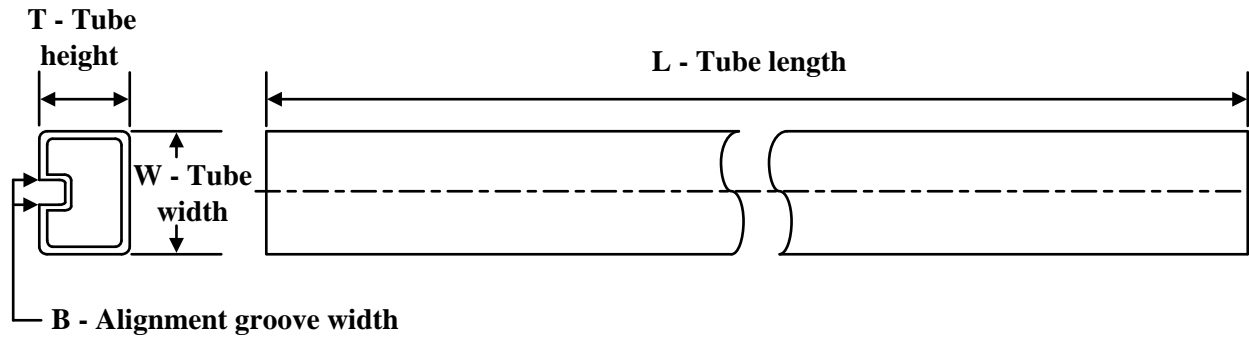
Device	Package Type	Package Drawing	Pins	SPQ	Length (mm)	Width (mm)	Height (mm)
SN74HC244APWR	TSSOP	PW	20	2000	353.0	353.0	32.0
SN74HC244DBR	SSOP	DB	20	2000	353.0	353.0	32.0
SN74HC244DWR	SOIC	DW	20	2000	356.0	356.0	45.0
SN74HC244DWR	SOIC	DW	20	2000	356.0	356.0	45.0
SN74HC244DWRG4	SOIC	DW	20	2000	356.0	356.0	45.0
SN74HC244NSR	SOP	NS	20	2000	356.0	356.0	45.0
SN74HC244PWR	TSSOP	PW	20	2000	353.0	353.0	32.0
SN74HC244QDWRG4Q1	SOIC	DW	20	2000	356.0	356.0	45.0

TUBE

*All dimensions are nominal

Device	Package Name	Package Type	Pins	SPQ	L (mm)	W (mm)	T (μm)	B (mm)
5962-8409601VSA	W	CFP	20	25	506.98	26.16	6220	NA
5962-8409601VSA.A	W	CFP	20	25	506.98	26.16	6220	NA
84096012A	FK	LCCC	20	55	506.98	12.06	2030	NA
8409601SA	W	CFP	20	25	506.98	26.16	6220	NA
JM38510/65705B2A	FK	LCCC	20	55	506.98	12.06	2030	NA
JM38510/65705B2A.A	FK	LCCC	20	55	506.98	12.06	2030	NA
JM38510/65705BSA	W	CFP	20	25	506.98	26.16	6220	NA
JM38510/65705BSA.A	W	CFP	20	25	506.98	26.16	6220	NA
M38510/65705B2A	FK	LCCC	20	55	506.98	12.06	2030	NA
M38510/65705BSA	W	CFP	20	25	506.98	26.16	6220	NA
SN74HC244N	N	PDIP	20	20	506	13.97	11230	4.32
SN74HC244N.A	N	PDIP	20	20	506	13.97	11230	4.32
SN74HC244NE4	N	PDIP	20	20	506	13.97	11230	4.32
SNJ54HC244FK	FK	LCCC	20	55	506.98	12.06	2030	NA
SNJ54HC244FK.A	FK	LCCC	20	55	506.98	12.06	2030	NA
SNJ54HC244W	W	CFP	20	25	506.98	26.16	6220	NA
SNJ54HC244W.A	W	CFP	20	25	506.98	26.16	6220	NA

W (R-GDFP-F20)

CERAMIC DUAL FLATPACK



- NOTES:
- A. All linear dimensions are in inches (millimeters).
 - B. This drawing is subject to change without notice.
 - C. This package can be hermetically sealed with a ceramic lid using glass frit.
 - D. Index point is provided on cap for terminal identification only.
 - E. Falls within Mil-Std 1835 GDFP2-F20

PW0020A



PACKAGE OUTLINE

TSSOP - 1.2 mm max height

SMALL OUTLINE PACKAGE



4220206/A 02/2017

NOTES:

1. All linear dimensions are in millimeters. Any dimensions in parenthesis are for reference only. Dimensioning and tolerancing per ASME Y14.5M.
2. This drawing is subject to change without notice.
3. This dimension does not include mold flash, protrusions, or gate burrs. Mold flash, protrusions, or gate burrs shall not exceed 0.15 mm per side.
4. This dimension does not include interlead flash. Interlead flash shall not exceed 0.25 mm per side.
5. Reference JEDEC registration MO-153.

EXAMPLE BOARD LAYOUT

PW0020A

TSSOP - 1.2 mm max height

SMALL OUTLINE PACKAGE



LAND PATTERN EXAMPLE
EXPOSED METAL SHOWN
SCALE: 10X



SOLDER MASK DETAILS

4220206/A 02/2017

NOTES: (continued)

- 6. Publication IPC-7351 may have alternate designs.
- 7. Solder mask tolerances between and around signal pads can vary based on board fabrication site.

EXAMPLE STENCIL DESIGN

PW0020A

TSSOP - 1.2 mm max height

SMALL OUTLINE PACKAGE



SOLDER PASTE EXAMPLE
BASED ON 0.125 mm THICK STENCIL
SCALE: 10X

4220206/A 02/2017

NOTES: (continued)

8. Laser cutting apertures with trapezoidal walls and rounded corners may offer better paste release. IPC-7525 may have alternate design recommendations.
9. Board assembly site may have different recommendations for stencil design.

DB0020A



PACKAGE OUTLINE

SSOP - 2 mm max height

SMALL OUTLINE PACKAGE



4214851/B 08/2019

NOTES:

1. All linear dimensions are in millimeters. Any dimensions in parenthesis are for reference only. Dimensioning and tolerancing per ASME Y14.5M.
2. This drawing is subject to change without notice.
3. This dimension does not include mold flash, protrusions, or gate burrs. Mold flash, protrusions, or gate burrs shall not exceed 0.15 mm per side.
4. This dimension does not include interlead flash. Interlead flash shall not exceed 0.25 mm per side.
5. Reference JEDEC registration MO-150.

EXAMPLE BOARD LAYOUT

DB0020A

SSOP - 2 mm max height

SMALL OUTLINE PACKAGE



LAND PATTERN EXAMPLE
EXPOSED METAL SHOWN
SCALE: 10X



4214851/B 08/2019

NOTES: (continued)

- 6. Publication IPC-7351 may have alternate designs.
- 7. Solder mask tolerances between and around signal pads can vary based on board fabrication site.

EXAMPLE STENCIL DESIGN

DB0020A

SSOP - 2 mm max height

SMALL OUTLINE PACKAGE



SOLDER PASTE EXAMPLE
BASED ON 0.125 mm THICK STENCIL
SCALE: 10X

4214851/B 08/2019

NOTES: (continued)

8. Laser cutting apertures with trapezoidal walls and rounded corners may offer better paste release. IPC-7525 may have alternate design recommendations.
9. Board assembly site may have different recommendations for stencil design.

MECHANICAL DATA

NS (R-PDSO-G**)

PLASTIC SMALL-OUTLINE PACKAGE

14-PINS SHOWN



- NOTES:
- A. All linear dimensions are in millimeters.
 - B. This drawing is subject to change without notice.
 - C. Body dimensions do not include mold flash or protrusion, not to exceed 0,15.

J (R-GDIP-T**)

14 LEADS SHOWN

CERAMIC DUAL IN-LINE PACKAGE



DIM \ PINS **	14	16	18	20
A	0.300 (7,62) BSC	0.300 (7,62) BSC	0.300 (7,62) BSC	0.300 (7,62) BSC
B MAX	0.785 (19,94)	.840 (21,34)	0.960 (24,38)	1.060 (26,92)
B MIN	—	—	—	—
C MAX	0.300 (7,62)	0.300 (7,62)	0.310 (7,87)	0.300 (7,62)
C MIN	0.245 (6,22)	0.245 (6,22)	0.220 (5,59)	0.245 (6,22)



4040083/F 03/03

- NOTES:
- A. All linear dimensions are in inches (millimeters).
 - B. This drawing is subject to change without notice.
 - C. This package is hermetically sealed with a ceramic lid using glass frit.
 - D. Index point is provided on cap for terminal identification only on press ceramic glass frit seal only.
 - E. Falls within MIL STD 1835 GDIP1-T14, GDIP1-T16, GDIP1-T18 and GDIP1-T20.

N (R-PDIP-T**)

PLASTIC DUAL-IN-LINE PACKAGE

16 PINS SHOWN

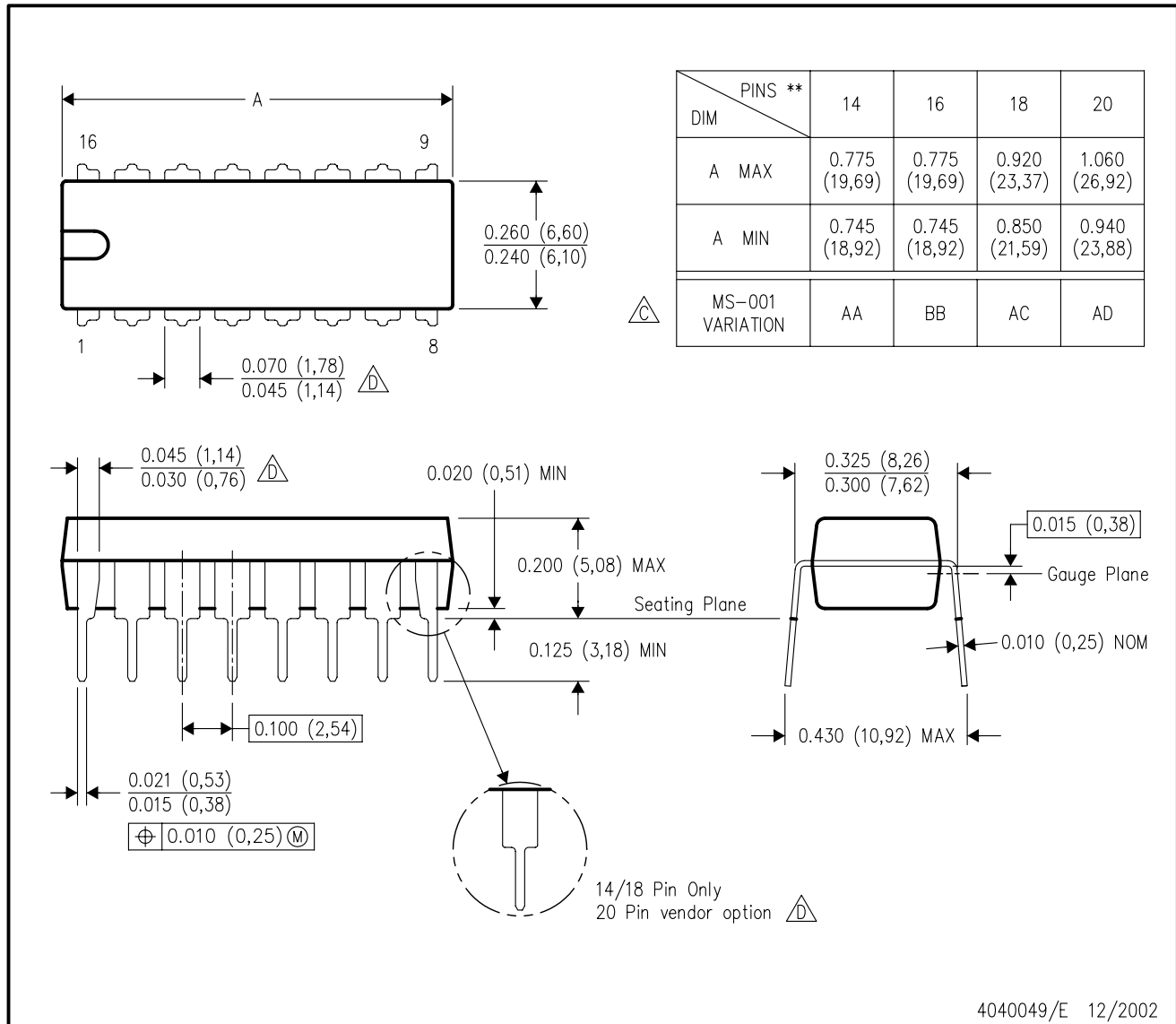

- NOTES:
- A. All linear dimensions are in inches (millimeters).
 - B. This drawing is subject to change without notice.
 - Falls within JEDEC MS-001, except 18 and 20 pin minimum body length (Dim A).
 - The 20 pin end lead shoulder width is a vendor option, either half or full width.

DW0020A



PACKAGE OUTLINE

SOIC - 2.65 mm max height

SOIC

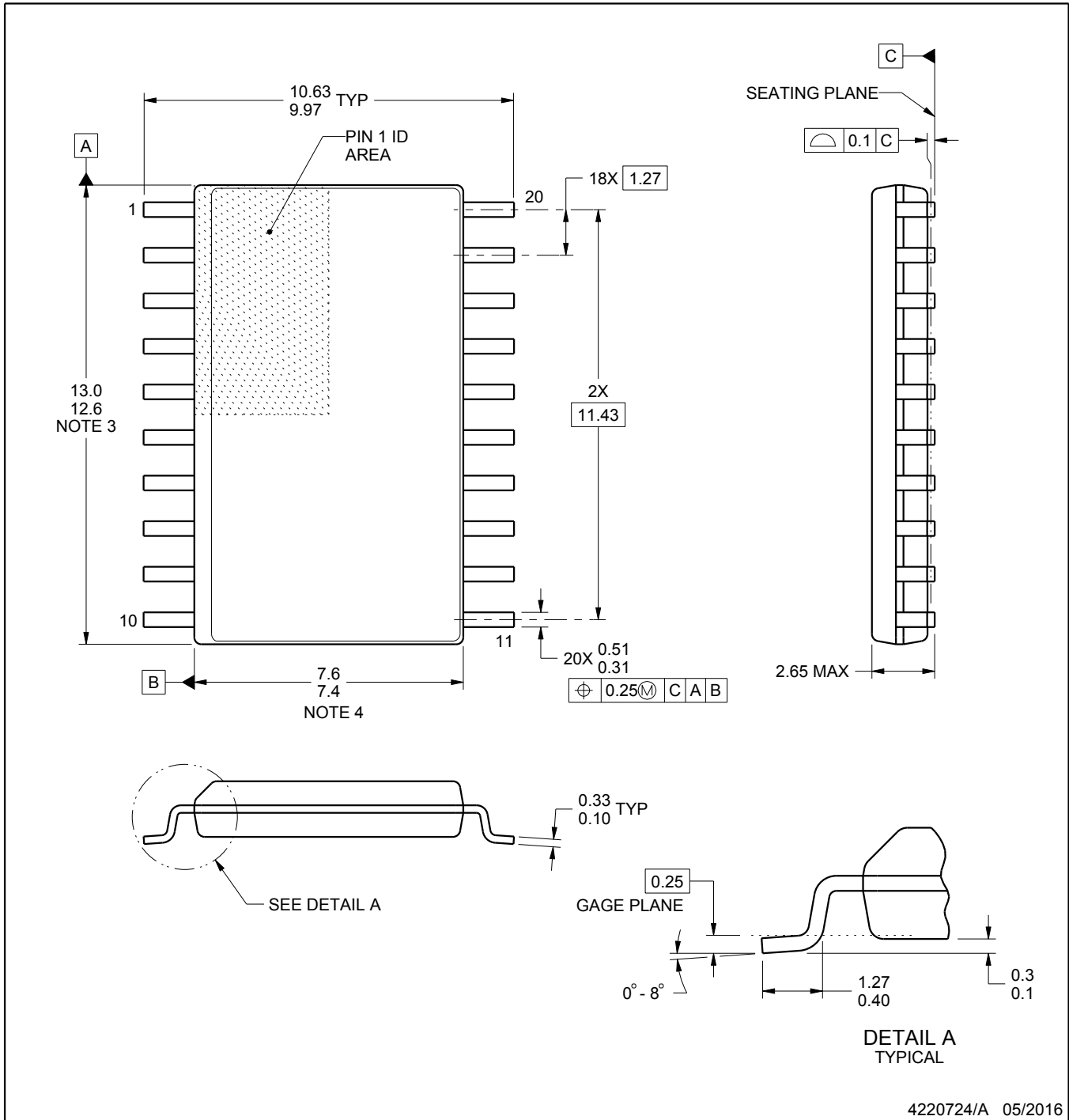

4220724/A 05/2016

NOTES:

1. All linear dimensions are in millimeters. Dimensions in parenthesis are for reference only. Dimensioning and tolerancing per ASME Y14.5M.
2. This drawing is subject to change without notice.
3. This dimension does not include mold flash, protrusions, or gate burrs. Mold flash, protrusions, or gate burrs shall not exceed 0.15 mm per side.
4. This dimension does not include interlead flash. Interlead flash shall not exceed 0.43 mm per side.
5. Reference JEDEC registration MS-013.

EXAMPLE BOARD LAYOUT

DW0020A

SOIC - 2.65 mm max height

SOIC



LAND PATTERN EXAMPLE
SCALE:6X



SOLDER MASK DETAILS

4220724/A 05/2016

NOTES: (continued)

- 6. Publication IPC-7351 may have alternate designs.
- 7. Solder mask tolerances between and around signal pads can vary based on board fabrication site.

EXAMPLE STENCIL DESIGN

DW0020A

SOIC - 2.65 mm max height

SOIC

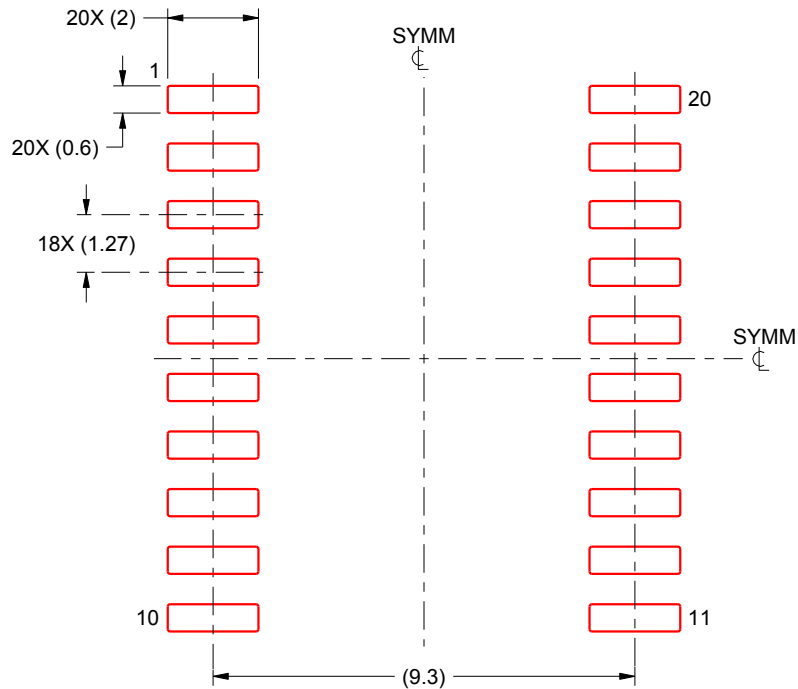

SOLDER PASTE EXAMPLE
BASED ON 0.125 mm THICK STENCIL
SCALE:6X

4220724/A 05/2016

NOTES: (continued)

8. Laser cutting apertures with trapezoidal walls and rounded corners may offer better paste release. IPC-7525 may have alternate design recommendations.
9. Board assembly site may have different recommendations for stencil design.

GENERIC PACKAGE VIEW

FK 20

LCCC - 2.03 mm max height

8.89 x 8.89, 1.27 mm pitch

LEADLESS CERAMIC CHIP CARRIER

This image is a representation of the package family, actual package may vary.
Refer to the product data sheet for package details.

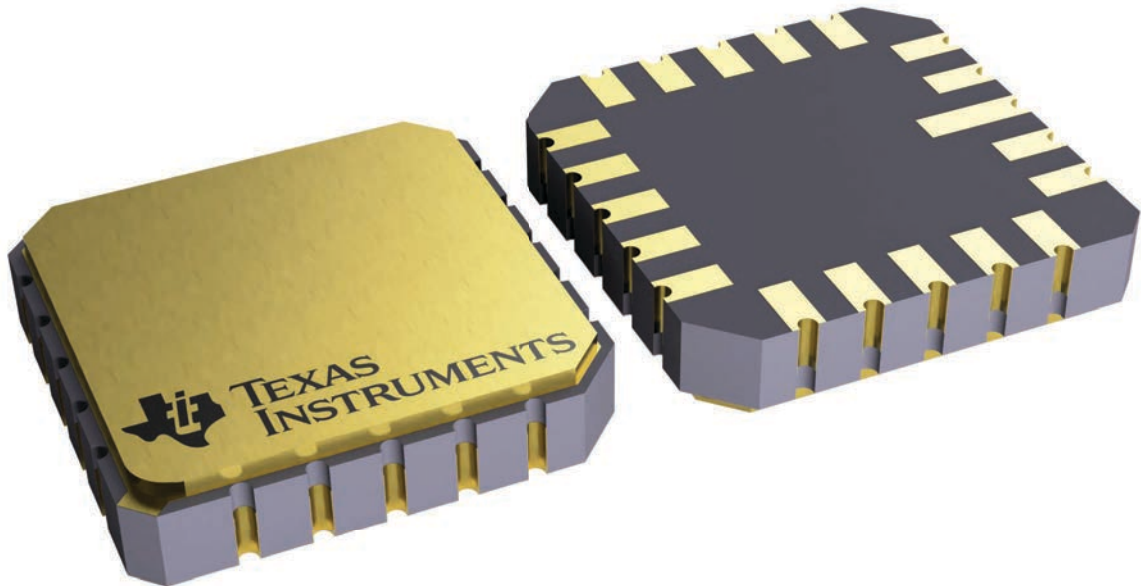

4229370VA\

重要通知和免责声明

TI“按原样”提供技术和可靠性数据（包括数据表）、设计资源（包括参考设计）、应用或其他设计建议、网络工具、安全信息和其他资源，不保证没有瑕疵且不做任何明示或暗示的担保，包括但不限于对适销性、与某特定用途的适用性或不侵犯任何第三方知识产权的暗示担保。

这些资源可供使用 TI 产品进行设计的熟练开发人员使用。您将自行承担以下全部责任：(1) 针对您的应用选择合适的 TI 产品，(2) 设计、验证并测试您的应用，(3) 确保您的应用满足相应标准以及任何其他安全、安保法规或其他要求。

这些资源如有变更，恕不另行通知。TI 授权您仅可将这些资源用于研发本资源所述的 TI 产品的相关应用。严禁以其他方式对这些资源进行复制或展示。您无权使用任何其他 TI 知识产权或任何第三方知识产权。对于因您对这些资源的使用而对 TI 及其代表造成的任何索赔、损害、成本、损失和债务，您将全额赔偿，TI 对此概不负责。

TI 提供的产品受 [TI 销售条款](#)、[TI 通用质量指南](#) 或 [ti.com](#) 上其他适用条款或 TI 产品随附的其他适用条款的约束。TI 提供这些资源并不会扩展或以其他方式更改 TI 针对 TI 产品发布的适用的担保或担保免责声明。除非德州仪器 (TI) 明确将某产品指定为定制产品或客户特定产品，否则其产品均为按确定价格收入目录的标准通用器件。

TI 反对并拒绝您可能提出的任何其他或不同的条款。

版权所有 © 2026，德州仪器 (TI) 公司

最后更新日期：2025 年 10 月