

SNx4AHC04 六路反相器

1 特性

- 工作电压范围为 2 V 至 5.5V
- 闩锁性能超过 250mA，符合 JESD 17 规范

2 说明

'AHC04 器件包含六个独立的反相器。这些器件执行布尔函数 $Y = \bar{A}$ 。

器件信息

器件型号	封装 ¹	封装尺寸 ²
SN54AHC04	J (CDIP , 14)	19.56mm x 6.67mm
	W (CFP , 14)	13.1 mm x 6.92 mm
	FK (LCCC , 20)	8.9 mm x 8.9 mm
SN74AHC04	N (PDIP , 14)	19.3mm x 6.35mm
	D (SOIC , 14)	8.65mm x 3.91mm
	DB (SSOP , 14)	6.20mm x 5.30mm
	NS (SOP , 14)	12.60mm x 5.30mm
	PW (TSSOP , 14)	5.00mm x 4.40mm
	DGV (TVSOP , 14)	3.6mm x 4.4mm
	RGY (VQFN , 14)	3.50mm x 3.50mm
	BQA (WQFN , 14)	3mm x 2.5mm

1. 如需了解所有可用封装，请参阅数据表末尾的可订购产品附录。
2. 封装尺寸（长 × 宽）为标称值，并包括引脚（如适用）。



图 2-1. 逻辑图，每个逻辑门（正逻辑）



Table of Contents

1 特性	1	5.9 Operating Characteristics.....	6
2 说明	1	6 Parameter Measurement Information	7
3 Revision History	2	7 Detailed Description	8
4 Pin Configuration and Functions	3	7.1 Functional Block Diagram.....	8
5 Specifications	4	7.2 Device Functional Modes.....	8
5.1 Absolute Maximum Ratings.....	4	8 Device and Documentation Support	9
5.2 ESD Ratings.....	4	8.1 Documentation Support (Analog).....	9
5.3 Recommended Operating Conditions	4	8.2 接收文档更新通知.....	9
5.4 Thermal Information.....	5	8.3 支持资源.....	9
5.5 Electrical Characteristics.....	5	8.4 Trademarks.....	9
5.6 Switching Characteristics.....	5	8.5 静电放电警告.....	9
5.7 Switching Characteristics, $V_{CC} = 5\text{ V} \pm 0.5\text{ V}$	6	8.6 术语表.....	9
5.8 Noise Characteristics.....	6	9 Mechanical, Packaging, and Orderable Information	9

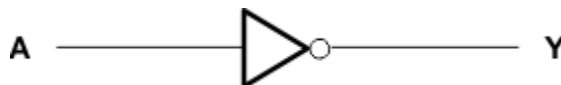
3 Revision History

注：以前版本的页码可能与当前版本的页码不同

Changes from Revision O (May 2023) to Revision P (June 2023)	Page
• 向 <i>器件信息</i> 表中添加了 BQA 封装.....	1
• 添加了 <i>器件和文档支持</i> 部分以及 <i>机械、封装和可订购信息</i> 部分.....	1
• Updated thermal values for R ^θ JA: D = 86 to 124.5, PW = 113 to 147.7, all values in °C/W	5
• Added thermal value for R ^θ JA: BQA = 88.3, all values in °C/W.....	5

Changes from Revision N (May 2013) to Revision O (May 2023)	Page
• 添加了 <i>封装信息表</i> 、 <i>引脚功能表</i> 和 <i>热性能信息表</i>	1

4 Pin Configuration and Functions



图 4-1. SN54AHC04 J or W Package SN74AHC04 D, DB, DGV, N, NS, or PW Package (Top View)

图 4-2. SN74AHC04 RGY or BQA Package (Top View)

图 4-3. SN54AHC04 FK Package (Top View)

表 4-1. Pin Functions

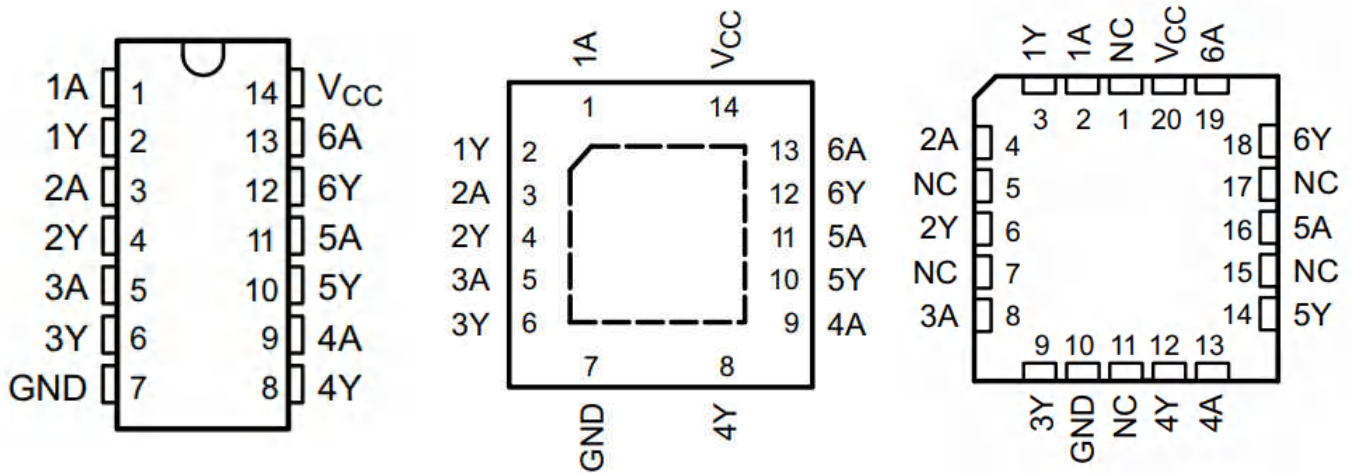
NAME	PIN				I/O	DESCRIPTION
	SN74AHC04		SN54AHC04			
	D, DB, DGV, N, NS, PW	RGY, BQA	J, W	FK		
1A	1	1	1	2	I	1A Input
1Y	2	2	2	3	O	1Y Output
2A	3	3	3	4	I	2A Input
2Y	4	4	4	6	O	2Y Output
3A	5	5	5	8	I	3A Input
3Y	6	6	6	9	O	3Y Output
4A	9	9	9	13	I	4A Input
4Y	8	8	8	12	O	4Y Output
5A	11	11	11	16	I	5A Input
5Y	10	10	10	14	I	5Y Output
6A	13	13	13	19	I	6A Input
6Y	12	12	12	18	O	6Y Output
GND	7	7	7	10	—	Ground Pin
NC	—	—	—	1	—	No Connection
				5		
				7		
				11		
				15		
V _{CC}	14	14	14	20	—	Power Pin

5 Specifications

5.1 Absolute Maximum Ratings

over operating free-air temperature range (unless otherwise noted)⁽¹⁾

		MIN	MAX	UNIT
V_{CC}	Supply voltage range	- 0.5	7	V
V_I ⁽²⁾	Input voltage range	- 0.5	7	V
V_O ⁽²⁾	Output voltage range	- 0.5	$V_{CC} + 0.5$	V
I_{IK}	Input clamp current	$(V_I < 0)$		- 20 mA
I_{OK}	Output clamp current	$(V_O < 0 \text{ or } V_O > V_{CC})$		± 20 mA
I_{OK}	Continuous output current	$(V_O = 0 \text{ to } V_{CC})$		± 25 mA
	Continuous current through V_{CC} or GND			± 50 mA
T_{stg}	Storage temperature range	- 65	150	$^{\circ}\text{C}$

- (1) Stresses beyond those listed under “absolute maximum ratings” may cause permanent damage to the device. These are stress ratings only, and functional operation of the device at these or any other conditions beyond those indicated under “recommended operating conditions” is not implied. Exposure to absolute-maximum-rated conditions for extended periods may affect device reliability.
- (2) The input and output voltage ratings may be exceeded if the input and output current ratings are observed.

5.2 ESD Ratings

		VALUE	UNIT
$V_{(ESD)}$	Electrostatic discharge		V
	Human body model (HBM), per ANSI/ESDA/JEDEC JS-001, all pins ⁽¹⁾	± 2000	
	Charged device model (CDM), per JEDEC specification JESD22-C101, all pins ⁽²⁾	± 1000	

- (1) JEDEC document JEP155 states that 500-V HBM allows safe manufacturing with a standard ESD control process.
- (2) JEDEC document JEP157 states that 250-V CDM allows safe manufacturing with a standard ESD control process.

5.3 Recommended Operating Conditions

		SN54AHC04		SN74AHC04		UNIT
		MIN	MAX	MIN	MAX	
V_{CC}	Supply voltage	2	5.5	2	5.5	V
V_{IH}	High-level input voltage	$V_{CC} = 2 \text{ V}$		1.5		V
		$V_{CC} = 3 \text{ V}$		2.1		
		$V_{CC} = 5.5 \text{ V}$		3.85		
V_{IL}	Low-level Input voltage	$V_{CC} = 2 \text{ V}$		0.5		V
		$V_{CC} = 3 \text{ V}$		0.9		
		$V_{CC} = 5.5 \text{ V}$		1.65		
V_I	Input voltage	0	5.5	0	5.5	V
V_O	Output voltage	0	V_{CC}	0	V_{CC}	V
I_{OH}	High-level output current	$V_{CC} = 2 \text{ V}$		- 50		mA
		$V_{CC} = 3.3 \text{ V} \pm 0.3 \text{ V}$		- 4		
		$V_{CC} = 5 \text{ V} \pm 0.5 \text{ V}$		- 8		
I_{OL}	Low-level output current	$V_{CC} = 2 \text{ V}$		50		mA
		$V_{CC} = 3.3 \text{ V} \pm 0.3 \text{ V}$		4		
		$V_{CC} = 5 \text{ V} \pm 0.5 \text{ V}$		8		
$\Delta t / \Delta v$	Input Transition rise or fall rate	$V_{CC} = 3.3 \text{ V} \pm 0.3 \text{ V}$		100		ns/V
		$V_{CC} = 5 \text{ V} \pm 0.5 \text{ V}$		20		
T_A	Operating free-air temperature	- 55	125	- 40	125	$^{\circ}\text{C}$

5.4 Thermal Information

THERMAL METRIC ¹		SNx4AHC04								UNIT
		D	DB	DGV	N	NS	PW	RGY	BQA	
		14 PINS								
R _{θJA}	Junction-to-ambient thermal resistance	124.5	96	127	80	76	147.7	47	88.3	°C/W

(1) For more information about traditional and new thermal metrics, see the *IC Package Thermal Metrics* application report, (SPRA953).

5.5 Electrical Characteristics

over operating free-air temperature range (unless otherwise noted)

PARAMETER	TEST CONDITIONS	V _{CC}	T _A = 25°C			T _A = -55°C TO 125°C		T _A = -40°C TO 85°C		T _A = -40°C TO 125°C		UNIT
						SN54AHC04		SN74AHC04		Recommended SN74AHC04		
			MIN	TYP	MAX	MIN	MAX	MIN	MAX	MIN	MAX	
V _{OH}	I _{OH} = -50 μA	2 V	1.9	2	1.9		1.9		1.9		V	
		3 V	2.9	3	2.9		2.9		2.9			
		4.5 V	4.4	4.5	4.4		4.4		4.4			
	I _{OH} = -4 mA	3 V	2.58		2.48		2.48		2.48			
		4.5 V	3.94		3.8		3.8		3.8			
V _{OL}	I _{OL} = 50 μA	2 V			0.1		0.1		0.1		V	
		3 V			0.1		0.1		0.1			
		4.5 V			0.1		0.1		0.1			
	I _{OH} = 4 mA	3 V			0.36		0.5		0.44			
		4.5 V			0.36		0.5		0.44			
I _I	V _I = 5.5 V or GND	0 V to 5.5 V			±0.1		±1 ⁽¹⁾		±1		μA	
I _{CC}	V _I = V _{CC} or GND, I _O = 0	5.5 V			2		20		20		μA	
C _i	V _I = V _{CC} or GND	5 V		2	10				10		pF	

(1) On products compliant to MIL-PRF-38535, this parameter is not production tested at V_{CC} = 0 V.

5.6 Switching Characteristics

over recommended operating free-air temperature range, V_{CC} = 3.3 V ± 0.3 V (unless otherwise noted) (see [Load Circuit and Voltage Waveforms](#))

PARAMETER	FROM (INPUT)	TO (OUTPUT)	LOAD CAPACITANCE	T _A = 25°C		T _A = -55°C TO 125°C		T _A = -40°C TO 85°C		T _A = -40°C TO 125°C		UNIT
						SN54AHC04		SN74AHC04		Recommended SN74AHC04		
				TYP	MAX	MIN	MAX	MIN	MAX	MIN	MAX	
t _{PLH}	A	Y	C _L = 15 pF	5 ⁽¹⁾	8.9 ⁽¹⁾	1 ⁽¹⁾	10.5 ⁽¹⁾	1	10.5	1	10.5	ns
t _{PHL}				5 ⁽¹⁾	8.9 ⁽¹⁾	1 ⁽¹⁾	10.5 ⁽¹⁾	1	10.5	1	10.5	
t _{PLH}	A	Y	C _L = 50 pF	7.5	11.4	1	13	1	13	1	13	ns
t _{PHL}				7.5	11.4	1	13	1	13	1	13	

(1) On products compliant to MIL-PRF-38535, this parameter is not production tested.

5.7 Switching Characteristics, $V_{CC} = 5 V \pm 0.5 V$

over recommended operating free-air temperature range, $V_{CC} = 5 V \pm 0.5 V$ (unless otherwise noted) (see [Load Circuit and Voltage Waveforms](#))

PARAMETER	FROM (INPUT)	TO (OUTPUT)	TEST CONDITIONS	$T_A = 25^\circ C$		$T_A = -55^\circ C$ TO $125^\circ C$		$T_A = -40^\circ C$ TO $85^\circ C$		$T_A = -40^\circ C$ TO $125^\circ C$		UNIT
				TYP	MAX	SN54AHC04		SN74AHC04		Recommended		
						MIN	MAX	MIN	MAX	MIN	MAX	
t_{PLH}	A	Y	$C_L = 15 \text{ pF}$	3.8 ¹	5.5 ¹	1 ¹	6.5 ¹	1	6.5	1	6.5	ns
t_{PHL}				3.8 ¹	5.5 ¹	1 ¹	6.5 ¹	1	6.5	1	6.5	
t_{PLH}	A	Y	$C_L = 50 \text{ pF}$	5.3	7.5	1	8.5	1	8.5	1	8.5	ns
t_{PHL}				5.3	7.5	1	8.5	1	8.5	1	8.5	

1. On products compliant to MIL-PRF-38535, this parameter is not production tested.

5.8 Noise Characteristics

$V_{CC} = 5 V$, $C_L = 50 \text{ pF}$, $T_A = 25^\circ C$ ⁽¹⁾

PARAMETER		SN74AHC04			UNIT
		MIN	TYP	MAX	
$V_{OL(P)}$	Quiet output, maximum dynamic V_{OL}		0.4		V
$V_{OL(V)}$	Quiet output, minimum dynamic V_{OL}		-0.4		V
$V_{OH(V)}$	Quiet output, minimum dynamic V_{OH}		4.8		V
$V_{IH(D)}$	High-level dynamic input voltage		3.5		V
$V_{IL(D)}$	Low-level dynamic input voltage			1.5	V

(1) Characteristics are for surface-mount packages only.

5.9 Operating Characteristics

$V_{CC} = 5 V$, $T_A = 25^\circ C$

PARAMETER	TEST CONDITIONS	TYP	UNIT
C_{pd}	No load, $f = 1 \text{ MHz}$	12	pF

6 Parameter Measurement Information

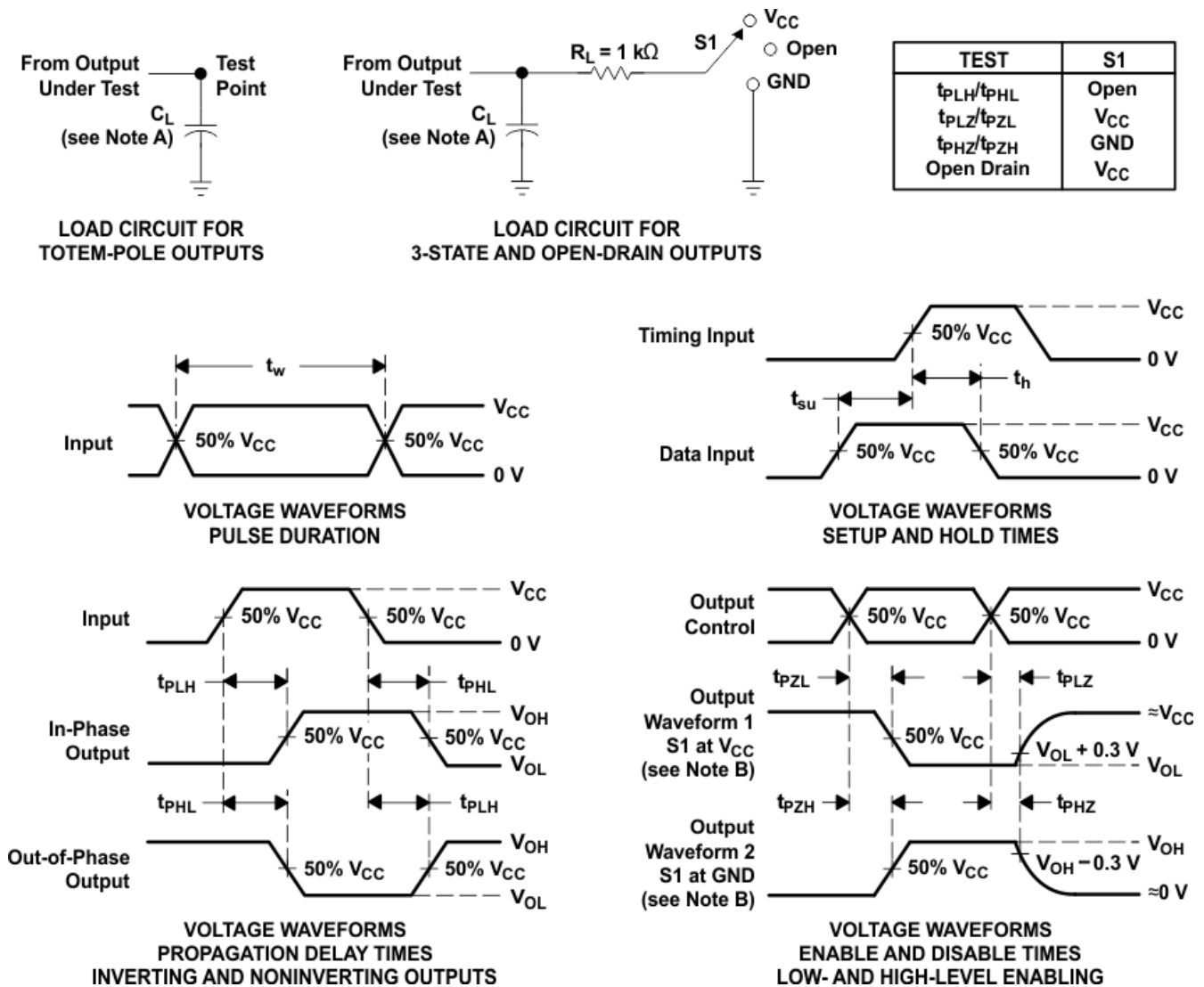

- C_L includes probe and jig capacitance.
- Waveform 1 is for an output with internal conditions such that the output is low except when disabled by the output control. Waveform 2 is for an output with internal conditions such that the output is high except when disabled by the output control.
- All input pulses are supplied by generators having the following characteristics: $PRR \leq 1$ MHz, $Z_O = 50 \Omega$, $t_r \leq 3$ ns, $t_f \leq 3$ ns.
- The outputs are measured one at a time with one input transition per measurement.
- All parameters and waveforms are not applicable to all devices.

图 6-1. Load Circuit and Voltage Waveforms

7 Detailed Description

7.1 Functional Block Diagram

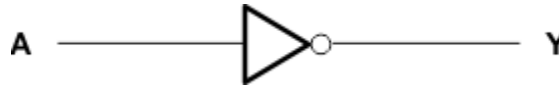

7.2 Device Functional Modes

表 7-1. Function Table
(Each Inverter)

INPUT A	OUTPUT Y
H	L
L	H

8 Device and Documentation Support

8.1 Documentation Support (Analog)

8.1.1 Related Documentation

The table below lists quick access links. Categories include technical documents, support and community resources, tools and software, and quick access to sample or buy.

表 8-1. Related Links

PARTS	PRODUCT FOLDER	SAMPLE & BUY	TECHNICAL DOCUMENTS	TOOLS & SOFTWARE	SUPPORT & COMMUNITY
SN54AHC04	Click here	Click here	Click here	Click here	Click here
SN74AHC04	Click here	Click here	Click here	Click here	Click here

8.2 接收文档更新通知

要接收文档更新通知，请导航至 ti.com 上的器件产品文件夹。点击 [订阅更新](#) 进行注册，即可每周接收产品信息更改摘要。有关更改的详细信息，请查看任何已修订文档中包含的修订历史记录。

8.3 支持资源

TI E2E™ 支持论坛 是工程师的重要参考资料，可直接从专家获得快速、经过验证的解答和设计帮助。搜索现有解答或提出自己的问题可获得所需的快速设计帮助。

链接的内容由各个贡献者“按原样”提供。这些内容并不构成 TI 技术规范，并且不一定反映 TI 的观点；请参阅 TI 的《[使用条款](#)》。

8.4 Trademarks

TI E2E™ is a trademark of Texas Instruments.

所有商标均为其各自所有者的财产。

8.5 静电放电警告



静电放电 (ESD) 会损坏这个集成电路。德州仪器 (TI) 建议通过适当的预防措施处理所有集成电路。如果不遵守正确的处理和安装程序，可能会损坏集成电路。

ESD 的损坏小至导致微小的性能降级，大至整个器件故障。精密的集成电路可能更容易受到损坏，这是因为非常细微的参数更改都可能会导致器件与其发布的规格不相符。

8.6 术语表

TI 术语表 本术语表列出并解释了术语、首字母缩略词和定义。

9 Mechanical, Packaging, and Orderable Information

The following pages include mechanical, packaging, and orderable information. This information is the most current data available for the designated devices. This data is subject to change without notice and revision of this document. For browser-based versions of this data sheet, refer to the left-hand navigation.

PACKAGING INFORMATION

Orderable Device	Status (1)	Package Type	Package Drawing	Pins	Package Qty	Eco Plan (2)	Lead finish/ Ball material (6)	MSL Peak Temp (3)	Op Temp (°C)	Device Marking (4/5)	Samples
5962-9680501Q2A	ACTIVE	LCCC	FK	20	55	Non-RoHS & Green	SNPB	N / A for Pkg Type	-55 to 125	5962-9680501Q2A SNJ54AHC04FK	Samples
5962-9680501QCA	ACTIVE	CDIP	J	14	25	Non-RoHS & Green	SNPB	N / A for Pkg Type	-55 to 125	5962-9680501QCA SNJ54AHC04J	Samples
5962-9680501QDA	ACTIVE	CFP	W	14	25	Non-RoHS & Green	SNPB	N / A for Pkg Type	-55 to 125	5962-9680501QDA SNJ54AHC04W	Samples
SN74AHC04BQAR	ACTIVE	WQFN	BQA	14	3000	RoHS & Green	NIPDAU	Level-1-260C-UNLIM	-40 to 125	AHC04	Samples
SN74AHC04D	OBSOLETE	SOIC	D	14		TBD	Call TI	Call TI	-40 to 125	AHC04	
SN74AHC04DBR	ACTIVE	SSOP	DB	14	2000	RoHS & Green	NIPDAU	Level-1-260C-UNLIM	-40 to 125	HA04	Samples
SN74AHC04DGVR	ACTIVE	TVSOP	DGV	14	2000	RoHS & Green	NIPDAU	Level-1-260C-UNLIM	-40 to 125	HA04	Samples
SN74AHC04DR	ACTIVE	SOIC	D	14	2500	RoHS & Green	NIPDAU	Level-1-260C-UNLIM	-40 to 125	AHC04	Samples
SN74AHC04N	ACTIVE	PDIP	N	14	25	RoHS & Green	NIPDAU	N / A for Pkg Type	-40 to 125	SN74AHC04N	Samples
SN74AHC04NSR	ACTIVE	SO	NS	14	2000	RoHS & Green	NIPDAU	Level-1-260C-UNLIM	-40 to 125	AHC04	Samples
SN74AHC04PW	OBSOLETE	TSSOP	PW	14		TBD	Call TI	Call TI	-40 to 125	HA04	
SN74AHC04PWR	ACTIVE	TSSOP	PW	14	2000	RoHS & Green	NIPDAU	Level-1-260C-UNLIM	-40 to 125	HA04	Samples
SN74AHC04RGYR	ACTIVE	VQFN	RGY	14	3000	RoHS & Green	NIPDAU	Level-2-260C-1 YEAR	-40 to 125	HA04	Samples
SNJ54AHC04FK	ACTIVE	LCCC	FK	20	55	Non-RoHS & Green	SNPB	N / A for Pkg Type	-55 to 125	5962-9680501Q2A SNJ54AHC04FK	Samples
SNJ54AHC04J	ACTIVE	CDIP	J	14	25	Non-RoHS & Green	SNPB	N / A for Pkg Type	-55 to 125	5962-9680501QCA SNJ54AHC04J	Samples
SNJ54AHC04W	ACTIVE	CFP	W	14	25	Non-RoHS & Green	SNPB	N / A for Pkg Type	-55 to 125	5962-9680501QDA SNJ54AHC04W	Samples

Orderable Device	Status (1)	Package Type	Package Drawing	Pins	Package Qty	Eco Plan (2)	Lead finish/ Ball material (6)	MSL Peak Temp (3)	Op Temp (°C)	Device Marking (4/5)	Samples
										SNJ54AHC04W	

(1) The marketing status values are defined as follows:

ACTIVE: Product device recommended for new designs.

LIFEBUY: TI has announced that the device will be discontinued, and a lifetime-buy period is in effect.

NRND: Not recommended for new designs. Device is in production to support existing customers, but TI does not recommend using this part in a new design.

PREVIEW: Device has been announced but is not in production. Samples may or may not be available.

OBSOLETE: TI has discontinued the production of the device.

(2) **RoHS:** TI defines "RoHS" to mean semiconductor products that are compliant with the current EU RoHS requirements for all 10 RoHS substances, including the requirement that RoHS substance do not exceed 0.1% by weight in homogeneous materials. Where designed to be soldered at high temperatures, "RoHS" products are suitable for use in specified lead-free processes. TI may reference these types of products as "Pb-Free".

RoHS Exempt: TI defines "RoHS Exempt" to mean products that contain lead but are compliant with EU RoHS pursuant to a specific EU RoHS exemption.

Green: TI defines "Green" to mean the content of Chlorine (Cl) and Bromine (Br) based flame retardants meet JS709B low halogen requirements of <=1000ppm threshold. Antimony trioxide based flame retardants must also meet the <=1000ppm threshold requirement.

(3) MSL, Peak Temp. - The Moisture Sensitivity Level rating according to the JEDEC industry standard classifications, and peak solder temperature.

(4) There may be additional marking, which relates to the logo, the lot trace code information, or the environmental category on the device.

(5) Multiple Device Markings will be inside parentheses. Only one Device Marking contained in parentheses and separated by a "~" will appear on a device. If a line is indented then it is a continuation of the previous line and the two combined represent the entire Device Marking for that device.

(6) Lead finish/Ball material - Orderable Devices may have multiple material finish options. Finish options are separated by a vertical ruled line. Lead finish/Ball material values may wrap to two lines if the finish value exceeds the maximum column width.

Important Information and Disclaimer:The information provided on this page represents TI's knowledge and belief as of the date that it is provided. TI bases its knowledge and belief on information provided by third parties, and makes no representation or warranty as to the accuracy of such information. Efforts are underway to better integrate information from third parties. TI has taken and continues to take reasonable steps to provide representative and accurate information but may not have conducted destructive testing or chemical analysis on incoming materials and chemicals. TI and TI suppliers consider certain information to be proprietary, and thus CAS numbers and other limited information may not be available for release.

In no event shall TI's liability arising out of such information exceed the total purchase price of the TI part(s) at issue in this document sold by TI to Customer on an annual basis.

OTHER QUALIFIED VERSIONS OF SN54AHC04, SN74AHC04 :

- Catalog : [SN74AHC04](#)

- Automotive : [SN74AHC04-Q1](#), [SN74AHC04-Q1](#)
- Enhanced Product : [SN74AHC04-EP](#), [SN74AHC04-EP](#)
- Military : [SN54AHC04](#)

NOTE: Qualified Version Definitions:

- Catalog - TI's standard catalog product
- Automotive - Q100 devices qualified for high-reliability automotive applications targeting zero defects
- Enhanced Product - Supports Defense, Aerospace and Medical Applications
- Military - QML certified for Military and Defense Applications

TAPE AND REEL INFORMATION

QUADRANT ASSIGNMENTS FOR PIN 1 ORIENTATION IN TAPE

*All dimensions are nominal

Device	Package Type	Package Drawing	Pins	SPQ	Reel Diameter (mm)	Reel Width W1 (mm)	A0 (mm)	B0 (mm)	K0 (mm)	P1 (mm)	W (mm)	Pin1 Quadrant
SN74AHC04BQAR	WQFN	BQA	14	3000	180.0	12.4	2.8	3.3	1.1	4.0	12.0	Q1
SN74AHC04DBR	SSOP	DB	14	2000	330.0	16.4	8.35	6.6	2.4	12.0	16.0	Q1
SN74AHC04DGVR	TVSOP	DGV	14	2000	330.0	12.4	6.8	4.0	1.6	8.0	12.0	Q1
SN74AHC04DR	SOIC	D	14	2500	330.0	16.4	6.5	9.0	2.1	8.0	16.0	Q1
SN74AHC04NSR	SO	NS	14	2000	330.0	16.4	8.2	10.5	2.5	12.0	16.0	Q1
SN74AHC04PWR	TSSOP	PW	14	2000	330.0	12.4	6.9	5.6	1.6	8.0	12.0	Q1
SN74AHC04RGYR	VQFN	RGY	14	3000	330.0	12.4	3.75	3.75	1.15	8.0	12.0	Q1

TAPE AND REEL BOX DIMENSIONS

*All dimensions are nominal

Device	Package Type	Package Drawing	Pins	SPQ	Length (mm)	Width (mm)	Height (mm)
SN74AHC04BQAR	WQFN	BQA	14	3000	210.0	185.0	35.0
SN74AHC04DBR	SSOP	DB	14	2000	356.0	356.0	35.0
SN74AHC04DGVR	TVSOP	DGV	14	2000	356.0	356.0	35.0
SN74AHC04DR	SOIC	D	14	2500	356.0	356.0	35.0
SN74AHC04NSR	SO	NS	14	2000	356.0	356.0	35.0
SN74AHC04PWR	TSSOP	PW	14	2000	356.0	356.0	35.0
SN74AHC04RGYR	VQFN	RGY	14	3000	356.0	356.0	35.0

TUBE

*All dimensions are nominal

Device	Package Name	Package Type	Pins	SPQ	L (mm)	W (mm)	T (μm)	B (mm)
5962-9680501Q2A	FK	LCCC	20	55	506.98	12.06	2030	NA
5962-9680501QDA	W	CFP	14	25	506.98	26.16	6220	NA
SN74AHC04N	N	PDIP	14	25	506	13.97	11230	4.32
SN74AHC04N	N	PDIP	14	25	506	13.97	11230	4.32
SNJ54AHC04FK	FK	LCCC	20	55	506.98	12.06	2030	NA
SNJ54AHC04W	W	CFP	14	25	506.98	26.16	6220	NA

RGY (S-PVQFN-N14)

PLASTIC QUAD FLATPACK NO-LEAD



- NOTES:
- All linear dimensions are in millimeters. Dimensioning and tolerancing per ASME Y14.5M-1994.
 - This drawing is subject to change without notice.
 - QFN (Quad Flatpack No-Lead) package configuration.
 - The package thermal pad must be soldered to the board for thermal and mechanical performance.
 - See the additional figure in the Product Data Sheet for details regarding the exposed thermal pad features and dimensions.
 - Pin 1 identifiers are located on both top and bottom of the package and within the zone indicated. The Pin 1 identifiers are either a molded, marked, or metal feature.
 - Package complies to JEDEC MO-241 variation BA.

RGY (S-PVQFN-N14)

PLASTIC QUAD FLATPACK NO-LEAD

THERMAL INFORMATION

This package incorporates an exposed thermal pad that is designed to be attached directly to an external heatsink. The thermal pad must be soldered directly to the printed circuit board (PCB). After soldering, the PCB can be used as a heatsink. In addition, through the use of thermal vias, the thermal pad can be attached directly to the appropriate copper plane shown in the electrical schematic for the device, or alternatively, can be attached to a special heatsink structure designed into the PCB. This design optimizes the heat transfer from the integrated circuit (IC).

For information on the Quad Flatpack No-Lead (QFN) package and its advantages, refer to Application Report, QFN/SON PCB Attachment, Texas Instruments Literature No. SLUA271. This document is available at www.ti.com.

The exposed thermal pad dimensions for this package are shown in the following illustration.

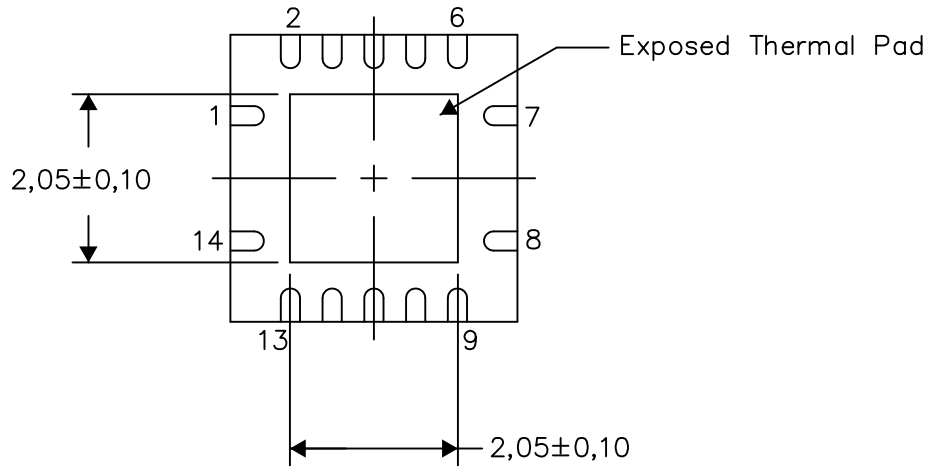

Bottom View

Exposed Thermal Pad Dimensions

4206353-2/P 03/14

NOTE: All linear dimensions are in millimeters

RGY (S-PVQFN-N14)

PLASTIC QUAD FLATPACK NO-LEAD



- NOTES:
- All linear dimensions are in millimeters.
 - This drawing is subject to change without notice.
 - Publication IPC-7351 is recommended for alternate designs.
 - This package is designed to be soldered to a thermal pad on the board. Refer to Application Note, Quad Flat-Pack QFN/SON PCB Attachment, Texas Instruments Literature No. SLUA271, and also the Product Data Sheets for specific thermal information, via requirements, and recommended board layout. These documents are available at www.ti.com <<http://www.ti.com>>.
 - Laser cutting apertures with trapezoidal walls and also rounding corners will offer better paste release. Customers should contact their board assembly site for stencil design recommendations. Refer to IPC 7525 for stencil design considerations.
 - Customers should contact their board fabrication site for minimum solder mask web tolerances between signal pads.

GENERIC PACKAGE VIEW

BQA 14

WQFN - 0.8 mm max height

2.5 x 3, 0.5 mm pitch

PLASTIC QUAD FLATPACK - NO LEAD

This image is a representation of the package family, actual package may vary.
Refer to the product data sheet for package details.

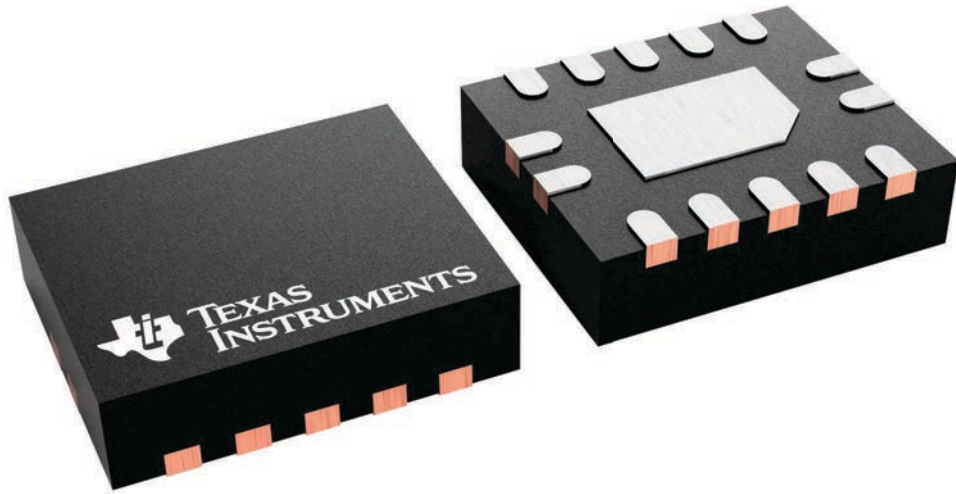

4227145/A

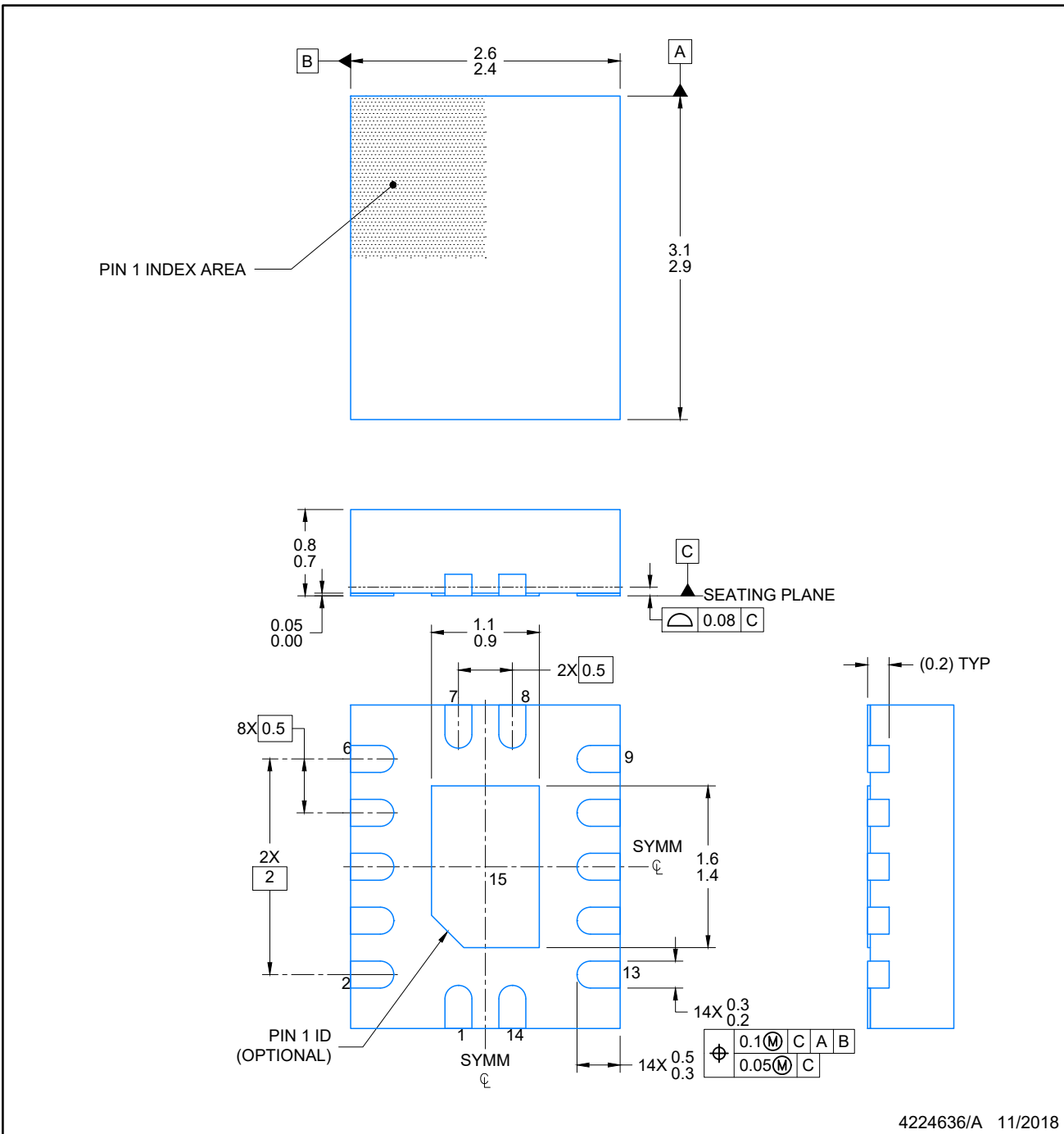

4224636/A 11/2018

NOTES:

1. All linear dimensions are in millimeters. Any dimensions in parenthesis are for reference only. Dimensioning and tolerancing per ASME Y14.5M.
2. This drawing is subject to change without notice.
3. The package thermal pad must be soldered to the printed circuit board for optimal thermal and mechanical performance.

EXAMPLE BOARD LAYOUT

WQFN - 0.8 mm max height

BQA0014A

PLASTIC QUAD FLAT PACK-NO LEAD

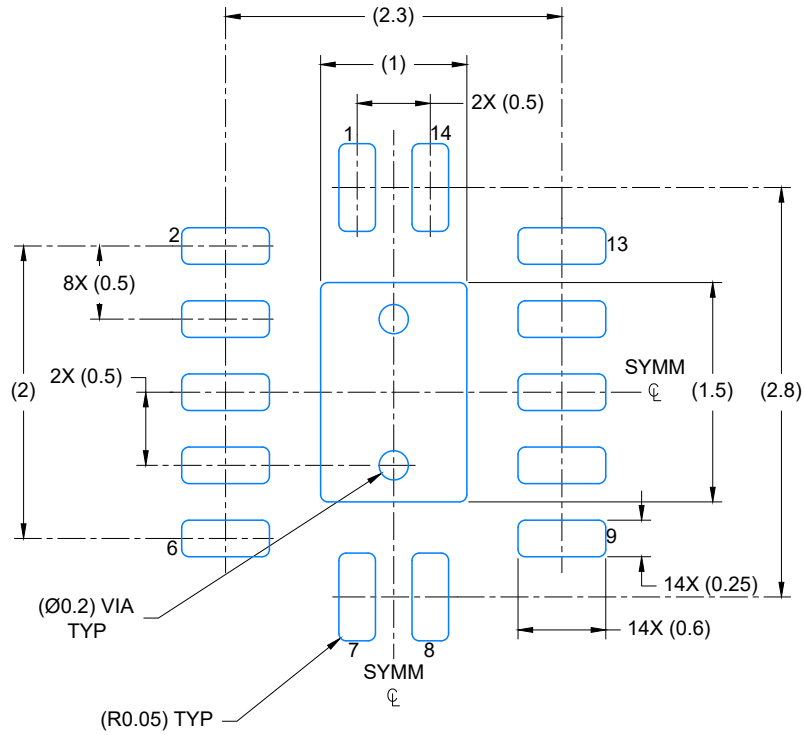

LAND PATTERN EXAMPLE
EXPOSED METAL SHOWN
SCALE: 20X

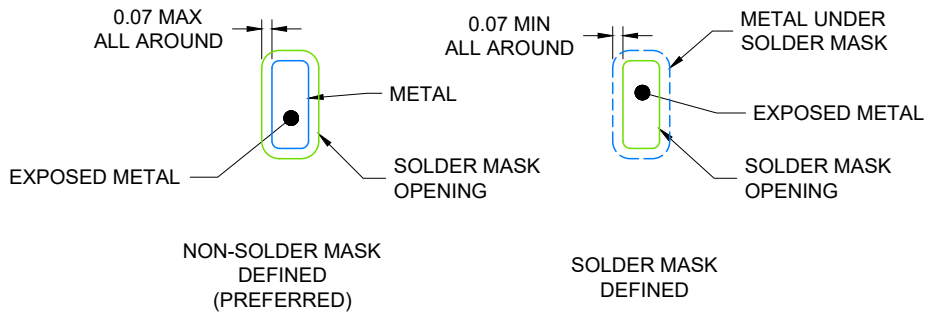

4224636/A 11/2018

NOTES: (continued)

4. This package is designed to be soldered to a thermal pad on the board. For more information, see Texas Instruments literature number SLUA271 (www.ti.com/lit/slua271).
5. Vias are optional depending on application, refer to device data sheet. If any vias are implemented, refer to their locations shown on this view. It is recommended that vias under paste be filled, plugged or tented.

EXAMPLE STENCIL DESIGN

BQA0014A

WQFN - 0.8 mm max height

PLASTIC QUAD FLAT PACK-NO LEAD

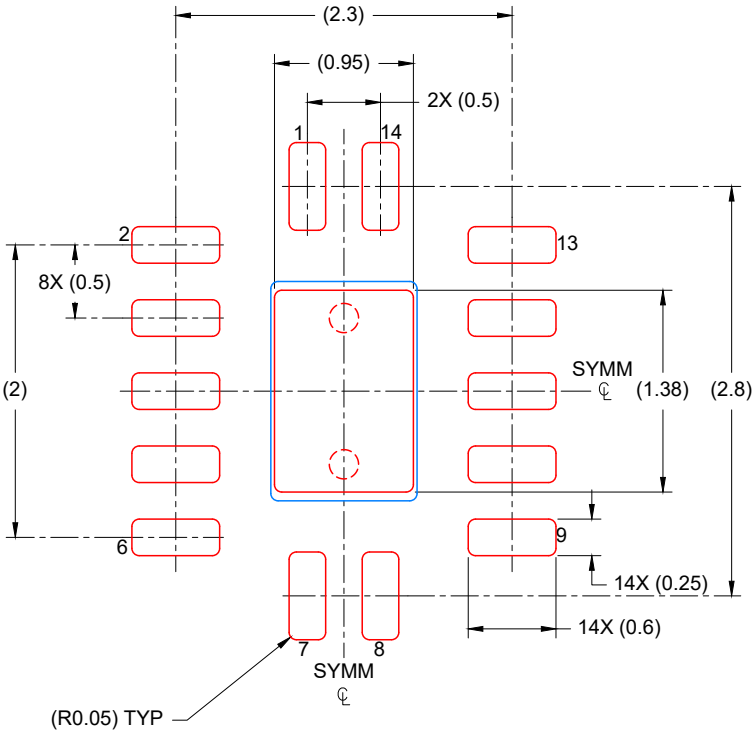

SOLDER PASTE EXAMPLE
 BASED ON 0.125 mm THICK STENCIL

EXPOSED PAD
 88% PRINTED COVERAGE BY AREA
 SCALE: 20X

4224636/A 11/2018

NOTES: (continued)

- 6. Laser cutting apertures with trapezoidal walls and rounded corners may offer better paste release. IPC-7525 may have alternate design recommendations.

MECHANICAL DATA

NS (R-PDSO-G**)

PLASTIC SMALL-OUTLINE PACKAGE

14-PINS SHOWN



- NOTES:
- A. All linear dimensions are in millimeters.
 - B. This drawing is subject to change without notice.
 - C. Body dimensions do not include mold flash or protrusion, not to exceed 0,15.

W (R-GDFP-F14)

CERAMIC DUAL FLATPACK



- NOTES:
- A. All linear dimensions are in inches (millimeters).
 - B. This drawing is subject to change without notice.
 - C. This package can be hermetically sealed with a ceramic lid using glass frit.
 - D. Index point is provided on cap for terminal identification only.
 - E. Falls within MIL STD 1835 GDFP1-F14

DGV (R-PDSO-G**)

PLASTIC SMALL-OUTLINE

24 PINS SHOWN



- NOTES: A. All linear dimensions are in millimeters.
 B. This drawing is subject to change without notice.
 C. Body dimensions do not include mold flash or protrusion, not to exceed 0,15 per side.
 D. Falls within JEDEC: 24/48 Pins – MO-153
 14/16/20/56 Pins – MO-194

DB0014A



PACKAGE OUTLINE

SSOP - 2 mm max height

SMALL OUTLINE PACKAGE



NOTES:

1. All linear dimensions are in millimeters. Any dimensions in parenthesis are for reference only. Dimensioning and tolerancing per ASME Y14.5M.
2. This drawing is subject to change without notice.
3. This dimension does not include mold flash, protrusions, or gate burrs. Mold flash, protrusions, or gate burrs shall not exceed 0.15 mm per side.
4. Reference JEDEC registration MO-150.

EXAMPLE BOARD LAYOUT

DB0014A

SSOP - 2 mm max height

SMALL OUTLINE PACKAGE



LAND PATTERN EXAMPLE
EXPOSED METAL SHOWN
SCALE: 10X



4220762/A 05/2024

NOTES: (continued)

- 5. Publication IPC-7351 may have alternate designs.
- 6. Solder mask tolerances between and around signal pads can vary based on board fabrication site.

EXAMPLE STENCIL DESIGN

DB0014A

SSOP - 2 mm max height

SMALL OUTLINE PACKAGE



SOLDER PASTE EXAMPLE
BASED ON 0.125 mm THICK STENCIL
SCALE: 10X

4220762/A 05/2024

NOTES: (continued)

7. Laser cutting apertures with trapezoidal walls and rounded corners may offer better paste release. IPC-7525 may have alternate design recommendations.
8. Board assembly site may have different recommendations for stencil design.

GENERIC PACKAGE VIEW

FK 20

LCCC - 2.03 mm max height

8.89 x 8.89, 1.27 mm pitch

LEADLESS CERAMIC CHIP CARRIER

This image is a representation of the package family, actual package may vary.
Refer to the product data sheet for package details.



4229370VA\

J 14

GENERIC PACKAGE VIEW
CDIP - 5.08 mm max height
CERAMIC DUAL IN LINE PACKAGE



Images above are just a representation of the package family, actual package may vary.
Refer to the product data sheet for package details.

4040083-5/G

J0014A



PACKAGE OUTLINE

CDIP - 5.08 mm max height

CERAMIC DUAL IN LINE PACKAGE



4214771/A 05/2017

NOTES:

1. All controlling linear dimensions are in inches. Dimensions in brackets are in millimeters. Any dimension in brackets or parenthesis are for reference only. Dimensioning and tolerancing per ASME Y14.5M.
2. This drawing is subject to change without notice.
3. This package is hermetically sealed with a ceramic lid using glass frit.
4. Index point is provided on cap for terminal identification only and on press ceramic glass frit seal only.
5. Falls within MIL-STD-1835 and GDIP1-T14.

EXAMPLE BOARD LAYOUT

J0014A

CDIP - 5.08 mm max height

CERAMIC DUAL IN LINE PACKAGE



LAND PATTERN EXAMPLE
NON-SOLDER MASK DEFINED
SCALE: 5X



4214771/A 05/2017

D (R-PDSO-G14)

PLASTIC SMALL OUTLINE



4211283-3/E 08/12

- NOTES:
- All linear dimensions are in millimeters.
 - This drawing is subject to change without notice.
 - Publication IPC-7351 is recommended for alternate designs.
 - Laser cutting apertures with trapezoidal walls and also rounding corners will offer better paste release. Customers should contact their board assembly site for stencil design recommendations. Refer to IPC-7525 for other stencil recommendations.
 - Customers should contact their board fabrication site for solder mask tolerances between and around signal pads.

N (R-PDIP-T**)

PLASTIC DUAL-IN-LINE PACKAGE

16 PINS SHOWN



4040049/E 12/2002

- NOTES:
- A. All linear dimensions are in inches (millimeters).
 - B. This drawing is subject to change without notice.
 - $\triangle C$ Falls within JEDEC MS-001, except 18 and 20 pin minimum body length (Dim A).
 - $\triangle D$ The 20 pin end lead shoulder width is a vendor option, either half or full width.

重要声明和免责声明

TI“按原样”提供技术和可靠性数据（包括数据表）、设计资源（包括参考设计）、应用或其他设计建议、网络工具、安全信息和其他资源，不保证没有瑕疵且不做任何明示或暗示的担保，包括但不限于对适销性、某特定用途方面的适用性或不侵犯任何第三方知识产权的暗示担保。

这些资源可供使用 TI 产品进行设计的熟练开发人员使用。您将自行承担以下全部责任：(1) 针对您的应用选择合适的 TI 产品，(2) 设计、验证并测试您的应用，(3) 确保您的应用满足相应标准以及任何其他功能安全、信息安全、监管或其他要求。

这些资源如有变更，恕不另行通知。TI 授权您仅可将这些资源用于研发本资源所述的 TI 产品的应用。严禁对这些资源进行其他复制或展示。您无权使用任何其他 TI 知识产权或任何第三方知识产权。您应全额赔偿因在这些资源的使用中对 TI 及其代表造成的任何索赔、损害、成本、损失和债务，TI 对此概不负责。

TI 提供的产品受 [TI 的销售条款](#) 或 [ti.com](#) 上其他适用条款/TI 产品随附的其他适用条款的约束。TI 提供这些资源并不会扩展或以其他方式更改 TI 针对 TI 产品发布的适用的担保或担保免责声明。

TI 反对并拒绝您可能提出的任何其他或不同的条款。

邮寄地址：Texas Instruments, Post Office Box 655303, Dallas, Texas 75265
Copyright © 2024，德州仪器 (TI) 公司