

## SNx4HC259 8 位可寻址锁存器

### 1 特性

- 2V 至 6V 的宽工作电压范围
- 高电流反相输出可驱动多达 10 个 LSTTL 负载
- 低功耗， $I_{CC}$  最大值为 80  $\mu$ A
- $t_{pd}$  典型值 = 14 ns
- 5V 时的输出驱动为  $\pm 4$  mA
- 低输入电流，最大值 1  $\mu$ A
- 8 位并行输出存储寄存器与存储器进行串行至并行转换
- 异步并行清除
- 高电平有效解码器
- 使能输入可简化扩展
- 可针对 n 位应用进行扩展
- 四种不同的功能模式

### 2 说明

这些 8 位可寻址锁存器专为数字系统中的通用存储应用而设计。具体应用包括工作寄存器、串行保持寄存器和高电平有效解码器或多路信号分离器。这类器件功能多样，既可以作为 8 位可寻址锁存器来存储单线数据，又能用作 8 选 1 解码器或多路信号分离器并提供高电平有效输出。

#### 器件信息

器件型号	封装 <sup>(1)</sup>	封装尺寸 (标称值)
SN74HC259D	SOIC (16)	9.90mm × 3.90mm
SN74HC259N	PDIP (16)	19.31mm × 6.35mm
SN74HC259NS	SO (16)	6.20mm × 5.30mm
SN74HC259PW	TSSOP (16)	5.00mm × 4.40mm
SN54HC259J	CDIP (16)	24.38mm × 6.92mm
SNJ54HC259FK	LCCC (20)	8.89mm × 8.45mm

(1) 如需了解所有可用封装，请参阅文档末尾的可订购产品附录。

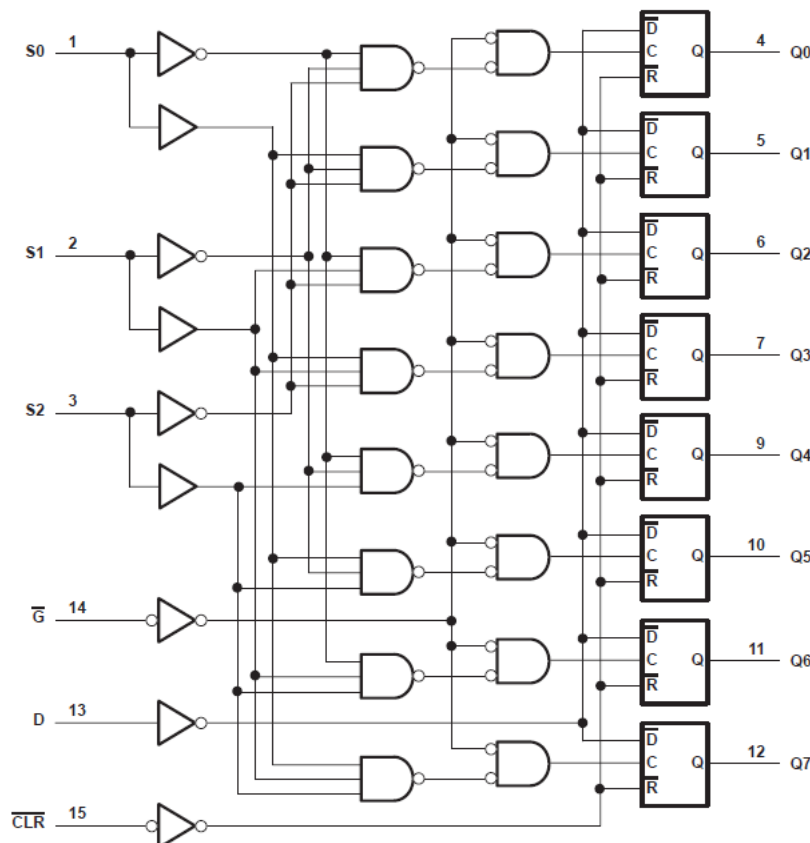

引脚编号用于 D、J、N、NS、PW 和 W 封装。

#### 功能框图



## Table of Contents

<b>1 特性</b> .....	1	7.1 Overview.....	8
<b>2 说明</b> .....	1	7.2 Functional Block Diagram.....	8
<b>3 Revision History</b> .....	2	7.3 Device Functional Modes.....	9
<b>4 Pin Configuration and Functions</b> .....	3	<b>8 Power Supply Recommendations</b> .....	10
<b>5 Specifications</b> .....	4	<b>9 Layout</b> .....	10
5.1 Absolute Maximum Ratings.....	4	9.1 Layout Guidelines.....	10
5.2 Recommended Operating Conditions <sup>(1)</sup> .....	4	<b>10 Device and Documentation Support</b> .....	11
5.3 Thermal Information.....	4	10.1 接收文档更新通知.....	11
5.4 Electrical Characteristics.....	5	10.2 支持资源.....	11
5.5 Timing Requirements.....	5	10.3 Trademarks.....	11
5.6 Switching Characteristics.....	6	10.4 Electrostatic Discharge Caution.....	11
5.7 Operating Characteristics.....	6	10.5 术语表.....	11
<b>6 Parameter Measurement Information</b> .....	7	<b>11 Mechanical, Packaging, and Orderable Information</b> .....	11
<b>7 Detailed Description</b> .....	8		

### 3 Revision History

注：以前版本的页码可能与当前版本的页码不同

<b>Changes from Revision E (September 2003) to Revision F (March 2022)</b>	<b>Page</b>
• 更新了整个文档中的编号、格式、表格、图和交叉参考，以反映现代数据表标准.....	1

## 4 Pin Configuration and Functions

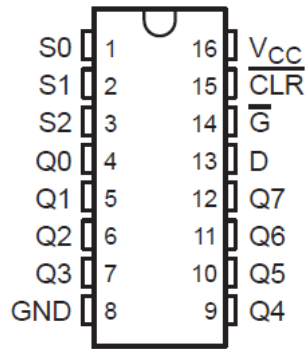

**J, D, N, NS, or PW Package**  
**16-Pin CDIP, SOIC, PDIP, SO, TSSOP**  
**Top View**

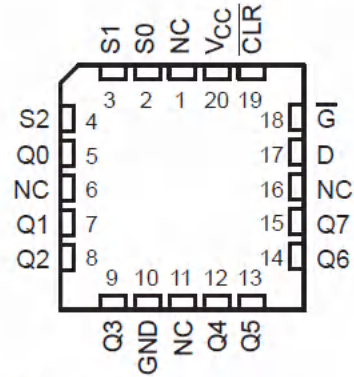

NC - No internal connection

**FK Package**  
**20-Pin LCCC**  
**Top View**

## 5 Specifications

### 5.1 Absolute Maximum Ratings

over operating free-air temperature range (unless otherwise noted)<sup>(1)</sup>

		MIN	MAX	UNIT
V <sub>CC</sub>	Supply voltage range	- 0.5	7	V
I <sub>IK</sub>	Input clamp current <sup>(2)</sup>	V <sub>I</sub> < 0 or V <sub>I</sub> > V <sub>CC</sub>	±20	mA
I <sub>OK</sub>	Output clamp current <sup>(2)</sup>	V <sub>O</sub> < 0 or V <sub>O</sub> > V <sub>CC</sub>	±20	mA
I <sub>O</sub>	Continuous output current	V <sub>O</sub> = 0 to V <sub>CC</sub>	±25	mA
	Continuous current through V <sub>CC</sub> or GND		±50	mA
T <sub>J</sub>	Junction temperature		150	°C
T <sub>stg</sub>	Storage temperature	- 65	150	°C

- (1) Stresses beyond those listed under *absolute maximum ratings* may cause permanent damage to the device. These are stress ratings only and functional operation of the device at these or any other conditions beyond those indicated under [§ 5.2](#) is not implied. Exposure to absolute-maximum-rated conditions for extended periods may affect device reliability.
- (2) The input and output voltage ratings may be exceeded if the input and output current ratings are observed.

### 5.2 Recommended Operating Conditions<sup>(1)</sup>

		SN54HC259			SN74HC259			UNIT
		MIN	NOM	MAX	MIN	NOM	MAX	
V <sub>CC</sub>	Supply voltage	2	5	6	2	5	6	V
V <sub>IH</sub>	High-level input voltage	V <sub>CC</sub> = 2 V	1.5		1.5			V
		V <sub>CC</sub> = 4.5 V	3.15		3.15			
		V <sub>CC</sub> = 6 V	4.2		4.2			
V <sub>IL</sub>	Low-level input voltage	V <sub>CC</sub> = 2 V		0.5		0.5		V
		V <sub>CC</sub> = 4.5 V		1.35		1.35		
		V <sub>CC</sub> = 6 V		1.8		1.8		
V <sub>I</sub>	Input voltage	0		V <sub>CC</sub>	0		V <sub>CC</sub>	V
V <sub>O</sub>	Output voltage	0		V <sub>CC</sub>	0		V <sub>CC</sub>	V
t <sub>t</sub>	Input transition rise/fall time	V <sub>CC</sub> = 2 V		1000		1000		ns
		V <sub>CC</sub> = 4.5 V		500		500		
		V <sub>CC</sub> = 6 V		400		400		
T <sub>A</sub>	Operating free-air temperature	-55		125	-40		85	°C

- (1) All unused inputs of the device must be held at V<sub>CC</sub> or GND to ensure proper device operation. Refer to the TI application report, *Implications of Slow or Floating CMOS Inputs*, literature number [SCBA004](#).

### 5.3 Thermal Information

THERMAL METRIC		D (SOIC)	N (PDIP)	NS (SO)	PW (TSSOP)	UNIT
		16 PINS	16 PINS	16 PINS	16 PINS	
R <sub>θJA</sub>	Junction-to-ambient thermal resistance <sup>(1)</sup>	73	67	64	108	°C/W

- (1) For more information about traditional and new thermal metrics, see the [Semiconductor and IC package thermal metrics](#) application report.

## 5.4 Electrical Characteristics

over recommended operating free-air temperature range (unless otherwise noted)

PARAMETER	TEST CONDITIONS <sup>(1)</sup>	V <sub>CC</sub> (V)	T <sub>A</sub> = 25°C			SN54HC259		SN74HC259		UNIT
			MIN	TYP	MAX	MIN	MAX	MIN	MAX	
V <sub>OH</sub>	I <sub>OH</sub> = -20 μA	2	1.9	1.998		1.9		1.9	V	
		4.5	4.4	4.499		4.4		4.4		
		6	5.9	5.999		5.9		5.9		
	I <sub>OH</sub> = -4 mA	4.5	3.98	4.3		3.7		3.84		
	I <sub>OH</sub> = -5.2 mA	6	5.48	5.8		5.2		5.34		
V <sub>OL</sub>	I <sub>OL</sub> = 20 μA	2		0.002	0.1		0.1	0.1	V	
		4.5		0.001	0.1		0.1	0.1		
		6		0.001	0.1		0.1	0.1		
	I <sub>OL</sub> = 4 mA	4.5		0.17	0.26		0.4	0.33		
	I <sub>OL</sub> = 5.2 mA	6		0.15	0.26		0.4	0.33		
I <sub>I</sub>	V <sub>I</sub> = V <sub>CC</sub> or 0	6		±0.1	±100		±1000	±1000	nA	
I <sub>CC</sub>	V <sub>I</sub> = V <sub>CC</sub> or 0, I <sub>O</sub> = 0	6			8		160	80	μA	
C <sub>i</sub>		2 to 6		3	10		10	10	pF	

(1) V<sub>I</sub> = V<sub>IH</sub> or V<sub>IL</sub>, unless otherwise noted.

## 5.5 Timing Requirements

over recommended operating free-air temperature range (unless otherwise noted)

		V <sub>CC</sub> (V)	T <sub>A</sub> = 25°C		SN54HC259		SN74HC259		UNIT
			MIN	MAX	MIN	MAX	MIN	MAX	
t <sub>w</sub>	Pulse duration	CLR low	2	80		120		100	ns
			4.5	16		24		20	
			6	14		20		17	
		G low	2	80		120		100	
			4.5	16		24		20	
			6	14		20		17	
t <sub>su</sub>	Setup time, data or address before G ↑	2	75		115		95	ns	
		4.5	15		23		19		
		6	13		20		16		
t <sub>h</sub>	Hold time, data or address after GG ↑	2	5		5		5	ns	
		4.5	5		5		5		
		6	5		5		5		

## 5.6 Switching Characteristics

over recommended operating free-air temperature range,  $C_L = 50$  pF (unless otherwise noted) (see [Parameter Measurement Information](#))

PARAMETER	FROM (INPUT)	TO (OUTPUT)	$V_{CC}$ (V)	$T_A = 25^\circ\text{C}$			SN54HC259		SN74HC259		UNIT
				MIN	TYP	MAX	MIN	MAX	MIN	MAX	
$t_{PHL}$	$\overline{CLR}$	Any Q	2	60	150	225	190	ns			
			4.5	18	30	45	38				
			6	14	26	38	32				
$t_{pd}$	Data	Any Q	2	56	130	195	165	ns			
			4.5	17	26	39	33				
			6	13	22	33	28				
	Address	Any Q	2	74	200	300	250				
			4.5	21	40	60	50				
			6	17	34	51	43				
	$\overline{G}$	Any Q	2	66	170	255	215				
			4.5	20	34	51	43				
			6	16	29	43	37				
$t_t$	Any	Any	2	28	75	110	95	ns			
			4.5	8	15	22	19				
			6	6	13	19	16				

## 5.7 Operating Characteristics

$T_A = 25^\circ\text{C}$

PARAMETER	TEST CONDITIONS	TYP	UNIT
$C_{pd}$	Power dissipation capacitance per latch	33	pF

## 6 Parameter Measurement Information

Phase relationships between waveforms were chosen arbitrarily. All input pulses are supplied by generators having the following characteristics:  $PRR \leq 1 \text{ MHz}$ ,  $Z_O = 50 \Omega$ ,  $t_t < 6 \text{ ns}$ .

For clock inputs,  $f_{\text{max}}$  is measured when the input duty cycle is 50%.

The outputs are measured one at a time with one input transition per measurement.

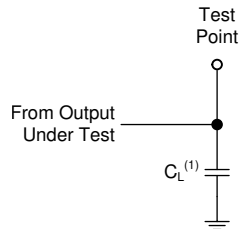

(1)  $C_L$  includes probe and test-fixture capacitance.

图 6-1. Load Circuit for Push-Pull Outputs

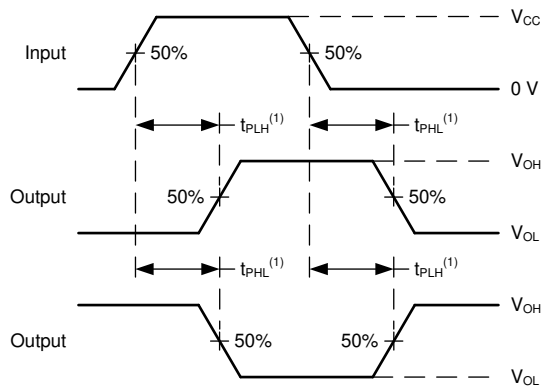

(1) The greater between  $t_{pLH}$  and  $t_{pHL}$  is the same as  $t_{pd}$ .

图 6-2. Voltage Waveforms, Propagation Delays for Standard CMOS Inputs

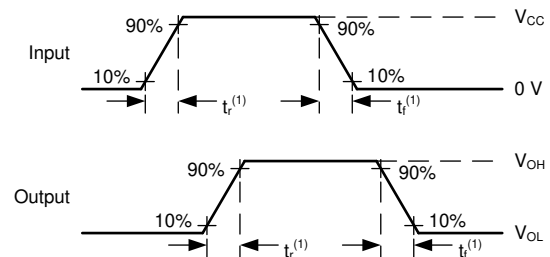

(1) The greater between  $t_r$  and  $t_f$  is the same as  $t_t$ .

图 6-3. Voltage Waveforms, Input and Output Transition Times for Standard CMOS Inputs

## 7 Detailed Description

### 7.1 Overview

These 8-bit addressable latches are designed for general-purpose storage applications in digital systems. Specific uses include working registers, serial-holding registers, and active-high decoders or demultiplexers. They are multifunctional devices capable of storing single-line data in eight addressable latches and being a 1-of-8 decoder or demultiplexer with active-high outputs.

Four distinct modes of operation are selectable by controlling the clear ( $\overline{\text{CLR}}$ ) and enable ( $\overline{\text{G}}$ ) inputs. In the addressable-latch mode, data at the data-in terminal is written into the addressed latch. The addressed latch follows the data input, with all unaddressed latches remaining in their previous states. In the memory mode, all latches remain in their previous states and are unaffected by the data or address inputs. To eliminate the possibility of entering erroneous data in the latches,  $\overline{\text{G}}$  should be held high (inactive) while the address lines are changing. In the 1-of-8 decoding or demultiplexing mode, the addressed output follows the level of the D input with all other outputs low. In the clear mode, all outputs are low and unaffected by the address and data inputs.

### 7.2 Functional Block Diagram

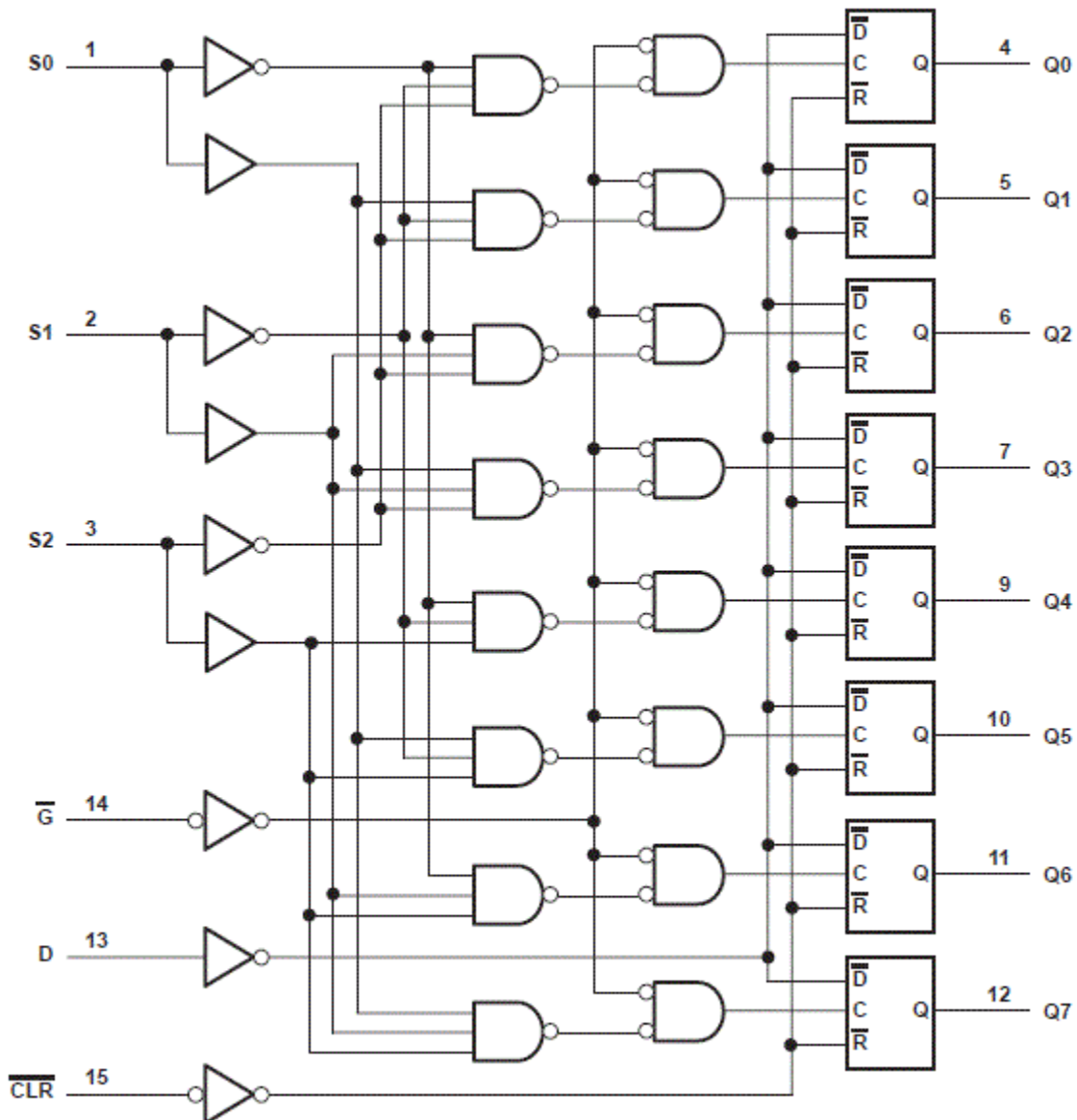

Pin numbers shown are for the D, J, N, NS, PW, and W packages.



图 7-1. Logic Diagram, Each Internal Latch (positive logic)

### 7.3 Device Functional Modes

表 7-1. Function Table

INPUTS		OUTPUT OF ADDRESSED LATCH	EACH OTHER OUTPUT	FUNCTION
CLR	G			
H	L	D	$Q_{iO}$	Addressable latch
H	H	$Q_{iO}$	$Q_{iO}$	Memory
L	L	D	L	8-line demultiplexer
L	H	L	L	Clear

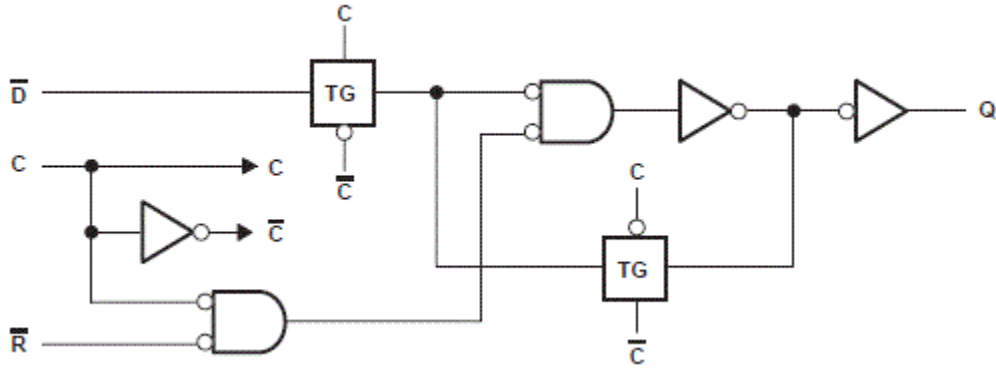
表 7-2. Latch Selection Table

SELECT INPUTS			LATCH ADDRESSED
S2	S1	S0	
L	L	L	0
L	L	H	1
L	H	L	2
L	H	H	3
H	L	L	4
H	L	H	5
H	H	L	6
H	H	H	7

## 8 Power Supply Recommendations

The power supply can be any voltage between the minimum and maximum supply voltage rating located in the *Recommended Operating Conditions*. Each  $V_{CC}$  terminal should have a good bypass capacitor to prevent power disturbance. A 0.1- $\mu$ F capacitor is recommended for this device. It is acceptable to parallel multiple bypass caps to reject different frequencies of noise. The 0.1- $\mu$ F and 1- $\mu$ F capacitors are commonly used in parallel. The bypass capacitor should be installed as close to the power terminal as possible for best results.

## 9 Layout

### 9.1 Layout Guidelines

When using multiple-input and multiple-channel logic devices inputs must not ever be left floating. In many cases, functions or parts of functions of digital logic devices are unused; for example, when only two inputs of a triple-input AND gate are used or only 3 of the 4 buffer gates are used. Such unused input pins must not be left unconnected because the undefined voltages at the outside connections result in undefined operational states. All unused inputs of digital logic devices must be connected to a logic high or logic low voltage, as defined by the input voltage specifications, to prevent them from floating. The logic level that must be applied to any particular unused input depends on the function of the device. Generally, the inputs are tied to GND or  $V_{CC}$ , whichever makes more sense for the logic function or is more convenient.

## 10 Device and Documentation Support

TI offers an extensive line of development tools. Tools and software to evaluate the performance of the device, generate code, and develop solutions are listed below.

### 10.1 接收文档更新通知

要接收文档更新通知，请导航至 [ti.com](http://ti.com) 上的器件产品文件夹。点击 [订阅更新](#) 进行注册，即可每周接收产品信息更改摘要。有关更改的详细信息，请查看任何已修订文档中包含的修订历史记录。

### 10.2 支持资源

[TI E2E™ 支持论坛](#) 是工程师的重要参考资料，可直接从专家获得快速、经过验证的解答和设计帮助。搜索现有解答或提出自己的问题可获得所需的快速设计帮助。

链接的内容由各个贡献者“按原样”提供。这些内容并不构成 TI 技术规范，并且不一定反映 TI 的观点；请参阅 TI 的 [《使用条款》](#)。

### 10.3 Trademarks

TI E2E™ is a trademark of Texas Instruments.

所有商标均为其各自所有者的财产。

### 10.4 Electrostatic Discharge Caution



This integrated circuit can be damaged by ESD. Texas Instruments recommends that all integrated circuits be handled with appropriate precautions. Failure to observe proper handling and installation procedures can cause damage.

ESD damage can range from subtle performance degradation to complete device failure. Precision integrated circuits may be more susceptible to damage because very small parametric changes could cause the device not to meet its published specifications.

### 10.5 术语表

[TI 术语表](#) 本术语表列出并解释了术语、首字母缩略词和定义。

## 11 Mechanical, Packaging, and Orderable Information

The following pages include mechanical, packaging, and orderable information. This information is the most current data available for the designated devices. This data is subject to change without notice and revision of this document. For browser-based versions of this data sheet, refer to the left-hand navigation.

## 重要声明和免责声明

TI 提供技术和可靠性数据 (包括数据表)、设计资源 (包括参考设计)、应用或其他设计建议、网络工具、安全信息和其他资源, 不保证没有瑕疵且不做任何明示或暗示的担保, 包括但不限于对适销性、某特定用途方面的适用性或不侵犯任何第三方知识产权的暗示担保。

这些资源可供使用 TI 产品进行设计的熟练开发人员使用。您将自行承担以下全部责任: (1) 针对您的应用选择合适的 TI 产品, (2) 设计、验证并测试您的应用, (3) 确保您的应用满足相应标准以及任何其他安全、安保或其他要求。这些资源如有变更, 恕不另行通知。TI 授权您仅可将这些资源用于研发本资源所述的 TI 产品的应用。严禁对这些资源进行其他复制或展示。您无权使用任何其他 TI 知识产权或任何第三方知识产权。您应全额赔偿因在这些资源的使用中对 TI 及其代表造成的任何索赔、损害、成本、损失和债务, TI 对此概不负责。

TI 提供的产品受 TI 的销售条款 (<https://www.ti.com/legal/termsofsale.html>) 或 [ti.com](https://www.ti.com) 上其他适用条款/TI 产品随附的其他适用条款的约束。TI 提供这些资源并不会扩展或以其他方式更改 TI 针对 TI 产品发布的适用的担保或担保免责声明。

邮寄地址: Texas Instruments, Post Office Box 655303, Dallas, Texas 75265

Copyright © 2021, 德州仪器 (TI) 公司

**PACKAGING INFORMATION**

Orderable part number	Status (1)	Material type (2)	Package   Pins	Package qty   Carrier	RoHS (3)	Lead finish/ Ball material (4)	MSL rating/ Peak reflow (5)	Op temp (°C)	Part marking (6)
<a href="#">85519012A</a>	Active	Production	LCCC (FK)   20	55   TUBE	No	SNPB	N/A for Pkg Type	-55 to 125	85519012A SNJ54HC 259FK
<a href="#">8551901EA</a>	Active	Production	CDIP (J)   16	25   TUBE	No	SNPB	N/A for Pkg Type	-55 to 125	8551901EA SNJ54HC259J
<a href="#">JM38510/65402BEA</a>	Active	Production	CDIP (J)   16	25   TUBE	No	SNPB	N/A for Pkg Type	-55 to 125	JM38510/ 65402BEA
JM38510/65402BEA.A	Active	Production	CDIP (J)   16	25   TUBE	No	SNPB	N/A for Pkg Type	-55 to 125	JM38510/ 65402BEA
<a href="#">M38510/65402BEA</a>	Active	Production	CDIP (J)   16	25   TUBE	No	SNPB	N/A for Pkg Type	-55 to 125	JM38510/ 65402BEA
<a href="#">SN54HC259J</a>	Active	Production	CDIP (J)   16	25   TUBE	No	SNPB	N/A for Pkg Type	-55 to 125	SN54HC259J
SN54HC259J.A	Active	Production	CDIP (J)   16	25   TUBE	No	SNPB	N/A for Pkg Type	-55 to 125	SN54HC259J
<a href="#">SN74HC259D</a>	Obsolete	Production	SOIC (D)   16	-	-	Call TI	Call TI	-40 to 85	HC259
<a href="#">SN74HC259DR</a>	Active	Production	SOIC (D)   16	2500   LARGE T&R	Yes	NIPDAU   SN	Level-1-260C-UNLIM	-40 to 85	HC259
SN74HC259DR.A	Active	Production	SOIC (D)   16	2500   LARGE T&R	Yes	NIPDAU	Level-1-260C-UNLIM	-40 to 85	HC259
SN74HC259DRE4	Active	Production	SOIC (D)   16	2500   LARGE T&R	Yes	NIPDAU	Level-1-260C-UNLIM	-40 to 85	HC259
<a href="#">SN74HC259DRG4</a>	Active	Production	SOIC (D)   16	2500   LARGE T&R	Yes	NIPDAU	Level-1-260C-UNLIM	-40 to 85	HC259
SN74HC259DRG4.A	Active	Production	SOIC (D)   16	2500   LARGE T&R	Yes	NIPDAU	Level-1-260C-UNLIM	-40 to 85	HC259
<a href="#">SN74HC259DT</a>	Obsolete	Production	SOIC (D)   16	-	-	Call TI	Call TI	-40 to 85	HC259
<a href="#">SN74HC259N</a>	Active	Production	PDIP (N)   16	25   TUBE	Yes	NIPDAU	N/A for Pkg Type	-40 to 85	SN74HC259N
SN74HC259N.A	Active	Production	PDIP (N)   16	25   TUBE	Yes	NIPDAU	N/A for Pkg Type	-40 to 85	SN74HC259N
SN74HC259NE4	Active	Production	PDIP (N)   16	25   TUBE	Yes	NIPDAU	N/A for Pkg Type	-40 to 85	SN74HC259N
<a href="#">SN74HC259NSR</a>	Active	Production	SOP (NS)   16	2000   LARGE T&R	Yes	NIPDAU	Level-1-260C-UNLIM	-40 to 85	HC259
SN74HC259NSR.A	Active	Production	SOP (NS)   16	2000   LARGE T&R	Yes	NIPDAU	Level-1-260C-UNLIM	-40 to 85	HC259
<a href="#">SN74HC259PWR</a>	Active	Production	TSSOP (PW)   16	2000   LARGE T&R	Yes	NIPDAU   SN	Level-1-260C-UNLIM	-40 to 85	HC259
SN74HC259PWR.A	Active	Production	TSSOP (PW)   16	2000   LARGE T&R	Yes	NIPDAU	Level-1-260C-UNLIM	-40 to 85	HC259
<a href="#">SN74HC259PWRG4</a>	Active	Production	TSSOP (PW)   16	2000   LARGE T&R	Yes	NIPDAU	Level-1-260C-UNLIM	-40 to 85	HC259
<a href="#">SN74HC259PWT</a>	Obsolete	Production	TSSOP (PW)   16	-	-	Call TI	Call TI	-40 to 85	HC259
<a href="#">SN74HCS259DYYR</a>	Active	Production	SOT-23-THIN (DYY)   16	3000   LARGE T&R	Yes	NIPDAU	Level-1-260C-UNLIM	-40 to 125	HCS259

Orderable part number	Status (1)	Material type (2)	Package   Pins	Package qty   Carrier	RoHS (3)	Lead finish/ Ball material (4)	MSL rating/ Peak reflow (5)	Op temp (°C)	Part marking (6)
SN74HCS259DYYR.A	Active	Production	SOT-23-THIN (DYY)   16	3000   LARGE T&R	Yes	NIPDAU	Level-1-260C-UNLIM	-40 to 125	HCS259
<a href="#">SNJ54HC259FK</a>	Active	Production	LCCC (FK)   20	55   TUBE	No	SNPB	N/A for Pkg Type	-55 to 125	85519012A SNJ54HC 259FK
SNJ54HC259FK.A	Active	Production	LCCC (FK)   20	55   TUBE	No	SNPB	N/A for Pkg Type	-55 to 125	85519012A SNJ54HC 259FK
<a href="#">SNJ54HC259J</a>	Active	Production	CDIP (J)   16	25   TUBE	No	SNPB	N/A for Pkg Type	-55 to 125	8551901EA SNJ54HC259J
SNJ54HC259J.A	Active	Production	CDIP (J)   16	25   TUBE	No	SNPB	N/A for Pkg Type	-55 to 125	8551901EA SNJ54HC259J

<sup>(1)</sup> **Status:** For more details on status, see our [product life cycle](#).

<sup>(2)</sup> **Material type:** When designated, preproduction parts are prototypes/experimental devices, and are not yet approved or released for full production. Testing and final process, including without limitation quality assurance, reliability performance testing, and/or process qualification, may not yet be complete, and this item is subject to further changes or possible discontinuation. If available for ordering, purchases will be subject to an additional waiver at checkout, and are intended for early internal evaluation purposes only. These items are sold without warranties of any kind.

<sup>(3)</sup> **RoHS values:** Yes, No, RoHS Exempt. See the [TI RoHS Statement](#) for additional information and value definition.

<sup>(4)</sup> **Lead finish/Ball material:** Parts may have multiple material finish options. Finish options are separated by a vertical ruled line. Lead finish/Ball material values may wrap to two lines if the finish value exceeds the maximum column width.

<sup>(5)</sup> **MSL rating/Peak reflow:** The moisture sensitivity level ratings and peak solder (reflow) temperatures. In the event that a part has multiple moisture sensitivity ratings, only the lowest level per JEDEC standards is shown. Refer to the shipping label for the actual reflow temperature that will be used to mount the part to the printed circuit board.

<sup>(6)</sup> **Part marking:** There may be an additional marking, which relates to the logo, the lot trace code information, or the environmental category of the part.

Multiple part markings will be inside parentheses. Only one part marking contained in parentheses and separated by a "-" will appear on a part. If a line is indented then it is a continuation of the previous line and the two combined represent the entire part marking for that device.

**Important Information and Disclaimer:** The information provided on this page represents TI's knowledge and belief as of the date that it is provided. TI bases its knowledge and belief on information provided by third parties, and makes no representation or warranty as to the accuracy of such information. Efforts are underway to better integrate information from third parties. TI has taken and continues to take reasonable steps to provide representative and accurate information but may not have conducted destructive testing or chemical analysis on incoming materials and chemicals. TI and TI suppliers consider certain information to be proprietary, and thus CAS numbers and other limited information may not be available for release.

In no event shall TI's liability arising out of such information exceed the total purchase price of the TI part(s) at issue in this document sold by TI to Customer on an annual basis.

**OTHER QUALIFIED VERSIONS OF SN54HC259, SN74HC259 :**

- Catalog : [SN74HC259](#)
- Military : [SN54HC259](#)

NOTE: Qualified Version Definitions:

- Catalog - TI's standard catalog product
- Military - QML certified for Military and Defense Applications

**TAPE AND REEL INFORMATION**

**QUADRANT ASSIGNMENTS FOR PIN 1 ORIENTATION IN TAPE**

\*All dimensions are nominal

Device	Package Type	Package Drawing	Pins	SPQ	Reel Diameter (mm)	Reel Width W1 (mm)	A0 (mm)	B0 (mm)	K0 (mm)	P1 (mm)	W (mm)	Pin1 Quadrant
SN74HC259DR	SOIC	D	16	2500	330.0	16.4	6.5	10.3	2.1	8.0	16.0	Q1
SN74HC259DR	SOIC	D	16	2500	330.0	16.4	6.5	10.3	2.1	8.0	16.0	Q1
SN74HC259DRG4	SOIC	D	16	2500	330.0	16.4	6.5	10.3	2.1	8.0	16.0	Q1
SN74HC259DRG4	SOIC	D	16	2500	330.0	16.4	6.5	10.3	2.1	8.0	16.0	Q1
SN74HC259NSR	SOP	NS	16	2000	330.0	16.4	8.1	10.4	2.5	12.0	16.0	Q1
SN74HC259PWR	TSSOP	PW	16	2000	330.0	12.4	6.9	5.6	1.6	8.0	12.0	Q1
SN74HC259PWRG4	TSSOP	PW	16	2000	330.0	12.4	6.9	5.6	1.6	8.0	12.0	Q1
SN74HCS259DYYR	SOT-23-THIN	DYY	16	3000	330.0	12.4	4.8	3.6	1.6	8.0	12.0	Q3

## TAPE AND REEL BOX DIMENSIONS



\*All dimensions are nominal

Device	Package Type	Package Drawing	Pins	SPQ	Length (mm)	Width (mm)	Height (mm)
SN74HC259DR	SOIC	D	16	2500	340.5	336.1	32.0
SN74HC259DR	SOIC	D	16	2500	340.5	336.1	32.0
SN74HC259DRG4	SOIC	D	16	2500	353.0	353.0	32.0
SN74HC259DRG4	SOIC	D	16	2500	353.0	353.0	32.0
SN74HC259NSR	SOP	NS	16	2000	353.0	353.0	32.0
SN74HC259PWR	TSSOP	PW	16	2000	356.0	356.0	35.0
SN74HC259PWRG4	TSSOP	PW	16	2000	356.0	356.0	35.0
SN74HCS259DYYR	SOT-23-THIN	DYY	16	3000	336.6	336.6	31.8

**TUBE**

\*All dimensions are nominal

Device	Package Name	Package Type	Pins	SPQ	L (mm)	W (mm)	T (μm)	B (mm)
85519012A	FK	LCCC	20	55	506.98	12.06	2030	NA
SN74HC259N	N	PDIP	16	25	506	13.97	11230	4.32
SN74HC259N	N	PDIP	16	25	506	13.97	11230	4.32
SN74HC259N.A	N	PDIP	16	25	506	13.97	11230	4.32
SN74HC259N.A	N	PDIP	16	25	506	13.97	11230	4.32
SN74HC259NE4	N	PDIP	16	25	506	13.97	11230	4.32
SN74HC259NE4	N	PDIP	16	25	506	13.97	11230	4.32
SNJ54HC259FK	FK	LCCC	20	55	506.98	12.06	2030	NA
SNJ54HC259FK.A	FK	LCCC	20	55	506.98	12.06	2030	NA

## GENERIC PACKAGE VIEW

**FK 20**

**LCCC - 2.03 mm max height**

8.89 x 8.89, 1.27 mm pitch

LEADLESS CERAMIC CHIP CARRIER

This image is a representation of the package family, actual package may vary.  
Refer to the product data sheet for package details.



4229370VA\

J (R-GDIP-T\*\*)

14 LEADS SHOWN

CERAMIC DUAL IN-LINE PACKAGE



DIM \ PINS **	14	16	18	20
A	0.300 (7,62) BSC	0.300 (7,62) BSC	0.300 (7,62) BSC	0.300 (7,62) BSC
B MAX	0.785 (19,94)	.840 (21,34)	0.960 (24,38)	1.060 (26,92)
B MIN	—	—	—	—
C MAX	0.300 (7,62)	0.300 (7,62)	0.310 (7,87)	0.300 (7,62)
C MIN	0.245 (6,22)	0.245 (6,22)	0.220 (5,59)	0.245 (6,22)



4040083/F 03/03

- NOTES:
- All linear dimensions are in inches (millimeters).
  - This drawing is subject to change without notice.
  - This package is hermetically sealed with a ceramic lid using glass frit.
  - Index point is provided on cap for terminal identification only on press ceramic glass frit seal only.
  - Falls within MIL STD 1835 GDIP1-T14, GDIP1-T16, GDIP1-T18 and GDIP1-T20.



NOTES:

1. All linear dimensions are in millimeters. Any dimensions in parenthesis are for reference only. Dimensioning and tolerancing per ASME Y14.5M.
2. This drawing is subject to change without notice.
3. This dimension does not include mold flash, protrusions, or gate burrs. Mold flash, protrusions, or gate burrs shall not exceed 0.15 mm per side.
4. This dimension does not include interlead flash. Interlead flash shall not exceed 0.25 mm per side.
5. Reference JEDEC registration MO-153.

# EXAMPLE BOARD LAYOUT

PW0016A

TSSOP - 1.2 mm max height

SMALL OUTLINE PACKAGE

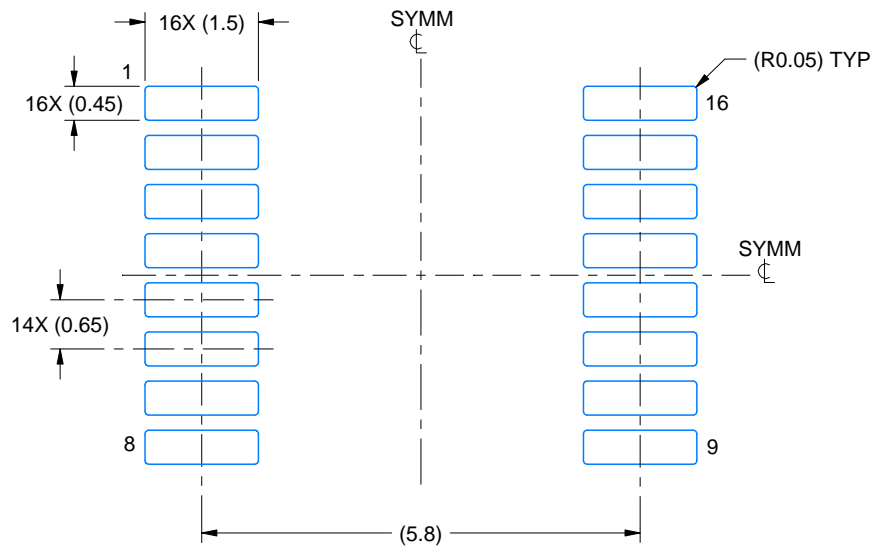

LAND PATTERN EXAMPLE  
EXPOSED METAL SHOWN  
SCALE: 10X



SOLDER MASK DETAILS

4220204/B 12/2023

NOTES: (continued)

- 6. Publication IPC-7351 may have alternate designs.
- 7. Solder mask tolerances between and around signal pads can vary based on board fabrication site.

# EXAMPLE STENCIL DESIGN

PW0016A

TSSOP - 1.2 mm max height

SMALL OUTLINE PACKAGE



SOLDER PASTE EXAMPLE  
BASED ON 0.125 mm THICK STENCIL  
SCALE: 10X

4220204/B 12/2023

NOTES: (continued)

8. Laser cutting apertures with trapezoidal walls and rounded corners may offer better paste release. IPC-7525 may have alternate design recommendations.
9. Board assembly site may have different recommendations for stencil design.

N (R-PDIP-T\*\*)

PLASTIC DUAL-IN-LINE PACKAGE

16 PINS SHOWN



- NOTES:
- A. All linear dimensions are in inches (millimeters).
  - B. This drawing is subject to change without notice.
  - Falls within JEDEC MS-001, except 18 and 20 pin minimum body length (Dim A).
  - The 20 pin end lead shoulder width is a vendor option, either half or full width.



# PACKAGE OUTLINE

## NS0016A

### SOP - 2.00 mm max height

SOP



#### NOTES:

1. All linear dimensions are in millimeters. Dimensions in parenthesis are for reference only. Dimensioning and tolerancing per ASME Y14.5M.
2. This drawing is subject to change without notice.
3. This dimension does not include mold flash, protrusions, or gate burrs. Mold flash, protrusions, or gate burrs shall not exceed 0.15 mm, per side.
4. This dimension does not include interlead flash. Interlead flash shall not exceed 0.25 mm, per side.

# EXAMPLE BOARD LAYOUT

NS0016A

SOP - 2.00 mm max height

SOP



4220735/A 12/2021

NOTES: (continued)

5. Publication IPC-7351 may have alternate designs.

6. Solder mask tolerances between and around signal pads can vary based on board fabrication site.

# EXAMPLE STENCIL DESIGN

NS0016A

SOP - 2.00 mm max height

SOP



SOLDER PASTE EXAMPLE  
BASED ON 0.125 mm THICK STENCIL  
SCALE:7X

4220735/A 12/2021

NOTES: (continued)

7. Laser cutting apertures with trapezoidal walls and rounded corners may offer better paste release. IPC-7525 may have alternate design recommendations.
8. Board assembly site may have different recommendations for stencil design.

D (R-PDSO-G16)

PLASTIC SMALL OUTLINE



- NOTES:
- A. All linear dimensions are in inches (millimeters).
  - B. This drawing is subject to change without notice.
  - C. Body length does not include mold flash, protrusions, or gate burrs. Mold flash, protrusions, or gate burrs shall not exceed 0.006 (0,15) each side.
  - D. Body width does not include interlead flash. Interlead flash shall not exceed 0.017 (0,43) each side.
  - E. Reference JEDEC MS-012 variation AC.

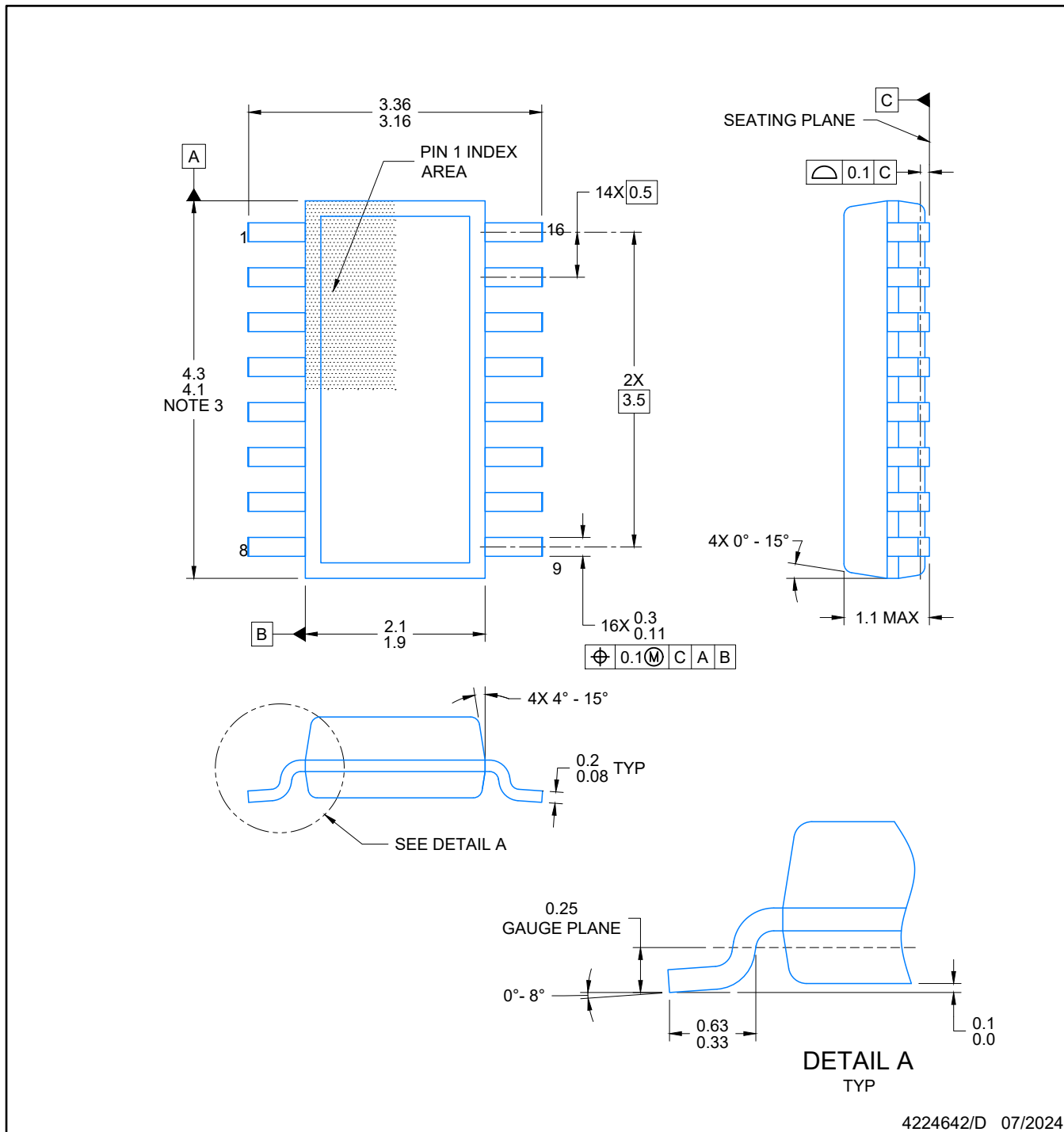

4224642/D 07/2024

NOTES:

1. All linear dimensions are in millimeters. Any dimensions in parenthesis are for reference only. Dimensioning and tolerancing per ASME Y14.5M.
2. This drawing is subject to change without notice.
3. This dimension does not include mold flash, protrusions, or gate burrs. Mold flash, protrusions, or gate burrs shall not exceed 0.15 per side.
4. This dimension does not include interlead flash. Interlead flash shall not exceed 0.50 per side.
5. Reference JEDEC Registration MO-345, Variation AA

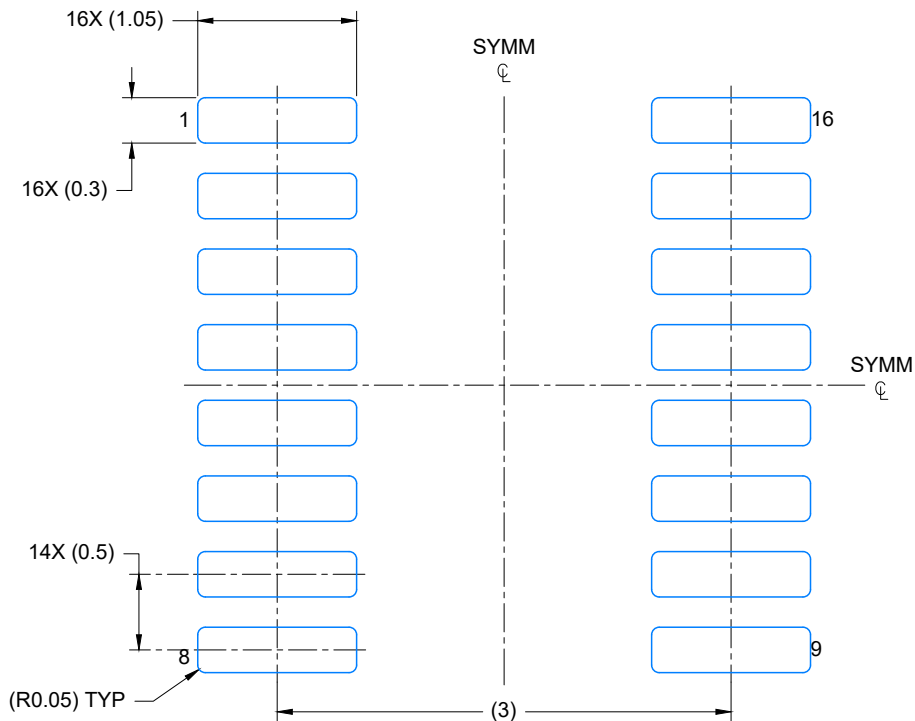

LAND PATTERN EXAMPLE  
EXPOSED METAL SHOWN  
SCALE: 20X

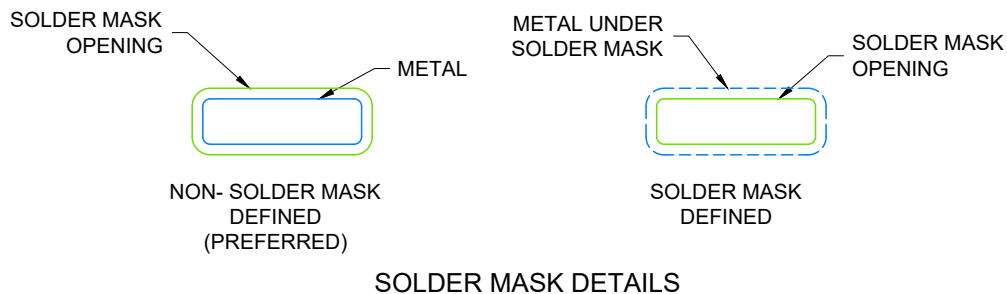

4224642/D 07/2024

NOTES: (continued)

- 6. Publication IPC-7351 may have alternate designs.
- 7. Solder mask tolerances between and around signal pads can vary based on board fabrication site.

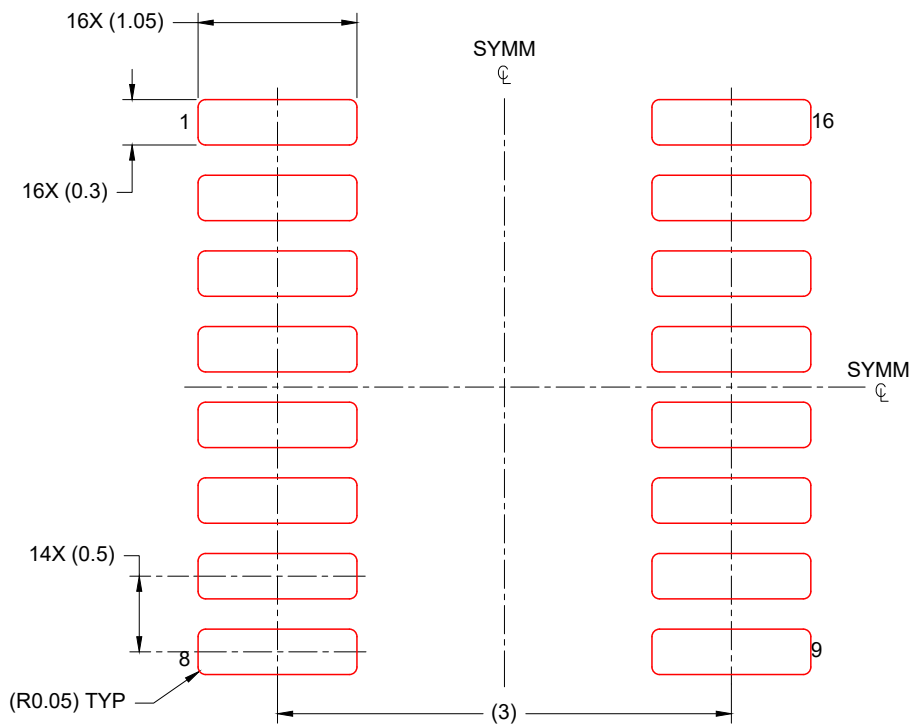

SOLDER PASTE EXAMPLE  
BASED ON 0.125 mm THICK STENCIL  
SCALE: 20X

4224642/D 07/2024

NOTES: (continued)

- 8. Laser cutting apertures with trapezoidal walls and rounded corners may offer better paste release. IPC-7525 may have alternate design recommendations.
- 9. Board assembly site may have different recommendations for stencil design.

## 重要通知和免责声明

TI“按原样”提供技术和可靠性数据（包括数据表）、设计资源（包括参考设计）、应用或其他设计建议、网络工具、安全信息和其他资源，不保证没有瑕疵且不做任何明示或暗示的担保，包括但不限于对适销性、与某特定用途的适用性或不侵犯任何第三方知识产权的暗示担保。

这些资源可供使用 TI 产品进行设计的熟练开发人员使用。您将自行承担以下全部责任：(1) 针对您的应用选择合适的 TI 产品，(2) 设计、验证并测试您的应用，(3) 确保您的应用满足相应标准以及任何其他安全、安保法规或其他要求。

这些资源如有变更，恕不另行通知。TI 授权您仅可将这些资源用于研发本资源所述的 TI 产品的相关应用。严禁以其他方式对这些资源进行复制或展示。您无权使用任何其他 TI 知识产权或任何第三方知识产权。对于因您对这些资源的使用而对 TI 及其代表造成的任何索赔、损害、成本、损失和债务，您将全额赔偿，TI 对此概不负责。

TI 提供的产品受 [TI 销售条款](#)、[TI 通用质量指南](#) 或 [ti.com](#) 上其他适用条款或 TI 产品随附的其他适用条款的约束。TI 提供这些资源并不会扩展或以其他方式更改 TI 针对 TI 产品发布的适用的担保或担保免责声明。除非德州仪器 (TI) 明确将某产品指定为定制产品或客户特定产品，否则其产品均为按确定价格收入目录的标准通用器件。

TI 反对并拒绝您可能提出的任何其他或不同的条款。

版权所有 © 2026，德州仪器 (TI) 公司

最后更新日期：2025 年 10 月