

具有集成 ESD 保护的 TCA8418 I²C 控制型键盘扫描 IC

1 特性

- 工作电源电压范围：1.65V 至 3.6V
- 可借助 18 个通用输入输出 (GPIO) 支持 80 个按钮
- 支持 QWERTY 键盘操作和通用输入输出 (GPIO) 扩展
- 低待机（空闲）电流消耗：3 μ A
- 支持 1MHz 快速模式加上 I²C 总线
- 10 字节先入先出 (FIFO) 可存储 10 次按键按压和释放操作
- 开漏电路低电平有效中断输出
- 集成消抖时间为 50 μ s
- 施密特触发器操作可在 SCL 和 SDA 输入端实现缓慢输入转换和更好的开关噪声抗扰度：1.8V 时的 V_{hys} 典型值为 0.18V
- 锁断性能超过 200mA，符合 JESD 78 II 类规范的要求
- 全部 18 个 GPIO 引脚和非 GPIO 引脚上的 ESD 保护均超出 JESD 22 规范要求
 - 2000V 人体放电模型 (A114-A)
 - 1000V 器件充电模型 (C101)

2 应用范围

- 智能电话
- 平板电脑
- 人机界面 (HMI) 面板
- 全球卫星定位 (GPS) 设备
- MP3 播放器
- 数码照相机

3 说明

TCA8418 是一款具有集成 ESD 保护的键盘扫描器件。它能够在 1.65V 至 3.6V 电源电压下运行，具有 18 个 GPIO。这些 GPIO 可通过 I²C 接口支持多达 80 个按键。

按键控制器可对输入进行消抖以及保持用于存储按键按压和释放心事件的 10 字节 FIFO。该 FIFO 借助溢出绕回功能可存储多达 10 个按键事件。中断 (\overline{INT}) 输出可配置为在发生按键按压和按键释放心事件时，或这些事件达到最大速率时报警。

器件信息⁽¹⁾

器件型号	封装	封装尺寸 (标称值)
TCA8418	WQFN (24)	4.00mm x 4.00mm

(1) 如需了解所有可用封装，请参阅产品说明书末尾的可订购产品附录。

简化原理图

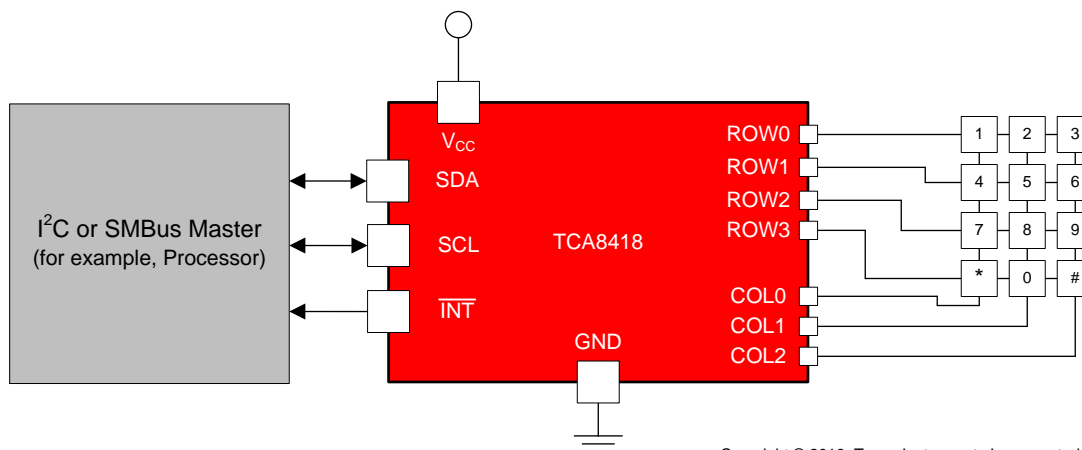

Copyright © 2016, Texas Instruments Incorporated

仅显示 7 个 GPIO (共 18 个)



目录

1	特性	1	8.2	Functional Block Diagram	15
2	应用范围	1	8.3	Feature Description	15
3	说明	1	8.4	Device Functional Modes	20
4	修订历史记录	2	8.5	Programming	21
5	Pin Configuration and Functions	3	8.6	Register Maps	25
6	Specifications	4	9	Application and Implementation	37
6.1	Absolute Maximum Ratings	4	9.1	Application Information	37
6.2	ESD Ratings	4	9.2	Typical Application	39
6.3	Recommended Operating Conditions	4	10	Power Supply Recommendations	42
6.4	Thermal Information	4	11	Layout	44
6.5	Electrical Characteristics	5	11.1	Layout Guidelines	44
6.6	I ² C Interface Timing Requirements	6	11.2	Layout Example	44
6.7	Reset Timing Requirements	6	12	器件和文档支持	45
6.8	Switching Characteristics	7	12.1	接收文档更新通知	45
6.9	Keypad Switching Characteristics	7	12.2	社区资源	45
6.10	Typical Characteristics	8	12.3	商标	45
7	Parameter Measurement Information	11	12.4	静电放电警告	45
8	Detailed Description	15	12.5	术语表	45
8.1	Overview	15	13	机械、封装和可订购信息	45

4 修订历史记录

注：之前版本的页码可能与当前版本有所不同。

Changes from Revision F (July 2017) to Revision G	Page
• Added sentence: " If debouncing is enabled, these registers return..." to GPIO Data Status Registers, GPIO_DAT_STAT1–3 (Address 0x14–0x16)	31

Changes from Revision E (November 2015) to Revision F	Page
• 将 WQFN 封装尺寸从“4.00mm × 3.00mm”更改为“4.00mm × 4.00mm”，删除了器件信息表中的 DSBGA (25) 封装	1

Changes from Revision D (July 2014) to Revision E	Page
• 已添加 ESD 额定值表，特性描述部分、器件功能模式、应用和实施部分、电源相关建议部分、布局部分、器件和文档支持部分以及机械、封装和可订购信息部分。	1
• Updated <i>Register Descriptions</i> table.	25

Changes from Revision B (March 2010) to Revision C	Page
• Added CAD Interrupt Errata section.	35
• Added Overflow Errata section.	36

5 Pin Configuration and Functions

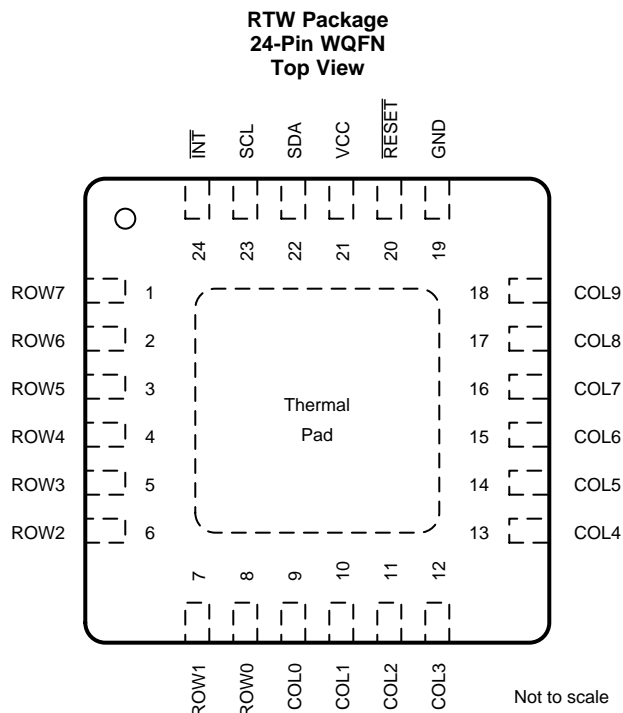

Pin Functions

PIN		TYPE	DESCRIPTION
No.	NAME		
1	ROW7	I/O	GPIO or row 7 in keypad matrix. If unused, connect to V_{CC} through a pull-up resistor.
2	ROW6	I/O	GPIO or row 6 in keypad matrix. If unused, connect to V_{CC} through a pull-up resistor.
3	ROW5	I/O	GPIO or row 5 in keypad matrix. If unused, connect to V_{CC} through a pull-up resistor.
4	ROW4	I/O	GPIO or row 4 in keypad matrix. If unused, connect to V_{CC} through a pull-up resistor.
5	ROW3	I/O	GPIO or row 3 in keypad matrix. If unused, connect to V_{CC} through a pull-up resistor.
6	ROW2	I/O	GPIO or row 2 in keypad matrix. If unused, connect to V_{CC} through a pull-up resistor.
7	ROW1	I/O	GPIO or row 1 in keypad matrix. If unused, connect to V_{CC} through a pull-up resistor.
8	ROW0	I/O	GPIO or row 0 in keypad matrix. If unused, connect to V_{CC} through a pull-up resistor.
9	COL0	I/O	GPIO or column 0 in keypad matrix. If unused, connect to V_{CC} through a pull-up resistor.
10	COL1	I/O	GPIO or column 1 in keypad matrix. If unused, connect to V_{CC} through a pull-up resistor.
11	COL2	I/O	GPIO or column 2 in keypad matrix. If unused, connect to V_{CC} through a pull-up resistor.
12	COL3	I/O	GPIO or column 3 in keypad matrix. If unused, connect to V_{CC} through a pull-up resistor.
13	COL4	I/O	GPIO or column 4 in keypad matrix. If unused, connect to V_{CC} through a pull-up resistor.
14	COL5	I/O	GPIO or column 5 in keypad matrix. If unused, connect to V_{CC} through a pull-up resistor.
15	COL6	I/O	GPIO or column 6 in keypad matrix. If unused, connect to V_{CC} through a pull-up resistor.
16	COL7	I/O	GPIO or column 7 in keypad matrix. If unused, connect to V_{CC} through a pull-up resistor.
17	COL8	I/O	GPIO or column 8 in keypad matrix. If unused, connect to V_{CC} through a pull-up resistor.
18	COL9	I/O	GPIO or column 9 in keypad matrix. If unused, connect to V_{CC} through a pull-up resistor.
19	GND	–	Ground
20	$\overline{\text{RESET}}$	I	Active-low reset input. Connect to V_{CC} through a pull-up resistor, if no active connection is used.
21	V_{CC}	-	Supply voltage of 1.65 V to 3.6 V
22	SDA	I/O	Serial data bus. Connect to V_{CC} through a pull-up resistor.
23	SCL	I	Serial clock bus. Connect to V_{CC} through a pull-up resistor.
24	$\overline{\text{INT}}$	O	Active-low interrupt output. Open drain structure. Connect to V_{CC} through a pull-up resistor.

6 Specifications

6.1 Absolute Maximum Ratings⁽¹⁾

over operating free-air temperature range (unless otherwise noted)

			MIN	MAX	UNIT
V _{CC}	Supply voltage range		-0.5	4.6	V
V _I	Input voltage range ⁽²⁾		-0.5	4.6	V
V _O	Voltage range applied to any output in the high-impedance or power-off state ⁽²⁾		-0.5	4.6	V
	Output voltage range in the high or low state ⁽²⁾		-0.5	4.6	
I _{IK}	Input clamp current	V _I < 0		±20	mA
I _{OK}	Output clamp current	V _O < 0		±20	mA
I _{OL}	Continuous output Low current	P port, SDA	V _O = 0 to V _{CC}	50	mA
		$\overline{\text{INT}}$		25	
I _{OH}	Continuous output High current	P port	V _O = 0 to V _{CC}	50	
T _{stg}	Storage temperature range		-65	150	°C

- (1) Stresses beyond those listed under *Absolute Maximum Ratings* may cause permanent damage to the device. These are stress ratings only, and functional operation of the device at these or any other conditions beyond those indicated under *Recommended Operating Conditions* is not implied. Exposure to absolute-maximum-rated conditions for extended periods may affect device reliability.
- (2) The input negative-voltage and output voltage ratings may be exceeded if the input and output current ratings are observed.

6.2 ESD Ratings

			VALUE	UNIT
V _(ESD)	Electrostatic discharge	Human body model (HBM), per ANSI/ESDA/JEDEC JS-001, all pins ⁽¹⁾	±2000	V
		Charged device model (CDM), per JEDEC specification JESD22-C101, all pins ⁽²⁾	±1000	

- (1) JEDEC document JEP155 states that 500-V HBM allows safe manufacturing with a standard ESD control process.
- (2) JEDEC document JEP157 states that 250-V CDM allows safe manufacturing with a standard ESD control process.

6.3 Recommended Operating Conditions

			MIN	MAX	UNIT
V _{CC}	Supply voltage		1.65	3.6	V
V _{IH}	High-level input voltage	SCL, SDA, ROW0–7, COL0–9, $\overline{\text{RESET}}$	0.7 × V _{CC}	3.6	V
V _{IL}	Low-level input voltage	SCL, SDA, ROW0–7, COL0–9, $\overline{\text{RESET}}$	-0.5	0.3 × V _{CC}	V
I _{OH}	High-level output current	ROW0–7, COL0–9		10	mA
I _{OL}	Low-level output current	ROW0–7, COL0–9		25	mA
T _A	Operating free-air temperature		-40	85	°C

6.4 Thermal Information

THERMAL METRIC ⁽¹⁾		TCA8418	UNIT
		RTW (WQFN)	
		24 PINS	
R _{θJA}	Junction-to-ambient thermal resistance	38.9	°C/W
R _{θJC(top)}	Junction-to-case (top) thermal resistance	40.6	°C/W
R _{θJB}	Junction-to-board thermal resistance	17.2	°C/W
ψ _{JT}	Junction-to-top characterization parameter	0.9	°C/W
ψ _{JB}	Junction-to-board characterization parameter	17.2	°C/W
R _{θJC(bot)}	Junction-to-case (bottom) thermal resistance	6.6	°C/W

- (1) For more information about traditional and new thermal metrics, see the [Semiconductor and IC Package Thermal Metrics](#) application report.

6.5 Electrical Characteristics

over recommended operating free-air temperature range, $V_{CC} = 1.65\text{ V to }3.6\text{ V}$ (unless otherwise noted)

PARAMETER		TEST CONDITIONS	V_{CC}	MIN	TYP	MAX	UNIT	
V_{IK}	Input diode clamp voltage	$I_I = -18\text{ mA}$	1.65 V to 3.6 V	-1.2			V	
V_{PORR}	Power-on reset voltage, V_{CC} rising	$V_I = V_{CC}$ or GND, $I_O = 0$	1.65 V to 3.6 V	1.03		1.43	V	
V_{PORF}	Power-on reset voltage, V_{CC} falling			0.76	1.15			
V_{OH}	ROW0–7, COL0–9 high-level output voltage	$I_{OH} = -1\text{ mA}$	1.65 V	1.25			V	
			1.65 V	1.2				
		$I_{OH} = -8\text{ mA}$	2.3 V	1.8				
			3 V	2.6				
		$I_{OH} = -10\text{ mA}$	1.65 V	1.1				
			2.3 V	1.7				
V_{OL}	ROW0–7, COL0–9 low-level output voltage	$I_{OL} = 1\text{ mA}$	1.65 V			0.4	V	
			1.65 V			0.45		
		$I_{OL} = 8\text{ mA}$	2.3 V			0.25		
			3 V			0.25		
		$I_{OL} = 10\text{ mA}$	1.65 V			0.6		
			2.3 V			0.3		
I_{OL}	SDA	$V_{OL} = 0.4\text{ V}$	1.65 V to 3.6 V	3			mA	
	\overline{INT} and $\overline{CAD_INT}$	$V_{OL} = 0.4\text{ V}$	1.65 V to 3.6 V	3				
I_I	SCL, SDA, ROW0–7, COL0–9, RESET	$V_I = V_{CCI}$ or GND	1.65 V to 3.6 V			1	μA	
R_{INT}	Internal pull-up resistor value	ROW0–7, COL0–9			105		k Ω	
I_{CC}	Supply current	V_I on SDA, ROW0–7, COL0–9 = V_{CC} or GND, $I_O = 0$, I/O = inputs,	$f_{SCL} = 0\text{ kHz}$	Oscillator OFF	1.65 V to 3.6 V		10	μA
				Oscillator ON			18	
			$f_{SCL} = 400\text{ kHz}$	1 key press	1.65 V		50	
					3.6 V		90	
			$f_{SCL} = 1\text{ MHz}$	1 key press	1.65 V		65	
					3.6 V		153	
			$f_{SCL} = 400\text{ kHz}$	GPI low (pull-up enable) ⁽¹⁾	1.65 V to 3.6 V		55	
						$f_{SCL} = 1\text{ MHz}$		
			$f_{SCL} = 400\text{ kHz}$	GPI low (pull-up disable)			15	
						$f_{SCL} = 1\text{ MHz}$		
$f_{SCL} = 400\text{ kHz}$	1 GPO active		55					
		$f_{SCL} = 1\text{ MHz}$		65				
C_I	SCL	$V_I = V_{CCI}$ or GND	1.65 V to 3.6 V		6	8	pF	
C_{IO}	SDA	$V_{IO} = V_{CC}$ or GND	1.65 V to 3.6 V		10	12.5	pF	
	ROW0–7, COL0–9				5	6		

(1) Assumes that one GPIO is enabled.

6.6 I²C Interface Timing Requirements

 over recommended operating free-air temperature range (unless otherwise noted) (see [Figure 16](#))

	STANDARD MODE I ² C BUS		FAST MODE I ² C BUS		FAST MODE PLUS (FM+) I ² C BUS		UNIT
	MIN	MAX	MIN	MAX	MIN	MAX	
f_{scl} I ² C clock frequency	0	100	0	400	0	1000	kHz
t_{sch} I ² C clock high time	4		0.6		0.26		μs
t_{scl} I ² C clock low time	4.7		1.3		0.5		μs
t_{sp} I ² C spike time		50		50		50	ns
t_{sds} I ² C serial data setup time	250		100		50		ns
t_{sdh} I ² C serial data hold time	0		0		0		ns
t_{icr} I ² C input rise time		1000	$20 + 0.1C_b^{(1)}$	300		120	ns
t_{icf} I ² C input fall time		300	$20 + 0.1C_b^{(1)}$	300		120	ns
t_{ocf} I ² C output fall time; 10 pF to 400 pF bus		300	$20 + 0.1C_b^{(1)}$	300		120	μs
t_{buf} I ² C bus free time between Stop and Start	4.7		1.3		0.5		μs
t_{sts} I ² C Start or repeater Start condition setup time	4.7		0.6		0.26		μs
t_{sth} I ² C Start or repeater Start condition hold time	4		0.6		0.26		μs
t_{sps} I ² C Stop condition setup time	4		0.6		0.26		μs
$t_{vd(data)}$ Valid data time; SCL low to SDA output valid		1		0.9		0.45	μs
$t_{vd(ack)}$ Valid data time of ACK condition; ACK signal from SCL low to SDA (out) low		1		0.9		0.45	μs

 (1) C_b = total capacitance of one bus line in pF

6.7 Reset Timing Requirements

 over recommended operating free-air temperature range (unless otherwise noted) (see [Figure 19](#))

	STANDARD MODE, FAST MODE, FAST MODE PLUS (FM+) I ² C BUS		UNIT
	MIN	MAX	
t_W Reset pulse duration	120 ⁽¹⁾		μs
t_{REC} Reset recovery time	120 ⁽¹⁾		μs
t_{RESET} Time to reset	120 ⁽¹⁾		μs

(1) The GPIO debounce circuit uses each GPIO input which passes through a two-stage register circuit. Both registers are clocked by the same clock signal, presumably free-running, with a nominal period of 50 μs. When an input changes state, the new state is clocked into the first stage on one clock transition. On the next same-direction transition, if the input state is still the same as the previously clocked state, the signal is clocked into the second stage, and then on to the remaining circuits. Since the inputs are asynchronous to the clock, it will take anywhere from zero to 50 μs after the input transition to clock the signal into the first stage. Therefore, the total debounce time may be as long as 100 μs. Finally, to account for a slow clock, the spec further guard-banded at 120 μs.

6.8 Switching Characteristics

PARAMETER		FROM	TO	STANDARD MODE, FAST MODE, FAST MODE PLUS (FM+) I ² C BUS		UNIT	
				MIN	MAX		
t _{IV}	Interrupt valid time	ROW0–7, COL0–9	$\overline{\text{INT}}$	20	60	μs	
				GPI_INT with Debounce_DIS_Low	40		120
				GPI_INT with Debounce_DIS_High	10		30
t _{IR}	Interrupt reset delay time	SCL	$\overline{\text{INT}}$		200	ns	
t _{PV}	Output data valid	SCL	ROW0–7, COL0–9		400	ns	
t _{PS}	Input data setup time	P port	SCL	0		ns	
t _{PH}	Input data hold time	P port	SCL	300		ns	

6.9 Keypad Switching Characteristics

PARAMETER	STANDARD MODE, FAST MODE, FAST MODE PLUS (FM+) I ² C BUS		UNIT
	MIN	MAX	
Key press to detection delay		25	μs
Key release to detection delay		25	μs
Keypad unlock timer		7	s
Keypad interrupt mask timer		31	s
Debounce		60	ms

6.10 Typical Characteristics

$T_A = 25^\circ\text{C}$ (unless otherwise noted)

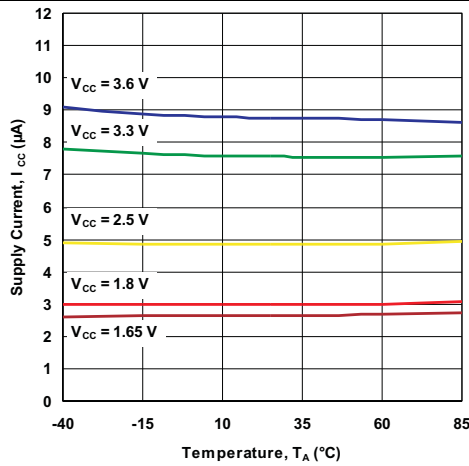

Figure 1. Supply Current vs Temperature

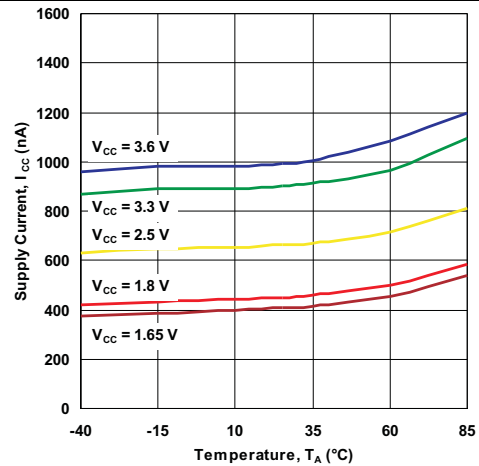

Figure 2. Standby Supply Current vs Temperature

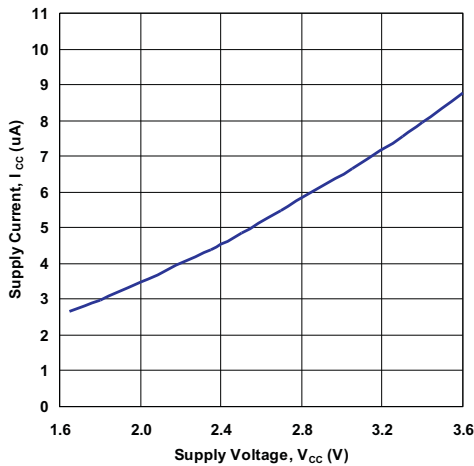

Figure 3. Supply Current vs Supply Voltage

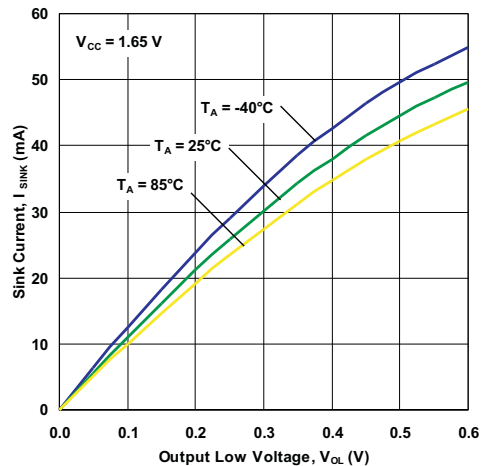

Figure 4. I/O Sink Current vs Output Low Voltage ($V_{CC} = 1.65\text{ V}$)

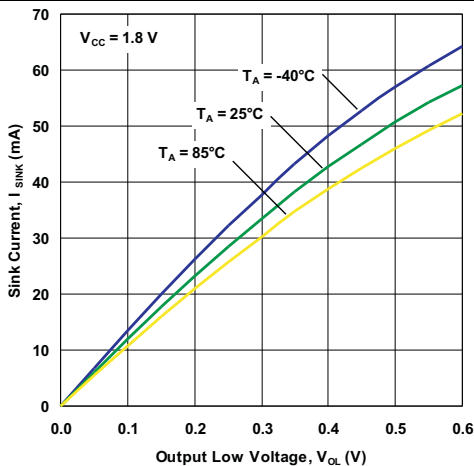

Figure 5. I/O Sink Current vs Output Low Voltage ($V_{CC} = 1.8\text{ V}$)

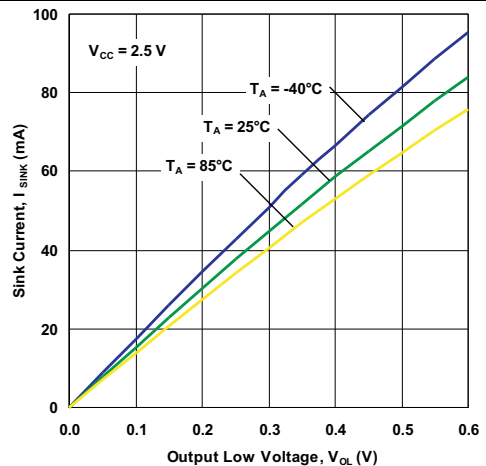

Figure 6. I/O Sink Current vs Output Low Voltage ($V_{CC} = 2.5\text{ V}$)

Typical Characteristics (continued)

$T_A = 25^\circ\text{C}$ (unless otherwise noted)

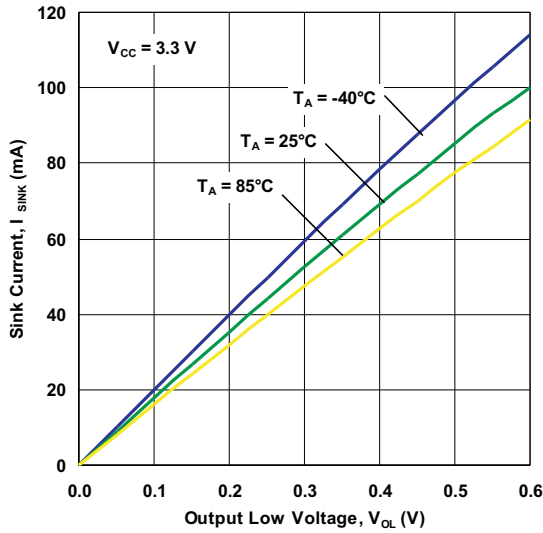

Figure 7. I/O Sink Current vs Output Low Voltage ($V_{CC} = 3.3\text{ V}$)

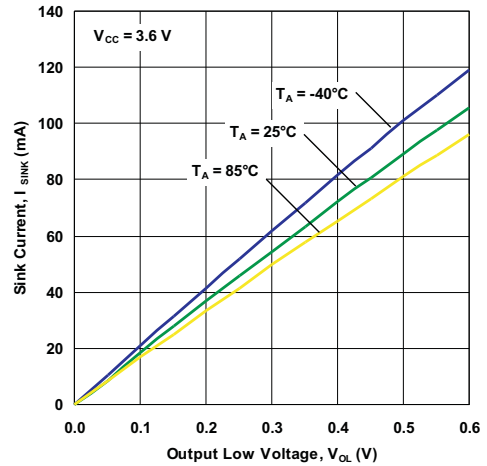

Figure 8. I/O Sink Current vs Output Low Voltage ($V_{CC} = 3.6\text{ V}$)

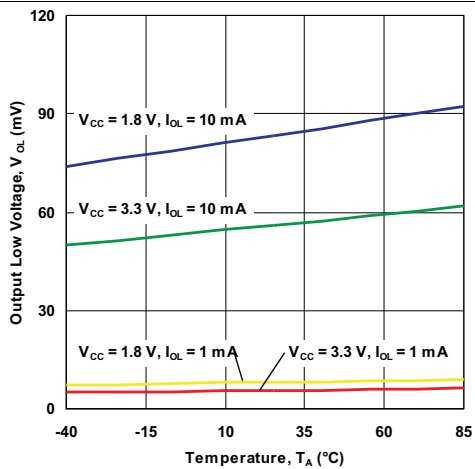

Figure 9. I/O Low Voltage vs Temperature

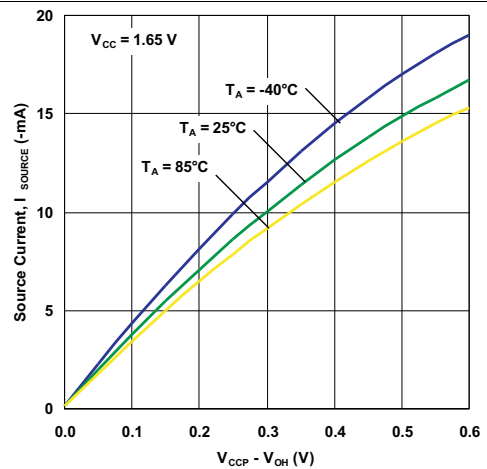

Figure 10. I/O Source Current vs Output High Voltage ($V_{CC} = 1.65\text{ V}$)

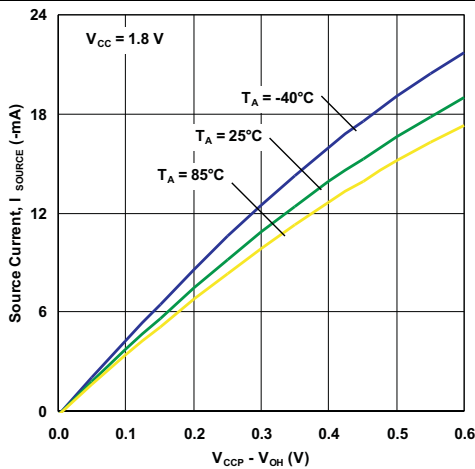

Figure 11. I/O Source Current vs Output High Voltage ($V_{CC} = 1.8\text{ V}$)

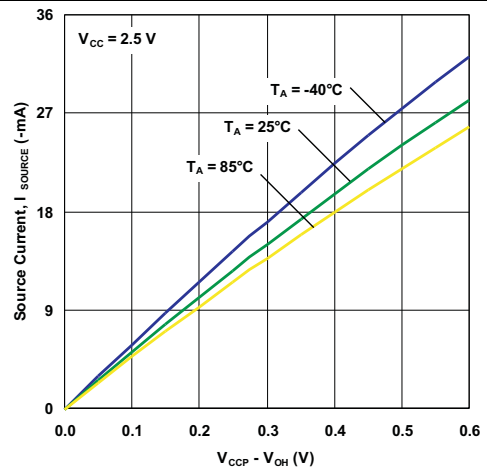

Figure 12. I/O Source Current vs Output High Voltage ($V_{CC} = 2.5\text{ V}$)

Typical Characteristics (continued)

$T_A = 25^\circ\text{C}$ (unless otherwise noted)

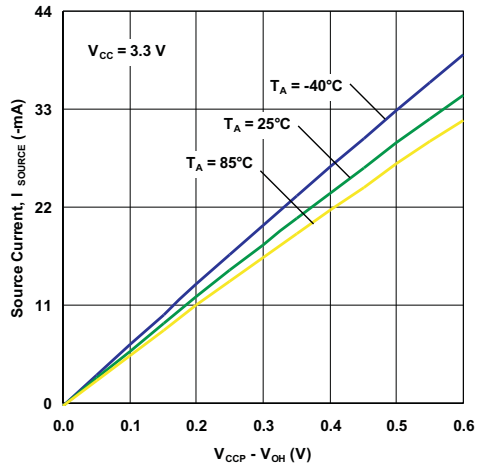

Figure 13. I/O Source Current vs Output High Voltage ($V_{CC} = 3.3\text{ V}$)

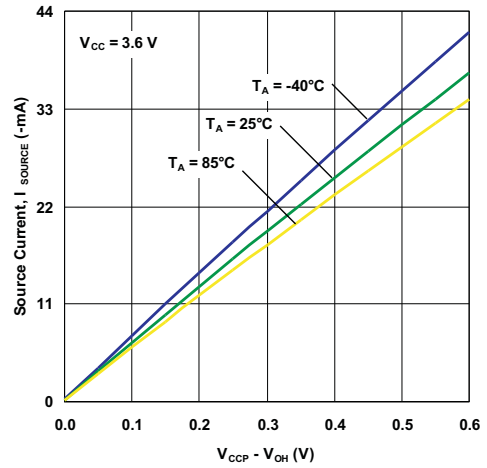

Figure 14. I/O Source Current vs Output High Voltage ($V_{CC} = 3.6\text{ V}$)

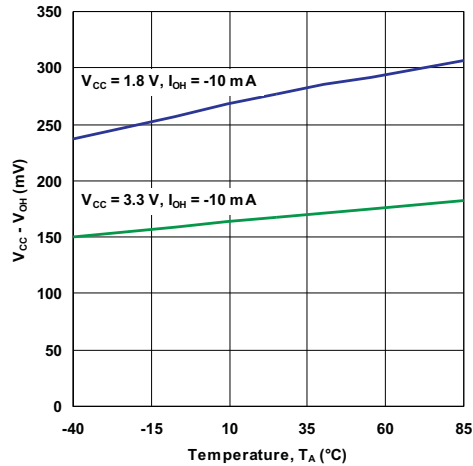
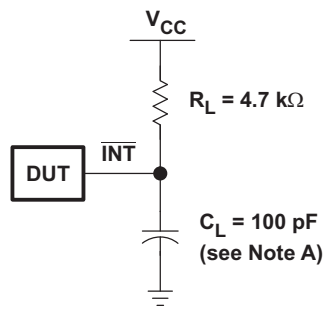
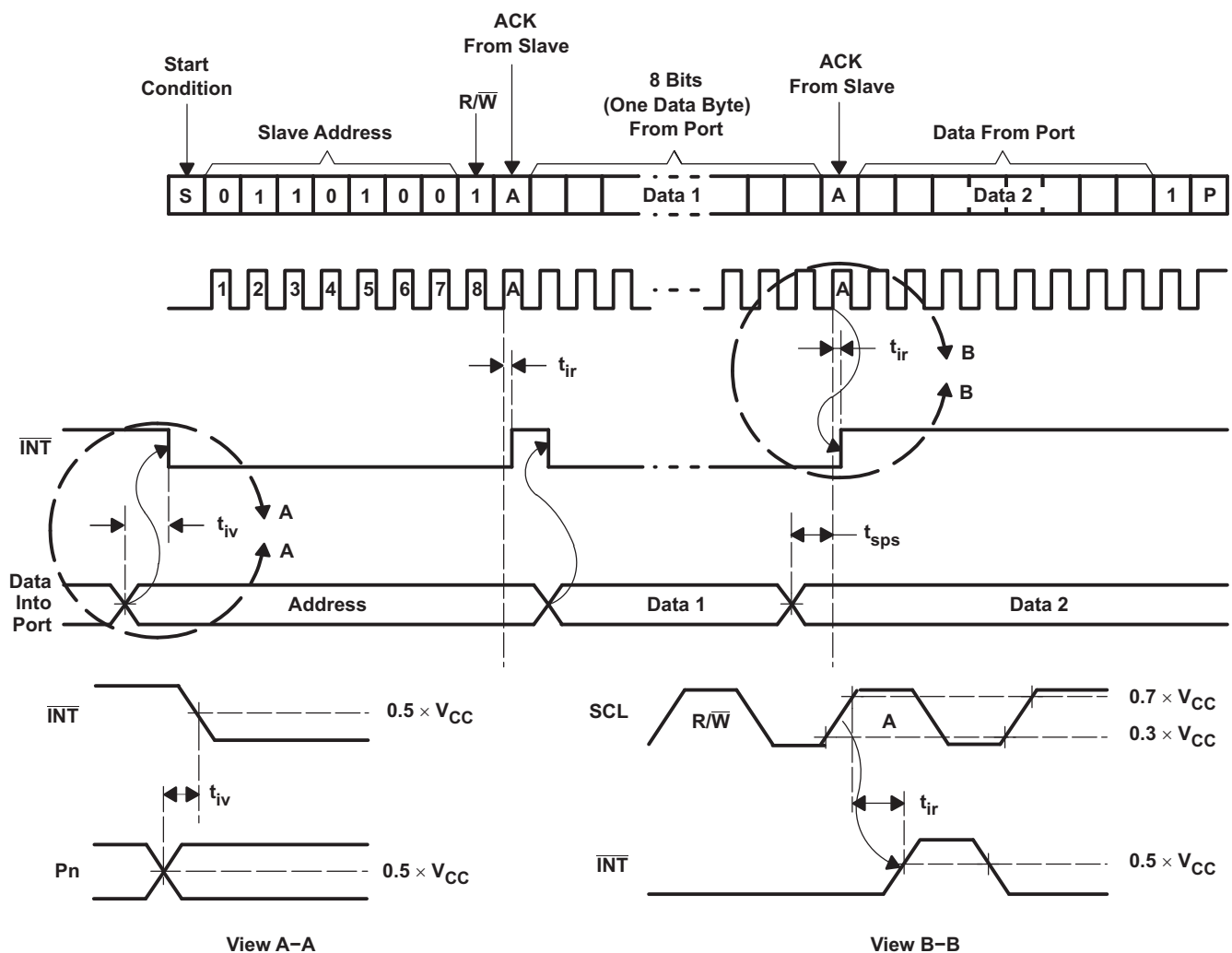

Figure 15. I/O High Voltage vs Temperature

Parameter Measurement Information (continued)



INTERRUPT LOAD CONFIGURATION



- A. C_L includes probe and jig capacitance.
- B. All inputs are supplied by generators having the following characteristics: $PRR \leq 10$ MHz, $Z_O = 50 \Omega$, $t_r/t_f \leq 30$ ns.
- C. All parameters and waveforms are not applicable to all devices.

Figure 17. Interrupt Load Circuit And Voltage Waveforms

Parameter Measurement Information (continued)

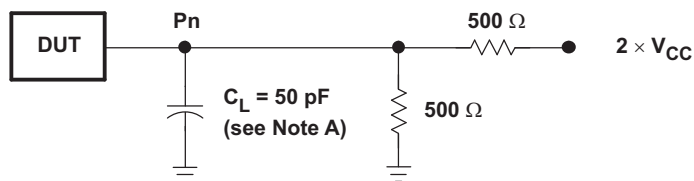

P-PORT LOAD CONFIGURATION

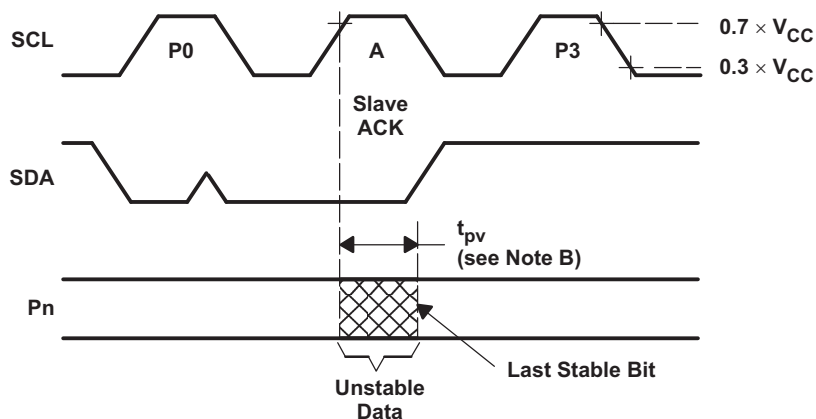

WRITE MODE ($R/\bar{W} = 0$)

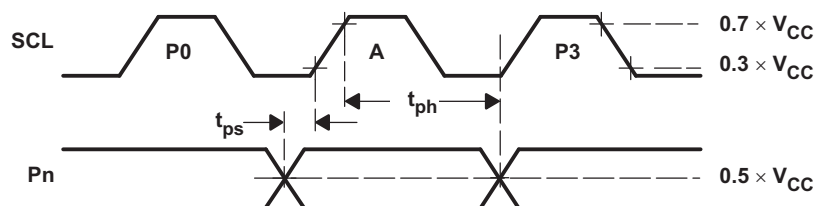

READ MODE ($R/\bar{W} = 1$)

- A. C_L includes probe and jig capacitance.
- B. t_{pv} is measured from $0.7 \times V_{CC}$ on SCL to 50% I/O (P_n) output.
- C. All inputs are supplied by generators having the following characteristics: $PRR \leq 10$ MHz, $Z_O = 50 \Omega$, $t_r/t_f \leq 30$ ns.
- D. The outputs are measured one at a time, with one transition per measurement.
- E. All parameters and waveforms are not applicable to all devices.

Figure 18. P Port Load Circuit And Timing Waveforms

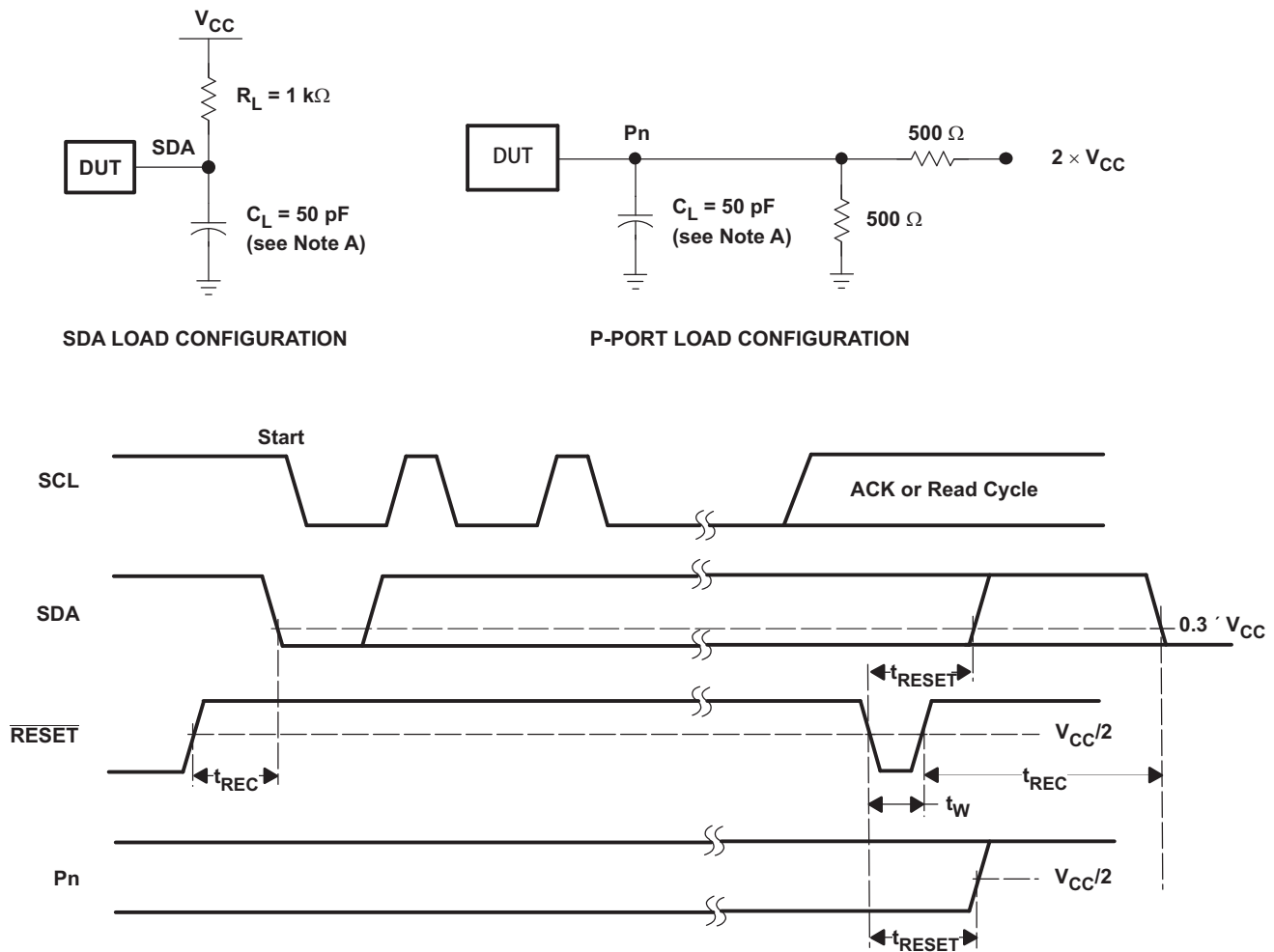
Parameter Measurement Information (continued)

- C_L includes probe and jig capacitance.
- All inputs are supplied by generators having the following characteristics: $PRR \leq 10$ MHz, $Z_O = 50 \Omega$, $t_r/t_f \leq 30$ ns.
- The outputs are measured one at a time, with one transition per measurement.
- I/Os are configured as inputs.
- All parameters and waveforms are not applicable to all devices.

Figure 19. Reset Load Circuits And Voltage Waveforms

8 Detailed Description

8.1 Overview

The TCA8418 supports up to 10 columns Table 9 by 8 rows of keys, up to 80 keys. Any combination of these rows and columns can be configured to be added to the keypad matrix. This is done by setting the appropriate rows and columns to a value of 1 in the corresponding KP_GPIO registers (seen in). Once the rows and columns that are connected to the keypad matrix are added to the keypad array, then the TCA8418 will begin monitoring the keypad array, and any configured general purpose inputs (GPIs).

8.2 Functional Block Diagram

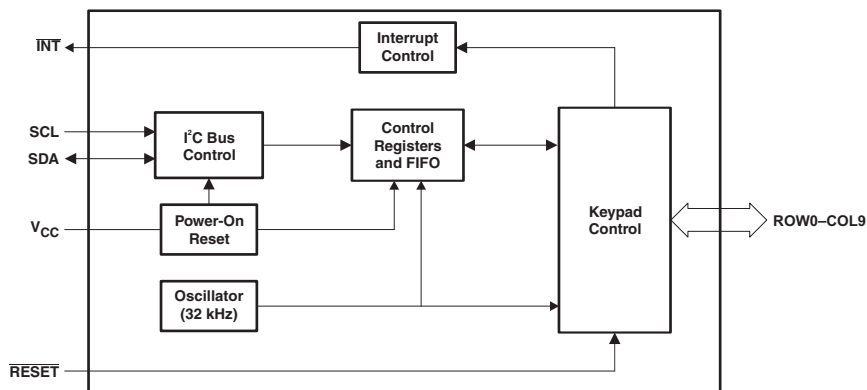

8.3 Feature Description

8.3.1 Key Events

8.3.1.1 Key Event Table

The TCA8418 can be configured to support many different configurations of keypad setups. All 18 GPIOs for the rows and columns can be used to support up to 80 keys in a key pad array. Another option is that all 18 GPIOs be used for GPIs to read 18 buttons which are not connected in an array. Any combination in between is also acceptable (for example, a 3 x 4 keypad matrix and using the remaining 11 GPIOs as a combination of inputs and outputs).

For both types of inputs (keypad matrix and a GPI), a key event can be added to the key event FIFO. The values that are added to the FIFO depend on the configuration (keypad array or GPI) and on which port the press was read on. The tables below show the values that correspond to both types of configurations.

Key values below are represented in decimal values, because the 10s place is used to mark the row, and the ones place is used to denote the column. It is more clear to see the numbering convention used when viewed in decimal values.

Table 1. Key Event Table (Keypad Array)

	C0	C1	C2	C3	C4	C5	C6	C7	C8	C9
R0	1	2	3	4	5	6	7	8	9	10
R1	11	12	13	14	15	16	17	18	19	20
R2	21	22	23	24	25	26	27	28	29	30
R3	31	32	33	34	35	36	37	38	39	40
R4	41	42	43	44	45	46	47	48	49	50
R5	51	52	53	54	55	56	57	58	59	60
R6	61	62	63	64	65	66	67	68	69	70
R7	71	72	73	74	75	76	77	78	79	80

Table 2. Key Event Table (Row GPI Events)

R0	R1	R2	R3	R4	R5	R6	R7
97	98	99	100	101	102	103	104

Table 3. Key Event Table (Column GPI Events)

C0	C1	C2	C3	C4	C5	C6	C7	C8	C9
105	106	107	108	109	110	111	112	113	114

8.3.1.2 General Purpose Input (GPI) Events

A column or row configured as GPI can be programmed to be part of the [Key Event Table](#), hence becomes also capable of generating Key Event Interrupt. A Key Event Interrupt caused by a GPI follow the same process flow as a Key Event Interrupt caused by a Key press.

GPIs configured as part of the Key Event Table allows for single key switches to be monitored as well as other GPI interrupts. As part of the Event Table, GPIs are represented with decimal value of 97 and run through decimal value of 114. R0-R7 are represented by 97-104 and C0-C9 are represented by 105-114

For a GPI that is set as active high, and is enabled in the Key Event Table, the state-machine will add an event to the event count and event table whenever that GPI goes high. If the GPI is set to active low, a transition from high to low will be considered a press and will also be added to the event count and event table. Once the interrupt state has been met, the state machine will internally set an interrupt for the opposite state programmed in the register to avoid polling for the released state, hence saving current. Once the released state is achieved, it will add it to the event table. The press and release will still be indicated by bit 7 in the event register.

The GPI Events can also be used as unlocked sequences. When the GPI_EM bit is set, GPI events will not be tracked when the keypad is locked. GPI_EM bit must be cleared for the GPI events to be tracked in the event counter and table when the keypad is locked.

8.3.1.3 Key Event (FIFO) Reading

The TCA8418 has a 10-byte event FIFO, which stores any key presses or releases which have been configured to be added to the Key Event Table. All ROWs and COLs added to the keypad matrix via the [KP_GPIO1-3 Registers](#) will have any key pad events added to the FIFO. Any GPIs configured with a 1 in the [GPI_EM1-3 Registers](#) will also be part of the event FIFO.

When the host wishes to read the FIFO, the following procedure is recommended.

1. Read the [INT_STAT \(0x02\)](#) register to determine what asserted the $\overline{\text{INT}}$ line. If GPI_INT or K_INT is set, then a key event has occurred, and the event is stored in the FIFO.
2. Read the [KEY_LCK_EC \(0x03\)](#) register, bits [3:0] to see how many events are stored in FIFO.
3. Read the [KEY_EVENT_A \(0x04\)](#) register. Bit 7 value '0' signifies key release, value 1 signifies key press. Bits [6:0] state which key was pressed with respect to the [Key Event Table](#). With each read of the key event register, the event counter in KEY_LCK_EC[3:0] will decrease by 1, and the FIFO will shift the events down 1 register.
4. Repeat step 3 until either KEY_LCK_EC[3:0] = 0 or KEY_EVENT_A = 0. This signifies that the FIFO is empty.
5. Reset the [INT_STAT](#) interrupt flag which was causing the interrupt by writing a 1 to the specific bit.

As an example, consider the following key presses.

Table 4. Example Key Sequence

Event #	Key (Decimal Value)	Press/Release
1	1	Press
2	32	Press
3	1	Release
4	32	Release
5	23	Press
6	23	Release
7	45	Press
8	41	Press
9	41	Release
10	45	Release

If this example key sequence occurs, then while performing the recommended read procedure listed above, the host would see the following information. Information at the top of the list is of an initial read to the KEY_LCK_EC[3:0] register.

Table 5. Example Key Sequence

KEY_LCK_EC[3:0] Value	KEY_EVENT_A Value (Binary/Hex)	Key (Decimal Value)	Press/Release
10	N/A	N/A	N/A
9	1 000 0001 (0x81)	1	Press
8	1 010 0000 (0xA0)	32	Press
7	0 000 0001 (0x01)	1	Release
6	0 010 0000 (0x20)	32	Release
5	1 001 0111 (0x97)	23	Press
4	0 001 0111 (0x17)	23	Release
3	1 010 1101 (0xAD)	45	Press
2	1 010 1001 (0xA9)	41	Press
1	0 010 1001 (0x29)	41	Release
0	0 010 1101 (0x2D)	45	Release

⁽¹⁾8.3.1.4 Key Event Overflow

The TCA8418 has the ability to handle an overflow of the key event FIFO. An overflow event occurs when the FIFO is full of events (10 key events are stored) and a new key event occurs. In short, this means that the TCA8418 does not have the ability to hold any more key press information in the internal buffer. When this occurs, the OVR_FLOW_INT bit in the *INT_STAT Register* is set, and if the OVR_FLOW_IEN bit is set in the *CFG Register*, then the $\overline{\text{INT}}$ output will be asserted low to let the processor know that an overflow has occurred.

The TCA8418 has the ability to handle an overflow in 1 of two ways, which is determined by the bit value of the OVR_FLOW_M bit in the *CFG Register*.

Please see the *Overflow Errata* section for more information about overflow behavior.

Table 6. OVR_FLOW_M Bit

OVR_FLOW_M Value	Overflow Mode	Behavior
1	Enabled	Overflow data shifts with last event pushing first event out
0	Disabled (Default)	Overflow data is not stored and lost

(1) Note that the MSB of the KEY_EVENT_A value signifies a key press or release. MSB Bit = 1 signifies a key press; MSB Bit = 0 signifies a key release

Consider the example below, if the FIFO is full of the key presses and a new key press comes in. This new overflow key press will be a key press of key 2 (0x82 is the hex representation of a key 2 press event)

Table 7. Key Event Overflow Handling

FIFO Register	Original Value	After Key 1 Press Event (0x82)	
		OVR_FLOW_M = 1	OVR_FLOW_M = 0
A	0x81	0xA0	0x81
B	0xA0	0x01	0xA0
C	0x01	0x20	0x01
D	0x20	0x97	0x20
E	0x97	0x17	0x97
F	0x17	0xAD	0x17
H	0xAD	0xA9	0xAD
I	0xA9	0x29	0xA9
J	0x29	0x2D	0x29
K	0x2D	0x82	0x2D

8.3.2 Keypad Lock/Unlock

This user can lock the keypad through the lock/unlock feature in this device. Once the keypad is locked by setting BIT6 in [KEY_LCK_EC](#), it can prevent the generation of key event interrupts and recorded key events. The unlock keys can be programmed with any value of the keys in the keypad matrix or any general purpose input (GPI) values that are part of the [Key Event Table](#). When the keypad lock interrupt mask timer is non-zero, the user will need to press two specific keys before an keylock interrupt is generated or keypad events are recorded. A key event interrupt is generated the first time a user presses any key. This first interrupt can be used to turn on an LCD and display the unlock message. The processor will then read the lock status register to see if the keypad is unlocked. The next interrupt (keylock interrupt) will not be generated unless both unlock keys sequences are correct. If correct Unlock keys are not pressed before the mask timer expires, the state machine will start over again.

The recommended procedure to lock the keypad is to do the following

1. Determine which keys will be used for the unlock sequence. The key value from the [Key Event Tables](#) needs to be entered into the [UNLOCK1](#) and [UNLOCK2](#) registers.
2. The UNLOCK1 to UNLOCK2 timer duration must be set by entering the desired seconds (valid range is 0 to 7 seconds) into bits [2:0] of the [KP_LCK_TMR](#) register.
3. If an interrupt mask is desired (see [Keypad Lock Interrupt Mask Timer](#)), then the desired interrupt mask duration (valid range is 0 to 31 seconds) must be entered into bits [7:3] of the [KP_LCK_TMR](#) register.
4. When the host is ready to lock the keypad, a 1 is to be written to the K_LCK_EN bit (BIT6) in the [KEY_LCK_EC](#) register. This will lock the keypad.
5. If the host wishes to manually unlock the keypad, writing a '0' to the K_LCK_EN bit (BIT6) in the [KEY_LCK_EC](#) register will unlock the keypad.

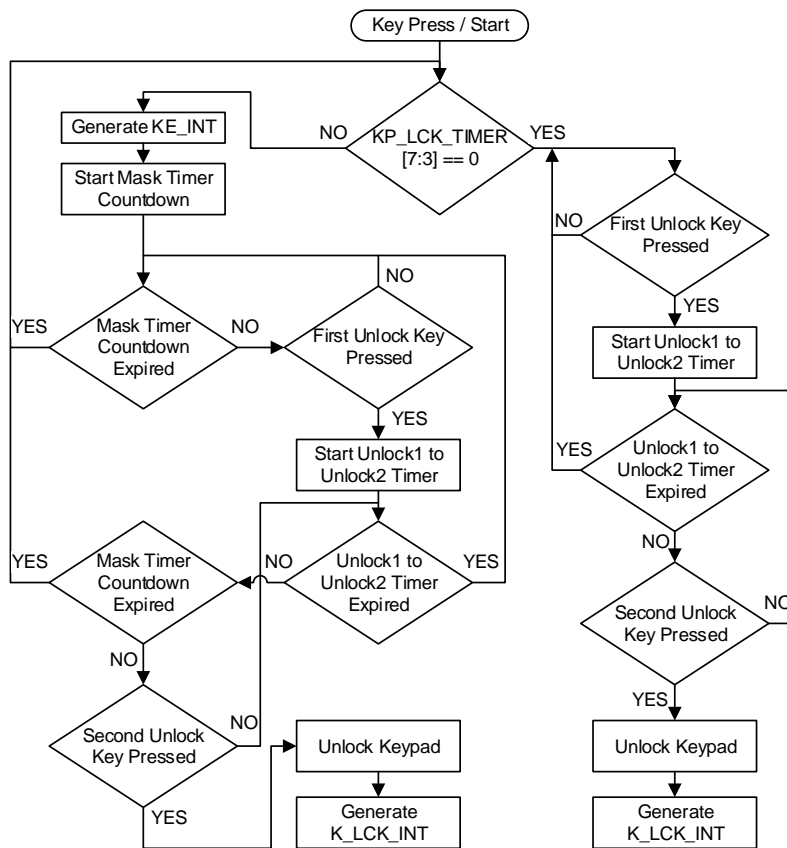

Figure 20. Keypad Lock Flowchart

8.3.3 Keypad Lock Interrupt Mask Timer

The TCA8418 features a *Keypad Lock/Unlock* feature which allows the user to stop the generation of key event interrupts by locking the keypad. There is an interrupt mask timer feature with the keypad lock, which allows the generation of a single interrupt when a key is pressed, primarily for the purpose of LCD backlighting. Note that this interrupt mask timer can also be used to limit the number of interrupts generated for a given amount of time.

The interrupt mask timer is enabled by setting bits [7:3] of the *KP_LCK_TIMER* register. The value in this register can be anywhere from 0 to 31 seconds (note that a value of 0 will disable this interrupt mask feature). When a keypad is locked and the interrupt mask timer is set to a non-zero value, this will enable the interrupt mask timer. This interrupt mask timer limits the amount of interrupts generated. Typically, this is used with the *Keypad Lock/Unlock* feature for LCD back lights. It is easiest to explain this feature with the following example; A mobile device has a LCD screen with a back light display which turns off after 10 seconds to save power. Normally, an interrupt to the processor would tell this LCD back light to turn on. When the keypad is locked, no interrupts are generated, so the back light will never turn on. This is where the interrupt mask feature is used. Please refer to [Figure 20](#). The procedure for an example is below.

1. Since the back light turns off after 10 seconds of no interrupts, the interrupt mask timer (*KP_LCK_TIMER*[7:3]) gets set to 10 seconds. Keypad is then locked.
2. When the first key press is detected, the TCA8418 sends an interrupt to the processor and starts a 10 second count down.
3. If the correct unlock sequence is not entered within the 10 seconds, no interrupts are sent and the back light will turn off.
4. After the 10 second timer has expired, if another key press occurs while keypad is locked (regardless of whether it is a correct unlock key or not), another interrupt is generated and the 10 second count down begins again.

8.3.4 Control-Alt-Delete Support

The TCA8418 can support normal key presses, but it also can support a <Ctrl><Alt> (CAD) key press. This feature allows the host to recognize a specific key press and alert the host that the combination has occurred. The TCA8418 will recognize a <Ctrl><Alt> key press if keys 1, 11, and 21 are all pressed at the same time. These keys are referenced to the key values listed in the [Key Event Table](#). Note that this key combination that triggers a CAD interrupt is not adjustable, and must be keys 1, 11, and 21.

Please see [CAD Interrupt Errata](#) for more information.

8.3.5 Interrupt Output

An interrupt is generated by any rising or falling edge of the port inputs in the input mode. After time t_{iv} , the signal \overline{INT} is valid. Resetting the interrupt circuit is achieved when data on the port is changed to the original setting or data is read from the port that generated the interrupt. Resetting occurs in the read mode at the acknowledge (ACK) or not acknowledge (NACK) bit after the rising edge of the SCL signal. Interrupts that occur during the ACK or NACK clock pulse can be lost (or be very short) due to the resetting of the interrupt during this pulse. Each change of the I/Os after resetting is detected and is transmitted as \overline{INT} .

Reading from or writing to another device does not affect the interrupt circuit, and a pin configured as an output cannot cause an interrupt. Changing an I/O from an output to an input may cause a false interrupt to occur, if the state of the pin does not match the contents of the input port register.

The \overline{INT} output has an open-drain structure and requires a pull-up resistor to V_{CC} depending on the application. If the \overline{INT} signal is connected back to the processor that provides the SCL signal to the TCA8418, then the \overline{INT} pin has to be connected to V_{CC} . If not, the \overline{INT} pin can be connected to V_{CC} .

8.3.5.1 50 Micro-second Interrupt Configuration

The TCA8418 provides the capability of deasserting the interrupt for 50 μ s while there is a pending event. When the INT_CFG bit in Register 0x01 is set, any attempt to clear the interrupt bit while the interrupt pin is already asserted results in a 50 μ s deassertion. When the INT_CFG bit is cleared, \overline{INT} remains asserted if the host tries to clear the interrupt. This feature is particularly useful for software development and edge triggering applications.

8.4 Device Functional Modes

8.4.1 Power-On Reset (POR)

When power (from 0 V) is applied to V_{CC} , an internal power-on reset circuit holds the TCA8418 in a reset condition until V_{CC} has reached V_{PORR} . At that time, the reset condition is released, and the TCA8418 registers and I²C/SMBus state machine initialize to their default states. After that, V_{CC} must be lowered to below V_{PORF} and back up to the operating voltage for a power-reset cycle. See [Power Supply Recommendations](#) for more information on power up reset requirements.

8.4.2 Powered (Key Scan Mode)

The TCA8418 can be used to read GPI from single buttons, or configured in key scan mode to read an array of keys. In key scan mode, there are two modes of operation.

8.4.2.1 Idle Key Scan Mode

Once the TCA8418 has had the keypad array configured, it will enter idle mode when no keys are being pressed. All columns configured as part of the keypad array will be driven low and all rows configured as part of the keypad array will be set to inputs, with pull-up resistors enabled. During idle mode, the internal oscillator is turned off so that power consumption is low as the device awaits a key press.

8.4.2.2 Active Key Scan Mode

When the TCA8418 is in idle key scan mode, the device awaits a key press. Once a key is pressed in the array, a low signal on one of the ROW pin inputs triggers an interrupt, which will turn on the internal oscillator and enter the active key scan mode. At this point, the TCA8418 will start the key scan algorithm to determine which key is being pressed, and/or it will use the internal oscillator for debouncing. Once all keys have been released, the device will enter idle key scan mode.

8.5 Programming

8.5.1 I²C Interface

The TCA8418 has a standard bidirectional I²C interface that is controlled by a master device in order to be configured or read the status of this device. Each slave on the I²C bus has a specific device address to differentiate between other slave devices that are on the same I²C bus. Many slave devices will require configuration upon startup to set the behavior of the device. This is typically done when the master accesses internal register maps of the slave, which have unique register addresses. A device can have one or multiple registers where data is stored, written, or read.

The physical I²C interface consists of the serial clock (SCL) and serial data (SDA) lines. Both SDA and SCL lines must be connected to V_{CC} through a pull-up resistor. The size of the pull-up resistor is determined by the amount of capacitance on the I²C lines. (For further details, refer to *I²C pull-up Resistor Calculation (SLVA689)*.) Data transfer may be initiated only when the bus is idle. A bus is considered idle if both SDA and SCL lines are high after a STOP condition.

The following is the general procedure for a master to access a slave device:

1. If a master wants to send data to a slave:
 - Master-transmitter sends a START condition and addresses the slave-receiver.
 - Master-transmitter sends data to slave-receiver.
 - Master-transmitter terminates the transfer with a STOP condition.
2. If a master wants to receive or read data from a slave:
 - Master-receiver sends a START condition and addresses the slave-transmitter.
 - Master-receiver sends the requested register to read to slave-transmitter.
 - Master-receiver receives data from the slave-transmitter.
 - Master-receiver terminates the transfer with a STOP condition.

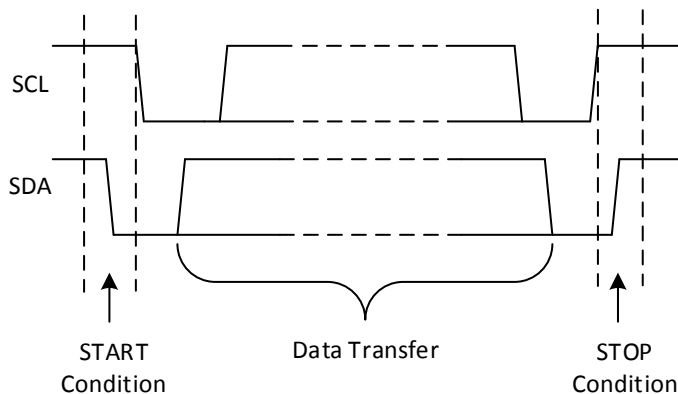
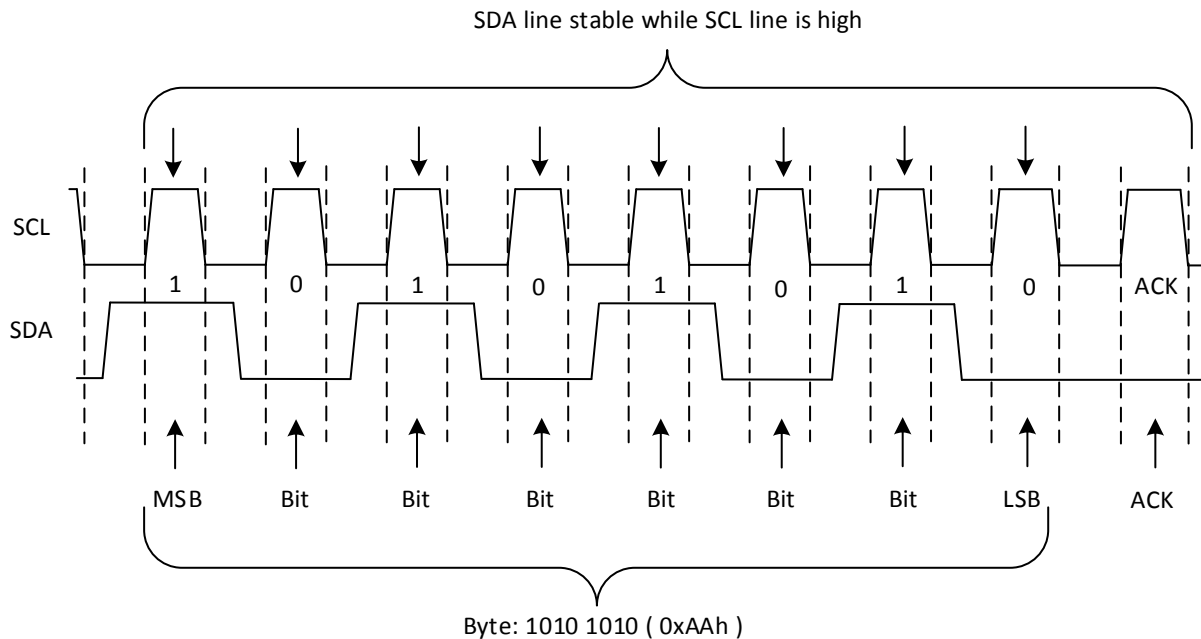

Figure 21. Definition of Start and Stop Conditions

Programming (continued)

Figure 22. Bit Transfer
8.5.2 Bus Transactions

Data must be sent to and received from the slave devices, and this is accomplished by reading from or writing to registers in the slave device.

Registers are locations in the memory of the slave which contain information, whether it be the configuration information or some sampled data to send back to the master. The master must write information to these registers in order to instruct the slave device to perform a task.

While it is common to have registers in I²C slaves, note that not all slave devices will have registers. Some devices are simple and contain only 1 register, which may be written to directly by sending the register data immediately after the slave address, instead of addressing a register. An example of a single-register device would be an 8-bit I²C switch, which is controlled via I²C commands. Since it has 1 bit to enable or disable a channel, there is only 1 register needed, and the master merely writes the register data after the slave address, skipping the register number.

8.5.2.1 Writes

To write on the I²C bus, the master will send a START condition on the bus with the address of the slave, as well as the last bit (the R/W bit) set to 0, which signifies a write. After the slave sends the acknowledge bit, the master will then send the register address of the register to which it wishes to write. The slave will acknowledge again, letting the master know it is ready. After this, the master will start sending the register data to the slave until the master has sent all the data necessary (which is sometimes only a single byte), and the master will terminate the transmission with a STOP condition.

Figure 23 shows an example of writing a single byte to a register.

Programming (continued)

- Master controls SDA line
- Slave controls SDA line

Write to one register in a device

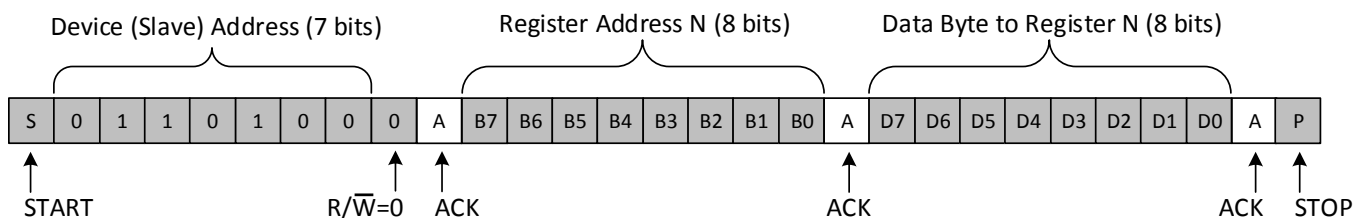

Figure 23. Write to Register

- Master controls SDA line
- Slave controls SDA line

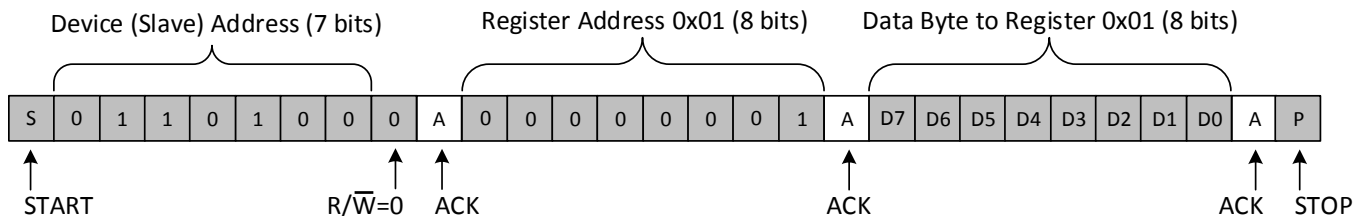

Figure 24. Write to Configuration Register

8.6 Register Maps

8.6.1 Device Address

The address of the TCA8418 is shown in [Table 8](#).

Table 8. TCA8418 Device Addresses

BYTE	BIT							
	7 (MSB)	6	5	4	3	2	1	0 (LSB)
I ² C slave address	0	1	1	0	1	0	0	R/W

The last bit of the slave address defines the operation (read or write) to be performed. A high (1) selects a read operation, while a low (0) selects a write operation.

8.6.2 Control Register and Command Byte

Following the successful acknowledgment of the address byte, the bus master sends a command byte, which is stored in the control register in the TCA8418. The command byte indicates the register that will be updated with information. All registers can be read and written to by the system master.

[Table 9](#) shows all the registers within this device and their descriptions. The default value in all registers is 0.

Table 9. Register Descriptions

ADDRESS	REGISTER NAME	REGISTER DESCRIPTION	7	6	5	4	3	2	1	0
0x00	Reserved	Reserved								
0x01	CFG	Configuration register (interrupt processor interrupt enables)	AI	GPI_E_CGF	OVR_FL_OW_M	INT_CFG	OVR_FLOW_IEN	K_LC_K_IEN	GPI_IEN	KE_IEN
0x02	INT_STAT	Interrupt status register	N/A 0	N/A 0	N/A 0	CAD_I NT	OVR_FLOW_I NT	K_LC_K_I NT	GPI_I NT	K_I NT
0x03	KEY_LCK_EC	Key lock and event counter register	N/A 0	K_LCK_EN	LCK2	LCK1	KLEC3	KLEC2	KLEC1	KLEC0
0x04	KEY_EVENT_A	Key event register A	KEA7 0	KEA6 0	KEA5 0	KEA4 0	KEA3 0	KEA2 0	KEA1 0	KEA0 0
0x05	KEY_EVENT_B	Key event register B	KEB7 0	KEB6 0	KEB5 0	KEB4 0	KEB3 0	KEB2 0	KEB1 0	KEB0 0
0x06	KEY_EVENT_C	Key event register C	KEC7 0	KEC6 0	KEC5 0	KEC4 0	KEC3 0	KEC2 0	KEC1 0	KEC0 0
0x07	KEY_EVENT_D	Key event register D	KED7 0	KED6 0	KED5 0	KED4 0	KED3 0	KED2 0	KED1 0	KED0 0
0x08	KEY_EVENT_E	Key event register E	KEE7 0	KEE6 0	KEE5 0	KEE4 0	KEE3 0	KEE2 0	KEE1 0	KEE0 0
0x09	KEY_EVENT_F	Key event register F	KEF7 0	KEF6 0	KEF5 0	KEF4 0	KEF3 0	KEF2 0	KEF1 0	KEF0 0
0x0A	KEY_EVENT_G	Key event register G	KEG7 0	KEG6 0	KEG5 0	KEG4 0	KEG3 0	KEG2 0	KEG1 0	KEG0 0
0x0B	KEY_EVENT_H	Key event register H	KEH7 0	KEH6 0	KEH5 0	KEH4 0	KEH3 0	KEH2 0	KEH1 0	KEH0 0
0x0C	KEY_EVENT_I	Key event register I	KEI7 0	KEI6 0	KEI5 0	KEI4 0	KEI3 0	KEI2 0	KEI1 0	KEI0 0
0x0D	KEY_EVENT_J	Key event register J	KEJ7 0	KEJ6 0	KEJ5 0	KEJ4 0	KEJ3 0	KEJ2 0	KEJ1 0	KEJ0 0
0x0E	KP_LCK_TIMER	Keypad lock 1 to lock 2 timer	KL7	KL6	KL5	KL4	KL3	KL2	KL1	KL0
0x0F	UNLOCK1	Unlock key 1	UK1_7	UK1_6	UK1_5	UK1_4	UK1_3	UK1_2	UK1_1	UK1_0
0x10	UNLOCK1	Unlock key2	UK2_7	UK2_6	UK2_5	UK2_4	UK2_3	UK2_2	UK2_1	UK2_0

Table 9. Register Descriptions (continued)

ADDRESS	REGISTER NAME	REGISTER DESCRIPTION	7	6	5	4	3	2	1	0
0x11	GPIO_INT_STAT1	GPIO interrupt status	R7IS 0	R6IS 0	R5IS 0	R4IS 0	R3IS 0	R2IS 0	R1IS 0	R0IS 0
0x12	GPIO_INT_STAT2	GPIO interrupt status	C7IS 0	C6IS 0	C5IS 0	C4IS 0	C3IS 0	C2IS 0	C1IS 0	C0IS 0
0x13	GPIO_INT_STAT3	GPIO interrupt status	N/A 0	N/A 0	N/A 0	N/A 0	N/A 0	N/A 0	C9IS 0	C8IS 0
0x14	GPIO_DAT_STAT1 (read twice to clear)	GPIO data status	R7DS	R6DS	R5DS	R4DS	R3DS	R2DS	R1DS	R0DS
0x15	GPIO_DAT_STAT2 (read twice to clear)	GPIO data status	C7DS	C6DS	C5DS	C4DS	C3DS	C2DS	C1DS	C0DS
0x16	GPIO_DAT_STAT3 (read twice to clear)	GPIO data status	N/A 0	N/A 0	N/A 0	N/A 0	N/A 0	N/A 0	C9DS	C8DS
0x17	GPIO_DAT_OUT1	GPIO data out	R7DO 0	R6DO 0	R5DO 0	R4DO 0	R3DO 0	R2DO 0	R1DO 0	R0DO 0
0x18	GPIO_DAT_OUT2	GPIO data out	C7DO 0	C6DO 0	C5DO 0	C4DO 0	C3DO 0	C2DO 0	C1DO 0	C0DO 0
0x19	GPIO_DAT_OUT3	GPIO data out	N/A 0	N/A 0	N/A 0	N/A 0	N/A 0	N/A 0	C9DO 0	C8DO 0
0x1A	GPIO_INT_EN1	GPIO interrupt enable	R7IE 0	R6IE 0	R5IE 0	R4IE 0	R3IE 0	R2IE 0	R1IE 0	R0IE 0
0x1B	GPIO_INT_EN2	GPIO interrupt enable	C7IE 0	C6IE 0	C5IE 0	C4IE 0	C3IE 0	C2IE 0	C1IE 0	C0IE 0
0x1C	GPIO_INT_EN3	GPIO interrupt enable	N/A 0	N/A 0	N/A 0	N/A 0	N/A 0	N/A 0	C9IE 0	C8IE 0
0x1D	KP_GPIO1	Keypad or GPIO selection 0: GPIO 1: KP matrix	ROW7 0	ROW6 0	ROW5 0	ROW4 0	ROW3 0	ROW2 0	ROW1 0	ROW0 0
0x1E	KP_GPIO2	Keypad or GPIO selection 0: GPIO 1: KP matrix	COL7 0	COL6 0	COL5 0	COL4 0	COL3 0	COL2 0	COL1 0	COL0 0
0x1F	KP_GPIO3	Keypad or GPIO selection 0: GPIO 1: KP matrix	N/A 0	N/A 0	N/A 0	N/A 0	N/A 0	N/A 0	COL9 0	COL8 0
0x20	GPI_EM1	GPI event mode 1	ROW7 0	ROW6 0	ROW5 0	ROW4 0	ROW3 0	ROW2 0	ROW1 0	ROW0 0
0x21	GPI_EM2	GPI event mode 2	COL7 0	COL6 0	COL5 0	COL4 0	COL3 0	COL2 0	COL1 0	COL0 0
0x22	GPI_EM3	GPI event mode 3	N/A 0	N/A 0	N/A 0	N/A 0	N/A 0	N/A 0	COL9 0	COL8 0
0x23	GPIO_DIR1	GPIO data direction 0: input 1: output	R7DD 0	R6DD 0	R5DD 0	R4DD 0	R3DD 0	R2DD 0	R1DD 0	R0DD 0
0x24	GPIO_DIR2	GPIO data direction 0: input 1: output	C7DD 0	C6DD 0	C5DD 0	C4DD 0	C3DD 0	C2DD 0	C1DD 0	C0DD 0
0x25	GPIO_DIR3	GPIO data direction 0: input 1: output	N/A 0	N/A 0	N/A 0	N/A 0	N/A 0	N/A 0	C9DD 0	C8DD 0

Table 9. Register Descriptions (continued)

ADDRESS	REGISTER NAME	REGISTER DESCRIPTION	7	6	5	4	3	2	1	0
0x26	GPIO_INT_LVL1	GPIO edge/level detect 0: falling/low 1: rising/high	R7IL 0	R6IL 0	R5IL 0	R4IL 0	R3IL 0	R2IL 0	R1IL 0	R0IL 0
0x27	GPIO_INT_LVL2	GPIO edge/level detect 0: falling/low 1: rising/high	C7IL 0	C6IL 0	C5IL 0	C4IL 0	C3IL 0	C2IL 0	C1IL 0	C0IL 0
0x28	GPIO_INT_LVL3	GPIO edge/level detect 0: falling/low 1: rising/high	N/A 0	N/A 0	N/A 0	N/A 0	N/A 0	N/A 0	C9IL 0	C8IL 0
0x29	DEBOUNCE_DIS1	Debounce disable 0: debounce enabled 1: debounce disabled	R7DD 0	R6DD 0	R5DD 0	R4DD 0	R3DD 0	R2DD 0	R1DD 0	R0DD 0
0x2A	DEBOUNCE_DIS2	Debounce disable 0: debounce enabled 1: debounce disabled	C7DD 0	C6DD 0	C5DD 0	C4DD 0	C3DD 0	C2DD 0	C1DD 0	C0DD 0
0x2B	DEBOUNCE_DIS3	Debounce disable 0: debounce enabled 1: debounce disabled	N/A 0	N/A 0	N/A 0	N/A 0	N/A 0	N/A 0	C9DD 0	C8DD 0
0x2C	GPIO_PULL1	GPIO pull-up disable 0: pull-up enabled 1: pull-up disabled	R7PD 0	R6PD 0	R5PD 0	R4PD 0	R3PD 0	R2PD 0	R1PD 0	R0PD 0
0x2D	GPIO_PULL2	GPIO pull-up disable 0: pull-up enabled 1: pull-up disabled	C7PD 0	C6PD 0	C5PD 0	C4PD 0	C3PD 0	C2PD 0	C1PD 0	C0PD 0
0x2E	GPIO_PULL3	GPIO pull-up disable 0: pull-up enabled 1: pull-up disabled	N/A 0	N/A 0	N/A 0	N/A 0	N/A 0	N/A 0	C9PD 0	C8PD 0
0x2F	Reserved									

8.6.2.1 Configuration Register (Address 0x01)

BIT	NAME	DESCRIPTION
7	AI	Auto-increment for read and write operations; See below table for more information 0 = disabled 1 = enabled
6	GPI_E_CFG	GPI event mode configuration 0 = GPI events are tracked when keypad is locked 1 = GPI events are not tracked when keypad is locked
5	OVR_FLOW_M	Overflow mode 0 = disabled; Overflow data is lost 1 = enabled; Overflow data shifts with last event pushing first event out
4	INT_CFG	Interrupt configuration 0 = processor interrupt remains asserted (or low) if host tries to clear interrupt while there is still a pending key press, key release or GPI interrupt 1 = processor interrupt is deasserted for 50 μ s and reassert with pending interrupts
3	OVR_FLOW_IEN	Overflow interrupt enable 0 = disabled; $\overline{\text{INT}}$ is not asserted if the FIFO overflows 1 = enabled; $\overline{\text{INT}}$ becomes asserted if the FIFO overflows
2	K_LCK_IEN	Keypad lock interrupt enable 0 = disabled; $\overline{\text{INT}}$ is not asserted after a correct unlock key sequence 1 = enabled; $\overline{\text{INT}}$ becomes asserted after a correct unlock key sequence
1	GPI_IEN	GPI interrupt enable to host processor 0 = disabled; $\overline{\text{INT}}$ is not asserted for a change on a GPI 1 = enabled; $\overline{\text{INT}}$ becomes asserted for a change on a GPI
0	KE_IEN	Key events interrupt enable to host processor 0 = disabled; $\overline{\text{INT}}$ is not asserted when a key event occurs 1 = enabled; $\overline{\text{INT}}$ becomes asserted when a key event occurs

Bit 7 in this register is used to determine the programming mode. If it is low, all data bytes are written to the register defined by the command byte. If bit 7 is high, the value of the command byte is automatically incremented after each byte is written, and the next data byte is stored in the corresponding register. Registers are written in the sequence shown in [Table 9](#). Once the GPIO_PULL3 register (0x2E) is written to, the command byte returns to register 0. Registers 0 and 2F are reserved and a command byte that references these registers is not acknowledged by the TCA8418.

The keypad lock interrupt enable determines if the interrupt pin is asserted when the key lock interrupt (see [Interrupt Status Register](#)) bit is set.

8.6.2.2 Interrupt Status Register, INT_STAT (Address 0x02)

BIT	NAME	DESCRIPTION
7	N/A	Always 0
6	N/A	Always 0
5	N/A	Always 0
4	CAD_INT	CTRL-ALT-DEL key sequence status. Requires writing a 1 to clear interrupts. 0 = interrupt not detected 1 = interrupt detected
3	OVR_FLOW_INT	Overflow interrupt status. Requires writing a 1 to clear interrupts. 0 = interrupt not detected 1 = interrupt detected
2	K_LCK_INT	Keypad lock interrupt status. This is the interrupt to the processor when the keypad lock sequence is started. Requires writing a 1 to clear interrupts. 0 = interrupt not detected 1 = interrupt detected
1	GPI_INT	GPI interrupt status. Requires writing a 1 to clear interrupts. 0 = interrupt not detected 1 = interrupt detected Can be used to mask interrupts
0	K_INT	Key events interrupt status. Requires writing a 1 to clear interrupts. 0 = interrupt not detected 1 = interrupt detected

The INT_STAT register is used to check which type of interrupt has been triggered. If the corresponding interrupt enable bits are set in the [Configuration Register](#), then a value of 1 in the corresponding bit will assert the $\overline{\text{INT}}$ line low. An exception to this is the CAD_INT bit, which will assert the CAD_INT pin on YFP packages.

A read to this register will return which types of events have occurred. Writing a 1 to the bit will clear the interrupt, unless there is still data which has set the Interrupt (unread keys in the FIFO).

8.6.2.3 Key Lock and Event Counter Register, KEY_LCK_EC (Address 0x03)

BIT	NAME	DESCRIPTION
7	N/A	Always 0
6	K_LCK_EN	Key lock enable 0 = disabled; Write a 0 to this bit to unlock the keypad manually 1 = enabled; Write a 1 to this bit to lock the keypad
5	LCK2	Keypad lock status 0 = unlock (if LCK1 is 0 too) 1 = locked (if LCK1 is 1 too)
4	LCK1	Keypad lock status 0 = unlock (if LCK2 is 0 too) 1 = locked (if LCK2 is 1 too)
3	KEC3 ⁽¹⁾	Key event count, Bit 3
2	KEC2	Key event count, Bit 2
1	KEC1	Key event count, Bit 1
0	KEC0	Key event count, Bit 0

(1) KEC[3:0] indicates how many key events are in the FIFO. For example, KEC[3:0] = 0b0000 = 0 events, KEC[3:0] = 0b0001 = 1 event and KEC[3:0] = 0b1010 = 10 events. As events happen (press or release), the count increases accordingly.

8.6.2.4 Key Event Registers (FIFO), KEY_EVENT_A–J (Address 0x04–0x0D)

ADDRESS	REGISTER NAME ⁽¹⁾	REGISTER DESCRIPTION	BIT							
			7	6	5	4	3	2	1	0
0x04	KEY_EVENT_A	Key event register A	KEA7	KEA6	KEA5	KEA4	KEA3	KEA2	KEA1	KEA0

(1) Only KEY_EVENT_A register is shown

These registers – KEY_EVENT_A–J – function as a FIFO stack which can store up to 10 key presses and releases. The user first checks the INT_STAT register to see if there are any interrupts. If so, then the Key Lock and Event Counter Register (KEY_LCK_EC, register 0x03) is read to see how many interrupts are stored. The INT_STAT register is then read again to ensure no new events have come in. The KEY_EVENT_A register is then read as many times as there are interrupts. Each time a read happens, the count in the KEY_LCK_EC register reduces by 1. The data in the FIFO also moves down the stack by 1 too (from KEY_EVENT_J to KEY_EVENT_A). Once all events have been read, the key event count is at 0 and then KE_INT bit can be cleared by writing a '1' to it.

In the KEY_EVENT_A register, KEA[6:0] indicates the key # pressed or released. A value of 0 to 80 indicate which key has been pressed or released in a keypad matrix. Values of 97 to 114 are for GPI events.

Bit 7 or KEA[7] indicate if a key press or key release has happened. A '0' means a key release happened. A '1' means a key has been pressed (which can be cleared on a read).

For example, 3 key presses and 3 key releases are stored as 6 words in the FIFO. As each word is read, the user knows if it is a key press or key release that occurred. Key presses such as CTRL+ALT+DEL are stored as 3 simultaneous key presses. Key presses and releases generate key event interrupts. The KE_INT bit and /INT pin will not cleared until the FIFO is cleared of all events.

All registers can be read but for the purpose of the FIFO, the user should only read KEY_EVENT_A register. Once all the events in the FIFO have been read, reading of KEY_EVENT_A register will yield a zero value.

8.6.2.5 Keypad Lock1 to Lock2 Timer Register, KP_LCK_TIMER (Address 0x0E)

ADDRESS	REGISTER NAME	REGISTER DESCRIPTION	BIT							
			7	6	5	4	3	2	1	0
0x0E	KP_LCK_TIMER	Keypad lock interrupt mask timer and lock 1 to lock 2 timer	KL7	KL6	KL5	KL4	KL3	KL2	KL1	KL0

KL[2:0] are for the Lock1 to Lock2 timer

KL[7:3] are for the interrupt mask timer

Lock1 to Lock2 timer must be non-zero for keylock to be enabled. The lock1 to lock2 bits (KL[2:0]) define the time in seconds the user has to press unlock key 2 after unlock key 1 before the key lock sequence times out. For more information, please see [Keypad Lock/Unlock](#).

If the keypad lock interrupt mask timer is non-zero, a key event interrupt (K_INT) will be generated on any first key press. The second interrupt (K_LCK_IN) will only be generated when the correct unlock sequence has been completed. If either timer expires, the keylock state machine will reset.

When the interrupt mask timer is disabled ('0'), a key lock interrupt will trigger only when the correct unlock sequence is completed.

The interrupt mask timer should be set for the time it takes for the LCD to dim or turn off. For more information, please see [Keypad Lock Interrupt Mask Timer](#).

8.6.2.6 Unlock1 and Unlock2 Registers, UNLOCK1/2 (Address 0x0F-0x10)

ADDRESS	REGISTER NAME	REGISTER DESCRIPTION	BIT							
			7	6	5	4	3	2	1	0
0x0F	Unlock1	Unlock key 1	UK1_7	UK1_6	UK1_5	UK1_4	UK1_3	UK1_2	UK1_1	UK1_0
0x10	Unlock2	Unlock key 2	UK2_7	UK2_6	UK2_5	UK2_4	UK2_3	UK2_2	UK2_1	UK2_0

UK1[6:0] contains the key number used to unlock key 1

UK2[6:0] contains the key number used to unlock key 2

A '0' in either register disables the keylock function.

8.6.2.7 GPIO Interrupt Status Registers, GPIO_INT_STAT1–3 (Address 0x11–0x13)

These registers are used to check GPIO interrupt status. If the GPI_INT bit is set in [INT_STAT](#) register, then the GPI which set the interrupt is marked with a 1 in the corresponding table. To clear the GPI_INT bit, these registers must all be 0x00. A read to the register clears the bit.

ADDRESS	REGISTER NAME	REGISTER DESCRIPTION	BIT							
			7	6	5	4	3	2	1	0
0x11	GPIO_INT_STAT1	GPIO Interrupt Status 1	R7IS	R6IS	R5IS	R4IS	R3IS	R2IS	R1IS	R0IS
0x12	GPIO_INT_STAT2	GPIO Interrupt Status 2	C7IS	C6IS	C5IS	C4IS	C3IS	C2IS	C1IS	C0IS
0x13	GPIO_INT_STAT3	GPIO Interrupt Status 3	N/A	N/A	N/A	N/A	N/A	N/A	C9IS	C8IS

8.6.2.8 GPIO Data Status Registers, GPIO_DAT_STAT1–3 (Address 0x14–0x16)

These registers show the GPIO state when read for inputs and outputs. Read these twice to clear them.

If debouncing is enabled, these registers return their default values until a change of state occurs at an input. Initial pin states can be read by disabling debouncing.

ADDRESS	REGISTER NAME	REGISTER DESCRIPTION	BIT							
			7	6	5	4	3	2	1	0
0x14	GPIO_DAT_STAT1	GPIO Data Status 1	R7DS	R6DS	R5DS	R4DS	R3DS	R2DS	R1DS	R0DS
0x15	GPIO_DAT_STAT2	GPIO Data Status 2	C7DS	C6DS	C5DS	C4DS	C3DS	C2DS	C1DS	C0DS
0x16	GPIO_DAT_STAT3	GPIO Data Status 3	N/A	N/A	N/A	N/A	N/A	N/A	C9DS	C8DS

8.6.2.9 GPIO Data Out Registers, GPIO_DAT_OUT1–3 (Address 0x17–0x19)

These registers contain GPIO data to be written to GPIO out driver; inputs are not affected. This sets the output for the corresponding GPIO output.

ADDRESS	REGISTER NAME	REGISTER DESCRIPTION	BIT							
			7	6	5	4	3	2	1	0
0x17	GPIO_DAT_OUT1	GPIO Data Out 1	R7DO	R6DO	R5DO	R4DO	R3DO	R2DO	R1DO	R0DO
0x18	GPIO_DAT_OUT2	GPIO Data Out 2	C7DO	C6DO	C5DO	C4DO	C3DO	C2DO	C1DO	C0DO
0x19	GPIO_DAT_OUT3	GPIO Data Out 3	N/A	N/A	N/A	N/A	N/A	N/A	C9DO	C8DO

8.6.2.10 GPIO Interrupt Enable Registers, GPIO_INT_EN1–3 (Address 0x1A–0x1C)

These registers enable interrupts (bit value 1) or disable interrupts (bit value '0') for general purpose inputs (GPI) only. If the input changes on a pin which is setup as a GPI, then the GPI_INT bit will be set in the [INT_STAT](#) register.

A bit value of '0' in any of the unreserved bits disables the corresponding pin's ability to generate an interrupt when the state of the input changes. This is the default value.

A bit value of 1 in any of the unreserved bits enables the corresponding pin's ability to generate an interrupt when the state of the input changes.

ADDRESS	REGISTER NAME	REGISTER DESCRIPTION	BIT							
			7	6	5	4	3	2	1	0
0x1A	GPIO_INT_EN1	GPIO Interrupt Enable 1	R7IE	R6IE	R5IE	R4IE	R3IE	R2IE	R1IE	R0IE
0x1B	GPIO_INT_EN2	GPIO Interrupt Enable 2	C7IE	C6IE	C5IE	C4IE	C3IE	C2IE	C1IE	C0IE
0x1C	GPIO_INT_EN3	GPIO Interrupt Enable 3	N/A	N/A	N/A	N/A	N/A	N/A	C9IE	C8IE

8.6.2.11 Keypad or GPIO Selection Registers, KP_GPIO1–3 (Address 0x1D–0x1F)

A bit value of '0' in any of the unreserved bits puts the corresponding pin in GPIO mode. A pin in GPIO mode can be configured as an input or an output in the [GPIO_DIR1-3](#) registers. This is the default value.

A 1 in any of these bits puts the pin in key scan mode and becomes part of the keypad array, then it is configured as a row or column accordingly (this is not adjustable).

ADDRESS	REGISTER NAME	REGISTER DESCRIPTION	BIT							
			7	6	5	4	3	2	1	0
0x1D	KP_GPIO1	Keypad/GPIO Select 1	ROW7	ROW6	ROW5	ROW4	ROW3	ROW2	ROW1	ROW0
0x1E	KP_GPIO2	Keypad/GPIO Select 2	COL7	COL6	COL5	COL4	COL3	COL2	COL1	COL0
0x1F	KP_GPIO3	Keypad/GPIO Select 3	N/A	N/A	N/A	N/A	N/A	N/A	COL9	COL8

8.6.2.12 GPI Event Mode Registers, GPI_EM1–3 (Address 0x20–0x22)

A bit value of '0' in any of the unreserved bits indicates that it is not part of the event FIFO. This is the default value.

A 1 in any of these bits means it is part of the event FIFO. When a pin is setup as a GPI and has a value of 1 in the Event Mode register, then any key presses will be added to the FIFO. Please see [Key Event Table](#) for more information.

ADDRESS	REGISTER NAME	REGISTER DESCRIPTION	BIT							
			7	6	5	4	3	2	1	0
0x20	GPI_EM1	GPI Event Mode Select 1	ROW7	ROW6	ROW5	ROW4	ROW3	ROW2	ROW1	ROW0
0x21	GPI_EM2	GPI Event Mode Select 2	COL7	COL6	COL5	COL4	COL3	COL2	COL1	COL0
0x23	GPI_EM3	GPI Event Mode Select 3	N/A	N/A	N/A	N/A	N/A	N/A	COL9	COL8

8.6.2.13 GPIO Data Direction Registers, GPIO_DIR1–3 (Address 0x23–0x25)

A bit value of '0' in any of the unreserved bits sets the corresponding pin as an input. This is the default value.

A 1 in any of these bits sets the pin as an output.

ADDRESS	REGISTER NAME	REGISTER DESCRIPTION	BIT							
			7	6	5	4	3	2	1	0
0x23	GPIO_DIR1	GPIO Direction 1	R7DD	R6DD	R5DD	R4DD	R3DD	R2DD	R1DD	R0DD
0x24	GPIO_DIR2	GPIO Direction 2	C7DD	C6DD	C5DD	C4DD	C3DD	C2DD	C1DD	C0DD
0x25	GPIO_DIR3	GPIO Direction 3	N/A	N/A	N/A	N/A	N/A	N/A	C9DD	C8DD

8.6.2.14 GPIO Edge/Level Detect Registers, GPIO_INT_LVL1–3 (Address 0x26–0x28)

A bit value of '0' indicates that interrupt will be triggered on a high-to-low/low-level transition for the inputs in GPIO mode. This is the default value.

A bit value of 1 indicates that interrupt will be triggered on a low-to-high/high-level value for the inputs in GPIO mode.

ADDRESS	REGISTER NAME	REGISTER DESCRIPTION	BIT							
			7	6	5	4	3	2	1	0
0x26	GPIO_INT_LVL1	GPIO Edge/Level Detect 1	R7IL	R6IL	R5IL	R4IL	R3IL	R2IL	R1IL	R0IL
0x27	GPIO_INT_LVL2	GPIO Edge/Level Detect 2	C7IL	C6IL	C5IL	C4IL	C3IL	C2IL	C1IL	C0IL
0x28	GPIO_INT_LVL3	GPIO Edge/Level Detect 3	N/A	N/A	N/A	N/A	N/A	N/A	C9IL	C8IL

8.6.2.15 Debounce Disable Registers, DEBOUNCE_DIS1–3 (Address 0x29–0x2B)

This is for pins configured as inputs. A bit value of '0' in any of the unreserved bits enables the debounce. This is the default value

A bit value of '1' disables the debounce.

ADDRESS	REGISTER NAME	REGISTER DESCRIPTION	BIT							
			7	6	5	4	3	2	1	0
0x29	DEBOUNCE_DIS1	Debounce Disable 1	R7DD	R6DD	R5DD	R4DD	R3DD	R2DD	R1DD	R0DD
0x30	DEBOUNCE_DIS2	Debounce Disable 2	C7DD	C6DD	C5DD	C4DD	C3DD	C2DD	C1DD	C0DD
0x2B	DEBOUNCE_DIS3	Debounce Disable 3	N/A	N/A	N/A	N/A	N/A	N/A	C9DD	C8DD

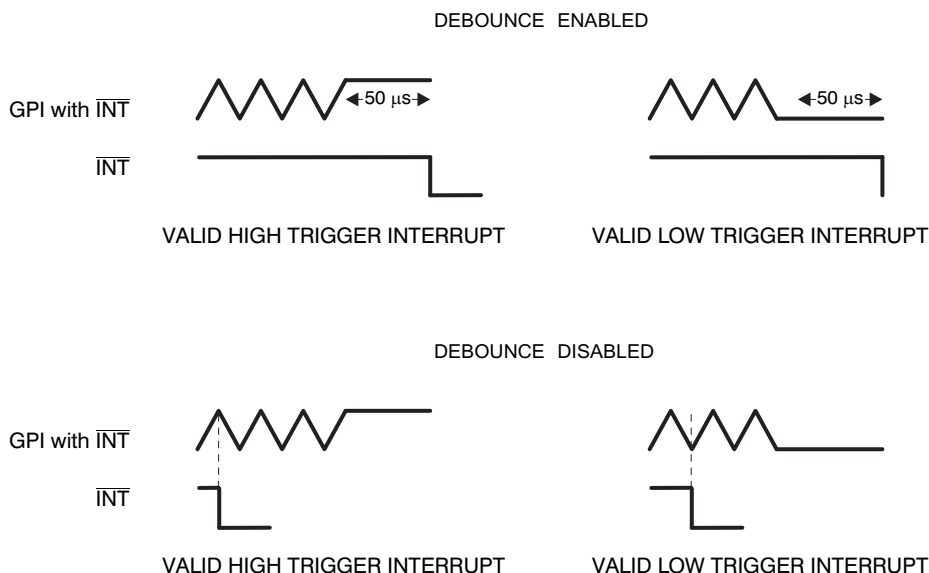

Debounce disable will have the same effect for GPI mode or for rows in keypad scanning mode. The $\overline{\text{RESET}}$ input always has a 50- μs debounce time.

The debounce time for inputs is the time required for the input to be stable to be noticed. This time is 50 μs .

The debounce time for the keypad is for the columns only. The minimum time is 25 ms. All columns are scanned once every 25 ms to detect any key presses. Two full scans are required to see if any keys were pressed. If the first scan is done just after a key press, it takes 25 ms to detect the key press. If the first scan is done much later than the key press, it will take 40 ms to detect a key press.

8.6.2.16 GPIO pull-up Disable Register, GPIO_PULL1–3 (Address 0x2C–0x2E)

This register enables or disables pull-up registers from inputs.

A bit value of '0' will enable the internal pull-up resistors. This is the default value.

A bit value of 1 will disable the internal pull-up resistors.

ADDRESS	REGISTER NAME	REGISTER DESCRIPTION	BIT							
			7	6	5	4	3	2	1	0
0x2C	GPIO_PULL1	GPIO pull-up Disable 1	R7PD	R6PD	R5PD	R4PD	R3PD	R2PD	R1PD	R0PD
0x3D	GPIO_PULL2	GPIO pull-up Disable 2	C7PD	C6PD	C5PD	C4PD	C3PD	C2PD	C1PD	C0PD
0x2E	GPIO_PULL3	GPIO pull-up Disable 3	N/A	N/A	N/A	N/A	N/A	N/A	C9PD	C8PD

8.6.3 CAD Interrupt Errata

8.6.3.1 Description

In the Interrupt Status Register (see [Table 10](#)), bit 4 is used to indicate the detection of a CTRL-ALT-DEL key sequence. Certain key press sequences trigger this bit to register a CAD_INT improperly.

Table 10. Interrupt Status Register, INT_STAT (Address 0x02)

BIT	NAME	DESCRIPTION
7	N/A	Always 0
6	N/A	Always 0
5	N/A	Always 0
4	CAD_INT	CTRL-ALT-DEL key sequence status. Requires writing a 1 to clear interrupts. 0 = interrupt not detected 1 = interrupt detected
3	OVR_FLOW_INT	Overflow interrupt status. Requires writing a 1 to clear interrupts. 0 = interrupt not detected 1 = interrupt detected
2	K_LCK_INT	Keypad lock interrupt status. This is the interrupt to the processor when the keypad lock sequence is started. Requires writing a 1 to clear interrupts. 0 = interrupt not detected 1 = interrupt detected
1	GPI_INT	GPI interrupt status. Requires writing a 1 to clear interrupts. 0 = interrupt not detected 1 = interrupt detected Can be used to mask interrupts
0	K_INT	Key events interrupt status. Requires writing a 1 to clear interrupts. 0 = interrupt not detected 1 = interrupt detected

The following key press combinations will cause a false CAD_INT:

- 1 + 11
- 1 + 21
- 21 + 1 + 11

8.6.3.2 System Impact

This device has an individual pin for the CAD_INT unlike the TCA8418. The CAD_INT pin falsely flag the processor in addition to the Interrupt Status Register's CAD_INT bit being High when a CAD sequence did not occur.

8.6.3.3 System Workaround

There is no system workaround to avoid the Interrupt Status Register to indicate a CAD_INT sequence being detected.

8.6.4 Overflow Errata

8.6.4.1 Description

The TCA8418 allows for overflow detection of the 10 byte FIFO of key-press and release events. For overflow to be enabled, both Bit_3 and Bit_5 of the Configuration Register (see [Table 11](#)) must be set High. If only Bit_3 set high, no overflow interrupt is generated.

Table 11. Configuration Register (Address 0x01)

BIT	NAME	DESCRIPTION
7	AI	Auto-increment for read and write operation 0 = disabled 1 = enabled
6	CPI_E_CFG	GPI even mode configuration 0 = GPI events are tracked when keypad is locked 1 = GPI events are not tracked when keypad is locked
5	OVR_FLOW_M	Overflow mode 0 = disabled; overflow data is lost 1 = enabled.
4	INT_CFG	Overflow data shifts with last event pushing first event out interrupt configuration. 0 = processor interrupt remains asserted (or low) if host tries to clear interrupt while there is still a pending key press, key release or GPI interrupt 1 = processor interrupt is deasserted for 50 μ s and reassert with pending interrupts
3	OVR_FLOW_IEN	Overflow interrupt enable 0 = disabled 1 = enabled
2	K_LCK_IEN	Keypad lock interrupt enable 0 = disabled 1 = enabled

8.6.4.2 System Impact

Enabling the Overflow improperly may lead to data loss.

8.6.4.3 System Workaround

The FIFO stack should be read as new information is passed in. Since the Overflow interrupt is triggered once that stack has begun to overflow, meaning data is already being lost.

9 Application and Implementation

NOTE

Information in the following applications sections is not part of the TI component specification, and TI does not warrant its accuracy or completeness. TI's customers are responsible for determining suitability of components for their purposes. Customers should validate and test their design implementation to confirm system functionality.

9.1 Application Information

9.1.1 Ghosting Considerations

The TCA8418 supports multiple key presses accurately. Applications requiring three-key combinations (such as <Ctrl><Alt>, or any other combinations) must ensure that the three keys are wired in appropriate key positions to avoid ghosting (or appearing like a 4th key has been pressed).

To avoid ghosting, it is best to keep 3-button combinations that are pressed on separate rows and columns. Consider the situation with the keypad described in [Figure 26](#).

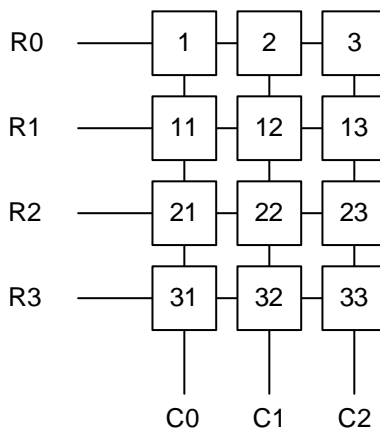

Figure 26. Example Keypad

In the keypad setup in [Figure 26](#), there is a 4x3 keypad matrix, connected to ROW0-ROW3, and COL0-COL2. All of the ROWs are configured as inputs with pullup resistors. The COLs are configured as outputs, driving low. When a key press is made, one of the ROW inputs will be pulled low, letting the TCA8418 know that a key has been pressed, and the TCA8418 will then start the key scanning algorithm. During this algorithm, it sweeps the output low across the columns, such that only 1 column is driven low at a time. While this is done to each column, the TCA8418 will read the ROW inputs, to determine which keys on a column are being pressed.

Ghosting can occur when multiple keys are pressed that can make it appear that additional keys (which are not being pressed) are being pressed.

Application Information (continued)

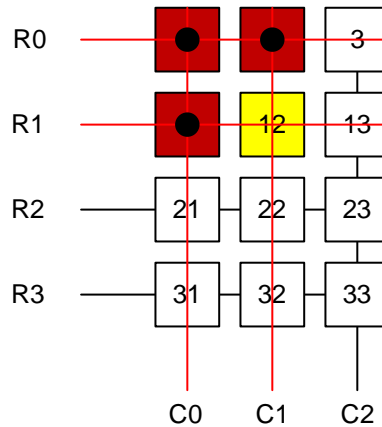

Figure 27. Incorrect 3 Button Combination

In [Figure 27](#), keys 1, 2, and 11 are pressed, which causes a ghosting issue. Since R1 becomes pulled to ground through key 1 (which is pulled through key 2 when C1 is transmitting a low), when C1 is driving low, the TCA8418 will see a low signal at both R0 and R1. This will falsely trigger key 12 as being pressed (the key highlighted as yellow).

The reason for this is that keypad matrices will short the columns to the rows connected together. When C1 is driving low, the low gets transmitted onto R0 via key 2. Key 1 is being pressed, which also shorts C0 to ground. Key 11 is pressed, which then shorts R1 to C0. In this process, R1 is shorted to C1, which is the reason ghosting occurs.

Keypad matrices can support multiple key presses properly, if care is taken when choosing the layout. In [Figure 28](#), we see a 3 button combination which work as expected. Keys 1, 11, and 21 are pressed (this also is the combination that will set the <Ctrl><Alt> interrupt, see [Control-Alt-Delete Support](#) for more information).

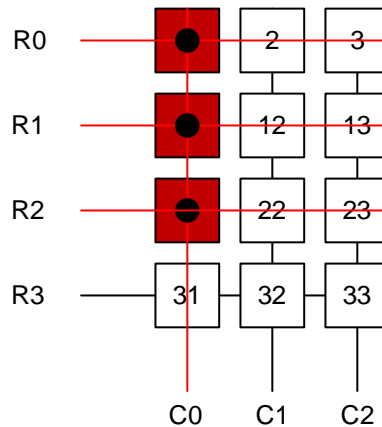

Figure 28. Correct 3 Button Combination

9.2 Typical Application

Figure 29 shows a typical application of the TCA8418. In this specific example, a common 12 key number pad layout is used. This number pad has keys for numbers 0 to 9, *, and #.

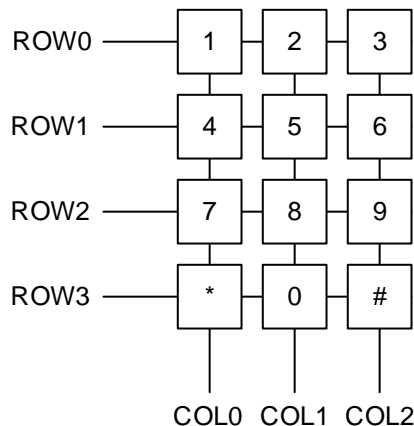

Figure 29. Typical Application

9.2.1 Design Requirements

The system designer needs to know a few key pieces in order to design their system for the TCA8418.

- The number of keys desired
- Whether the keys will be multiplexed or not
- The layout of the multiplexed keys
- Unused keys be tied to VCC through a pullup resistor (10 kΩ)

9.2.2 Detailed Design Procedure

9.2.2.1 Designing the Hardware Layout

The first steps towards designing a keypad array is to determine the desired layout, and to map each key to the appropriate value which will show up in the FIFO. For this example, the number pad below is the physical location of the keys that are desired. The layout is a 4 x 3 array, using rows 0-3 and columns 0-2. For this example, we will not assume any of the other pins will be used.

The following behavior is desired for this example design

- All keys in the keypad array to be added to the FIFO upon a key press
- Attempting to clear the interrupt before the proper registers have been cleared to de-assert the $\overline{\text{INT}}$ pin for 50 μs , then assert the INT pin.
- No additional pins are being used, other than the keypad array
- Keypad lock support, requiring that the unlock combination be '#, 1' which must be pressed within 2 seconds of each other
- Keypad lock interrupt mask timer of 10 seconds to match the back light auto-turn off with 10 seconds of no interrupt
- Hardware debouncing to be enabled

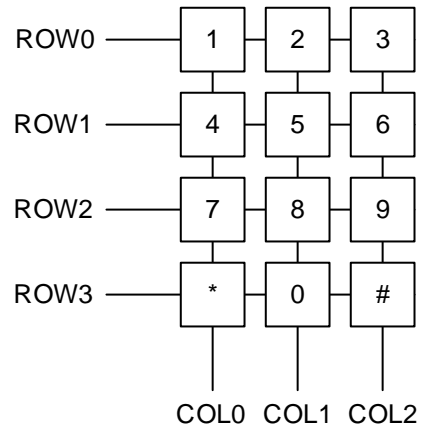
Typical Application (continued)

Figure 30. Example Keypad

Since the TCA8418 reports keys pressed according to the values in the key value table, it is important to know the TCA8418 values for the key locations.

According to the key event table, the key presses are assigned in [Table 12](#).

Table 12. Key Press Assignment

Keypad Button	1	2	3	4	5	6	7	8	9	*	0	#
Key Event Table Value (Decimal)	1	2	3	11	12	13	21	22	23	31	32	33

The schematic for this keypad layout is shown in *figure (schematic below)* with the key event table values. Note that no external pullup resistors are needed, because the TCA8418 has integrated pullup resistors.

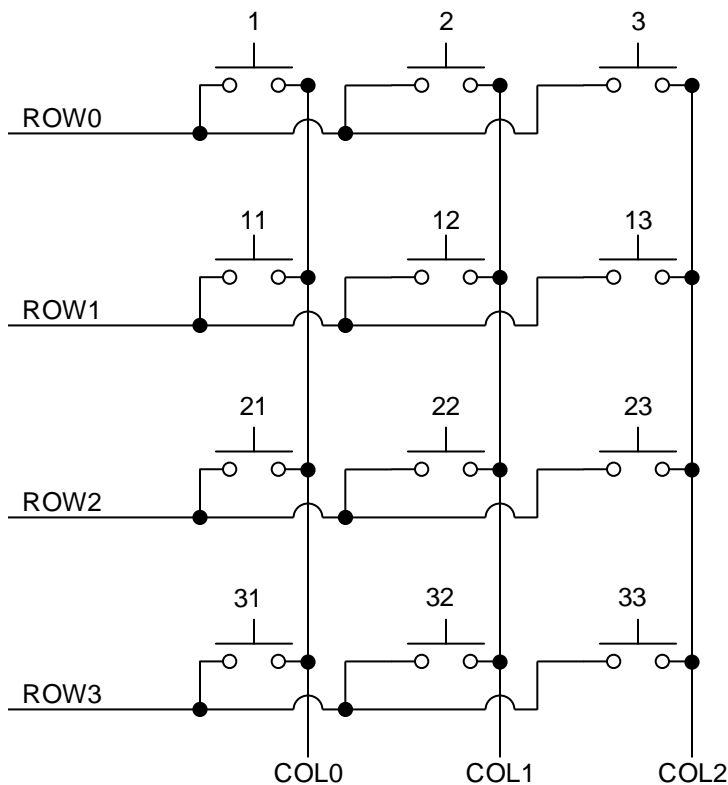

Figure 31. Keypad Schematic

9.2.2.2 Configuring the Registers

The next step to design a keypad array for the TCA8418 is to configure the appropriate hardware registers.

The registers that must be modified for the desired features are the following

STEP	REGISTER TO EDIT	VALUE TO WRITE	DESCRIPTION
Setup keypad array	KP_GPIO1 (0x1D)	0x0F	Set ROW0-ROW3 to KP Matrix
	KP_GPIO2 (0x1E)	0x07	Set COL0-COL2 to KP Matrix
	KP_GPIO3 (0x1F)	0x00	Set COL8-COL9 to GPIO
Setup Interrupts	CFG (0x01)	0x95	Set the KE_IEN, K_LCK_IEN, INT_CFG, and AI bits
Setup Unlock Key Combination	UNLOCK1 (0x0F)	0x21	Set first unlock key to key 33
	UNLOCK2 (0x10)	0x01	Set second unlock key to key 1
Set Keypad Lock Timers	KP_LCK_TIMER (0x0E)	0x52	Lock1 to Lock2 set to 2 seconds. Interrupt mask timer set to 10 seconds

9.2.3 Application Curves

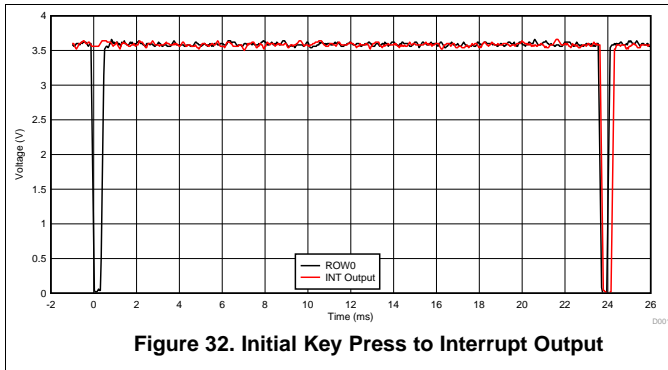

Figure 32. Initial Key Press to Interrupt Output

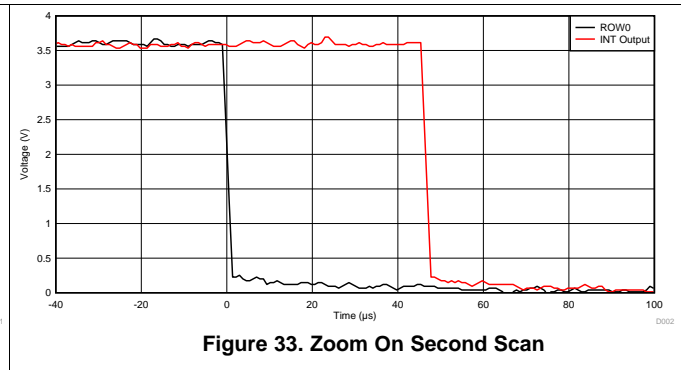

Figure 33. Zoom On Second Scan

10 Power Supply Recommendations

In the event of a glitch or data corruption, TCA8418 can be reset to its default conditions by using the power-on reset feature. Power-on reset requires that the device go through a power cycle to be completely reset. This reset also happens when the device is powered on for the first time in an application.

The two types of power-on reset are shown in Figure 34 and Figure 35.

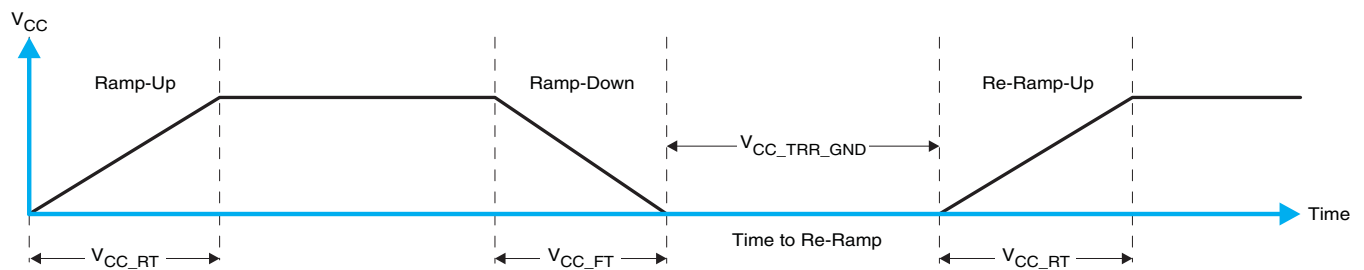

Figure 34. V_{CC} is Lowered Below 0.2 V or 0 V and Then Ramped Up to V_{CC}

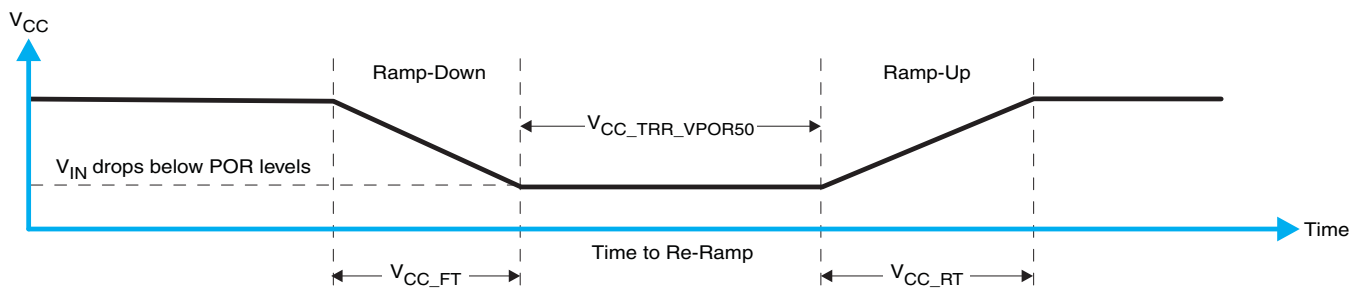

Figure 35. V_{CC} is Lowered Below the POR Threshold, Then Ramped Back Up to V_{CC}

Table 13 specifies the performance of the power-on reset feature for TCA8418 for both types of power-on reset.

Table 13. Recommended Supply Sequencing and Ramp Rates⁽¹⁾

PARAMETER			MIN	TYP	MAX	UNIT
V_{CC_FT}	Fall rate	See Figure 34	1		100	ms
V_{CC_RT}	Rise rate	See Figure 34	0.01		100	ms
$V_{CC_TRR_GND}$	Time to re-ramp (when V_{CC} drops to GND)	See Figure 34	0.001			ms
$V_{CC_TRR_POR50}$	Time to re-ramp (when V_{CC} drops to $V_{POR_MIN} - 50$ mV)	See Figure 35	0.001			ms

(1) $T_A = -40^{\circ}\text{C}$ to 85°C (unless otherwise noted)

Table 13. Recommended Supply Sequencing and Ramp Rates⁰ (continued)

PARAMETER		MIN	TYP	MAX	UNIT
V_{CC_GH}	Level that V_{CC} can glitch down to, but not cause a functional disruption when $V_{CC_GW} = 1 \mu s$			1.2	V
V_{CC_GW}	Glitch width that will not cause a functional disruption when $V_{CC_GH} = 0.5 \times V_{CCx}$			10	μs
V_{PORF}	Voltage trip point of POR on falling V_{CC}	0.76		1.15	V
V_{PORR}	Voltage trip point of POR on rising V_{CC}	1.03		1.43	V

Glitches in the power supply can also affect the power-on reset performance of this device. The glitch width (V_{CC_GW}) and height (V_{CC_GH}) are dependent on each other. The bypass capacitance, source impedance, and device impedance are factors that affect power-on reset performance. Figure 36 and Table 13 provide more information on how to measure these specifications.



Figure 36. Glitch Width and Glitch Height

V_{POR} is critical to the power-on reset. V_{POR} is the voltage level at which the reset condition is released and all the registers and the I²C/SMBus state machine are initialized to their default states. The value of V_{POR} differs based on the V_{CC} being lowered to or from 0. Figure 37 and Table 13 provide more details on this specification.

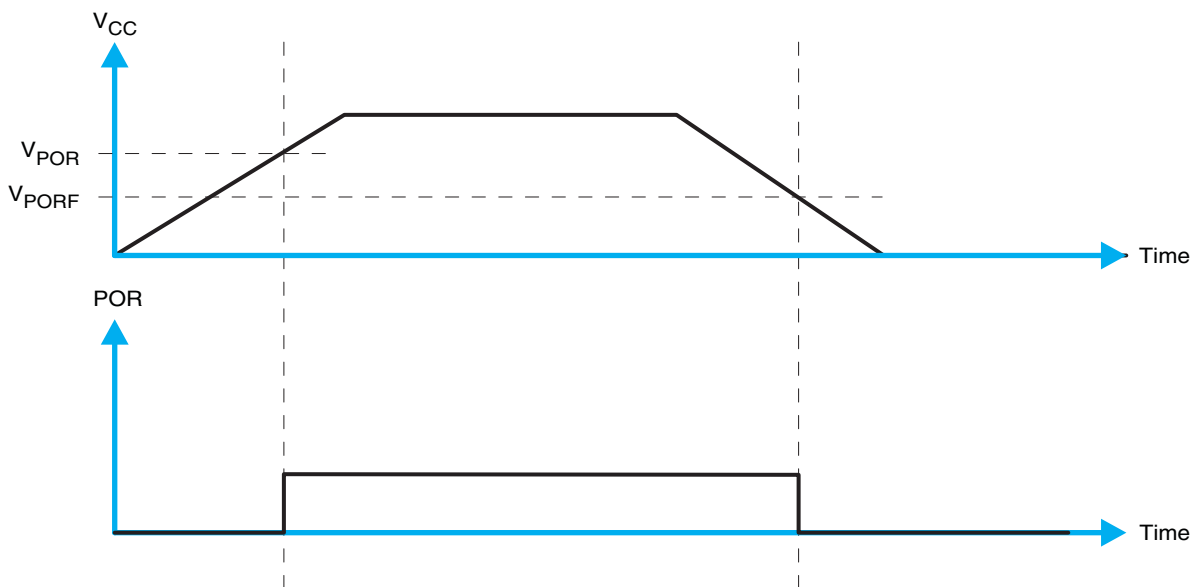

Figure 37. V_{POR}

For proper operation of the power-on reset feature, use as directed in the previous figures and table above.

11 Layout

11.1 Layout Guidelines

For printed circuit board (PCB) layout of the TCA8418, common PCB layout practices should be followed, but additional concerns related to high-speed data transfer, such as matched impedances and differential pairs are not a concern for I²C signal speeds.

In all PCB layouts, it is best practice to avoid right angles in signal traces, to fan out signal traces away from each other upon leaving the vicinity of an integrated circuit (IC), and to use thicker trace widths to carry higher amounts of current that commonly pass through power and ground traces. Bypass and de-coupling capacitors are commonly used to control the voltage on the VCC pin, using a larger capacitor to provide additional power in the event of a short power supply glitch and a smaller capacitor to filter out high-frequency ripple. These capacitors should be placed as close to the TCA8418 as possible.

For the layout example provided in [Layout Example](#), a 4 layer board is required to route all of the signals. The layout example shows a way to route the signals out from the device, which can eventually be brought up to the top layer (or any required layer) with the use of a via. This technique is not demonstrated in this example due to the complexity of the layout.

11.2 Layout Example

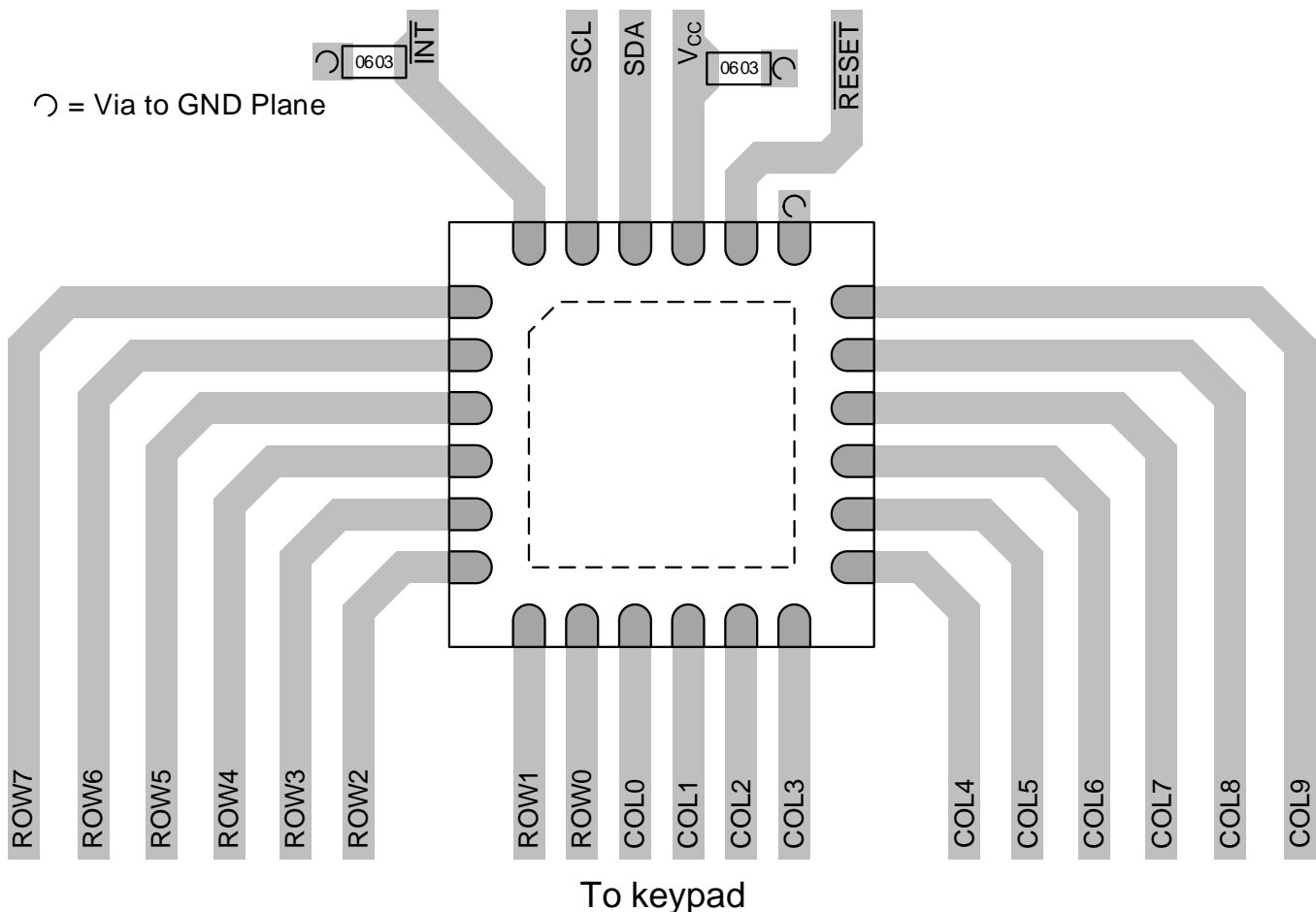

Figure 38. RTW Package Layout Example

12 器件和文档支持

12.1 接收文档更新通知

要接收文档更新通知，请导航至 TI.com.cn 上的器件产品文件夹。单击右上角的 [通知我](#) 进行注册，即可每周接收产品信息更改摘要。有关更改的详细信息，请查阅已修订文档中包含的修订历史记录

12.2 社区资源

下列链接提供到 TI 社区资源的连接。链接的内容由各个分销商“按照原样”提供。这些内容并不构成 TI 技术规范，并且不一定反映 TI 的观点；请参阅 TI 的 [《使用条款》](#)。

TI E2E™ 在线社区 [TI 的工程师对工程师 \(E2E\) 社区](#)。此社区的创建目的在于促进工程师之间的协作。在 e2e.ti.com 中，您可以咨询问题、分享知识、拓展思路并与同行工程师一道帮助解决问题。

设计支持 [TI 参考设计支持](#) 可帮助您快速查找有帮助的 E2E 论坛、设计支持工具以及技术支持的联系信息。

12.3 商标

E2E is a trademark of Texas Instruments.
All other trademarks are the property of their respective owners.

12.4 静电放电警告



这些装置包含有限的内置 ESD 保护。存储或装卸时，应将导线一起截短或将装置放置于导电泡棉中，以防止 MOS 门极遭受静电损伤。

12.5 术语表

[SLYZ022](#) — *TI 术语表*。

这份术语表列出并解释术语、缩写和定义。

13 机械、封装和可订购信息

以下页面包含机械、封装和可订购信息。这些信息是指定器件的最新可用数据。数据如有变更，恕不另行通知，且不会对此文档进行修订。如需获取此产品说明书的浏览器版本，请参阅左侧的导航栏。

PACKAGING INFORMATION

Orderable part number	Status (1)	Material type (2)	Package Pins	Package qty Carrier	RoHS (3)	Lead finish/ Ball material (4)	MSL rating/ Peak reflow (5)	Op temp (°C)	Part marking (6)
TCA8418RTWR	Active	Production	WQFN (RTW) 24	3000 LARGE T&R	Yes	NIPDAU	Level-2-260C-1 YEAR	-40 to 85	PZ418
TCA8418RTWR.A	Active	Production	WQFN (RTW) 24	3000 LARGE T&R	Yes	NIPDAU	Level-2-260C-1 YEAR	-40 to 85	PZ418
TCA8418RTWRG4	Active	Production	WQFN (RTW) 24	3000 LARGE T&R	Yes	NIPDAU	Level-2-260C-1 YEAR	-40 to 85	PZ418
TCA8418RTWRG4.A	Active	Production	WQFN (RTW) 24	3000 LARGE T&R	Yes	NIPDAU	Level-2-260C-1 YEAR	-40 to 85	PZ418

⁽¹⁾ **Status:** For more details on status, see our [product life cycle](#).

⁽²⁾ **Material type:** When designated, preproduction parts are prototypes/experimental devices, and are not yet approved or released for full production. Testing and final process, including without limitation quality assurance, reliability performance testing, and/or process qualification, may not yet be complete, and this item is subject to further changes or possible discontinuation. If available for ordering, purchases will be subject to an additional waiver at checkout, and are intended for early internal evaluation purposes only. These items are sold without warranties of any kind.

⁽³⁾ **RoHS values:** Yes, No, RoHS Exempt. See the [TI RoHS Statement](#) for additional information and value definition.

⁽⁴⁾ **Lead finish/Ball material:** Parts may have multiple material finish options. Finish options are separated by a vertical ruled line. Lead finish/Ball material values may wrap to two lines if the finish value exceeds the maximum column width.

⁽⁵⁾ **MSL rating/Peak reflow:** The moisture sensitivity level ratings and peak solder (reflow) temperatures. In the event that a part has multiple moisture sensitivity ratings, only the lowest level per JEDEC standards is shown. Refer to the shipping label for the actual reflow temperature that will be used to mount the part to the printed circuit board.

⁽⁶⁾ **Part marking:** There may be an additional marking, which relates to the logo, the lot trace code information, or the environmental category of the part.

Multiple part markings will be inside parentheses. Only one part marking contained in parentheses and separated by a "~" will appear on a part. If a line is indented then it is a continuation of the previous line and the two combined represent the entire part marking for that device.

Important Information and Disclaimer: The information provided on this page represents TI's knowledge and belief as of the date that it is provided. TI bases its knowledge and belief on information provided by third parties, and makes no representation or warranty as to the accuracy of such information. Efforts are underway to better integrate information from third parties. TI has taken and continues to take reasonable steps to provide representative and accurate information but may not have conducted destructive testing or chemical analysis on incoming materials and chemicals. TI and TI suppliers consider certain information to be proprietary, and thus CAS numbers and other limited information may not be available for release.

In no event shall TI's liability arising out of such information exceed the total purchase price of the TI part(s) at issue in this document sold by TI to Customer on an annual basis.

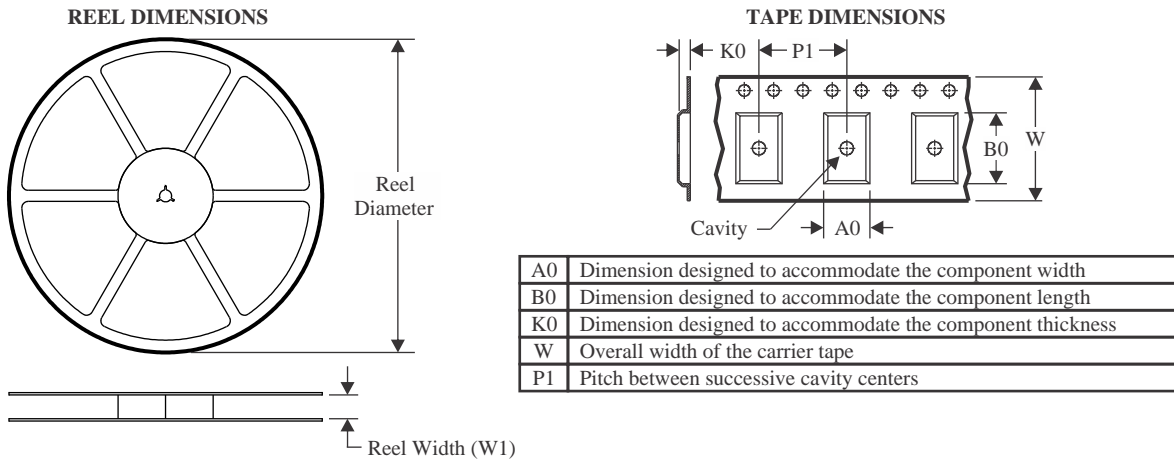
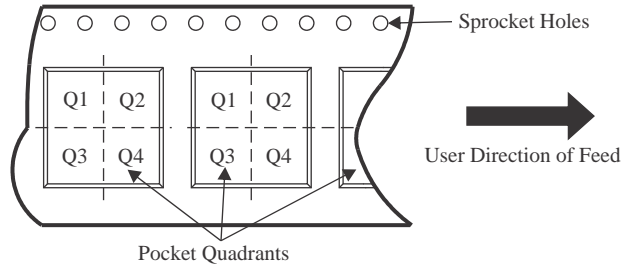
TAPE AND REEL INFORMATION

QUADRANT ASSIGNMENTS FOR PIN 1 ORIENTATION IN TAPE

*All dimensions are nominal

Device	Package Type	Package Drawing	Pins	SPQ	Reel Diameter (mm)	Reel Width W1 (mm)	A0 (mm)	B0 (mm)	K0 (mm)	P1 (mm)	W (mm)	Pin1 Quadrant
TCA8418RTWR	WQFN	RTW	24	3000	330.0	12.4	4.3	4.3	1.3	8.0	12.0	Q2
TCA8418RTWRG4	WQFN	RTW	24	3000	330.0	12.4	4.25	4.25	1.15	8.0	12.0	Q2

TAPE AND REEL BOX DIMENSIONS

*All dimensions are nominal

Device	Package Type	Package Drawing	Pins	SPQ	Length (mm)	Width (mm)	Height (mm)
TCA8418RTWR	WQFN	RTW	24	3000	356.0	356.0	36.0
TCA8418RTWRG4	WQFN	RTW	24	3000	367.0	367.0	35.0

GENERIC PACKAGE VIEW

RTW 24

WQFN - 0.8 mm max height

4 x 4, 0.5 mm pitch

PLASTIC QUAD FLATPACK - NO LEAD

This image is a representation of the package family, actual package may vary.
Refer to the product data sheet for package details.

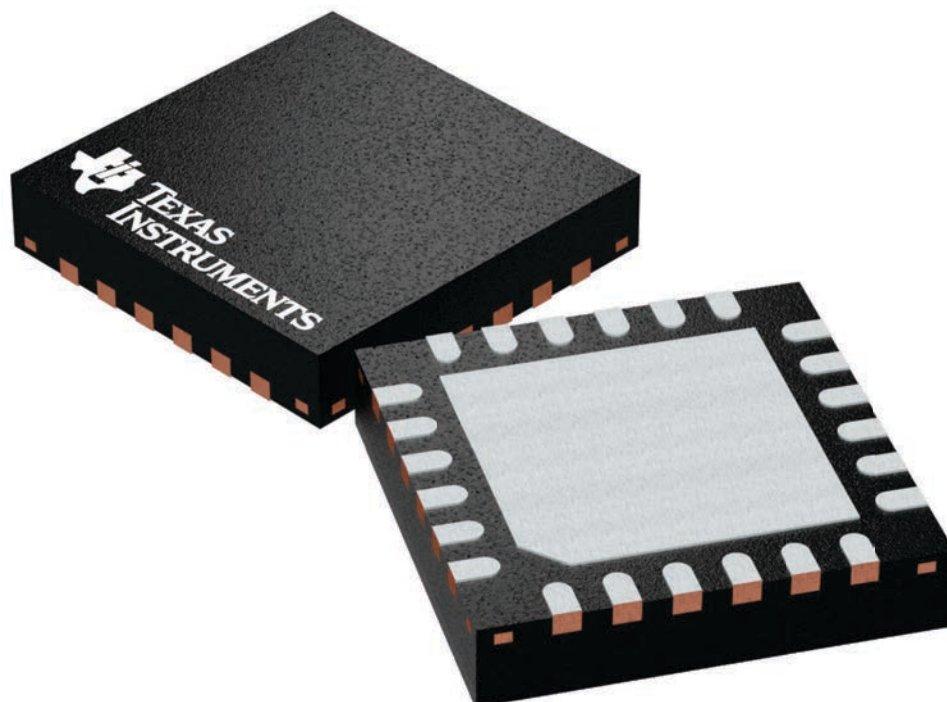

4224801/A

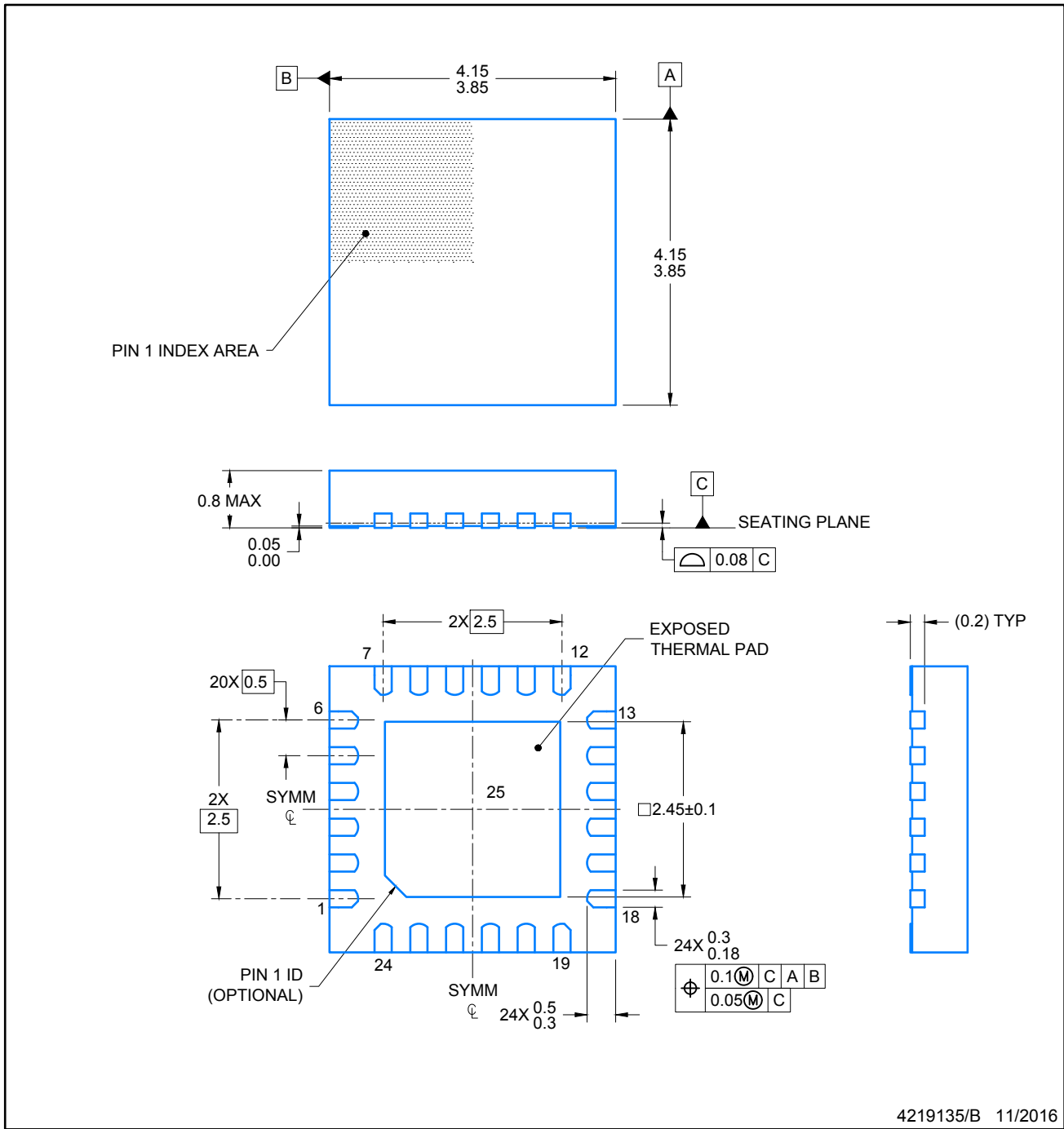

NOTES:

1. All linear dimensions are in millimeters. Any dimensions in parenthesis are for reference only. Dimensioning and tolerancing per ASME Y14.5M.
2. This drawing is subject to change without notice.

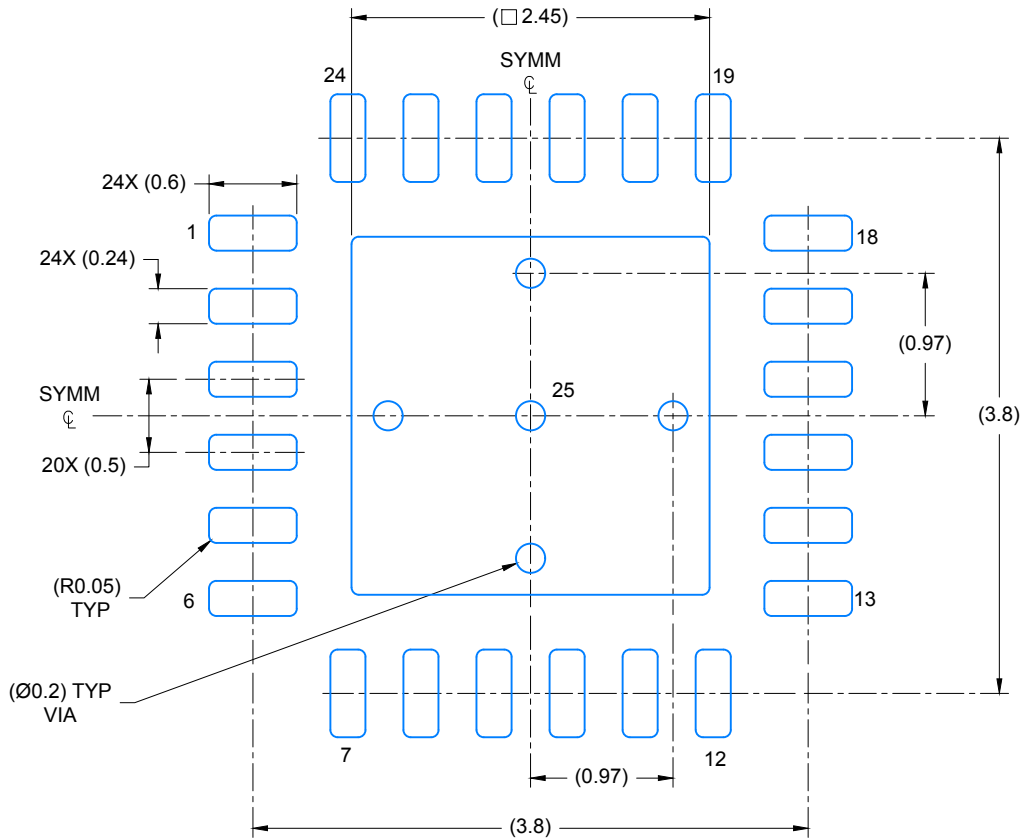

LAND PATTERN EXAMPLE
SCALE: 20X

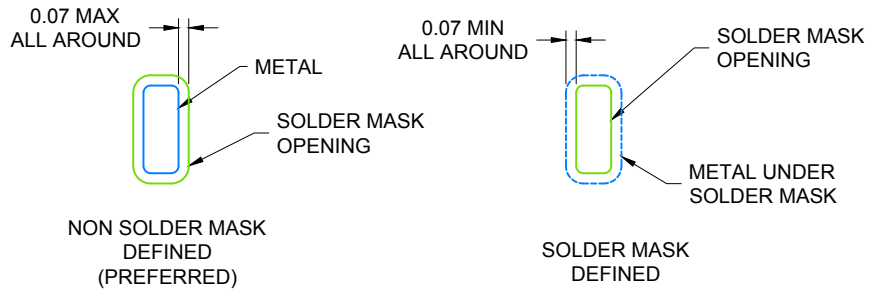

SOLDER MASK DETAILS

4219135/B 11/2016

NOTES: (continued)

- For more information, see Texas Instruments literature number SLUA271 (www.ti.com/lit/sluea271).

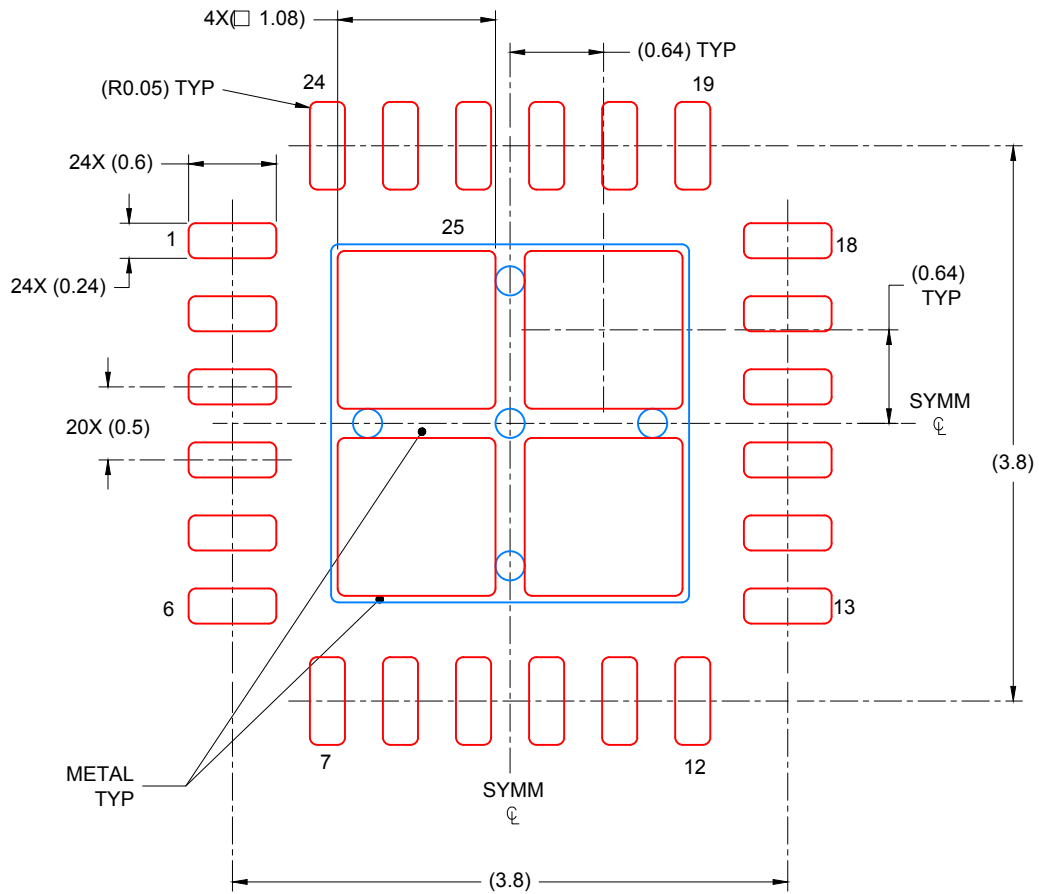

SOLDER PASTE EXAMPLE
 BASED ON 0.125 mm THICK STENCIL

EXPOSED PAD 25:
 78% PRINTED COVERAGE BY AREA UNDER PACKAGE
 SCALE: 20X

4219135/B 11/2016

NOTES: (continued)

4. Laser cutting apertures with trapezoidal walls and rounded corners may offer better paste release. IPC-7525 may have alternate design recommendations.

重要通知和免责声明

TI“按原样”提供技术和可靠性数据（包括数据表）、设计资源（包括参考设计）、应用或其他设计建议、网络工具、安全信息和其他资源，不保证没有瑕疵且不做任何明示或暗示的担保，包括但不限于对适销性、与某特定用途的适用性或不侵犯任何第三方知识产权的暗示担保。

这些资源可供使用 TI 产品进行设计的熟练开发人员使用。您将自行承担以下全部责任：(1) 针对您的应用选择合适的 TI 产品，(2) 设计、验证并测试您的应用，(3) 确保您的应用满足相应标准以及任何其他安全、安保法规或其他要求。

这些资源如有变更，恕不另行通知。TI 授权您仅可将这些资源用于研发本资源所述的 TI 产品的相关应用。严禁以其他方式对这些资源进行复制或展示。您无权使用任何其他 TI 知识产权或任何第三方知识产权。对于因您对这些资源的使用而对 TI 及其代表造成的任何索赔、损害、成本、损失和债务，您将全额赔偿，TI 对此概不负责。

TI 提供的产品受 [TI 销售条款](#)、[TI 通用质量指南](#) 或 [ti.com](#) 上其他适用条款或 TI 产品随附的其他适用条款的约束。TI 提供这些资源并不会扩展或以其他方式更改 TI 针对 TI 产品发布的适用的担保或担保免责声明。除非德州仪器 (TI) 明确将某产品指定为定制产品或客户特定产品，否则其产品均为按确定价格收入目录的标准通用器件。

TI 反对并拒绝您可能提出的任何其他或不同的条款。

版权所有 © 2026，德州仪器 (TI) 公司

最后更新日期：2025 年 10 月