

TCA9538 具有中断输出、复位和配置寄存器的低压 8 位 I²C 和 SMBus 低功耗 I/O 扩展器

1 特性

- 待机功耗低
- I²C 至并行端口扩展器
- 开漏电路低电平有效中断输出
- 低电平有效复位输入
- 1.65V 至 5.5V 的工作电源电压范围
- 可耐受 5V 电压的 I/O 端口
- 400kHz 快速 I²C 总线
- 两个硬件地址引脚可在 I²C/SMBus 上支持最多四个器件
- 输入和输出配置寄存器
- 极性反转寄存器
- 所用通道在加电时被配置为输入
- 加电时无毛刺脉冲
- SCL/SDA 输入端上的噪声滤波器
- 具有最大高电流驱动能力的锁存输出，适用于直接驱动 LED
- 锁断性能超过 100mA（符合 JESD 78 Class II 规范的要求）
- 静电放电 (ESD) 保护性能超过 JESD 22 规范要求
 - 2000V 人体模型 (A114-A)
 - 1000V 组件充电模式 (C101)

2 应用范围

- 服务器
- 路由器（电信交换设备）
- 个人计算机
- 个人电子产品（例如：游戏机）
- 工业自动化
- 采用 GPIO 受限处理器的产品

3 说明

TCA9538 是一款 16 引脚器件，可为两线双向 I²C 总线（或 SMBus）协议提供 8 位通用并行输入输出 (I/O) 扩展。该器件的工作电源电压范围是 1.65V 到 5.5V。器件支持 100kHz（标准模式）和 400kHz（快速模式）时钟频率。当开关、传感器、按钮、LED、风扇等设备需要额外的 I/O 时，I/O 扩展器（如 TCA9538）可提供简单解决方案。

当输入端口状态发生变化时，TCA9538 可在 $\overline{\text{INT}}$ 引脚上生成中断。硬件可选地址引脚 A0 和 A1 最多允许四个 TCA9538 器件位于同一 I²C 总线上。该器件还可通过 $\overline{\text{RESET}}$ 功能或电源循环供电生成加电复位，从而复位到默认状态。

器件信息(1)

器件型号	封装	封装尺寸（标称值）
TCA9538	TSSOP (16)	5.00mm x 4.40mm
	SSOP (16)	6.20mm x 5.30mm

(1) 如需了解所有可用封装，请见数据表末尾的可订购产品附录。

简化框图

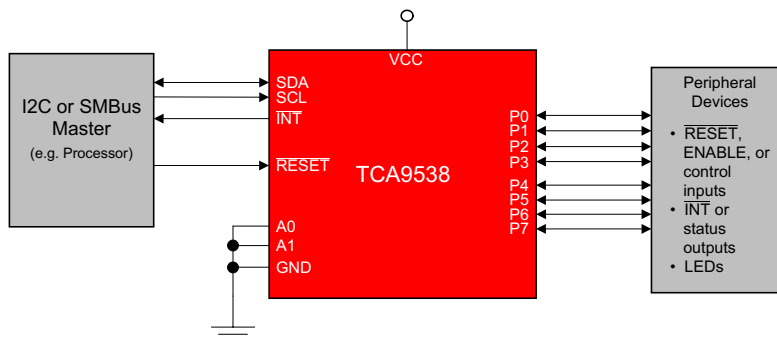

目录

1	特性	1	8.4	Device Functional Modes	17
2	应用范围	1	8.5	Programming	17
3	说明	1	8.6	Register Map	19
4	修订历史记录	2	9	Application and Implementation	23
5	Pin Configuration and Functions	3	9.1	Application Information	23
6	Specifications	4	9.2	Typical Application	23
6.1	Absolute Maximum Ratings	4	10	Power Supply Recommendations	26
6.2	ESD Ratings	4	10.1	Power-On Reset Requirements	26
6.3	Recommended Operating Conditions	4	11	Layout	28
6.4	Thermal Information	5	11.1	Layout Guidelines	28
6.5	Electrical Characteristics	5	11.2	Layout Example	28
6.6	I ² C Interface Timing Requirements	6	12	器件和文档支持	29
6.7	RESET Timing Requirements	7	12.1	文档支持	29
6.8	Switching Characteristics	7	12.2	接收文档更新通知	29
6.9	Typical Characteristics	8	12.3	社区资源	29
7	Parameter Measurement Information	10	12.4	商标	29
8	Detailed Description	14	12.5	静电放电警告	29
8.1	Overview	14	12.6	Glossary	29
8.2	Functional Block Diagram	15	13	机械、封装和可订购信息	29
8.3	Feature Description	16			

4 修订历史记录

注：之前版本的页码可能与当前版本有所不同。

Changes from Revision C (October 2015) to Revision D	Page
• Updated Figure 18	19

Changes from Revision B (September 2015) to Revision C	Page
• Added "Time to reset; V _{CC} = 1.65 V-2.3 V" parameter to RESET Timing Requirements table.	7
• Added "Output data valid; V _{CC} = 1.65 V-2.3 V" to Switching Characteristics table.	7
• Updated V _{CC_GW} parameter.	26

Changes from Revision A (September 2014) to Revision B	Page
• 已添加 DB 封装至数据表。	1

Changes from Original (August 2014) to Revision A	Page
• 已将文档更新为完整版。	1

5 Pin Configuration and Functions

**PW, DB Package
16-Pin TSSOP, SSOP
Top View**

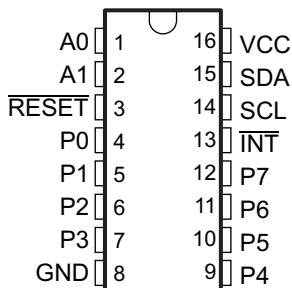

Pin Functions

PIN		I/O	DESCRIPTION
NAME	NO.		
A0	1	I	Address input. Connect directly to V_{CC} or ground
A1	2	I	Address input. Connect directly to V_{CC} or ground
GND	8	—	Ground
$\overline{\text{INT}}$	13	O	Interrupt output. Connect to V_{CC} through a pull-up resistor
P0	4	I/O	P-port input-output. Push-pull design structure. At power on, P0 is configured as an input
P1	5	I/O	P-port input-output. Push-pull design structure. At power on, P1 is configured as an input
P2	6	I/O	P-port input-output. Push-pull design structure. At power on, P2 is configured as an input
P3	7	I/O	P-port input-output. Push-pull design structure. At power on, P3 is configured as an input
P4	9	I/O	P-port input-output. Push-pull design structure. At power on, P4 is configured as an input
P5	10	I/O	P-port input-output. Push-pull design structure. At power on, P5 is configured as an input
P6	11	I/O	P-port input-output. Push-pull design structure. At power on, P6 is configured as an input
P7	12	I/O	P-port input-output. Push-pull design structure. At power on, P7 is configured as an input
$\overline{\text{RESET}}$	3	I	Active-low reset input. Connect to V_{CC} through a pull-up resistor if no active connection is used
SCL	14	I	Serial clock bus. Connect to V_{CC} through a pull-up resistor
SDA	15	I/O	Serial data bus. Connect to V_{CC} through a pull-up resistor
VCC	16	—	Supply voltage

6 Specifications

6.1 Absolute Maximum Ratings⁽¹⁾

over operating free-air temperature range (unless otherwise noted)

		MIN	MAX	UNIT
V _{CC}	Supply voltage	−0.5	6	V
V _I	Input voltage ⁽²⁾	−0.5	6	V
V _O	Output voltage ⁽²⁾	−0.5	6	V
I _{IK}	Input clamp current	V _I < 0	−20	mA
I _{OK}	Output clamp current	V _O < 0	−20	mA
I _{IOK}	Input-output clamp current	V _O < 0 or V _O > V _{CC}	±20	mA
I _{OL}	Continuous output low current through a single P-port	V _O = 0 to V _{CC}	50	mA
I _{OH}	Continuous output high current through a single P-port	V _O = 0 to V _{CC}	−50	mA
I _{CC}	Continuous current through GND by all P-ports, $\overline{\text{INT}}$, and SDA		250	mA
	Continuous current through V _{CC} by all P-ports		−160	
T _{stg}	Storage temperature	−65	150	°C

- (1) Stresses beyond those listed under *Absolute Maximum Ratings* may cause permanent damage to the device. These are stress ratings only, which do not imply functional operation of the device at these or any other conditions beyond those indicated under *Recommended Operating Conditions*. Exposure to absolute-maximum-rated conditions for extended periods may affect device reliability.
- (2) The input negative-voltage and output voltage ratings may be exceeded if the input and output current ratings are observed.

6.2 ESD Ratings

		VALUE	UNIT
V _(ESD)	Electrostatic discharge	Human-body model (HBM), per ANSI/ESDA/JEDEC JS-001 ⁽¹⁾	2000
		Charged-device model (CDM), per JEDEC specification JESD22-C101 ⁽²⁾	1000

- (1) JEDEC document JEP155 states that 500-V HBM allows safe manufacturing with a standard ESD control process. Manufacturing with less than 500-V HBM is possible with the necessary precautions.
- (2) JEDEC document JEP157 states that 250-V CDM allows safe manufacturing with a standard ESD control process. Manufacturing with less than 250-V CDM is possible with the necessary precautions.

6.3 Recommended Operating Conditions

		MIN	MAX	UNIT
V _{CC}	Supply voltage	1.65	5.5	V
V _{IH}	High-level input voltage	SCL, SDA	V _{CC} = 1.65 V to 5.5 V	0.7 × V _{CC}
		A0, A1, $\overline{\text{RESET}}$, P7–P0	V _{CC} = 1.65 V to 2.7 V	V _{CC} ⁽¹⁾
			V _{CC} = 3 V to 5.5 V	5.5
V _{IL}	Low-level input voltage	SCL, SDA	V _{CC} = 1.65 V to 5.5 V	0.3 × V _{CC}
		A0, A1, $\overline{\text{RESET}}$, P7–P0	V _{CC} = 1.65 V to 2.7 V	0.3 × V _{CC}
			V _{CC} = 3 V to 5.5 V	0.2 × V _{CC}
I _{OL}	Low-level output current	Any P-port, P7–P0	25	mA
I _{OH}	High-level output current	Any P-port, P7–P0	−10	mA
I _{CC}	Continuous current through GND	All P-ports P7–P0, $\overline{\text{INT}}$, and SDA	200	mA
	Continuous current through V _{CC}	All P-ports P7–P0	−80	
T _A	Operating free-air temperature	−40	85	°C

- (1) The SCL and SDA pins shall not be at a higher potential than the supply voltage V_{CC} in the application, or an increase in supply current, I_{CC}, will result.

6.4 Thermal Information

THERMAL METRIC ⁽¹⁾		TCA9538		UNIT
		PW (TSSOP)	DB (SSOP)	
		16 PINS	16 PINS	
R _{θJA}	Junction-to-ambient thermal resistance	122	113.2	°C/W
R _{θJC(top)}	Junction-to-case (top) thermal resistance	56.4	63.6	°C/W
R _{θJB}	Junction-to-board thermal resistance	67.1	64	°C/W
ψ _{JT}	Junction-to-top characterization parameter	10.8	21.2	°C/W
ψ _{JB}	Junction-to-board characterization parameter	66.5	63.4	°C/W

(1) For more information about traditional and new thermal metrics, see the [Semiconductor and IC Package Thermal Metrics](#) application report.

6.5 Electrical Characteristics

over operating free-air temperature range (unless otherwise noted)

PARAMETER		TEST CONDITIONS	V _{CC}	MIN	TYP ⁽¹⁾	MAX	UNIT
V _{IK}	Input diode clamp voltage	I _I = -18 mA	1.65 V to 5.5 V	-1.2			V
V _{PORR}	Power-on reset voltage, V _{CC} rising	V _I = V _{CC} or GND, I _O = 0			1.2	1.5	V
V _{PORF}	Power-on reset voltage, V _{CC} falling	V _I = V _{CC} or GND, I _O = 0		0.75	1		V
V _{OH}	P-port high-level output voltage ⁽²⁾	I _{OH} = -8 mA	1.65 V	1.2			V
			2.3 V	1.8			
			3 V	2.6			
			4.5 V	4.1			
		I _{OH} = -10 mA	1.65 V	1.1			
			2.3 V	1.7			
			3 V	2.5			
			4.5 V	4			
I _{OL}	SDA ⁽³⁾	V _{OL} = 0.4 V	1.65 V to 5.5 V	3	11		mA
	P port ⁽⁴⁾	V _{OL} = 0.5 V	1.65 V	8	10		
			2.3 V	8	13		
			3 V	8	15		
			4.5 V	8	17		
		V _{OL} = 0.7 V	1.65 V	10	14		
			2.3 V	10	17		
			3 V	10	20		
			4.5 V	10	24		
		$\overline{\text{INT}}$ ⁽⁵⁾	V _{OL} = 0.4 V	1.65 V to 5.5 V	3	7	
I _I	SCL, SDA	V _I = V _{CC} or GND	1.65 V to 5.5 V			±1	μA
	A0, A1, $\overline{\text{RESET}}$					±1	
I _{IH}	P port	V _I = V _{CC}	1.65 V to 5.5 V			1	μA
I _{IL}	P port	V _I = GND	1.65 V to 5.5 V			-1	μA

(1) All typical values are at nominal supply voltage (1.8-, 2.5-, 3.3-, or 5-V V_{CC}) and T_A = 25°C.

(2) Each P-port I/O configured as a high output must be externally limited to a maximum of 10 mA, and the total current sourced by all I/Os (P-ports P7-P0) through V_{CC} must be limited to a maximum current of 80 mA.

(3) The SDA pin must be externally limited to a maximum of 12 mA, and the total current sunk by all I/Os (P-ports P7-P0, $\overline{\text{INT}}$, and SDA) through GND must be limited to a maximum current of 200 mA.

(4) Each P-port I/O configured as a low output must be externally limited to a maximum of 25 mA, and the total current sunk by all I/Os (P-ports P7-P0, $\overline{\text{INT}}$, and SDA) through GND must be limited to a maximum current of 200 mA.

(5) The $\overline{\text{INT}}$ pin must be externally limited to a maximum of 7 mA, and the total current sunk by all I/Os (P-ports P7-P0, $\overline{\text{INT}}$, and SDA) through GND must be limited to a maximum current of 200 mA.

Electrical Characteristics (continued)

over operating free-air temperature range (unless otherwise noted)

PARAMETER		TEST CONDITIONS	V _{CC}	MIN	TYP ⁽¹⁾	MAX	UNIT
I _{CC}	Operating mode	V _I = V _{CC} or GND, I _O = 0, I/O = inputs, f _{scl} = 400 kHz, No load t _r = 3 ns	5.5 V		18	30	μA
			5.5 V		34		
			3.6 V		15		
			2.7 V		9		
			1.65 V		5		
			5.5 V		20		
			V _I = V _{CC} or GND, I _O = 0, I/O = inputs, f _{scl} = 100 kHz, No load t _{r,max} = 1 μs	3.6 V		8	
			2.7 V		5		
			1.65 V		3		
	Standby mode	V _I = V _{CC} or GND, I _O = 0, I/O = inputs, f _{scl} = 0 kHz, No load	5.5 V		1.9	3.5	μA
3.6 V				1.1	1.8		
2.7 V				1	1.6		
1.65 V				0.4	1		
ΔI _{CC}	Additional current in standby mode	One P-port input at V _{CC} – 0.6 V, Other P-port inputs at V _{CC} or GND	1.65 V to 5.5 V			70	μA
C _i	SCL	V _I = V _{CC} or GND	1.65 V to 5.5 V		4	5	pF
C _{iO}	SDA	V _{IO} = V _{CC} or GND	1.65 V to 5.5 V		5.5	6.5	pF
	P port				8	9.5	

6.6 I²C Interface Timing Requirements

over operating free-air temperature range (unless otherwise noted) (see Figure 9)

		MIN	MAX	UNIT
STANDARD MODE				
f _{scl}	I ² C clock frequency	0	100	kHz
t _{sch}	I ² C clock high time	4		μs
t _{scl}	I ² C clock low time	4.7		μs
t _{sp}	I ² C spike time		50	ns
t _{sds}	I ² C serial-data setup time	250		ns
t _{sdh}	I ² C serial-data hold time	0		ns
t _{icr}	I ² C input rise time		1000	ns
t _{icf}	I ² C input fall time		300	ns
t _{ocf}	I ² C output fall time	10-pF to 400-pF bus	300	ns
t _{buf}	I ² C bus free time between Stop and Start	4.7		μs
t _{sts}	I ² C Start or repeated Start condition setup	4.7		μs
t _{sth}	I ² C Start or repeated Start condition hold	4		μs
t _{sps}	I ² C Stop condition setup	4		μs
t _{vd(data)}	Valid data time	SCL low to SDA output valid	3.45	μs
t _{vd(ack)}	Valid data time of ACK condition	ACK signal from SCL low to SDA (out) low	3.45	μs
C _b	I ² C bus capacitive load		400	ns
FAST MODE				
f _{scl}	I ² C clock frequency	0	400	kHz
t _{sch}	I ² C clock high time	0.6		μs
t _{scl}	I ² C clock low time	1.3		μs
t _{sp}	I ² C spike time		50	ns
t _{sds}	I ² C serial-data setup time	100		ns

I²C Interface Timing Requirements (continued)

over operating free-air temperature range (unless otherwise noted) (see [Figure 9](#))

		MIN	MAX	UNIT
t _{sdh}	I ² C serial-data hold time	0		ns
t _{icr}	I ² C input rise time	20	300	ns
t _{icf}	I ² C input fall time	20 × (V _{DD} / 5.5 V)	300	ns
t _{ocf}	I ² C output fall time	10-pF to 400-pF bus	20 × (V _{DD} / 5.5 V)	300
t _{buf}	I ² C bus free time between Stop and Start	1.3		μs
t _{sts}	I ² C Start or repeated Start condition setup	0.6		μs
t _{sth}	I ² C Start or repeated Start condition hold	0.6		μs
t _{sps}	I ² C Stop condition setup	0.6		μs
t _{vd(data)}	Valid data time	SCL low to SDA output valid	0.9	μs
t _{vd(ack)}	Valid data time of ACK condition	ACK signal from SCL low to SDA (out) low	0.9	μs
C _b	I ² C bus capacitive load		400	ns

6.7 RESET Timing Requirements

over operating free-air temperature range (unless otherwise noted)

PARAMETER		MIN	MAX	UNIT
STANDARD and FAST MODE				
t _w	Reset pulse duration	4		ns
t _{REC}	Reset recovery time	0		ns
t _{RESET}	Time to reset; V _{CC} = 2.3 V-5.5 V	400		ns
	Time to reset; V _{CC} = 1.65 V-2.3 V	550		

6.8 Switching Characteristics

over operating free-air temperature range (unless otherwise noted) (see [Figure 10](#) and [Figure 11](#))

PARAMETER		FROM (INPUT)	TO (OUTPUT)	MIN	MAX	UNIT
STANDARD and FAST MODE						
t _{iv}	Interrupt valid time	P port	$\overline{\text{INT}}$		4	μs
t _{ir}	Interrupt reset delay time	SCL	$\overline{\text{INT}}$		4	μs
t _{pv}	Output data valid; V _{CC} = 2.3 V-5.5 V	SCL	P7-P0		200	ns
	Output data valid; V _{CC} = 1.65 V-2.3 V				300	
t _{ps}	Input data setup time	P port	SCL	100		ns
t _{ph}	Input data hold time	P port	SCL	1		μs

6.9 Typical Characteristics

T_A = 25°C (unless otherwise noted)

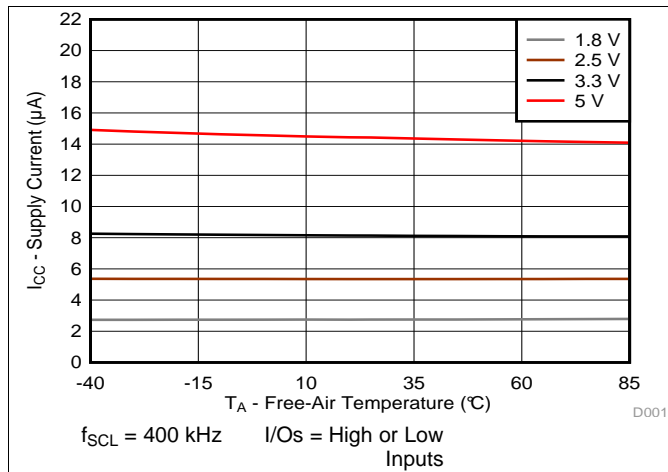

Figure 1. Supply Current (I_{CC}, Operating Mode) vs Temperature (T_A) at Four Supply Voltages

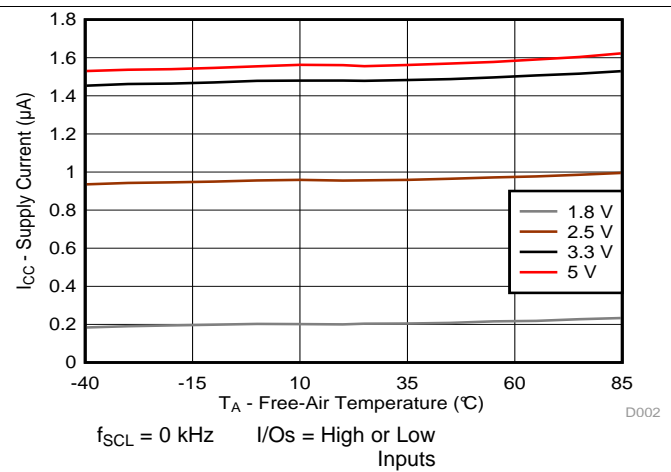

Figure 2. Supply Current (I_{CC}, Standby Mode) vs Temperature (T_A) at Four Supply Voltages

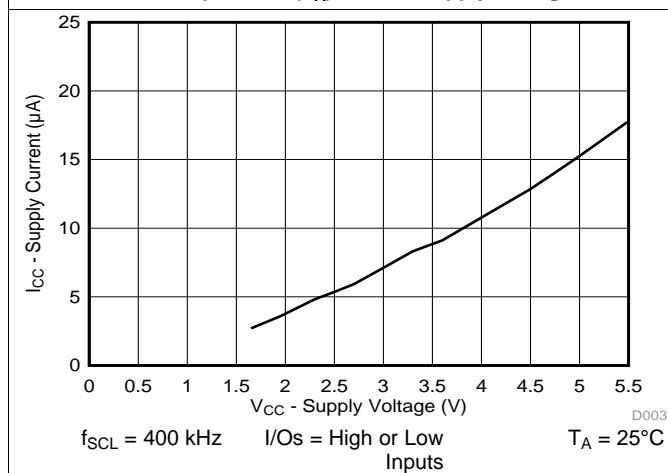

Figure 3. Supply Current (I_{CC}, Operating Mode) vs Supply Voltage (V_{CC})

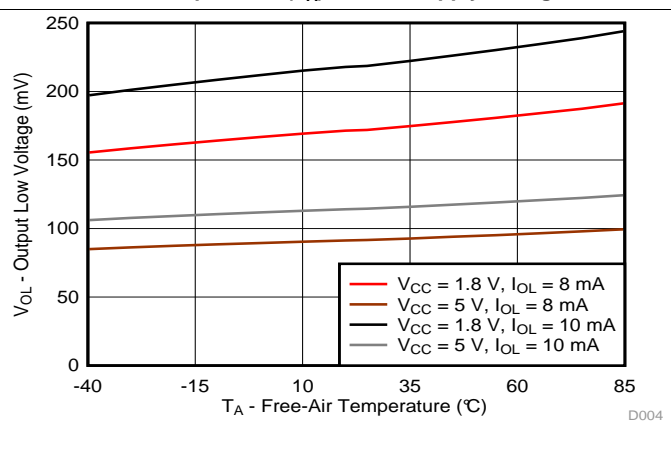

Figure 4. Output Low Voltage (V_{OL}) vs Temperature (T_A) for P-Port I/Os

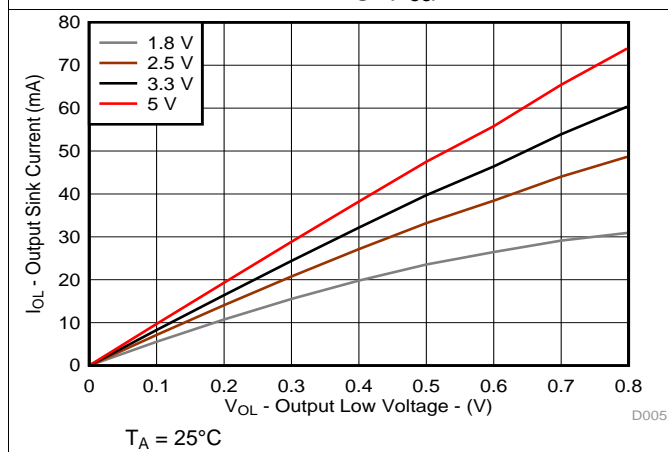

Figure 5. Sink Current (I_{OL}) vs Output Low Voltage (V_{OL}) for P-Ports at Four Supply Voltages

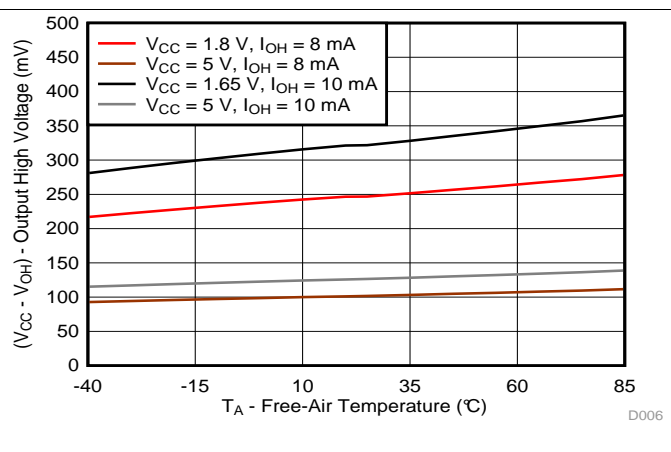
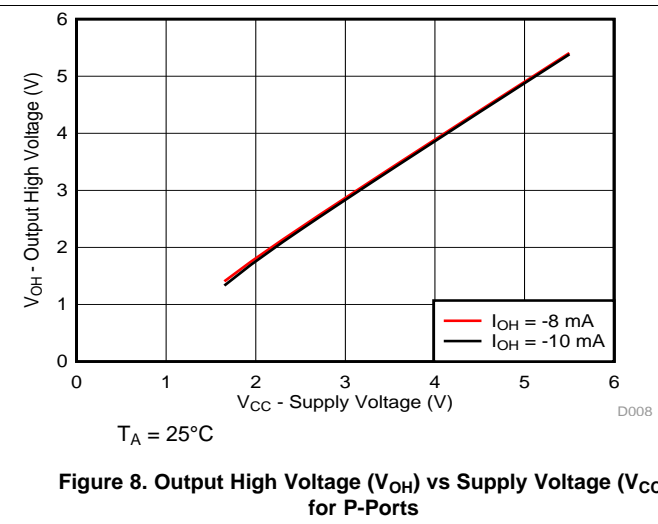
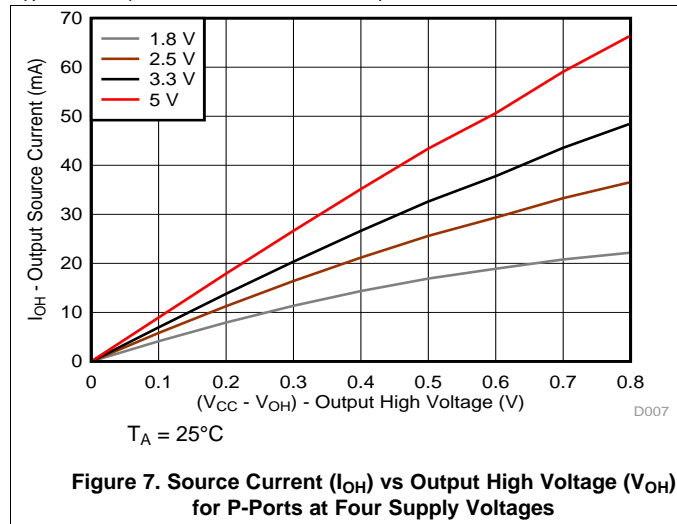

Figure 6. Output High Voltage (V_{CC} - V_{OH}) vs Temperature (T_A) for P-Ports

Typical Characteristics (continued)

T_A = 25°C (unless otherwise noted)



7 Parameter Measurement Information

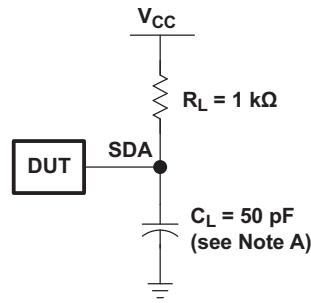

SDA LOAD CONFIGURATION

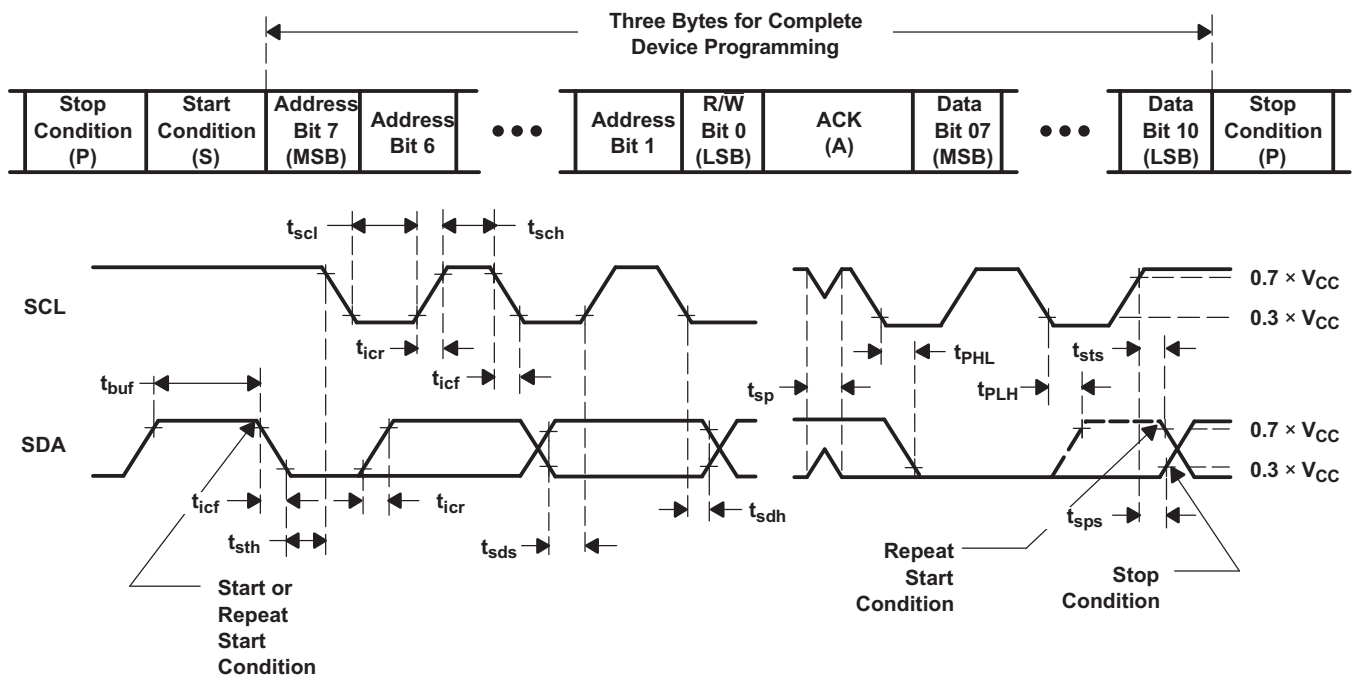

VOLTAGE WAVEFORMS

BYTE	DESCRIPTION
1	I ² C address
2, 3	P-port data

- A. C_L includes probe and jig capacitance.
- B. All inputs are supplied by generators having the following characteristics: $PRR \leq 10$ MHz, $Z_O = 50 \Omega$, $t_r/t_f \leq 30$ ns.
- C. All parameters and waveforms are not applicable to all devices.

Figure 9. I²C Interface Load Circuit and Voltage Waveforms

Parameter Measurement Information (continued)

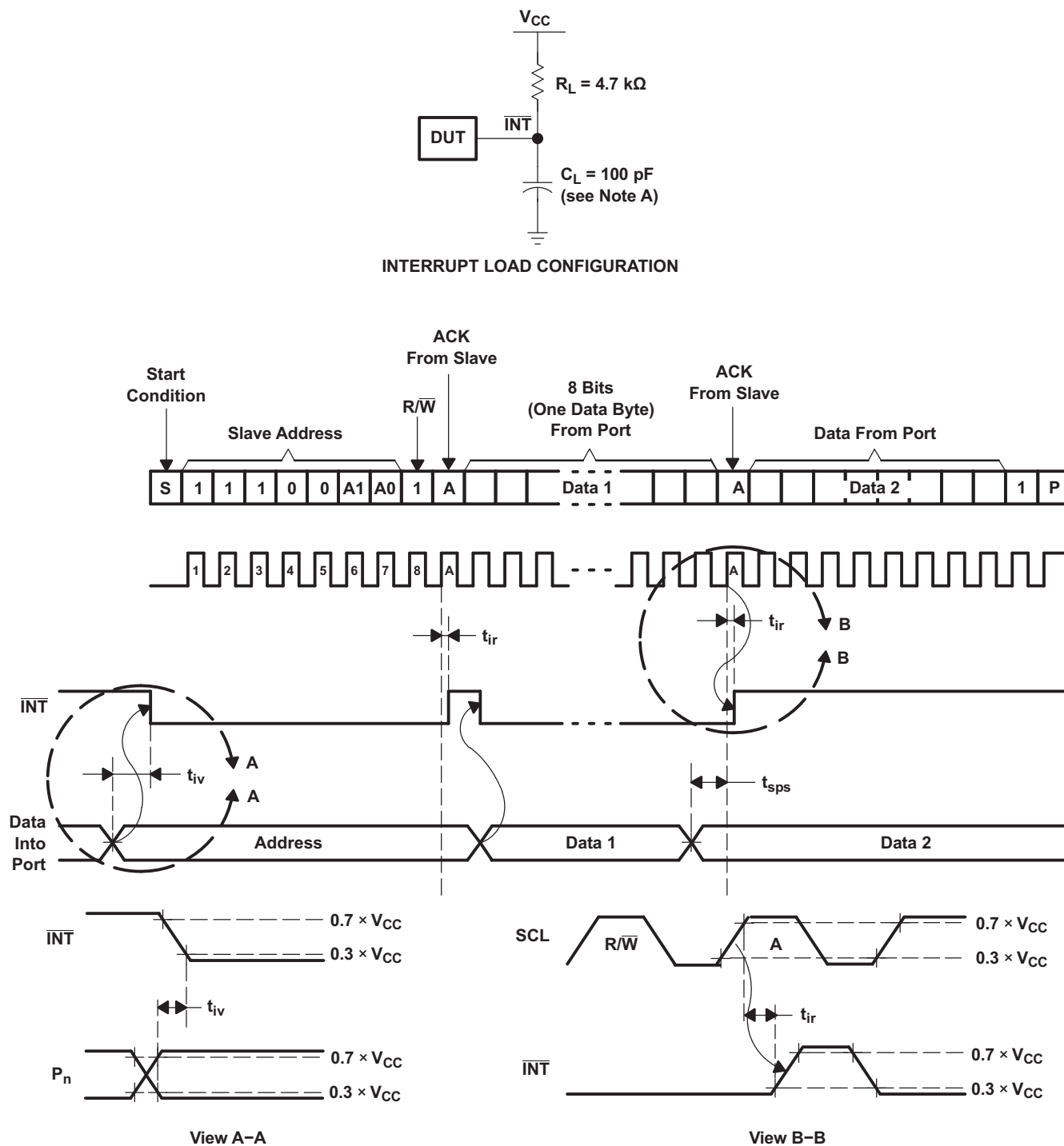

- A. C_L includes probe and jig capacitance.
- B. All inputs are supplied by generators having the following characteristics: PRR ≤ 10 MHz, Z_O = 50 Ω, t_r/t_f ≤ 30 ns.
- C. All parameters and waveforms are not applicable to all devices.

Figure 10. Interrupt Load Circuit and Voltage Waveforms

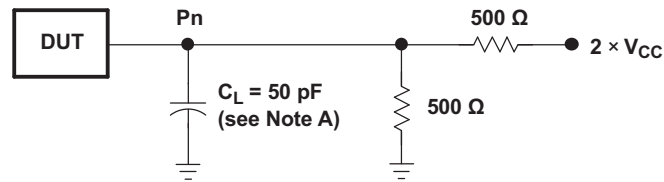
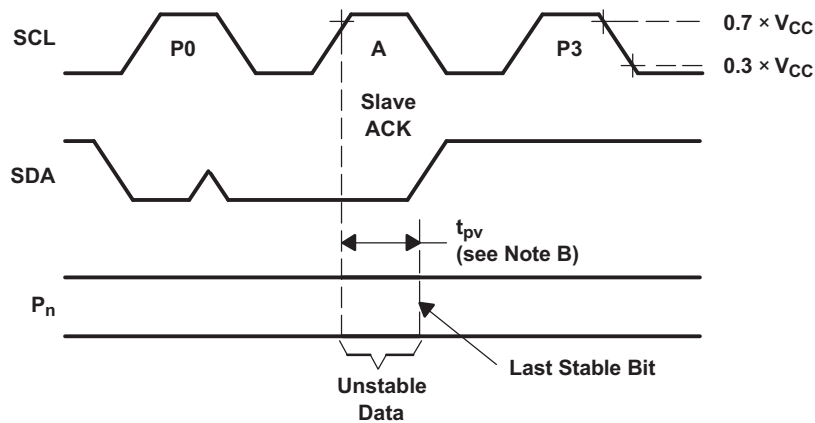
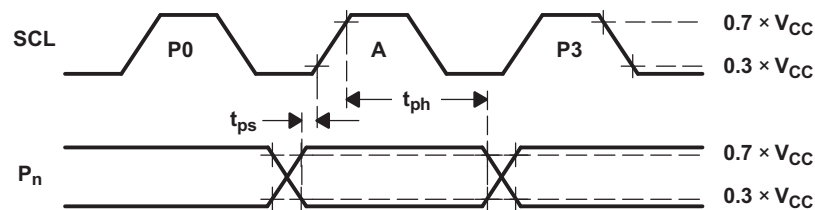
Parameter Measurement Information (continued)

P-PORT LOAD CONFIGURATION

WRITE MODE ($R/\bar{W} = 0$)

READ MODE ($R/\bar{W} = 1$)

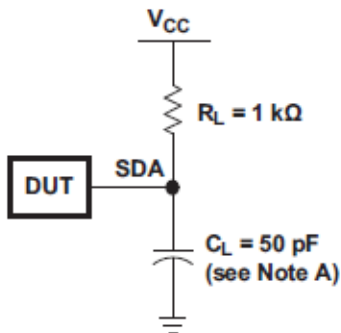
- A. C_L includes probe and jig capacitance.
- B. All inputs are supplied by generators having the following characteristics: $PRR \leq 10$ MHz, $Z_O = 50 \Omega$, $t_r/t_f \leq 30$ ns.
- C. The outputs are measured one at a time, with one transition per measurement.
- D. All parameters and waveforms are not applicable to all devices.

Figure 11. P-Port Load Circuit and Voltage Waveforms

Parameter Measurement Information (continued)



SDA LOAD CONFIGURATION

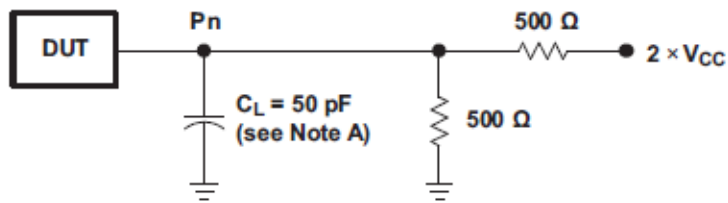

P-PORT LOAD CONFIGURATION

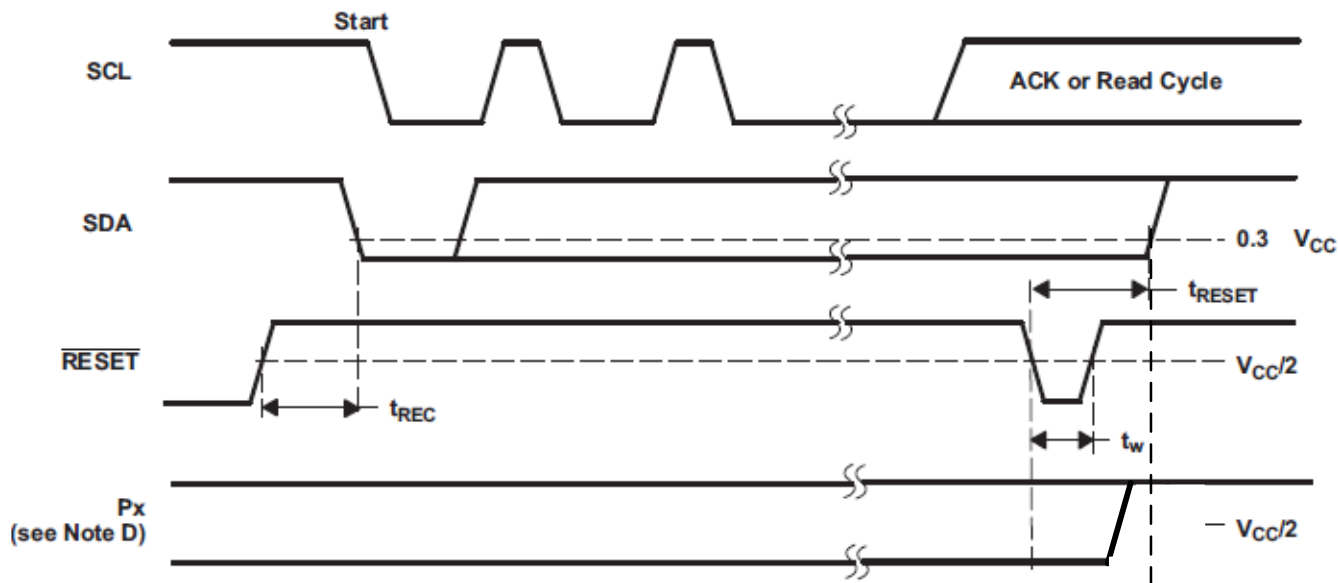

- A. C_L includes probe and jig capacitance.
- B. All inputs are supplied by generators having the following characteristics: $PRR \leq 10\text{ MHz}$, $Z_O = 50\ \Omega$, $t_r/t_f \leq 30\text{ ns}$.
- C. The outputs are measured one at a time, with one transition per measurement.
- D. I/Os are configured as inputs.
- E. All parameters and waveforms are not applicable to all devices.

Figure 12. Reset Load Circuits and Voltage Waveforms

8 Detailed Description

8.1 Overview

The TCA9538 is an 8-bit I/O expander for the two-line bidirectional bus (I²C) is designed for 1.65-V to 5.5-V V_{CC} operation. It provides general-purpose remote I/O expansion for most micro-controller families via the I²C interface (serial clock, SCL, and serial data, SDA, pins).

The TCA9538 open-drain interrupt ($\overline{\text{INT}}$) output is activated when any input state differs from its corresponding Input Port register state and is used to indicate to the system master that an input state has changed. The INT pin can be connected to the interrupt input of a micro-controller. By sending an interrupt signal on this line, the remote I/O can inform the micro-controller if there is incoming data on its ports without having to communicate via the I²C bus. Thus, the TCA9538 can remain a simple slave device. The device outputs (latched) have high-current drive capability for directly driving LEDs.

Two hardware pins (A0 and A1) are used to program and vary the fixed I²C slave address and allow up to four devices to share the same I²C bus or SMBus.

The system master can reset the TCA9538 in the event of a timeout or other improper operation by asserting a low on the $\overline{\text{RESET}}$ input pin or by cycling the power supply and causing a power-on reset (POR). A reset puts the registers in their default state and initializes the I²C /SMBus state machine. The $\overline{\text{RESET}}$ feature and a POR cause the same reset/initialization to occur, but the $\overline{\text{RESET}}$ feature does so without powering down the part.

The TCA9538 consists of one 8-bit Configuration (input or output selection), Input Port, Output Port, and Polarity Inversion (active high or active low) registers. At power on, the I/Os are configured as inputs. However, the system master can enable the I/Os as either inputs or outputs by writing to the I/O configuration bits. The data for each input or output is kept in the corresponding Input Port or Output Port register. The polarity of the Input Port register can be inverted with the Polarity Inversion register. All registers can be read by the system master.

The TCA9538 is identical to the TCA9554 except for the removal of the internal I/O pull-up resistors, which greatly reduces power consumption when the I/Os are held LOW, the replacement of A2 with $\overline{\text{RESET}}$, and different slave address range.

8.2 Functional Block Diagram

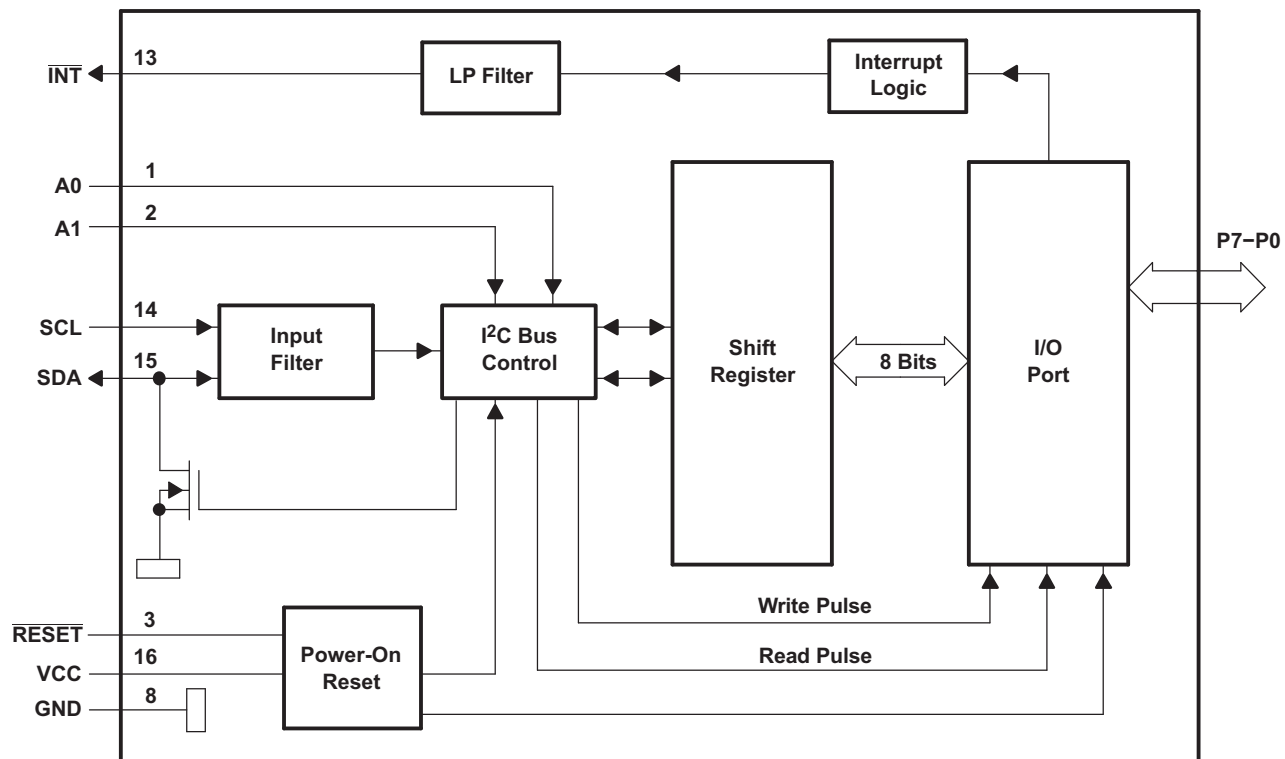

Pin numbers shown are for the PW package.

Figure 13. Functional Block Diagram

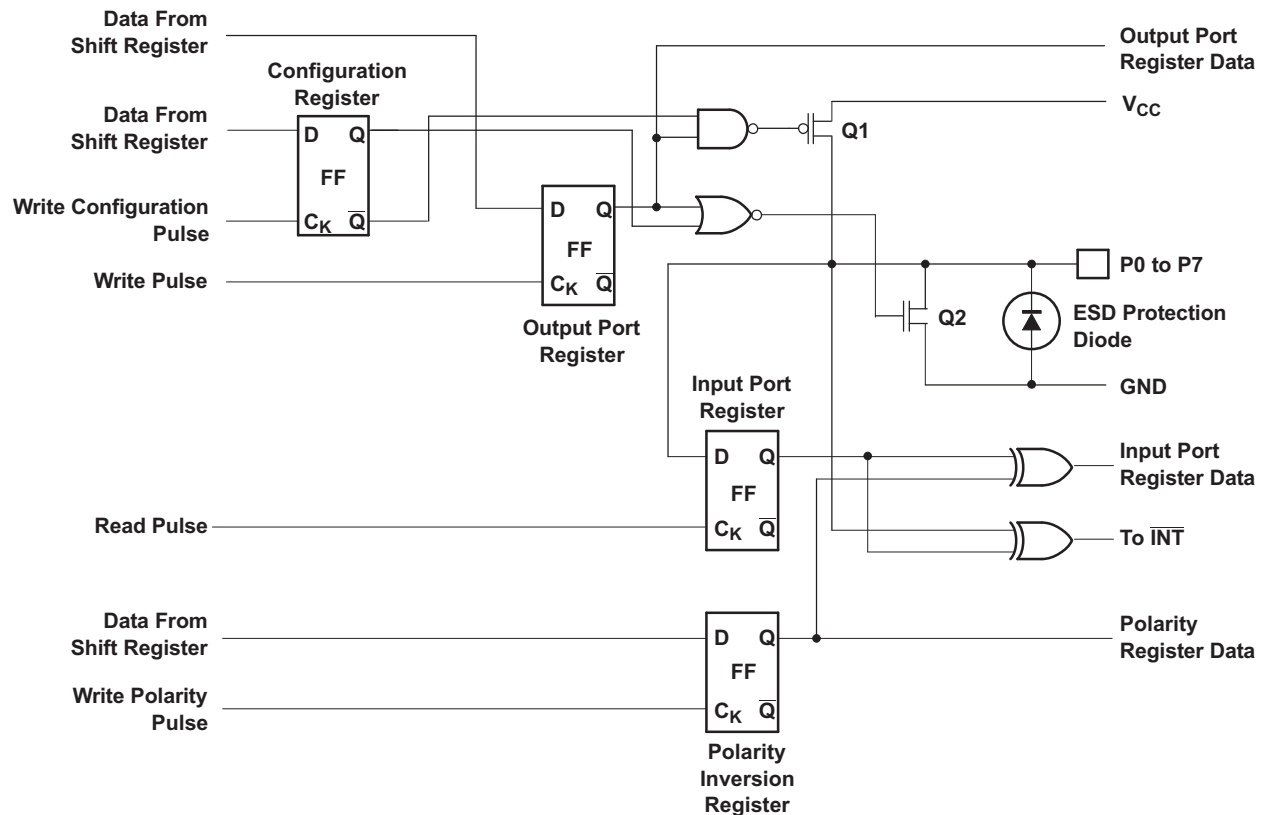
Functional Block Diagram (continued)

At power-on reset, all registers return to default values.

Figure 14. Simplified Schematic of P0 to P7

8.3 Feature Description

8.3.1 I/O Port

When an I/O is configured as an input, FETs Q1 and Q2 are off, creating a high-impedance input. The input voltage may be raised above V_{CC} to a maximum of 5.5 V.

If the I/O is configured as an output, Q1 or Q2 is enabled depending on the state of the output port register. In this case, there are low impedance paths between the I/O pin and either V_{CC} or GND. The external voltage applied to this I/O pin must not exceed the recommended levels for proper operation.

8.3.2 Interrupt Output (\bar{INT})

An interrupt is generated by any rising or falling edge of any P-port I/O configured as an input. After time t_{iv} , the signal \bar{INT} is valid. Resetting the interrupt circuit is achieved when data on the ports is changed back to the original state or when data is read from the Input Port register. Resetting occurs in the read mode at the acknowledge (ACK) bit after the rising edge of the SCL signal. Interrupts that occur during the ACK clock pulse can be lost (or be very short) due to the resetting of the interrupt during this pulse. Each change of the I/Os after resetting is detected and is transmitted as an interrupt on the \bar{INT} pin.

Reading from or writing to another device does not affect the interrupt circuit, and a pin configured as an output cannot cause an interrupt. Changing an I/O from an output to an input may cause a false interrupt to occur if the state of the pin does not match the contents of the Input Port register.

The \bar{INT} output has an open-drain structure and requires pull-up resistor to V_{CC} .

Feature Description (continued)

8.3.3 RESET Input

The $\overline{\text{RESET}}$ input can be asserted to reset the system while keeping the V_{CC} at its operating level. A reset can be accomplished by holding the $\overline{\text{RESET}}$ pin low for a minimum of t_{W} . The TCA9538 registers and I²C/SMBus state machine are changed to their default states once $\overline{\text{RESET}}$ is low (0). Once $\overline{\text{RESET}}$ is high (1), the I/O levels at the P port can be changed externally or through the master. This input requires a pull-up resistor to V_{CC} if no active connection is used.

8.4 Device Functional Modes

8.4.1 Power-On Reset

When power (from 0 V) is applied to V_{CC} , an internal power-on reset holds the TCA9538 in a reset condition until V_{CC} has reached V_{PORR} . At that point, the reset condition is released and the TCA9538 registers and SMBus/I²C state machine initialize to their default states. After that, V_{CC} must be lowered to below V_{PORF} and then back up to the operating voltage for a power-on reset cycle.

8.5 Programming

8.5.1 I²C Interface

The bidirectional I²C bus consists of the serial clock (SCL) and serial data (SDA) lines. Both lines must be connected to a positive supply through a pull-up resistor when connected to the output stages of a device. Data transfer may be initiated only when the bus is not busy.

I²C communication with this device is initiated by a master sending a Start condition, a high-to-low transition on the SDA input/output while the SCL input is high (see Figure 15). After the Start condition, the device address byte is sent, most significant bit (MSB) first, including the data direction bit (R/W).

After receiving the valid address byte, this device responds with an acknowledge (ACK), a low on the SDA input/output during the high of the ACK-related clock pulse. The address inputs (A0–A1) of the slave device must not be changed between the Start and the Stop conditions.

On the I²C bus, only one data bit is transferred during each clock pulse. The data on the SDA line must remain stable during the high pulse of the clock period, as changes in the data line at this time are interpreted as control commands (Start or Stop) (see Figure 16).

A Stop condition, a low-to-high transition on the SDA input/output while the SCL input is high, is sent by the master (see Figure 15).

Any number of data bytes can be transferred from the transmitter to receiver between the Start and the Stop conditions. Each byte of eight bits is followed by one ACK bit. The transmitter must release the SDA line before the receiver can send an ACK bit. The device that acknowledges must pull down the SDA line during the ACK clock pulse so that the SDA line is stable low during the high pulse of the ACK-related clock period (see Figure 17). When a slave receiver is addressed, it must generate an ACK after each byte is received. Similarly, the master must generate an ACK after each byte that it receives from the slave transmitter. Setup and hold times must be met to ensure proper operation.

A master receiver signals an end of data to the slave transmitter by not generating an acknowledge (NACK) after the last byte has been clocked out of the slave. This is done by the master receiver by holding the SDA line high. In this event, the transmitter must release the data line to enable the master to generate a Stop condition.

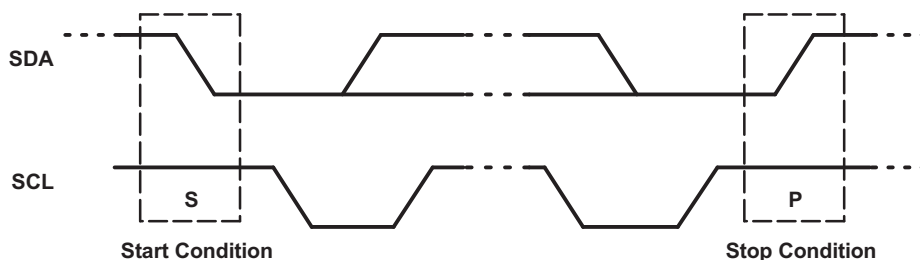

Figure 15. Definition of Start and Stop Conditions

Programming (continued)

Figure 16. Bit Transfer

Figure 17. Acknowledgment on I²C Bus

Table 1 shows the TCA9538 interface definition.

Table 1. Interface Definition Table

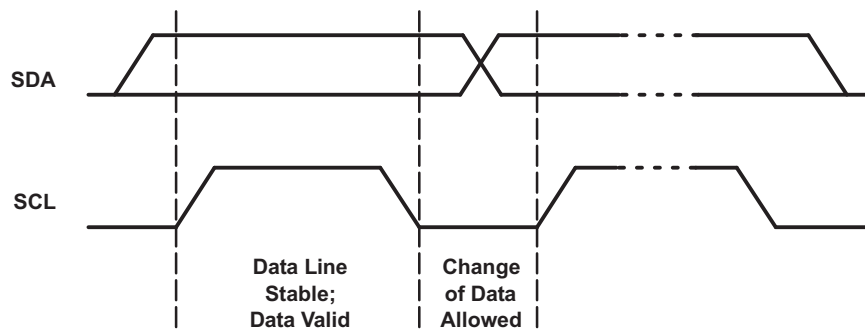
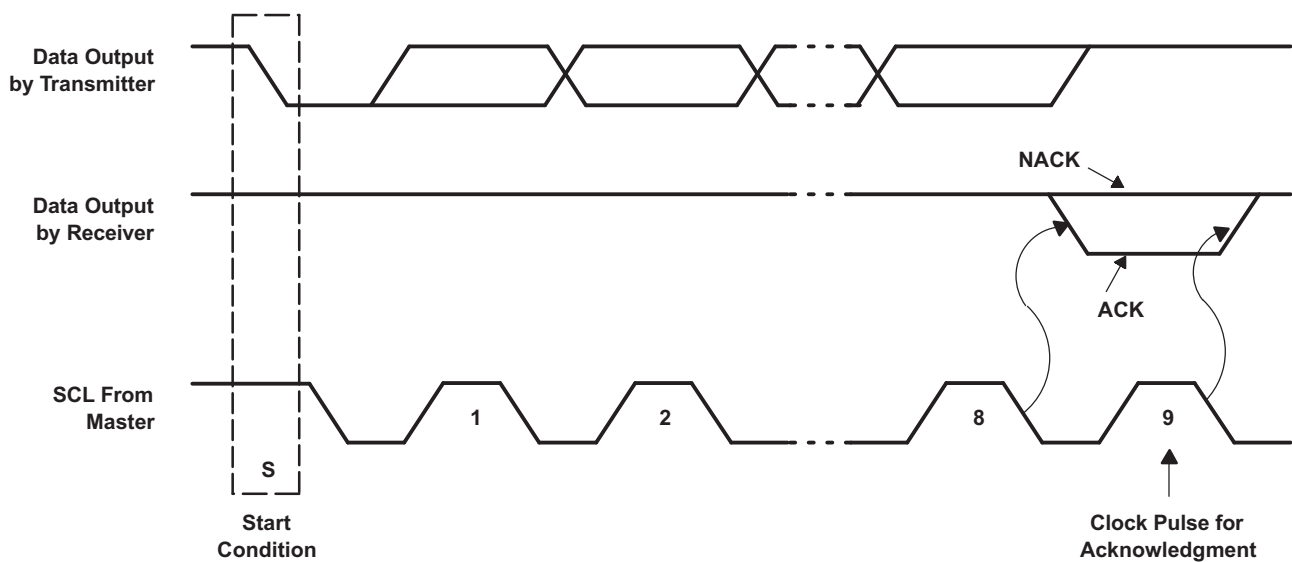
BYTE	BIT							
	7 (MSB)	6	5	4	3	2	1	0 (LSB)
I ² C slave address	H	H	H	L	L	A1	A0	R/ \bar{W}
Px I/O data bus	P7	P6	P5	P4	P3	P2	P1	P0

8.6 Register Map

8.6.1 Device Address

Figure 18 shows the address byte of the TCA9538.

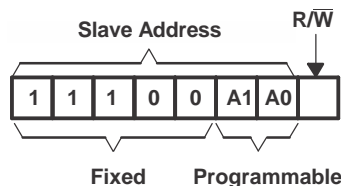

Figure 18. TCA9538 Address

Table 2 shows the Address Reference of the TCA9538.

Table 2. Address Reference Table

INPUTS		I ² C BUS SLAVE ADDRESS
A1	A0	
L	L	112 (decimal), 70 (hexadecimal)
L	H	113 (decimal), 71 (hexadecimal)
H	L	114 (decimal), 72 (hexadecimal)
H	H	115 (decimal), 73 (hexadecimal)

The last bit of the slave address defines the operation (read or write) to be performed. When it is high (1), a read is selected while a low (0) selects a write operation.

8.6.2 Control Register and Command Byte

Following the successful Acknowledgment of the address byte, the bus master sends a command byte that is stored in the control register in the TCA9538 (see Figure 19). Two bits of this command byte state the operation (read or write) and the internal register (input, output, polarity inversion or configuration) that is affected. This register can be written or read through the I²C bus. The command byte is sent only during a write transmission.

Once a command byte has been sent, the register that was addressed continues to be accessed by reads until a new command byte has been sent.

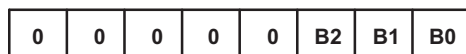

Figure 19. Control Register Bits

Table 3 shows the TCA9538 Command byte.

Table 3. Command Byte Table

CONTROL REGISTER BITS		COMMAND BYTE (HEX)	REGISTER	PROTOCOL	POWER-UP DEFAULT
B1	B0				
0	0	0x00	Input Port	Read byte	XXXX XXXX
0	1	0x01	Output Port	Read/write byte	1111 1111
1	0	0x02	Polarity Inversion	Read/write byte	0000 0000
1	1	0x03	Configuration	Read/write byte	1111 1111

8.6.3 Register Descriptions

The Input Port register (register 0) reflects the incoming logic levels of the pins, regardless of whether the pin is defined as an input or an output by the Configuration register. It only acts on read operation. Writes to these registers have no effect. The default value, X, is determined by the externally applied logic level.

Before a read operation, a write transmission is sent with the command byte to indicate to the I²C device that the Input Port register is accessed next. See [Table 4](#).

Table 4. Register 0 (Input Port Register) Table

BIT	I7	I6	I5	I4	I3	I2	I1	I0
DEFAULT	X	X	X	X	X	X	X	X

The Output Port register (register 1) shows the outgoing logic levels of the pins defined as outputs by the Configuration register. Bit values in this register have no effect on pins defined as inputs. In turn, reads from this register reflect the value that is in the flip-flop controlling the output selection, not the actual pin value. See [Table 5](#).

Table 5. Register 1 (Output Port Register) Table

BIT	O7	O6	O5	O4	O3	O2	O1	O0
DEFAULT	1	1	1	1	1	1	1	1

The Polarity Inversion register (register 2) allows polarity inversion of pins defined as inputs by the Configuration register. If a bit in this register is set (written with 1), the corresponding port pin polarity is inverted. If a bit in this register is cleared (written with a 0), the corresponding port pin original polarity is retained. See [Table 6](#).

Table 6. Register 2 (Polarity Inversion Register) Table

BIT	N7	N6	N5	N4	N3	N2	N1	N0
DEFAULT	0	0	0	0	0	0	0	0

The Configuration register (register 3) configures the directions of the I/O pins. If a bit in this register is set to 1, the corresponding port pin is enabled as an input with a high-impedance output driver. If a bit in this register is cleared to 0, the corresponding port pin is enabled as an output. See [Table 7](#).

Table 7. Register 3 (Configuration Register) Table

BIT	C7	C6	C5	C4	C3	C2	C1	C0
DEFAULT	1	1	1	1	1	1	1	1

8.6.3.1 Bus Transactions

Data is exchanged between the master and the TCA9538 through write and read commands.

8.6.3.1.1 Writes

Data is transmitted to the TCA9538 by sending the device address and setting the least-significant bit (LSB) to a logic 0 (see Figure 18 for device address). The command byte is sent after the address and determines which register receives the data that follows the command byte (see Figure 20 and Figure 21). There is no limitation on the number of data bytes sent in one write transmission.

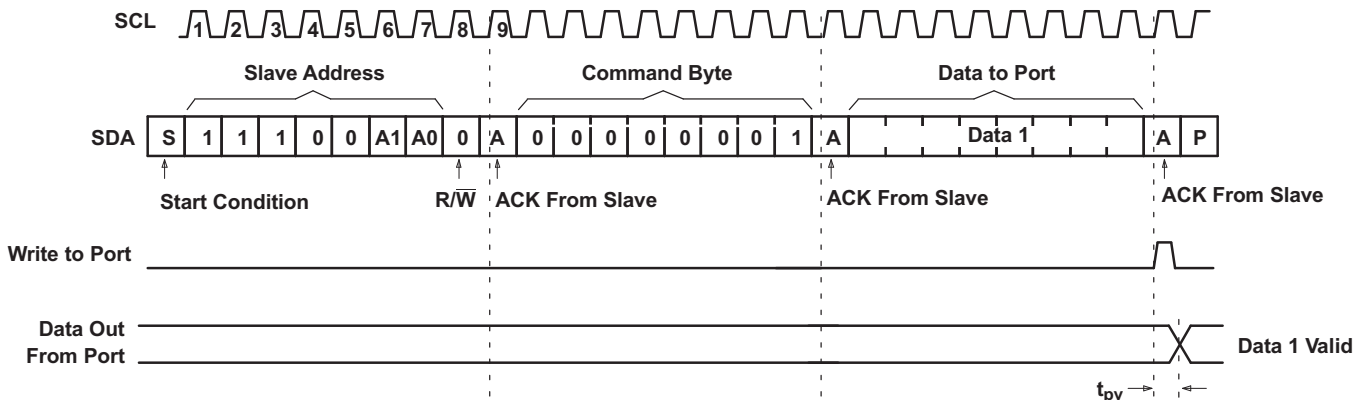

Figure 20. Write to Output Port Register

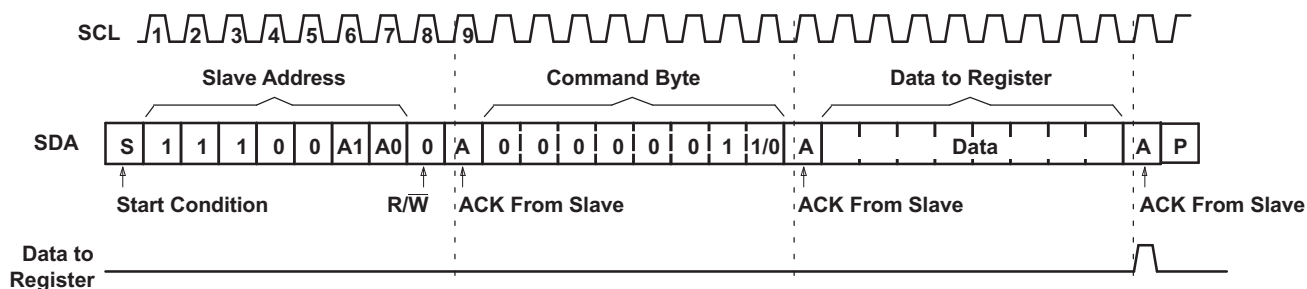
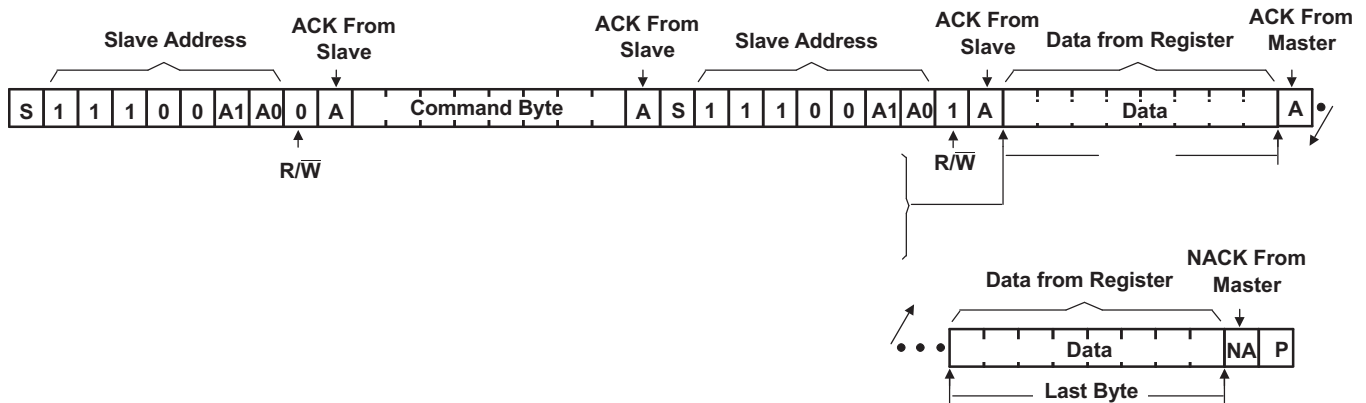
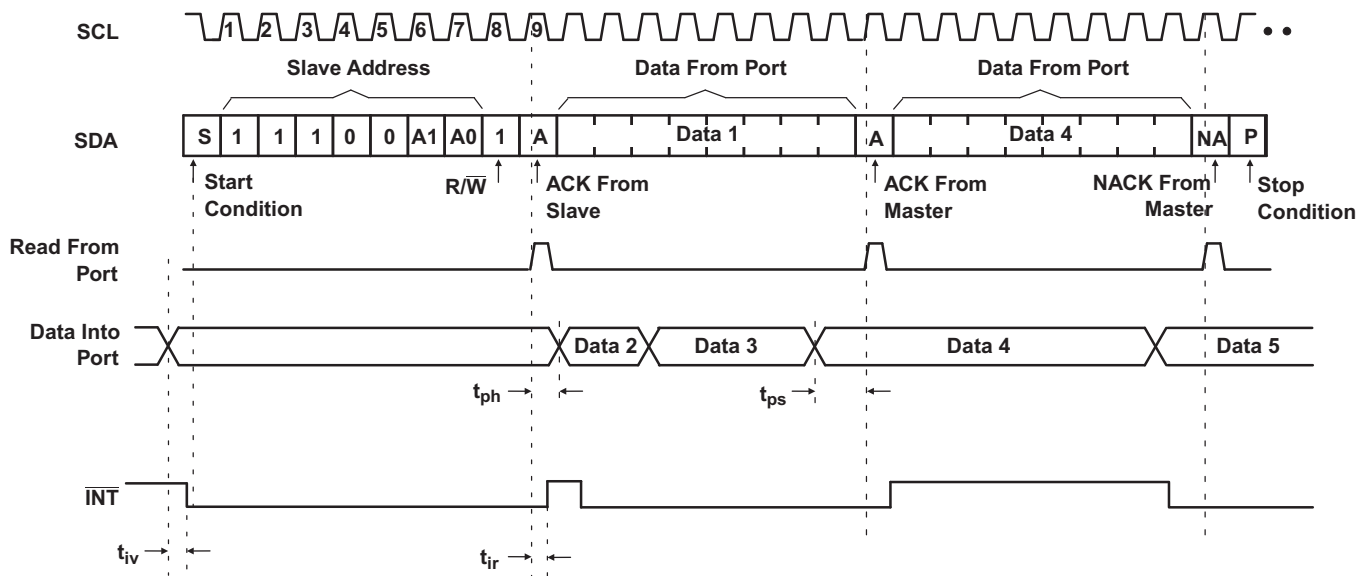

Figure 21. Write to Configuration or Polarity Inversion Registers

8.6.3.1.2 Reads

The bus master first must send the TCA9538 address with the LSB set to a logic 0 (see [Figure 18](#) for device address). The command byte is sent after the address and determines which register is accessed. After a restart, the device address is sent again but, this time, the LSB is set to a logic 1. Data from the register defined by the command byte then is sent by the TCA9538 (see [Figure 22](#) and [Figure 23](#)). After a restart, the value of the register defined by the command byte matches the register being accessed when the restart occurred. Data is clocked into the register on the rising edge of the ACK clock pulse. There is no limitation on the number of data bytes received in one read transmission, but when the final byte is received, the bus master must not acknowledge the data.

Figure 22. Read From Register

- This figure assumes the command byte has previously been programmed with 00h.
- Transfer of data can be stopped at any moment by a Stop condition.
- This figure eliminates the command byte transfer, a restart, and slave address call between the initial slave address call and actual data transfer from the P port. See [Figure 22](#) for these details.

Figure 23. Read From Input Port Register

9 Application and Implementation

NOTE

Information in the following applications sections is not part of the TI component specification, and TI does not warrant its accuracy or completeness. TI's customers are responsible for determining suitability of components for their purposes. Customers should validate and test their design implementation to confirm system functionality.

9.1 Application Information

Figure 24 shows an application in which the TCA9538 can be used.

9.2 Typical Application

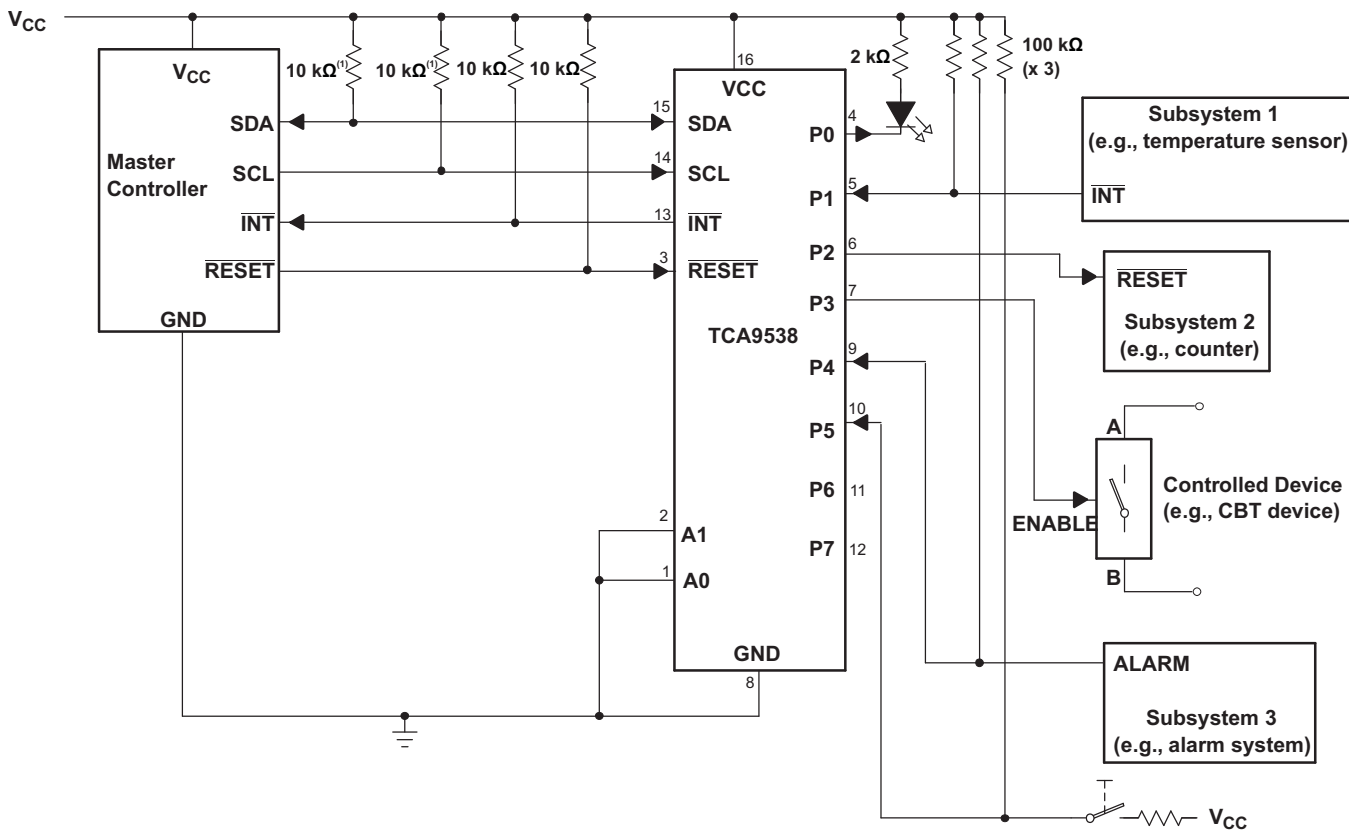

- (1) The SCL and SDA pins must be tied directly to VCC because if SCL and SDA are tied to an auxiliary power supply that could be powered on while VCC is powered off, then the supply current, ICC, increases as a result.
- A. Device address is configured as 1110000 for this example.
- B. P0, P2, and P3 are configured as outputs.
- C. P1, P4, and P5 are configured as inputs.
- D. P6 and P7 are not used and must be configured as outputs.

Figure 24. Application Schematic

Typical Application (continued)

9.2.1 Design Requirements

9.2.1.1 Minimizing I_{CC} When I/Os Control LEDs

When the I/Os are used to control LEDs, normally they are connected to V_{CC} through a resistor as shown in Figure 24. For a P-port configured as an input, I_{CC} increases as V_I becomes lower than V_{CC} . The LED is a diode, with threshold voltage V_T , and when a P-port is configured as an input the LED is off but V_I is a V_T drop below V_{CC} .

For battery-powered applications, it is essential that the voltage of P-ports controlling LEDs is greater than or equal to V_{CC} when the P-ports are configured as input to minimize current consumption. Figure 25 shows a high-value resistor in parallel with the LED. Figure 26 shows V_{CC} less than the LED supply voltage by at least V_T . Both of these methods maintain the I/O V_I at or above V_{CC} and prevents additional supply current consumption when the P-port is configured as an input and the LED is off.

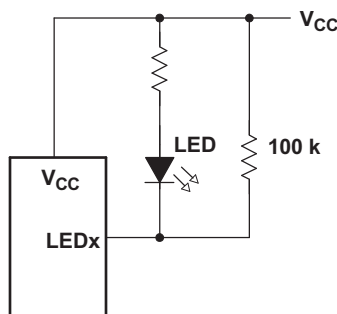

Figure 25. High-Value Resistor in Parallel with LED

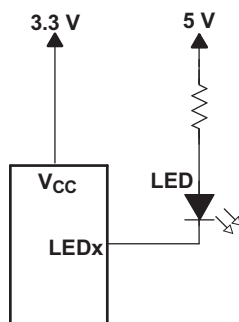

Figure 26. Device Supplied by a Lower Voltage

9.2.2 Detailed Design Procedure

The pull-up resistors, R_P , for the SCL and SDA lines need to be selected appropriately and take into consideration the total capacitance of all slaves on the I^2C bus. The minimum pull-up resistance is a function of V_{CC} , $V_{OL(max)}$, and I_{OL} as shown in Equation 1:

$$R_{p(min)} = \frac{V_{CC} - V_{OL(max)}}{I_{OL}} \quad (1)$$

The maximum pull-up resistance is a function of the maximum rise time, t_r (300 ns for fast-mode operation, $f_{SCL} = 400$ kHz) and bus capacitance, C_b as shown in Equation 2:

$$R_{p(max)} = \frac{t_r}{0.8473 \times C_b} \quad (2)$$

The maximum bus capacitance for an I^2C bus must not exceed 400 pF for standard-mode or fast-mode operation. The bus capacitance can be approximated by adding the capacitance of the TCA9538, C_i for SCL or C_{i0} for SDA, the capacitance of wires/connections/traces, and the capacitance of additional slaves on the bus.

Typical Application (continued)

9.2.3 Application Curves

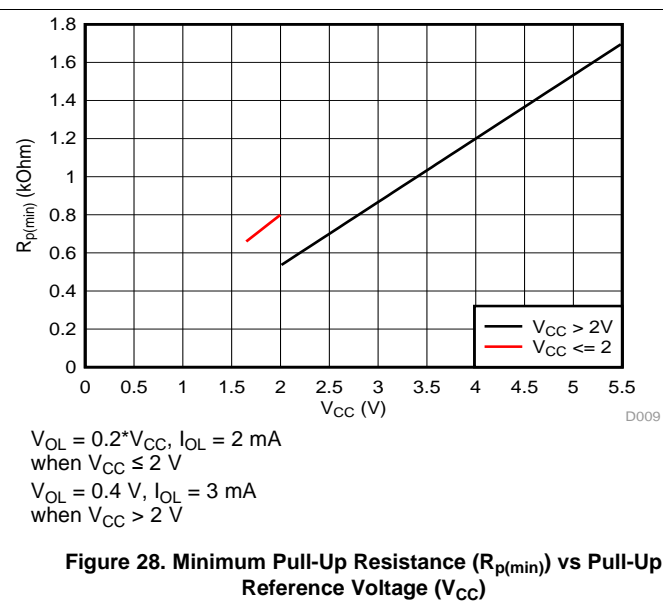
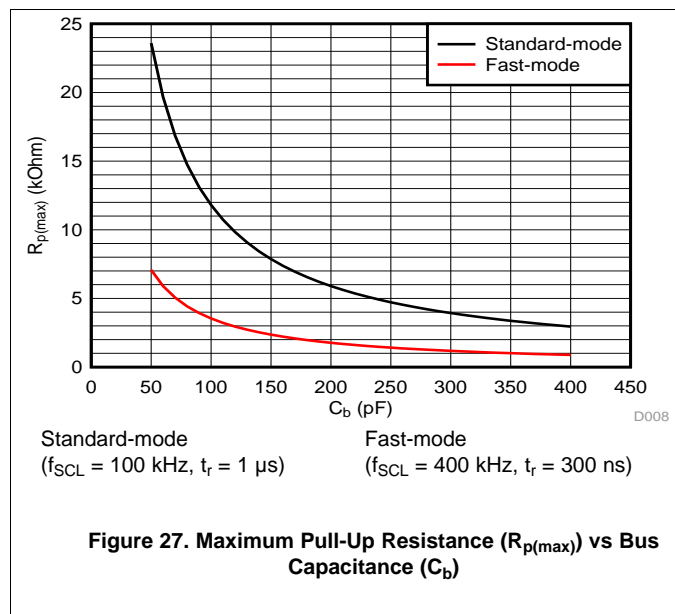

10 Power Supply Recommendations

10.1 Power-On Reset Requirements

In the event of a glitch or data corruption, the TCA9538 can be reset to its default conditions by using the power-on reset feature. Power-on reset requires that the device go through a power cycle to be completely reset. This reset also happens when the device is powered on for the first time in an application.

The two types of power-on reset are shown in and [Figure 29](#).

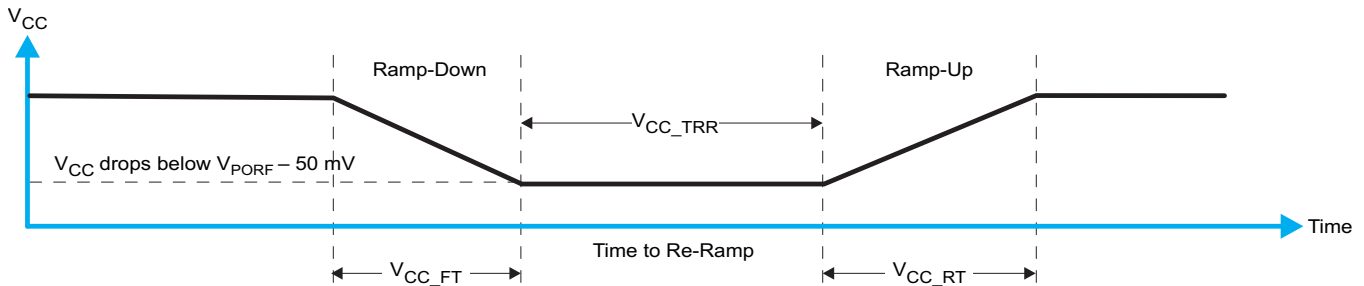

Figure 29. V_{CC} is Lowered Below the POR Threshold, Then Ramped Back Up to V_{CC}

[Table 8](#) specifies the performance of the power-on reset feature for the TCA9538 for both types of power-on reset.

Table 8. Recommended Supply Sequencing And Ramp Rates⁽¹⁾

PARAMETER		MIN	MAX	UNIT
V_{CC_FT}	Fall rate	See Figure 29	1	ms
V_{CC_RT}	Rise rate	See Figure 29	0.1	ms
V_{CC_TRR}	Time to re-ramp (when V_{CC} drops to $V_{POR_MIN} - 50$ mV or when V_{CC} drops to GND)	See Figure 29	2	μ s
V_{CC_GH}	Level that V_{CC} can glitch down to, but not cause a functional disruption when $V_{CC_GW} = 1$ μ s	See Figure 30	1.2	V
V_{CC_GW}	Glitch width that does not cause a functional disruption when $V_{CC_GH} = 0.5 \times V_{CC}$ (For $V_{CC} > 3$ V)	See Figure 30	10	μ s

(1) All supply sequencing and ramp rate values are measured at $T_A = 25^\circ\text{C}$

Glitches in the power supply can also affect the power-on reset performance of this device. The glitch width (V_{CC_GW}) and height (V_{CC_GH}) are dependent on each other. The bypass capacitance, source impedance, and device impedance are factors that affect power-on reset performance. [Figure 30](#) and [Table 8](#) provide more information on how to measure these specifications.

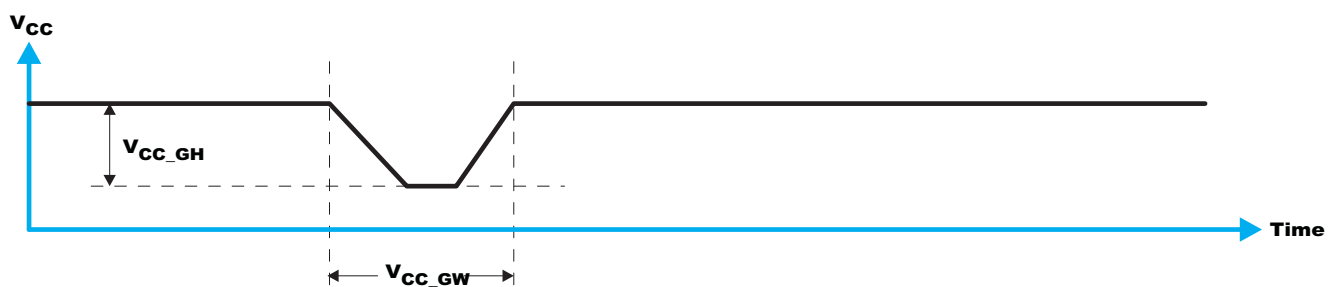

Figure 30. Glitch Width and Glitch Height

V_{POR} is critical to the power-on reset. V_{POR} is the voltage level at which the reset condition is released and all the registers and the I²C/SMBus state machine are initialized to their default states. The value of V_{POR} differs based on the V_{CC} being lowered to or from 0. [Figure 31](#) and [Table 8](#) provide more details on this specification.

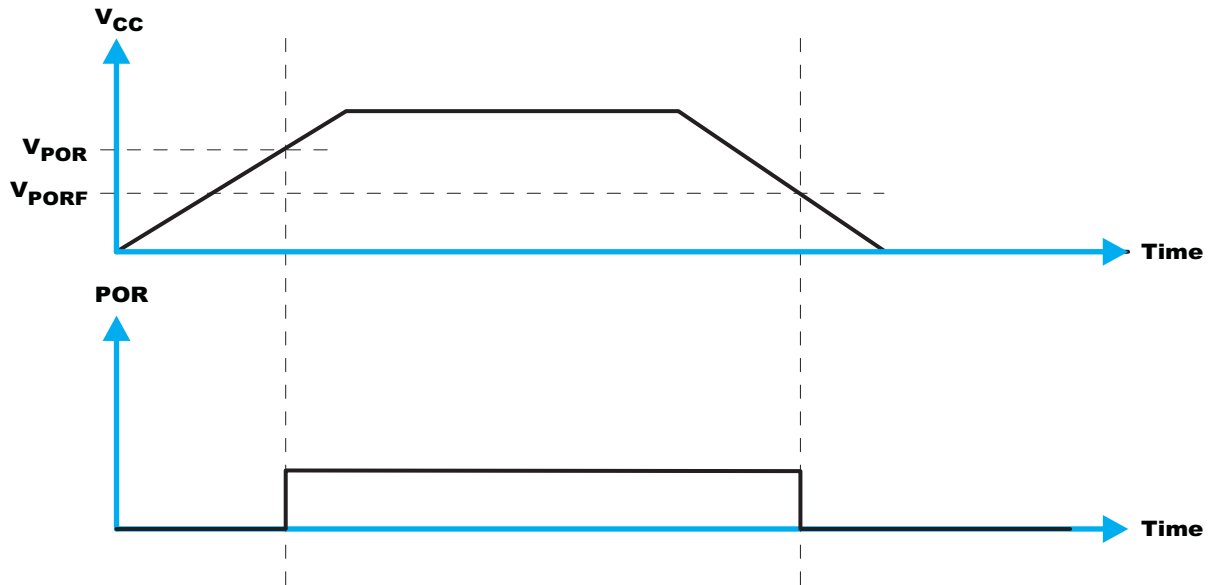

Figure 31. V_{POR}

11 Layout

11.1 Layout Guidelines

For printed circuit board (PCB) layout of the TCA9538, common PCB layout practices must be followed but additional concerns related to high-speed data transfer such as matched impedances and differential pairs are not a concern for I²C signal speeds.

In all PCB layouts, it is a best practice to avoid right angles in signal traces, to fan out signal traces away from each other upon leaving the vicinity of an integrated circuit (IC), and to use thicker trace widths to carry higher amounts of current that commonly pass through power and ground traces. By-pass and de-coupling capacitors are commonly used to control the voltage on the VCC pin, using a larger capacitor to provide additional power in the event of a short power supply glitch and a smaller capacitor to filter out high-frequency ripple. These capacitors must be placed as close to the TCA9538 as possible. These best practices are shown in Figure 32.

For the layout example provided in Figure 32, it would be possible to fabricate a PCB with only 2 layers by using the top layer for signal routing and the bottom layer as a split plane for power (V_{CC}) and ground (GND). However, a 4 layer board is preferable for boards with higher density signal routing. On a 4 layer PCB, it is common to route signals on the top and bottom layer, dedicate one internal layer to a ground plane, and dedicate the other internal layer to a power plane. In a board layout using planes or split planes for power and ground, vias are placed directly next to the surface mount component pad which needs to attach to V_{CC} or GND and the via is connected electrically to the internal layer or the other side of the board. Vias are also used when a signal trace needs to be routed to the opposite side of the board, but this technique is not demonstrated in Figure 32.

11.2 Layout Example

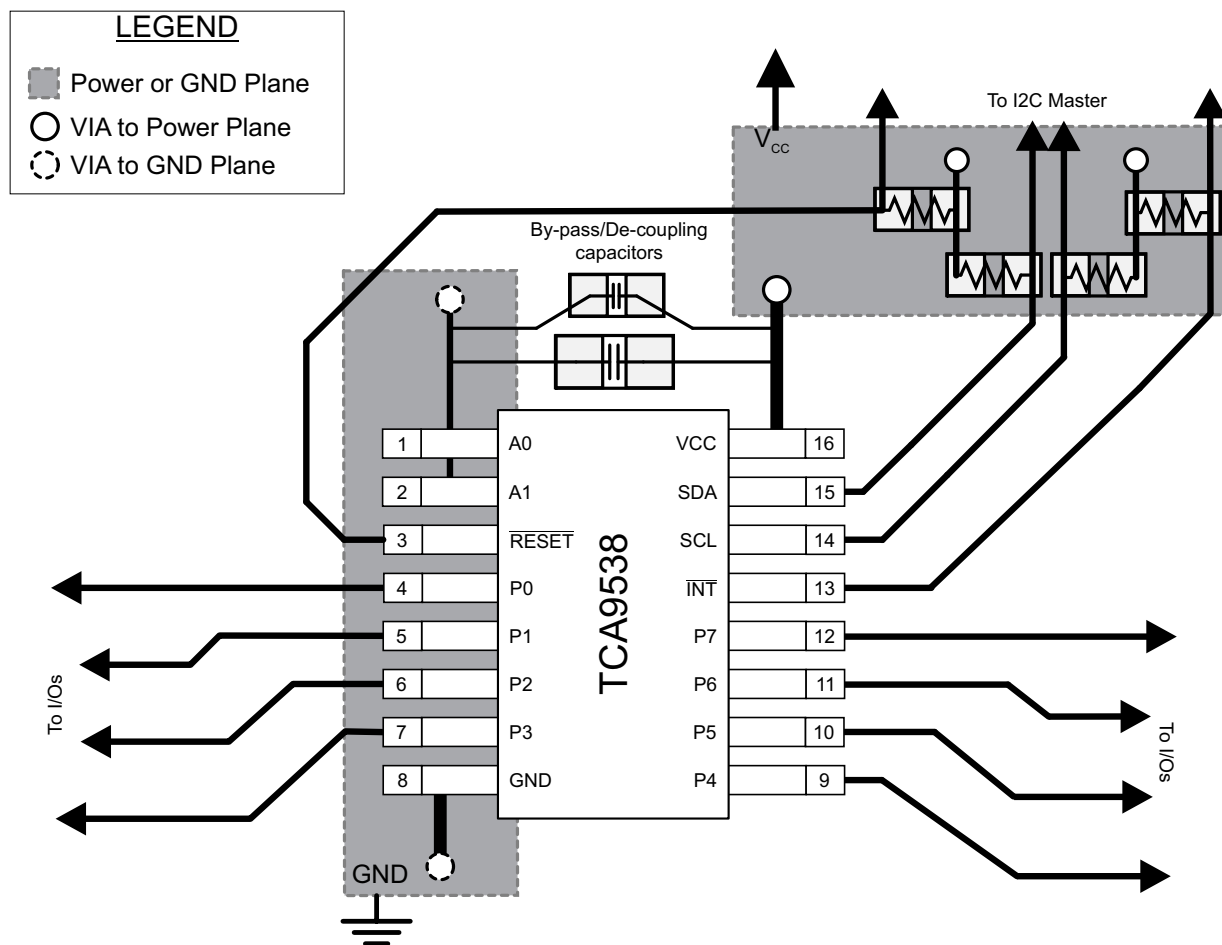

Figure 32. TCA9538 Layout

12 器件和文档支持

12.1 文档支持

12.1.1 相关文档

相关文档请参见以下部分：

- 《I2C 总线上拉电阻计算》
- 《I2C 总线在采用中继器时的最高时钟频率》
- 《逻辑器件简介》
- 《理解 I2C 总线》
- 《为新设计挑选合适的 I2C 器件》
- 《I/O 扩展器 EVM 用户指南》

12.2 接收文档更新通知

如需接收文档更新通知，请访问 ti.com 上的器件产品文件夹。点击右上角的提醒我 (Alert me) 注册后，即可每周定期收到已更改的产品信息。有关更改的详细信息，请查阅已修订文档中包含的修订历史记录。

12.3 社区资源

The following links connect to TI community resources. Linked contents are provided "AS IS" by the respective contributors. They do not constitute TI specifications and do not necessarily reflect TI's views; see TI's [Terms of Use](#).

TI E2E™ Online Community *TI's Engineer-to-Engineer (E2E) Community*. Created to foster collaboration among engineers. At e2e.ti.com, you can ask questions, share knowledge, explore ideas and help solve problems with fellow engineers.

Design Support *TI's Design Support* Quickly find helpful E2E forums along with design support tools and contact information for technical support.

12.4 商标

E2E is a trademark of Texas Instruments.
All other trademarks are the property of their respective owners.

12.5 静电放电警告



ESD 可能会损坏该集成电路。德州仪器 (TI) 建议通过适当的预防措施处理所有集成电路。如果不遵守正确的处理措施和安装程序，可能会损坏集成电路。

ESD 的损坏小至导致微小的性能降级，大至整个器件故障。精密的集成电路可能更容易受到损坏，这是因为非常细微的参数更改都可能会导致器件与其发布的规格不相符。

12.6 Glossary

[SLYZ022](#) — *TI Glossary*.

This glossary lists and explains terms, acronyms, and definitions.

13 机械、封装和可订购信息

以下页中包括机械、封装和可订购信息。这些信息是针对指定器件可提供的最新数据。这些数据会在无通知且不对本文档进行修订的情况下发生改变。欲获得该数据表的浏览器版本，请查阅左侧的导航栏。

PACKAGING INFORMATION

Orderable part number	Status (1)	Material type (2)	Package Pins	Package qty Carrier	RoHS (3)	Lead finish/ Ball material (4)	MSL rating/ Peak reflow (5)	Op temp (°C)	Part marking (6)
TCA9538DBR	Active	Production	SSOP (DB) 16	2000 LARGE T&R	Yes	NIPDAU	Level-1-260C-UNLIM	-40 to 85	TD538
TCA9538DBR.A	Active	Production	SSOP (DB) 16	2000 LARGE T&R	Yes	NIPDAU	Level-1-260C-UNLIM	-40 to 85	TD538
TCA9538DBR.B	Active	Production	SSOP (DB) 16	2000 LARGE T&R	Yes	NIPDAU	Level-1-260C-UNLIM	-40 to 85	TD538
TCA9538DBRG4	Active	Production	SSOP (DB) 16	2000 LARGE T&R	Yes	NIPDAU	Level-1-260C-UNLIM	-40 to 85	TD538
TCA9538DBRG4.A	Active	Production	SSOP (DB) 16	2000 LARGE T&R	Yes	NIPDAU	Level-1-260C-UNLIM	-40 to 85	TD538
TCA9538DBRG4.B	Active	Production	SSOP (DB) 16	2000 LARGE T&R	Yes	NIPDAU	Level-1-260C-UNLIM	-40 to 85	TD538
TCA9538PWR	Active	Production	TSSOP (PW) 16	2000 LARGE T&R	Yes	NIPDAU SN	Level-1-260C-UNLIM	-40 to 85	PW538
TCA9538PWR.A	Active	Production	TSSOP (PW) 16	2000 LARGE T&R	Yes	NIPDAU	Level-1-260C-UNLIM	-40 to 85	PW538
TCA9538PWR.B	Active	Production	TSSOP (PW) 16	2000 LARGE T&R	Yes	NIPDAU	Level-1-260C-UNLIM	-40 to 85	PW538
TCA9538PWRG4	Active	Production	TSSOP (PW) 16	2000 LARGE T&R	Yes	NIPDAU	Level-1-260C-UNLIM	-40 to 85	PW538
TCA9538PWRG4.A	Active	Production	TSSOP (PW) 16	2000 LARGE T&R	Yes	NIPDAU	Level-1-260C-UNLIM	-40 to 85	PW538
TCA9538PWRG4.B	Active	Production	TSSOP (PW) 16	2000 LARGE T&R	Yes	NIPDAU	Level-1-260C-UNLIM	-40 to 85	PW538

(1) **Status:** For more details on status, see our [product life cycle](#).

(2) **Material type:** When designated, preproduction parts are prototypes/experimental devices, and are not yet approved or released for full production. Testing and final process, including without limitation quality assurance, reliability performance testing, and/or process qualification, may not yet be complete, and this item is subject to further changes or possible discontinuation. If available for ordering, purchases will be subject to an additional waiver at checkout, and are intended for early internal evaluation purposes only. These items are sold without warranties of any kind.

(3) **RoHS values:** Yes, No, RoHS Exempt. See the [TI RoHS Statement](#) for additional information and value definition.

(4) **Lead finish/Ball material:** Parts may have multiple material finish options. Finish options are separated by a vertical ruled line. Lead finish/Ball material values may wrap to two lines if the finish value exceeds the maximum column width.

(5) **MSL rating/Peak reflow:** The moisture sensitivity level ratings and peak solder (reflow) temperatures. In the event that a part has multiple moisture sensitivity ratings, only the lowest level per JEDEC standards is shown. Refer to the shipping label for the actual reflow temperature that will be used to mount the part to the printed circuit board.

(6) **Part marking:** There may be an additional marking, which relates to the logo, the lot trace code information, or the environmental category of the part.

Multiple part markings will be inside parentheses. Only one part marking contained in parentheses and separated by a "-" will appear on a part. If a line is indented then it is a continuation of the previous line and the two combined represent the entire part marking for that device.

Important Information and Disclaimer: The information provided on this page represents TI's knowledge and belief as of the date that it is provided. TI bases its knowledge and belief on information provided by third parties, and makes no representation or warranty as to the accuracy of such information. Efforts are underway to better integrate information from third parties. TI has taken and continues to take reasonable steps to provide representative and accurate information but may not have conducted destructive testing or chemical analysis on incoming materials and chemicals. TI and TI suppliers consider certain information to be proprietary, and thus CAS numbers and other limited information may not be available for release.

In no event shall TI's liability arising out of such information exceed the total purchase price of the TI part(s) at issue in this document sold by TI to Customer on an annual basis.

TAPE AND REEL INFORMATION

QUADRANT ASSIGNMENTS FOR PIN 1 ORIENTATION IN TAPE

*All dimensions are nominal

Device	Package Type	Package Drawing	Pins	SPQ	Reel Diameter (mm)	Reel Width W1 (mm)	A0 (mm)	B0 (mm)	K0 (mm)	P1 (mm)	W (mm)	Pin1 Quadrant
TCA9538DBR	SSOP	DB	16	2000	330.0	16.4	8.35	6.6	2.4	12.0	16.0	Q1
TCA9538DBRG4	SSOP	DB	16	2000	330.0	16.4	8.35	6.6	2.4	12.0	16.0	Q1
TCA9538PWR	TSSOP	PW	16	2000	330.0	12.4	6.9	5.6	1.6	8.0	12.0	Q1
TCA9538PWR	TSSOP	PW	16	2000	330.0	12.4	6.9	5.6	1.6	8.0	12.0	Q1
TCA9538PWRG4	TSSOP	PW	16	2000	330.0	12.4	6.9	5.6	1.6	8.0	12.0	Q1

TAPE AND REEL BOX DIMENSIONS

*All dimensions are nominal

Device	Package Type	Package Drawing	Pins	SPQ	Length (mm)	Width (mm)	Height (mm)
TCA9538DBR	SSOP	DB	16	2000	353.0	353.0	32.0
TCA9538DBRG4	SSOP	DB	16	2000	353.0	353.0	32.0
TCA9538PWR	TSSOP	PW	16	2000	356.0	356.0	35.0
TCA9538PWR	TSSOP	PW	16	2000	353.0	353.0	32.0
TCA9538PWRG4	TSSOP	PW	16	2000	353.0	353.0	32.0

DB0016A



PACKAGE OUTLINE

SSOP - 2 mm max height

SMALL OUTLINE PACKAGE

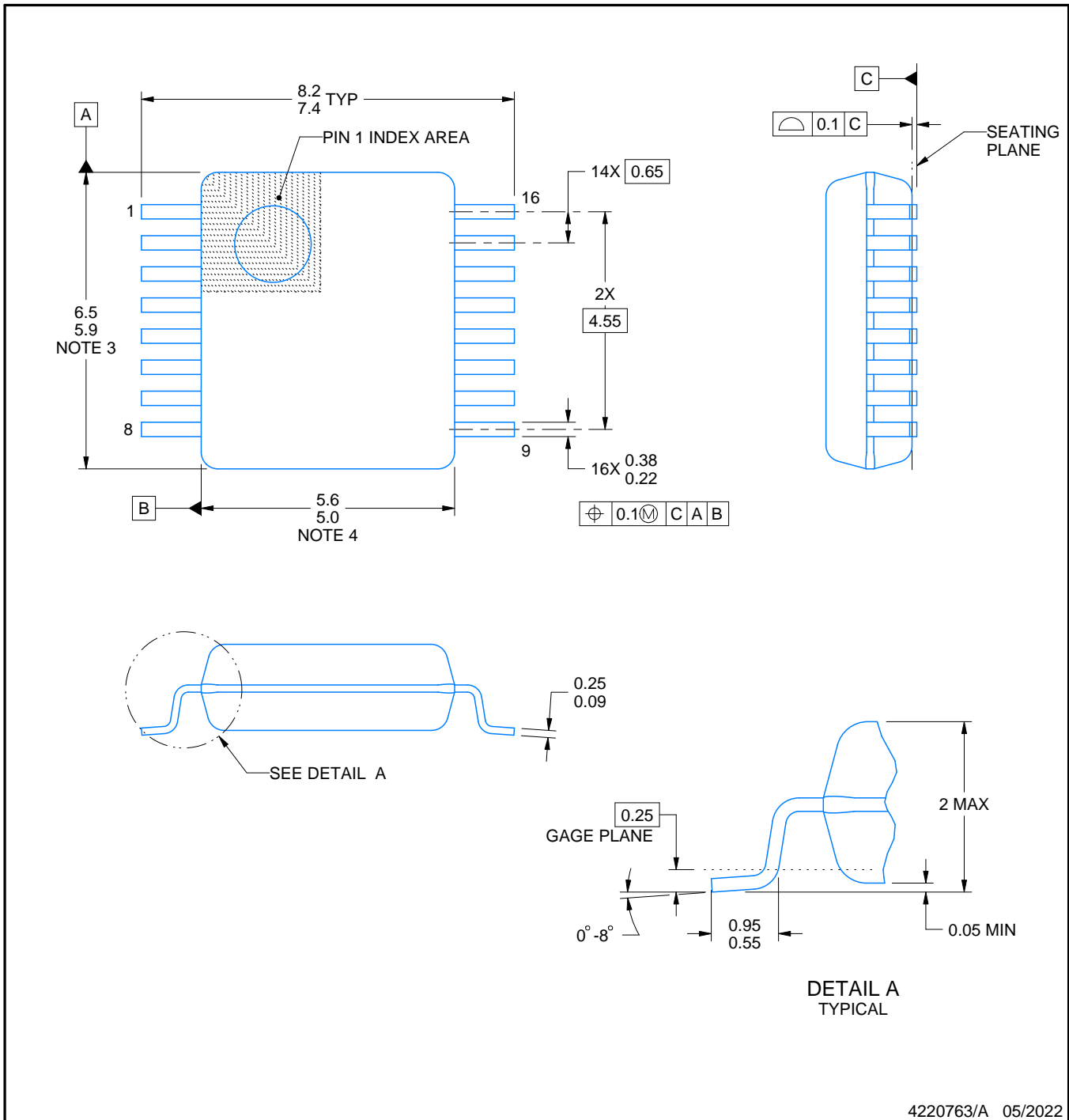

4220763/A 05/2022

NOTES:

- All linear dimensions are in millimeters. Any dimensions in parenthesis are for reference only. Dimensioning and tolerancing per ASME Y14.5M.
- This drawing is subject to change without notice.
- This dimension does not include mold flash, protrusions, or gate burrs. Mold flash, protrusions, or gate burrs shall not exceed 0.15 mm per side.
- Reference JEDEC registration MO-150.

EXAMPLE BOARD LAYOUT

DB0016A

SSOP - 2 mm max height

SMALL OUTLINE PACKAGE

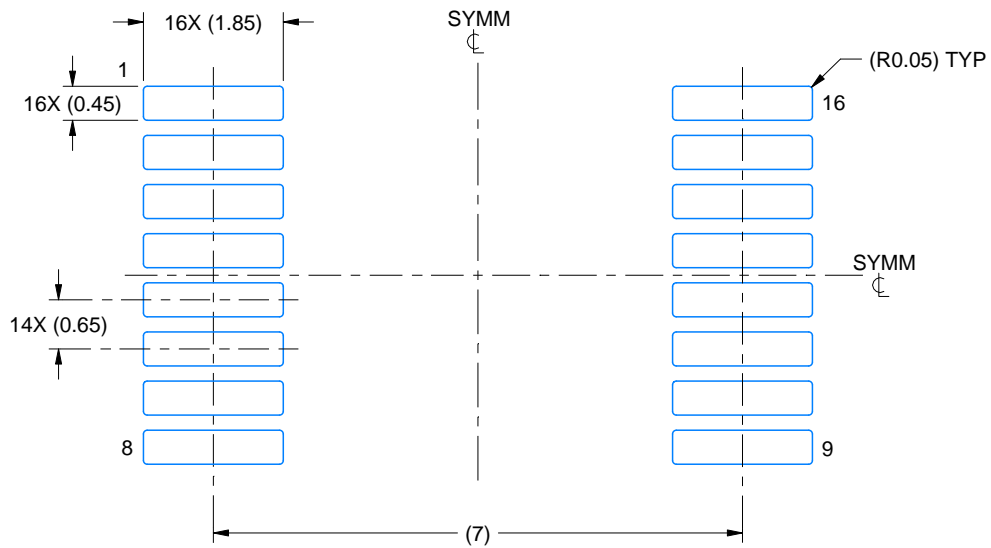

LAND PATTERN EXAMPLE
EXPOSED METAL SHOWN
SCALE: 10X

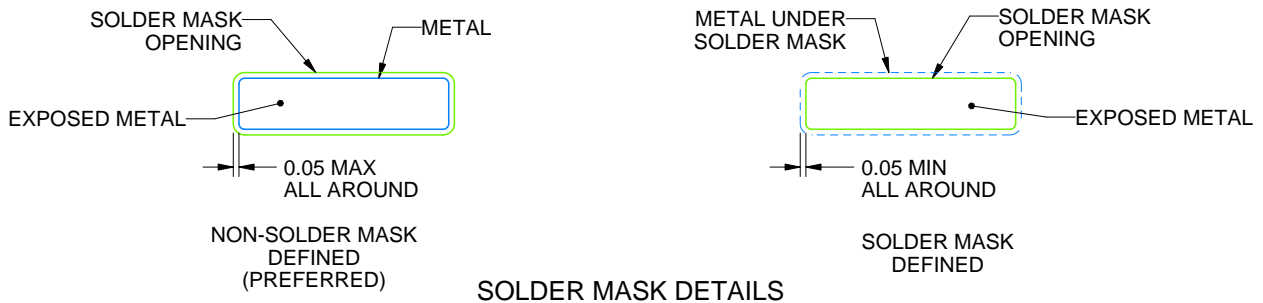

4220763/A 05/2022

NOTES: (continued)

- 5. Publication IPC-7351 may have alternate designs.
- 6. Solder mask tolerances between and around signal pads can vary based on board fabrication site.

EXAMPLE STENCIL DESIGN

DB0016A

SSOP - 2 mm max height

SMALL OUTLINE PACKAGE

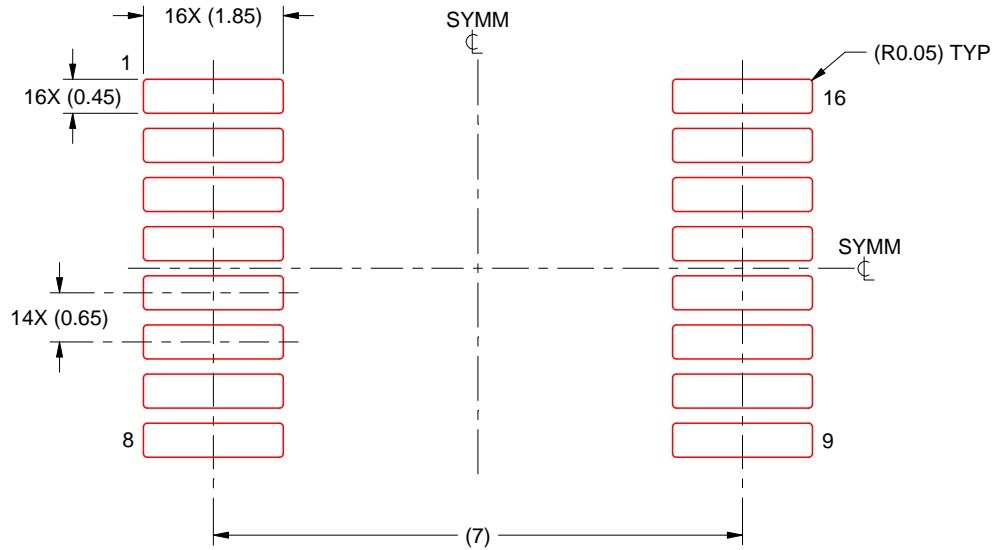

SOLDER PASTE EXAMPLE
BASED ON 0.125 mm THICK STENCIL
SCALE: 10X

4220763/A 05/2022

NOTES: (continued)

7. Laser cutting apertures with trapezoidal walls and rounded corners may offer better paste release. IPC-7525 may have alternate design recommendations.
8. Board assembly site may have different recommendations for stencil design.

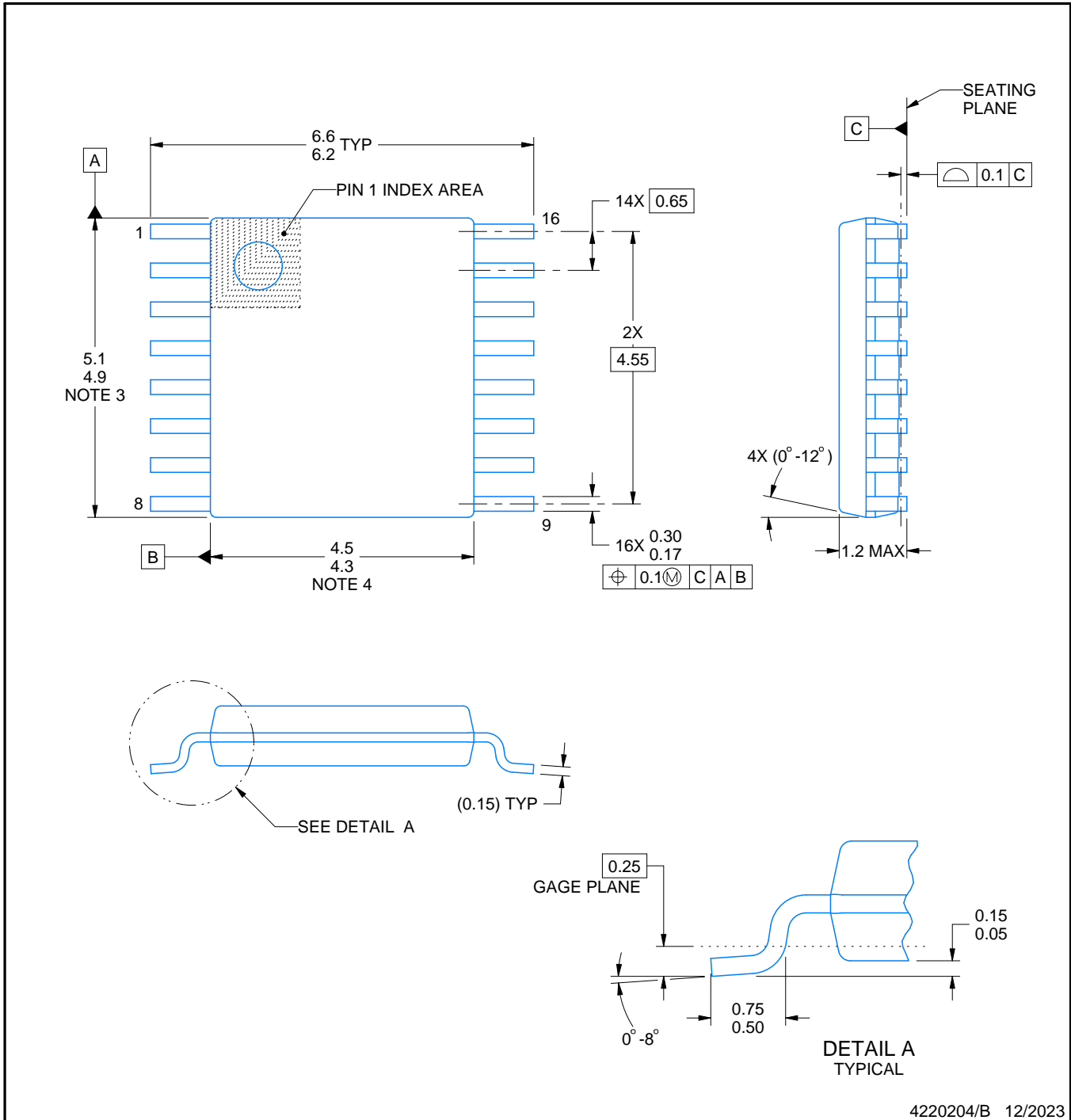

4220204/B 12/2023

NOTES:

1. All linear dimensions are in millimeters. Any dimensions in parenthesis are for reference only. Dimensioning and tolerancing per ASME Y14.5M.
2. This drawing is subject to change without notice.
3. This dimension does not include mold flash, protrusions, or gate burrs. Mold flash, protrusions, or gate burrs shall not exceed 0.15 mm per side.
4. This dimension does not include interlead flash. Interlead flash shall not exceed 0.25 mm per side.
5. Reference JEDEC registration MO-153.

EXAMPLE BOARD LAYOUT

PW0016A

TSSOP - 1.2 mm max height

SMALL OUTLINE PACKAGE

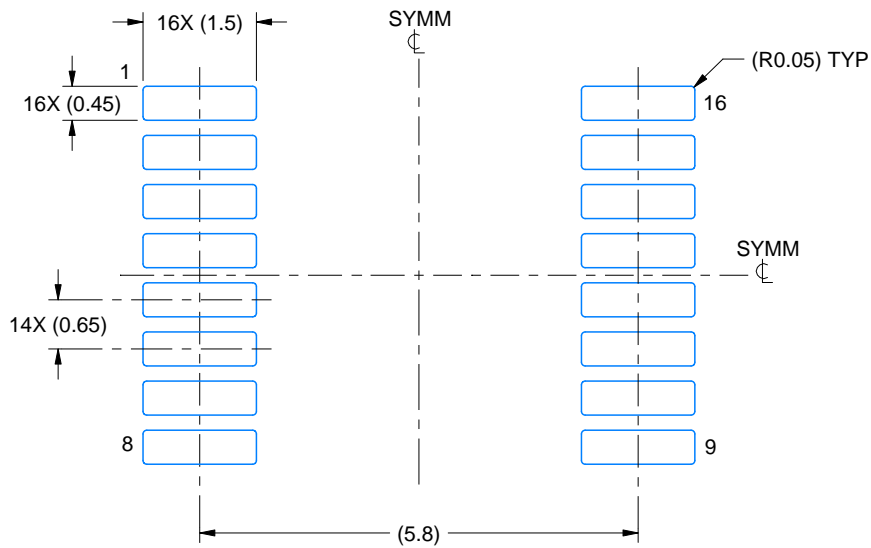

LAND PATTERN EXAMPLE
EXPOSED METAL SHOWN
SCALE: 10X

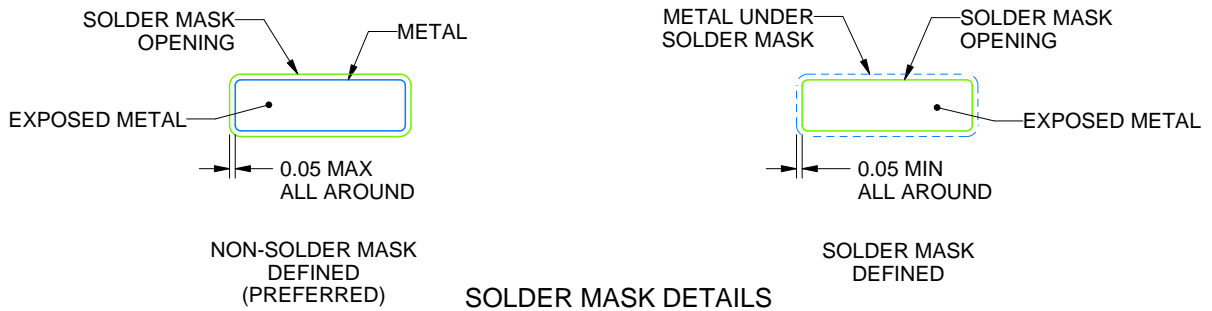

SOLDER MASK DETAILS

4220204/B 12/2023

NOTES: (continued)

- 6. Publication IPC-7351 may have alternate designs.
- 7. Solder mask tolerances between and around signal pads can vary based on board fabrication site.

EXAMPLE STENCIL DESIGN

PW0016A

TSSOP - 1.2 mm max height

SMALL OUTLINE PACKAGE

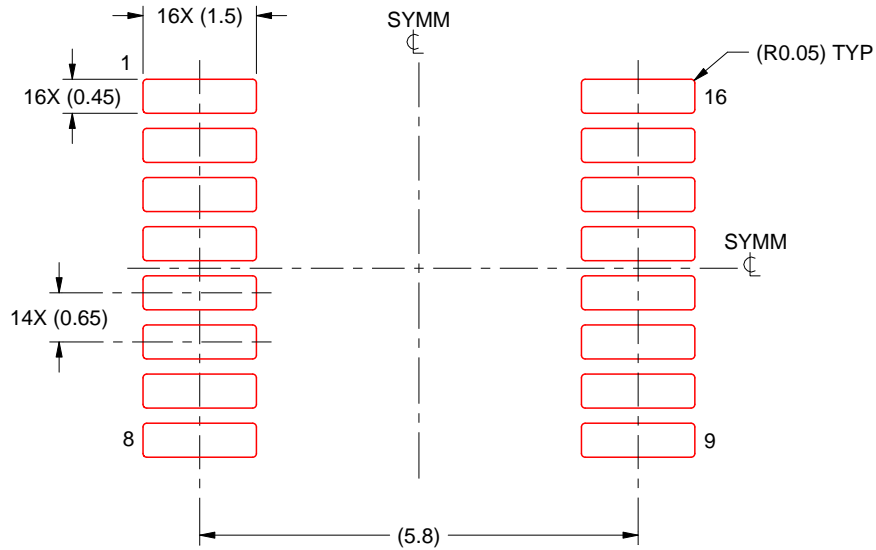

SOLDER PASTE EXAMPLE
BASED ON 0.125 mm THICK STENCIL
SCALE: 10X

4220204/B 12/2023

NOTES: (continued)

8. Laser cutting apertures with trapezoidal walls and rounded corners may offer better paste release. IPC-7525 may have alternate design recommendations.
9. Board assembly site may have different recommendations for stencil design.

重要通知和免责声明

TI“按原样”提供技术和可靠性数据（包括数据表）、设计资源（包括参考设计）、应用或其他设计建议、网络工具、安全信息和其他资源，不保证没有瑕疵且不做任何明示或暗示的担保，包括但不限于对适销性、与某特定用途的适用性或不侵犯任何第三方知识产权的暗示担保。

这些资源可供使用 TI 产品进行设计的熟练开发人员使用。您将自行承担以下全部责任：(1) 针对您的应用选择合适的 TI 产品，(2) 设计、验证并测试您的应用，(3) 确保您的应用满足相应标准以及任何其他安全、安保法规或其他要求。

这些资源如有变更，恕不另行通知。TI 授权您仅可将这些资源用于研发本资源所述的 TI 产品的相关应用。严禁以其他方式对这些资源进行复制或展示。您无权使用任何其他 TI 知识产权或任何第三方知识产权。对于因您对这些资源的使用而对 TI 及其代表造成的任何索赔、损害、成本、损失和债务，您将全额赔偿，TI 对此概不负责。

TI 提供的产品受 [TI 销售条款](#)、[TI 通用质量指南](#) 或 [ti.com](#) 上其他适用条款或 TI 产品随附的其他适用条款的约束。TI 提供这些资源并不会扩展或以其他方式更改 TI 针对 TI 产品发布的适用的担保或担保免责声明。除非德州仪器 (TI) 明确将某产品指定为定制产品或客户特定产品，否则其产品均为按确定价格收入目录的标准通用器件。

TI 反对并拒绝您可能提出的任何其他或不同的条款。

版权所有 © 2026，德州仪器 (TI) 公司

最后更新日期：2025 年 10 月