

TCA9543A 具有中断逻辑电路和复位功能的低压 2 通道 I²C 总线开关

1 特性

- 2 选 1 双向转换开关
- 与 I²C 总线和系统管理总线 (SMBus) 兼容
- 两个低电平有效中断输入
- 低电平有效中断输出
- 低电平有效复位输入
- 两个地址引脚，允许在 I²C 总线上支持多达四个 TCA9543A 器件
- 通过 I²C 总线进行通道选择，可任意组合
- 上电时所有开关通道取消选定
- 低 R_{ON} 开关
- 支持在 1.8V、2.5V、3.3V 和 5V 总线间进行电压电平转换
- 上电时无干扰
- 支持热插入
- 低待机电流
- 工作电源电压范围为 1.65V 至 5.5V
- 5.5V 耐压输入
- 0 至 400kHz 时钟频率
- 闩锁性能超过 100mA，符合 JESD78 规范
- ESD 保护性能超过 JESD 22 规范要求
 - 4000V 人体放电模型 (A114-A)
 - 1500V 充电器件模型 (C101)

2 应用

- 服务器
- 路由器（电信交换设备）
- 工厂自动化
- 具有 I²C 从器件地址冲突（多个完全一样的温度传感器）的产品

3 说明

TCA9543A 是一款由 I²C 总线控制的双路双向转换开关。串行时钟/串行数据 (SCL/SDA) 上行对扩展到 2 个下行对，或者通道。根据可编程控制寄存器的内容，可选择任一单独的 SC_n/SD_n 通道或者这两个通道。提供两个中断输入 ($\overline{INT1}$ - $\overline{INT0}$)，每个中断输入针对一个下行对。一个中断输出 (\overline{INT}) 可作为两个中断输入的与 (AND) 操作。

一个低电平有效复位 (\overline{RESET}) 输入使得 TCA9543A 能够在其中一个下行 I²C 总线长时间处于低电平的情况下恢复。将 \overline{RESET} 下拉为低电平会使 I²C 状态机复位，并且使这两个通道取消选中，这一功能与内部加电复位功能的作用一样。

在开关上建有导通栅极，这样的话，VCC 引脚可被用于限制将由 TCA9543A 传递的最大高压。这允许在每个对上使用不同的总线电压，以便 1.8V、2.5V 或 3.3V 部件可以在没有任何额外保护的情况下与 5V 部件通信。对于每个通道，外部上拉电阻器将总线电压上拉至所需的电压水平。所有 I/O 引脚可耐受 5.5V 电压。

器件信息⁽¹⁾

器件型号	封装	封装尺寸 (标称值)
TCA9543A	TSSOP (14)	5.00mm × 4.40mm
	SOIC (14)	8.65mm × 3.91mm

(1) 要了解所有可用封装，请见数据表末尾的可订购产品附录。

简化应用示意图

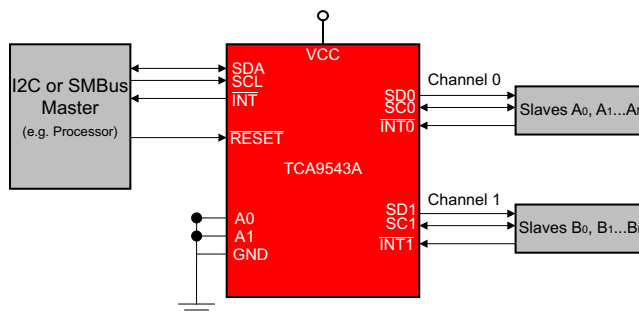

目录

1	特性	1	8.3	Feature Description	12
2	应用	1	8.4	Device Functional Modes	12
3	说明	1	8.5	Programming	12
4	修订历史记录	2	8.6	Register Maps	14
5	Pin Configuration and Functions	3	9	Application and Implementation	17
6	Specifications	4	9.1	Application Information	17
6.1	Absolute Maximum Ratings	4	9.2	Typical Application	17
6.2	ESD Ratings	4	10	Power Supply Recommendations	20
6.3	Recommended Operating Conditions	4	10.1	Power-On Reset Requirements	20
6.4	Thermal Information	4	11	Layout	22
6.5	Electrical Characteristics	5	11.1	Layout Guidelines	22
6.6	I ² C Interface Timing Requirements	6	11.2	Layout Example	22
6.7	Switching Characteristics	7	12	器件和文档支持	23
6.8	Interrupt and Reset Timing Requirements	7	12.1	接收文档更新通知	23
6.9	Typical Characteristics	8	12.2	支持资源	23
7	Parameter Measurement Information	9	12.3	商标	23
8	Detailed Description	11	12.4	静电放电警告	23
8.1	Overview	11	12.5	Glossary	23
8.2	Functional Block Diagram	11	13	机械、封装和可订购信息	23

4 修订历史记录

Changes from Revision A (February 2015) to Revision B	Page
• Changed the Pin Configuration images appearance	3
• Changed $V_{CC} = 3.3\text{ V}$ to $V_{CC} = 2.5\text{ V}$ in Figure 16	17

Changes from Original (September 2012) to Revision A	Page
• 已添加 添加了引脚配置和功能 部分、ESD 额定值表、特性 说明 部分、器件功能模式、应用和实施 部分、电源相关建议 部分、布局 部分、器件和文档支持 部分以及机械、封装和可订购信息 部分	1
• 已添加 向数据表添加了 D 封装	1
• Changed Handling Ratings table to ESD Ratings	4
• Added D package to the Thermal Information table.	4

5 Pin Configuration and Functions

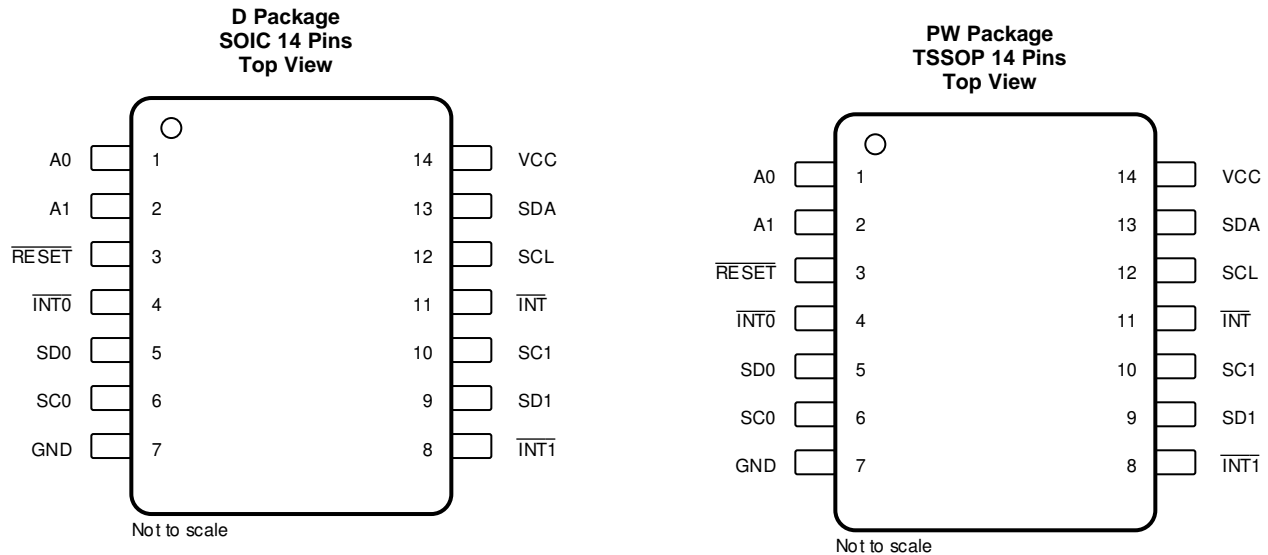

Pin Functions

PIN		DESCRIPTION
NO.	NAME	
1	A0	Address input 0. Connect directly to V_{CC} or ground.
2	A1	Address input 1. Connect directly to V_{CC} or ground.
3	$\overline{\text{RESET}}$	Active-low reset input. Connect to V_{CC} or $V_{DPUM}^{(1)}$ through a pull-up resistor, if not used.
4	$\overline{\text{INT0}}$	Active-low interrupt input 0. Connect to $V_{DPU0}^{(1)}$ through a pull-up resistor.
5	SD0	Serial data 0. Connect to $V_{DPU0}^{(1)}$ through a pull-up resistor.
6	SC0	Serial clock 0. Connect to $V_{DPU0}^{(1)}$ through a pull-up resistor.
7	GND	Ground
8	$\overline{\text{INT1}}$	Active-low interrupt input 1. Connect to $V_{DPU1}^{(1)}$ through a pull-up resistor.
9	SD1	Serial data 1. Connect to $V_{DPU1}^{(1)}$ through a pull-up resistor.
10	SC1	Serial clock 1. Connect to $V_{DPU1}^{(1)}$ through a pull-up resistor.
11	$\overline{\text{INT}}$	Active-low interrupt output. Connect to $V_{DPUM}^{(1)}$ through a pull-up resistor.
12	SCL	Serial clock line. Connect to $V_{DPUM}^{(1)}$ through a pull-up resistor.
13	SDA	Serial data line. Connect to $V_{DPUM}^{(1)}$ through a pull-up resistor.
14	VCC	Supply power

(1) V_{DPUX} is the pull-up reference voltage for the associated data line. V_{DPUM} is the master I²C reference voltage while V_{DPU0} and V_{DPU1} are the slave channel reference voltages.

6 Specifications

6.1 Absolute Maximum Ratings⁽¹⁾

over operating free-air temperature range (unless otherwise noted)

		MIN	MAX	UNIT
V _{CC}	Supply voltage range	-0.5	7	V
V _I	Input voltage range ⁽²⁾	-0.5	7	V
I _I	Input current		±20	mA
I _O	Output current		±25	mA
	Continuous current through VCC		±100	mA
	Continuous current through GND		±100	mA
P _{tot}	Total power dissipation		400	mW
T _A	Operating free-air temperature range	-40	85	°C
T _{stg}	Storage temperature range	-60	150	°C

- (1) Stresses beyond those listed under “absolute maximum ratings” may cause permanent damage to the device. These are stress ratings only, and functional operation of the device at these or any other conditions beyond those indicated under “recommended operating conditions” is not implied. Exposure to absolute-maximum-rated conditions for extended periods may affect device reliability.
- (2) The input negative-voltage and output voltage ratings may be exceeded if the input and output current ratings are observed.

6.2 ESD Ratings

		VALUE	UNIT
V _(ESD)	Electrostatic discharge	Human-body model (HBM), per ANSI/ESDA/JEDEC JS-001 ⁽¹⁾	±4000
		Charged-device model (CDM), per JEDEC specification JESD22-C101 ⁽²⁾	±1500

- (1) JEDEC document JEP155 states that 500-V HBM allows safe manufacturing with a standard ESD control process.
- (2) JEDEC document JEP157 states that 250-V CDM allows safe manufacturing with a standard ESD control process.

6.3 Recommended Operating Conditions⁽¹⁾

		MIN	MAX	UNIT
V _{CC}	Supply voltage	1.65	5.5	V
V _{IH}	High-level input voltage	SCL, SDA	0.7 × V _{CC}	6
		A1, A0, INT1, INT0, RESET	0.7 × V _{CC}	V _{CC} + 0.5
V _{IL}	Low-level input voltage	SCL, SDA	-0.5	0.3 × V _{CC}
		A1, A0, INT1, INT0, RESET	-0.5	0.3 × V _{CC}
T _A	Operating free-air temperature	-40	85	°C

- (1) All unused inputs of the device must be held at V_{CC} or GND to ensure proper device operation. Refer to the TI application report, *Implications of Slow or Floating CMOS Inputs*, literature number [SCBA004](#).

6.4 Thermal Information

THERMAL METRIC ⁽¹⁾	TCA9543A		UNIT	
	PW	D		
	14 PINS	14 PINS		
R _{θJA}	Junction-to-ambient thermal resistance	130.9	102.8	°C/W
R _{θJctop}	Junction-to-case (top) thermal resistance	59.2	63.9	
R _{θJB}	Junction-to-board thermal resistance	72.7	57.1	
ψ _{JT}	Junction-to-top characterization parameter	10.5	26.7	
ψ _{JB}	Junction-to-board characterization parameter	72.1	56.8	

- (1) For more information about traditional and new thermal metrics, see the *Semiconductor and IC Package Thermal Metrics* application report.

6.5 Electrical Characteristics⁽¹⁾

over recommended operating free-air temperature range (unless otherwise noted)

PARAMETER		TEST CONDITIONS	V _{CC}	MIN	TYP ⁽²⁾	MAX	UNIT	
V _{PORR}	Power-on reset voltage, VCC rising	No load: V _I = V _{CC} or GND ⁽³⁾			1.2	1.5	V	
V _{PORF}	Power-on reset voltage, VCC falling ⁽⁴⁾	No load: V _I = V _{CC} or GND ⁽³⁾		0.8	1		V	
V _{pass}	Switch output voltage	V _{SWin} = V _{CC} , I _{SWout} = -100 μA	5 V		3.6		V	
			4.5 V to 5.5 V		2.6	4.5		
			3.3 V		1.9			
			3 V to 3.6 V	1.6		2.8		
			2.5 V		1.4			
			2.3 V to 2.7 V	1.0		1.8		
			1.8 V		0.8			
			1.65 V to 1.95 V	0.5		1.1		
I _{OH}	$\overline{\text{INT}}$	V _O = V _{CC}	1.65 V to 5.5 V			10	μA	
I _{OL}	SDA	V _{OL} = 0.4 V	1.65 V to 5.5 V	3	7		mA	
		V _{OL} = 0.6 V		6	10			
	$\overline{\text{INT}}$	V _{OL} = 0.4 V		3				
I _I	SCL, SDA	V _I = V _{CC} or GND ⁽³⁾	1.65 V to 5.5 V	-1		1	μA	
	SC1–SC0, SD1–SD0	V _I = V _{CC} or GND ⁽³⁾	1.65 V to 5.5 V	-1		1		
	A1, A0	V _I = V _{CC} or GND ⁽³⁾	1.65 V to 5.5 V	-1		1		
	$\overline{\text{INT1}}\text{--}\overline{\text{INT0}}$	V _I = V _{CC} or GND ⁽³⁾	1.65 V to 5.5 V	-1		1		
	$\overline{\text{RESET}}$	V _I = V _{CC} or GND ⁽³⁾	1.65 V to 5.5 V	-1		1		
I _{CC}	Operating mode	f _{SCL} = 400 kHz V _I = V _{CC} or GND ⁽³⁾ I _O = 0 t _{r,max} = 300 ns	5.5 V		50		μA	
			3.6 V		20			
			2.7 V		11			
			1.65 V		6			
			5.5 V		35			
			3.6 V		14			
			2.7 V		5			
	1.65 V		2					
	Standby mode	Low inputs	V _I = GND ⁽³⁾ I _O = 0	5.5 V		1.6		2
				3.6 V		1.0		1.3
				2.7 V		0.7		1.1
				1.65 V		0.4		0.55
		High inputs	V _I = V _{CC} I _O = 0	5.5 V		1.6		2
				3.6 V		1.0		1.3
2.7 V					0.7	1.1		
			1.65 V		0.4	0.55		
ΔI _{CC}	Supply-current change	$\overline{\text{INT1}}\text{--}\overline{\text{INT0}}$	One $\overline{\text{INT1}}\text{--}\overline{\text{INT0}}$ input at 0.6 V, Other inputs at V _{CC} or GND ⁽³⁾	1.65 V to 5.5 V	3	20	μA	
			One $\overline{\text{INT1}}\text{--}\overline{\text{INT0}}$ input at V _{CC} - 0.6 V, Other inputs at V _{CC} or GND ⁽³⁾		3	20		
		SCL, SDA	SCL or SDA input at 0.6 V, Other inputs at V _{CC} or GND ⁽³⁾		2	15		
			SCL or SDA input at V _{CC} - 0.6 V, Other inputs at V _{CC} or GND ⁽³⁾		2	15		

(1) For operation between specified voltage ranges, refer to the worst-case parameter in both applicable ranges.

(2) All typical values are at nominal supply voltage (1.8-V, 2.5-V, 3.3-V, or 5-V V_{CC}), T_A = 25°C.

(3) $\overline{\text{RESET}}$ = V_{CC} (held high) when all other input voltages, V_I = GND

(4) The power-on reset circuit resets the I²C bus logic when V_{CC} < V_{PORF}.

Electrical Characteristics⁽¹⁾ (continued)

over recommended operating free-air temperature range (unless otherwise noted)

PARAMETER		TEST CONDITIONS	V _{CC}	MIN	TYP ⁽²⁾	MAX	UNIT
C _i	A1, A0	V _I = V _{CC} or GND ⁽³⁾	1.65 V to 5.5 V	4.5	6		pF
	$\overline{\text{INT1}}\text{--}\overline{\text{INT0}}$	V _I = V _{CC} or GND ⁽³⁾	1.65 V to 5.5 V	4.5	6		
	$\overline{\text{RESET}}$	V _I = V _{CC} or GND ⁽³⁾	1.65 V to 5.5 V	4.5	5.5		
C _{io(OFF)} ⁽⁵⁾	SCL, SDA	V _I = V _{CC} or GND ⁽³⁾ , Switch OFF	1.65 V to 5.5 V	15	19		pF
	SC1–SC0, SD1–SD0			6	8		
R _{ON}	Switch on-state resistance	V _O = 0.4 V, I _O = 15 mA	4.5 V to 5.5 V	4	10	16	Ω
			3 V to 3.6 V	5	13	20	
		V _O = 0.4 V, I _O = 10 mA	2.3 V to 2.7 V	7	16	45	
			1.65 V to 1.95 V	10	25	70	

 (5) C_{io(ON)} depends on the device capacitance and load that is downstream from the device.

6.6 I²C Interface Timing Requirements

over recommended operating free-air temperature range (unless otherwise noted) (see Figure 5)

		STANDARD MODE I ² C BUS		FAST MODE I ² C BUS		UNIT
		MIN	MAX	MIN	MAX	
f _{scl}	I ² C clock frequency	0	100	0	400	kHz
t _{sch}	I ² C clock high time	4		0.6		μs
t _{scl}	I ² C clock low time	4.7		1.3		μs
t _{sp}	I ² C spike time		50		50	ns
t _{sds}	I ² C serial-data setup time	250		100		ns
t _{sdh}	I ² C serial-data hold time	0 ⁽¹⁾		0 ⁽¹⁾		μs
t _{icr}	I ² C input rise time		1000	20 + 0.1C _b ⁽²⁾	300	ns
t _{icf}	I ² C input fall time		300	20 + 0.1C _b ⁽²⁾	300	ns
t _{ocf}	I ² C output fall time	10-pF to 400-pF bus	300	20 + 0.1C _b ⁽²⁾	300	ns
t _{buf}	I ² C bus free time between stop and start		4.7	1.3		μs
t _{sts}	I ² C start or repeated start condition setup		4.7	0.6		μs
t _{sth}	I ² C start or repeated start condition hold		4	0.6		μs
t _{sps}	I ² C stop condition setup		4	0.6		μs
t _{vdL(Data)}	Valid-data time (high to low) ⁽³⁾	SCL low to SDA output low valid	1		1	μs
t _{vdH(Data)}	Valid-data time (low to high) ⁽³⁾	SCL low to SDA output high valid	0.6		0.6	μs
t _{vd(ack)}	Valid-data time of ACK condition	ACK signal from SCL low to SDA output low	1		1	μs
C _b	I ² C bus capacitive load		400		400	pF

 (1) A device internally must provide a hold time of at least 300-ns for the SDA signal (referred to as the V_{IH} min of the SCL signal), in order to bridge the undefined region of the falling edge of SCL.

 (2) C_b = total bus capacitance of one bus line in pF

(3) Data taken using a 1-kΩ pullup resistor and 50-pF load (see Figure 5)

6.7 Switching Characteristics

over recommended operating free-air temperature range, $C_L \leq 100$ pF (unless otherwise noted) (see [Figure 7](#))

PARAMETER		FROM (INPUT)	TO (OUTPUT)	MIN	MAX	UNIT
$t_{pd}^{(1)}$	Propagation delay time	$R_{ON} = 20 \Omega, C_L = 15$ pF	SDA or SCL	SDn or SCn	0.3	ns
		$R_{ON} = 20 \Omega, C_L = 50$ pF			1	
t_{iv}	Interrupt valid time ⁽²⁾	\overline{INTn}	\overline{INT}		4	μ s
t_{ir}	Interrupt reset delay time ⁽²⁾	\overline{INTn}	\overline{INT}		2	μ s

(1) The propagation delay is the calculated RC time constant of the typical ON-state resistance of the switch and the specified load capacitance, when driven by an ideal voltage source (zero output impedance).

(2) Data taken using a 4.7-k Ω pullup resistor and 100-pF load (see [Figure 7](#))

6.8 Interrupt and Reset Timing Requirements

over recommended operating free-air temperature range (unless otherwise noted) (see [Figure 7](#))

PARAMETER		MIN	MAX	UNIT
t_{PWRL}	Required low-level pulse duration of \overline{INTn} inputs ⁽¹⁾	1		μ s
t_{PWRH}	Required high-level pulse duration of \overline{INTn} inputs ⁽¹⁾	0.5		μ s
t_{WL}	Pulse duration, \overline{RESET} low	4		ns
$t_{rst}^{(2)}$	\overline{RESET} time (SDA clear)		500	ns
t_{REC}	Recovery time from \overline{RESET} to start	0		ns

(1) The device has interrupt input rejection circuitry for pulses less than the listed minimum.

(2) t_{rst} is the propagation delay measured from the time the \overline{RESET} terminal is first asserted low to the time the SDA terminal is asserted high, signaling a stop condition. It must be a minimum of t_{WL} .

6.9 Typical Characteristics

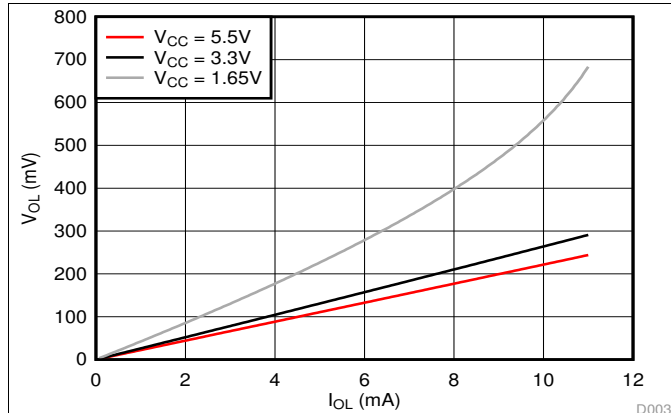

Figure 1. SDA Output Low Voltage (V_{OL}) vs Load Current (I_{OL}) at Three V_{CC} Levels

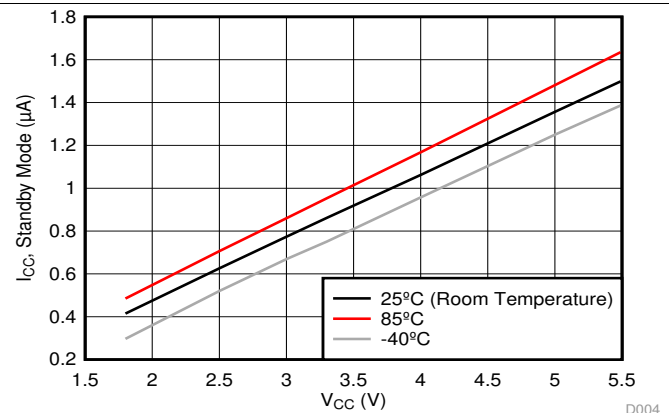

Figure 2. Standby Current (I_{CC}) vs Supply Voltage (V_{CC}) at Three Temperature Points

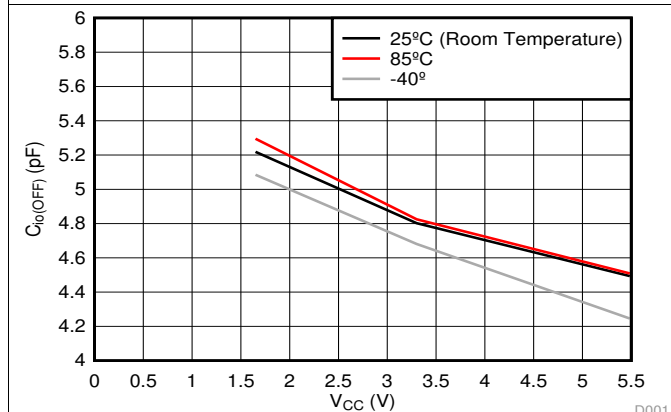

Figure 3. Slave channel (SCn/SDn) capacitance ($C_{io(OFF)}$) vs. Supply Voltage (V_{CC}) at Three Temperature Points

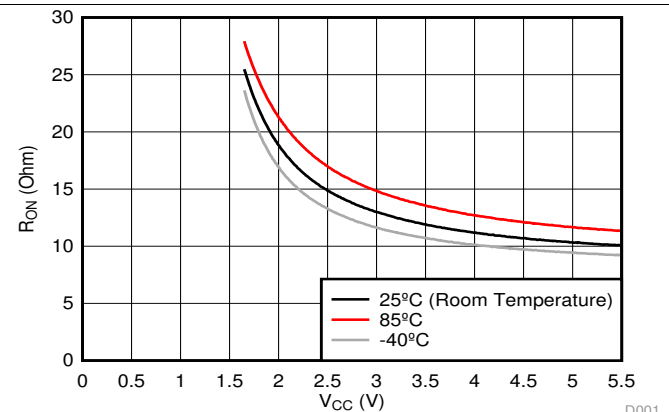
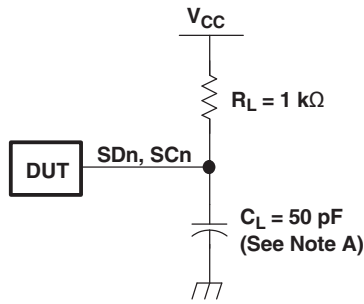
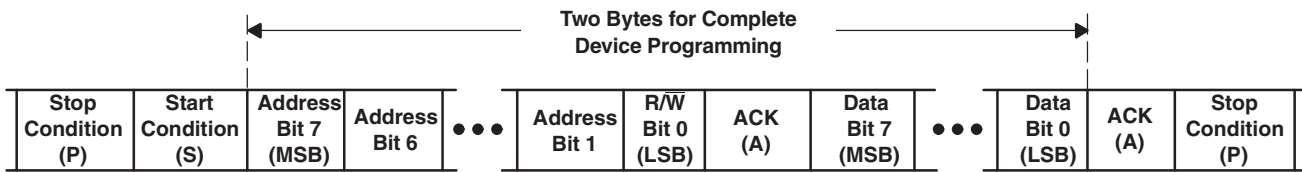

Figure 4. ON-Resistance (R_{ON}) vs Supply Voltage (V_{CC}) at Three Temperatures

7 Parameter Measurement Information



I²C PORT LOAD CONFIGURATION



BYTE	DESCRIPTION
1	I ² C address + R/W
2	Control register data

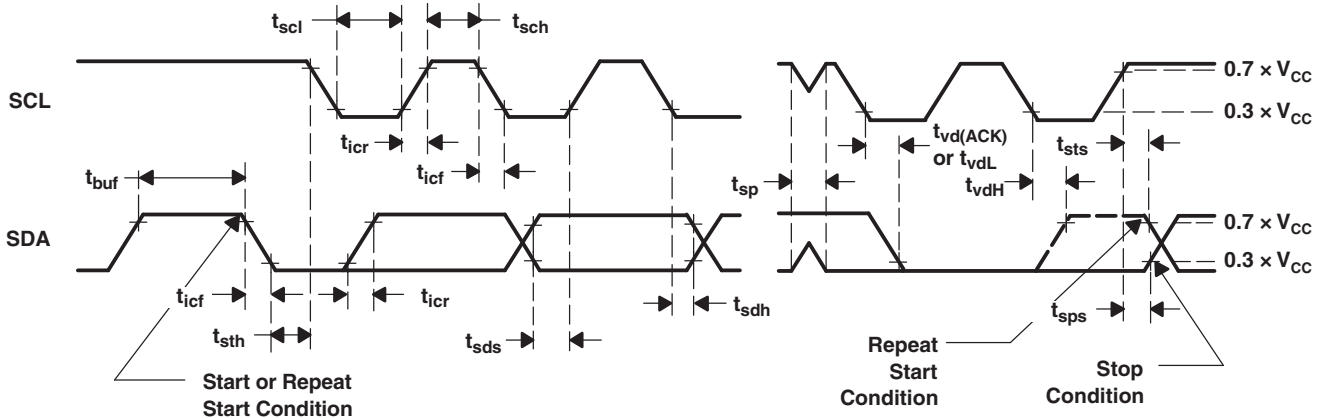

VOLTAGE WAVEFORMS

- A. C_L includes probe and jig capacitance.
- B. All input pulses are supplied by generators having the following characteristics: $PRR \leq 10$ MHz, $Z_O = 50 \Omega$, $t_r/t_f = 30$ ns.
- C. The outputs are measured one at a time, with one transition per measurement.

Figure 5. I²C Interface Load Circuit, Byte Descriptions, and Voltage Waveforms

Parameter Measurement Information (continued)

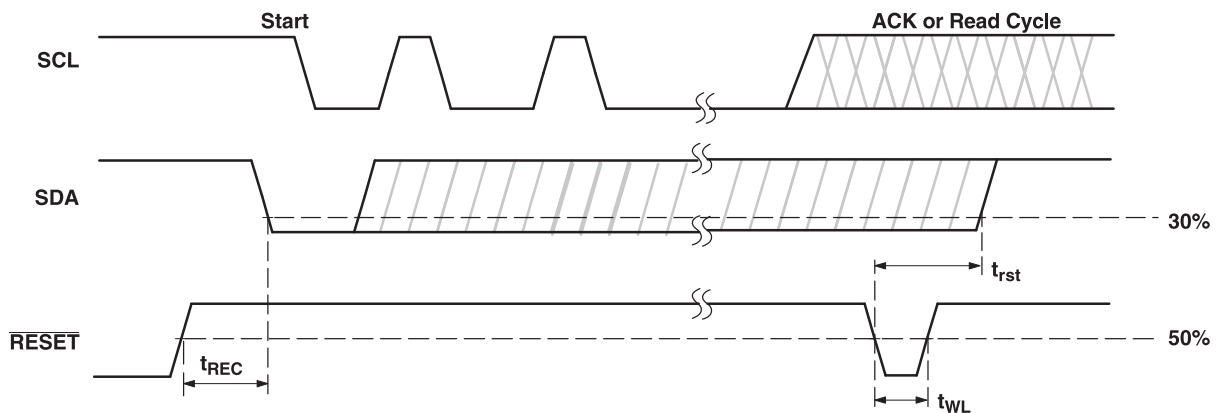
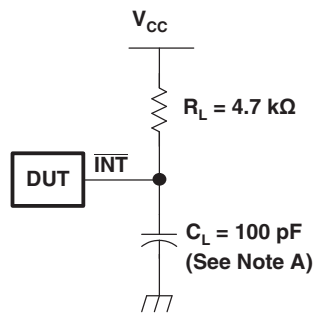
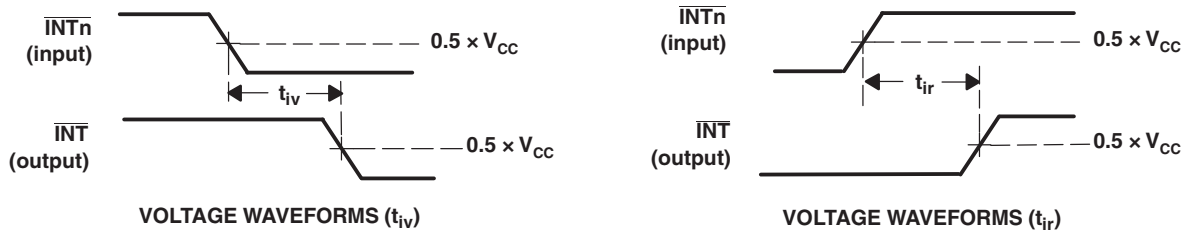

Figure 6. Reset Timing



INTERRUPT LOAD CONFIGURATION



- A. C_L includes probe and jig capacitance.
- B. All input pulses are supplied by generators having the following characteristics: $PRR \leq 10 \text{ MHz}$, $Z_O = 50 \Omega$, $t_r/t_f = 30 \text{ ns}$.

Figure 7. Interrupt Load Circuit and Voltage Waveforms

8 Detailed Description

8.1 Overview

The TCA9543A is a 2-channel, bidirectional translating I²C switch. The master SCL/SDA signal pair is directed to two channels of slave devices, SC0/SD0-SC1/SD1. Either individual downstream channel can be selected as well as both channels. The TCA9543A also supports interrupt signals in order for the master to detect an interrupt on the $\overline{\text{INT}}$ output terminal that can result from any of the slave devices connected to the $\overline{\text{INT1}}$ - $\overline{\text{INT0}}$ input terminals.

The device offers an active-low $\overline{\text{RESET}}$ input which resets the state machine and allows the TCA9543A to recover should one of the downstream I²C buses get stuck in a low state. The state machine of the device can also be reset by cycling the power supply, V_{CC}, also known as a power-on reset (POR). Either using the $\overline{\text{RESET}}$ function or causing a POR will cause both channels to be deselected.

The connections of the I²C data path are controlled by the same I²C master device that is switched to communicate with multiple I²C slaves. After the successful acknowledgment of the slave address (hardware selectable by A0 and A1 terminals), a single 8-bit control register is written to or read from to determine the selected channels and state of the interrupts.

The TCA9543A may also be used for voltage translation, allowing the use of different bus voltages on each SCn/SDn pair such that 1.8-V, 2.5-V, or 3.3-V parts can communicate with 5-V parts. This is achieved by using external pull-up resistors to pull the bus up to the desired voltage for the master and each slave channel.

8.2 Functional Block Diagram

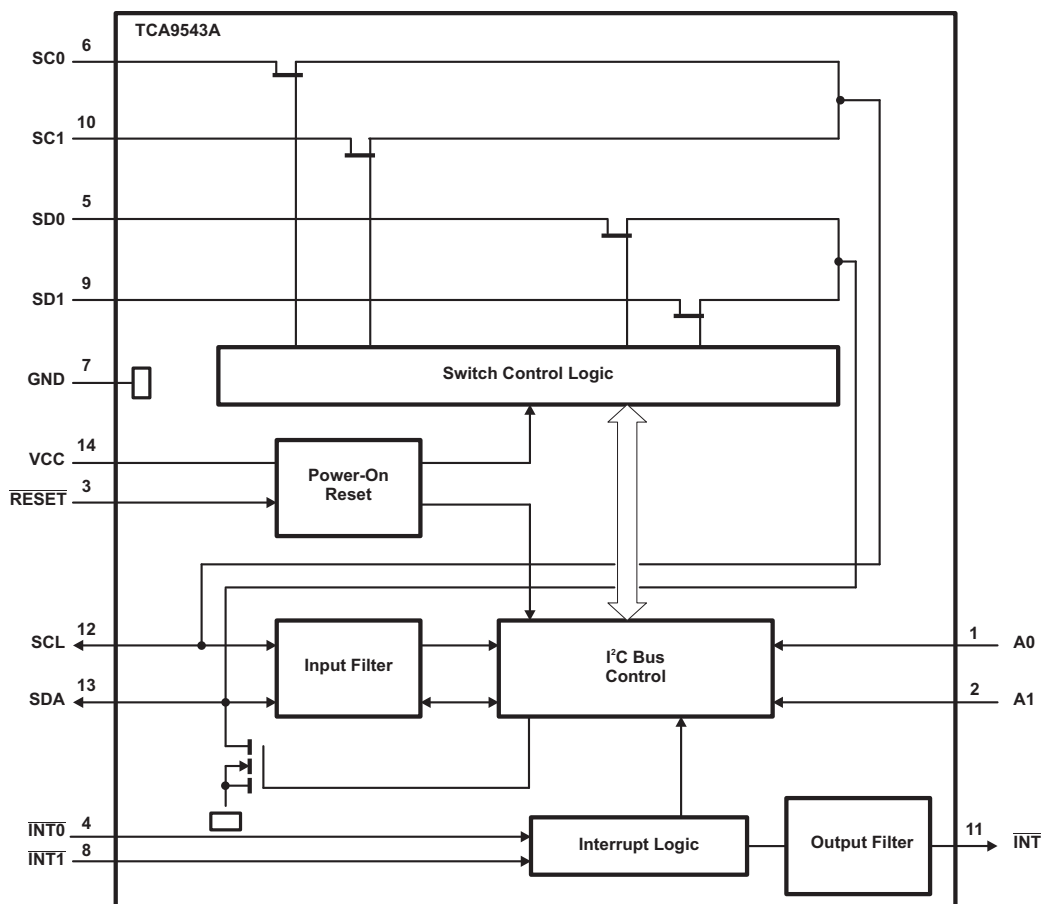

8.3 Feature Description

The TCA9543A is a dual channel bidirectional translating switch for I²C buses that supports Standard-Mode (100 kHz) and Fast-Mode (400 kHz) operation. The TCA9543A features I²C control using a single 8-bit control register in which bits 1 and 0 control the enabling and disabling of the two switch channels of I²C data flow. The TCA9543A also supports interrupt signals for each slave channel and this data is held in bits 5 and 4 of the control register. Depending on the application, voltage translation of the I²C bus can also be achieved using the TCA9543A to allow 1.8-V, 2.5-V, or 3.3-V parts to communicate with 5-V parts. Additionally, in the event that communication on the I²C bus enters a fault state, the TCA9543A can be reset to resume normal operation using the RESET terminal feature or by a power-on reset which results from cycling power to the device.

8.4 Device Functional Modes

8.4.1 RESET Input

The RESET input can be used to recover the TCA9543A from a bus-fault condition. The registers and the I²C state machine within this device initialize to their default states if this signal is asserted low for a minimum of t_{WL} . Both channels also are deselected in this case. RESET must be connected to V_{CC} through a pull-up resistor.

8.4.2 Power-On Reset

When power is applied to V_{CC}, an internal power-on reset holds the TCA9543A in a reset condition until V_{CC} has reached V_{PORR}. At this point, the reset condition is released and the TCA9543A registers and I²C state machine are initialized to their default states, all zeroes, causing all the channels to be deselected. Thereafter, V_{CC} must be lowered below V_{PORF} to reset the device.

8.5 Programming

8.5.1 I²C Interface

The I²C bus is for two-way, two-line communication between different ICs or modules. The two lines are a serial data line (SDA) and a serial clock line (SCL). Both lines must be connected to a positive supply via a pullup resistor when connected to the output stages of a device. Data transfer may be initiated only when the bus is not busy.

One data bit is transferred during each clock pulse. The data on the SDA line must remain stable during the high period of the clock pulse as changes in the data line at this time is interpreted as control signals (see Figure 8).

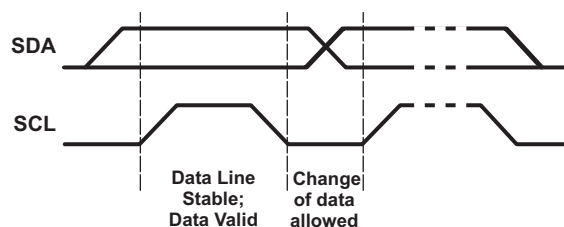

Figure 8. Bit Transfer

Both data and clock lines remain high when the bus is not busy. A high-to-low transition of the data line while the clock is high is defined as the start condition (S). A low-to-high transition of the data line while the clock is high is defined as the stop condition (P) (see Figure 9).

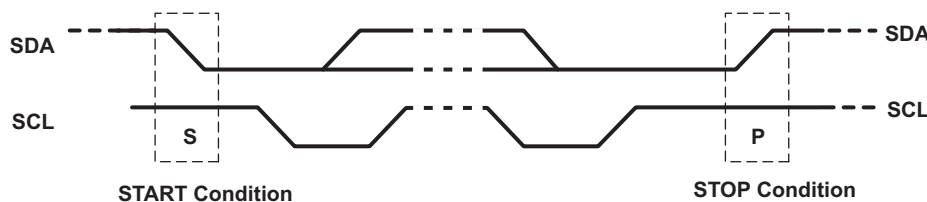

Figure 9. Definition of Start and Stop Conditions

Programming (continued)

A device generating a message is a transmitter; a device receiving a message is the receiver. The device that controls the message is the master and the devices that are controlled by the master are the slaves (see Figure 10).

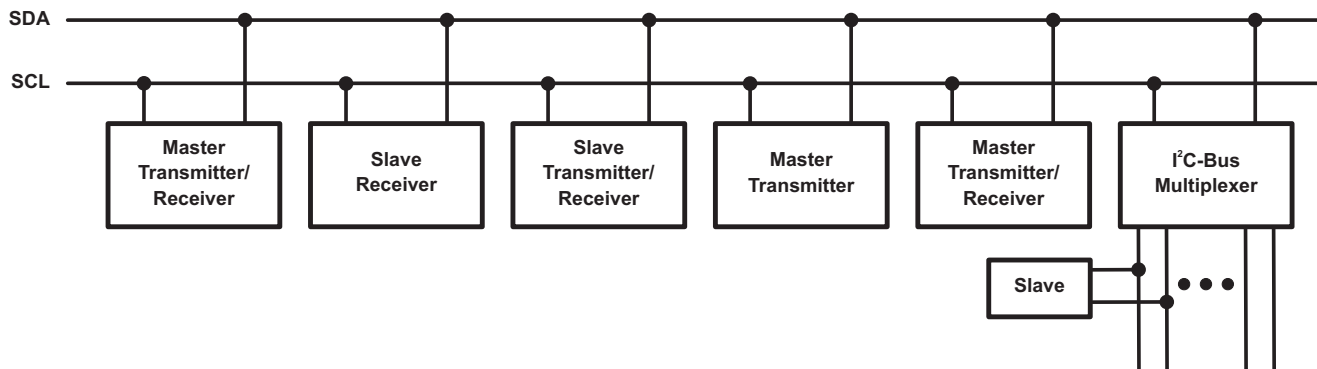

Figure 10. System Configuration

The number of data bytes transferred between the start and the stop conditions from transmitter to receiver is not limited. Each byte of eight bits is followed by one acknowledge (ACK) bit. The transmitter must release the SDA line before the receiver can send an ACK bit.

When a slave receiver is addressed, it must generate an ACK after the reception of each byte. Also, a master must generate an ACK after the reception of each byte that has been clocked out of the slave transmitter. The device that acknowledges must pull down the SDA line during the ACK clock pulse, so that the SDA line is stable low during the high pulse of the ACK-related clock period (see Figure 11). Setup and hold times must be taken into account.

A master receiver must signal an end of data to the transmitter by not generating an acknowledge (NACK) after the last byte has been clocked out of the slave. This is done by the master receiver by holding the SDA line high. In this event, the transmitter must release the data line to enable the master to generate a stop condition.

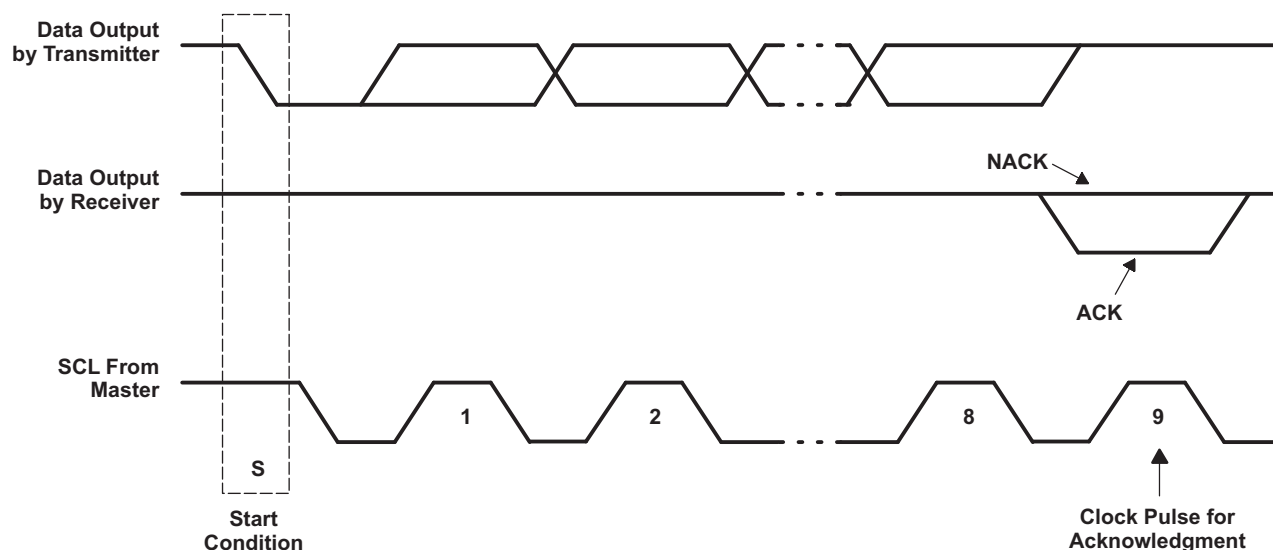

Figure 11. Acknowledgment on I²C Bus

Data is transmitted to the TCA9543A control register using the write mode shown in Figure 12.

Programming (continued)

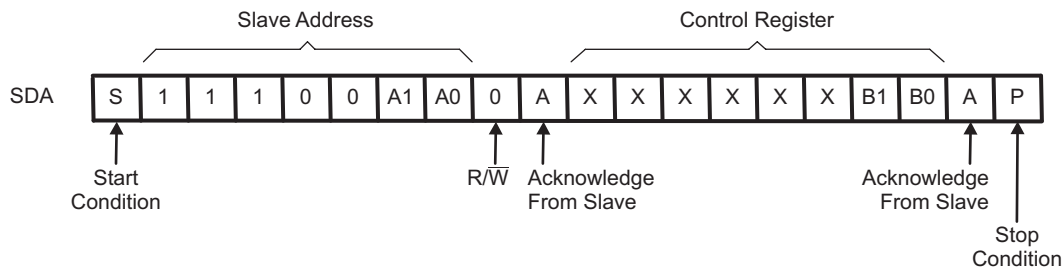

Figure 12. Write Control Register

Data is read from the TCA9543A control register using the read mode shown in [Figure 13](#).

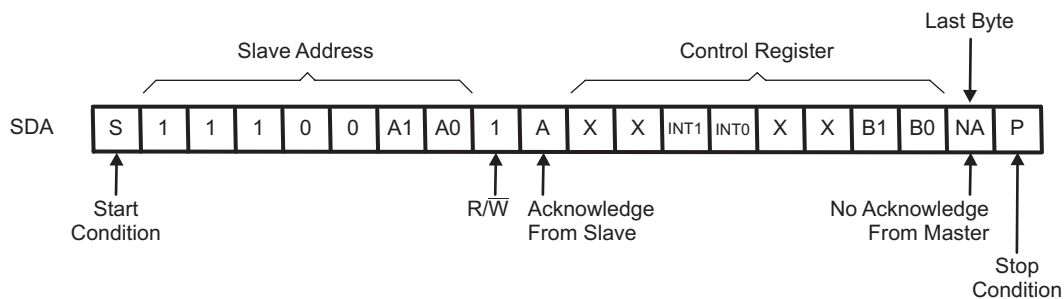

Figure 13. Read Control Register

8.6 Register Maps

8.6.1 Device Address

Following a start condition, the bus master must output the address of the slave it is accessing. The address of the TCA9543A is shown in [Figure 14](#). To conserve power, no internal pullup resistors are incorporated on the hardware-selectable address terminals and they must be pulled high or low.

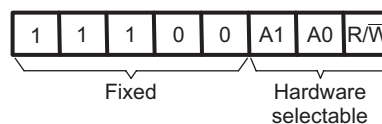

Figure 14. Slave Address TCA9543A

The last bit of the slave address defines the operation to be performed. When set to a logic 1, a read is selected, while a logic 0 selects a write operation.

8.6.2 Control Register Description

Following the successful acknowledgment of the slave address, the bus master sends a byte to the TCA9543A, which is stored in the control register (see [Figure 15](#)). If multiple bytes are received by the TCA9543A, it saves the last byte received. This register can be written and read via the I²C bus.

Register Maps (continued)

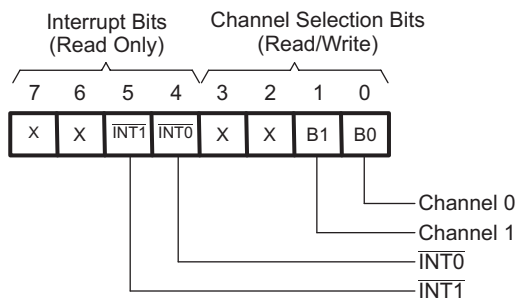

Figure 15. Control Register

8.6.3 Control Register Definition

One or both SCn/SDn downstream pairs, or channels, are selected by the contents of the control register (see Table 1). After the TCA9543A has been addressed, the control register is written. The two LSBs of the control byte are used to determine which channel or channels are to be selected. When a channel is selected, the channel becomes active after a stop condition has been placed on the I²C bus. This ensures that all SCn/SDn lines are in a high state when the channel is made active, so that no false conditions are generated at the time of connection. A stop condition must occur always right after the acknowledge cycle.

Table 1. Control Register Write (Channel Selection), Control Register Read (Channel Status)⁽¹⁾

D7	D6	$\overline{\text{INT1}}$	$\overline{\text{INT0}}$	D3	D2	B1	B0	COMMAND
X	X	X	X	X	X	X	0	Channel 0 disabled
							1	Channel 0 enabled
X	X	X	X	X	X	0	X	Channel 1 disabled
						1		Channel 1 enabled
0	0	0	0	0	0	0	0	No channel selected; power-up/reset default state

(1) Channel 0 and channel 1 can be enabled at the same time. Care should be taken not to exceed the maximum bus capacitance.

8.6.4 Interrupt Handling

The TCA9543A provides two interrupt inputs (one for each channel) and one open-drain interrupt output (see Table 2). When an interrupt is generated by any device, it is detected by the TCA9543A and the interrupt output is driven low. The channel does not need to be active for detection of the interrupt. A bit also is set in the control register.

Bit 4 and Bit 5 of the control register correspond to the $\overline{\text{INT0}}$ and $\overline{\text{INT1}}$ inputs of the TCA9543A, respectively. Therefore, if an interrupt is generated by any device connected to channel 1, the state of the interrupt inputs is loaded into the control register when a read is accomplished. Likewise, an interrupt on any device connected to channel 0 would cause bit 4 of the control register to be set on the read. The master then can address the TCA9543A and read the contents of the control register to determine which channel contains the device generating the interrupt. The master then can reconfigure the TCA9543A to select this channel, and locate the device generating the interrupt and clear it.

It should be noted that more than one device can provide an interrupt on a channel, so it is up to the master to ensure that all devices on a channel are interrogated for an interrupt.

The interrupt inputs may be used as general-purpose inputs if the interrupt function is not required.

If unused, interrupt input(s) must be connected to V_{CC} through a pull-up resistor.

Table 2. Control Register Read (Interrupt)⁽¹⁾

D7	D6	$\overline{\text{INT1}}$	$\overline{\text{INT0}}$	D3	D2	B1	B0	COMMAND
X	X	X	0	X	X	X	X	No interrupt on channel 0
			1					Interrupt on channel 0
X	X	0	X	X	X	X	X	No interrupt on channel 1
		1						Interrupt on channel 1
0	0	0	0	0	0	0	0	No channel selected; power-up/reset default state

(1) Two interrupts can be active at the same time.

9 Application and Implementation

NOTE

Information in the following applications sections is not part of the TI component specification, and TI does not warrant its accuracy or completeness. TI's customers are responsible for determining suitability of components for their purposes. Customers should validate and test their design implementation to confirm system functionality.

9.1 Application Information

Applications of the TCA9543A will contain an I²C (or SMBus) master device and up to two I²C slave devices. The downstream channels are ideally used to resolve I²C slave address conflicts. For example, if two identical digital temperature sensors are needed in the application, one sensor can be connected at each channel: 0 and 1. When the temperature at a specific location needs to be read, the appropriate channel can be enabled and the other channel switched off, the data can be retrieved, and the I²C master can move on and read the next channel.

In an application where the I²C bus will contain many additional slave devices that do not result in I²C slave address conflicts, these slave devices can be connected to any desired channel to distribute the total bus capacitance across both channels. If both switches will be enabled simultaneously, additional design requirements must be considered (See [Design Requirements](#) and [Detailed Design Procedure](#)).

9.2 Typical Application

A typical application of the TCA9543A contains anywhere from 1 to 3 separate data pull-up voltages, V_{DPUX} , one for the master device (V_{DPUM}) and one for each of the selectable slave channels (V_{DPU0} and V_{DPU1}). In the event where the master device and both slave devices operate at the same voltage, then the pass voltage, $V_{PASS} = V_{DPUX}$. Once the maximum V_{PASS} is known, V_{CC} can be selected easily using [Figure 17](#). In an application where voltage translation is necessary, additional design requirements must be considered (See [Design Requirements](#)).

[Figure 16](#) shows an application in which the TCA9543A can be used.

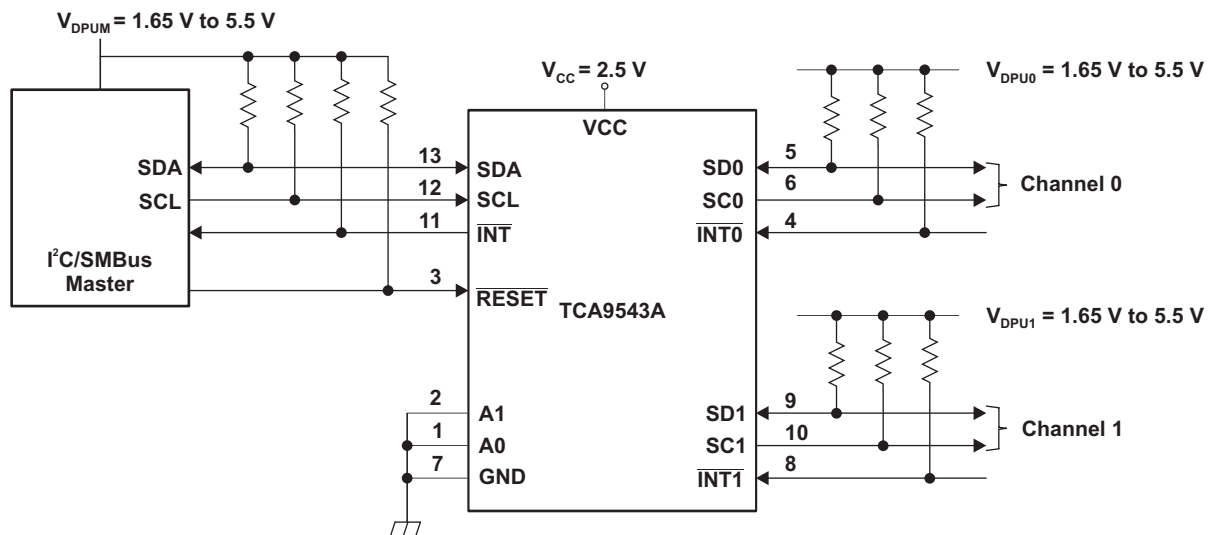

Figure 16. Typical Application Schematic

9.2.1 Design Requirements

The pull-up resistors on the $\overline{INT1}$ - $\overline{INT0}$ terminals in the application schematic are not required in all applications. If the device generating the interrupt has an open-drain output structure or can be tri-stated, a pull-up resistor is required. If the device generating the interrupt has a push-pull output structure and cannot be tri-stated, a pull-up resistor is not required. The interrupt inputs should not be left floating in the application.

Typical Application (continued)

The A0 and A1 terminals are hardware selectable to control the slave address of the TCA9543A. These terminals may be tied directly to GND or V_{CC} in the application.

If both slave channels will be activated simultaneously in the application, then the total I_{OL} from SCL/SDA to GND on the master side will be the sum of the currents through all pull-up resistors, R_p .

The pass-gate transistors of the TCA9543A are constructed such that the V_{CC} voltage can be used to limit the maximum voltage that is passed from one I²C bus to another.

Figure 17 shows the voltage characteristics of the pass-gate transistors (note that the graph was generated using data specified in the [Electrical Characteristics](#) section of this data sheet). In order for the TCA9543A to act as a voltage translator, the V_{pass} voltage must be equal to or lower than the lowest bus voltage. For example, if the main bus is running at 5 V and the downstream buses are 3.3 V and 2.7 V, V_{pass} must be equal to or below 2.7 V to effectively clamp the downstream bus voltages. As shown in Figure 17, $V_{pass(max)}$ is 2.7 V when the TCA9543A supply voltage is 4 V or lower, so the TCA9543A supply voltage could be set to 3.3 V. Pull-up resistors then can be used to bring the bus voltages to their appropriate levels (see Figure 16).

9.2.2 Detailed Design Procedure

Once all the slaves are assigned to the appropriate slave channels and bus voltages are identified, the pull-up resistors, R_p , for each of the buses need to be selected appropriately. The minimum pull-up resistance is a function of V_{DPUX} , $V_{OL(max)}$, and I_{OL} :

$$R_{p(min)} = \frac{V_{DPUX} - V_{OL(max)}}{I_{OL}} \quad (1)$$

The maximum pull-up resistance is a function of the maximum rise time, t_r (300 ns for fast-mode operation, $f_{SCL} = 400$ kHz) and bus capacitance, C_b :

$$R_{p(max)} = \frac{t_r}{0.8473 \times C_b} \quad (2)$$

The maximum bus capacitance for an I²C bus must not exceed 400 pF for fast-mode operation. The bus capacitance can be approximated by adding the capacitance of the TCA9543A, $C_{io(OFF)}$, the capacitance of wires/connections/traces, and the capacitance of each individual slave on a given channel. If both channels will be activated simultaneously, each of the slaves on both channels will contribute to total bus capacitance.

Typical Application (continued)

9.2.3 Application Curves

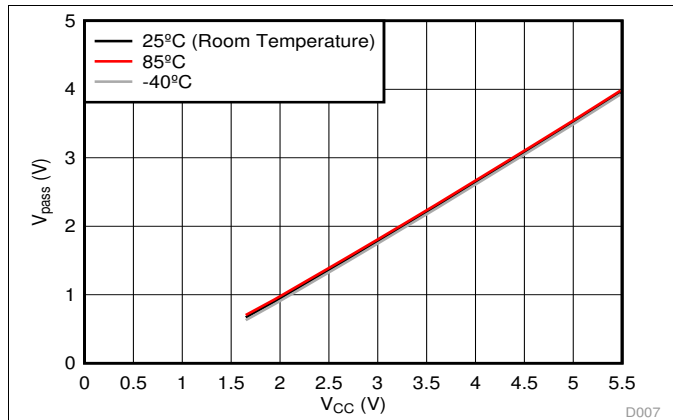
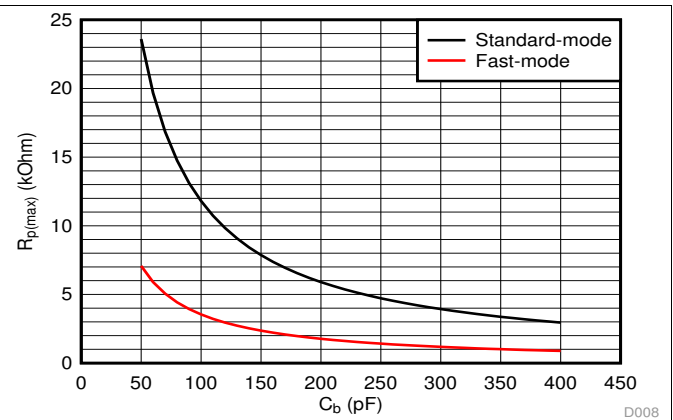
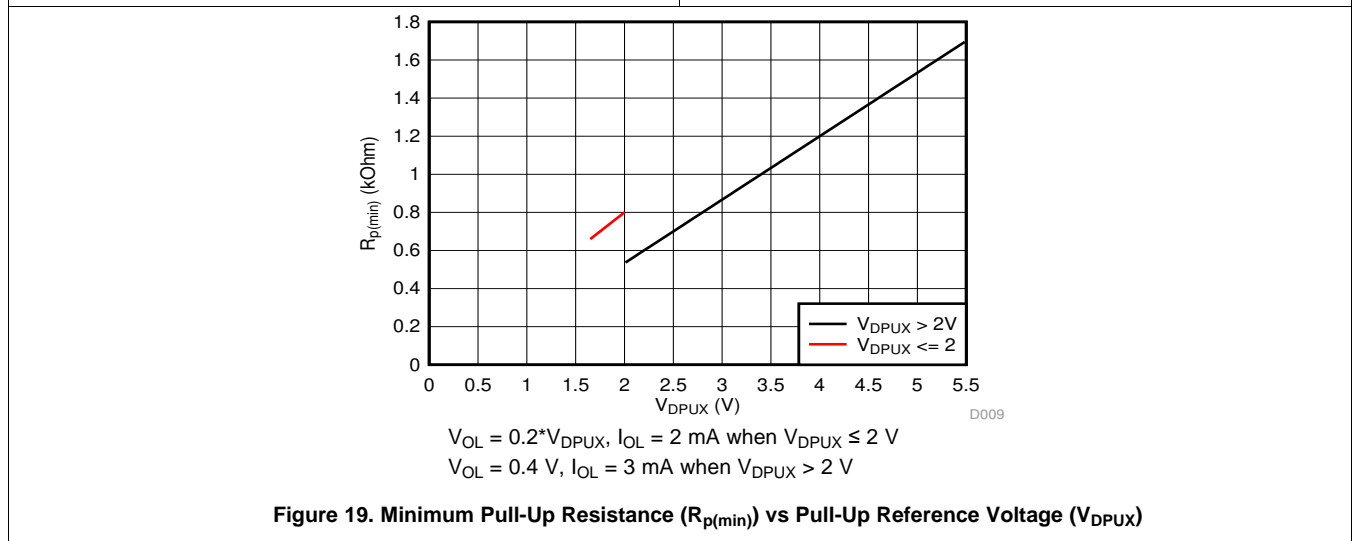

Figure 17. Pass-Gate Voltage (V_{pass}) vs Supply Voltage (V_{CC}) at Three Temperature Points



Standard-mode (f_{SCL} = 100 kHz, t_r = 1 μs) Fast-mode (f_{SCL} = 400 kHz, t_r = 300 ns)

Figure 18. Maximum Pull-Up Resistance (R_{p(max)}) vs Bus Capacitance (C_b)



V_{OL} = 0.2 * V_{DPUX}, I_{OL} = 2 mA when V_{DPUX} ≤ 2 V
 V_{OL} = 0.4 V, I_{OL} = 3 mA when V_{DPUX} > 2 V

Figure 19. Minimum Pull-Up Resistance (R_{p(min)}) vs Pull-Up Reference Voltage (V_{DPUX})

10 Power Supply Recommendations

The operating power-supply voltage range of the TCA9543A is 1.65-V to 5.5-V applied at the VCC terminal. When the TCA9543A is powered on for the first time or anytime the device needs to be reset by cycling the power supply, the power-on reset requirements must be followed to ensure the I²C bus logic is initialized properly.

10.1 Power-On Reset Requirements

In the event of a glitch or data corruption, TCA9543A can be reset to its default conditions by using the power-on reset feature. Power-on reset requires that the device go through a power cycle to be completely reset. This reset also happens when the device is powered on for the first time in an application.

A power-on reset is shown in Figure 20.

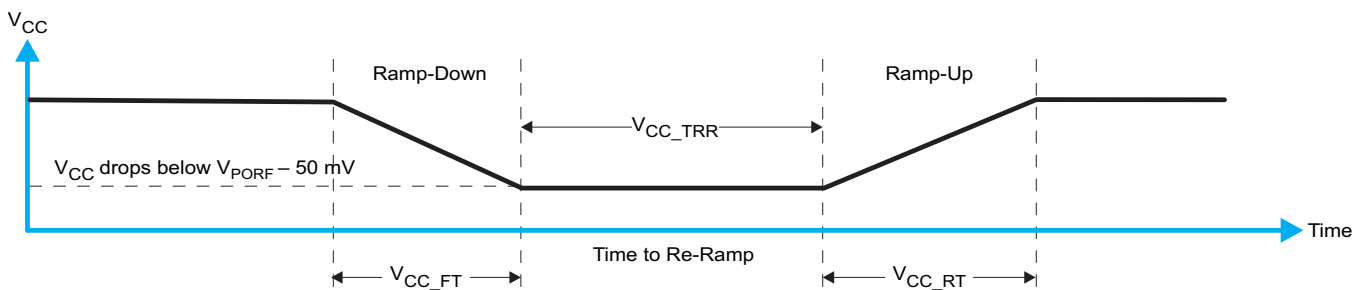

Figure 20. V_{CC} is Lowered Below the POR Threshold, Then Ramped Back Up to V_{CC}

Table 3 specifies the performance of the power-on reset feature for TCA9543A for both types of power-on reset.

Table 3. Recommended Supply Sequencing And Ramp Rates⁽¹⁾

PARAMETER		MIN	TYP	MAX	UNIT
V _{CC_FT}	Fall time	See Figure 20	1	100	ms
V _{CC_RT}	Rise time	See Figure 20	0.1	100	ms
V _{CC_TRR}	Time to re-ramp (when V _{CC} drops below V _{PORF(min)} – 50 mV or when V _{CC} drops to GND)	See Figure 20	40		μs
V _{CC_GH}	Level that V _{CC} can glitch down to, but not cause a functional disruption when V _{CC_GW} = 1 μs	See Figure 21		1.2	V
V _{CC_GW}	Glitch width that will not cause a functional disruption when V _{CC_GH} = 0.5 × V _{CC}	See Figure 21		10	μs
V _{PORF}	Voltage trip point of POR on falling V _{CC}	See Figure 22	0.8	1.25	V
V _{PORR}	Voltage trip point of POR on rising V _{CC}	See Figure 22	1.05	1.5	V

(1) All supply sequencing and ramp rate values are measured at T_A = 25°C

Glitches in the power supply can also affect the power-on reset performance of this device. The glitch width (V_{CC_GW}) and height (V_{CC_GH}) are dependent on each other. The bypass capacitance, source impedance, and device impedance are factors that affect power-on reset performance. Figure 21 and Table 3 provide more information on how to measure these specifications.

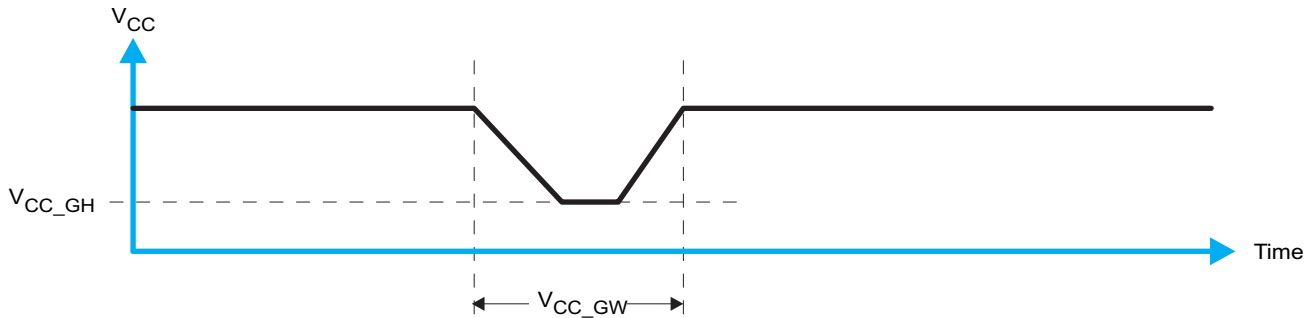

Figure 21. Glitch Width and Glitch Height

V_{POR} is critical to the power-on reset. V_{POR} is the voltage level at which the reset condition is released and all the registers and the I²C/SMBus state machine are initialized to their default states. The value of V_{POR} differs based on the V_{CC} being lowered to or from 0. Figure 22 and Table 3 provide more details on this specification.

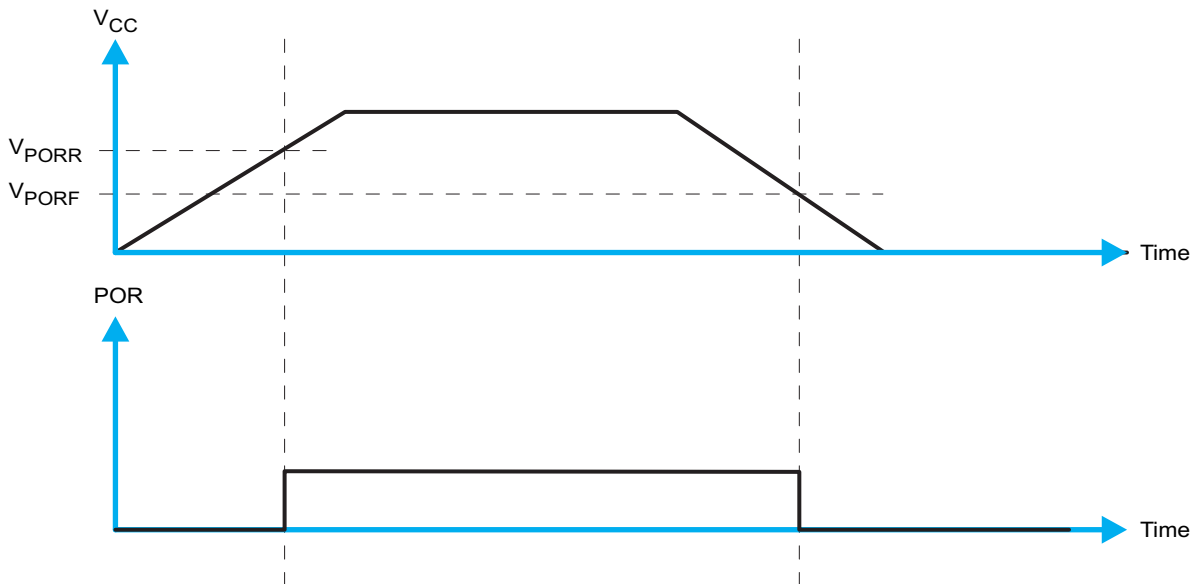

Figure 22. V_{POR}

11 Layout

11.1 Layout Guidelines

For PCB layout of the TCA9543A, common PCB layout practices should be followed but additional concerns related to high-speed data transfer such as matched impedances and differential pairs are not a concern for I²C signal speeds. It is common to have a dedicated ground plane on an inner layer of the board and terminals that are connected to ground should have a low-impedance path to the ground plane in the form of wide polygon pours and multiple vias. By-pass and de-coupling capacitors are commonly used to control the voltage on the VCC terminal, using a larger capacitor to provide additional power in the event of a short power supply glitch and a smaller capacitor to filter out high-frequency ripple.

In an application where voltage translation is not required, all V_{DPUX} voltages and V_{CC} could be at the same potential and a single copper plane can connect all of the pull-up resistors to the appropriate reference voltage. In an application where voltage translation is required, V_{DPUM} , V_{DPU0} , and V_{DPU1} , may all be on the same layer of the board with split planes to isolate different voltage potentials.

To reduce the total I²C bus capacitance added by PCB parasitics, data lines (SCn, SDn and \overline{INTn}) should be as short as possible and the widths of the traces should also be minimized (e.g. 5-10 mils depending on copper weight).

11.2 Layout Example

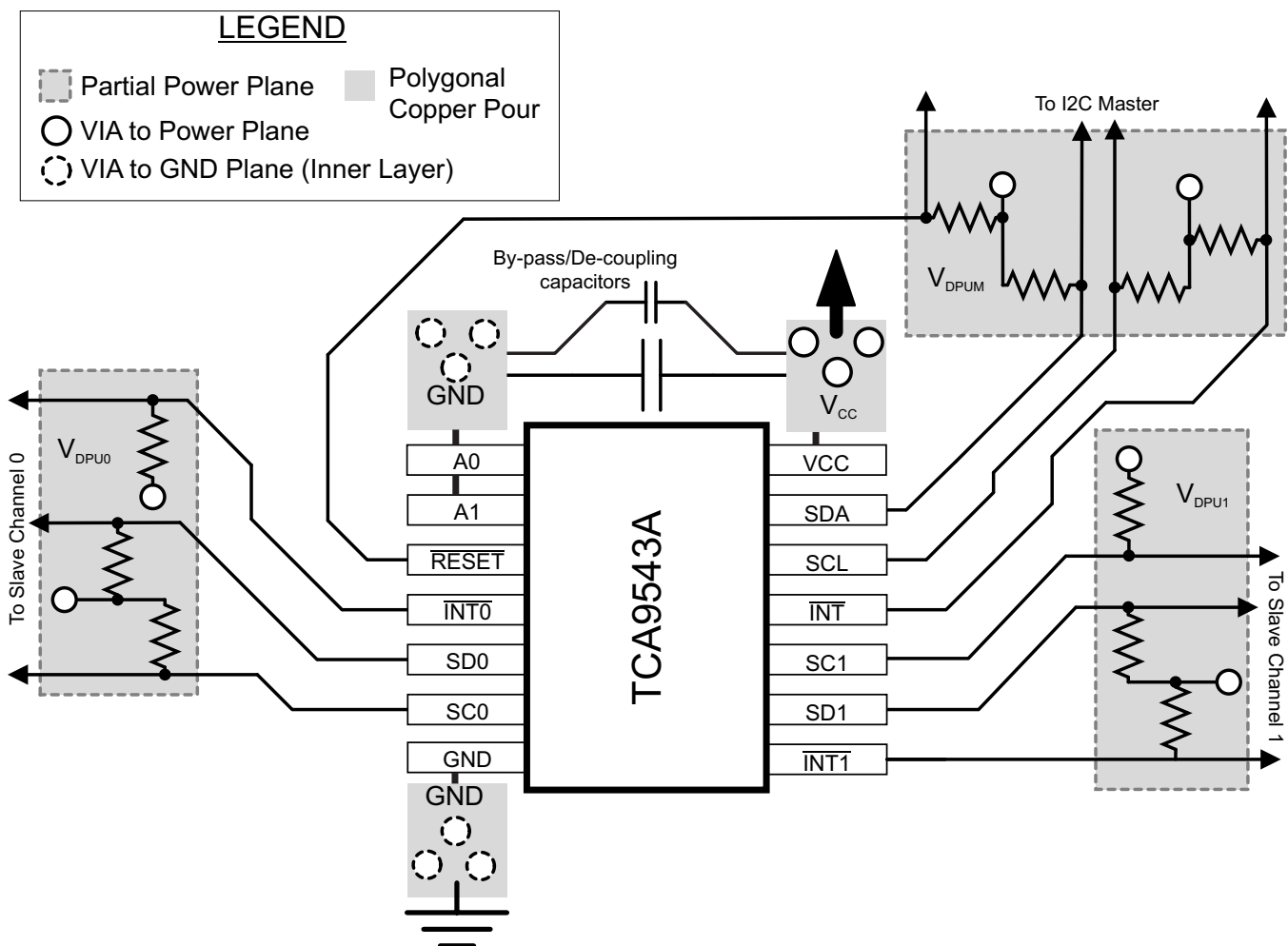

Figure 23. Layout Example

12 器件和文档支持

12.1 接收文档更新通知

要接收文档更新通知，请导航至 [Ti.com.cn](http://ti.com.cn) 上的器件产品文件夹。单击右上角的通知我进行注册，即可每周接收产品信息更改摘要。有关更改的详细信息，请查看任何已修订文档中包含的修订历史记录。

12.2 支持资源

[TI E2E™ support forums](#) are an engineer's go-to source for fast, verified answers and design help — straight from the experts. Search existing answers or ask your own question to get the quick design help you need.

Linked content is provided "AS IS" by the respective contributors. They do not constitute TI specifications and do not necessarily reflect TI's views; see TI's [Terms of Use](#).

12.3 商标

E2E is a trademark of Texas Instruments.

All other trademarks are the property of their respective owners.

12.4 静电放电警告



ESD 可能会损坏该集成电路。德州仪器 (TI) 建议通过适当的预防措施处理所有集成电路。如果不遵守正确的处理措施和安装程序，可能会损坏集成电路。

ESD 的损坏小至导致微小的性能降级，大至整个器件故障。精密的集成电路可能更容易受到损坏，这是因为非常细微的参数更改都可能会导致器件与其发布的规格不相符。

12.5 Glossary

[SLYZ022](#) — *TI Glossary*.

This glossary lists and explains terms, acronyms, and definitions.

13 机械、封装和可订购信息

以下页面包含机械、封装和可订购信息。这些信息是指定器件的最新可用数据。数据如有变更，恕不另行通知，且不会对此文档进行修订。如需获取此数据表的浏览器版本，请查阅左侧的导航栏。

PACKAGING INFORMATION

Orderable part number	Status (1)	Material type (2)	Package Pins	Package qty Carrier	RoHS (3)	Lead finish/ Ball material (4)	MSL rating/ Peak reflow (5)	Op temp (°C)	Part marking (6)
TCA9543ADR	Active	Production	SOIC (D) 14	2500 LARGE T&R	Yes	NIPDAU	Level-1-260C-UNLIM	-40 to 85	TCA9543A
TCA9543ADR.B	Active	Production	SOIC (D) 14	2500 LARGE T&R	Yes	NIPDAU	Level-1-260C-UNLIM	-40 to 85	TCA9543A
TCA9543ADRG4	Active	Production	SOIC (D) 14	2500 LARGE T&R	Yes	NIPDAU	Level-1-260C-UNLIM	-40 to 85	TCA9543A
TCA9543ADRG4.B	Active	Production	SOIC (D) 14	2500 LARGE T&R	Yes	NIPDAU	Level-1-260C-UNLIM	-40 to 85	TCA9543A
TCA9543APWR	Active	Production	TSSOP (PW) 14	2000 LARGE T&R	Yes	NIPDAU SN	Level-1-260C-UNLIM	-40 to 85	PW543A
TCA9543APWR.B	Active	Production	TSSOP (PW) 14	2000 LARGE T&R	Yes	NIPDAU	Level-1-260C-UNLIM	-40 to 85	PW543A
TCA9543APWRG4	Active	Production	TSSOP (PW) 14	2000 LARGE T&R	Yes	NIPDAU	Level-1-260C-UNLIM	-40 to 85	PW543A
TCA9543APWRG4.B	Active	Production	TSSOP (PW) 14	2000 LARGE T&R	Yes	NIPDAU	Level-1-260C-UNLIM	-40 to 85	PW543A

(1) **Status:** For more details on status, see our [product life cycle](#).

(2) **Material type:** When designated, preproduction parts are prototypes/experimental devices, and are not yet approved or released for full production. Testing and final process, including without limitation quality assurance, reliability performance testing, and/or process qualification, may not yet be complete, and this item is subject to further changes or possible discontinuation. If available for ordering, purchases will be subject to an additional waiver at checkout, and are intended for early internal evaluation purposes only. These items are sold without warranties of any kind.

(3) **RoHS values:** Yes, No, RoHS Exempt. See the [TI RoHS Statement](#) for additional information and value definition.

(4) **Lead finish/Ball material:** Parts may have multiple material finish options. Finish options are separated by a vertical ruled line. Lead finish/Ball material values may wrap to two lines if the finish value exceeds the maximum column width.

(5) **MSL rating/Peak reflow:** The moisture sensitivity level ratings and peak solder (reflow) temperatures. In the event that a part has multiple moisture sensitivity ratings, only the lowest level per JEDEC standards is shown. Refer to the shipping label for the actual reflow temperature that will be used to mount the part to the printed circuit board.

(6) **Part marking:** There may be an additional marking, which relates to the logo, the lot trace code information, or the environmental category of the part.

Multiple part markings will be inside parentheses. Only one part marking contained in parentheses and separated by a "-" will appear on a part. If a line is indented then it is a continuation of the previous line and the two combined represent the entire part marking for that device.

Important Information and Disclaimer:The information provided on this page represents TI's knowledge and belief as of the date that it is provided. TI bases its knowledge and belief on information provided by third parties, and makes no representation or warranty as to the accuracy of such information. Efforts are underway to better integrate information from third parties. TI has taken and continues to take reasonable steps to provide representative and accurate information but may not have conducted destructive testing or chemical analysis on incoming materials and chemicals. TI and TI suppliers consider certain information to be proprietary, and thus CAS numbers and other limited information may not be available for release.

In no event shall TI's liability arising out of such information exceed the total purchase price of the TI part(s) at issue in this document sold by TI to Customer on an annual basis.

TAPE AND REEL INFORMATION

QUADRANT ASSIGNMENTS FOR PIN 1 ORIENTATION IN TAPE

*All dimensions are nominal

Device	Package Type	Package Drawing	Pins	SPQ	Reel Diameter (mm)	Reel Width W1 (mm)	A0 (mm)	B0 (mm)	K0 (mm)	P1 (mm)	W (mm)	Pin1 Quadrant
TCA9543ADR	SOIC	D	14	2500	330.0	16.4	6.5	9.0	2.1	8.0	16.0	Q1
TCA9543ADRG4	SOIC	D	14	2500	330.0	16.4	6.5	9.0	2.1	8.0	16.0	Q1
TCA9543APWR	TSSOP	PW	14	2000	330.0	12.4	6.9	5.6	1.6	8.0	12.0	Q1
TCA9543APWR	TSSOP	PW	14	2000	330.0	12.4	6.9	5.6	1.6	8.0	12.0	Q1
TCA9543APWRG4	TSSOP	PW	14	2000	330.0	12.4	6.9	5.6	1.6	8.0	12.0	Q1

TAPE AND REEL BOX DIMENSIONS



*All dimensions are nominal

Device	Package Type	Package Drawing	Pins	SPQ	Length (mm)	Width (mm)	Height (mm)
TCA9543ADR	SOIC	D	14	2500	353.0	353.0	32.0
TCA9543ADRG4	SOIC	D	14	2500	353.0	353.0	32.0
TCA9543APWR	TSSOP	PW	14	2000	353.0	353.0	32.0
TCA9543APWR	TSSOP	PW	14	2000	356.0	356.0	35.0
TCA9543APWRG4	TSSOP	PW	14	2000	353.0	353.0	32.0

D0014A



PACKAGE OUTLINE

SOIC - 1.75 mm max height

SMALL OUTLINE INTEGRATED CIRCUIT

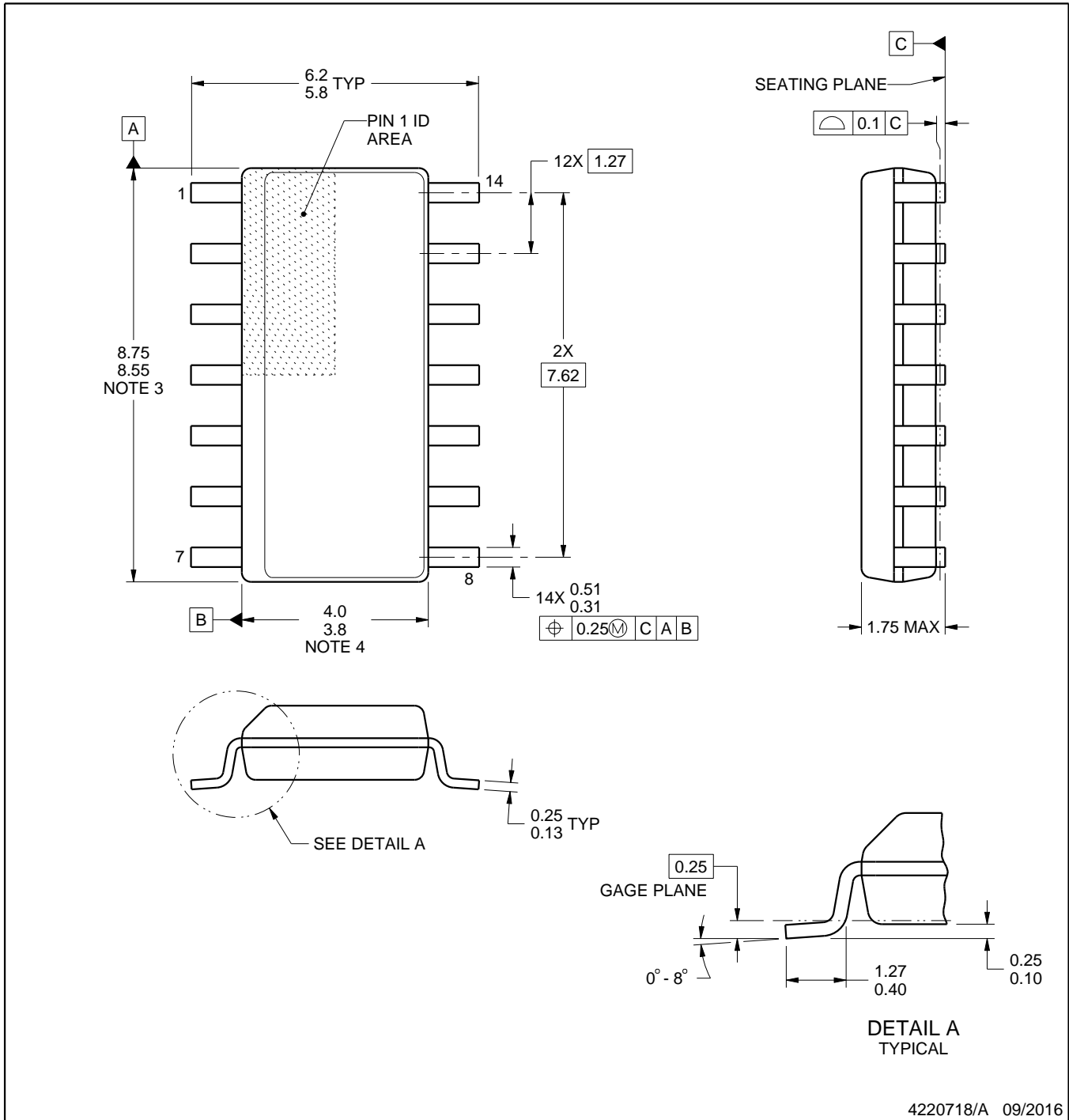

NOTES:

1. All linear dimensions are in millimeters. Dimensions in parenthesis are for reference only. Dimensioning and tolerancing per ASME Y14.5M.
2. This drawing is subject to change without notice.
3. This dimension does not include mold flash, protrusions, or gate burrs. Mold flash, protrusions, or gate burrs shall not exceed 0.15 mm, per side.
4. This dimension does not include interlead flash. Interlead flash shall not exceed 0.43 mm, per side.
5. Reference JEDEC registration MS-012, variation AB.

EXAMPLE BOARD LAYOUT

D0014A

SOIC - 1.75 mm max height

SMALL OUTLINE INTEGRATED CIRCUIT



LAND PATTERN EXAMPLE
SCALE:8X



SOLDER MASK DETAILS

4220718/A 09/2016

NOTES: (continued)

- 6. Publication IPC-7351 may have alternate designs.
- 7. Solder mask tolerances between and around signal pads can vary based on board fabrication site.

EXAMPLE BOARD LAYOUT

PW0014A

TSSOP - 1.2 mm max height

SMALL OUTLINE PACKAGE

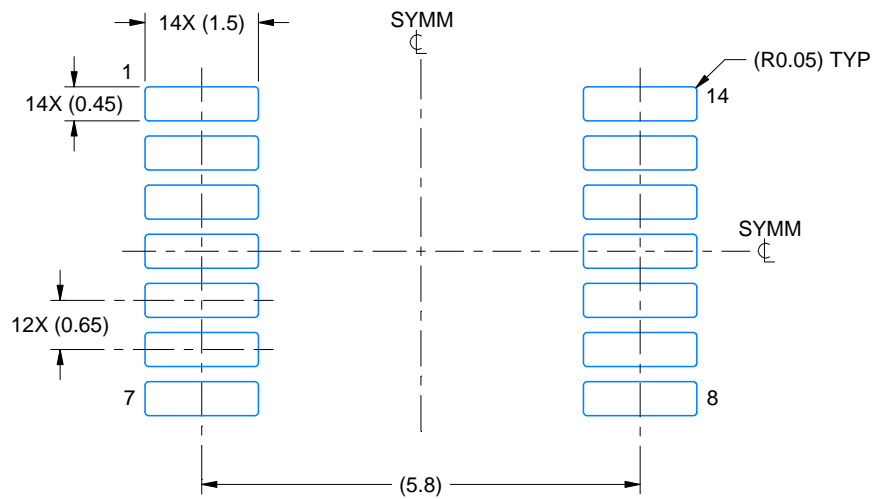

LAND PATTERN EXAMPLE
EXPOSED METAL SHOWN
SCALE: 10X

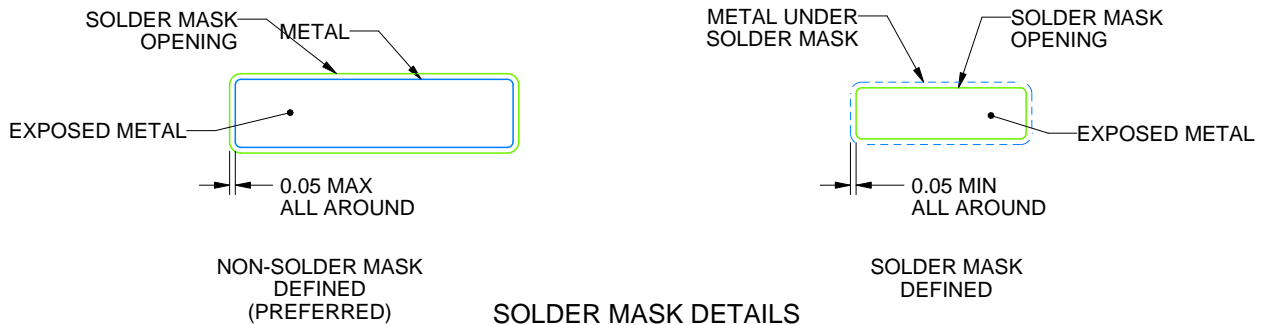

4220202/B 12/2023

NOTES: (continued)

- 6. Publication IPC-7351 may have alternate designs.
- 7. Solder mask tolerances between and around signal pads can vary based on board fabrication site.

EXAMPLE STENCIL DESIGN

PW0014A

TSSOP - 1.2 mm max height

SMALL OUTLINE PACKAGE

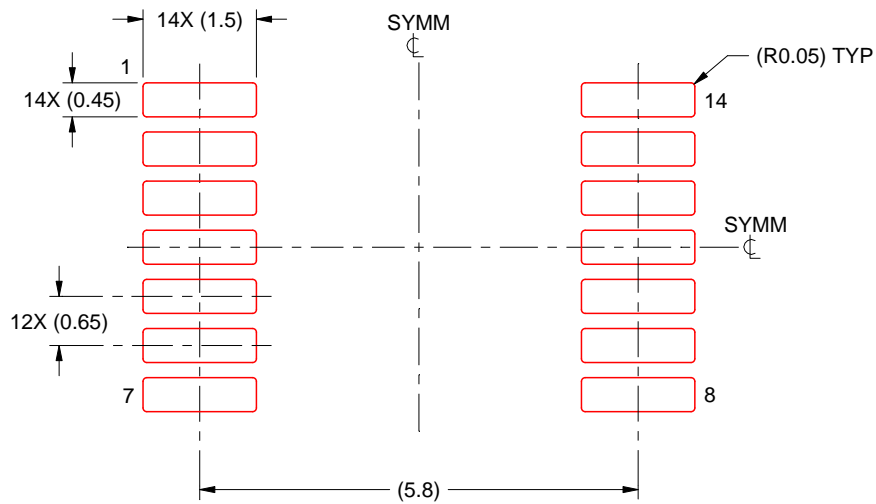

SOLDER PASTE EXAMPLE
BASED ON 0.125 mm THICK STENCIL
SCALE: 10X

4220202/B 12/2023

NOTES: (continued)

8. Laser cutting apertures with trapezoidal walls and rounded corners may offer better paste release. IPC-7525 may have alternate design recommendations.
9. Board assembly site may have different recommendations for stencil design.

重要通知和免责声明

TI“按原样”提供技术和可靠性数据（包括数据表）、设计资源（包括参考设计）、应用或其他设计建议、网络工具、安全信息和其他资源，不保证没有瑕疵且不做任何明示或暗示的担保，包括但不限于对适销性、与某特定用途的适用性或不侵犯任何第三方知识产权的暗示担保。

这些资源可供使用 TI 产品进行设计的熟练开发人员使用。您将自行承担以下全部责任：(1) 针对您的应用选择合适的 TI 产品，(2) 设计、验证并测试您的应用，(3) 确保您的应用满足相应标准以及任何其他安全、安保法规或其他要求。

这些资源如有变更，恕不另行通知。TI 授权您仅可将这些资源用于研发本资源所述的 TI 产品的相关应用。严禁以其他方式对这些资源进行复制或展示。您无权使用任何其他 TI 知识产权或任何第三方知识产权。对于因您对这些资源的使用而对 TI 及其代表造成的任何索赔、损害、成本、损失和债务，您将全额赔偿，TI 对此概不负责。

TI 提供的产品受 [TI 销售条款](#)、[TI 通用质量指南](#) 或 [ti.com](#) 上其他适用条款或 TI 产品随附的其他适用条款的约束。TI 提供这些资源并不会扩展或以其他方式更改 TI 针对 TI 产品发布的适用的担保或担保免责声明。除非德州仪器 (TI) 明确将某产品指定为定制产品或客户特定产品，否则其产品均为按确定价格收入目录的标准通用器件。

TI 反对并拒绝您可能提出的任何其他或不同的条款。

版权所有 © 2026，德州仪器 (TI) 公司

最后更新日期：2025 年 10 月