

## TL7702B、TL7733B 和 TL7705B 电源电压监控器

### 1 特性

- 上电复位发生器
- 电压下降后自动复位生成
- **RESET** 输出定义为从  $V_{CC} \geq 1V$  开始
- 精密电压传感器
- 温度补偿电压基准
- 真实和互补复位输出
- 外部可调脉冲持续时间

### 2 应用

- 无线通信系统
- 工厂自动化
- 楼宇自动化
- 服务器
- 笔记本电脑和台式机
- STB 和 DVR

### 3 说明

TL7702B、TL7705B 和 TL7733B 为集成电路电源电压监控器，旨在用作微型计算机和微处理器系统中的复位控制器。电源电压监控器监控 **SENSE** 输入端的电源是否欠压。正常运行期间，如果发生欠压，则输出 **RESET**，且 **RESET** 激活。

TL7702BC、TL7705BC 和 TL7733BC 的工作温度范围为  $0^{\circ}\text{C}$  至  $+70^{\circ}\text{C}$ 。TL7702BI、TL7705BI 和 TL7733BI 的工作温度范围为  $-40^{\circ}\text{C}$  至  $+85^{\circ}\text{C}$ 。TL7705BQ 的工作温度范围为  $-40^{\circ}\text{C}$  至  $+125^{\circ}\text{C}$ 。

#### 器件信息(1)

器件型号	封装	封装尺寸 (标称值)
TL77xxBD	SOIC (8)	4.90mm × 3.91mm
TL77xxBP	PDIP (8)	9.81mm × 6.35mm

(1) 如需了解所有可用封装，请参阅数据表末尾的可订购产品附录。

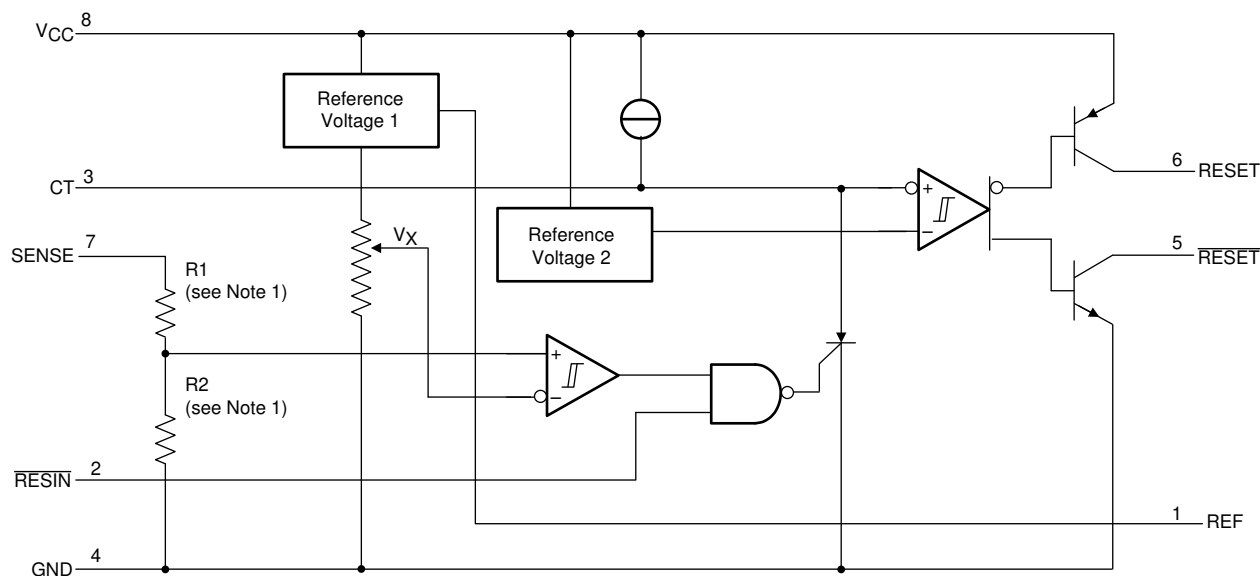

Copyright © 2016, Texas Instruments Incorporated

功能方框图



## Table of Contents

<b>1 特性</b> .....	1	8.2 Functional Block Diagram.....	10
<b>2 应用</b> .....	1	8.3 Feature Description.....	11
<b>3 说明</b> .....	1	8.4 Device Functional Modes.....	11
<b>4 Revision History</b> .....	2	<b>9 Application and Implementation</b> .....	12
<b>5 Pin Configuration and Functions</b> .....	3	9.1 Application Information.....	12
Pin Functions.....	3	9.2 Typical Application.....	12
<b>6 Specifications</b> .....	4	<b>10 Power Supply Recommendations</b> .....	14
6.1 Absolute Maximum Ratings.....	4	<b>11 Layout</b> .....	15
6.2 ESD Ratings.....	4	11.1 Layout Guidelines.....	15
6.3 Recommended Operating Conditions.....	4	11.2 Layout Example.....	15
6.4 Thermal Information.....	5	<b>12 Device and Documentation Support</b> .....	16
6.5 Electrical Characteristics: TL77xxBC, TL77xxBI, and TL7705BQ.....	6	12.1 Related Links.....	16
6.6 Switching Characteristics: TL77xxBC, TL77xxBI, and TL7705BQ.....	6	12.2 接收文档更新通知.....	16
6.7 Timing Diagrams.....	7	12.3 支持资源.....	16
6.8 Typical Characteristics.....	8	12.4 Trademarks.....	16
<b>7 Parameter Measurement Information</b> .....	9	12.5 静电放电警告.....	16
<b>8 Detailed Description</b> .....	10	12.6 术语表.....	16
8.1 Overview.....	10	<b>13 Mechanical, Packaging, and Orderable Information</b> .....	16

## 4 Revision History

### Changes from Revision N (September 2016) to Revision O (December 2020)

Page

- 更新了整个文档中的表格、图和交叉参考的编号格式..... 1
- Corrected the RESIN pin description..... 3
- Corrected the I<sub>CC</sub> parameter units from  $\mu$ A to mA in Electrical Characteristics Table..... 6

### Changes from Revision M (May 2003) to Revision N (September 2016)

Page

- 添加了 ESD 等级表、特性说明部分、器件功能模式、应用和实施部分、电源相关建议部分、布局部分、器件和文档支持部分以及机械、封装和可订购信息部分。..... 1
- 删除了订购信息表；请参阅数据表末尾的 POA..... 1
- Deleted Lead temperature row..... 4
- Changed R<sub>θJA</sub> for D (SOIC) from 97 to 109.2 and for P (PDIP) from 85 to 51.4..... 5

## 5 Pin Configuration and Functions



图 5-1. D or P Package 8-Pin SOIC or PDIP Top View

## Pin Functions

PIN		I/O	DESCRIPTION
NAME	NO.		
CT	3	O	Timing capacitor input. The timing capacitor determines the time delay that the reset outputs remain active after the voltage at the SENSE input exceeds the positive-going threshold value.
GND	4	—	Ground
REF	1	O	Reference voltage. See <a href="#">§ 6.5</a> for reference voltage output and specification.
RESET	6	O	Active high reset. See <a href="#">图 6-1</a> for RESET function and timing.
RESET	5	O	Active low reset. See <a href="#">图 6-1</a> for $\overline{\text{RESET}}$ function and timing.
RESIN	2	I	Reset input. When the Reset Input is low, the RESET output goes high and the $\overline{\text{RESET}}$ goes low. When the Reset Input is high, the RESET and $\overline{\text{RESET}}$ outputs are allowed to trigger based on the SENSE voltage.
SENSE	7	I	Sense input. Voltage input to be supervised. See <a href="#">图 6-1</a> for SENSE function and timing.
VCC	8	—	Supply voltage. See <a href="#">§ 6.3</a> for recommended voltage input range.

## 6 Specifications

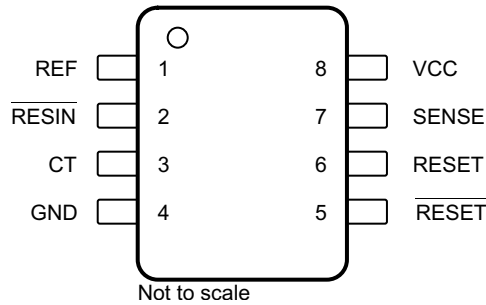
### 6.1 Absolute Maximum Ratings

over operating free-air temperature range (unless otherwise noted)<sup>(1)</sup>

		MIN	MAX	UNIT
Supply voltage <sup>(2)</sup> , $V_{CC}$			20	V
Input voltage, $V_I$	RESIN	- 0.3	20	V
	SENSE	- 0.3	20	
High-level output current, $I_{OH}$ (RESET)			- 30	mA
Low-level output current, $I_{OL}$ (RESET)			30	mA
Operating virtual junction temperature, $T_J$			150	°C
Storage temperature, $T_{stg}$		- 65	150	°C

(1) Stresses beyond those listed under *Absolute Maximum Ratings* may cause permanent damage to the device. These are stress ratings only, which do not imply functional operation of the device at these or any other conditions beyond those indicated under *Recommended Operating Conditions*. Exposure to absolute-maximum-rated conditions for extended periods may affect device reliability.

(2) All voltage values are with respect to the network ground terminal.

### 6.2 ESD Ratings

		VALUE	UNIT
$V_{(ESD)}$	Electrostatic discharge	Human-body model (HBM), per ANSI/ESDA/JEDEC JS-001 <sup>(1)</sup>	2000
		Charged-device model (CDM), per JEDEC specification JESD22-C101 <sup>(2)</sup>	1000

(1) JEDEC document JEP155 states that 500-V HBM allows safe manufacturing with a standard ESD control process.

(2) JEDEC document JEP157 states that 250-V CDM allows safe manufacturing with a standard ESD control process.

### 6.3 Recommended Operating Conditions

over operating free-air temperature range (unless otherwise noted)

		MIN	MAX	UNIT
$V_{CC}$	Supply voltage	3.6	18	V
$V_{IH}$	High-level input voltage	RESIN	2	18
$V_{IL}$	Low-level input voltage	RESIN	0	0.8
$V_I$	Input voltage	SENSE	0	18
$I_{OH}$	High-level output current	RESET	- 20	mA
$I_{OL}$	Low-level output current	RESET	20	mA
$T_A$	Operating free-air temperature	TL77xxBC	0	70
		TL77xxBI	- 40	85
		TL7705BQ	- 40	125

## 6.4 Thermal Information

THERMAL METRIC <sup>(1) (2)</sup>		TL77xxB		UNIT
		D (SOIC)	P (PDIP)	
		8 PINS	8 PINS	
$R_{\theta JA}$	Junction-to-ambient thermal resistance	109.2	51.4	°C/W
$R_{\theta JC(top)}$	Junction-to-case (top) thermal resistance	56	40.6	°C/W
$R_{\theta JB}$	Junction-to-board thermal resistance	49.9	28.6	°C/W
$\psi_{JT}$	Junction-to-top characterization parameter	11.4	17.7	°C/W
$\psi_{JB}$	Junction-to-board characterization parameter	49.4	28.5	°C/W

- (1) For more information about traditional and new thermal metrics, see the [Semiconductor and IC Package Thermal Metrics](#) application report.
- (2) Maximum power dissipation is a function of  $T_{J(max)}$ ,  $R_{\theta JA}$ , and  $T_A$ . The maximum allowable power dissipation at any allowable ambient temperature is  $P_D = (T_{J(max)} - T_A) / R_{\theta JA}$ . Operating at the absolute maximum  $T_J$  of 150°C can affect reliability.

### 6.5 Electrical Characteristics: TL77xxBC, TL77xxBI, and TL7705BQ

over operating free-air temperature range (unless otherwise noted)<sup>(1)</sup>

PARAMETER		TEST CONDITIONS	MIN	TYP	MAX	UNIT	
V <sub>OH</sub>	High-level output voltage, RESET	I <sub>OH</sub> = - 16 mA	V <sub>CC</sub> - 1.5			V	
V <sub>OL</sub>	Low-level output voltage, RESET	I <sub>OL</sub> = 16 mA	0.4			V	
V <sub>REF</sub>	Reference voltage, REF	I <sub>ref</sub> = - 500 μA, T <sub>A</sub> = 25°C	2.48	2.53	2.58	V	
V <sub>IT-</sub>	Negative-going input threshold voltage at SENSE input	TL7702B	T <sub>A</sub> = 25°C	2.505	2.53	2.555	V
		TL7705B		4.5	4.55	4.6	
		TL7733B		3.03	3.08	3.13	
		TL7702B	T <sub>A</sub> = full range <sup>(2)</sup>	2.48	2.53	2.58	
		TL7705B		4.45	4.55	4.65	
		TL7733B		3	3.08	3.16	
V <sub>HYS</sub>	Hysteresis, SENSE (V <sub>IT+</sub> - V <sub>IT-</sub> )	TL7702B	V <sub>CC</sub> = 3.6 V to 18 V, T <sub>A</sub> = 25°C			mV	
		TL7705B	10				
		TL7733B	30				
V <sub>RES</sub>	Power-up reset voltage <sup>(3)</sup>	I <sub>OL</sub> at RESET = 2 mA, T <sub>A</sub> = 25°C	1			V	
I <sub>I</sub>	Input current	RESIN	V <sub>I</sub> = 0.4 V to V <sub>CC</sub>			μA	
		SENSE, TL7702B	V <sub>I</sub> = V <sub>REF</sub> to 18 V				
I <sub>OH</sub>	High-level output current, RESET	V <sub>O</sub> = 18 V, see 图 7-1	50			μA	
I <sub>OL</sub>	Low-level output current, RESET	V <sub>O</sub> = 0 V, see 图 7-1	- 50			μA	
I <sub>CC</sub>	Supply current	V <sub>SENSE</sub> = 15 V, RESIN ≥ 2 V	1.8			mA	
		V <sub>CC</sub> = 18 V, T <sub>A</sub> = full range <sup>(2)</sup>	3.5				

(1) All electrical characteristics are measured with 0.1-μF capacitors connected at REF, CT, and VCC to GND.

(2) Full range is 0°C to 70°C for the C-suffix devices, - 40°C to 85°C for the I-suffix devices, and - 40°C to 125°C for the Q-suffix device.

(3) This is the lowest voltage at which RESET becomes active.

### 6.6 Switching Characteristics: TL77xxBC, TL77xxBI, and TL7705BQ

V<sub>CC</sub> = 5 V, C<sub>T</sub> open, T<sub>A</sub> = 25°C, over operating free-air temperature range (unless otherwise noted)

PARAMETER	FROM (INPUT)	TO (OUTPUT)	TEST CONDITIONS	MIN	TYP	MAX	UNIT
t <sub>PLH</sub>	RESIN	RESET	See , 图 6-1 图 6-2, 图 7-1		270	500	ns
t <sub>PHL</sub>	RESIN	RESET	See 图 6-1, 图 6-2, 图 7-2		270	500	ns
t <sub>w</sub>	RESIN		See 图 7-3, 图 7-4	150		ns	
	SENSE			100			
t <sub>r</sub>		RESET	See 图 6-1, 图 7-1, 图 7-2	75		ns	
		RESET		75 150			
t <sub>f</sub>		RESET	See 图 6-1, 图 7-1, 图 7-2	150 200		ns	
		RESET		50			

## 6.7 Timing Diagrams



图 6-1. TL7702B, TL7705B, and TL7733B Timing Diagram



图 6-2.  $V_{IT}$  and  $V_{RES}$  Timing Diagram

## 6.8 Typical Characteristics

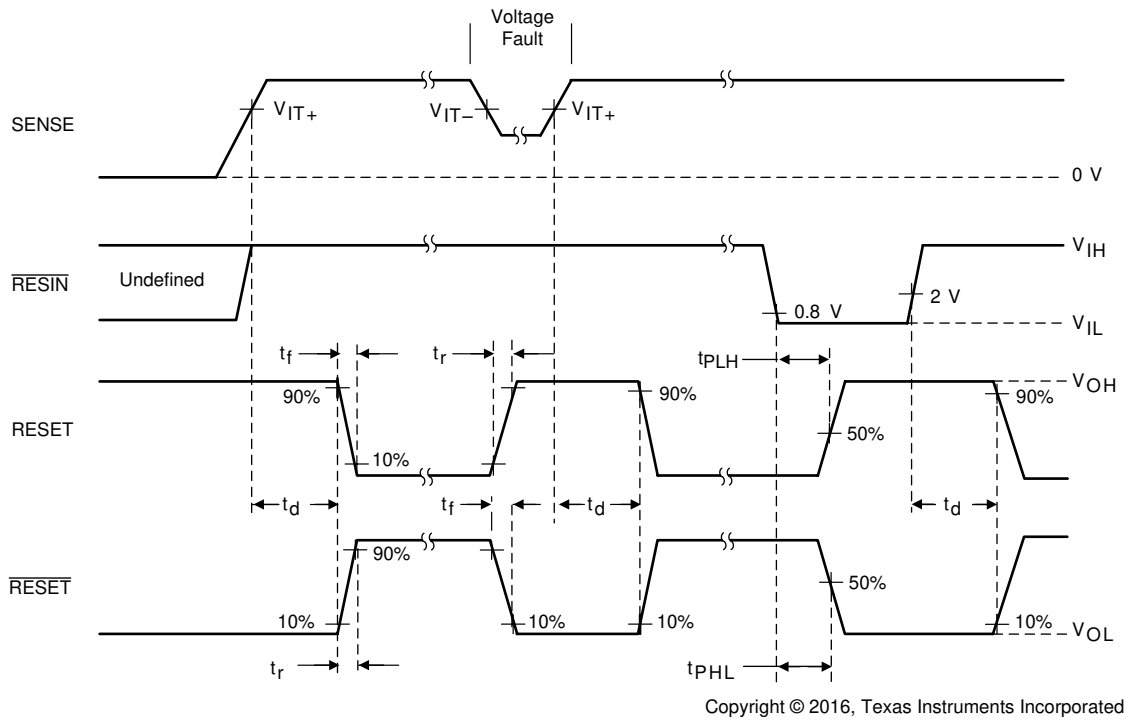

图 6-3. Assertion Time vs Load Resistance

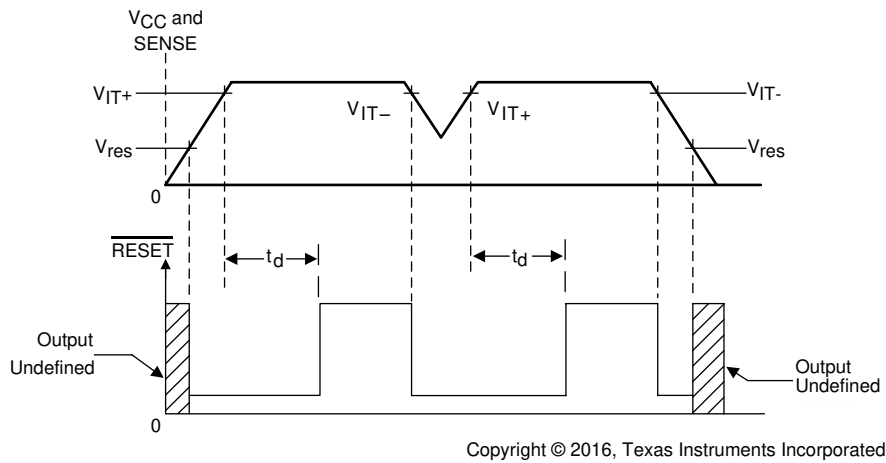

图 6-4. Deassertion Time vs Load Resistance

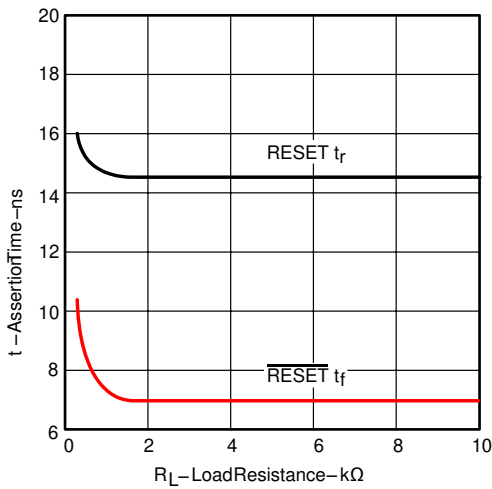

图 6-5. Assertion Time vs Load Capacitance

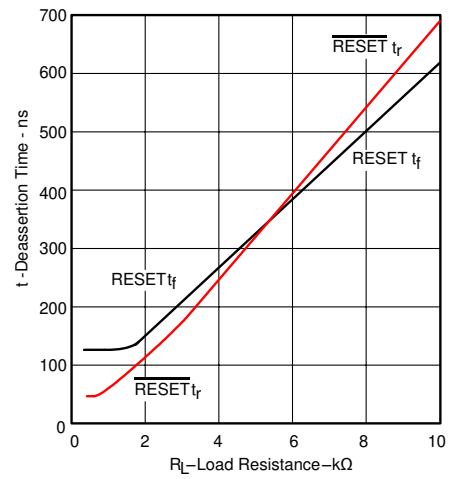

图 6-6. Deassertion Time vs Load Capacitance

## 7 Parameter Measurement Information

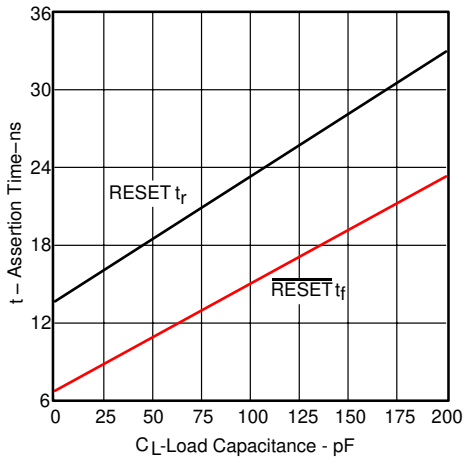

RESET OUTPUT CONFIGURATION

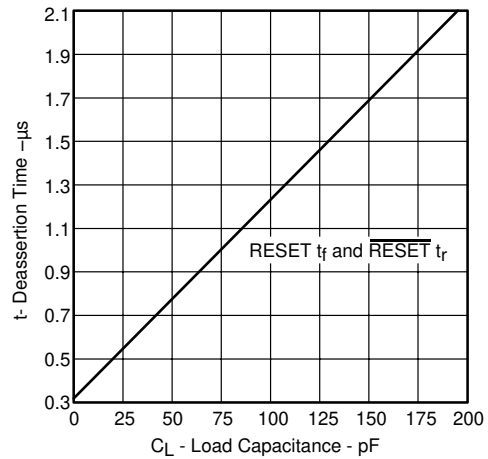
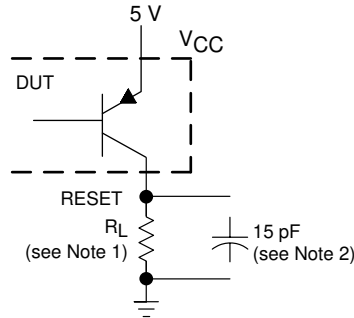
Copyright © 2016, Texas Instruments Incorporated

- A. For  $I_{OL}$  and  $I_{OH}$ ,  $R_L = 10\text{ k}\Omega$ . For all switching characteristics,  $R_L = 511\ \Omega$ .
- B. This figure includes jig and probe capacitance.

图 7-1. RESET Output Configuration

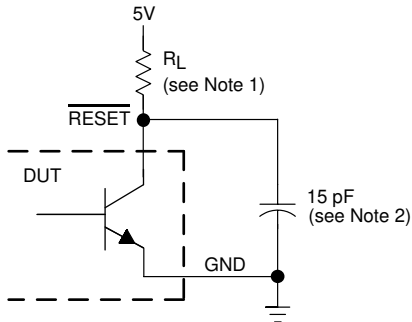

$\overline{\text{RESET}}$  OUTPUT CONFIGURATION

Copyright © 2016, Texas Instruments Incorporated

- A. For  $I_{OL}$  and  $I_{OH}$ ,  $R_L = 10\text{ k}\Omega$ . For all switching characteristics,  $R_L = 511\ \Omega$ .
- B. This figure includes jig and probe capacitance.

图 7-2.  $\overline{\text{RESET}}$  Output Configuration



图 7-3. Input Pulse Definition RESIN



图 7-4. Input Pulse Definition SENSE

## 8 Detailed Description

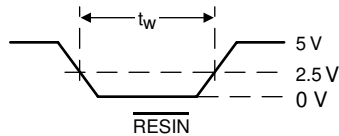
### 8.1 Overview

The TL7702B, TL7705B, and TL7733B are integrated-circuit supply-voltage supervisors designed for use as reset controllers in microcomputer and microprocessor systems. The supply-voltage supervisor monitors the supply for undervoltage conditions at the SENSE input. During power up, the  $\overline{\text{RESET}}$  output becomes active (low) when  $V_{CC}$  attains a value approaching 1 V. As  $V_{CC}$  approaches 3 V (assuming that SENSE is above  $V_{T+}$ ), the delay-timer function activates a time delay, after which outputs  $\overline{\text{RESET}}$  and RESET go inactive (high and low, respectively). When an undervoltage condition occurs during normal operation, outputs  $\overline{\text{RESET}}$  and RESET go active. To ensure that a complete reset occurs, the reset outputs remain active for a time delay after the voltage at the SENSE input exceeds the positive-going threshold value. The time delay is determined by the value of the external capacitor  $C_T$ :  $t_d \approx 2.6 \times 10^4 \times C_T$ , where  $C_T$  is in farads (F) and  $t_d$  is in seconds (s).

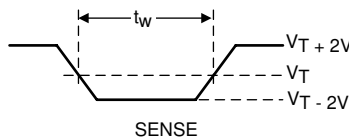
An external capacitor (typically 0.1  $\mu\text{F}$ ) must be connected to REF to reduce the influence of fast transients in the supply voltage.

### 8.2 Functional Block Diagram

The functional block diagram is shown for illustrative purposes only; the actual circuit includes a trimming network to adjust the reference voltage and sense-comparator trip point.

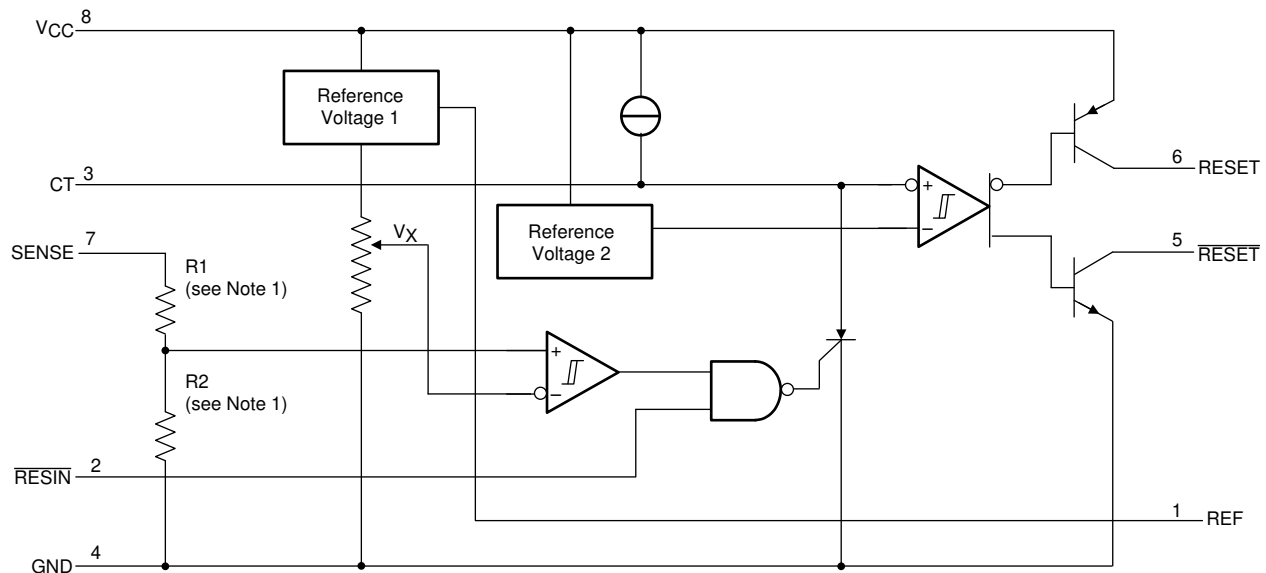

Copyright © 2016, Texas Instruments Incorporated

### 8.3 Feature Description

#### 8.3.1 Wide Supply-Voltage Range

The TL77xxB family operates using a wide supply voltage from 3.6 V to 18 V.

#### 8.3.2 Adjustable Pulse Duration

The CT pin enables the ability to set a user-defined time delay in order to ensure that the fault condition is recognized. The external capacitor charges based on an internal current source until the voltage at the CT pin exceeds that of the internal reference voltage.

The time delay is determined by the value of the external capacitor  $C_T$ :  $t_d \approx 2.6 \times 10^4 \times C_T$ , where  $C_T$  is in farads (F) and  $t_d$  is in seconds (s).

The current source to charge the timing capacitor varies  $\pm 15\%$ . Reference Voltage 2 is approximately 1.8 V and varies approximately  $\pm 5\%$ . Once the timing capacitor charges, it discharges to about 0.6 V, not completely to 0 V.

### 8.4 Device Functional Modes

图 8-1 displays how the RESET and  $\overline{\text{RESET}}$  output pins respond to the change in the the SENSE and  $\overline{\text{RESIN}}$  input pins. When the  $\overline{\text{RESIN}}$  pin is high, the RESET outputs are able to respond to a drop in the supply voltage at the SENSE pin. When the RESIN pin is low, the RESET and  $\overline{\text{RESET}}$  pins are set HIGH and LOW respectively.

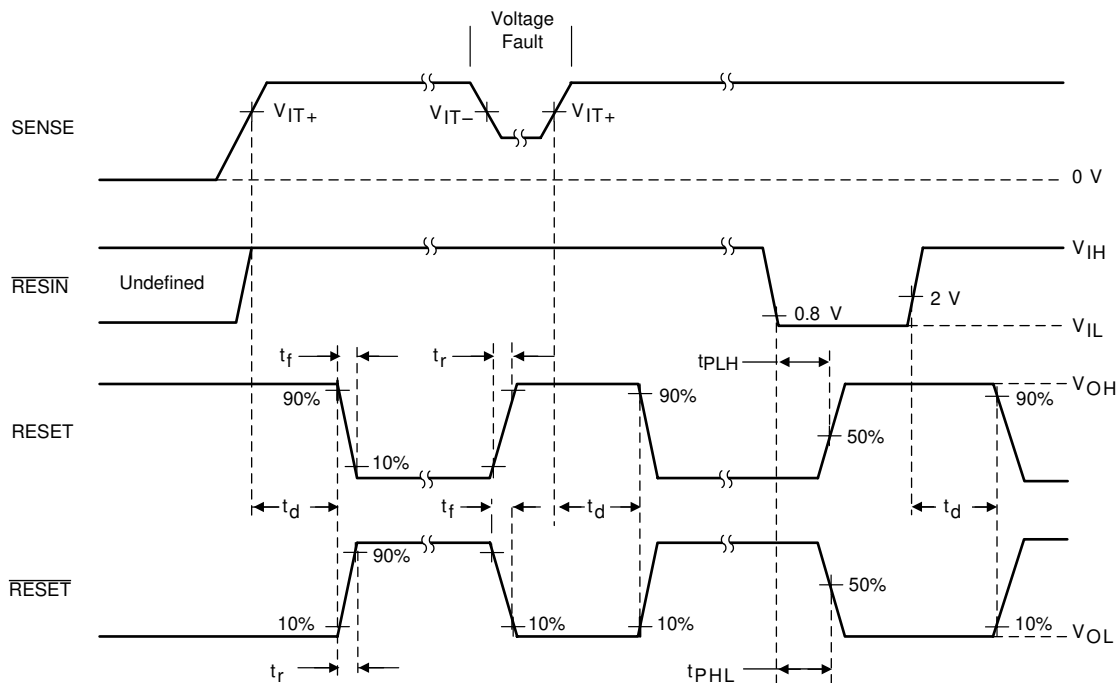

Copyright © 2016, Texas Instruments Incorporated

图 8-1. TL77xxB RESET and  $\overline{\text{RESET}}$  Response and Timing

## 9 Application and Implementation

### 备注

以下应用部分中的信息不属于 TI 器件规格的范围，TI 不担保其准确性和完整性。TI 的客户应负责确定器件是否适用于其应用。客户应验证并测试其设计，以确保系统功能。

### 9.1 Application Information

图 9-1 显示了一个应用，其中 TL7705B 器件正在用于检测电压供应，为以 5 V 供电的微控制器。如果电压供应低于阈值电压，RESET 引脚被拉低，信号微控制器复位。

### 9.2 Typical Application



图 9-1. Reset Controller Schematic for a Microprocessor

#### 9.2.1 Design Requirements

The external components required include the decoupling capacitor for the REF pin and the timing capacitor for the CT pin. Additionally, because the  $\overline{\text{RESET}}$  output is open collector, a pullup resistor is required to ensure the correct HIGH level for the microcontroller RESET pin.

#### 9.2.2 Detailed Design Procedure

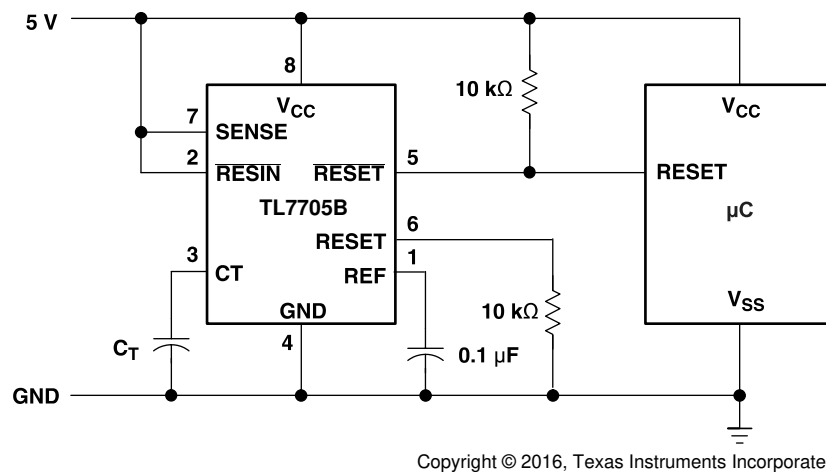
TI recommends pullup and pulldown resistors of 10 k $\Omega$ .

To achieve a 2.6 ms time delay, use  $C_T = 0.1 \mu\text{F}$ .

Both outputs of the TL770xB must be terminated with similar value resistors, even when only one is being used. This prevents unwanted plateauing in either output waveform during switching, which may be interpreted as an undefined state or delay system reset

### 9.2.3 Application Curve



图 9-2. TL7705B Threshold Voltage vs Temperature

## 10 Power Supply Recommendations

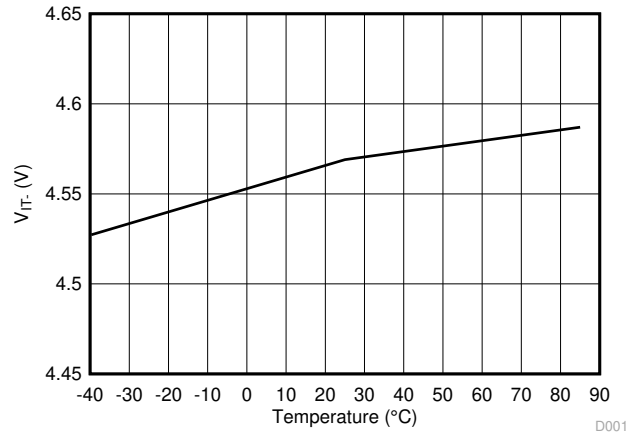
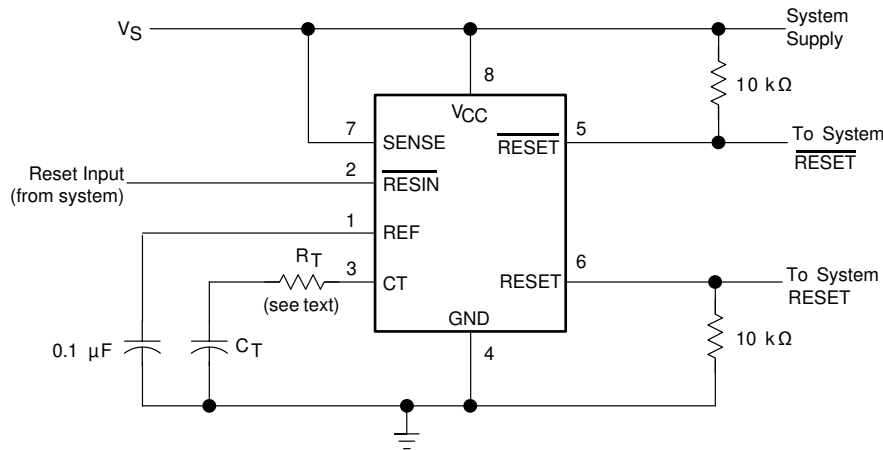

Copyright © 2016, Texas Instruments Incorporated

**图 10-1. System Reset Controller With Undervoltage Sensing**

When the TL770xB SENSE terminal is used to monitor  $V_{CC}$ , TI recommends a current-limiting resistor in series with  $C_T$ . During normal operation, the timing capacitor is charged by the onboard current source to approximately  $V_{CC}$  or an internal voltage clamp ( $\approx 7.1$ -V Zener), whichever is less. When the circuit then is subjected to an undervoltage condition during which  $V_{CC}$  is rapidly slewed down, the voltage on  $C_T$  exceeds that on  $V_{CC}$ . This forward biases a secondary path internally, which falsely activates the outputs. A fault is indicated when  $V_{CC}$  drops below  $V_{(CT)}$ , not when  $V_{SENSE}$  falls below  $V_{T-}$ .

Adding the external resistor,  $R_T$ , prevents false triggering. Its value is calculated as follows:

$$(V_{(CT)} - V_{T-}) / R_T \tag{1}$$

where

- $V_{(CT)} = V_{CC}$  or 7.1 V, whichever is less
- $V_{T-} = 4.55$  V (nom)
- $R_T =$  value of series resistor required

For  $V_{CC} = 5$  V

$$(5 - 4.55) / R_T < 1 \text{ mA} \tag{2}$$

Therefore,

$$R_T > 450 \ \Omega \tag{3}$$

Using a 20%-tolerance resistor,  $R_T$  should be greater than 560  $\Omega$ .

Adding this series resistor changes the duration of the reset pulse by no more than 10%.  $R_T$  extends the discharge of  $C_T$ , but also skews the  $V_{(CT)}$  threshold. These effects tend to cancel one another. The precise percentage change can be derived theoretically, but the equation is complicated by this interaction and is dependent upon the duration of the supply-voltage fault condition.

Both outputs of the TL770xB must be terminated with similar value resistors, even when only one is being used. This prevents unwanted plateauing in either output waveform during switching, which may be interpreted as an undefined state or delay system reset.

## 11 Layout

### 11.1 Layout Guidelines

Figure 11-1 shows an example layout for the TL7705B device. As the  $\overline{\text{RESET}}$  and RESET pins are open collector outputs, place pullup and pulldown resistors on the  $\overline{\text{RESET}}$  and RESET pins respectively. A capacitor must be placed on the REF pin to stabilize the reference. This can help to prevent false triggering if noise couples into the reference.

### 11.2 Layout Example



图 11-1. TL7705B Layout Example

## 12 Device and Documentation Support

### 12.1 Related Links

The table below lists quick access links. Categories include technical documents, support and community resources, tools and software, and quick access to sample or buy.

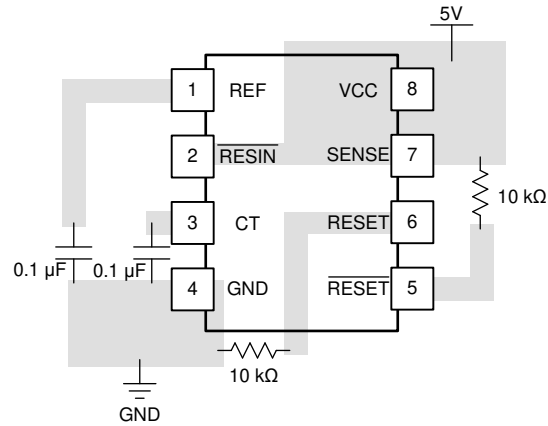
表 12-1. Related Links

PARTS	PRODUCT FOLDER	SAMPLE & BUY	TECHNICAL DOCUMENTS	TOOLS & SOFTWARE	SUPPORT & COMMUNITY
TL7702B	<a href="#">Click here</a>	<a href="#">Click here</a>	<a href="#">Click here</a>	<a href="#">Click here</a>	<a href="#">Click here</a>
TL7705B	<a href="#">Click here</a>	<a href="#">Click here</a>	<a href="#">Click here</a>	<a href="#">Click here</a>	<a href="#">Click here</a>
TL7733B	<a href="#">Click here</a>	<a href="#">Click here</a>	<a href="#">Click here</a>	<a href="#">Click here</a>	<a href="#">Click here</a>

### 12.2 接收文档更新通知

要接收文档更新通知，请导航至 [ti.com](http://ti.com) 上的器件产品文件夹。点击 [订阅更新](#) 进行注册，即可每周接收产品信息更改摘要。有关更改的详细信息，请查看任何已修订文档中包含的修订历史记录。

### 12.3 支持资源

TI E2E™ 支持论坛是工程师的重要参考资料，可直接从专家获得快速、经过验证的解答和设计帮助。搜索现有解答或提出自己的问题可获得所需的快速设计帮助。

链接的内容由各个贡献者“按原样”提供。这些内容并不构成 TI 技术规范，并且不一定反映 TI 的观点；请参阅 TI 的《使用条款》。

### 12.4 Trademarks

TI E2E™ is a trademark of Texas Instruments.

所有商标均为其各自所有者的财产。

### 12.5 静电放电警告



静电放电 (ESD) 会损坏这个集成电路。德州仪器 (TI) 建议通过适当的预防措施处理所有集成电路。如果不遵守正确的处理和安装程序，可能会损坏集成电路。

ESD 的损坏小至导致微小的性能降级，大至整个器件故障。精密的集成电路可能更容易受到损坏，这是因为非常细微的参数更改都可能会导致器件与其发布的规格不相符。

### 12.6 术语表

TI 术语表 本术语表列出并解释了术语、首字母缩略词和定义。

## 13 Mechanical, Packaging, and Orderable Information

The following pages include mechanical, packaging, and orderable information. This information is the most current data available for the designated devices. This data is subject to change without notice and revision of this document. For browser-based versions of this data sheet, refer to the left-hand navigation.

**PACKAGING INFORMATION**

Orderable part number	Status (1)	Material type (2)	Package   Pins	Package qty   Carrier	RoHS (3)	Lead finish/ Ball material (4)	MSL rating/ Peak reflow (5)	Op temp (°C)	Part marking (6)
<a href="#">TL7702BCD</a>	Active	Production	SOIC (D)   8	75   TUBE	Yes	NIPDAU	Level-1-260C-UNLIM	0 to 70	7702BC
TL7702BCD.A	Active	Production	SOIC (D)   8	75   TUBE	Yes	NIPDAU	Level-1-260C-UNLIM	0 to 70	7702BC
<a href="#">TL7702BCDR</a>	Active	Production	SOIC (D)   8	2500   LARGE T&R	Yes	NIPDAU	Level-1-260C-UNLIM	0 to 70	7702BC
TL7702BCDR.A	Active	Production	SOIC (D)   8	2500   LARGE T&R	Yes	NIPDAU	Level-1-260C-UNLIM	0 to 70	7702BC
<a href="#">TL7702BCP</a>	Active	Production	PDIP (P)   8	50   TUBE	Yes	NIPDAU	N/A for Pkg Type	0 to 70	TL7702BCP
TL7702BCP.A	Active	Production	PDIP (P)   8	50   TUBE	Yes	NIPDAU	N/A for Pkg Type	0 to 70	TL7702BCP
<a href="#">TL7702BID</a>	Active	Production	SOIC (D)   8	75   TUBE	Yes	NIPDAU	Level-1-260C-UNLIM	-40 to 85	7702BI
TL7702BID.A	Active	Production	SOIC (D)   8	75   TUBE	Yes	NIPDAU	Level-1-260C-UNLIM	-40 to 85	7702BI
<a href="#">TL7702BIDR</a>	Active	Production	SOIC (D)   8	2500   LARGE T&R	Yes	NIPDAU	Level-1-260C-UNLIM	-40 to 85	7702BI
TL7702BIDR.A	Active	Production	SOIC (D)   8	2500   LARGE T&R	Yes	NIPDAU	Level-1-260C-UNLIM	-40 to 85	7702BI
<a href="#">TL7702BIP</a>	Active	Production	PDIP (P)   8	50   TUBE	Yes	NIPDAU	N/A for Pkg Type	-40 to 85	TL7702BIP
TL7702BIP.A	Active	Production	PDIP (P)   8	50   TUBE	Yes	NIPDAU	N/A for Pkg Type	-40 to 85	TL7702BIP
<a href="#">TL7705BCD</a>	Active	Production	SOIC (D)   8	75   TUBE	Yes	NIPDAU	Level-2-260C-1 YEAR	0 to 70	7705BC
TL7705BCD.A	Active	Production	SOIC (D)   8	75   TUBE	Yes	NIPDAU	Level-2-260C-1 YEAR	0 to 70	7705BC
<a href="#">TL7705BCDR</a>	Active	Production	SOIC (D)   8	2500   LARGE T&R	Yes	NIPDAU	Level-2-260C-1 YEAR	0 to 70	7705BC
TL7705BCDR.A	Active	Production	SOIC (D)   8	2500   LARGE T&R	Yes	NIPDAU	Level-2-260C-1 YEAR	0 to 70	7705BC
<a href="#">TL7705BCP</a>	NRND	Production	PDIP (P)   8	50   TUBE	Yes	NIPDAU	N/A for Pkg Type	0 to 70	TL7705BCP
TL7705BCP.A	NRND	Production	PDIP (P)   8	50   TUBE	Yes	NIPDAU	N/A for Pkg Type	0 to 70	TL7705BCP
<a href="#">TL7705BID</a>	Active	Production	SOIC (D)   8	75   TUBE	Yes	NIPDAU	Level-2-260C-1 YEAR	-40 to 85	7705BI
TL7705BID.A	Active	Production	SOIC (D)   8	75   TUBE	Yes	NIPDAU	Level-2-260C-1 YEAR	-40 to 85	7705BI
<a href="#">TL7705BIDR</a>	Active	Production	SOIC (D)   8	2500   LARGE T&R	Yes	NIPDAU	Level-2-260C-1 YEAR	-40 to 85	7705BI
TL7705BIDR.A	Active	Production	SOIC (D)   8	2500   LARGE T&R	Yes	NIPDAU	Level-2-260C-1 YEAR	-40 to 85	7705BI
<a href="#">TL7705BIP</a>	NRND	Production	PDIP (P)   8	50   TUBE	Yes	NIPDAU	N/A for Pkg Type	-40 to 85	TL7705BIP
TL7705BIP.A	NRND	Production	PDIP (P)   8	50   TUBE	Yes	NIPDAU	N/A for Pkg Type	-40 to 85	TL7705BIP
<a href="#">TL7705BQD</a>	Active	Production	SOIC (D)   8	75   TUBE	Yes	NIPDAU	Level-1-260C-UNLIM	-40 to 125	7705BQ
TL7705BQD.A	Active	Production	SOIC (D)   8	75   TUBE	Yes	NIPDAU	Level-1-260C-UNLIM	-40 to 125	7705BQ
<a href="#">TL7705BQDG4</a>	Active	Production	SOIC (D)   8	75   TUBE	Yes	NIPDAU	Level-1-260C-UNLIM	-40 to 125	7705BQ
TL7705BQDG4.A	Active	Production	SOIC (D)   8	75   TUBE	Yes	NIPDAU	Level-1-260C-UNLIM	-40 to 125	7705BQ
<a href="#">TL7705BQDR</a>	Active	Production	SOIC (D)   8	2500   LARGE T&R	Yes	NIPDAU	Level-1-260C-UNLIM	-40 to 125	7705BQ

Orderable part number	Status (1)	Material type (2)	Package   Pins	Package qty   Carrier	RoHS (3)	Lead finish/ Ball material (4)	MSL rating/ Peak reflow (5)	Op temp (°C)	Part marking (6)
TL7705BQDR.A	Active	Production	SOIC (D)   8	2500   LARGE T&R	Yes	NIPDAU	Level-1-260C-UNLIM	-40 to 125	7705BQ
<a href="#">TL7705BQDRG4</a>	Active	Production	SOIC (D)   8	2500   LARGE T&R	Yes	NIPDAU	Level-1-260C-UNLIM	-40 to 125	7705BQ
TL7705BQDRG4.A	Active	Production	SOIC (D)   8	2500   LARGE T&R	Yes	NIPDAU	Level-1-260C-UNLIM	-40 to 125	7705BQ
<a href="#">TL7733BCD</a>	Active	Production	SOIC (D)   8	75   TUBE	Yes	NIPDAU	Level-1-260C-UNLIM	0 to 70	7733BC
TL7733BCD.A	Active	Production	SOIC (D)   8	75   TUBE	Yes	NIPDAU	Level-1-260C-UNLIM	0 to 70	7733BC
<a href="#">TL7733BCDR</a>	Active	Production	SOIC (D)   8	2500   LARGE T&R	Yes	NIPDAU	Level-1-260C-UNLIM	0 to 70	7733BC
TL7733BCDR.A	Active	Production	SOIC (D)   8	2500   LARGE T&R	Yes	NIPDAU	Level-1-260C-UNLIM	0 to 70	7733BC
<a href="#">TL7733BCP</a>	Active	Production	PDIP (P)   8	50   TUBE	Yes	NIPDAU	N/A for Pkg Type	0 to 70	TL7733BCP
TL7733BCP.A	Active	Production	PDIP (P)   8	50   TUBE	Yes	NIPDAU	N/A for Pkg Type	0 to 70	TL7733BCP
<a href="#">TL7733BID</a>	Active	Production	SOIC (D)   8	75   TUBE	Yes	NIPDAU	Level-1-260C-UNLIM	-40 to 85	7733BI
TL7733BID.A	Active	Production	SOIC (D)   8	75   TUBE	Yes	NIPDAU	Level-1-260C-UNLIM	-40 to 85	7733BI
<a href="#">TL7733BIDR</a>	Active	Production	SOIC (D)   8	2500   LARGE T&R	Yes	NIPDAU	Level-1-260C-UNLIM	-40 to 85	7733BI
TL7733BIDR.A	Active	Production	SOIC (D)   8	2500   LARGE T&R	Yes	NIPDAU	Level-1-260C-UNLIM	-40 to 85	7733BI

(1) **Status:** For more details on status, see our [product life cycle](#).

(2) **Material type:** When designated, preproduction parts are prototypes/experimental devices, and are not yet approved or released for full production. Testing and final process, including without limitation quality assurance, reliability performance testing, and/or process qualification, may not yet be complete, and this item is subject to further changes or possible discontinuation. If available for ordering, purchases will be subject to an additional waiver at checkout, and are intended for early internal evaluation purposes only. These items are sold without warranties of any kind.

(3) **RoHS values:** Yes, No, RoHS Exempt. See the [TI RoHS Statement](#) for additional information and value definition.

(4) **Lead finish/Ball material:** Parts may have multiple material finish options. Finish options are separated by a vertical ruled line. Lead finish/Ball material values may wrap to two lines if the finish value exceeds the maximum column width.

(5) **MSL rating/Peak reflow:** The moisture sensitivity level ratings and peak solder (reflow) temperatures. In the event that a part has multiple moisture sensitivity ratings, only the lowest level per JEDEC standards is shown. Refer to the shipping label for the actual reflow temperature that will be used to mount the part to the printed circuit board.

(6) **Part marking:** There may be an additional marking, which relates to the logo, the lot trace code information, or the environmental category of the part.

Multiple part markings will be inside parentheses. Only one part marking contained in parentheses and separated by a "-" will appear on a part. If a line is indented then it is a continuation of the previous line and the two combined represent the entire part marking for that device.

**Important Information and Disclaimer:** The information provided on this page represents TI's knowledge and belief as of the date that it is provided. TI bases its knowledge and belief on information provided by third parties, and makes no representation or warranty as to the accuracy of such information. Efforts are underway to better integrate information from third parties. TI has taken and continues to take reasonable steps to provide representative and accurate information but may not have conducted destructive testing or chemical analysis on incoming materials and chemicals. TI and TI suppliers consider certain information to be proprietary, and thus CAS numbers and other limited information may not be available for release.

In no event shall TI's liability arising out of such information exceed the total purchase price of the TI part(s) at issue in this document sold by TI to Customer on an annual basis.

**TAPE AND REEL INFORMATION**

**QUADRANT ASSIGNMENTS FOR PIN 1 ORIENTATION IN TAPE**



\*All dimensions are nominal

Device	Package Type	Package Drawing	Pins	SPQ	Reel Diameter (mm)	Reel Width W1 (mm)	A0 (mm)	B0 (mm)	K0 (mm)	P1 (mm)	W (mm)	Pin1 Quadrant
TL7702BCDR	SOIC	D	8	2500	330.0	12.4	6.4	5.2	2.1	8.0	12.0	Q1
TL7702BIDR	SOIC	D	8	2500	330.0	12.4	6.4	5.2	2.1	8.0	12.0	Q1
TL7705BCDR	SOIC	D	8	2500	330.0	12.4	6.4	5.2	2.1	8.0	12.0	Q1
TL7705BIDR	SOIC	D	8	2500	330.0	12.4	6.4	5.2	2.1	8.0	12.0	Q1
TL7705BQDR	SOIC	D	8	2500	330.0	12.4	6.4	5.2	2.1	8.0	12.0	Q1
TL7705BQDRG4	SOIC	D	8	2500	330.0	12.4	6.4	5.2	2.1	8.0	12.0	Q1
TL7733BCDR	SOIC	D	8	2500	330.0	12.4	6.4	5.2	2.1	8.0	12.0	Q1
TL7733BIDR	SOIC	D	8	2500	330.0	12.4	6.4	5.2	2.1	8.0	12.0	Q1

**TAPE AND REEL BOX DIMENSIONS**

\*All dimensions are nominal

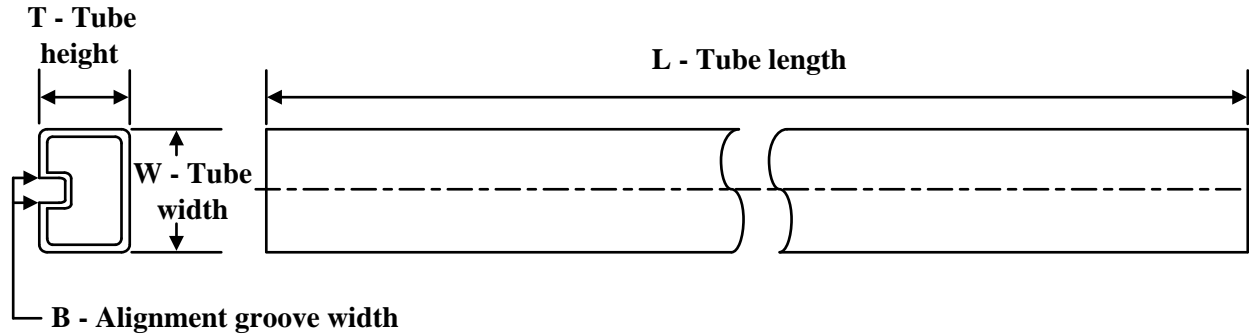
Device	Package Type	Package Drawing	Pins	SPQ	Length (mm)	Width (mm)	Height (mm)
TL7702BCDR	SOIC	D	8	2500	353.0	353.0	32.0
TL7702BIDR	SOIC	D	8	2500	353.0	353.0	32.0
TL7705BCDR	SOIC	D	8	2500	353.0	353.0	32.0
TL7705BIDR	SOIC	D	8	2500	353.0	353.0	32.0
TL7705BQDR	SOIC	D	8	2500	350.0	350.0	43.0
TL7705BQDRG4	SOIC	D	8	2500	350.0	350.0	43.0
TL7733BCDR	SOIC	D	8	2500	353.0	353.0	32.0
TL7733BIDR	SOIC	D	8	2500	353.0	353.0	32.0

**TUBE**

\*All dimensions are nominal

Device	Package Name	Package Type	Pins	SPQ	L (mm)	W (mm)	T (μm)	B (mm)
TL7702BCD	D	SOIC	8	75	507	8	3940	4.32
TL7702BCD.A	D	SOIC	8	75	507	8	3940	4.32
TL7702BCP	P	PDIP	8	50	506	13.97	11230	4.32
TL7702BCP.A	P	PDIP	8	50	506	13.97	11230	4.32
TL7702BID	D	SOIC	8	75	507	8	3940	4.32
TL7702BID.A	D	SOIC	8	75	507	8	3940	4.32
TL7702BIP	P	PDIP	8	50	506	13.97	11230	4.32
TL7702BIP.A	P	PDIP	8	50	506	13.97	11230	4.32
TL7705BCD	D	SOIC	8	75	507	8	3940	4.32
TL7705BCD.A	D	SOIC	8	75	507	8	3940	4.32
TL7705BCP	P	PDIP	8	50	506	13.97	11230	4.32
TL7705BCP.A	P	PDIP	8	50	506	13.97	11230	4.32
TL7705BID	D	SOIC	8	75	507	8	3940	4.32
TL7705BID.A	D	SOIC	8	75	507	8	3940	4.32
TL7705BIP	P	PDIP	8	50	506	13.97	11230	4.32
TL7705BIP.A	P	PDIP	8	50	506	13.97	11230	4.32
TL7705BQD	D	SOIC	8	75	505.46	6.76	3810	4
TL7705BQD.A	D	SOIC	8	75	505.46	6.76	3810	4
TL7705BQDG4	D	SOIC	8	75	505.46	6.76	3810	4
TL7705BQDG4.A	D	SOIC	8	75	505.46	6.76	3810	4
TL7733BCD	D	SOIC	8	75	507	8	3940	4.32
TL7733BCD.A	D	SOIC	8	75	507	8	3940	4.32
TL7733BCP	P	PDIP	8	50	506	13.97	11230	4.32
TL7733BCP.A	P	PDIP	8	50	506	13.97	11230	4.32
TL7733BID	D	SOIC	8	75	507	8	3940	4.32
TL7733BID.A	D	SOIC	8	75	507	8	3940	4.32



# EXAMPLE BOARD LAYOUT

D0008A

SOIC - 1.75 mm max height

SMALL OUTLINE INTEGRATED CIRCUIT



LAND PATTERN EXAMPLE  
 EXPOSED METAL SHOWN  
 SCALE:8X



SOLDER MASK DETAILS

4214825/C 02/2019

NOTES: (continued)

- 6. Publication IPC-7351 may have alternate designs.
- 7. Solder mask tolerances between and around signal pads can vary based on board fabrication site.

# EXAMPLE STENCIL DESIGN

D0008A

SOIC - 1.75 mm max height

SMALL OUTLINE INTEGRATED CIRCUIT



SOLDER PASTE EXAMPLE  
BASED ON .005 INCH [0.125 MM] THICK STENCIL  
SCALE:8X

4214825/C 02/2019

NOTES: (continued)

8. Laser cutting apertures with trapezoidal walls and rounded corners may offer better paste release. IPC-7525 may have alternate design recommendations.
9. Board assembly site may have different recommendations for stencil design.

P (R-PDIP-T8)

PLASTIC DUAL-IN-LINE PACKAGE



- NOTES:
- A. All linear dimensions are in inches (millimeters).
  - B. This drawing is subject to change without notice.
  - C. Falls within JEDEC MS-001 variation BA.

## 重要通知和免责声明

TI“按原样”提供技术和可靠性数据（包括数据表）、设计资源（包括参考设计）、应用或其他设计建议、网络工具、安全信息和其他资源，不保证没有瑕疵且不做任何明示或暗示的担保，包括但不限于对适销性、与某特定用途的适用性或不侵犯任何第三方知识产权的暗示担保。

这些资源可供使用 TI 产品进行设计的熟练开发人员使用。您将自行承担以下全部责任：(1) 针对您的应用选择合适的 TI 产品，(2) 设计、验证并测试您的应用，(3) 确保您的应用满足相应标准以及任何其他安全、安保法规或其他要求。

这些资源如有变更，恕不另行通知。TI 授权您仅可将这些资源用于研发本资源所述的 TI 产品的相关应用。严禁以其他方式对这些资源进行复制或展示。您无权使用任何其他 TI 知识产权或任何第三方知识产权。对于因您对这些资源的使用而对 TI 及其代表造成的任何索赔、损害、成本、损失和债务，您将全额赔偿，TI 对此概不负责。

TI 提供的产品受 [TI 销售条款](#)、[TI 通用质量指南](#) 或 [ti.com](#) 上其他适用条款或 TI 产品随附的其他适用条款的约束。TI 提供这些资源并不会扩展或以其他方式更改 TI 针对 TI 产品发布的适用的担保或担保免责声明。除非德州仪器 (TI) 明确将某产品指定为定制产品或客户特定产品，否则其产品均为按确定价格收入目录的标准通用器件。

TI 反对并拒绝您可能提出的任何其他或不同的条款。

版权所有 © 2026，德州仪器 (TI) 公司

最后更新日期：2025 年 10 月