

TLV8x3 具有低电平有效的开漏复位功能的 3 引脚电压监控器

1 特性

- 3 引脚 SOT23 封装
- 电源电流：9 μ A (典型值)
- 精密电源电压监控器：2.5V、3V、3.3V、5V
- 固定延时时间为 200ms 的上电复位发生器
- 与 MAX803 引脚兼容
- 温度范围：-40°C 至 +125°C
- 开漏、 $\overline{\text{RESET}}$ 输出

2 应用

- 工厂自动化
- 便携式和电池供电类设备
- 机顶盒
- 服务器
- 电器
- 电表
- 楼宇自动化

3 说明

TLV8x3 系列监控电路主要为数字信号处理器 (DSP) 以及基于处理器的系统提供电路初始化和时序监控。

TLV803、TLV853 和 TLV863 在功能上是等效的。TLV853 和 TLV863 分别提供了与 TLV803 不同的替代引脚分配。新款 [TLV803E](#) 器件是所有这 3 种器件的引脚对引脚替代品。

上电期间， $\overline{\text{RESET}}$ 会在电源电压 (V_{DD}) 超出 1.1V 时置为有效。因此只要满足以下条件，监控电路就会监视 V_{DD} 并将 $\overline{\text{RESET}}$ 保持为有效状态： V_{DD} 保持在阈值电压 V_{IT} 以下。内部定时器将使输出延迟恢复至待机状态 (高电平)，以确保系统正常复位。延迟时间 ($t_{\text{d(typ)}}$) = 200ms) 从 V_{DD} 超过阈值电压 V_{IT} 后开始。当电源电压降至阈值电压 V_{IT} 以下时，输出再次变为激活状态 (低电平)。该系列中的所有器件均具有一个通过内部分压器设定的固定感测阈值电压 (V_{IT})。

该产品系列专为 2.5V、3V、3.3 以及 5V 电源电压而设计。这些器件采用 3 引脚小外形尺寸晶体管 (SOT)-23 封装。TLV803 器件的额定工作温度范围为 -40°C 至 +125°C。

器件信息⁽¹⁾

器件型号	封装	封装尺寸 (标称值)
TLV8x3	SOT-23 (3)	2.92mm × 1.30mm

(1) 如需了解所有可用封装，请参阅数据表末尾的封装选项附录。

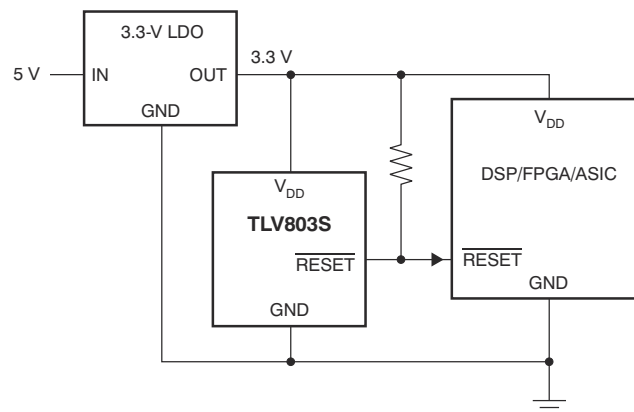

典型应用



Table of Contents

1 特性.....	1	8.4 Device Functional Modes.....	9
2 应用.....	1	9 Application and Implementation.....	10
3 说明.....	1	9.1 Application Information.....	10
4 Revision History.....	2	9.2 Typical Application.....	11
5 Device Comparison.....	4	10 Power Supply Recommendations.....	12
6 Pin Configuration and Functions.....	4	11 Layout.....	13
Pin Functions.....	4	11.1 Layout Guidelines.....	13
7 Specifications.....	5	11.2 Layout Example.....	13
7.1 Absolute Maximum Ratings ⁽¹⁾	5	12 Device and Documentation Support.....	14
7.2 ESD Ratings.....	5	12.1 Device Support.....	14
7.3 Thermal Information.....	5	12.2 Documentation Support.....	14
7.4 Recommended Operating Conditions.....	5	12.3 Related Links.....	14
7.5 Electrical Characteristics.....	6	12.4 支持资源.....	14
7.6 Switching Characteristics.....	6	12.5 Trademarks.....	15
7.7 Typical Characteristics.....	7	12.6 静电放电警告.....	15
8 Detailed Description.....	8	12.7 术语表.....	15
8.1 Overview.....	8	13 Mechanical, Packaging, and Orderable Information.....	15
8.2 Functional Block Diagram.....	8		
8.3 Feature Description.....	8		

4 Revision History

注：以前版本的页码可能与当前版本的页码不同

Changes from Revision D (November 2020) to Revision E (December 2020)	Page
• Corrected missed VDD change from 7 to 6.5 in <i>Absolute Maximum Ratings</i> in note 2.....	5
Changes from Revision C (September 2015) to Revision D (November 2020)	Page
• 更新了整个文档中的表格、图和交叉参考的编号格式.....	1
• 向 <i>说明</i> 部分添加了有关 TLV803E 的描述.....	1
• Changed VDD from 7 to 6.5 in <i>Absolute Maximum Ratings</i>	5
• Changed $V_{OL}@ 500 \mu A$ from 0.2 to 0.3 in <i>Electrical Characteristics</i>	6
• Changed I_{OH} from 100 nA to 350 nA in <i>Electrical Characteristics</i>	6
• Changed t_w from 1 to 10 μs in <i>Switching Characteristics</i>	6
• Deleted figure Minimum Pulse Duration At V_{DD} vs Overdrive Voltage in Typical Characteristics.....	7
• Changed figure from Pulse Duration to V_{OL} , I_{OL} in the Typical Application Section.....	12
Changes from Revision B (August 2011) to Revision C (September 2015)	Page
• 向数据表添加了 TLV853 器件.....	1
• 更改了页眉中显示的器件型号，以显示单个 TLV803 器件，而不是标有字母的器件版本.....	1
• 添加了 <i>器件信息表</i> 和 <i>ESD 等级表</i>	1
• 添加了 <i>详细说明、应用和实现、电源相关建议、布局、器件和文档支持</i> 以及 <i>机械、封装和可订购信息</i> 部分....	1
• 更改了 <i>应用</i> 部分的列表项.....	1
• 删除了首页中的引脚排列并将其移至 <i>引脚配置和功能</i> 部分.....	1
• Changed "free-air temperature" to "junction temperature" in <i>Absolute Maximum Ratings</i> condition statement.....	5
• Deleted <i>Soldering temperature</i> from <i>Absolute Maximum Ratings</i> table.....	5
• Changed <i>Thermal Information</i> table; updated thermal resistance values for all parameters.....	5
• Changed "free-air temperature" to "junction temperature" in <i>Electrical Characteristics</i> condition statement....	6
• Changed temperature noted in <i>Switching Characteristics</i> condition statement.....	6

Changes from Revision A (June 2011) to Revision B (August 2011)	Page
• 向说明部分添加了有关 TLV863 的段落.....	1
• 在首页中添加了 TLV863 引脚排列.....	1
• Added TLV863 to Thermal Information.....	5
• Added TLV863M to Negative-Going Input Threshold Voltage parameter.....	6
• Added TLV863M to Hysteresis parameter.....	6
• Added TLV863 to Functional Block Diagram.....	8

5 Device Comparison

表 5-1. Device Threshold Options

DEVICE	THRESHOLD VOLTAGE
TLV803Z	2.25 V
TLV803R	2.64 V
TLV803S	2.93 V
TLV803M	4.38 V
TLV853M	4.38 V
TLV863M	4.38 V

表 5-2. Device Family Comparison

DEVICE	FUNCTION
TLV803	Open-Drain, RESET Output
TLV809	Push-Pull, RESET Output
TLV810	Push-Pull, RESET Output

6 Pin Configuration and Functions



图 6-1. TLV803: DBZ Package
3-Pin SOT-23
Top View



图 6-2. TLV853: DBZ Package
3-Pin SOT-23
Top View

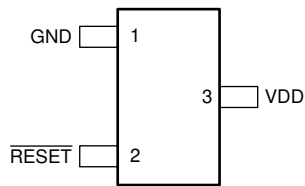

图 6-3. TLV863: DBZ Package
3-Pin SOT-23
Top View

Pin Functions

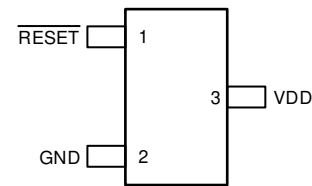
NAME	PIN			I/O	DESCRIPTION
	TLV803	TLV853	TLV863		
GND	1	2	3	—	Ground pin.
RESET	2	1	1	O	RESET is an open-drain output that is driven to a low impedance state when RESET is asserted. RESET remains low (asserted) for the delay time (t_d) after V_{DD} exceeds V_{IT} . Use a 10-k Ω to 1-M Ω pullup resistor on this pin. The pullup voltage is not limited by V_{DD} .
VDD	3	3	2	I	Supply voltage pin. It is good analog design practice to place a 0.1- μ F ceramic capacitor close to this pin.

7 Specifications

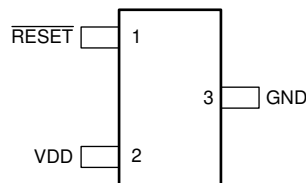
7.1 Absolute Maximum Ratings⁽¹⁾

over operating junction temperature range (unless otherwise noted)

		MIN	MAX	UNIT
Voltage	VDD ⁽²⁾	0	6.5	V
	All other pins ⁽²⁾	- 0.3	+6.5	
Current	Maximum low output current, I _{OL}		5	mA
	Maximum high output current, I _{OH}		- 5	
	Input clamp current, I _{IK} (V _I < 0 or V _I > V _{DD})		±20	
	Output clamp current, I _{OK} (V _O < 0 or V _O > V _{DD})		±20	
Temperature	Operating junction temperature range, T _J	- 40	125	°C
	Storage temperature range, T _{stg}	- 65	150	

- (1) Stresses beyond those listed under *Absolute Maximum Ratings* may cause permanent damage to the device. These are stress ratings only, and functional operation of the device at these or any other conditions beyond those indicated under *Recommended Operating Conditions* is not implied. Exposure to absolute-maximum-rated conditions for extended periods may affect device reliability.
- (2) All voltage values are with respect to GND. For reliable operation the device should not be operated at 6.5 V for more than t = 1000h continuously

7.2 ESD Ratings

			VALUE	UNIT
V _(ESD)	Electrostatic discharge	Human-body model (HBM), per ANSI/ESDA/JEDEC JS-001 ⁽¹⁾	±2000	V
		Charged-device model (CDM), per JEDEC specification JESD22-C101 ⁽²⁾	±500	

- (1) JEDEC document JEP155 states that 500-V HBM allows safe manufacturing with a standard ESD control process.
- (2) JEDEC document JEP157 states that 250-V CDM allows safe manufacturing with a standard ESD control process.

7.3 Thermal Information

THERMAL METRIC ⁽¹⁾		TLV8x3	UNITS
		DBZ (SOT-23)	
		3 PINS	
R _{θJA}	Junction-to-ambient thermal resistance	328.5	°C/W
R _{θJC(top)}	Junction-to-case (top) thermal resistance	135.4	°C/W
R _{θJB}	Junction-to-board thermal resistance	58.3	°C/W
ψ _{JT}	Junction-to-top characterization parameter	5.2	°C/W
ψ _{JB}	Junction-to-board characterization parameter	59.6	°C/W
R _{θJC(bot)}	Junction-to-case (bottom) thermal resistance	N/A	°C/W

- (1) For more information about traditional and new thermal metrics, see the *IC Package Thermal Metrics* application report, [SPRA953](#).

7.4 Recommended Operating Conditions

at specified temperature range (unless otherwise noted)

		MIN	MAX	UNIT
V _{DD}	Supply voltage	1.1	6	V
T _J	Operating junction temperature	- 40	125	°C

7.5 Electrical Characteristics

over recommended operating junction temperature range (unless otherwise noted)

PARAMETER		TEST CONDITIONS	MIN	TYP	MAX	UNIT	
V _{OL}	Low-level output voltage	V _{DD} = 2 V to 6 V, I _{OL} = 500 μA			0.3	V	
		V _{DD} = 3.3 V, I _{OL} = 2 mA			0.4		
		V _{DD} = 6 V, I _{OL} = 4 mA			0.4		
Power-up reset voltage ⁽¹⁾		I _{OL} = 50 μA, V _{OL} < 0.2 V	1.1			V	
V _{IT-}	Negative-going input threshold voltage ⁽²⁾	T _J = - 40°C to +125°C	TLV803Z	2.20	2.25	2.30	V
			TLV803R	2.58	2.64	2.70	
			TLV803S	2.87	2.93	2.99	
			TLV8x3M	4.28	4.38	4.48	
V _{hys}	Hysteresis	T _J = 25°C, I _{OL} = 50 μA	TLV803Z		30		mV
			TLV803R		35		
			TLV803S		40		
			TLV8x3M		60		
I _{DD}	Supply current	V _{DD} = 2 V, output unconnected		9	15	μA	
		V _{DD} = 6 V, output unconnected		20	30		
I _{OH}	Output leakage current	V _{DD} = 6 V			350	nA	

(1) The lowest supply voltage at which $\overline{\text{RESET}}$ becomes valid. $t_{r,VDD} \leq 66.7 \text{ V/ms}$.

(2) To ensure best stability of the threshold voltage, place a bypass capacitor (0.1-μF ceramic) near the supply terminals.

7.6 Switching Characteristics

over operating temperature range (unless otherwise noted)

PARAMETER	TEST CONDITIONS	MIN	TYP	MAX	UNIT	
t _w	Pulse duration at V _{DD}		10		μs	
t _d	Delay time	V _{DD} ≥ V _{IT-} + 0.2 V; see Timing Diagram	120	200	280	ms



图 7-1. Timing Diagram

7.7 Typical Characteristics

at $T_J = 25^\circ\text{C}$, $V_{IT-} = 4.38\text{ V}$, and $V_{DD} = 5.0\text{ V}$ (unless otherwise noted)

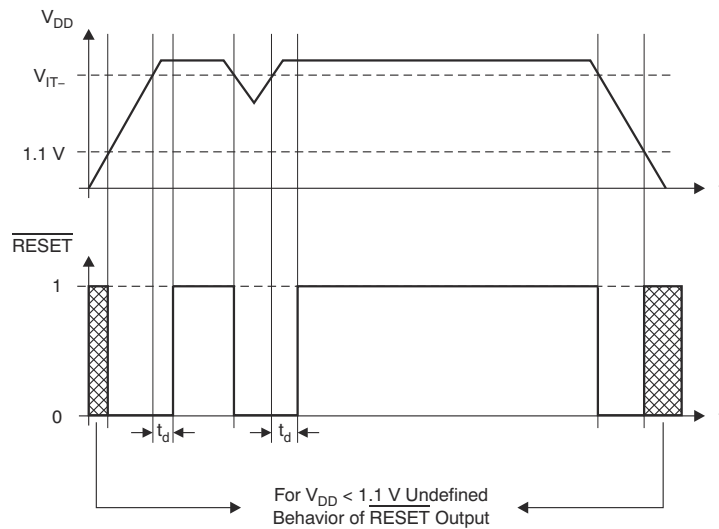
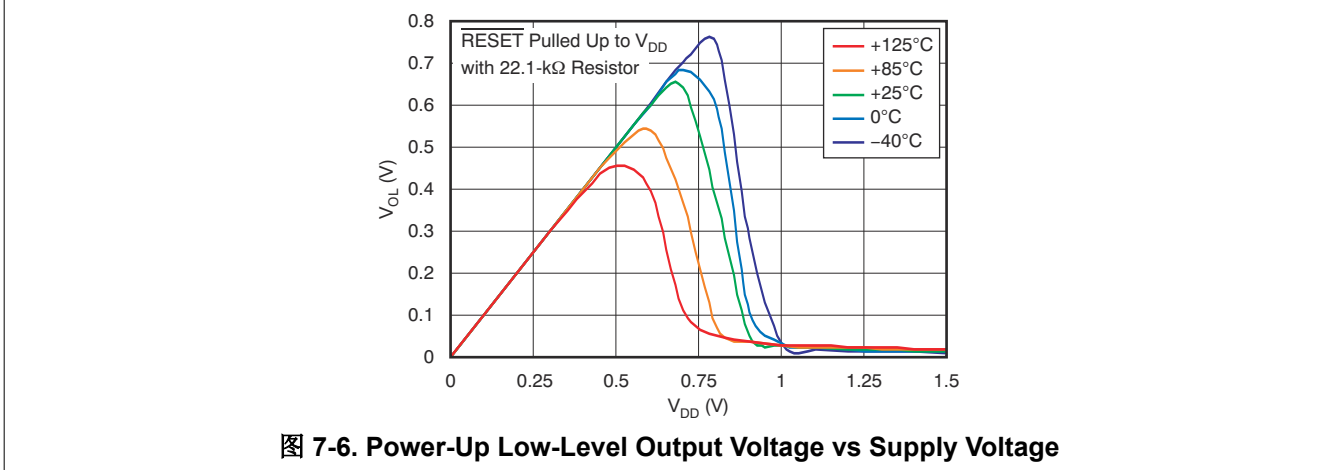
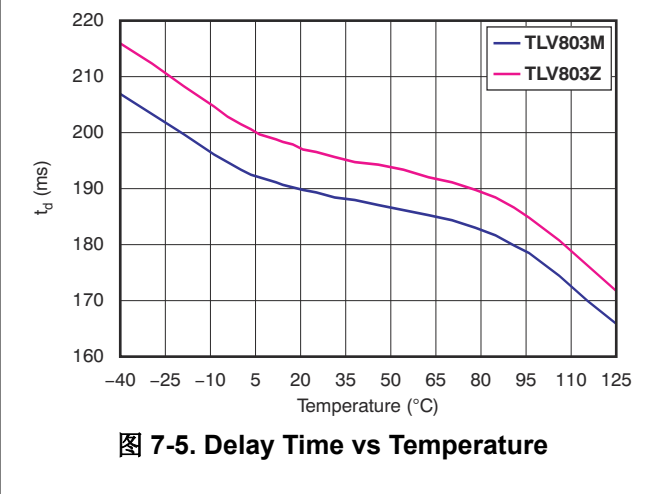
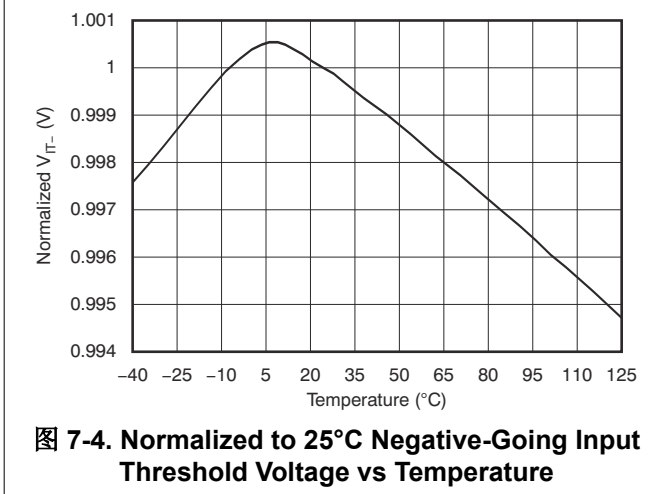
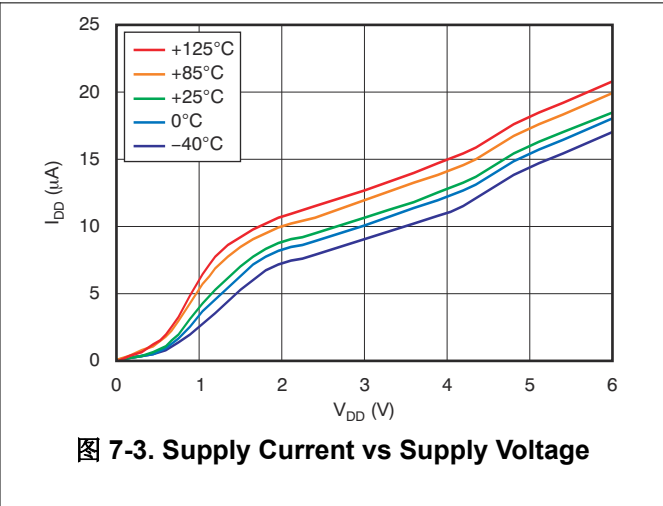
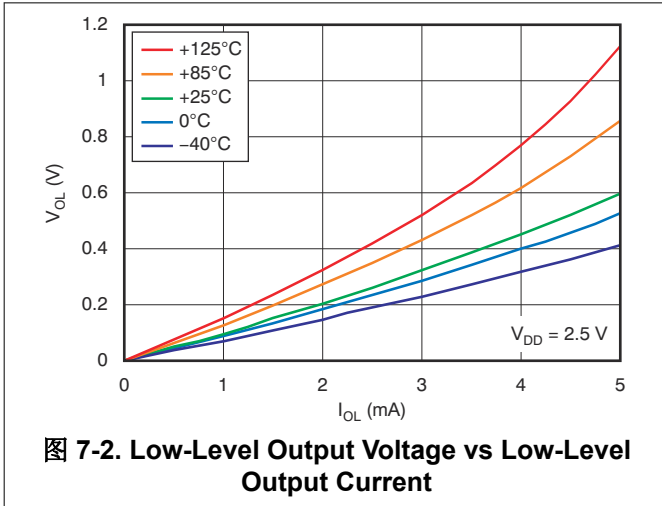

8 Detailed Description

8.1 Overview

The TLV803 family of supervisory circuits provides circuit initialization and timing supervision. The TLV853 and TLV863 are both functionally equivalent to the TLV803. These devices output a logic low whenever V_{DD} drops below the negative-going threshold voltage (V_{IT-}). The output, $\overline{\text{RESET}}$, remains low for approximately 200 ms after the V_{DD} voltage exceeds the positive-going threshold voltage ($V_{IT-} + V_{hys}$). These devices are designed to ignore fast transients on the V_{DD} pin.

8.2 Functional Block Diagram

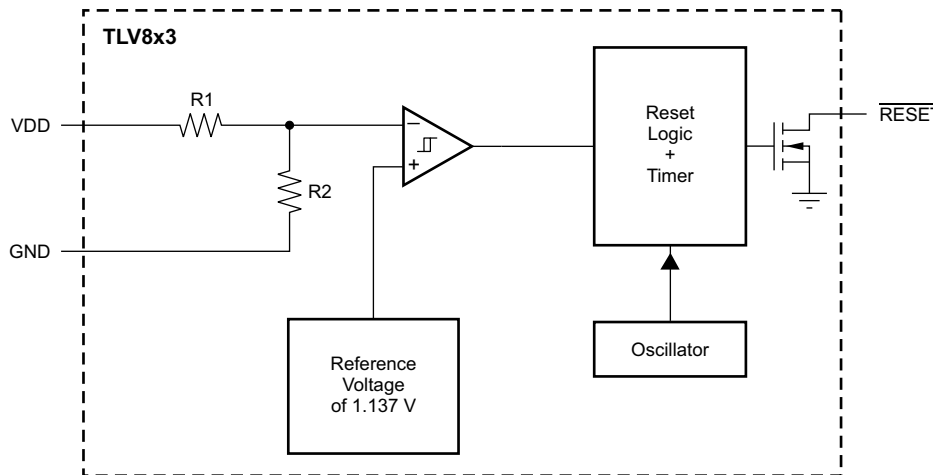

8.3 Feature Description

8.3.1 V_{DD} Transient Rejection

The TLV803 has built-in rejection of fast transients on the V_{DD} pin. The rejection of transients depends on both the duration and the amplitude of the transient. The amplitude of the transient is measured from the bottom of the transient to the negative threshold voltage of the TLV803, as shown in [Figure 8-1](#).



图 8-1. Voltage Transient Measurement

The TLV803 does not respond to transients that are fast duration/low amplitude or long duration/small amplitude. Transients meeting or longer than the t_w specified in the [switching characteristics section](#) triggers a reset.

8.3.2 Reset During Power Up and Power Down

The TLV803 output is valid when V_{DD} is greater than 1.1 V. When V_{DD} is less than 1.1 V, the output transistor turns off and becomes high impedance. The voltage on the $\overline{\text{RESET}}$ pin rises to the voltage level connected to the pull-up resistor. 图 8-2 shows a typical waveform for power-up, assuming the $\overline{\text{RESET}}$ pin has a pull-up resistor connected to the V_{DD} pin.

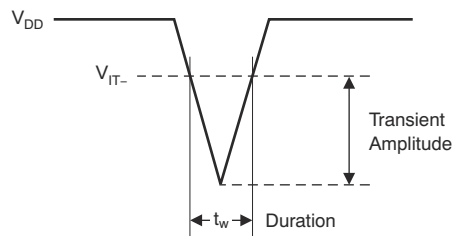

图 8-2. Power-Up Response

8.3.3 Bidirectional Reset Pins

Some microcontrollers have bidirectional reset pins that act as both inputs and outputs. In a situation where the TLV803 is pulling the $\overline{\text{RESET}}$ line low while the microcontroller is trying to force the $\overline{\text{RESET}}$ line high, a series resistor should be placed between the output of the TLV803 and the $\overline{\text{RESET}}$ pin of the microcontroller to protect against excessive current flow. 图 8-3 shows the connection of the TLV803 to a microcontroller using a series resistor to drive a bidirectional $\overline{\text{RESET}}$ line.

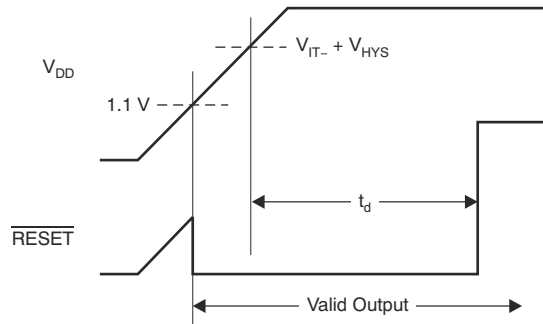

图 8-3. Connection To Bidirectional Reset Pin

8.4 Device Functional Modes

8.4.1 Normal Operation ($V_{DD} >$ Power-Up Reset Voltage)

When the voltage on V_{DD} is greater than 1.1 V, the $\overline{\text{RESET}}$ signal asserts when V_{DD} is less than V_{IT-} and deasserts when V_{DD} is greater than V_{IT-} .

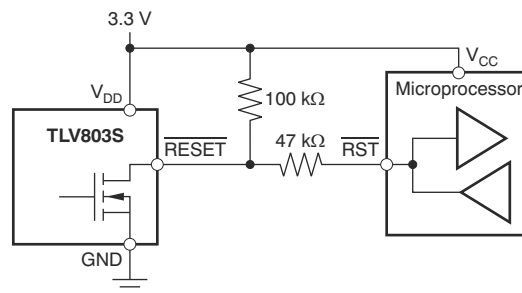
8.4.2 Power On Reset ($V_{DD} <$ Power-Up Reset Voltage)

When the voltage on V_{DD} is lower than the required voltage to internally pull the asserted output to GND (power-up reset voltage), both outputs are in a high-impedance state.

9 Application and Implementation

备注

以下应用部分中的信息不属于 TI 器件规格的范围，TI 不担保其准确性和完整性。TI 的客户应负责确定器件是否适用于其应用。客户应验证并测试其设计，以确保系统功能。

9.1 Application Information

9.1.1 Monitoring Multiple Supplies

Because the TLV803 has an open-drain output, multiple TLV803 outputs can be directly tied together to form a logical OR-ing function for the $\overline{\text{RESET}}$ line. Only one pull-up resistor is required for this configuration. 图 9-1 shows two TLV803s connected together to provide monitoring of a 3.3-V power rail and a 5.0-V power rail. A reset is generated if either power rail falls below the threshold voltage of its corresponding TLV803.



图 9-1. Multiple Voltage Rail Monitoring

9.1.2 Output Level Shifting

The $\overline{\text{RESET}}$ output of the TLV803 can be pulled to a maximum voltage of 6 V and can be pulled higher in voltage than V_{DD} . It is useful to provide level shifting of the output for cases where the monitored voltage is less than the useful logic levels of the load. 图 9-2 shows the TLV803Z used to monitor a 2.5-V power rail, with a logic $\overline{\text{RESET}}$ input to a microprocessor that is connected to 5.0 V and has 5.0-V logic levels.

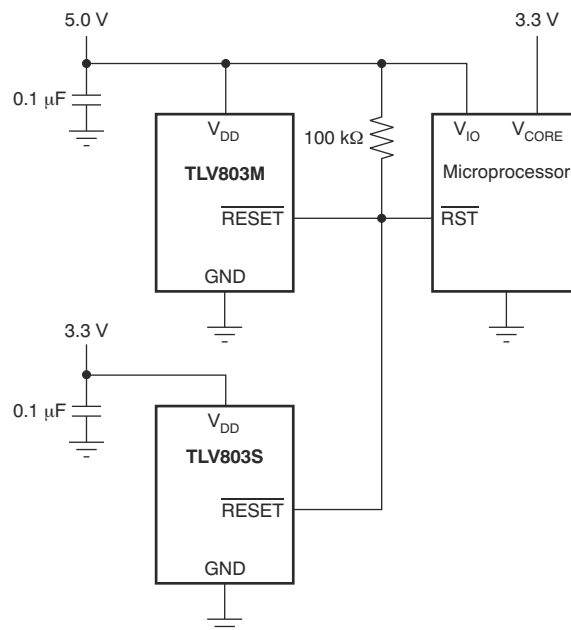

图 9-2. Output Voltage Level Shifting

9.2 Typical Application

图 9-3 shows TLV803S being used to monitor the supply rail for a DSP, FPGA, or ASIC.

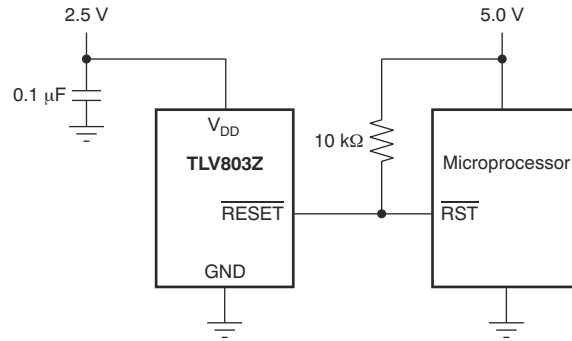

图 9-3. Typical Application

9.2.1 Design Requirements

This design calls for a 3.3-V rail to be monitored. The design resets if the supply rail falls below 2.93 V. The output must satisfy 3.3-V CMOS logic.

9.2.2 Detailed Design Procedure

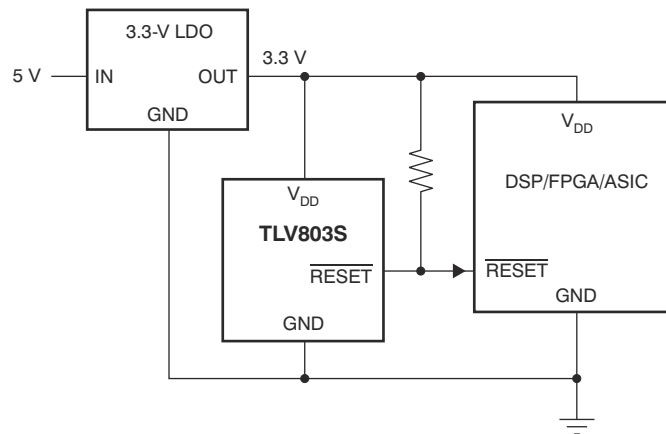
Select the TLV803S to satisfy the voltage threshold requirement.

Place a pullup resistor on $\overline{\text{RESET}}$ to VDD in order to satisfy the output logic requirement.

9.2.3 Application Curves



图 9-4. Low-Level Output Voltage vs Low-Level Output Current

10 Power Supply Recommendations

These devices are designed to operate from an input voltage supply range between 1.1 V and 6 V.

11 Layout

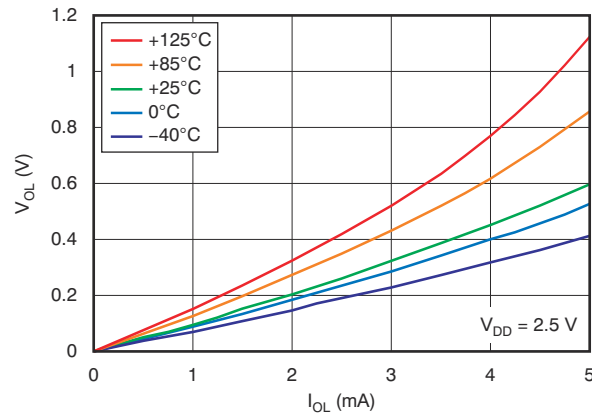
11.1 Layout Guidelines

Place the C_{IN} decoupling capacitor close to the device.

11.2 Layout Example

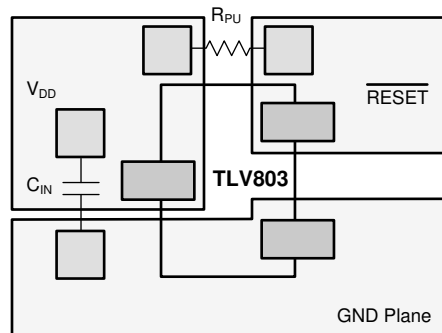

 11-1. Layout Example (DBZ Package)

12 Device and Documentation Support

12.1 Device Support

12.1.1 Development Support

12.1.1.1 Evaluation Modules

An evaluation module (EVM) is available to assist in the initial circuit performance evaluation using the TLV803. The [TLV803SEVM-019 evaluation module](#) (and [related user guide](#)) can be requested at the Texas Instruments website through the product folders or purchased directly [from the TI eStore](#).

12.1.1.2 Spice Models

Computer simulation of circuit performance using SPICE is often useful when analyzing the performance of analog circuits and systems. SPICE models for the TLV803, TLV853, and TLV863 are available through the respective device product folders under *Tools & Software*.

12.2 Documentation Support

12.2.1 Related Documentation

- TLV803SEVM-019 User's Guide. Literature number [SLVU461](#).

12.3 Related Links

表 12-1 lists quick access links. Categories include technical documents, support and community resources, tools and software, and quick access to sample or buy.

表 12-1. Related Links

PARTS	PRODUCT FOLDER	SAMPLE & BUY	TECHNICAL DOCUMENTS	TOOLS & SOFTWARE	SUPPORT & COMMUNITY
TLV803	Click here	Click here	Click here	Click here	Click here
TLV853	Click here	Click here	Click here	Click here	Click here
TLV863	Click here	Click here	Click here	Click here	Click here

12.4 支持资源

TI E2E™ 支持论坛是工程师的重要参考资料，可直接从专家获得快速、经过验证的解答和设计帮助。搜索现有解答或提出自己的问题可获得所需的快速设计帮助。

链接的内容由各个贡献者“按原样”提供。这些内容并不构成 TI 技术规范，并且不一定反映 TI 的观点；请参阅 TI 的《[使用条款](#)》。

12.5 Trademarks

TI E2E™ is a trademark of Texas Instruments.
所有商标均为其各自所有者的财产。

12.6 静电放电警告



静电放电 (ESD) 会损坏这个集成电路。德州仪器 (TI) 建议通过适当的预防措施处理所有集成电路。如果不遵守正确的处理和安装程序，可能会损坏集成电路。

ESD 的损坏小至导致微小的性能降级，大至整个器件故障。精密的集成电路可能更容易受到损坏，这是因为非常细微的参数更改都可能会导致器件与其发布的规格不相符。

12.7 术语表

[TI 术语表](#) 本术语表列出并解释了术语、首字母缩略词和定义。

13 Mechanical, Packaging, and Orderable Information

The following pages include mechanical, packaging, and orderable information. This information is the most current data available for the designated devices. This data is subject to change without notice and revision of this document. For browser-based versions of this data sheet, refer to the left-hand navigation.

PACKAGING INFORMATION

Orderable part number	Status (1)	Material type (2)	Package Pins	Package qty Carrier	RoHS (3)	Lead finish/ Ball material (4)	MSL rating/ Peak reflow (5)	Op temp (°C)	Part marking (6)
TLV803MDBZR	Active	Production	SOT-23 (DBZ) 3	3000 LARGE T&R	Yes	NIPDAU SN NIPDAUAG	Level-1-260C-UNLIM	-40 to 125	VOUQ
TLV803MDBZR.A	Active	Production	SOT-23 (DBZ) 3	3000 LARGE T&R	Yes	NIPDAU	Level-1-260C-UNLIM	-40 to 125	VOUQ
TLV803MDBZT	Active	Production	SOT-23 (DBZ) 3	250 SMALL T&R	Yes	NIPDAU SN NIPDAUAG	Level-1-260C-UNLIM	-40 to 125	VOUQ
TLV803MDBZT.A	Active	Production	SOT-23 (DBZ) 3	250 SMALL T&R	Yes	NIPDAU	Level-1-260C-UNLIM	-40 to 125	VOUQ
TLV803RDBZR	Active	Production	SOT-23 (DBZ) 3	3000 LARGE T&R	Yes	NIPDAU SN NIPDAUAG	Level-1-260C-UNLIM	-40 to 125	VOSQ
TLV803RDBZR.A	Active	Production	SOT-23 (DBZ) 3	3000 LARGE T&R	Yes	NIPDAU	Level-1-260C-UNLIM	-40 to 125	VOSQ
TLV803RDBZRG4	Active	Production	SOT-23 (DBZ) 3	3000 LARGE T&R	Yes	NIPDAU	Level-1-260C-UNLIM	-40 to 125	VOSQ
TLV803RDBZRG4.A	Active	Production	SOT-23 (DBZ) 3	3000 LARGE T&R	Yes	NIPDAU	Level-1-260C-UNLIM	-40 to 125	VOSQ
TLV803RDBZT	Active	Production	SOT-23 (DBZ) 3	250 SMALL T&R	Yes	NIPDAU SN NIPDAUAG	Level-1-260C-UNLIM	-40 to 125	VOSQ
TLV803RDBZT.A	Active	Production	SOT-23 (DBZ) 3	250 SMALL T&R	Yes	NIPDAU	Level-1-260C-UNLIM	-40 to 125	VOSQ
TLV803SDBZR	Active	Production	SOT-23 (DBZ) 3	3000 LARGE T&R	Yes	NIPDAU SN NIPDAUAG	Level-1-260C-UNLIM	-40 to 125	VOTQ
TLV803SDBZR.A	Active	Production	SOT-23 (DBZ) 3	3000 LARGE T&R	Yes	NIPDAU	Level-1-260C-UNLIM	-40 to 125	VOTQ
TLV803SDBZRG4	Active	Production	SOT-23 (DBZ) 3	3000 LARGE T&R	Yes	NIPDAU	Level-1-260C-UNLIM	-40 to 125	VOTQ
TLV803SDBZRG4.A	Active	Production	SOT-23 (DBZ) 3	3000 LARGE T&R	Yes	NIPDAU	Level-1-260C-UNLIM	-40 to 125	VOTQ
TLV803SDBZT	Active	Production	SOT-23 (DBZ) 3	250 SMALL T&R	Yes	NIPDAU SN NIPDAUAG	Level-1-260C-UNLIM	-40 to 125	VOTQ
TLV803SDBZT.A	Active	Production	SOT-23 (DBZ) 3	250 SMALL T&R	Yes	NIPDAU	Level-1-260C-UNLIM	-40 to 125	VOTQ
TLV803ZDBZR	Active	Production	SOT-23 (DBZ) 3	3000 LARGE T&R	Yes	NIPDAU SN NIPDAUAG	Level-1-260C-UNLIM	-40 to 125	VORQ
TLV803ZDBZR.A	Active	Production	SOT-23 (DBZ) 3	3000 LARGE T&R	Yes	NIPDAU	Level-1-260C-UNLIM	-40 to 125	VORQ
TLV803ZDBZT	Active	Production	SOT-23 (DBZ) 3	250 SMALL T&R	Yes	NIPDAU SN NIPDAUAG	Level-1-260C-UNLIM	-40 to 125	VORQ
TLV803ZDBZT.A	Active	Production	SOT-23 (DBZ) 3	250 SMALL T&R	Yes	NIPDAU	Level-1-260C-UNLIM	-40 to 125	VORQ
TLV853MDBZR	Active	Production	SOT-23 (DBZ) 3	3000 LARGE T&R	Yes	NIPDAU SN	Level-1-260C-UNLIM	-40 to 125	ZGM4
TLV853MDBZR.A	Active	Production	SOT-23 (DBZ) 3	3000 LARGE T&R	Yes	NIPDAU	Level-1-260C-UNLIM	-40 to 125	ZGM4
TLV853MDBZT	Active	Production	SOT-23 (DBZ) 3	250 SMALL T&R	Yes	NIPDAU SN	Level-1-260C-UNLIM	-40 to 125	ZGM4

Orderable part number	Status (1)	Material type (2)	Package Pins	Package qty Carrier	RoHS (3)	Lead finish/ Ball material (4)	MSL rating/ Peak reflow (5)	Op temp (°C)	Part marking (6)
TLV853MDBZT.A	Active	Production	SOT-23 (DBZ) 3	250 SMALL T&R	Yes	NIPDAU	Level-1-260C-UNLIM	-40 to 125	ZGM4
TLV863MDBZR	Active	Production	SOT-23 (DBZ) 3	3000 LARGE T&R	Yes	NIPDAU SN NIPDAUAG	Level-1-260C-UNLIM	-40 to 125	VTWM
TLV863MDBZR.A	Active	Production	SOT-23 (DBZ) 3	3000 LARGE T&R	Yes	NIPDAU	Level-1-260C-UNLIM	-40 to 125	VTWM
TLV863MDBZT	Active	Production	SOT-23 (DBZ) 3	250 SMALL T&R	Yes	NIPDAU SN NIPDAUAG	Level-1-260C-UNLIM	-40 to 125	VTWM
TLV863MDBZT.A	Active	Production	SOT-23 (DBZ) 3	250 SMALL T&R	Yes	NIPDAU	Level-1-260C-UNLIM	-40 to 125	VTWM

(1) **Status:** For more details on status, see our [product life cycle](#).

(2) **Material type:** When designated, preproduction parts are prototypes/experimental devices, and are not yet approved or released for full production. Testing and final process, including without limitation quality assurance, reliability performance testing, and/or process qualification, may not yet be complete, and this item is subject to further changes or possible discontinuation. If available for ordering, purchases will be subject to an additional waiver at checkout, and are intended for early internal evaluation purposes only. These items are sold without warranties of any kind.

(3) **RoHS values:** Yes, No, RoHS Exempt. See the [TI RoHS Statement](#) for additional information and value definition.

(4) **Lead finish/Ball material:** Parts may have multiple material finish options. Finish options are separated by a vertical ruled line. Lead finish/Ball material values may wrap to two lines if the finish value exceeds the maximum column width.

(5) **MSL rating/Peak reflow:** The moisture sensitivity level ratings and peak solder (reflow) temperatures. In the event that a part has multiple moisture sensitivity ratings, only the lowest level per JEDEC standards is shown. Refer to the shipping label for the actual reflow temperature that will be used to mount the part to the printed circuit board.

(6) **Part marking:** There may be an additional marking, which relates to the logo, the lot trace code information, or the environmental category of the part.

Multiple part markings will be inside parentheses. Only one part marking contained in parentheses and separated by a "~" will appear on a part. If a line is indented then it is a continuation of the previous line and the two combined represent the entire part marking for that device.

Important Information and Disclaimer: The information provided on this page represents TI's knowledge and belief as of the date that it is provided. TI bases its knowledge and belief on information provided by third parties, and makes no representation or warranty as to the accuracy of such information. Efforts are underway to better integrate information from third parties. TI has taken and continues to take reasonable steps to provide representative and accurate information but may not have conducted destructive testing or chemical analysis on incoming materials and chemicals. TI and TI suppliers consider certain information to be proprietary, and thus CAS numbers and other limited information may not be available for release.

In no event shall TI's liability arising out of such information exceed the total purchase price of the TI part(s) at issue in this document sold by TI to Customer on an annual basis.

TAPE AND REEL INFORMATION

QUADRANT ASSIGNMENTS FOR PIN 1 ORIENTATION IN TAPE

*All dimensions are nominal

Device	Package Type	Package Drawing	Pins	SPQ	Reel Diameter (mm)	Reel Width W1 (mm)	A0 (mm)	B0 (mm)	K0 (mm)	P1 (mm)	W (mm)	Pin1 Quadrant
TLV803MDBZR	SOT-23	DBZ	3	3000	178.0	9.0	3.15	2.77	1.22	4.0	8.0	Q3
TLV803MDBZR	SOT-23	DBZ	3	3000	180.0	8.4	2.9	3.35	1.35	4.0	8.0	Q3
TLV803MDBZT	SOT-23	DBZ	3	250	178.0	9.0	3.15	2.77	1.22	4.0	8.0	Q3
TLV803MDBZT	SOT-23	DBZ	3	250	180.0	8.4	2.9	3.35	1.35	4.0	8.0	Q3
TLV803RDBZR	SOT-23	DBZ	3	3000	180.0	8.4	2.9	3.35	1.35	4.0	8.0	Q3
TLV803RDBZRG4	SOT-23	DBZ	3	3000	180.0	8.4	2.9	3.35	1.35	4.0	8.0	Q3
TLV803RDBZT	SOT-23	DBZ	3	250	180.0	8.4	2.9	3.35	1.35	4.0	8.0	Q3
TLV803RDBZT	SOT-23	DBZ	3	250	178.0	9.0	3.15	2.77	1.22	4.0	8.0	Q3
TLV803SDBZR	SOT-23	DBZ	3	3000	180.0	8.4	2.9	3.35	1.35	4.0	8.0	Q3
TLV803SDBZRG4	SOT-23	DBZ	3	3000	180.0	8.4	2.9	3.35	1.35	4.0	8.0	Q3
TLV803SDBZT	SOT-23	DBZ	3	250	178.0	9.0	3.15	2.77	1.22	4.0	8.0	Q3
TLV803ZDBZR	SOT-23	DBZ	3	3000	180.0	8.4	2.9	3.35	1.35	4.0	8.0	Q3
TLV803ZDBZT	SOT-23	DBZ	3	250	180.0	8.4	2.9	3.35	1.35	4.0	8.0	Q3
TLV803ZDBZT	SOT-23	DBZ	3	250	178.0	9.0	3.15	2.77	1.22	4.0	8.0	Q3
TLV853MDBZR	SOT-23	DBZ	3	3000	180.0	8.4	2.9	3.35	1.35	4.0	8.0	Q3
TLV853MDBZR	SOT-23	DBZ	3	3000	178.0	9.0	3.15	2.77	1.22	4.0	8.0	Q3

Device	Package Type	Package Drawing	Pins	SPQ	Reel Diameter (mm)	Reel Width W1 (mm)	A0 (mm)	B0 (mm)	K0 (mm)	P1 (mm)	W (mm)	Pin1 Quadrant
TLV853MDBZT	SOT-23	DBZ	3	250	180.0	8.4	2.9	3.35	1.35	4.0	8.0	Q3
TLV853MDBZT	SOT-23	DBZ	3	250	178.0	9.0	3.15	2.77	1.22	4.0	8.0	Q3
TLV863MDBZR	SOT-23	DBZ	3	3000	178.0	9.0	3.15	2.77	1.22	4.0	8.0	Q3
TLV863MDBZR	SOT-23	DBZ	3	3000	180.0	8.4	2.9	3.35	1.35	4.0	8.0	Q3
TLV863MDBZT	SOT-23	DBZ	3	250	178.0	9.0	3.15	2.77	1.22	4.0	8.0	Q3
TLV863MDBZT	SOT-23	DBZ	3	250	180.0	8.4	2.9	3.35	1.35	4.0	8.0	Q3

TAPE AND REEL BOX DIMENSIONS



*All dimensions are nominal

Device	Package Type	Package Drawing	Pins	SPQ	Length (mm)	Width (mm)	Height (mm)
TLV803MDBZR	SOT-23	DBZ	3	3000	180.0	180.0	18.0
TLV803MDBZR	SOT-23	DBZ	3	3000	210.0	185.0	35.0
TLV803MDBZT	SOT-23	DBZ	3	250	180.0	180.0	18.0
TLV803MDBZT	SOT-23	DBZ	3	250	210.0	185.0	35.0
TLV803RDBZR	SOT-23	DBZ	3	3000	210.0	185.0	35.0
TLV803RDBZRG4	SOT-23	DBZ	3	3000	210.0	185.0	35.0
TLV803RDBZT	SOT-23	DBZ	3	250	210.0	185.0	35.0
TLV803RDBZT	SOT-23	DBZ	3	250	180.0	180.0	18.0
TLV803SDBZR	SOT-23	DBZ	3	3000	210.0	185.0	35.0
TLV803SDBZRG4	SOT-23	DBZ	3	3000	210.0	185.0	35.0
TLV803SDBZT	SOT-23	DBZ	3	250	180.0	180.0	18.0
TLV803ZDBZR	SOT-23	DBZ	3	3000	210.0	185.0	35.0
TLV803ZDBZT	SOT-23	DBZ	3	250	210.0	185.0	35.0
TLV803ZDBZT	SOT-23	DBZ	3	250	180.0	180.0	18.0
TLV853MDBZR	SOT-23	DBZ	3	3000	210.0	185.0	35.0
TLV853MDBZR	SOT-23	DBZ	3	3000	180.0	180.0	18.0
TLV853MDBZT	SOT-23	DBZ	3	250	210.0	185.0	35.0
TLV853MDBZT	SOT-23	DBZ	3	250	180.0	180.0	18.0

Device	Package Type	Package Drawing	Pins	SPQ	Length (mm)	Width (mm)	Height (mm)
TLV863MDBZR	SOT-23	DBZ	3	3000	180.0	180.0	18.0
TLV863MDBZR	SOT-23	DBZ	3	3000	210.0	185.0	35.0
TLV863MDBZT	SOT-23	DBZ	3	250	180.0	180.0	18.0
TLV863MDBZT	SOT-23	DBZ	3	250	210.0	185.0	35.0

EXAMPLE BOARD LAYOUT

DBZ0003A

SOT-23 - 1.12 mm max height

SMALL OUTLINE TRANSISTOR



LAND PATTERN EXAMPLE
SCALE:15X



SOLDER MASK DETAILS

4214838/F 08/2024

NOTES: (continued)

5. Publication IPC-7351 may have alternate designs.
6. Solder mask tolerances between and around signal pads can vary based on board fabrication site.

EXAMPLE STENCIL DESIGN

DBZ0003A

SOT-23 - 1.12 mm max height

SMALL OUTLINE TRANSISTOR

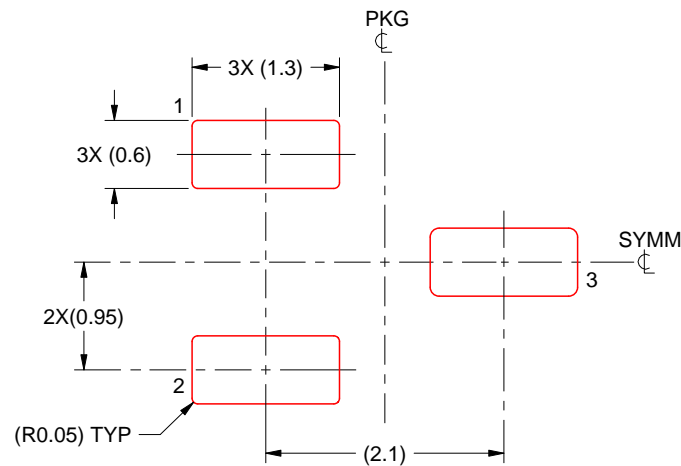

SOLDER PASTE EXAMPLE
BASED ON 0.125 THICK STENCIL
SCALE:15X

4214838/F 08/2024

NOTES: (continued)

7. Laser cutting apertures with trapezoidal walls and rounded corners may offer better paste release. IPC-7525 may have alternate design recommendations.
8. Board assembly site may have different recommendations for stencil design.

重要通知和免责声明

TI“按原样”提供技术和可靠性数据（包括数据表）、设计资源（包括参考设计）、应用或其他设计建议、网络工具、安全信息和其他资源，不保证没有瑕疵且不做任何明示或暗示的担保，包括但不限于对适销性、与某特定用途的适用性或不侵犯任何第三方知识产权的暗示担保。

这些资源可供使用 TI 产品进行设计的熟练开发人员使用。您将自行承担以下全部责任：(1) 针对您的应用选择合适的 TI 产品，(2) 设计、验证并测试您的应用，(3) 确保您的应用满足相应标准以及任何其他安全、安保法规或其他要求。

这些资源如有变更，恕不另行通知。TI 授权您仅可将这些资源用于研发本资源所述的 TI 产品的相关应用。严禁以其他方式对这些资源进行复制或展示。您无权使用任何其他 TI 知识产权或任何第三方知识产权。对于因您对这些资源的使用而对 TI 及其代表造成的任何索赔、损害、成本、损失和债务，您将全额赔偿，TI 对此概不负责。

TI 提供的产品受 [TI 销售条款](#)、[TI 通用质量指南](#) 或 [ti.com](#) 上其他适用条款或 TI 产品随附的其他适用条款的约束。TI 提供这些资源并不会扩展或以其他方式更改 TI 针对 TI 产品发布的适用的担保或担保免责声明。除非德州仪器 (TI) 明确将某产品指定为定制产品或客户特定产品，否则其产品均为按确定价格收入目录的标准通用器件。

TI 反对并拒绝您可能提出的任何其他或不同的条款。

版权所有 © 2026，德州仪器 (TI) 公司

最后更新日期：2025 年 10 月