

TMS320C6418 Fixed-Point Digital Signal Processor

Data Manual

Literature Number: SPRS241D
August 2004 – Revised January 2006

PRODUCTION DATA information is current as of publication date. Products conform to specifications per the terms of Texas Instruments standard warranty. Production processing does not necessarily include testing of all parameters.



This page intentionally left blank

Revision History

This data manual revision history highlights the technical changes made to the SPRS241C device-specific data manual to make it a SPRS241D revision.

Scope: Applicable updates to the C64x device family, specifically relating to the TMS320C6418 device, have been incorporated.

Added the device-specific information supporting the **TMS320C6418** silicon revision 1.1 device, which is now in the production data (**PD**) stage of development (see **ADDS/CHANGES/DELETES**).

| PAGE(s) NO. | ADDS/CHANGES/DELETES |
|----------------|---|
| 15 | Features, 32-Bit External Memory Interface (EMIF) section: Changed "1024M-Byte Total Addressable Memory Space" to "512M-Byte Total Addressable Memory Space" |
| 24 | Functional Overview, Memory Map Summary, TMS320C6418 Memory Map Summary table: Updated Table |
| 47 | Device Configurations, Device Configuration at Device Reset, section: Added Note |
| 48 | Device Configurations, Device Configuration at Device Reset, C6418 Device Configuration Pins (TOUT1/LENDIAN, AEA[22:19], TOUT0/HPI_EN, HD5, CLKINSEL, and OSC_DIS) table: Updated AEA(22:21) Configuration Functional Description for 11 to "EMIFA 8-bit ROM boot" |
| 55 | Device Configurations, Device Status Register Description, Device Status (DEVSTAT) Register Selection Bit Descriptions table: Updated BOOTMODE1 and BOOTMODE0 Description for 11 to "EMIFA 8-bit ROM boot" |
| 57 | Device Configurations, Debugging Considerations section: Deleted paragraphs and added Note |
| 60 | Device Configurations, Terminal Functions, Terminal Functions table, CLOCK/PLL CONFIGURATION section: OSCV _{DD} Signal Name: Changed Description from "Power for crystal oscillator (1.2 V), Do not connect to board power 1.4 V," to "Power for crystal oscillator (1.2 V), Do not connect to board power CV _{DD} ;" |
| 61 | Device Configurations, Terminal Functions, Terminal Functions table, RESETS, INTERRUPTS, AND GENERAL-PURPOSE INPUT/OUTPUTS section, NMI Signal Name: Updated Description |
| 63 | Terminal Functions table, EMIFA (32 BIT) – ADDRESS section: Description for AEA22 to AEA3: Added Note Updated AEA(22:3) Description for Boot mode (AEA[21:22]) – 11 to "EMIFA 8-bit ROM boot" |
| 68 | Terminal Functions table, Supply Voltage Pins section: Updated Description for DV _{DD} |
| 90 | Peripherals Detailed Description, IEEE 1149.1 JTAG Compatibility Statement section: Updated paragraphs for clarity |
| 92 | Device Electrical Specifications, Absolute Maximum Ratings Over Operating Case Temperature Range section: Updated Operating Case Temperature Range, T _C from "-40°C to 105°C" to "0°C to 90°C" Updated Package Temperature Cycling Number of Cycles from "GTS and ZTS" to "GTS and GTSA" |
| 92 | Device Electrical Specifications, Recommended Operating Conditions table: Updated V _{OS} , Maximum voltage during overshoot row Added V _{US} , Minimum voltage during undershoot row |

Revision History

| PAGE(s) NO. | ADDS/CHANGES/DELETES |
|----------------|---|
| 95 | Parameter Measurement Information, AC transient rise/fall time specifications section: Added AC Transient Specification Rise Time figure Added AC Transient Specification Fall Time figure |
| 100 | Peripheral Electrical Specification, Switching Characteristics Over Recommended Operating Conditions for AECLKOUT2 for the EMIFA Module table: Updated Parameter No. 6 from " $t_{d(EKIH-EKO2L)}$ " to " $t_{d(EKIL-EKO2L)}$ " Updated Parameter No. 6 from "Delay time, ECLKIN high to AECLKOUT2 low" to Delay time ECLKIN low to AECLKOUT2 low" |
| 100 | Peripheral Electrical Specification, AECLKOUT2 Timing for the EMIFA Module figure: Updated Figure |
| 116 | Peripheral Electrical Specifications, Reset Timing section: Added Note |
| 121, 122 | MULTICHANNEL AUDIO SERIAL PORT (McASP) TIMING section: Updated McASP Input and Output drawings |

This page intentionally left blank

Contents

| <i>Section</i> | <i>Page</i> |
|---|-------------|
| 1 Features | 15 |
| 2 Functional Overview | 16 |
| 2.1 GTS and ZTS BGA Packages (Bottom View) | 16 |
| 2.2 Description | 17 |
| 2.3 Device Characteristics | 18 |
| 2.3.1 Functional Block Diagram | 19 |
| 2.4 CPU (DSP Core) Description | 20 |
| 2.5 Memory Map Summary | 23 |
| 2.5.1 L2 Architecture Expanded | 25 |
| 2.6 Peripheral Register Descriptions | 26 |
| 2.7 EDMA Channel Synchronization Events | 39 |
| 2.8 Interrupt Sources and Interrupt Selector | 40 |
| 2.9 Signal Groups Description | 42 |
| 3 Device Configurations | 47 |
| 3.1 Device Configuration at Device Reset | 47 |
| 3.2 Peripheral Configuration at Device Reset | 49 |
| 3.3 Peripheral Selection After Device Reset | 50 |
| 3.4 Peripheral Configuration Lock | 52 |
| 3.5 Device Status Register Description | 54 |
| 3.6 JTAG ID Register Description | 55 |
| 3.7 Multiplexed Pins | 56 |
| 3.8 Debugging Considerations | 57 |
| 3.9 Configuration Examples | 57 |
| 3.10 Terminal Functions | 59 |
| 3.11 Development Support | 71 |
| 3.12 Device Support | 72 |
| 3.12.1 Device and Development-Support Tool Nomenclature | 72 |
| 3.12.2 Documentation Support | 74 |

| <i>Section</i> | <i>Page</i> |
|----------------|---|
| 4 | Peripherals Detailed Description (Device-Specific) 75 |
| 4.1 | Clock PLL and Oscillator 75 |
| 4.2 | Host-Port Interface (HPI) Peripheral 79 |
| 4.3 | Multichannel Audio Serial Port (McASP) Peripheral 80 |
| 4.3.1 | McASP Block Diagram 80 |
| 4.4 | I2C 82 |
| 4.5 | Viterbi-Decoder Coprocessor (VCP) 83 |
| 4.6 | General-Purpose Input/Output (GPIO) 83 |
| 4.7 | Power-Down Modes Logic 86 |
| 4.7.1 | Triggering, Wake-up, and Effects 86 |
| 4.7.2 | C64x Power-Down Mode with an Emulator 88 |
| 4.8 | Power-Supply Sequencing 88 |
| 4.8.1 | Power-Supply Design Considerations 88 |
| 4.9 | Power-Supply Decoupling 89 |
| 4.10 | Peripheral Power-Down Operation 89 |
| 4.11 | IEEE 1149.1 JTAG Compatibility Statement 90 |
| 4.12 | EMIF Device Speed 90 |
| 4.13 | Bootmode 91 |
| 4.14 | Reset 91 |
| 5 | Device Electrical Specifications 92 |
| 5.1 | Absolute Maximum Ratings Over Operating Case Temperature Range 92 |
| 5.2 | Recommended Operating Conditions 92 |
| 5.3 | Electrical Characteristics Over Recommended Ranges of Supply Voltage and Operating Case Temperature 93 |
| 5.4 | Recommended Clock and Control Signal Transition Behavior 93 |
| 6 | Parameter Information 94 |
| 6.1 | Signal Transition Levels 94 |
| 6.2 | Signal Transition Rates 94 |
| 6.3 | AC transient rise/fall time specifications 95 |
| 6.4 | Timing Parameters and Board Routing Analysis 96 |

| <i>Section</i> | | <i>Page</i> |
|----------------|--|-------------|
| 7 | Peripheral Electrical Specifications | 97 |
| 7.1 | Input and Output Clocks | 97 |
| 7.2 | Asynchronous Memory Timing | 101 |
| 7.3 | Programmable Synchronous Interface Timing | 104 |
| 7.4 | Synchronous DRAM Timing | 108 |
| 7.5 | HOLD/HOLDA Timing | 114 |
| 7.6 | BUSREQ Timing | 115 |
| 7.7 | Reset Timing | 116 |
| 7.8 | External Interrupt Timing | 119 |
| 7.9 | Multichannel Audio Serial Port (McASP) Timing | 120 |
| 7.10 | Inter-Integrated Circuits (I2C) Timing | 123 |
| 7.11 | Host-Port Interface (HPI) Timing | 125 |
| 7.12 | Multichannel Buffered Serial Port (McBSP) Timing | 130 |
| 7.13 | Timer Timing | 137 |
| 7.14 | General-Purpose Input/Output (GPIO) Port Timing | 138 |
| 7.15 | JTAG Test-Port Timing | 139 |
| | | |
| 8 | Mechanical Data | 140 |
| 8.1 | Thermal Data | 140 |
| 8.2 | Packaging Information | 141 |

List of Figures

| <i>Figure</i> | | <i>Page</i> |
|---------------|---|-------------|
| 2-1 | GTS and ZTS BGA Packages (Bottom View) | 16 |
| 2-2 | Functional Block Diagram | 19 |
| 2-3 | TMS320C64xE CPU (DSP Core) Data Paths | 22 |
| 2-4 | TMS320C6418 L2 Architecture Memory Configuration | 25 |
| 2-5 | CPU and Peripheral Signals | 42 |
| 2-6 | Peripheral Signals | 43 |
| 3-1 | Peripheral Configuration Register (PERCFG) [Address Location: 0x01B3F000] | 50 |
| 3-2 | Peripheral Enable/Disable Flow Diagram | 52 |
| 3-3 | PCFGLOCK Register Diagram [Address Location: 0x01B3 F018] – Read/Write Accesses | 53 |
| 3-4 | Device Status Register (DEVSTAT) Description – 0x01B3 F004 | 54 |
| 3-5 | JTAG ID Register Description – TMS320C6418 Register Value – 0x0007 902F | 55 |
| 3-6 | Configuration Example A (HPI16 + 2 McASPs + 2 McBSPs +2 I2Cs + EMIF + 3 Timers + GPIO) | 58 |
| 3-7 | TMS320C6418 DSP Device Nomenclature | 73 |
| 4-1 | External PLL Circuitry for Either PLL Multiply Modes or x1 (Bypass) Mode | 76 |
| 4-2 | McASP0 and McASP1 Configuration | 81 |
| 4-3 | I2Cx Module Block Diagram | 83 |
| 4-4 | GPIO Enable Register (GPEN) [Hex Address: 01B0 0000] | 84 |
| 4-5 | GPIO Direction Register (GPDIR) [Hex Address: 01B0 0004] | 85 |
| 4-6 | Power-Down Mode Logic | 86 |
| 4-7 | PWRD Field of the CSR Register | 87 |
| 4-8 | Schottky Diode Diagram | 88 |
| 6-1 | Test Load Circuit for AC Timing Measurements | 94 |
| 6-2 | Input and Output Voltage Reference Levels for AC Timing Measurements | 94 |
| 6-3 | Rise and Fall Transition Time Voltage Reference Levels | 94 |
| 6-6 | Board-Level Input/Output Timings | 96 |
| 7-1 | CLKIN Timing | 97 |
| 7-2 | CLKOUT4 Timing | 98 |
| 7-3 | CLKOUT6 Timing | 98 |
| 7-4 | AECLKIN Timing for EMIFA | 99 |
| 7-5 | AECLKOUT1 Timing for the EMIFA Module | 99 |
| 7-6 | AECLKOUT2 Timing for the EMIFA Module | 100 |
| 7-7 | Asynchronous Memory Read Timing for EMIFA | 102 |
| 7-8 | Asynchronous Memory Write Timing for EMIFA | 103 |
| 7-9 | Programmable Synchronous Interface Read Timing for EMIFA (With Read Latency = 2) | 105 |
| 7-10 | Programmable Synchronous Interface Write Timing for EMIFA (With Write Latency = 0) | 106 |
| 7-11 | Programmable Synchronous Interface Write Timing for EMIFA (With Write Latency = 1) | 107 |
| 7-12 | SDRAM Read Command (CAS Latency 3) for EMIFA | 109 |

| <i>Figure</i> | <i>Page</i> |
|---|-------------|
| 7-13 SDRAM Write Command for EMIFA | 110 |
| 7-14 SDRAM ACTV Command for EMIFA | 111 |
| 7-15 SDRAM DCAB Command for EMIFA | 111 |
| 7-16 SDRAM DEAC Command for EMIFA | 112 |
| 7-17 SDRAM REFR Command for EMIFA | 112 |
| 7-18 SDRAM MRS Command for EMIFA | 113 |
| 7-19 SDRAM Self-Refresh Timing for EMIFA | 113 |
| 7-20 HOLD/HOLDA Timing for EMIFA | 114 |
| 7-21 BUSREQ Timing for EMIFA | 115 |
| 7-22 Reset Timing† | 118 |
| 7-23 External/NMI Interrupt Timing | 119 |
| 7-28 I2C Receive Timings | 123 |
| 7-29 I2C Transmit Timings | 124 |
| 7-30 HPI16 Read Timing (HAS Not Used, Tied High) | 126 |
| 7-31 HPI16 Read Timing (HAS Used) | 126 |
| 7-32 HPI16 Write Timing (HAS Not Used, Tied High) | 127 |
| 7-33 HPI16 Write Timing (HAS Used) | 127 |
| 7-34 HPI32 Read Timing (HAS Not Used, Tied High) | 128 |
| 7-35 HPI32 Read Timing (HAS Used) | 128 |
| 7-36 HPI32 Write Timing (HAS Not Used, Tied High) | 129 |
| 7-37 HPI32 Write Timing (HAS Used) | 129 |
| 7-38 McBSP Timing | 132 |
| 7-39 FSR Timing When GSYNC = 1 | 132 |
| 7-40 McBSP Timing as SPI Master or Slave: CLKSTP = 10b, CLKXP = 0 | 133 |
| 7-41 McBSP Timing as SPI Master or Slave: CLKSTP = 11b, CLKXP = 0 | 134 |
| 7-42 McBSP Timing as SPI Master or Slave: CLKSTP = 10b, CLKXP = 1 | 135 |
| 7-43 McBSP Timing as SPI Master or Slave: CLKSTP = 11b, CLKXP = 1 | 136 |
| 7-44 Timer Timing | 137 |
| 7-45 GPIO Port Timing | 138 |
| 7-46 JTAG Test-Port Timing | 139 |

List of Tables

| <i>Table</i> | | <i>Page</i> |
|--------------|---|-------------|
| 2-1 | Characteristics of the C6418 Processor | 18 |
| 2-2 | TMS320C6418 Memory Map Summary | 23 |
| 2-3 | EMIFA Registers | 26 |
| 2-4 | L2 Cache Registers (C64x) | 26 |
| 2-5 | Quick DMA (QDMA) and Pseudo Registers | 29 |
| 2-6 | EDMA Registers (C64x) | 29 |
| 2-7 | EDMA Parameter RAM (C64x)† | 30 |
| 2-8 | Interrupt Selector Registers (C64x) | 31 |
| 2-9 | Device Configuration Registers | 31 |
| 2-10 | McBSP 0 Registers | 32 |
| 2-11 | McBSP 1 Registers | 32 |
| 2-12 | Timer 0 Registers | 33 |
| 2-13 | Timer 1 Registers | 33 |
| 2-14 | Timer 2 Registers | 33 |
| 2-15 | HPI Registers | 34 |
| 2-16 | GP0 Registers | 34 |
| 2-17 | McASP0 and McASP1 Control Registers | 35 |
| 2-18 | McASP0 Data Registers | 37 |
| 2-19 | McASP1 Data Registers | 37 |
| 2-20 | I2C0 and I2C1 Registers | 38 |
| 2-21 | VCP Registers | 38 |
| 2-22 | TMS320C6418 EDMA Channel Synchronization Events | 39 |
| 2-23 | C6418 DSP Interrupts | 41 |
| 3-1 | C6418 Device Configuration Pins (TOUT1/LENDIAN, AEA[22:19], TOUT0/HPI_EN, HD5, CLKINSEL, and OSC_DIS) | 48 |
| 3-2 | TOUT0/HPI_EN and HD5 Peripheral Selection (HPI or McASP1 and Select GP0 Pins) | 49 |
| 3-3 | Peripheral Configuration (PERCFG) Register Selection Bit Descriptions | 51 |
| 3-4 | PCFGLOCK Register Selection Bit Descriptions – Read Accesses | 53 |
| 3-5 | PCFGLOCK Register Selection Bit Descriptions – Write Accesses | 53 |
| 3-6 | Device Status (DEVSTAT) Register Selection Bit Descriptions | 54 |
| 3-7 | JTAG ID Register Selection Bit Descriptions | 55 |
| 3-8 | C6418 Device Multiplexed Pins | 56 |
| 3-9 | Terminal Functions | 60 |
| 4-1 | TMS320C6418 PLL Multiply Factor Options, Clock Frequency Ranges, and Typical Lock Time for –600 Devices | 77 |
| 4-2 | TMS320C6418 PLL Multiply Factor Options, Clock Frequency Ranges, and Typical Lock Time for –500 Devices | 78 |
| 4-3 | Crystal and Tank Circuit Recommendations | 78 |
| 4-4 | Characteristics of the Power-Down Modes | 87 |
| 6-1 | Board-Level Timing Example | 96 |
| 7-1 | Timing Requirements for External Crystal Oscillator Input (OSCIN and OSCOUT) | 97 |
| 7-2 | Timing Requirements for CLKIN | 97 |
| 7-3 | Switching Characteristics Over Recommended Operating Conditions for CLKOUT4 | 98 |
| 7-4 | Switching Characteristics Over Recommended Operating Conditions for CLKOUT6 | 98 |
| 7-5 | Timing Requirements for AECLKIN for EMIFA | 99 |
| 7-6 | Switching Characteristics Over Recommended Operating Conditions for AECLKOUT1 for the EMIFA Module | 99 |

| <i>Table</i> | <i>Page</i> |
|---|-------------|
| 7-7 Switching Characteristics Over Recommended Operating Conditions for AECLKOUT2 for the EMIFA Module | 100 |
| 7-8 Timing Requirements for Asynchronous Memory Cycles for EMIFA Module | 101 |
| 7-9 Switching Characteristics Over Recommended Operating Conditions for Asynchronous Memory Cycles for EMIFA Module | 101 |
| 7-10 Timing Requirements for Programmable Synchronous Interface Cycles for EMIFA Module | 104 |
| 7-11 Switching Characteristics Over Recommended Operating Conditions for Programmable Synchronous Interface Cycles for EMIFA Module | 104 |
| 7-12 Timing Requirements for Synchronous DRAM Cycles for EMIFA Module | 108 |
| 7-13 Switching Characteristics Over Recommended Operating Conditions for Synchronous DRAM Cycles for EMIFA Module | 108 |
| 7-14 Timing Requirements for the $\overline{\text{HOLD}}/\overline{\text{HOLDA}}$ Cycles for EMIFA Module | 114 |
| 7-15 Switching Characteristics Over Recommended Operating Conditions for the $\overline{\text{HOLD}}/\overline{\text{HOLDA}}$ Cycles for EMIFA Module | 114 |
| 7-16 Switching Characteristics Over Recommended Operating Conditions for the BUSREQ Cycles for EMIFA Module | 115 |
| 7-17 Timing Requirements for Reset | 116 |
| 7-18 Switching Characteristics Over Recommended Operating Conditions During Reset | 117 |
| 7-19 Timing Requirements for External Interrupts | 119 |
| 7-20 Timing Requirements for McASP | 120 |
| 7-21 Switching Characteristics Over Recommended Operating Conditions for McASP | 120 |
| 7-22 Timing Requirements for I2C Timings | 123 |
| 7-23 Switching Characteristics for I2C Timings | 124 |
| 7-24 Timing Requirements for Host-Port Interface Cycles | 125 |
| 7-25 Switching Characteristics Over Recommended Operating Conditions During Host-Port Interface Cycles | 125 |
| 7-26 Timing Requirements for McBSP | 130 |
| 7-27 Switching Characteristics Over Recommended Operating Conditions for McBSP | 131 |
| 7-28 Timing Requirements for FSR When GSYNC = 1 | 132 |
| 7-29 Timing Requirements for McBSP as SPI Master or Slave: CLKSTP = 10b, CLKXP = 0 | 133 |
| 7-30 Switching Characteristics Over Recommended Operating Conditions for McBSP as SPI Master or Slave: CLKSTP = 10b, CLKXP = 0 | 133 |
| 7-31 Timing Requirements for McBSP as SPI Master or Slave: CLKSTP = 11b, CLKXP = 0 | 134 |
| 7-32 Switching Characteristics Over Recommended Operating Conditions for McBSP as SPI Master or Slave: CLKSTP = 11b, CLKXP = 0 | 134 |
| 7-33 Timing Requirements for McBSP as SPI Master or Slave: CLKSTP = 10b, CLKXP = 1 | 135 |
| 7-34 Switching Characteristics Over Recommended Operating Conditions for McBSP as SPI Master or Slave: CLKSTP = 10b, CLKXP = 1 | 135 |
| 7-35 Timing Requirements for McBSP as SPI Master or Slave: CLKSTP = 11b, CLKXP = 1 | 136 |
| 7-36 Switching Characteristics Over Recommended Operating Conditions for McBSP as SPI Master or Slave: CLKSTP = 11b, CLKXP = 1 | 136 |
| 7-37 Timing Requirements for Timer Inputs | 137 |
| 7-38 Switching Characteristics Over Recommended Operating Conditions for Timer Outputs | 137 |
| 7-39 Timing Requirements for GPIO Inputs | 138 |
| 7-40 Switching Characteristics Over Recommended Operating Conditions for GPIO Outputs | 138 |
| 7-41 Timing Requirements for JTAG Test Port | 139 |
| 7-42 Switching Characteristics Over Recommended Operating Conditions for JTAG Test Port | 139 |

| <i>Table</i> | | <i>Page</i> |
|--------------|---|-------------|
| 8-1 | Thermal Resistance Characteristics (S-PBGA Package) [GTS] | 140 |
| 8-2 | Thermal Resistance Characteristics (S-PBGA Package) [ZTS] | 140 |

This page intentionally left blank

1 Features

- **High-Performance Fixed-Point Digital Signal Processor (TMS320C6418)**
 - Commercial Temperature Device
 - 1.67-ns Instruction Cycle Time
 - 600-MHz Clock Rate
 - 4800 MIPS
 - Extended Temperature Device
 - 2-ns Instruction Cycle Time
 - 500-MHz Clock Rate
 - 4000 MIPS
 - Eight 32-Bit Instructions/Cycle
 - Fully Software-Compatible With C64x™
- **VelociTI.2™ Extensions to VelociTI™ Advanced Very-Long-Instruction-Word (VLIW) TMS320C64x™ DSP Core**
 - Eight Highly Independent Functional Units With VelociTI.2™ Extensions:
 - Six ALUs (32-/40-Bit), Each Supports Single 32-Bit, Dual 16-Bit, or Quad 8-Bit Arithmetic per Clock Cycle
 - Two Multipliers Support Four 16 x 16-Bit Multiplies (32-Bit Results) per Clock Cycle or Eight 8 x 8-Bit Multiplies (16-Bit Results) per Clock Cycle
 - Load-Store Architecture With Non-Aligned Support
 - 64 32-Bit General-Purpose Registers
 - Instruction Packing Reduces Code Size
 - All Instructions Conditional
- **Instruction Set Features**
 - Byte-Addressable (8-/16-/32-/64-Bit Data)
 - 8-Bit Overflow Protection
 - Bit-Field Extract, Set, Clear
 - Normalization, Saturation, Bit-Counting
 - VelociTI.2™ Increased Orthogonality
- **VelociTI.2™ Extensions to VelociTI™ Advanced Very-Long-Instruction-Word (VLIW) TMS320C64x™ DSP Core**
- **Viterbi Decoder Coprocessor (VCP)**
 - Supports Over 500 7.95-Kbps AMR Voice Channels
 - Programmable Code Parameters
- **L1/L2 Memory Architecture**
 - 128K-Bit (16K-Byte) L1P Program Cache (Direct Mapped)
 - 128K-Bit (16K-Byte) L1D Data Cache (2-Way Set-Associative)
 - 4M-Bit (512K-Byte) L2 Unified Mapped RAM/Cache (Flexible RAM/Cache Allocation)
- **Endianess: Little Endian, Big Endian**
- **32-Bit External Memory Interface (EMIF)**
 - Glueless Interface to Asynchronous Memories (SRAM and EPROM) and Synchronous Memories (SDRAM, SBSRAM, ZBT SRAM, and FIFO)
 - 512M-Byte Total Addressable External Memory Space
- **Enhanced Direct-Memory-Access (EDMA) Controller (64 Independent Channels)**
- **Host-Port Interface (HPI) [32-/16-Bit]**
- **Two Multichannel Audio Serial Ports (McASPs) - with Six Serial Data Pins each**
- **Two Inter-Integrated Circuit (I²C) Buses**
 - Additional GPIO Capability
- **Two Multichannel Buffered Serial Ports**
- **Three 32-Bit General-Purpose Timers**
- **Sixteen General-Purpose I/O (GPIO) Pins**
- **Flexible PLL Clock Generator**
- **On-Chip Fundamental Oscillator**
- **IEEE-1149.1 (JTAG†) Boundary-Scan-Compatible**
- **288-Pin Ball Grid Array (BGA) Package (GTS and ZTS Suffixes), 1.0-mm Ball Pitch**
- **0.13-μm/6-Level Cu Metal Process (CMOS)**
- **3.3-V I/Os, 1.4-V Internal (-600)**
- **3.3-V I/Os, 1.2-V Internal (A-500)**

VelociTI.2, VelociTI, and TMS320C64x are trademarks of Texas Instruments.

All trademarks are the property of their respective owners.

† IEEE Standard 1149.1-1990 Standard-Test-Access Port and Boundary Scan Architecture.

2 Functional Overview

2.1 GTS and ZTS BGA Packages (Bottom View)

GTS and ZTS 288-PIN BALL GRID ARRAY (BGA) PACKAGES
(BOTTOM VIEW)

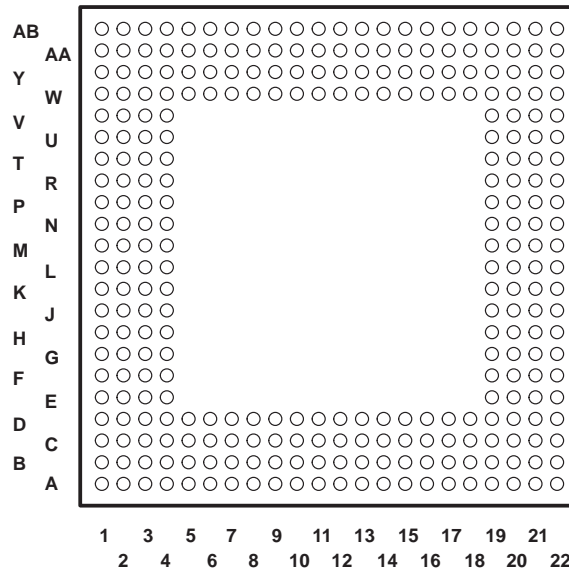

Figure 2-1. GTS and ZTS BGA Packages (Bottom View)

2.2 Description

The TMS320C64x™ DSPs (including the TMS320C6418 device) are the highest-performance fixed-point DSP generation in the TMS320C6000™ DSP platform. The TMS320C6418 (C6418) device is based on the second-generation high-performance, advanced VelociTI™ very-long-instruction-word (VLIW) architecture (VelociTI.2™) developed by Texas Instruments (TI). The high-performance, lower-cost C6418 DSP enables customers to reduce system costs for telecom, software radio, Digital Terrestrial Television Broadcasting (DTTB), and digital Broadcast Satellite/Communication Satellite (BS/CS) applications. The C64x™ is a code-compatible member of the C6000™ DSP platform.

With performance of up to 4800 million instructions per second (MIPS) at a clock rate of 600 MHz, the C6418 device offers cost-effective solutions to high-performance DSP programming challenges. The C6418 DSP possesses the operational flexibility of high-speed controllers and the numerical capability of array processors. The C64x™ DSP core processor has 64 general-purpose registers of 32-bit word length and eight highly independent functional units—two multipliers for a 32-bit result and six arithmetic logic units (ALUs)—with VelociTI.2™ extensions. The VelociTI.2™ extensions in the eight functional units include new instructions to accelerate the performance in video and imaging applications and extend the parallelism of the VelociTI™ architecture. The C6418 can produce four 16-bit multiply-accumulates (MACs) per cycle for a total of 2400 million MACs per second (MMACS), or eight 8-bit MACs per cycle for a total of 4800 MMACS. The C6418 DSP also has application-specific hardware logic, on-chip memory, and additional on-chip peripherals similar to the other C6000™ DSP platform devices.

The C6418 device has a high-performance embedded coprocessor [Viterbi Decoder Coprocessor (VCP)] that significantly speed up channel-decoding operations on-chip. The VCP operating at CPU clock divided-by-4 can decode over 500 7.95-Kbps adaptive multi-rate (AMR) [K = 9, R = 1/3] voice channels. The VCP supports constraint lengths K = 5, 6, 7, 8, and 9, rates R = 1/2, 1/3, and 1/4, and flexible polynomials, while generating hard decisions or soft decisions. Communications between the VCP and the CPU are carried out through the EDMA controller.

The C6418 uses a two-level cache-based architecture and has a powerful and diverse set of peripherals. The Level 1 program cache (L1P) is a 128-Kbit direct mapped cache and the Level 1 data cache (L1D) is a 128-Kbit 2-way set-associative cache. The Level 2 memory/cache (L2) consists of an 4-Mbit memory space that is shared between program and data space. L2 memory can be configured as mapped memory, cache (up to 256K bytes), or combinations of the two. The peripheral set includes: two multichannel buffered audio serial ports (McASPs); two inter-integrated circuit bus modules (I2Cs); two multichannel buffered serial ports (McBSPs); three 32-bit general-purpose timers; a user-configurable 16-bit or 32-bit host-port interface (HPI16/HPI32); a 16-pin general-purpose input/output port (GP0) with programmable interrupt/event generation modes; and a 32-bit glueless external memory interface (EMIFA), which is capable of interfacing to synchronous and asynchronous memories and peripherals.

Each McASP port supports one transmit and one receive clock zone, with six serial data pins which can be individually allocated to any of the two zones. The serial port supports time-division multiplexing on each pin from 2 to 32 time slots. The C6418 has sufficient bandwidth to support all six serial data pins transmitting a 192-kHz stereo signal. Serial data in each zone may be transmitted and received on multiple serial data pins simultaneously and formatted in a multitude of variations on the Philips Inter-IC Sound (I²S) format.

In addition, the McASP transmitter may be programmed to output multiple S/PDIF, IEC60958, AES-3, CP-430 encoded data channels simultaneously, with a single RAM containing the full implementation of user data and channel status fields.

McASP also provides extensive error-checking and recovery features, such as the bad clock detection circuit for each high-frequency master clock which verifies that the master clock is within a programmed frequency range.

The I2C ports on the TMS320C6418 allows the DSP to easily control peripheral devices and communicate with a host processor. In addition, the standard multichannel buffered serial port (McBSP) may be used to communicate with serial peripheral interface (SPI) mode peripheral devices.

TMS320C6000, and C6000 are trademarks of Texas Instruments.

The C6418 has a complete set of development tools which includes: a new C compiler, an assembly optimizer to simplify programming and scheduling, and a Windows™ debugger interface for visibility into source code execution.

2.3 Device Characteristics

Table 2–1, provides an overview of the C6418 DSP. The tables show significant features of the C6418 device, including the capacity of on-chip RAM, the peripherals, the CPU frequency, and the package type with pin count.

Table 2–1. Characteristics of the C6418 Processor

| HARDWARE FEATURES | | C6418 |
|---|---|---|
| Peripherals Not all peripherals pins are available at the same time (For more detail, see the Device Configuration section). | EMIFA (32-bit bus width) (clock source = AECLKIN, CLKOUT4, or CLKOUT6) | 1 |
| | EDMA (64 independent channels) | 1 |
| | McASPs (use Peripheral Clock and AUXCLK) | 2 |
| | I2Cs (use Peripheral Clock) | 2 |
| | HPI (32- or 16-bit user selectable) | 1 (HPI16 or HPI32) |
| | McBSPs (internal clock source = CPU/4 clock frequency) | 2 |
| | 32-Bit Timers (internal clock source = CPU/8 clock frequency) | 3 |
| | General-Purpose Input/Output Port (GP0) | 16 |
| Decoder Coprocessor | VCP (clock source = CPU/2 clock frequency) | 1 |
| On-Chip Memory | Size (Bytes) | 544K |
| | Organization | 16K-Byte (16KB) L1 Program (L1P) Cache 16KB L1 Data (L1D) Cache 512KB Unified Mapped RAM/Cache (L2) |
| CPU ID + CPU Rev ID | Control Status Register (CSR.[31:16]) | 0x0C01 |
| JTAG BSDL_ID | JTAGID register (address location: 0x01B3F008) | 0x0007902F |
| Frequency | MHz | 600 (GTS, ZTS) 500 (GTSA, ZTSA) |
| | | 1.67 ns (GTS, ZTS) [600 MHz CPU, 133 MHz EMIF†] 2 ns (GTSA, ZTSA) [500 MHz CPU, 100 MHz EMIF†] |
| Cycle Time | ns | |
| Voltage | Core (V) | 1.4 V (GTS, ZTS) 1.2v (GTSA, ZTSA) |
| | I/O (V) | 3.3 V |
| PLL Options | CLKIN frequency multiplier | Bypass (x1), x5, x6, x7, x8, x9, x10, x11, x12, x16, x18, x19, x20, x21, x22, and x24 |
| BGA Package | 23 x 23 mm | 288-Pin Flip-Chip Plastic BGA (GTS and ZTS) |
| Process Technology | µm | 0.13 µm |
| Product Status‡ | Product Preview (PP), Advance Information (AI), or Production Data (PD) | PD |

† On this C64x™ device, the rated EMIF speed affects only the SDRAM interface on the EMIF. For more detailed information, see the EMIF device speed portion of this data sheet.

‡ PRODUCTION DATA information is current as of publication date. Products conform to specifications per the terms of Texas Instruments standard warranty. Production processing does not necessarily include testing of all parameters.

2.3.1 Functional Block Diagram

Figure 2–2 shows the functional block diagram of the C6418 device.

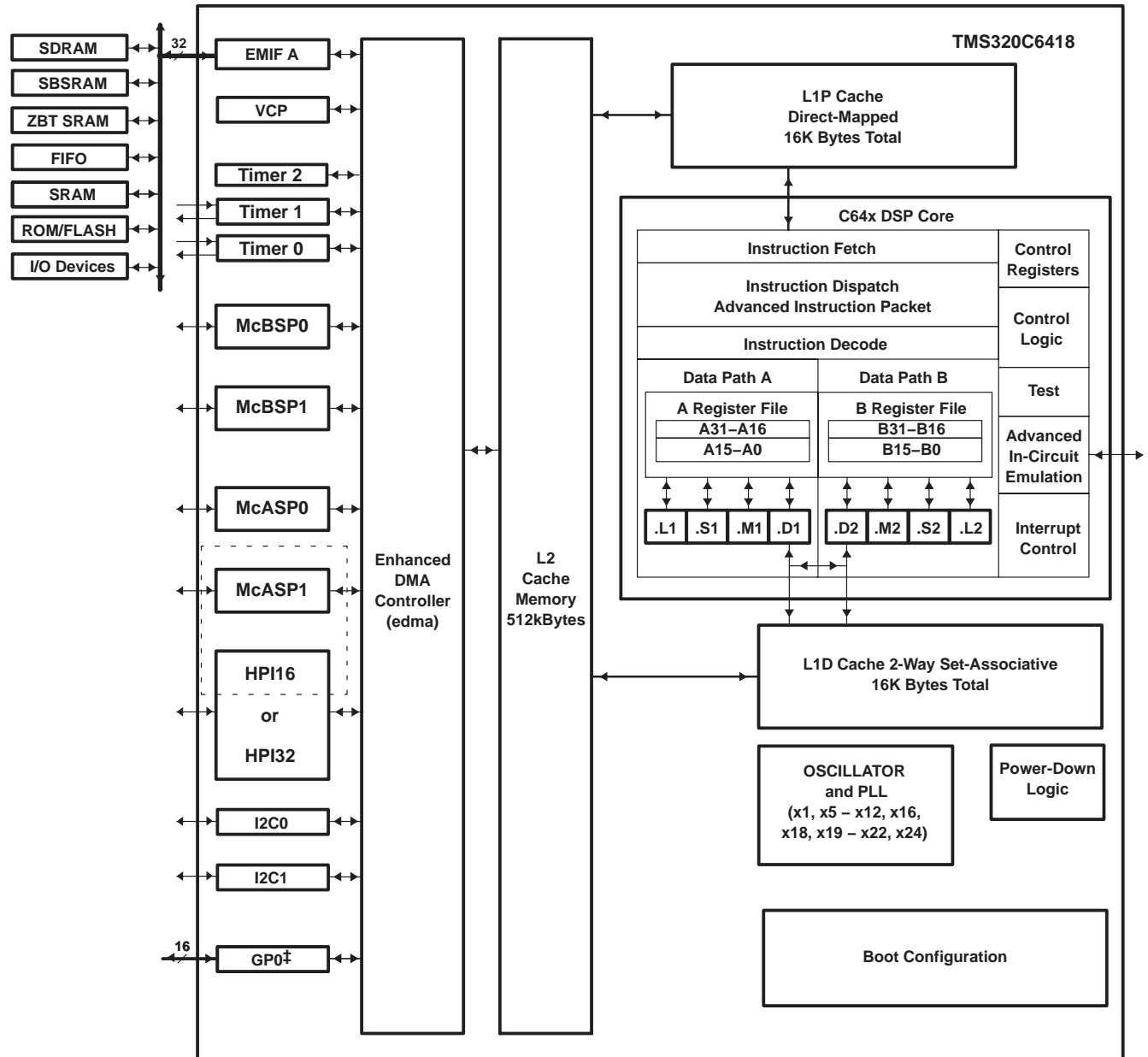

† McBSPs: Framing Chips – H.100, MVIP, SCSA, T1, E1; AC97 Devices; SPI Devices; Codecs

‡ GP0[15:8] pins are muxed with the HPI HD[15:8] pins and GP0[2:1] pins are muxed with CLKOUT6 and CLKOUT4, respectively.

Figure 2–2. Functional Block Diagram

2.4 CPU (DSP Core) Description

The CPU fetches VelociTI™ advanced very-long instruction words (VLIWs) (256 bits wide) to supply up to eight 32-bit instructions to the eight functional units during every clock cycle. The VelociTI™ VLIW architecture features controls by which all eight units do not have to be supplied with instructions if they are not ready to execute. The first bit of every 32-bit instruction determines if the next instruction belongs to the same execute packet as the previous instruction, or whether it should be executed in the following clock as a part of the next execute packet. Fetch packets are always 256 bits wide; however, the execute packets can vary in size. The variable-length execute packets are a key memory-saving feature, distinguishing the C64x CPUs from other VLIW architectures. The C64x™ VelociTI.2™ extensions add enhancements to the TMS320C62x™ DSP VelociTI™ architecture. These enhancements include:

- Register file enhancements
- Data path extensions
- Quad 8-bit and dual 16-bit extensions with data flow enhancements
- Additional functional unit hardware
- Increased orthogonality of the instruction set
- Additional instructions that reduce code size and increase register flexibility

The CPU features two sets of functional units. Each set contains four units and a register file. One set contains functional units .L1, .S1, .M1, and .D1; the other set contains units .D2, .M2, .S2, and .L2. The two register files each contain 32 32-bit registers for a total of 64 general-purpose registers. In addition to supporting the packed 16-bit and 32-/40-bit fixed-point data types found in the C62x™ VelociTI™ VLIW architecture, the C64x™ register files also support packed 8-bit data and 64-bit fixed-point data types. The two sets of functional units, along with two register files, compose sides A and B of the CPU [see the functional block and CPU (DSP core) diagram, and Figure 2–3]. The four functional units on each side of the CPU can freely share the 32 registers belonging to that side. Additionally, each side features a “data cross path”—a single data bus connected to all the registers on the other side, by which the two sets of functional units can access data from the register files on the opposite side. The C64x CPU pipelines data-cross-path accesses over multiple clock cycles. This allows the same register to be used as a data-cross-path operand by multiple functional units in the same execute packet. All functional units in the C64x CPU can access operands via the data cross path. Register access by functional units on the same side of the CPU as the register file can service all the units in a single clock cycle. On the C64x CPU, a delay clock is introduced whenever an instruction attempts to read a register via a data cross path if that register was updated in the previous clock cycle.

In addition to the C62x™ DSP fixed-point instructions, the C64x™ DSP includes a comprehensive collection of quad 8-bit and dual 16-bit instruction set extensions. These VelociTI.2™ extensions allow the C64x CPU to operate directly on packed data to streamline data flow and increase instruction set efficiency.

Another key feature of the C64x CPU is the load/store architecture, where all instructions operate on registers (as opposed to data in memory). Two sets of data-addressing units (.D1 and .D2) are responsible for all data transfers between the register files and the memory. The data address driven by the .D units allows data addresses generated from one register file to be used to load or store data to or from the other register file. The C64x .D units can load and store bytes (8 bits), half-words (16 bits), and words (32 bits) with a single instruction. And with the new data path extensions, the C64x .D unit can load and store doublewords (64 bits) with a single instruction. Furthermore, the non-aligned load and store instructions allow the .D units to access words and doublewords on any byte boundary. The C64x CPU supports a variety of indirect addressing modes using either linear- or circular-addressing with 5- or 15-bit offsets. All instructions are conditional, and most can access any one of the 64 registers. Some registers, however, are singled out to support specific addressing modes or to hold the condition for conditional instructions (if the condition is not automatically “true”).

The two .M functional units perform all multiplication operations. Each of the C64x .M units can perform two 16×16 -bit multiplies or four 8×8 -bit multiplies per clock cycle. The .M unit can also perform 16×32 -bit multiply operations, dual 16×16 -bit multiplies with add/subtract operations, and quad 8×8 -bit multiplies with add operations. In addition to standard multiplies, the C64x .M units include bit-count, rotate, Galois field multiplies, and bidirectional variable shift hardware.

The two .S and .L functional units perform a general set of arithmetic, logical, and branch functions with results available every clock cycle. The arithmetic and logical functions on the C64x CPU include single 32-bit, dual 16-bit, and quad 8-bit operations.

The processing flow begins when a 256-bit-wide instruction fetch packet is fetched from a program memory. The 32-bit instructions destined for the individual functional units are "linked" together by "1" bits in the least significant bit (LSB) position of the instructions. The instructions that are "chained" together for simultaneous execution (up to eight in total) compose an execute packet. A "0" in the LSB of an instruction breaks the chain, effectively placing the instructions that follow it in the next execute packet. A C64x™ DSP device enhancement now allows execute packets to cross fetch-packet boundaries. In the TMS320C62x™/TMS320C67x™ DSP devices, if an execute packet crosses the fetch-packet boundary (256 bits wide), the assembler places it in the next fetch packet, while the remainder of the current fetch packet is padded with NOP instructions. In the C64x™ DSP device, the execute boundary restrictions have been removed, thereby, eliminating all of the NOPs added to pad the fetch packet, and thus, decreasing the overall code size. The number of execute packets within a fetch packet can vary from one to eight. Execute packets are dispatched to their respective functional units at the rate of one per clock cycle and the next 256-bit fetch packet is not fetched until all the execute packets from the current fetch packet have been dispatched. After decoding, the instructions simultaneously drive all active functional units for a maximum execution rate of eight instructions every clock cycle. While most results are stored in 32-bit registers, they can be subsequently moved to memory as bytes, half-words, or doublewords. All load and store instructions are byte-, half-word-, word-, or doubleword-addressable.

For more details on the C64x CPU functional units enhancements, see the following documents:

- *TMS320C6000 CPU and Instruction Set Reference Guide* (literature number SPRU189)
- *TMS320C64x Technical Overview* (literature number SPRU395)

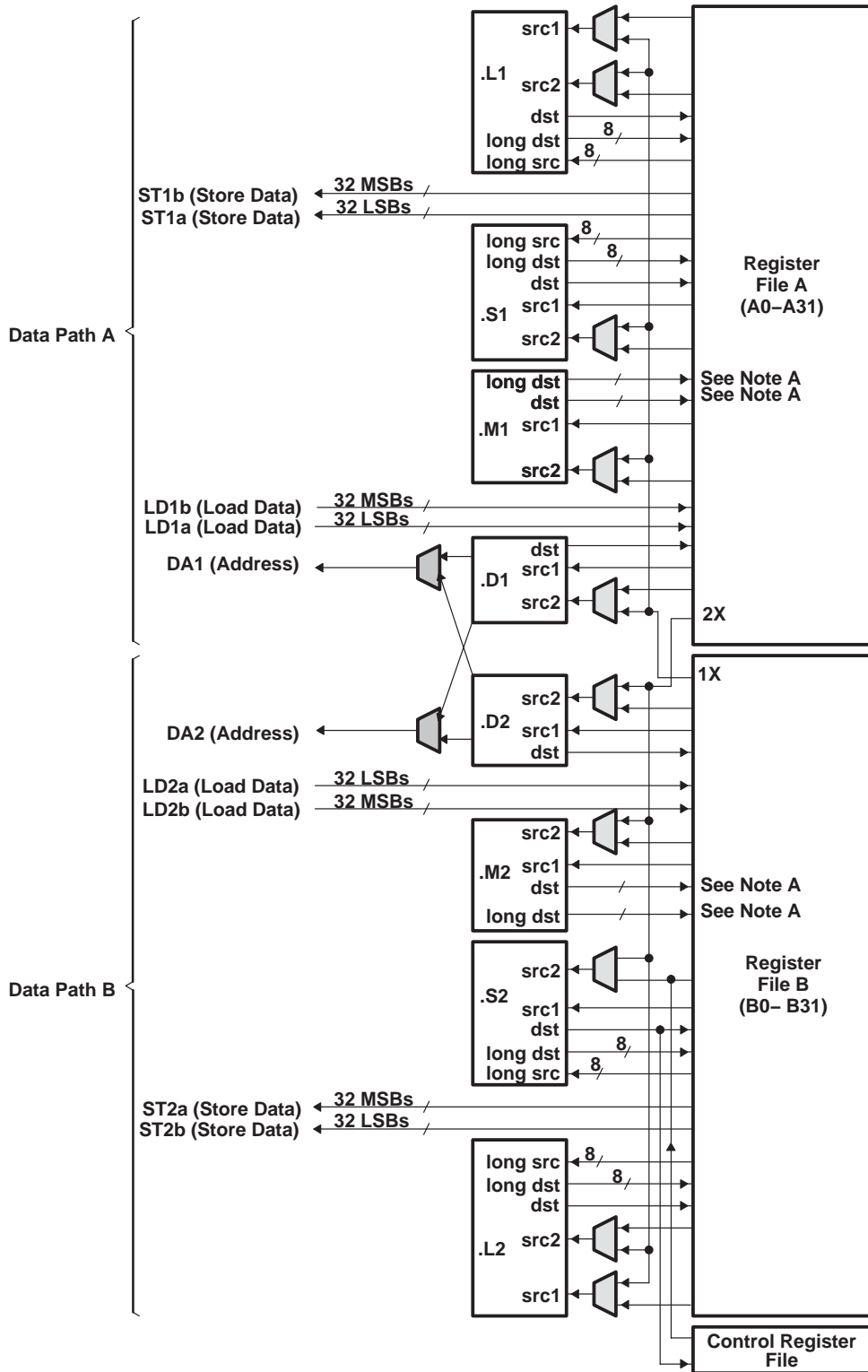

NOTE A: For the .M functional units, the long dst is 32 MSBs and the dst is 32 LSBs.

Figure 2–3. TMS320C64x™ CPU (DSP Core) Data Paths

2.5 Memory Map Summary

Table 2–2 shows the memory map address ranges of the C6418 device. Internal memory is always located at address 0 and can be used as both program and data memory. The external memory address ranges in the C6418 device begin at the hex address location 0x8000 0000 for EMIFA.

Table 2–2. TMS320C6418 Memory Map Summary

| MEMORY BLOCK DESCRIPTION | BLOCK SIZE (BYTES) | HEX ADDRESS RANGE |
|---|--------------------|-----------------------|
| Internal RAM (L2) [C6418] | 512K | 0000 0000 - 0007 FFFF |
| Reserved [C6418] | 512K | 0008 0000 - 000F FFFF |
| Reserved | 15M | 0010 0000 - 00FF FFFF |
| Reserved | 8M | 0100 0000 - 017F FFFF |
| External Memory Interface A (EMIFA) Registers | 256K | 0180 0000 - 0183 FFFF |
| L2 Registers | 256K | 0184 0000 - 0187 FFFF |
| HPI Registers | 256K | 0188 0000 - 018B FFFF |
| McBSP 0 Registers | 256K | 018C 0000 - 018F FFFF |
| McBSP 1 Registers | 256K | 0190 0000 - 0193 FFFF |
| Timer 0 Registers | 256K | 0194 0000 - 0197 FFFF |
| Timer 1 Registers | 256K | 0198 0000 - 019B FFFF |
| Interrupt Selector Registers | 256K | 019C 0000 - 019F FFFF |
| EDMA RAM and EDMA Registers | 256K | 01A0 0000 - 01A3 FFFF |
| Reserved | 512K | 01A4 0000 - 01AB FFFF |
| Timer 2 Registers | 256K | 01AC 0000 - 01AF FFFF |
| GP0 Registers | 256K minus 4K | 01B0 0000 - 01B3 FFFF |
| Device Configuration Registers | 4K | 01B3 F000 - 01B3 FFFF |
| I2C0 Data and Control Registers | 16K | 01B4 0000 - 01B4 3FFF |
| I2C1 Data and Control Registers | 16K | 01B4 4000 - 01B4 7FFF |
| Reserved | 16K | 01B4 8000 - 01B4 BFFF |
| McASP0 Control Registers | 16K | 01B4 C000 - 01B4 FFFF |
| McASP1 Control Registers | 16K | 01B5 0000 - 01B5 3FFF |
| Reserved | 176K | 01B5 4000 - 01B7 FFFF |
| VCP Control Registers | 128K | 01B8 0000 - 01B9 FFFF |
| Reserved | 128K | 01BA 0000 - 01BB FFFF |
| Emulation | 256K | 01BC 0000 - 01BF FFFF |
| Reserved | 528K | 01C0 0000 - 01C8 3FFF |
| Reserved | 3.5M | 01C8 4000 - 01FF FFFF |
| QDMA Registers | 52 | 0200 0000 - 0200 0033 |
| Reserved | 928M minus 52 | 0200 0034 - 2FFF FFFF |
| McBSP 0 Data | 64M | 3000 0000 - 33FF FFFF |
| McBSP 1 Data | 64M | 3400 0000 - 37FF FFFF |
| Reserved | 64M | 3800 0000 - 3BFF FFFF |
| McASP0 Data | 1M | 3C00 0000 - 3C0F FFFF |
| McASP1 Data | 1M | 3C10 0000 - 3C1F FFFF |
| Reserved | 62M | 3C20 0000 - 3FFF FFFF |

Table 2-2. TMS320C6418 Memory Map Summary (Continued)

| MEMORY BLOCK DESCRIPTION | BLOCK SIZE (BYTES) | HEX ADDRESS RANGE |
|--------------------------|--------------------|-----------------------|
| Reserved | 1G | 4000 0000 - 7FFF FFFF |
| EMIFA CE0 | 128M | 8000 0000 - 87FF FFFF |
| Reserved | 128M | 8800 0000 - 8FFF FFFF |
| EMIFA CE1 | 128M | 9000 0000 - 97FF FFFF |
| Reserved | 128M | 9800 0000 - 9FFF FFFF |
| EMIFA CE2 | 128M | A000 0000 - A7FF FFFF |
| Reserved | 128M | A800 0000 - AFFF FFFF |
| EMIFA CE3 | 128M | B000 0000 - B7FF FFFF |
| Reserved | 128M | B800 0000 - BFFF FFFF |
| Reserved | 1G | C000 0000 - FFFF FFFF |

2.5.1 L2 Architecture Expanded

Figure 2–4 shows the detail of the L2 architecture on the TMS320C6418 device. For more information on the L2MODE bits, see the cache configuration (CCFG) register bit field descriptions in the *TMS320C64x Two-Level Internal Memory Reference Guide* (literature number SPRU610).

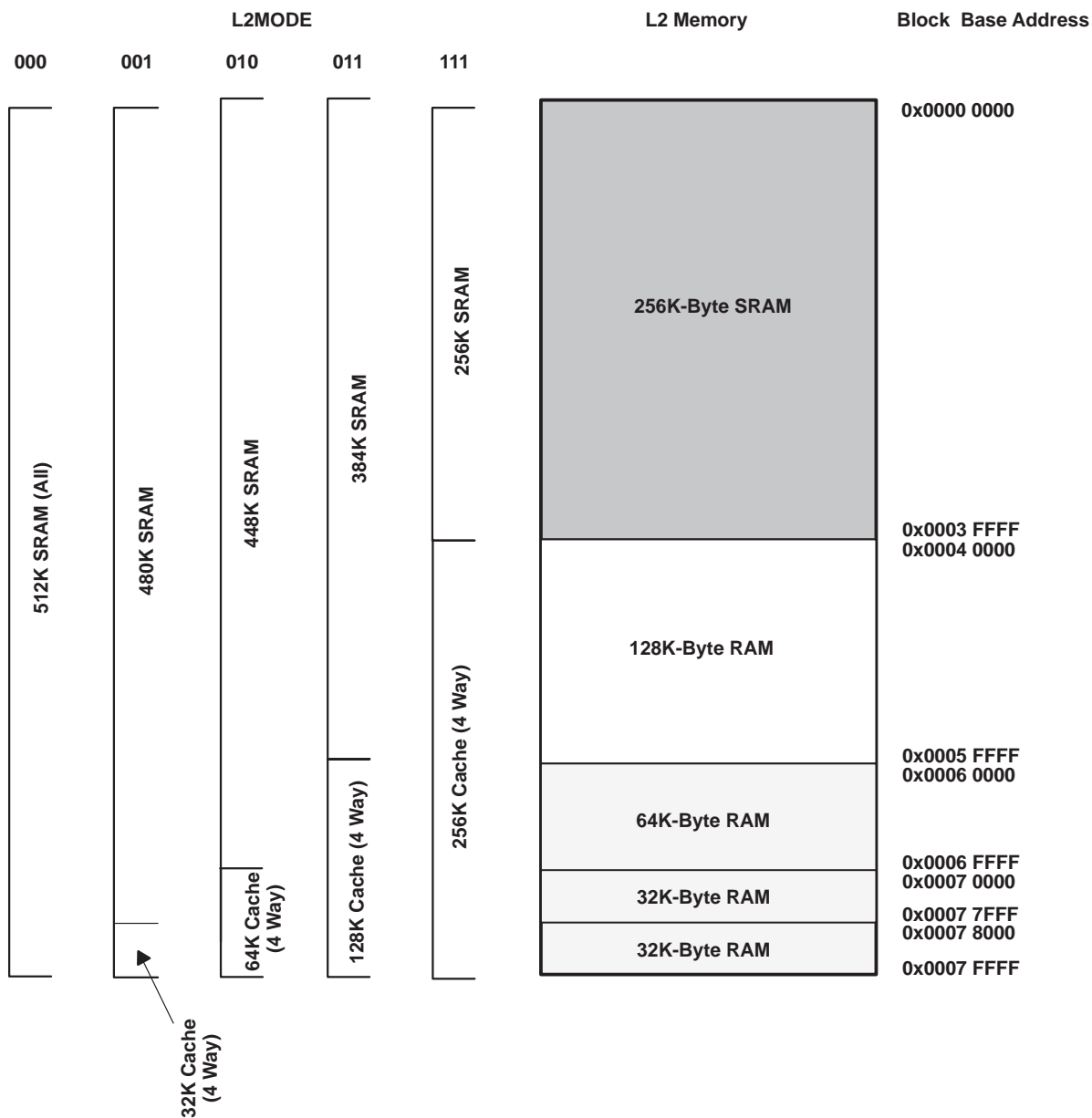

Figure 2–4. TMS320C6418 L2 Architecture Memory Configuration

2.6 Peripheral Register Descriptions

Table 2–3 through Table 2–21 identify the peripheral registers for the C6418 device by their register names, acronyms, and hex address or hex address range. For more detailed information on the register contents, bit names and their descriptions, see the specific peripheral reference guide listed in the *TMS320C6000 DSP Peripherals Overview Reference Guide* (literature number SPRU190).

Table 2–3. EMIFA Registers

| HEX ADDRESS RANGE | ACRONYM | REGISTER NAME | COMMENTS |
|-----------------------|---------|--|----------|
| 0180 0000 | GBLCTL | EMIFA global control | |
| 0180 0004 | CECTL1 | EMIFA CE1 space control | |
| 0180 0008 | CECTL0 | EMIFA CE0 space control | |
| 0180 000C | – | Reserved | |
| 0180 0010 | CECTL2 | EMIFA CE2 space control | |
| 0180 0014 | CECTL3 | EMIFA CE3 space control | |
| 0180 0018 | SDCTL | EMIFA SDRAM control | |
| 0180 001C | SDTIM | EMIFA SDRAM refresh control | |
| 0180 0020 | SDEXT | EMIFA SDRAM extension | |
| 0180 0024 – 0180 003C | – | Reserved | |
| 0180 0040 | PDTCTL | Peripheral device transfer (PDT) control | |
| 0180 0044 | CESEC1 | EMIFA CE1 space secondary control | |
| 0180 0048 | CESEC0 | EMIFA CE0 space secondary control | |
| 0180 004C | – | Reserved | |
| 0180 0050 | CESEC2 | EMIFA CE2 space secondary control | |
| 0180 0054 | CESEC3 | EMIFA CE3 space secondary control | |
| 0180 0058 – 0183 FFFF | – | Reserved | |

Table 2–4. L2 Cache Registers (C64x)

| HEX ADDRESS RANGE | ACRONYM | REGISTER NAME | COMMENTS |
|-----------------------|------------|--|----------|
| 0184 0000 | CCFG | Cache configuration register | |
| 0184 0004 – 0184 0FFC | – | Reserved | |
| 0184 1000 | EDMAWEIGHT | L2 EDMA access control register | |
| 0184 1004 – 0184 1FFC | – | Reserved | |
| 0184 2000 | L2ALLOC0 | L2 allocation register 0 | |
| 0184 2004 | L2ALLOC1 | L2 allocation register 1 | |
| 0184 2008 | L2ALLOC2 | L2 allocation register 2 | |
| 0184 200C | L2ALLOC3 | L2 allocation register 3 | |
| 0184 2010 – 0184 3FFC | – | Reserved | |
| 0184 4000 | L2WBAR | L2 writeback base address register | |
| 0184 4004 | L2WWC | L2 writeback word count register | |
| 0184 4010 | L2WIBAR | L2 writeback invalidate base address register | |
| 0184 4014 | L2WIWC | L2 writeback invalidate word count register | |
| 0184 4018 | L2IBAR | L2 invalidate base address register | |
| 0184 401C | L2IWC | L2 invalidate word count register | |
| 0184 4020 | L1PIBAR | L1P invalidate base address register | |
| 0184 4024 | L1PIWC | L1P invalidate word count register | |
| 0184 4030 | L1DWIBAR | L1D writeback invalidate base address register | |

Table 2–4. L2 Cache Registers (C64x) (Continued)

| HEX ADDRESS RANGE | ACRONYM | REGISTER NAME | COMMENTS |
|-----------------------|----------------|--|----------|
| 0184 4034 | L1DWIWC | L1D writeback invalidate word count register | |
| 0184 4038 – 0184 4044 | – | Reserved | |
| 0184 4048 | L1DIBAR | L1D invalidate base address register | |
| 0184 404C | L1DIWC | L1D invalidate word count register | |
| 0184 4050 – 0184 4FFC | – | Reserved | |
| 0184 5000 | L2WB | L2 writeback all register | |
| 0184 5004 | L2WBINV | L2 writeback invalidate all register | |
| 0184 5008 – 0184 7FFC | – | Reserved | |
| 0184 8000 – 0184 81FC | MAR0 to MAR127 | Reserved | |
| 0184 8200 | MAR128 | Controls EMIFA CE0 range 8000 0000 – 80FF FFFF | |
| 0184 8204 | MAR129 | Controls EMIFA CE0 range 8100 0000 – 81FF FFFF | |
| 0184 8208 | MAR130 | Controls EMIFA CE0 range 8200 0000 – 82FF FFFF | |
| 0184 820C | MAR131 | Controls EMIFA CE0 range 8300 0000 – 83FF FFFF | |
| 0184 8210 | MAR132 | Controls EMIFA CE0 range 8400 0000 – 84FF FFFF | |
| 0184 8214 | MAR133 | Controls EMIFA CE0 range 8500 0000 – 85FF FFFF | |
| 0184 8218 | MAR134 | Controls EMIFA CE0 range 8600 0000 – 86FF FFFF | |
| 0184 821C | MAR135 | Controls EMIFA CE0 range 8700 0000 – 87FF FFFF | |
| 0184 8220 | MAR136 | Controls EMIFA CE0 range 8800 0000 – 88FF FFFF | |
| 0184 8224 | MAR137 | Controls EMIFA CE0 range 8900 0000 – 89FF FFFF | |
| 0184 8228 | MAR138 | Controls EMIFA CE0 range 8A00 0000 – 8AFF FFFF | |
| 0184 822C | MAR139 | Controls EMIFA CE0 range 8B00 0000 – 8BFF FFFF | |
| 0184 8230 | MAR140 | Controls EMIFA CE0 range 8C00 0000 – 8CFF FFFF | |
| 0184 8234 | MAR141 | Controls EMIFA CE0 range 8D00 0000 – 8DFF FFFF | |
| 0184 8238 | MAR142 | Controls EMIFA CE0 range 8E00 0000 – 8EFF FFFF | |
| 0184 823C | MAR143 | Controls EMIFA CE0 range 8F00 0000 – 8FFF FFFF | |
| 0184 8240 | MAR144 | Controls EMIFA CE1 range 9000 0000 – 90FF FFFF | |
| 0184 8244 | MAR145 | Controls EMIFA CE1 range 9100 0000 – 91FF FFFF | |
| 0184 8248 | MAR146 | Controls EMIFA CE1 range 9200 0000 – 92FF FFFF | |
| 0184 824C | MAR147 | Controls EMIFA CE1 range 9300 0000 – 93FF FFFF | |
| 0184 8250 | MAR148 | Controls EMIFA CE1 range 9400 0000 – 94FF FFFF | |
| 0184 8254 | MAR149 | Controls EMIFA CE1 range 9500 0000 – 95FF FFFF | |
| 0184 8258 | MAR150 | Controls EMIFA CE1 range 9600 0000 – 96FF FFFF | |
| 0184 825C | MAR151 | Controls EMIFA CE1 range 9700 0000 – 97FF FFFF | |
| 0184 8260 | MAR152 | Controls EMIFA CE1 range 9800 0000 – 98FF FFFF | |
| 0184 8264 | MAR153 | Controls EMIFA CE1 range 9900 0000 – 99FF FFFF | |
| 0184 8268 | MAR154 | Controls EMIFA CE1 range 9A00 0000 – 9AFF FFFF | |
| 0184 826C | MAR155 | Controls EMIFA CE1 range 9B00 0000 – 9BFF FFFF | |
| 0184 8270 | MAR156 | Controls EMIFA CE1 range 9C00 0000 – 9CFF FFFF | |
| 0184 8274 | MAR157 | Controls EMIFA CE1 range 9D00 0000 – 9DFF FFFF | |
| 0184 8278 | MAR158 | Controls EMIFA CE1 range 9E00 0000 – 9EFF FFFF | |
| 0184 827C | MAR159 | Controls EMIFA CE1 range 9F00 0000 – 9FFF FFFF | |
| 0184 8280 | MAR160 | Controls EMIFA CE2 range A000 0000 – A0FF FFFF | |

Table 2–4. L2 Cache Registers (C64x) (Continued)

| HEX ADDRESS RANGE | ACRONYM | REGISTER NAME | COMMENTS |
|----------------------|---------------------|--|----------|
| 0184 8284 | MAR161 | Controls EMIFA CE2 range A100 0000 – A1FF FFFF | |
| 0184 8288 | MAR162 | Controls EMIFA CE2 range A200 0000 – A2FF FFFF | |
| 0184 828C | MAR163 | Controls EMIFA CE2 range A300 0000 – A3FF FFFF | |
| 0184 8290 | MAR164 | Controls EMIFA CE2 range A400 0000 – A4FF FFFF | |
| 0184 8294 | MAR165 | Controls EMIFA CE2 range A500 0000 – A5FF FFFF | |
| 0184 8298 | MAR166 | Controls EMIFA CE2 range A600 0000 – A6FF FFFF | |
| 0184 829C | MAR167 | Controls EMIFA CE2 range A700 0000 – A7FF FFFF | |
| 0184 82A0 | MAR168 | Controls EMIFA CE2 range A800 0000 – A8FF FFFF | |
| 0184 82A4 | MAR169 | Controls EMIFA CE2 range A900 0000 – A9FF FFFF | |
| 0184 82A8 | MAR170 | Controls EMIFA CE2 range AA00 0000 – AAFF FFFF | |
| 0184 82AC | MAR171 | Controls EMIFA CE2 range AB00 0000 – ABFF FFFF | |
| 0184 82B0 | MAR172 | Controls EMIFA CE2 range AC00 0000 – ACFF FFFF | |
| 0184 82B4 | MAR173 | Controls EMIFA CE2 range AD00 0000 – ADFF FFFF | |
| 0184 82B8 | MAR174 | Controls EMIFA CE2 range AE00 0000 – AEFF FFFF | |
| 0184 82BC | MAR175 | Controls EMIFA CE2 range AF00 0000 – AFFF FFFF | |
| 0184 82C0 | MAR176 | Controls EMIFA CE3 range B000 0000 – B0FF FFFF | |
| 0184 82C4 | MAR177 | Controls EMIFA CE3 range B100 0000 – B1FF FFFF | |
| 0184 82C8 | MAR178 | Controls EMIFA CE3 range B200 0000 – B2FF FFFF | |
| 0184 82CC | MAR179 | Controls EMIFA CE3 range B300 0000 – B3FF FFFF | |
| 0184 82D0 | MAR180 | Controls EMIFA CE3 range B400 0000 – B4FF FFFF | |
| 0184 82D4 | MAR181 | Controls EMIFA CE3 range B500 0000 – B5FF FFFF | |
| 0184 82D8 | MAR182 | Controls EMIFA CE3 range B600 0000 – B6FF FFFF | |
| 0184 82DC | MAR183 | Controls EMIFA CE3 range B700 0000 – B7FF FFFF | |
| 0184 82E0 | MAR184 | Controls EMIFA CE3 range B800 0000 – B8FF FFFF | |
| 0184 82E4 | MAR185 | Controls EMIFA CE3 range B900 0000 – B9FF FFFF | |
| 0184 82E8 | MAR186 | Controls EMIFA CE3 range BA00 0000 – BAFF FFFF | |
| 0184 82EC | MAR187 | Controls EMIFA CE3 range BB00 0000 – BBFF FFFF | |
| 0184 82F0 | MAR188 | Controls EMIFA CE3 range BC00 0000 – BCFF FFFF | |
| 0184 82F4 | MAR189 | Controls EMIFA CE3 range BD00 0000 – BDFF FFFF | |
| 0184 82F8 | MAR190 | Controls EMIFA CE3 range BE00 0000 – BEFF FFFF | |
| 0184 82FC | MAR191 | Controls EMIFA CE3 range BF00 0000 – BFFF FFFF | |
| 0184 8300 –0184 83FC | MAR192 to MAR255 | Reserved | |
| 0184 8400 –0187 FFFF | – | Reserved | |

Table 2–5. Quick DMA (QDMA) and Pseudo Registers

| HEX ADDRESS RANGE | ACRONYM | REGISTER NAME |
|-----------------------|---------|-------------------------------------|
| 0200 0000 | QOPT | QDMA options parameter register |
| 0200 0004 | QSRC | QDMA source address register |
| 0200 0008 | QCNT | QDMA frame count register |
| 0200 000C | QDST | QDMA destination address register |
| 0200 0010 | QIDX | QDMA index register |
| 0200 0014 – 0200 001C | | Reserved |
| 0200 0020 | QSOPT | QDMA pseudo options register |
| 0200 0024 | QSSRC | QDMA psuedo source address register |
| 0200 0028 | QSCNT | QDMA psuedo frame count register |
| 0200 002C | QSDST | QDMA destination address register |
| 0200 0030 | QSIDX | QDMA psuedo index register |

Table 2–6. EDMA Registers (C64x)

| HEX ADDRESS RANGE | ACRONYM | REGISTER NAME |
|-----------------------|---------|---|
| 01A0 0800 – 01A0 FF98 | – | Reserved |
| 01A0 FF9C | EPRH | Event polarity high register |
| 01A0 FFA4 | CIPRH | Channel interrupt pending high register |
| 01A0 FFA8 | CIERH | Channel interrupt enable high register |
| 01A0 FFAC | CCERH | Channel chain enable high register |
| 01A0 FFB0 | ERH | Event high register |
| 01A0 FFB4 | EERH | Event enable high register |
| 01A0 FFB8 | ECRH | Event clear high register |
| 01A0 FFBC | ESRH | Event set high register |
| 01A0 FFC0 | PQAR0 | Priority queue allocation register 0 |
| 01A0 FFC4 | PQAR1 | Priority queue allocation register 1 |
| 01A0 FFC8 | PQAR2 | Priority queue allocation register 2 |
| 01A0 FFCC | PQAR3 | Priority queue allocation register 3 |
| 01A0 FFDC | EPRL | Event polarity low register |
| 01A0 FFE0 | PQSR | Priority queue status register |
| 01A0 FFE4 | CIPRL | Channel interrupt pending low register |
| 01A0 FFE8 | CIERL | Channel interrupt enable low register |
| 01A0 FFEC | CCERL | Channel chain enable low register |
| 01A0 FFF0 | ERL | Event low register |
| 01A0 FFF4 | EERL | Event enable low register |
| 01A0 FFF8 | ECRL | Event clear low register |
| 01A0 FFFC | ESRL | Event set low register |
| 01A1 0000 – 01A3 FFFF | – | Reserved |

Table 2–7. EDMA Parameter RAM (C64x)†

| HEX ADDRESS RANGE | ACRONYM | REGISTER NAME | COMMENTS |
|------------------------|---------|--|--|
| 01A0 0000 – 01A0 0017 | – | Parameters for Event 0 (6 words) | Parameters for Event 0 (6 words) or Reload/Link Parameters for other Event |
| 01A0 0018 – 01A0 002F | – | Parameters for Event 1 (6 words) | |
| 01A0 0030 – 01A0 0047 | – | Parameters for Event 2 (6 words) | |
| 01A0 0048 – 01A0 005F | – | Parameters for Event 3 (6 words) | |
| 01A0 0060 – 01A0 0077 | – | Parameters for Event 4 (6 words) | |
| 01A0 0078 – 01A0 008F | – | Parameters for Event 5 (6 words) | |
| 01A0 0090 – 01A0 00A7 | – | Parameters for Event 6 (6 words) | |
| 01A0 00A8 – 01A0 00BF | – | Parameters for Event 7 (6 words) | |
| 01A0 00C0 – 01A0 00D7 | – | Parameters for Event 8 (6 words) | |
| 01A0 00D8 – 01A0 00EF | – | Parameters for Event 9 (6 words) | |
| 01A0 00F0 – 01A0 00107 | – | Parameters for Event 10 (6 words) | |
| 01A0 0108 – 01A0 011F | – | Parameters for Event 11 (6 words) | |
| 01A0 0120 – 01A0 0137 | – | Parameters for Event 12 (6 words) | |
| 01A0 0138 – 01A0 014F | – | Parameters for Event 13 (6 words) | |
| 01A0 0150 – 01A0 0167 | – | Parameters for Event 14 (6 words) | |
| 01A0 0168 – 01A0 017F | – | Parameters for Event 15 (6 words) | |
| 01A0 0180 – 01A0 0197 | – | Parameters for Event 16 (6 words) | |
| 01A0 0198 – 01A0 01AF | – | Parameters for Event 17 (6 words) | |
| ... | | ... | |
| 01A0 05D0 – 01A0 05E7 | – | Parameters for Event 62 (6 words) | |
| 01A0 05E8 – 01A0 05FF | – | Parameters for Event 63 (6 words) | |
| 01A0 0600 – 01A0 0617 | – | Reload/link parameters for Event 0 (6 words) | Reload/Link Parameters for other Event 0–15 |
| 01A0 0618 – 01A0 062F | – | Reload/link parameters for Event 1 (6 words) | |
| ... | | ... | |
| 01A0 07E0 – 01A0 07F7 | – | Reload/link parameters for Event 20 (6 words) | |
| 01A0 07F8 – 01A0 080F | – | Reload/link parameters for Event 21 (6 words) | |
| 01A0 0810 – 01A0 0827 | – | Reload/link parameters for Event 22 (6 words) | |
| ... | | ... | |
| 01A0 13C8 – 01A0 13DF | – | Reload/link parameters for Event 147 (6 words) | |
| 01A0 13E0 – 01A0 13F7 | – | Reload/link parameters for Event 148 (6 words) | |
| 01A0 13F8 – 01A0 13FF | – | Scratch pad area (2 words) | |
| 01A0 1400 – 01A3 FFFF | – | Reserved | |

† The C6418 device has 213 EDMA parameters total: 64-Event/Reload channels and 149-Reload only parameter sets [six (6) words each] that can be used to reload/link EDMA transfers.

Table 2–8. Interrupt Selector Registers (C64x)

| HEX ADDRESS RANGE | ACRONYM | REGISTER NAME | COMMENTS |
|-----------------------|---------|-----------------------------|---|
| 019C 0000 | MUXH | Interrupt multiplexer high | Selects which interrupts drive CPU interrupts 10–15 (INT10–INT15) |
| 019C 0004 | MUXL | Interrupt multiplexer low | Selects which interrupts drive CPU interrupts 4–9 (INT04–INT09) |
| 019C 0008 | EXTPOL | External interrupt polarity | Sets the polarity of the external interrupts (EXT_INT4–EXT_INT7) |
| 019C 000C – 019F FFFF | – | Reserved | |

Table 2–9. Device Configuration Registers

| HEX ADDRESS RANGE | ACRONYM | REGISTER NAME | COMMENTS |
|-----------------------|----------|--|--|
| 01B3 F000 | PERCFG | Peripheral Configuration Register | Enables or disables specific peripherals. This register is also used for power-down of disabled peripherals. |
| 01B3 F004 | DEVSTAT | Device Status Register | Read-only. Provides status of the User's device configuration on reset. |
| 01B3 F008 | JTAGID | JTAG Identification Register | Read-only. Provides 32-bit JTAG ID of the device. |
| 01B3 F00C – 01B3 F014 | – | Reserved | |
| 01B3 F018 | PCFGLOCK | Peripheral Configuration Lock Register | |
| 01B3 F01C – 01B3 FFFF | – | Reserved | |

Table 2–10. McBSP 0 Registers

| HEX ADDRESS RANGE | ACRONYM | REGISTER NAME | COMMENTS |
|---------------------------|---------|---|---|
| 018C 0000 | DRR0 | McBSP0 data receive register via Configuration Bus | The CPU and EDMA controller can only read this register; they cannot write to it. |
| 0x3000 0000 – 0x33FF FFFF | DRR0 | McBSP0 data receive register via Peripheral Bus | |
| 018C 0004 | DXR0 | McBSP0 data transmit register via Configuration Bus | |
| 0x3000 0000 – 0x33FF FFFF | DXR0 | McBSP0 data transmit register via Peripheral Bus | |
| 018C 0008 | SPCR0 | McBSP0 serial port control register | |
| 018C 000C | RCR0 | McBSP0 receive control register | |
| 018C 0010 | XCR0 | McBSP0 transmit control register | |
| 018C 0014 | SRGR0 | McBSP0 sample rate generator register | |
| 018C 0018 | MCR0 | McBSP0 multichannel control register | |
| 018C 001C | RCERE00 | McBSP0 enhanced receive channel enable register 0 | |
| 018C 0020 | XCERE00 | McBSP0 enhanced transmit channel enable register 0 | |
| 018C 0024 | PCR0 | McBSP0 pin control register | |
| 018C 0028 | RCERE10 | McBSP0 enhanced receive channel enable register 1 | |
| 018C 002C | XCERE10 | McBSP0 enhanced transmit channel enable register 1 | |
| 018C 0030 | RCERE20 | McBSP0 enhanced receive channel enable register 2 | |
| 018C 0034 | XCERE20 | McBSP0 enhanced transmit channel enable register 2 | |
| 018C 0038 | RCERE30 | McBSP0 enhanced receive channel enable register 3 | |
| 018C 003C | XCERE30 | McBSP0 enhanced transmit channel enable register 3 | |
| 018C 0040 – 018F FFFF | – | Reserved | |

Table 2–11. McBSP 1 Registers

| HEX ADDRESS RANGE | ACRONYM | REGISTER NAME | COMMENTS |
|---------------------------|---------|---|---|
| 0190 0000 | DRR1 | McBSP1 data receive register via Configuration Bus | The CPU and EDMA controller can only read this register; they cannot write to it. |
| 0x3400 0000 – 0x37FF FFFF | DRR1 | McBSP1 data receive register via peripheral bus | |
| 0190 0004 | DXR1 | McBSP1 data transmit register via configuration bus | |
| 0x3400 0000 – 0x37FF FFFF | DXR1 | McBSP1 data transmit register via peripheral bus | |
| 0190 0008 | SPCR1 | McBSP1 serial port control register | |
| 0190 000C | RCR1 | McBSP1 receive control register | |
| 0190 0010 | XCR1 | McBSP1 transmit control register | |
| 0190 0014 | SRGR1 | McBSP1 sample rate generator register | |
| 0190 0018 | MCR1 | McBSP1 multichannel control register | |
| 0190 001C | RCERE01 | McBSP1 enhanced receive channel enable register 0 | |
| 0190 0020 | XCERE01 | McBSP1 enhanced transmit channel enable register 0 | |
| 0190 0024 | PCR1 | McBSP1 pin control register | |
| 0190 0028 | RCERE11 | McBSP1 enhanced receive channel enable register 1 | |
| 0190 002C | XCERE11 | McBSP1 enhanced transmit channel enable register 1 | |
| 0190 0030 | RCERE21 | McBSP1 enhanced receive channel enable register 2 | |
| 0190 0034 | XCERE21 | McBSP1 enhanced transmit channel enable register 2 | |
| 0190 0038 | RCERE31 | McBSP1 enhanced receive channel enable register 3 | |
| 0190 003C | XCERE31 | McBSP1 enhanced transmit channel enable register 3 | |
| 0190 0040 – 0193 FFFF | – | Reserved | |

Table 2–12. Timer 0 Registers

| HEX ADDRESS RANGE | ACRONYM | REGISTER NAME | COMMENTS |
|-----------------------|---------|--------------------------|---|
| 0194 0000 | CTL0 | Timer 0 control register | Determines the operating mode of the timer, monitors the timer status, and controls the function of the TOUT pin. |
| 0194 0004 | PRD0 | Timer 0 period register | Contains the number of timer input clock cycles to count. This number controls the TSTAT signal frequency. |
| 0194 0008 | CNT0 | Timer 0 counter register | Contains the current value of the incrementing counter. |
| 0194 000C – 0197 FFFF | – | Reserved | |

Table 2–13. Timer 1 Registers

| HEX ADDRESS RANGE | ACRONYM | REGISTER NAME | COMMENTS |
|-----------------------|---------|--------------------------|---|
| 0198 0000 | CTL1 | Timer 1 control register | Determines the operating mode of the timer, monitors the timer status, and controls the function of the TOUT pin. |
| 0198 0004 | PRD1 | Timer 1 period register | Contains the number of timer input clock cycles to count. This number controls the TSTAT signal frequency. |
| 0198 0008 | CNT1 | Timer 1 counter register | Contains the current value of the incrementing counter. |
| 0198 000C – 019B FFFF | – | Reserved | |

Table 2–14. Timer 2 Registers

| HEX ADDRESS RANGE | ACRONYM | REGISTER NAME | COMMENTS |
|-----------------------|---------|--------------------------|--|
| 01AC 0000 | CTL2 | Timer 2 control register | Determines the operating mode of the timer, monitors the timer status. |
| 01AC 0004 | PRD2 | Timer 2 period register | Contains the number of timer input clock cycles to count. This number controls the TSTAT signal frequency. |
| 01AC 0008 | CNT2 | Timer 2 counter register | Contains the current value of the incrementing counter. |
| 01AC 000C – 01AF FFFF | – | Reserved | |

Table 2–15. HPI Registers

| HEX ADDRESS RANGE | ACRONYM | REGISTER NAME | COMMENTS |
|-----------------------|------------------|---------------------------------------|--|
| – | HPID | HPI data register | Host read/write access only |
| 0188 0000 | HPIC | HPI control register | HPIC has both Host/CPU read/write access |
| 0188 0004 | HPIA (HPIAW)† | HPI address register (Write) | HPIA has both Host/CPU read/write access |
| 0188 0008 | HPIA (HPIAR)† | HPI address register (Read) | |
| 0188 000C – 0189 FFFF | – | Reserved | |
| 018A 0000 | HPI_TRCTL | HPI transfer request control register | |
| 018A 0004 – 018B FFFF | – | Reserved | |

† Host access to the HPIA register updates both the HPIAW and HPIAR registers. The CPU can access HPIAW and HPIAR independently.

Table 2–16. GP0 Registers

| HEX ADDRESS RANGE | ACRONYM | REGISTER NAME |
|-----------------------|---------|---------------------------------|
| 01B0 0000 | GPEN | GP0 enable register |
| 01B0 0004 | GPDIR | GP0 direction register |
| 01B0 0008 | GPVAL | GP0 value register |
| 01B0 000C | – | Reserved |
| 01B0 0010 | GPDH | GP0 delta high register |
| 01B0 0014 | GPHM | GP0 high mask register |
| 01B0 0018 | GDDL | GP0 delta low register |
| 01B0 001C | GPLM | GP0 low mask register |
| 01B0 0020 | GPGC | GP0 global control register |
| 01B0 0024 | GPPOL | GP0 interrupt polarity register |
| 01B0 0028 – 01B3 EFFF | – | Reserved |

Table 2–17. McASP0 and McASP1 Control Registers

| HEX ADDRESS RANGE | | ACRONYM | REGISTER NAME |
|-----------------------|-----------------------|------------|---|
| McASP0 | McASP1 | | |
| 01B4 C000 | 01B5 0000 | PID | Peripheral Identification register [Register value: 0x0010 0101] |
| 01B4 C004 | 01B5 0004 | PWRDEMU | Power down and emulation management register |
| 01B4 C008 | 01B5 0008 | – | Reserved |
| 01B4 C00C | 01B5 000C | – | Reserved |
| 01B4 C010 | 01B5 0010 | PFUNC | Pin function register |
| 01B4 C014 | 01B5 0014 | PDIR | Pin direction register |
| 01B4 C018 | 01B5 0018 | PDOUT | Pin data out register |
| 01B4 C01C | 01B5 001C | PDIN/PDSET | Pin data in / data set register Read returns: PDIN Writes affect: PDSET |
| 01B4 C020 | 01B5 0020 | PDCLR | Pin data clear register |
| 01B4 C024 – 01B4 C040 | 01B5 0024 – 01B5 0040 | – | Reserved |
| 01B4 C044 | 01B5 0044 | GBLCTL | Global control register |
| 01B4 C048 | 01B5 0048 | AMUTE | Mute control register |
| 01B4 C04C | 01B5 004C | DLBCTL | Digital Loop-back control register |
| 01B4 C050 | 01B5 0050 | DITCTL | DIT mode control register |
| 01B4 C054 – 01B4 C05C | 01B5 0054 – 01B5 005C | – | Reserved |
| 01B4 C060 | 01B5 0060 | RGBLCTL | Alias of GBLCTL containing only Receiver Reset bits, allows transmit to be reset independently from receive. |
| 01B4 C064 | 01B5 0064 | RMASK | Receiver format unit bit mask register |
| 01B4 C068 | 01B5 0068 | RFMT | Receive bit stream format register |
| 01B4 C06C | 01B5 006C | AFSRCTL | Receive frame sync control register |
| 01B4 C070 | 01B5 0070 | ACLKRCTL | Receive clock control register |
| 01B4 C074 | 01B5 0074 | AHCLKRCTL | High-frequency receive clock control register |
| 01B4 C078 | 01B5 0078 | RTDM | Receive TDM slot 0–31 register |
| 01B4 C07C | 01B5 007C | RINTCTL | Receiver interrupt control register |
| 01B4 C080 | 01B5 0080 | RSTAT | Status register – Receiver |
| 01B4 C084 | 01B5 0084 | RSLOT | Current receive TDM slot register |
| 01B4 C088 | 01B5 0088 | RCLKCHK | Receiver clock check control register |
| 01B4 C08C – 01B4 C09C | 01B5 008C – 01B5 009C | – | Reserved |
| 01B4 C0A0 | 01B5 00A0 | XGBLCTL | Alias of GBLCTL containing only Transmitter Reset bits, allows transmit to be reset independently from receive. |
| 01B4 C0A4 | 01B5 00A4 | XMASK | Transmit format unit bit mask register |
| 01B4 C0A8 | 01B5 00A8 | XFMT | Transmit bit stream format register |
| 01B4 C0AC | 01B5 00AC | AFSXCTL | Transmit frame sync control register |
| 01B4 C0B0 | 01B5 00B0 | ACLKXCTL | Transmit clock control register |
| 01B4 C0B4 | 01B5 00B4 | AHCLKXCTL | High-frequency Transmit clock control register |
| 01B4 C0B8 | 01B5 00B8 | XTDM | Transmit TDM slot 0–31 register |
| 01B4 C0BC | 01B5 00BC | XINTCTL | Transmit interrupt control register |
| 01B4 C0C0 | 01B5 00C0 | XSTAT | Status register – Transmitter |
| 01B4 C0C4 | 01B5 00C4 | XSLOT | Current transmit TDM slot |
| 01B4 C0C8 | 01B5 00C8 | XCLKCHK | Transmit clock check control register |

Table 2–17. McASP0 and McASP1 Control Registers (Continued)

| HEX ADDRESS RANGE | | ACRONYM | REGISTER NAME |
|-----------------------|-----------------------|----------|---|
| McASP0 | McASP1 | | |
| 01B4 C0CC – 01B4 C0FC | 01B5 00CC – 01B5 00FC | – | Reserved |
| 01B4 C100 | 01B5 0100 | DITCSRA0 | Left (even TDM slot) channel status register file |
| 01B4 C104 | 01B5 0104 | DITCSRA1 | Left (even TDM slot) channel status register file |
| 01B4 C108 | 01B5 0108 | DITCSRA2 | Left (even TDM slot) channel status register file |
| 01B4 C10C | 01B5 010C | DITCSRA3 | Left (even TDM slot) channel status register file |
| 01B4 C110 | 01B5 0110 | DITCSRA4 | Left (even TDM slot) channel status register file |
| 01B4 C114 | 01B5 0114 | DITCSRA5 | Left (even TDM slot) channel status register file |
| 01B4 C118 | 01B5 0118 | DITCSRB0 | Right (odd TDM slot) channel status register file |
| 01B4 C11C | 01B5 011C | DITCSRB1 | Right (odd TDM slot) channel status register file |
| 01B4 C120 | 01B5 0120 | DITCSRB2 | Right (odd TDM slot) channel status register file |
| 01B4 C124 | 01B5 0124 | DITCSRB3 | Right (odd TDM slot) channel status register file |
| 01B4 C128 | 01B5 0128 | DITCSRB4 | Right (odd TDM slot) channel status register file |
| 01B4 C12C | 01B5 012C | DITCSRB5 | Right (odd TDM slot) channel status register file |
| 01B4 C130 | 01B5 0130 | DITUDRA0 | Left (even TDM slot) user data register file |
| 01B4 C134 | 01B5 0134 | DITUDRA1 | Left (even TDM slot) user data register file |
| 01B4 C138 | 01B5 0138 | DITUDRA2 | Left (even TDM slot) user data register file |
| 01B4 C13C | 01B5 013C | DITUDRA3 | Left (even TDM slot) user data register file |
| 01B4 C140 | 01B5 0140 | DITUDRA4 | Left (even TDM slot) user data register file |
| 01B4 C144 | 01B5 0144 | DITUDRA5 | Left (even TDM slot) user data register file |
| 01B4 C148 | 01B5 0148 | DITUDRB0 | Right (odd TDM slot) user data register file |
| 01B4 C14C | 01B5 014C | DITUDRB1 | Right (odd TDM slot) user data register file |
| 01B4 C150 | 01B5 0150 | DITUDRB2 | Right (odd TDM slot) user data register file |
| 01B4 C154 | 01B5 0154 | DITUDRB3 | Right (odd TDM slot) user data register file |
| 01B4 C158 | 01B5 0158 | DITUDRB4 | Right (odd TDM slot) user data register file |
| 01B4 C15C | 01B5 015C | DITUDRB5 | Right (odd TDM slot) user data register file |
| 01B4 C160 – 01B4 C17C | 01B5 0160 – 01B5 017C | – | Reserved |
| 01B4 C180 | 01B5 0180 | SRCTL0 | Serializer 0 control register |
| 01B4 C184 | 01B5 0184 | SRCTL1 | Serializer 1 control register |
| 01B4 C188 | 01B5 0188 | SRCTL2 | Serializer 2 control register |
| 01B4 C18C | 01B5 018C | SRCTL3 | Serializer 3 control register |
| 01B4 C190 | 01B5 0190 | SRCTL4 | Serializer 4 control register |
| 01B4 C194 | 01B5 0194 | SRCTL5 | Serializer 5 control register |
| 01B4 C198 | 01B5 0198 | – | Reserved |
| 01B4 C19C | 01B5 019C | – | Reserved |
| 01B4 C1A0 – 01B4 C1FC | 01B5 01A0 – 01B5 01FC | – | Reserved |
| 01B4 C200 | 01B5 0200 | XBUF0 | Transmit Buffer for Serializer 0 |
| 01B4 C204 | 01B5 0204 | XBUF1 | Transmit Buffer for Serializer 1 |
| 01B4 C208 | 01B5 0208 | XBUF2 | Transmit Buffer for Serializer 2 |
| 01B4 C20C | 01B5 020C | XBUF3 | Transmit Buffer for Serializer 3 |
| 01B4 C210 | 01B5 0210 | XBUF4 | Transmit Buffer for Serializer 4 |
| 01B4 C214 | 01B5 0214 | XBUF5 | Transmit Buffer for Serializer 5 |

Table 2–17. McASP0 and McASP1 Control Registers (Continued)

| HEX ADDRESS RANGE | | ACRONYM | REGISTER NAME |
|-----------------------|-----------------------|---------|---------------------------------|
| McASP0 | McASP1 | | |
| 01B4 C218 | 01B5 0218 | – | Reserved |
| 01B4 C21C | 01B5 021C | – | Reserved |
| 01B4 C220 – 01B4 C27C | 01B5 0220 – 01B5 027C | – | Reserved |
| 01B4 C280 | 01B5 0280 | RBUF0 | Receive Buffer for Serializer 0 |
| 01B4 C284 | 01B5 0284 | RBUF1 | Receive Buffer for Serializer 1 |
| 01B4 C288 | 01B5 0288 | RBUF2 | Receive Buffer for Serializer 2 |
| 01B4 C28C | 01B5 028C | RBUF3 | Receive Buffer for Serializer 3 |
| 01B4 C290 | 01B5 0290 | RBUF4 | Receive Buffer for Serializer 4 |
| 01B4 C294 | 01B5 0294 | RBUF5 | Receive Buffer for Serializer 5 |
| 01B4 C298 | 01B5 0298 | – | Reserved |
| 01B4 C29C | 01B5 029C | – | Reserved |
| 01B4 C2A0 – 01B4 FFFF | 01B5 02A0 – 01B5 3FFF | – | Reserved |

Table 2–18. McASP0 Data Registers

| HEX ADDRESS RANGE | ACRONYM | REGISTER NAME | COMMENTS |
|-----------------------|------------|--|---|
| 3C00 0000 – 3C0F FFFF | RBUF/XBUFx | McASPx receive buffers or McASPx transmit buffers via the Peripheral Data Bus. | (Used when RSEL or XSEL bits = 0 [these bits are located in the RFMT or XFMT registers, respectively].) |

Table 2–19. McASP1 Data Registers

| HEX ADDRESS RANGE | ACRONYM | REGISTER NAME | COMMENTS |
|-----------------------|------------|--|---|
| 3C10 0000 – 3C1F FFFF | RBUF/XBUFx | McASPx receive buffers or McASPx transmit buffers via the Peripheral Data Bus. | (Used when RSEL or XSEL bits = 0 [these bits are located in the RFMT or XFMT registers, respectively].) |

Table 2–20. I2C0 and I2C1 Registers

| HEX ADDRESS RANGE | | ACRONYM | REGISTER NAME |
|-----------------------|-----------------------|------------|---|
| I2C0 | I2C1 | | |
| 01B4 0000 | 01B4 4000 | I2COARx | I2Cx own address register |
| 01B4 0004 | 01B4 4004 | I2CIERx | I2Cx interrupt enable register |
| 01B4 0008 | 01B4 4008 | I2CSTRx | I2Cx interrupt status register |
| 01B4 000C | 01B4 400C | I2CCLKLx | I2Cx clock low-time divider register |
| 01B4 0010 | 01B4 4010 | I2CCLKHx | I2Cx clock high-time divider register |
| 01B4 0014 | 01B4 4014 | I2CCNTx | I2Cx data count register |
| 01B4 0018 | 01B4 4018 | I2CDRRx | I2Cx data receive register |
| 01B4 001C | 01B4 401C | I2CSARx | I2Cx slave address register |
| 01B4 0020 | 01B4 4020 | I2CDXRx | I2Cx data transmit register |
| 01B4 0024 | 01B4 4024 | I2CMDRx | I2Cx mode register |
| 01B4 0028 | 01B4 4028 | I2CISRCx | I2Cx interrupt source register |
| 01B4 002C | 01B4 402C | I2CEMDRx | I2Cx Extended mode register |
| 01B4 0030 | 01B4 4030 | I2CPSCx | I2Cx prescaler register |
| 01B4 0034 | 01B4 4034 | I2CPID1x | I2Cx Peripheral Identification register 1 [Value: 0x0000 0105] |
| 01B4 0038 | 01B4 4038 | I2CPID2x | I2Cx Peripheral Identification register 2 [Value: 0x0000 0005] |
| 01B4 003C – 01B4 0044 | 01B4 403C – 01B4 4044 | – | Reserved |
| 01B4 0048 | 01B4 4048 | I2CPFUNCx | I2Cx pin function register |
| 01B4 004C | 01B4 404C | I2CPDIRx | I2Cx pin direction register |
| 01B4 0050 | 01B4 4050 | I2CPDINx | I2Cx pin data in register |
| 01B4 0054 | 01B4 4054 | I2CPDOUTx | I2Cx pin data out register |
| 01B4 0058 | 01B4 4058 | I2CPDSETx | I2Cx pin data set register |
| 01B4 005C | 01B4 405C | I2CPDCLR x | I2Cx pin data clear register |
| 01B4 0060 – 01B4 3FFF | 01B4 4060 – 01B4 7FFF | – | Reserved |

Table 2–21. VCP Registers

| EDMA BUS HEX ADDRESS RANGE | PERIPHERAL BUS HEX ADDRESS RANGE | ACRONYM | REGISTER NAME |
|-------------------------------|-------------------------------------|----------|------------------------------------|
| 5000 0000 | 01B8 0000 | VCPIC0 | VCP input configuration register 0 |
| 5000 0004 | 01B8 0004 | VCPIC1 | VCP input configuration register 1 |
| 5000 0008 | 01B8 0008 | VCPIC2 | VCP input configuration register 2 |
| 5000 000C | 01B8 000C | VCPIC3 | VCP input configuration register 3 |
| 5000 0010 | 01B8 0010 | VCPIC4 | VCP input configuration register 4 |
| 5000 0014 | 01B8 0014 | VCPIC5 | VCP input configuration register 5 |
| | | | |
| 5000 0040 | 01B8 0024 | VCPOUT0 | VCP output register 0 |
| 5000 0044 | 01B8 0028 | VCPOUT1 | VCP output register 1 |
| | | | |
| 5000 0080 | – | VCPWBM | VCP branch metrics write register |
| 5000 0088 | – | VCPRDECS | VCP decisions read register |
| – | 01B8 0018 | VCPEXE | VCP execution register |
| – | 01B8 0020 | VCPEND | VCP endian register |
| – | 01B8 0040 | VCPSTAT0 | VCP status register 0 |
| – | 01B8 0044 | VCPSTAT1 | VCP status register 1 |
| – | 01B8 0050 | VCPEXR | VCP error register |

2.7 EDMA Channel Synchronization Events

The C64x EDMA supports up to 64 EDMA channels which service peripheral devices and external memory. Table 2–22 lists the source of C64x EDMA synchronization events associated with each of the programmable EDMA channels. For the C6418 device, the association of an event to a channel is fixed; each of the EDMA channels has one specific event associated with it. These specific events are captured in the EDMA event registers (ERL, ERH) even if the events are disabled by the EDMA event enable registers (EERL, EERH). The priority of each event can be specified independently in the transfer parameters stored in the EDMA parameter RAM. For more detailed information on the EDMA module and how EDMA events are enabled, captured, processed, linked, chained, and cleared, etc., see the *TMS320C6000 DSP Enhanced Direct Memory Access (EDMA) Controller Reference Guide* (literature number SPRU234).

Table 2–22. TMS320C6418 EDMA Channel Synchronization Events†

| EDMA CHANNEL | EVENT NAME | EVENT DESCRIPTION |
|--------------|-----------------|--------------------------------------|
| 0 | DSP_INT | HPI-to-DSP interrupt |
| 1 | TINT0 | Timer 0 interrupt |
| 2 | TINT1 | Timer 1 interrupt |
| 3 | SD_INTA | EMIFA SDRAM timer interrupt |
| 4 | GPINT4/EXT_INT4 | GP0 event 4/External interrupt pin 4 |
| 5 | GPINT5/EXT_INT5 | GP0 event 5/External interrupt pin 5 |
| 6 | GPINT6/EXT_INT6 | GP0 event 6/External interrupt pin 6 |
| 7 | GPINT7/EXT_INT7 | GP0 event 7/External interrupt pin 7 |
| 8 | GPINT0 | GP0 event 0 |
| 9 | GPINT1 | GP0 event 1 |
| 10 | GPINT2 | GP0 event 2 |
| 11 | GPINT3 | GP0 event 3 |
| 12 | XEVT0 | McBSP0 transmit event |
| 13 | REVT0 | McBSP0 receive event |
| 14 | XEVT1 | McBSP1 transmit event |
| 15 | REVT1 | McBSP1 receive event |
| 16–18 | – | None |
| 19 | TINT2 | Timer 2 interrupt |
| 20–27 | – | None |
| 28 | VCPREVT | VCP receive event |
| 29 | VCPX EVT | VCP transmit event |
| 30–31 | – | None |
| 32 | AXEVTE0 | McASP0 transmit even event |
| 33 | AXEVTO0 | McASP0 transmit odd event |
| 34 | AXEVT0 | McASP0 transmit event |
| 35 | AREVTE0 | McASP0 receive even event |
| 36 | AREVTO0 | McASP0 receive odd event |
| 37 | AREVT0 | McASP0 receive event |
| 38 | AXEVTE1 | McASP1 transmit even event |
| 39 | AXEVTO1 | McASP1 transmit odd event |
| 40 | AXEVT1 | McASP1 transmit event |

† In addition to the events shown in this table, each of the 64 channels can also be synchronized with the transfer completion or alternate transfer completion events. For more detailed information on EDMA event-transfer chaining, see the *TMS320C6000 DSP Enhanced Direct Memory Access (EDMA) Controller Reference Guide* (literature number SPRU234).

Table 2–22. TMS320C6418 EDMA Channel Synchronization Events† (Continued)

| EDMA CHANNEL | EVENT NAME | EVENT DESCRIPTION |
|--------------|------------|---------------------------|
| 41 | AREVTE1 | McASP1 receive even event |
| 42 | AREVTO1 | McASP1 receive odd event |
| 43 | AREVT1 | McASP1 receive event |
| 44 | ICREVT0 | I2C0 receive event |
| 45 | ICXEVT0 | I2C0 transmit event |
| 46 | ICREVT1 | I2C1 receive event |
| 47 | ICXEVT1 | I2C1 transmit event |
| 48 | GPINT8 | GP0 event 8 |
| 49 | GPINT9 | GP0 event 9 |
| 50 | GPINT10 | GP0 event 10 |
| 51 | GPINT11 | GP0 event 11 |
| 52 | GPINT12 | GP0 event 12 |
| 53 | GPINT13 | GP0 event 13 |
| 54 | GPINT14 | GP0 event 14 |
| 55 | GPINT15 | GP0 event 15 |
| 56–63 | – | None |

† In addition to the events shown in this table, each of the 64 channels can also be synchronized with the transfer completion or alternate transfer completion events. For more detailed information on EDMA event-transfer chaining, see the *TMS320C6000 DSP Enhanced Direct Memory Access (EDMA) Controller Reference Guide* (literature number SPRU234).

2.8 Interrupt Sources and Interrupt Selector

The C64x DSP core supports 16 prioritized interrupts, which are listed in Table 2–23. The highest-priority interrupt is INT_00 (dedicated to RESET) while the lowest-priority interrupt is INT_15. The first four interrupts (INT_00–INT_03) are non-maskable and fixed. The remaining interrupts (INT_04–INT_15) are maskable and default to the interrupt source specified in Table 2–23. The interrupt source for interrupts 4–15 can be programmed by modifying the selector value (binary value) in the corresponding fields of the Interrupt Selector Control registers: MUXH (address 0x019C0000) and MUXL (address 0x019C0004).

Table 2–23. C6418 DSP Interrupts

| CPU INTERRUPT NUMBER | INTERRUPT SELECTOR CONTROL REGISTER | SELECTOR VALUE (BINARY) | INTERRUPT EVENT | INTERRUPT SOURCE |
|----------------------|-------------------------------------|-------------------------|-----------------|--|
| INT_00† | – | – | RESET | |
| INT_01† | – | – | NMI | |
| INT_02† | – | – | Reserved | Reserved. Do not use. |
| INT_03† | – | – | Reserved | Reserved. Do not use. |
| INT_04‡ | MUXL[4:0] | 00100 | GPINT4/EXT_INT4 | GP0 interrupt 4/External interrupt pin 4 |
| INT_05‡ | MUXL[9:5] | 00101 | GPINT5/EXT_INT5 | GP0 interrupt 5/External interrupt pin 5 |
| INT_06‡ | MUXL[14:10] | 00110 | GPINT6/EXT_INT6 | GP0 interrupt 6/External interrupt pin 6 |
| INT_07‡ | MUXL[20:16] | 00111 | GPINT7/EXT_INT7 | GP0 interrupt 7/External interrupt pin 7 |
| INT_08‡ | MUXL[25:21] | 01000 | EDMA_INT | EDMA channel (0 through 63) interrupt |
| INT_09‡ | MUXL[30:26] | 01001 | EMU_DTDMA | EMU DTDMA |
| INT_10‡ | MUXH[4:0] | 00011 | SD_INTA | EMIFA SDRAM timer interrupt |
| INT_11‡ | MUXH[9:5] | 01010 | EMU_RTDXR | EMU real-time data exchange (RTDX) receive |
| INT_12‡ | MUXH[14:10] | 01011 | EMU_RTDXT | EMU RTDX transmit |
| INT_13‡ | MUXH[20:16] | 00000 | DSP_INT | HPI-to-DSP interrupt |
| INT_14‡ | MUXH[25:21] | 00001 | TINT0 | Timer 0 interrupt |
| INT_15‡ | MUXH[30:26] | 00010 | TINT1 | Timer 1 interrupt |
| – | – | 01100 | XINT0 | McBSP0 transmit interrupt |
| – | – | 01101 | RINT0 | McBSP0 receive interrupt |
| – | – | 01110 | XINT1 | McBSP1 transmit interrupt |
| – | – | 01111 | RINT1 | McBSP1 receive interrupt |
| – | – | 10000 | GPINT0 | GP0 interrupt 0 |
| – | – | 10001 | Reserved | Reserved. Do not use. |
| – | – | 10010 | Reserved | Reserved. Do not use. |
| – | – | 10011 | TINT2 | Timer 2 interrupt |
| – | – | 10100 | Reserved | Reserved. Do not use. |
| – | – | 10101 | Reserved | Reserved. Do not use. |
| – | – | 10110 | ICINT0 | I2C0 interrupt |
| – | – | 10111 | ICINT1 | I2C1 interrupt |
| – | – | 11000 | AXINT1 | McASP1 transmit interrupt |
| – | – | 11001 | ARINT1 | McASP1 receive interrupt |
| – | – | 11010 | Reserved | Reserved. Do not use. |
| – | – | 11011 | Reserved | Reserved. Do not use. |
| – | – | 11100 | AXINT0 | McASP0 transmit interrupt |
| – | – | 11101 | ARINT0 | McASP0 receive interrupt |
| – | – | 11110 | VCPINT | VCP interrupt |
| – | – | 11111 | Reserved | Reserved. Do not use. |

† Interrupts INT_00 through INT_03 are non-maskable and fixed.

‡ Interrupts INT_04 through INT_15 are programmable by modifying the binary selector values in the Interrupt Selector Control registers fields.

Table 2–23 shows the default interrupt sources for Interrupts INT_04 through INT_15. For more detailed information on interrupt sources and selection, see the *TMS320C6000 DSP Interrupt Selector Reference Guide* (literature number SPRU646).

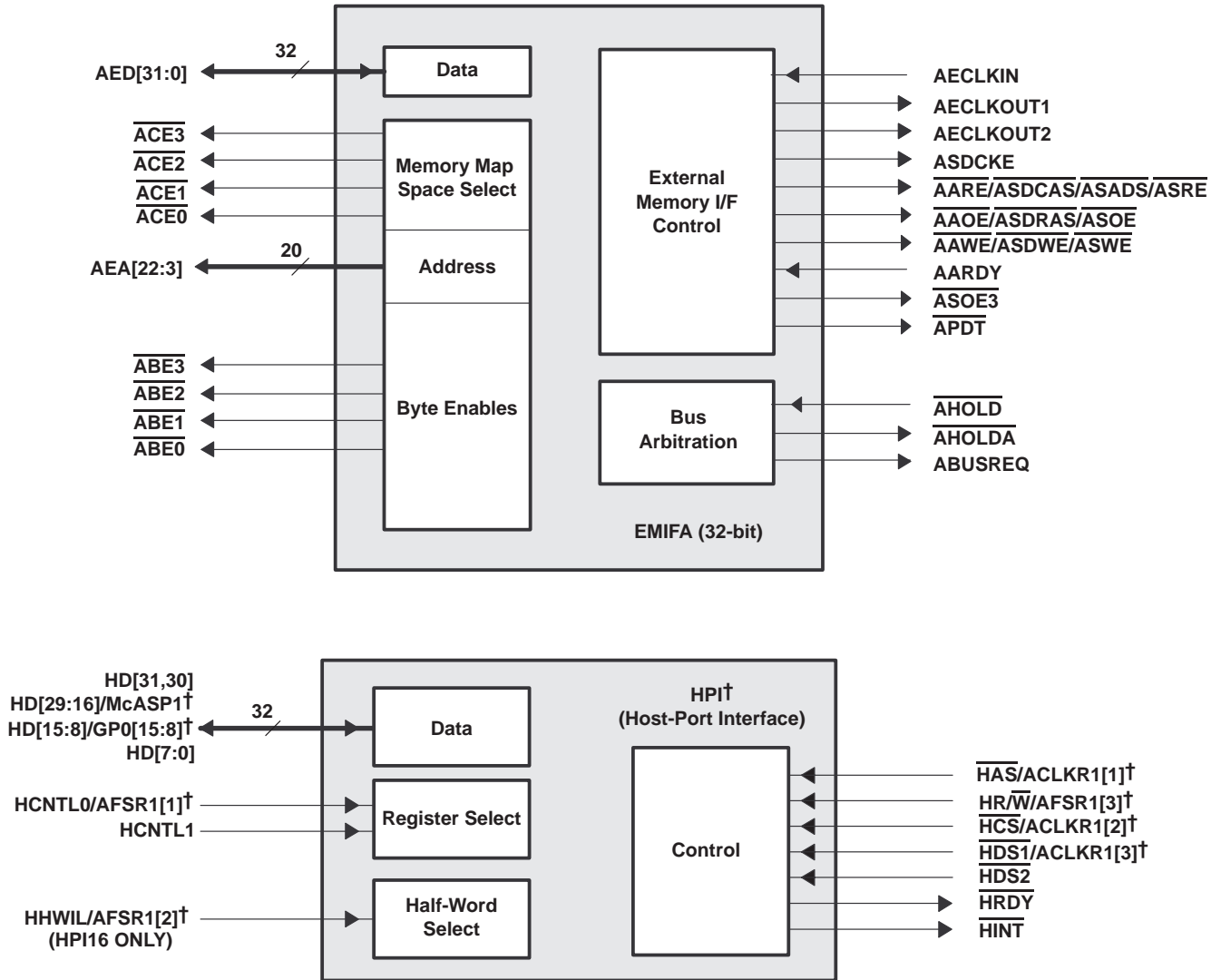

† These HPI pins are muxed with the McASP1 or GP0 peripherals. By default, these signals function as HPI and no function, respectively. For more details on these muxed pins, see the Device Configurations section of this data sheet.

Figure 2-6. Peripheral Signals

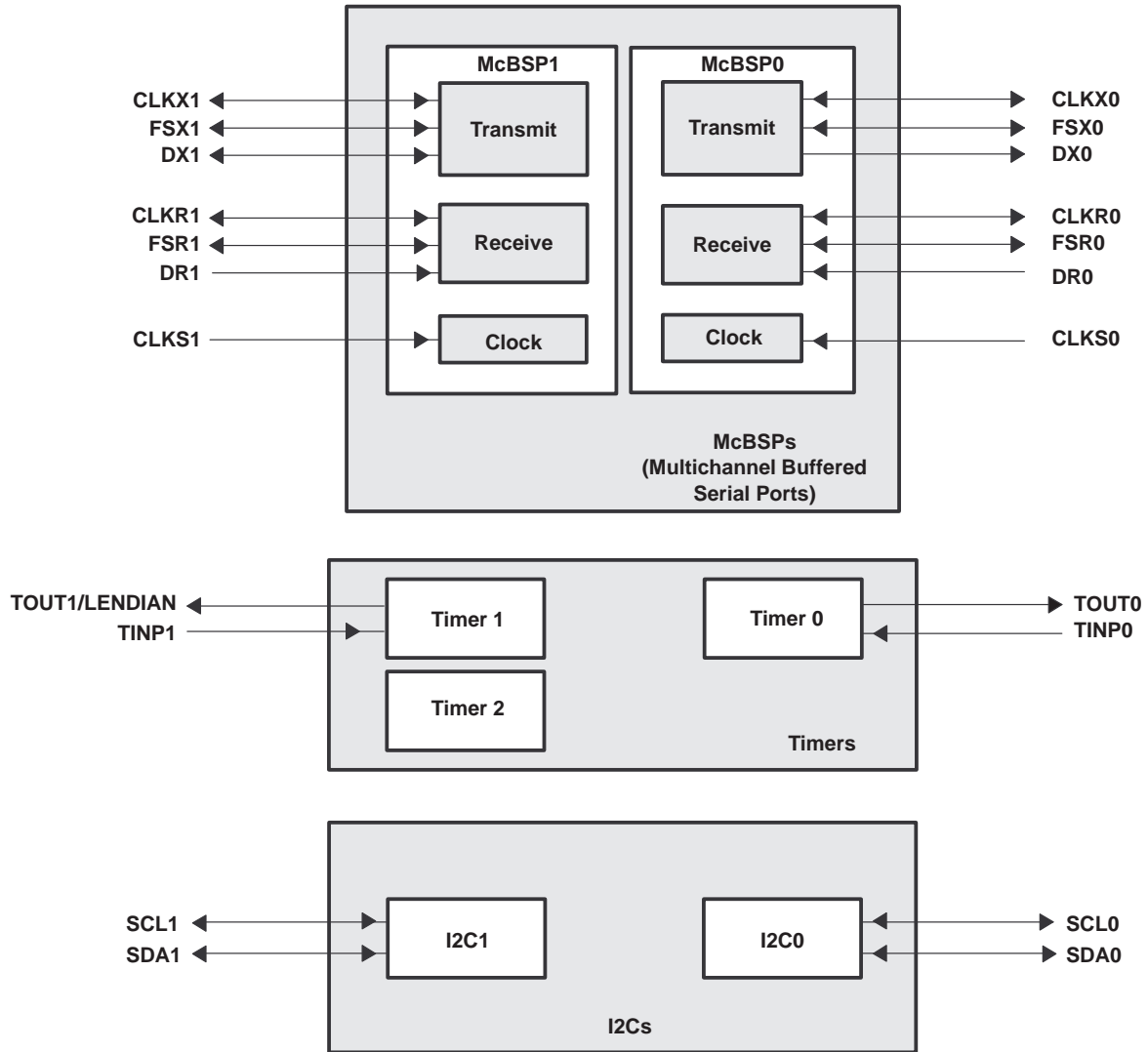
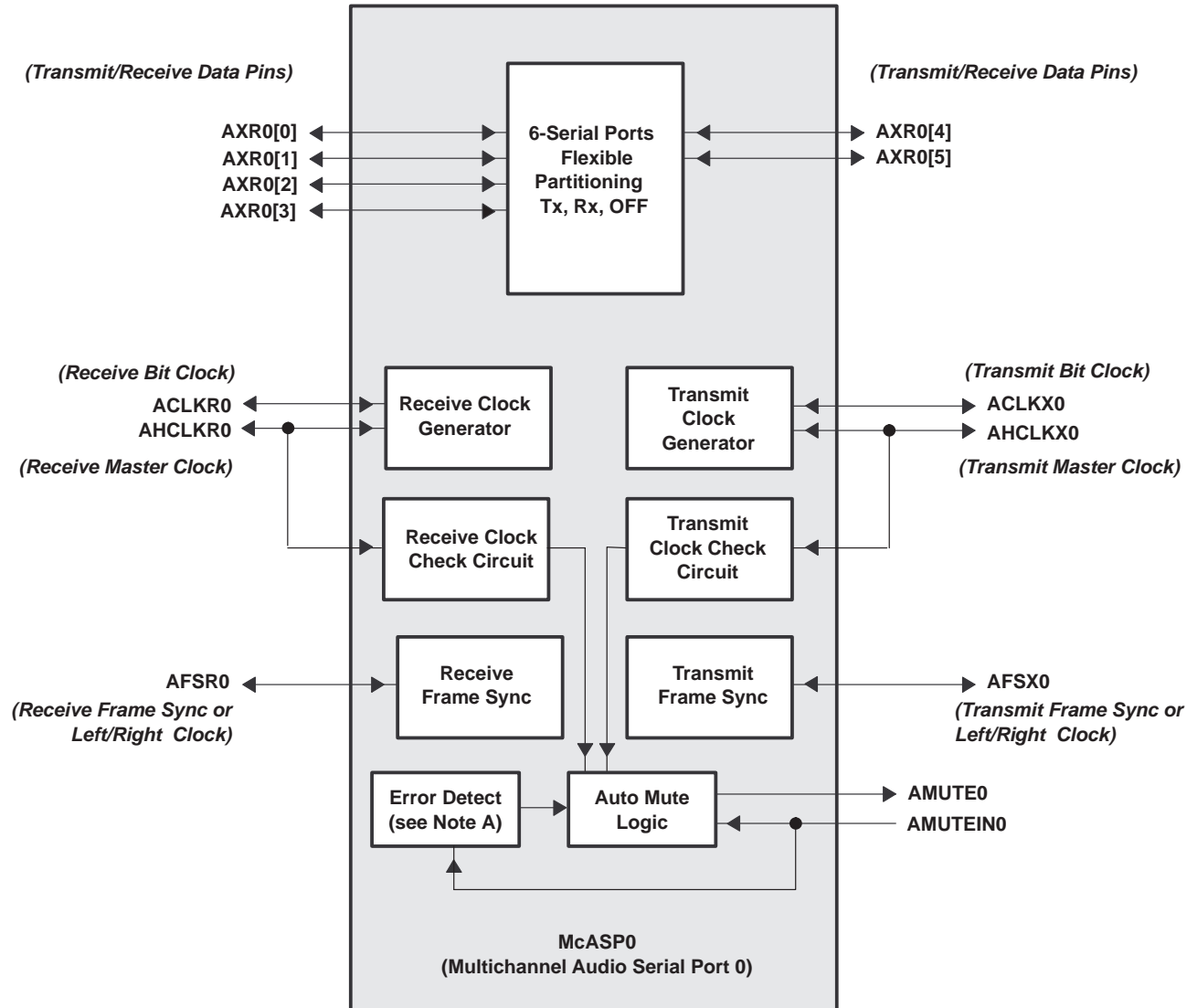
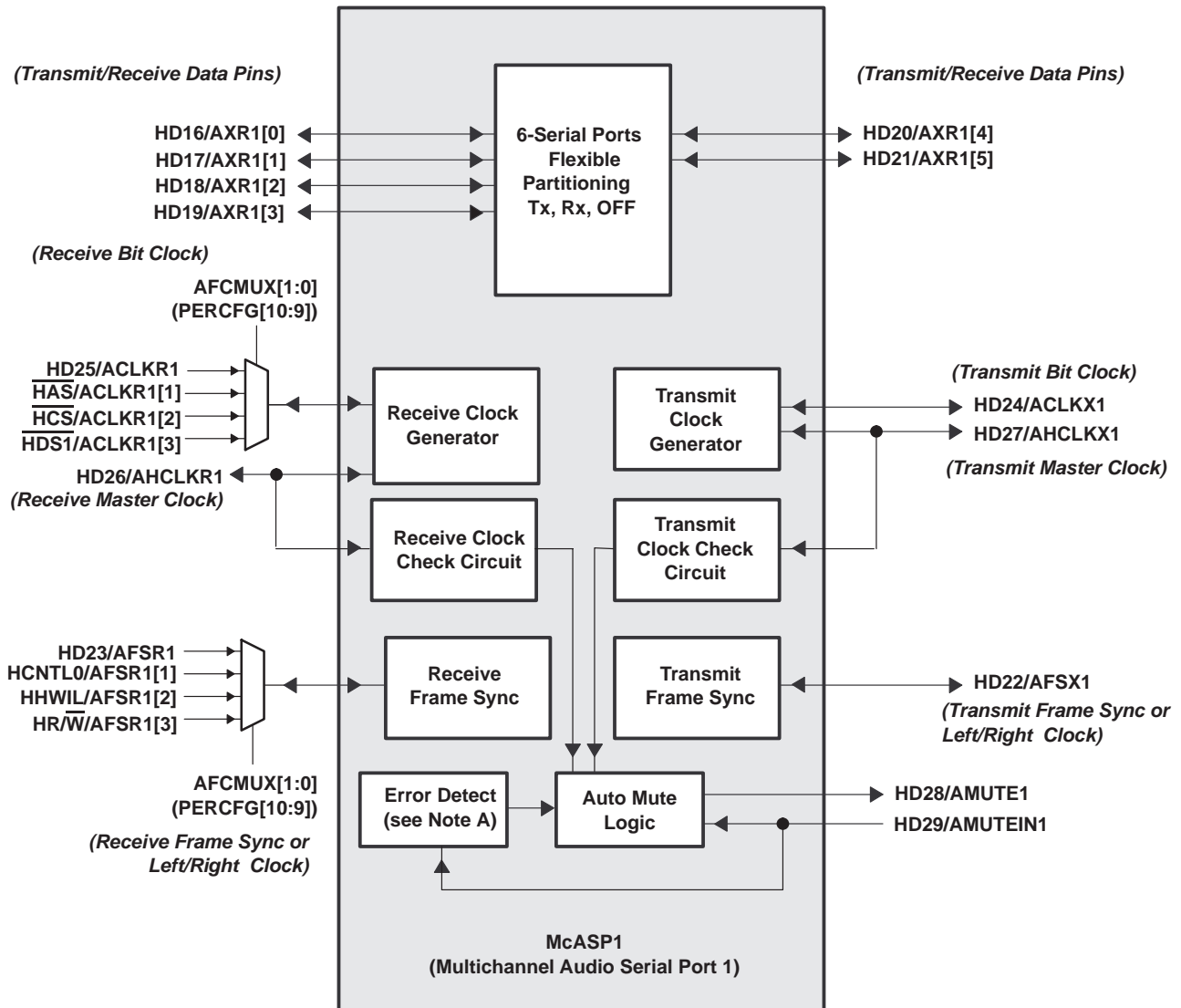

Figure 2–6. Peripheral Signals (Continued)



- NOTES: A. The McASPs' Error Detect function detects underruns, overruns, early/late frame syncs, DMA errors, and external mute input.
 B. Bolded and italicized text within parentheses denotes the function of the pins in an audio system.

Figure 2–6. Peripheral Signals (Continued)



NOTES: A. The McASPs' Error Detect function detects underruns, overruns, early/late frame syncs, DMA errors, and external mute input.
 B. Bolded and italicized text within parentheses denotes the function of the pins in an audio system.

Figure 2–6. Peripheral Signals (Continued)

3 Device Configurations

On the C6418 device, bootmode and certain device configurations/peripheral selections are determined at device reset, while other device configurations/peripheral selections are software-configurable via the peripheral configurations register (PERCFG) [address location 0x01B3F000] after device reset.

3.1 Device Configuration at Device Reset

Table 3–1 describes the C6418 device configuration pins. The logic level of the AEA[22:19], TOUT1/LENDIAN, TOUT0/HPI_EN, and HD5 pins is latched at reset to determine the device configuration. The logic level on the device configuration pins can be set by using external pullup/pulldown resistors or by using some control device (e.g., FPGA/CPLD) to intelligently drive these pins. When using a control device, care should be taken to ensure there is no contention on the lines when the device is out of reset. The CLKINSEL and OSC_DIS configuration pins should remain driven to the correct levels during device operation and must only be changed when $\overline{\text{RESET}}$ is low. The device configuration pins are sampled during reset and are driven after the reset is removed. At this time, the control device should ensure it has stopped driving the device configuration pins of the DSP to again avoid contention.

Note: If a configuration pin must be routed out from the device, the internal pullup/pulldown (IPU/IPD) resistor should not be relied upon. TI recommends the use of an external pullup/pulldown resistor.

Table 3–1. C6418 Device Configuration Pins (TOUT1/LENDIAN, AEA[22:19], TOUT0/HPI_EN, HD5, CLKINSEL, and OSC_DIS)

| CONFIGURATION PIN | NO. | IPD/IPU† | FUNCTIONAL DESCRIPTION |
|----------------------|------------|----------|---|
| TOUT1/LENDIAN | AA1 | IPU | Device Endian mode (LEND) 0 – System operates in Big Endian mode 1 – System operates in Little Endian mode (default) |
| AEA[22:21] | [M21, N21] | IPD | Bootmode [1:0] 00 – No boot (default mode) 01 – HPI boot (based on <u>HPI_EN</u> pin) 10 – Reserved 11 – EMIFA 8-bit ROM boot |
| AEA[20:19] | [P22, N22] | IPD | EMIFA input clock select Clock mode select for EMIFA (AECLKIN_SEL[1:0]) 00 – AECLKIN (default mode) 01 – CPU/4 Clock Rate 10 – CPU/6 Clock Rate 11 – Reserved |
| TOUT0/ <u>HPI_EN</u> | AA2 | IPD | HPI, McASP1, GP0[15:8] select Selects whether the HPI peripheral or McASP1 peripheral, and GP0[15:8] pins are functionally enabled 0 – HPI is enabled and the McASP1 peripheral and GP0 [15:8] pins are disabled (default mode); [HPI32, if HD5 = 1; HPI16 if HD5 = 0] 1 – HPI I is disabled and the McASP1 peripheral and GP0 [15:8] pins are enabled For more detail on the peripherals (McASP1 and GP0[15:8] pins) muxed with HPI, see the Table 3–2. |
| HD5 | Y13 | IPU | HPI peripheral bus width (HPI_WIDTH) select 0 – HPI operates as an HPI16. (HPI bus is 16 bits wide. HD[15:0] pins are used for HPI and the remaining HD[31:16] muxed pins function as McASP1 peripheral pins or are reserved pins in the Hi-Z state.) 1 – HPI operates as an HPI32. (HPI bus is 32 bits wide. All HD[31:0] pins are used for host-port operations.) For more detail on the peripherals (McASP1 and GP0[15:8] pins) muxed with HPI, see the Table 3–2. |
| CLKINSEL | A11 | IPU | PLL input clock source select Selects whether the PLL input clock is CLKIN [pin high] or directly from the crystal oscillator (OSCIN and OSCOUT) [pin low]. For proper device operation, this pin must be used in conjunction with the OSC_DIS pin. 0 – Oscillator pads (OSCIN, OSCOUT directly from the crystal oscillator) For proper device operation, OSC_DIS must be 0 1 – CLKIN square wave (default) For proper device operation, OSC_DIS must be 1 This pin must be pulled to the correct level even after reset. |
| OSC_DIS | B7 | IPU | Oscillator disable Selects whether the Oscillator is enabled or disabled. For proper device operation, this pin must follow the CLKINSEL pin operation. 0 – OSC enabled 1 – OSC disabled (default) This pin must be pulled to the correct level even after reset. |

† IPD = Internal pulldown, IPU = Internal pullup. (These IPD/IPU signal pins feature a 30-k Ω IPD or IPU resistor. To pull up a signal to the opposite supply rail, a 1-k Ω resistor should be used.)

3.2 Peripheral Configuration at Device Reset

Some C6418 peripherals share the same pins (internally muxed) and are mutually exclusive (i.e., HPI, general-purpose input/output 0 pins GP0[15:8], and McASP1).

- HPI, McASP1, and GP0 peripherals

The TOUT0/ $\overline{\text{HPI_EN}}$ (AA2 pin) is latched at reset. This pin selects whether the HPI peripheral or McASP1 peripheral, and GP0[15:8] pins are functionally enabled (see Table 3–2).

Table 3–2. TOUT0/ $\overline{\text{HPI_EN}}$ and HD5 Peripheral Selection (HPI or McASP1 and Select GP0 Pins)†

| PERIPHERAL SELECTION | | PERIPHERALS SELECTED | | | DESCRIPTION |
|--------------------------------------|-----------------------------|----------------------|-----------|------------|---|
| $\overline{\text{HPI_EN}}$ (AA2) | HD5 [HPI_WIDTH] (Y13) | HPI | McASP1 | GP0 [15:8] | |
| 0 | 0 | 16-bit HPI | Available | N/A‡ | $\overline{\text{HPI_EN}} = 0$, HD5 = 0 HPI16 is enabled and McASP1 peripheral is enabled and GP0 [15:8] pins are disabled. All multiplexed HPI/McASP1 pins function as McASP1 pins. All multiplexed HPI/GP0 are reserved pins in the Hi-Z state. |
| 0 | 1 | 32-bit HPI | N/A‡ | N/A‡ | $\overline{\text{HPI_EN}} = 0$, HD5 = 1 HPI32 is enabled and McASP1 peripheral and GP0 [15:8] pins are disabled. All multiplexed HPI/McASP1 and HPI/GP0 pins function as HPI pins. |
| 1 | x | N/A‡ | Available | Available | $\overline{\text{HPI_EN}} = 1$, HD5 = x (don't care) HPI is disabled and the McASP1 peripheral and GP0 [15:8] pins are enabled. All multiplexed HPI/McASP1 and HPI/GP0 pins function as McASP1 and GP0 pins, respectively. To use the GP0 pins, the appropriate bits in the GP0EN and GP0DIR registers need to be set. All standalone HPI pins are reserved pins in the Hi-Z state |

† The TOUT0/ $\overline{\text{HPI_EN}}$ pin has an internal pulldown that enables the HPI by default. The TOUT0/ $\overline{\text{HPI_EN}}$ pin **can** disable the HPI via an external pullup resistor or be driven high during reset. The TOUT0/ $\overline{\text{HPI_EN}}$ pin is **not** software-controllable.

‡ N/A = Not available

3.3 Peripheral Selection After Device Reset

HPI, McBSP1, McBSP0, McASP1, McASP0, I2C1, and I2C0

The C6418 device has designated registers for peripheral configuration (PERCFG), device status (DEVSTAT), and JTAG identification (JTAGID). These registers are part of the Device Configuration module and are mapped to a 4K block memory starting at 0x01B3F000. The CPU accesses these registers via the CFGBUS.

The peripheral configuration register (PERCFG), allows the user to control the peripheral selection of the McASP1, McASP0, I2C1, and I2C0 peripherals. For more detailed information on the PERCFG register control bits, see Figure 3–1 and Table 3–3.

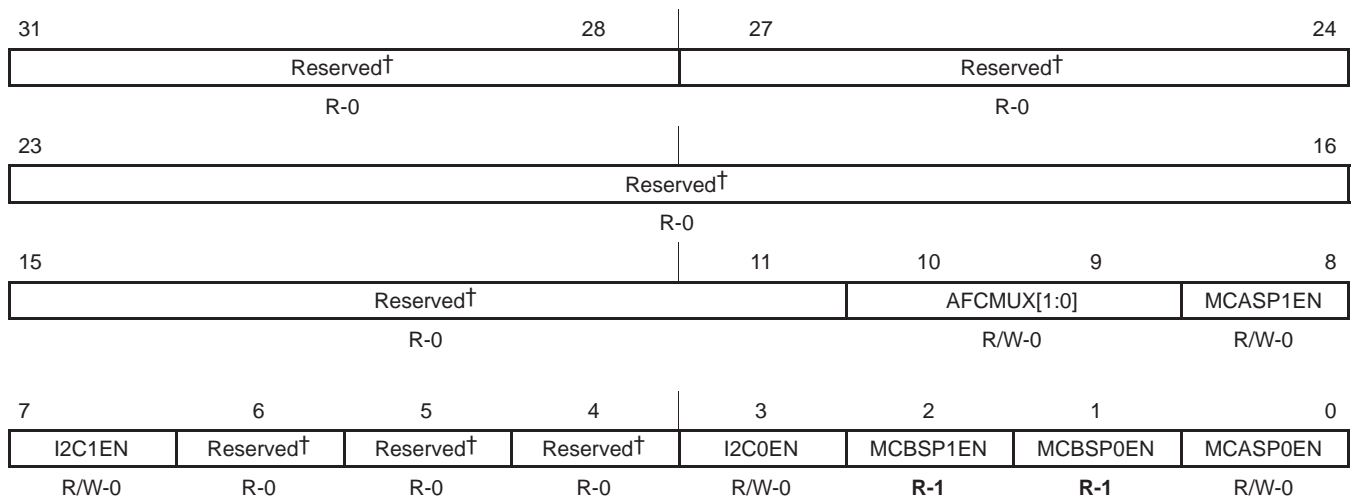

Legend: R = Read only; R/W = Read/Write; -n = value after reset

† For proper device operation, all reserved bits have to be written with "0".

Figure 3–1. Peripheral Configuration Register (PERCFG) [Address Location: 0x01B3F000]

Table 3–3. Peripheral Configuration (PERCFG) Register Selection Bit Descriptions

| BIT | NAME | DESCRIPTION |
|-------|-------------|--|
| 31:11 | Reserved | Reserved. Read-only, for proper device operation, all reserved bits have to be written with "0". |
| 10:9 | AFCMUX[1:0] | Clocks and frame syncs select bits. Determines which of the clock and frame sync pairs are input to McASP1. 00 = ACLKR1, AFSR1 pins (default). 01 = ACLKR1[1], AFSR1[1] pins 10 = ACLKR1[2], AFSR1[2] pins 11 = ACLKR1[3], AFSR1[3] pins [designed for multiple non-simultaneous I2S sources with different clock sources]. Note: The AFCMUX bits can <i>only</i> be changed when the McASP receiver is in reset. |
| 8 | MCASP1EN | McASP1 select bit. Selects whether the McASP1 peripheral is enabled or disabled (default). (This feature allows power savings by disabling the peripheral when not in use.) 0 = McASP1 is disabled and the module is powered down [default]. 1 = McASP1 is enabled. |
| 7 | I2C1EN | Inter-integrated circuit 1 (I2C1) enable bit. Selects whether I2C1 peripheral is enabled or disabled (default). (This feature allows power savings by disabling the peripheral when not in use.) 0 = I2C1 is disabled, and the module is powered down (default). 1 = I2C1 is enabled. |
| 6:4 | Reserved | Reserved. Read-only, for proper device operation, all reserved bits have to be written with "0". |
| 3 | I2C0EN | Inter-integrated circuit 0 (I2C0) enable bit. Selects whether I2C0 peripheral is enabled or disabled (default). (This feature allows power savings by disabling the peripheral when not in use.) 0 = I2C0 is disabled, and the module is powered down (default). 1 = I2C0 is enabled. |
| 2 | MCBSP1EN | McBSP1 enable bit. This bit is read-only as a "1" (McBSP1 always enabled). |
| 1 | MCBSP0EN | McBSP0 enable bit . This bit is read-only as a "1" (McBSP0 always enabled). |
| 0 | MCASP0EN | McASP0 select bit. Selects whether the McASP0 peripheral is enabled or disabled. (This feature allows power savings by disabling the peripheral when not in use.) 0 = McASP0 is disabled. 1 = McASP0 is enabled. |

3.4 Peripheral Configuration Lock

By default, the McASP1, McASP0, I2C1, and I2C0 peripherals are disabled on power up. In order to use these peripherals on the C6418 device, the peripheral must first be enabled in the Peripheral Configuration register (PERCFG). **Software muxed pins should not be programmed to switch functionalities during run-time. Care should also be taken to ensure that no accesses are being performed before disabling the peripherals.** To help minimize power consumption in the C6418 device, unused peripherals may be disabled.

Figure 3–2 shows the flow needed to enable (or disable) a given peripheral on the C6418 device.

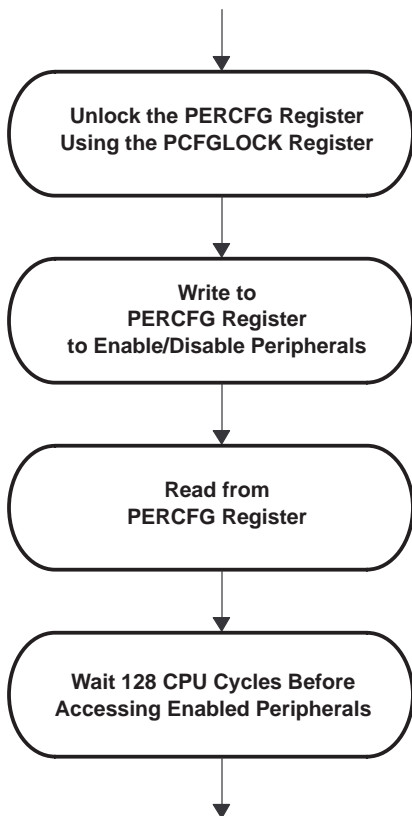

Figure 3–2. Peripheral Enable/Disable Flow Diagram

A 32-bit key (value = 0x10C0010C) must be written to the Peripheral Configuration Lock register (PCFGLOCK) in order to unlock access to the PERCFG register. Reading the PCFGLOCK register determines whether the PERCFG register is currently locked (LOCKSTAT bit = 1) or unlocked (LOCKSTAT bit = 0), see Figure 3–3. A peripheral can only be enabled when the PERCFG register is “unlocked” (LOCKSTAT bit = 0).

Read Accesses

| | | | |
|----|----------|------------|----------|
| 31 | Reserved | 1 | 0 |
| | | PWRSAVSTAT | LOCKSTAT |
| | R-0 | R-0 | R-1 |

Write Accesses

| | | |
|----|------|---|
| 31 | LOCK | 0 |
| | W-0 | |

Legend: R = Read only; R/W = Read/Write; -n = value after reset

Figure 3–3. PCFGLOCK Register Diagram [Address Location: 0x01B3 F018] – Read/Write Accesses

Table 3–4. PCFGLOCK Register Selection Bit Descriptions – Read Accesses

| BIT | NAME | DESCRIPTION |
|------|------------|--|
| 31:2 | Reserved | Reserved. Read-only, writes have no effect. |
| 1 | PWRSAVSTAT | Power-saver status bit. Determines whether the power saver function is enabled or disabled. 0 = Power-saver is enabled [default]. 1 = Power-saver is disabled |
| 0 | LOCKSTAT | Lock status bit. Determines whether the PERCFG register is locked or unlocked. 0 = Unlocked, read accesses to the PERCFG register allowed. 1 = Locked, write accesses to the PERCFG register do not modify the register state [default]. Reads are unaffected by Lock Status. |

Table 3–5. PCFGLOCK Register Selection Bit Descriptions – Write Accesses

| BIT | NAME | DESCRIPTION |
|------|------|--|
| 31:0 | LOCK | Lock bits. 0x10C0010C = Unlocks PERCFG register accesses. |

Any write to the PERCFG register will automatically relock the register. In order to avoid the unnecessary overhead of multiple unlock/enable sequences, all peripherals should be enabled with a single write to the PERCFG register with the necessary enable bits set.

Prior to waiting 128 CPU cycles, the PERCFG register should be read. There is no direct correlation between the CPU issuing a write to the PERCFG register and the write actually occurring. Reading the PERCFG register after the write is issued forces the CPU to wait for the write to the PERCFG register to occur.

Once a peripheral is enabled, the DSP (or other peripherals such as the HPI) must wait a minimum of 128 CPU cycles before accessing the enabled peripheral. The user *must* ensure that no accesses are performed to a peripheral while it is disabled.

In addition to the normal usage, the PCFGLOCK register can be used to override the power saver settings specified in the PERCFG register. When the power saver feature is disabled (PCFGLOCK written with 0xC0100C01), all peripherals controlled by PERCFG are enabled. If the power saver is returned to normal operation (PCFGLOCK written with 0x0C01C010), then the peripherals return to the operating condition specified by PERCFG. Turning off the power saver settings will add a worst-case 50 mW of power to the overall DSP power consumption.

Note: overriding the settings of the PERCFG register will not cause a conflict on the multiplexed pins. For example, with the HPI and McASP1 peripherals, the HPI will still have control over the multiplexed pins provided the TOUT0/HPI_EN pin was “0” at reset.

3.5 Device Status Register Description

The device status register depicts the status of the device peripheral selection. Once set, these bits will remain set until a device reset; therefore, these bits should be masked when reading the DEVSTAT register since their values can change. For the actual register bit names and their associated bit field descriptions, see Figure 3–4 and Table 3–6.

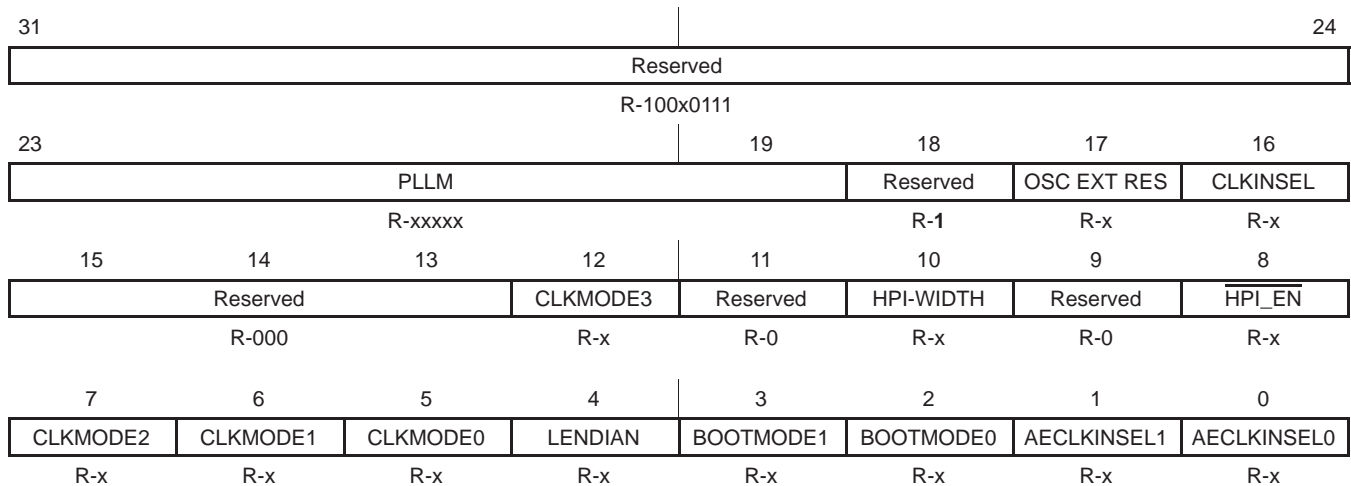

Legend: R = Read only; R/W = Read/Write; -n = value after reset

Figure 3–4. Device Status Register (DEVSTAT) Description – 0x01B3 F004

Table 3–6. Device Status (DEVSTAT) Register Selection Bit Descriptions

| BIT | NAME | DESCRIPTION |
|-------|-------------|---|
| 31:24 | Reserved | Reserved. Read-only, writes have no effect. |
| 23:19 | PLLM | PLL multiply factor status bits. Shows the status of the PLL multiply mode selected; whether the CPU clock frequency equals the input clock frequency x1 (Bypass), x5, x6, x7, x8, x9, x10, x11, x12, x16, x18, x19, x20, x21, x22, or x24. For more detailed information on the PLL multiply factors, see the <i>Clock PLL</i> section of this data sheet. |
| 18 | Reserved | Reserved. Read-only, writes have no effect. |
| 17 | OSC EXT RES | Oscillator external resistor status bit. Shows the status internal or external of the OSC bias resistor. 0 = Normal functional mode with internal bias resistor. 1 = Normal functional mode with external bias resistor [default; internally tied high]. |
| 16 | CLKINSEL | PLL input clock select status bit. Shows the status of whether the PLL input clock is CLKIN [pin high] or directly from the crystal oscillator (OSCIN and OSCOUT) [pin low] 0 = Crystal oscillator (OSCIN and OSCOUT). 1 = CLKIN (default). |
| 15:13 | Reserved | Reserved. Read-only, writes have no effect. |
| 11 | Reserved | Reserved. Read-only, writes have no effect. |
| 10 | HPI_WIDTH | HPI bus width control bit. Shows the status of whether the HPI bus operates in 32-bit mode or in 16-bit mode (default). 0 = HPI operates in 16-bit mode. (default). 1 = HPI operates in 32-bit mode. |
| 9 | Reserved | Reserved. Read-only, writes have no effect. |
| 8 | HPI_EN | HPI_EN pin status bit. Shows the status at device reset of the HPI_EN pin, which controls the HPI peripheral as enabled [default] or disabled. 0 = HPI_EN pin is low, meaning the HPI peripheral is enabled. (default). 1 = HPI_EN pin is high, meaning the HPI peripheral is disabled. |

Table 3–6. Device Status (DEVSTAT) Register Selection Bit Descriptions (Continued)

| BIT | NAME | DESCRIPTION |
|-----|-------------|---|
| 12 | CLKMODE3 | Clock mode select status bits Shows the status ("1" or "0") of the CLKMODE[3:0] select bits: Clock mode select for CPU clock frequency (CLKMODE[3:0]), for example: 0000– Bypass (x1) (default mode) For more details on the CLKMODE pins and the PLL multiply factors, see the <i>Clock PLL and Oscillator</i> section of this data sheet. |
| 7 | CLKMODE2 | |
| 6 | CLKMODE1 | |
| 5 | CLKMODE0 | |
| 4 | LENDIAN | Device Endian mode (LENDIAN) Shows the status of whether the system is operating in Big Endian mode or Little Endian mode (default). 0 – System is operating in Big Endian mode 1 – System is operating in Little Endian mode (default) |
| 3 | BOOTMODE1 | Bootmode configuration bits (AEA[22:21] pins) Shows the status of what device bootmode configuration is operational. Bootmode [1:0] 00 – No boot (default mode) 01 – HPI boot (based on HPI_EN pin) 10 – Reserved 11 – EMIFA 8-bit ROM boot |
| 2 | BOOTMODE0 | |
| 1 | AECLKINSEL1 | EMIFA input clock select (AEA[20:19] pins) Shows the status of what clock mode is enabled or disabled for the EMIF. Clock mode select for EMIFA (AECLKIN_SEL[1:0]) 00 – AECLKIN (default mode) 01 – CPU/4 Clock Rate 10 – CPU/6 Clock Rate 11 – Reserved |
| 0 | AECLKINSEL0 | |

3.6 JTAG ID Register Description

The JTAG ID register is a read-only register that identifies to the customer the JTAG/Device ID. For the C6418 device, the JTAG ID register resides at address location 0x01B3 F008. The register hex value for the C6418 device is: 0x0007 902F. For the actual register bit names and their associated bit field descriptions, see Figure 3–5 and Table 3–7.

| 31–28 | 27–12 | 11–1 | 0 |
|-----------------|-----------------------|-----------------------|-----|
| VARIANT (4-Bit) | PART NUMBER (16-Bit) | MANUFACTURER (11-Bit) | LSB |
| R-0000 | R-0000 0000 1000 0100 | R-0000 0010 111 | R-1 |

Legend: R = Read only; -n = value after reset

Figure 3–5. JTAG ID Register Description – TMS320C6418 Register Value – 0x0007 902F**Table 3–7. JTAG ID Register Selection Bit Descriptions**

| BIT | NAME | DESCRIPTION |
|-------|--------------|---|
| 31:28 | VARIANT | Variant (4-Bit) value. C6418 value: 0000. |
| 27:12 | PART NUMBER | Part Number (16-Bit) value. C6418 value: 0000 0000 1000 0100. |
| 11–1 | MANUFACTURER | Manufacturer (11-Bit) value. C6418 value: 0000 0010 111. |
| 0 | LSB | LSB. This bit is read as a "1" for C6418. |

3.7 Multiplexed Pins

Multiplexed pins are pins that are shared by more than one peripheral and are internally multiplexed. Some of these pins are configured by software, and the others are configured by external pullup/pulldown resistors only at reset. Those muxed pins that are configured by software should **not** be programmed to switch functionalities during run-time. Those muxed pins that are configured by external pullup/pulldown resistors are mutually exclusive; only one peripheral has primary control of the function of these pins after reset. Table 3–8 identifies the multiplexed pins on the C6418 device; shows the default (primary) function and the default settings after reset; and describes the pins, registers, etc. necessary to configure specific multiplexed functions.

Table 3–8. C6418 Device Multiplexed Pins

| MULTIPLEXED PINS | | IPD/IPU† | DEFAULT FUNCTION | DEFAULT SETTING | DESCRIPTION |
|-----------------------------|------|----------|--|---|---|
| NAME | NO. | | | | |
| CLKOUT4/GP0[1] | A2 | IPU | CLKOUT4 | GP1EN = 0 (disabled) | These pins are software-configurable. To use these pins as GPIO pins, the GPxEN bits in the GPIO Enable Register and the GPxDIR bits in the GPIO Direction Register must be properly configured. GPxEN = 1: GPx pin enabled GPxDIR = 0: GPx pin is an input GPxDIR = 1: GPx pin is an output |
| CLKOUT6/GP0[2] | B3 | IPU | CLKOUT6 | GP2EN = 0 (disabled) | |
| HCNTL0/AFSR1[1] | Y6 | IPU | HPI pin function HHWIL pin (HPI16 only) | TOUT0/ <u>HPI_EN</u> = 0, HD5 = 1 (32-Bit HPI enabled) McASP1 pins disabled. | By default, HPI32 is enabled upon reset (McASP1 is disabled). To enable the McASP1 peripheral, the TOUT0/ <u>HPI_EN</u> pin must be high at reset either via an external pullup (PU) resistor (1 kΩ) or driven by a control device (disabling the HPI). or the McASP1 peripheral pins can be used if the HPI is used as a 16-bit width [<u>HPI_EN</u> = 0, HD5 = 0]. The clocks and frame syncs select bits (AFCMUX[1:0]) located in the PERCFG register determine which of the clock and frame sync pairs are input to McASP1. For more detailed information, see the Device Configuration section of this data sheet. |
| HHWIL/AFSR1[2] | Y7 | | | | |
| HR \overline{W} /AFSR1[3] | AA5 | | | | |
| <u>HAS</u> /ACLKR1[1] | Y5 | | | | |
| <u>HCS</u> /ACLKR1[2] | AA11 | | | | |
| <u>HDS1</u> /ACLKR1[3] | AB11 | | | | |
| HD29/AMUTEIN1 | W11 | | | | |
| HD28/AMUTE1 | W10 | | | | |
| HD27/AHCLKX1 | Y4 | | | | |
| HD26/AHCLKR1 | AB4 | | | | |
| HD25/ACLKR1 | AA9 | | | | |
| HD24/ACLKX1 | AA4 | | | | |
| HD23/AFSR1 | AB9 | | | | |
| HD22/AFSX1 | AB5 | | | | |
| HD21/AXR1[5] | Y9 | IPU | HPI pin function | TOUT0/ <u>HPI_EN</u> = 0, HD5 = 1 (32-Bit HPI enabled) McASP1 pins disabled. | By default, HPI32 is enabled upon reset (McASP1 is disabled). To enable the McASP1 peripheral, the TOUT0/ <u>HPI_EN</u> pin must be high at reset either via an external pullup (PU) resistor (1 kΩ) or driven by a control device (disabling the HPI). or the McASP1 peripheral pins can be used if the HPI is used as a 16-bit width [<u>HPI_EN</u> = 0, HD5 = 0]. McASP1 pin direction is controlled by the PDIR[x] bits in the McASP1PDIR register. McASP1PDIR = 0 input, = 1 output |
| HD20/AXR1[4] | AB8 | | | | |
| HD19/AXR1[3] | AA6 | | | | |
| HD18/AXR1[2] | AB7 | | | | |
| HD17/AXR1[1] | AA7 | | | | |
| HD16/AXR1[0] | AB6 | | | | |

Table 3–8. C6418 Device Multiplexed Pins (Continued)

| MULTIPLEXED PINS | | IPD/IPU† | DEFAULT FUNCTION | DEFAULT SETTING | DESCRIPTION |
|------------------|------|----------|------------------|--|--|
| NAME | NO. | | | | |
| HD15/GP0[15] | Y12 | IPU | HPI pin function | $\overline{\text{HPI_EN}} = 0, \text{HD5} = 1$ (32-Bit HPI enabled) GPIO pins disabled. | By default, HPI is enabled upon reset (GP0[15:9] pins are disabled). To use GP0[15:9] as GPIO pins, the HPI needs to be disabled ($\overline{\text{HPI_EN}} = 1, \text{HD5} = x$ (don't care)), the GPxEN bits in the GPIO Enable Register and the GPxDIR bits in the GPIO Direction Register must be properly configured. GPxEN = 1: GPx pin enabled GPxDIR = 0: GPx pin is an input GPxDIR = 1: GPx pin is an output |
| HD14/GP0[14] | AA12 | | | | |
| HD13/GP0[13] | AB13 | | | | |
| HD12/GP0[12] | Y14 | | | | |
| HD11/GP0[11] | AB14 | | | | |
| HD10/GP0[10] | AA15 | | | | |
| HD9/GP0[9] | Y16 | | | | |
| HD8/GP0[8] | AB16 | | | | |

† IPD = Internal pulldown, IPU = Internal pullup. (These IPD/IPU signal pins feature a 30-k Ω IPD or IPU resistor. To pull up a signal to the opposite supply rail, a 1-k Ω resistor should be used.)

3.8 Debugging Considerations

It is recommended that external connections be provided to device configuration pins, including TOUT1/LENDIAN, AEA[22:19], TOUT0/ $\overline{\text{HPI_EN}}$, CLKINSEL, and OSC_DIS. Although internal pullup/pulldown resistors exist on these pins, providing external connectivity adds convenience to the user in debugging and flexibility in switching operating modes.

Note: If a configuration pin must be routed out from the device, the internal pullup/pulldown (IPU/IPD) resistor should not be relied upon. TI recommends the use of an external pullup/pulldown resistor.

3.9 Configuration Examples

Figure 3–6 illustrates an example of peripheral selections/options that are configurable on the C6418 device.

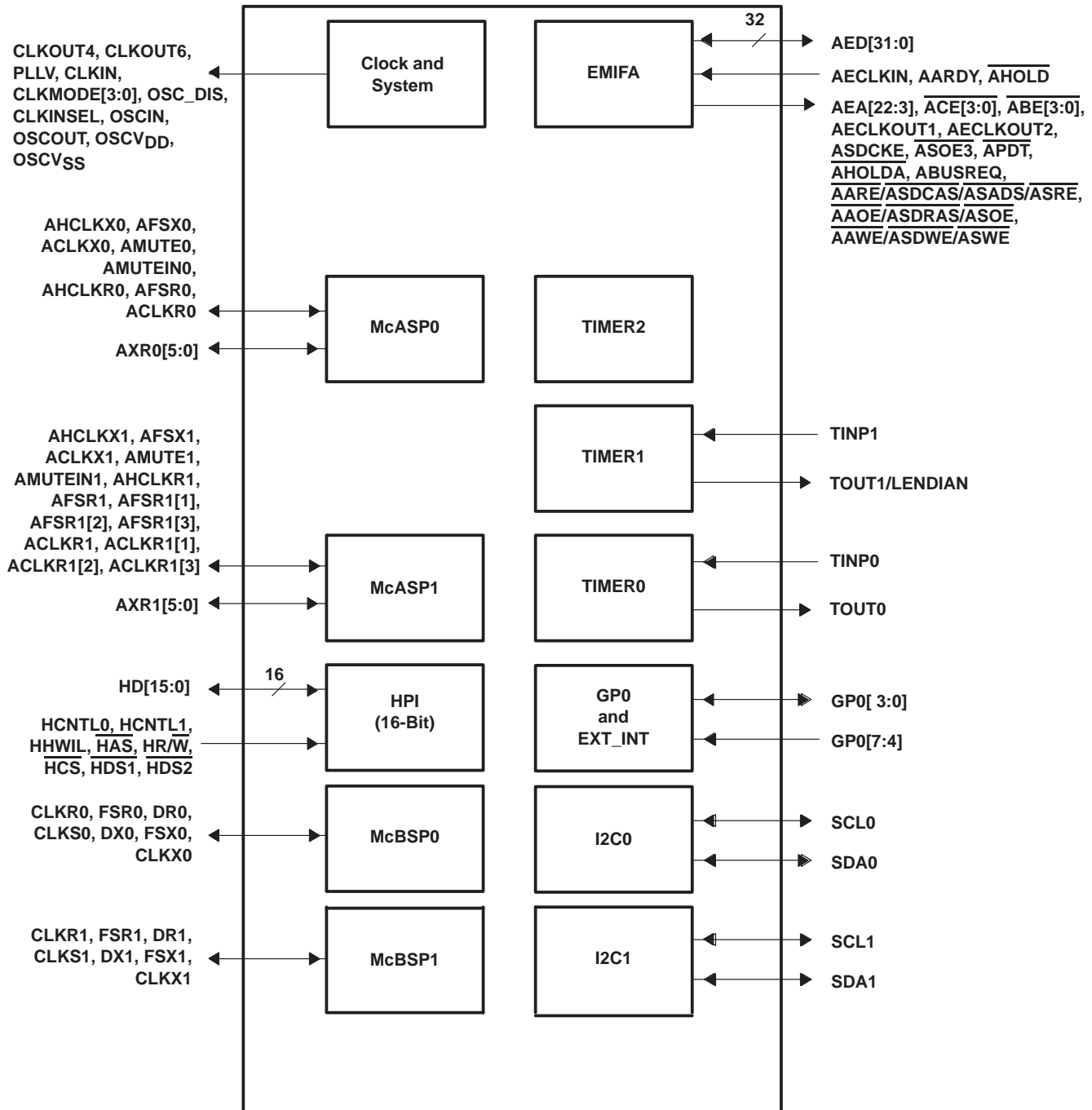

PERCFG Register Value: 0x0000_018F [CPU/4 option [default] and AFSR1, ACLKR1 pins selected]
 External Pins: TOUT0/HPI_EN = 0; HD5 = 0 (IPU)

**Figure 3–6. Configuration Example A
 (HPI16 + 2 McASPs + 2 McBSPs + 2 I2Cs + EMIF + 3 Timers + GPIO)**

3.10 Terminal Functions

The terminal functions table (Table 3–9) identifies the external signal names, the associated pin (ball) numbers along with the mechanical package designator, the pin type (I, O/Z, or I/O/Z), whether the pin has any internal pullup/pulldown resistors and a functional pin description. For more detailed information on device configuration, peripheral selection, multiplexed/shared pins, and debugging considerations, see the Device Configurations section of this data sheet.

Table 3–9. Terminal Functions

| SIGNAL NAME | NO. | TYPE† | IPD/ IPU‡ | DESCRIPTION |
|--------------------------------|-----|-------|--------------|---|
| CLOCK/PLL CONFIGURATION | | | | |
| CLKIN | A12 | I | IPD | Clock Input. This clock is the input to the on-chip PLL. |
| CLKOUT4/GP0[1]§ | A2 | I/O/Z | IPU | Clock output at 1/4 of the device speed (O/Z) [default] or this pin can be programmed as a GP0 1 pin (I/O/Z). |
| CLKOUT6/GP0[2]§ | B3 | I/O/Z | IPU | Clock output at 1/6 of the device speed (O/Z) [default] or this pin can be programmed as a GP0 2 pin (I/O/Z). |
| CLKINSEL | A11 | I | IPU | CLKIN select. Selects whether the PLL input clock is CLKIN [pin high] or directly from the crystal oscillator (OSCIN and OSCOUT) [pin low]. For proper device operation, this pin must be used in conjunction with the OSC_DIS pin. |
| CLKMODE3 | C11 | I | IPD | Clock mode selects • Selects whether the CPU clock frequency = input clock frequency x1 (Bypass), x5, x6, x7, x8, x9, x10, x11, x12, x16, x18, x19, x20, x21, x22, or x24. For more details on the CLKMODE pins and the PLL multiply factors, see the Clock PLL section of this data sheet. |
| CLKMODE2 | B10 | I | IPD | |
| CLKMODE1 | A13 | I | IPD | |
| CLKMODE0 | C13 | I | IPD | |
| PLLV¶ | C12 | A | | PLL voltage supply |
| OSCIN | A6 | I | — | Crystal oscillator Input (XI) |
| OSCOUT | A7 | O | — | Crystal oscillator output (XO) |
| OSCV _{DD} | B6 | S | — | Power for crystal oscillator (1.2 V), Do not connect to board power CV _{DD} ; for optimum performance, connected internally. If CLKIN is used instead of the oscillator, then this pin can be left open or connected to CV _{DD} . |
| OSCV _{SS} | C6 | GND | — | Ground for crystal oscillator, Do not connect to board ground; for optimum performance, connected internally. If CLKIN is used instead of the oscillator, then this pin can be left open or connected to V _{SS} . |
| OSC_DIS | B7 | I | IPU | Oscillator disable select. For proper device operation, this pin must follow the CLKINSEL pin operation. 0 – OSC enabled; CLKINSEL must be 0 1 – OSC disabled (default); CLKINSEL must be 1 |
| JTAG EMULATION | | | | |
| TMS | U3 | I | IPU | JTAG test-port mode select |
| TDO | T4 | O/Z | IPU | JTAG test-port data out |
| TDI | T1 | I | IPU | JTAG test-port data in |
| TCK | T2 | I | IPU | JTAG test-port clock |
| $\overline{\text{TRST}}$ | U1 | I | IPD | JTAG test-port reset. For IEEE 1149.1 JTAG compatibility, see the IEEE 1149.1 JTAG compatibility statement portion of this data sheet. |
| EMU0 | R1 | I/O/Z | IPU | Emulation pin 0# |
| EMU1 | T3 | I/O/Z | IPU | Emulation pin 1# |

† I = Input, O = Output, Z = High impedance, S = Supply voltage, GND = Ground, A = Analog Signal

‡ IPD = Internal pulldown, IPU = Internal pullup. (These IPD/IPU signal pins feature a 30-k Ω IPD or IPU resistor. To pull up a signal to the opposite supply rail, a 1-k Ω resistor should be used.)

§ These pins are multiplexed pins. For more details, see the Device Configurations section of this data sheet.

¶ PLLV is not part of external voltage supply. See the Clock PLL and Oscillator section for information on how to connect this pin.

The EMU0 and EMU1 pins are internally pulled up with 30-k Ω resistors; therefore, for emulation and normal operation, no external pullup/pulldown resistors are necessary. However, for boundary scan operation, pull down the EMU1 and EMU0 pins with a dedicated 1-k Ω resistor.

Table 3–9. Terminal Functions (Continued)

| NAME | NO. | TYPE† | IPD/ IPU‡ | DESCRIPTION |
|--|------|-------|--------------|---|
| JTAG EMULATION (CONTINUED) | | | | |
| EMU2 | R2 | I/O/Z | IPU | Emulation pin 2. Reserved for future use, leave unconnected. |
| EMU3 | U2 | I/O/Z | IPU | Emulation pin 3. Reserved for future use, leave unconnected. |
| EMU4 | R3 | I/O/Z | IPU | Emulation pin 4. Reserved for future use, leave unconnected. |
| EMU5 | P2 | I/O/Z | IPU | Emulation pin 5. Reserved for future use, leave unconnected. |
| EMU6 | R4 | I/O/Z | IPU | Emulation pin 6. Reserved for future use, leave unconnected. |
| EMU7 | V2 | I/O/Z | IPU | Emulation pin 7. Reserved for future use, leave unconnected. |
| EMU8 | V1 | I/O/Z | IPU | Emulation pin 8. Reserved for future use, leave unconnected. |
| EMU9 | V3 | I/O/Z | IPU | Emulation pin 9. Reserved for future use, leave unconnected. |
| EMU10 | W3 | I/O/Z | IPU | Emulation pin 10. Reserved for future use, leave unconnected. |
| EMU11 | W2 | I/O/Z | IPU | Emulation pin 11. Reserved for future use, leave unconnected. |
| RESETS, INTERRUPTS, AND GENERAL-PURPOSE INPUT/OUTPUTS | | | | |
| RESET | C9 | I | | Device reset |
| NMI | B9 | I | IPD | Nonmaskable interrupt, edge-driven (rising edge). Any noise on the NMI pin may trigger an NMI interrupt; therefore, if the NMI pin is not used, it is recommended that the NMI pin be grounded versus relying on the IPD. |
| GP0[7]/EXT_INT7 | Y1 | I/O/Z | IPU | General-purpose input/output (GPIO) pins (I/O/Z) or external interrupts (input only). The default after reset setting is GPIO enabled as input-only. <ul style="list-style-type: none"> When these pins function as External Interrupts [by selecting the corresponding interrupt enable register bit (IER.[7:4])], they are edge-driven and the polarity can be independently selected via the External Interrupt Polarity Register bits (EXTPOL.[3:0]). |
| GP0[6]/EXT_INT6 | C4 | I/O/Z | IPU | |
| GP0[5]/EXT_INT5 | B4 | I/O/Z | IPU | |
| GP0[4]/EXT_INT4 | A4 | I/O/Z | IPU | |
| HD15/GP0[15] | Y12 | I/O/Z | IPU | Host-port data pins (I/O/Z) [default] or General-purpose input/output (GP0) [15:8] pins (I/O/Z) GP0 [3:0] pins (I/O/Z) Clock output at 1/6 of the device speed (O/Z) [default] or this pin can be programmed as a GP0 2 pin (I/O/Z). Clock output at 1/4 of the device speed (O/Z) [default] or this pin can be programmed as a GP0 1 pin (I/O/Z). |
| HD14/GP0[14] | AA12 | | | |
| HD13/GP0[13] | AB13 | | | |
| HD12/GP0[12] | Y14 | | | |
| HD11/GP0[11] | AB14 | | | |
| HD10/GP0[10] | AA15 | | | |
| HD9/GP0[9] | Y16 | | | |
| HD8/GP0[8] | AB16 | | | |
| GP0[3] | B13 | I/O/Z | IPD | |
| CLKOUT6/GP0[2]§ | B3 | I/O/Z | IPU | |
| CLKOUT4/GP0[1]§ | A2 | I/O/Z | IPU | |
| GP0[0] | D13 | I/O/Z | IPD | |

† I = Input, O = Output, Z = High impedance, S = Supply voltage, GND = Ground, A = Analog Signal

‡ IPD = Internal pulldown, IPU = Internal pullup. (These IPD/IPU signal pins feature a 30-kΩ IPD or IPU resistor. To pull up a signal to the opposite supply rail, a 1-kΩ resistor should be used.)

§ These pins are multiplexed pins. For more details, see the Device Configurations section of this data sheet.

Table 3–9. Terminal Functions (Continued)

| NAME | NO. | TYPE† | IPD/ IPU‡ | DESCRIPTION |
|--|------|-------|--------------|---|
| EMIFA (32-BIT) – CONTROL SIGNALS COMMON TO ALL TYPES OF MEMORY | | | | |
| $\overline{ACE3}$ | H19 | O/Z | IPU | EMIFA memory space enables <ul style="list-style-type: none"> Enabled by bits 28 through 31 of the word address Only one pin is asserted during any external data access |
| $\overline{ACE2}$ | N20 | O/Z | IPU | |
| $\overline{ACE1}$ | R20 | O/Z | IPU | |
| $\overline{ACE0}$ | F20 | O/Z | IPU | |
| $\overline{ABE3}$ | AB21 | O/Z | IPU | EMIFA byte-enable control <ul style="list-style-type: none"> Decoded from the low-order address bits. The number of address bits or byte enables used depends on the width of external memory. Byte-write enables for most types of memory Can be directly connected to SDRAM read and write mask signal (SDQM) |
| $\overline{ABE2}$ | P21 | O/Z | IPU | |
| $\overline{ABE1}$ | A22 | O/Z | IPU | |
| $\overline{ABE0}$ | D16 | O/Z | IPU | |
| \overline{APDT} | T19 | O/Z | IPU | EMIFA peripheral data transfer, allows direct transfer between external peripherals |
| EMIFA (32-BIT) – BUS ARBITRATION | | | | |
| \overline{AHOLDA} | J21 | O | IPU | EMIFA hold-request-acknowledge to the host |
| \overline{AHOLD} | J22 | I | IPU | EMIFA hold request from the host |
| $\overline{ABUSREQ}$ | R19 | O | IPU | EMIFA bus request output |
| EMIFA (32-BIT) – ASYNCHRONOUS/SYNCHRONOUS MEMORY CONTROL | | | | |
| $\overline{AECLKIN}$ | K22 | I | IPD | EMIFA external input clock. The EMIFA input clock ($\overline{AECLKIN}$, CPU/4 clock, or CPU/6 clock) is selected at reset via the pullup/pulldown resistors on the AEA[20:19] pins. $\overline{AECLKIN}$ is the default for the EMIFA input clock. |
| $\overline{AECLKOUT2}$ | U22 | O/Z | IPD | EMIFA output clock 2. Programmable to be EMIFA input clock ($\overline{AECLKIN}$, CPU/4 clock, or CPU/6 clock) frequency divided-by-1, -2, or -4. |
| $\overline{AECLKOUT1}$ | F22 | O/Z | IPD | EMIFA output clock 1 [at EMIFA input clock ($\overline{AECLKIN}$, CPU/4 clock, or CPU/6 clock) frequency]. |
| $\overline{AARE}/$ $\overline{ASDCAS}/$ $\overline{ASADS}/\overline{ASRE}$ | D20 | O/Z | IPU | EMIFA asynchronous memory read-enable/SDRAM column-address strobe/programmable synchronous interface-address strobe or read-enable <ul style="list-style-type: none"> For programmable synchronous interface, the RENEN field in the CE Space Secondary Control Register (CEXSEC) selects between \overline{ASADS} and \overline{ASRE}: If RENEN = 0, then the $\overline{ASADS}/\overline{ASRE}$ signal functions as the \overline{ASADS} signal. If RENEN = 1, then the $\overline{ASADS}/\overline{ASRE}$ signal functions as the \overline{ASRE} signal. |
| $\overline{AAOE}/$ $\overline{ASDRAS}/$ \overline{ASOE} | E20 | O/Z | IPU | EMIFA asynchronous memory output-enable/SDRAM row-address strobe/programmable synchronous interface output-enable |
| $\overline{AAWE}/$ $\overline{ASDWE}/$ \overline{ASWE} | C20 | O/Z | IPU | EMIFA asynchronous memory write-enable/SDRAM write-enable/programmable synchronous interface write-enable |
| \overline{ASDCKE} | K21 | O/Z | IPU | EMIFA SDRAM clock-enable (used for self-refresh mode). <ul style="list-style-type: none"> If SDRAM is not in system, \overline{ASDCKE} can be used as a general-purpose output. |
| $\overline{ASOE3}$ | P19 | O/Z | IPU | EMIFA synchronous memory output-enable for $\overline{ACE3}$ (for glueless FIFO interface) |
| \overline{AARDY} | L21 | I | IPU | Asynchronous memory ready input |

† I = Input, O = Output, Z = High impedance, S = Supply voltage, GND = Ground, A = Analog Signal

‡ IPD = Internal pulldown, IPU = Internal pullup. (These IPD/IPU signal pins feature a 30-k Ω IPD or IPU resistor. To pull up a signal to the opposite supply rail, a 1-k Ω resistor should be used.)

§ These pins are multiplexed pins. For more details, see the Device Configurations section of this data sheet.

Table 3–9. Terminal Functions (Continued)

| NAME | NO. | TYPE† | IPD/ IPU‡ | DESCRIPTION |
|---------------------------------|------|-------|--------------|---|
| EMIFA (32-BIT) – ADDRESS | | | | |
| AEA22 | M21 | I/O/Z | IPD | EMIFA external address (word address) Note: EMIF address numbering for the C6418 device starts with AEA3 to maintain signal name compatibility with other C64x™ devices (e.g., C6411, C6414, C6415, and C6416) [see the 64-bit EMIF addressing scheme in the <i>TMS320C6000 DSP External Memory Interface (EMIF) Reference Guide</i> (literature number SPRU266)]. |
| AEA21 | N21 | | | |
| AEA20 | P22 | | | |
| AEA19 | N22 | | | |
| AEA18 | H22 | O/Z | IPD | <p>Note: If a configuration pin must be routed out from the device, the internal pullup/pulldown (IPU/IPD) resistor should not be relied upon. TI recommends the use of an external pullup/pulldown resistor.</p> <ul style="list-style-type: none"> • Also controls initialization of DSP modes at reset (I) via pullup/pulldown resistors <ul style="list-style-type: none"> – Boot mode (AEA[22:21]): <ul style="list-style-type: none"> 00 – No boot (default mode) 01 – HPI boot (based on $\overline{\text{HPI_EN}}$ pin) 10 – Reserved 11 – EMIFA 8-bit ROM boot – EMIF clock select – AEA[20:19]: Clock mode select for EMIFA (AECLKIN_SEL[1:0]) <ul style="list-style-type: none"> 00 – AECLKIN (default mode) 01 – CPU/4 Clock Rate 10 – CPU/6 Clock Rate 11 – Reserved <p>For more details, see the Device Configurations section of this data sheet.</p> |
| AEA17 | H21 | | | |
| AEA16 | J20 | | | |
| AEA15 | H20 | | | |
| AEA14 | G20 | | | |
| AEA13 | K20 | | | |
| AEA12 | B21 | | | |
| AEA11 | B22 | | | |
| AEA10 | D21 | | | |
| AEA9 | D22 | | | |
| AEA8 | E21 | | | |
| AEA7 | E22 | | | |
| AEA6 | F21 | | | |
| AEA5 | M20 | | | |
| AEA4 | J19 | | | |
| AEA3 | L20 | | | |
| EMIFA (32-BIT) – DATA | | | | |
| AED31 | W21 | I/O/Z | IPU | EMIFA external data |
| AED30 | W22 | | | |
| AED29 | V20 | | | |
| AED28 | W20 | | | |
| AED27 | AA22 | | | |
| AED26 | Y20 | | | |
| AED25 | AA21 | | | |
| AED24 | AB22 | | | |
| AED23 | P20 | | | |
| AED22 | R22 | | | |
| AED21 | R21 | | | |
| AED20 | U21 | | | |
| AED19 | V21 | | | |
| AED18 | T20 | | | |
| AED17 | V22 | | | |
| AED16 | U20 | | | |
| AED15 | A18 | | | |
| AED14 | D17 | | | |

† I = Input, O = Output, Z = High impedance, S = Supply voltage, GND = Ground, A = Analog Signal

‡ IPD = Internal pulldown, IPU = Internal pullup. (These IPD/IPU signal pins feature a 30-k Ω IPD or IPU resistor. To pull up a signal to the opposite supply rail, a 1-k Ω resistor should be used.)

§ These pins are multiplexed pins. For more details, see the Device Configurations section of this data sheet.

Table 3–9. Terminal Functions (Continued)

| NAME | NO. | TYPE† | IPD/ IPU‡ | DESCRIPTION |
|--|------|-------|--------------|--|
| EMIFA (32-BIT) – DATA (CONTINUED) | | | | |
| AED13 | B18 | I/O/Z | IPU | EMIFA external data |
| AED12 | C18 | | | |
| AED11 | A19 | | | |
| AED10 | C19 | | | |
| AED9 | B19 | | | |
| AED8 | A21 | | | |
| AED7 | D15 | | | |
| AED6 | A15 | | | |
| AED5 | B15 | | | |
| AED4 | C15 | | | |
| AED3 | A16 | | | |
| AED2 | C16 | | | |
| AED1 | B16 | | | |
| AED0 | C17 | | | |
| TIMER 2 | | | | |
| | – | | | No external pins. The timer 2 peripheral pins are <i>not</i> pinned out as external pins. |
| TIMER 1 | | | | |
| TOUT1/LENDIAN | AA1 | I/O/Z | IPU | Timer 1 output (O/Z) or device endian mode (I). Also controls initialization of DSP modes at reset via pullup/pulldown resistors – Device Endian mode 0 – Big Endian 1 – Little Endian (default) For more details on LENDIAN, see the Device Configurations section of this data sheet. |
| TINP1 | AB1 | I | IPD | Timer 1 or general-purpose input |
| TIMER 0 | | | | |
| TOUT0/HPI_EN | AA2 | I/O/Z | IPD | Timer 0 output pin and HPI enable $\overline{\text{HPI_EN}}$ pin function The $\overline{\text{HPI_EN}}$ pin function selects whether the HPI peripheral or McASP1 peripheral, and GP0[15:8] pins are functionally enabled 0 – HPI is enabled and the McASP1 peripheral and GP0 [15:8] pins are disabled (default mode); [HPI32, if HD5 = 1; HPI16 if HD5 = 0] 1 – HPI I is disabled and the McASP1 peripheral and GP0 [15:8] pins are enabled For more details, see the Device Configurations section of this data sheet. |
| TINP0 | AB2 | I | IPD | Timer 0 or general-purpose input |
| INTER-INTEGRATED CIRCUIT 1 (I2C1) | | | | |
| SCL1 | AA18 | I/O/Z | — | I2C1 clock. When the I2C module is used, use an external pullup resistor on this pin. |
| SDA1 | AA19 | I/O/Z | — | I2C1 data. When I2C is used, ensure there is an external pullup resistors on this pin. |
| INTER-INTEGRATED CIRCUIT 0 (I2C0) | | | | |
| SCL0 | AB18 | I/O/Z | — | I2C0 clock. When I2C is used, ensure there is an external pullup resistors on this pin. |
| SDA0 | AB19 | I/O/Z | — | I2C0 data. When I2C is used, ensure there is an external pullup resistors on this pin. |

† I = Input, O = Output, Z = High impedance, S = Supply voltage, GND = Ground, A = Analog Signal

‡ IPD = Internal pulldown, IPU = Internal pullup. (These IPD/IPU signal pins feature a 30-k Ω IPD or IPU resistor. To pull up a signal to the opposite supply rail, a 1-k Ω resistor should be used.)

§ These pins are multiplexed pins. For more details, see the Device Configurations section of this data sheet.

Table 3–9. Terminal Functions (Continued)

| NAME | NO. | TYPE† | IPD/ IPU‡ | DESCRIPTION |
|---|-----|-------|--------------|---|
| MULTICHANNEL BUFFERED SERIAL PORT 1 (McBSP1) | | | | |
| CLKR1 | G3 | I/O/Z | IPD | McBSP1 receive clock |
| FSR1 | G2 | I/O/Z | IPD | McBSP1 receive frame sync |
| DR1 | F1 | I | IPD | McBSP1 receive data |
| CLKS1 | G1 | I | IPD | McBSP1 external clock source (as opposed to internal) |
| DX1 | H2 | O/Z | IPD | McBSP1 transmit data |
| FSX1 | H3 | I/O/Z | IPD | McBSP1 transmit frame sync |
| CLKX1 | H1 | I/O/Z | IPD | McBSP1 transmit clock |
| MULTICHANNEL BUFFERED SERIAL PORT 0 (McBSP0) | | | | |
| CLKR0 | C2 | I/O/Z | IPD | McBSP0 receive clock |
| FSR0 | D1 | I/O/Z | IPD | McBSP0 receive frame sync |
| DR0 | D2 | I | IPD | McBSP0 receive data |
| CLKS0 | D3 | I | IPD | McBSP0 external clock source (as opposed to internal) |
| DX0 | E2 | O/Z | IPD | McBSP0 transmit data |
| FSX0 | E4 | I/O/Z | IPD | McBSP0 transmit frame sync |
| CLKX0 | E3 | I/O/Z | IPD | McBSP0 transmit clock |
| MULTICHANNEL AUDIO SERIAL PORT 0 (McASP0) | | | | |
| AHCLKX0 | N1 | I/O/Z | IPD | McASP0 transmit high-frequency master clock. |
| AFSX0 | M2 | I/O/Z | IPD | McASP0 transmit frame sync or left/right clock (LRCLK). |
| ACLKX0 | M1 | I/O/Z | IPD | McASP0 transmit bit clock. |
| AMUTE0 | K4 | I/O/Z | IPD | McASP0 mute output. |
| AMUTEIN0 | J4 | I | IPD | McASP0 mute input. |
| AHCLKR0 | L1 | I/O/Z | IPD | McASP0 receive high-frequency master clock. |
| AFSR0 | K2 | I/O/Z | IPD | McASP0 receive frame sync or left/right clock (LRCLK). |
| ACLKR0 | K1 | I/O/Z | IPD | McASP0 receive bit clock. |
| AXR0[5] | P3 | I/O/Z | IPD | McASP0 TX/RX data pin [5]. |
| AXR0[4] | N3 | | | McASP0 TX/RX data pin [4]. |
| AXR0[3] | M3 | | | McASP0 TX/RX data pins [3]. |
| AXR0[2] | L3 | | | McASP0 TX/RX data pin [2]. |
| AXR0[1] | K3 | | | McASP0 TX/RX data pin [1]. |
| AXR0[0] | L2 | | | McASP0 TX/RX data pins[0]. |

† I = Input, O = Output, Z = High impedance, S = Supply voltage, GND = Ground, A = Analog Signal

‡ IPD = Internal pulldown, IPU = Internal pullup. (These IPD/IPU signal pins feature a 30-k Ω IPD or IPU resistor. To pull up a signal to the opposite supply rail, a 1-k Ω resistor should be used.)

§ These pins are multiplexed pins. For more details, see the Device Configurations section of this data sheet.

Table 3–9. Terminal Functions (Continued)

| NAME | NO. | TYPE† | IPD/ IPU‡ | DESCRIPTION |
|----------------------------------|------|-------|--------------|--|
| MCASP1 | | | | |
| HCNTL0/AFSR1[1] | Y6 | I | IPU | Host control – selects between control, address, or data registers (I) [default] or McASP1 receive frame sync input 1 (I). |
| HHWIL/AFSR1[2] | Y7 | | | Host half-word select – first or second half-word (not necessarily high or low order) [For HPI16 bus width selection only] (I) [default] or McASP1 receive frame sync input 2 (I). |
| HR/ \overline{W} /AFSR1[3] | AA5 | | | Host read or write select (I) [default] or McASP1 receive frame sync input 3 (I). |
| \overline{HAS} /ACLKR1[1] | Y5 | | | Host address strobe (I) [default] or McASP1 receive clock input 1 (I). |
| \overline{HCS} /ACLKR1[2] | AA11 | | | Host chip select (I) [default] or McASP1 receive clock input 2 (I). |
| $\overline{HDS1}$ /ACLKR1[3] | AB11 | | | Host data strobe 1 (I) [default] or McASP1 receive clock input 3 (I). |
| HD27/AHCLKX1 | Y4 | | | I/O/Z |
| HD22/AFSX1 | AB5 | I/O/Z | IPU | Host-port data pin 22 (I/O/Z) [default] or McASP1 transmit frame sync or left/right clock (LRCLK) (I/O/Z). |
| HD24/ACLKX1 | AA4 | I/O/Z | IPU | Host-port data pin 24 (I/O/Z) [default] or McASP1 transmit bit clock (I/O/Z). |
| HD28/AMUTE1 | W10 | I/O/Z | IPU | Host-port data pin 28 (I/O/Z) [default] or McASP1 mute output (I/O/Z). |
| HD29/AMUTEIN1 | W11 | I | IPU | Host-port data pin 29 (I/O/Z) [default] or McASP1 mute input (I). |
| HD26/AHCLKR1 | AB4 | I/O/Z | IPU | Host-port data pin 26 (I/O/Z) [default] or McASP1 receive high-frequency master clock (I/O/Z). |
| HD23/AFSR1 | AB9 | I/O/Z | IPU | Host-port data pin 23 (I/O/Z) [default] or McASP1 receive frame sync or left/right clock (LRCLK) (I/O/Z). |
| HD25/ACLKR1 | AA9 | I/O/Z | IPU | Host-port data pin 25 (I/O/Z) [default] or McASP1 receive bit clock (I/O/Z). |
| HD21/AXR1[5] | Y9 | I/O/Z | IPU | Host-port data pins [21:16] (I/O/Z) [default] or McASP1 TX/RX data pins [5:0] (I/O/Z). |
| HD20/AXR1[4] | AB8 | | | |
| HD19/AXR1[3] | AA6 | | | |
| HD18/AXR1[2] | AB7 | | | |
| HD17/AXR1[1] | AA7 | | | |
| HD16/AXR1[0] | AB6 | | | |
| HOST-PORT INTERFACE (HPI) | | | | |
| \overline{HINT} | AA8 | O/Z | IPU | Host interrupt from DSP to host (O) |
| HCNTL1 | W7 | I | IPU | Host control – selects between control, address, or data registers (I) |
| HCNTL0/AFSR1[1] | Y6 | I | IPU | Host control – selects between control, address, or data registers (I) [default] or McASP1 receive frame sync input 1 (I). |
| HHWIL/AFSR1[2] | Y7 | | | Host half-word select – first or second half-word (not necessarily high or low order) [For HPI16 bus width selection only] (I) [default] or McASP1 receive frame sync input 2 (I). |
| HR/ \overline{W} /AFSR1[3] | AA5 | | | Host read or write select (I) [default] or McASP1 receive frame sync input 3 (I). |
| \overline{HAS} /ACLKR1[1] | Y5 | | | Host address strobe (I) [default] or McASP1 receive clock input 1 (I). |
| \overline{HCS} /ACLKR1[2] | AA11 | | | Host chip select (I) [default] or McASP1 receive clock input 2 (I). |
| $\overline{HDS1}$ /ACLKR1[3] | AB11 | | | Host data strobe 1 (I) [default] or McASP1 receive clock input 3 (I). |
| $\overline{HDS2}$ | AB12 | | | I |
| HRDY | Y10 | O/Z | IPU | Host ready from DSP to host (O) |

† I = Input, O = Output, Z = High impedance, S = Supply voltage, GND = Ground, A = Analog Signal

‡ IPD = Internal pulldown, IPU = Internal pullup. (These IPD/IPU signal pins feature a 30-k Ω IPD or IPU resistor. To pull up a signal to the opposite supply rail, a 1-k Ω resistor should be used.)

§ These pins are multiplexed pins. For more details, see the Device Configurations section of this data sheet.

Table 3–9. Terminal Functions (Continued)

| NAME | NO. | TYPE† | IPD/ IPU‡ | DESCRIPTION |
|--|------|-------|--------------|--|
| HOST-PORT INTERFACE (HPI) (CONTINUED) | | | | |
| HD31 | Y8 | I/O/Z | IPU | Host-port data pin 31 (I/O/Z) |
| HD30 | Y11 | I/O/Z | IPU | Host-port data pin 30 (I/O/Z) |
| HD29/AMUTEIN1 | W11 | I | IPU | Host-port data pin 29 (I/O/Z) [default] or McASP1 mute input (I). |
| HD28/AMUTE1 | W10 | I/O/Z | IPU | Host-port data pin 28 (I/O/Z) [default] or McASP1 mute output (I/O/Z). |
| HD27/AHCLKX1 | Y4 | I/O/Z | IPU | Host-port data pin 27 (I/O/Z) [default] or McASP1 transmit high-frequency master clock (I/O/Z). |
| HD26/AHCLKR1 | AB4 | I/O/Z | IPU | Host-port data pin 26 (I/O/Z) [default] or McASP1 receive high-frequency master clock (I/O/Z). |
| HD25/ACLKR1 | AA9 | I/O/Z | IPU | Host-port data pin 25 (I/O/Z) [default] or McASP1 receive bit clock (I/O/Z). |
| HD24/ACLKX1 | AA4 | I/O/Z | IPU | Host-port data pin 24 (I/O/Z) [default] or McASP1 transmit bit clock (I/O/Z). |
| HD23/AFSR1 | AB9 | I/O/Z | IPU | Host-port data pin 23 (I/O/Z) [default] or McASP1 receive frame sync or left/right clock (LRCLK) (I/O/Z). |
| HD22/AFSX1 | AB5 | I/O/Z | IPU | Host-port data pin 22 (I/O/Z) [default] or McASP1 transmit frame sync or left/right clock (LRCLK) (I/O/Z). |
| HD21/AXR1[5] | Y9 | I/O/Z | IPU | Host-port data [21:16] pin (I/O/Z) [default] or McASP1 TX/RX data pins [5:0] (I/O/Z). |
| HD20/AXR1[4] | AB8 | | | |
| HD19/AXR1[3] | AA6 | | | |
| HD18/AXR1[2] | AB7 | | | |
| HD17/AXR1[1] | AA7 | | | |
| HD16/AXR1[0] | AB6 | | | |
| HD15/GP0[15] | Y12 | I/O/Z | IPU | Host-port data [15:8] pins (I/O/Z) [default] or General-purpose input/output (GP0) [15:8] pins (I/O/Z). |
| HD14/GP0[14] | AA12 | | | |
| HD13/GP0[13] | AB13 | | | |
| HD12/GP0[12] | Y14 | | | |
| HD11/GP0[11] | AB14 | | | |
| HD10/GP0[10] | AA15 | | | |
| HD9/GP0[9] | Y16 | | | |
| HD8/GP0[8] | AB16 | | | |
| HD7 | W12 | I/O/Z | IPU | Host-port data [7:0] pins (I/O/Z) |
| HD6 | AA13 | | | Host-Port bus width user-configurable at device reset via a 1-k Ω pullup/pulldown resistor on the HD5 pin (I): HD5 pin = 0: HPI operates as an HPI16. (HPI bus is 16 bits wide. HD[15:0] pins are used and the remaining HD[31:16] pins are reserved pins in the high-impedance state.) HD5 pin = 1: HPI operates as an HPI32. (HPI bus is 32 bits wide. All HD[31:0] pins are used for host-port operations.) |
| HD5 | Y13 | | | |
| HD4 | AA14 | | | |
| HD3 | AB15 | | | |
| HD2 | AA16 | | | |
| HD1 | Y15 | | | |
| HD0 | W15 | | | |

† I = Input, O = Output, Z = High impedance, S = Supply voltage, GND = Ground, A = Analog Signal

‡ IPD = Internal pulldown, IPU = Internal pullup. (These IPD/IPU signal pins feature a 30-k Ω IPD or IPU resistor. To pull up a signal to the opposite supply rail, a 1-k Ω resistor should be used.)

§ These pins are multiplexed pins. For more details, see the Device Configurations section of this data sheet.

Table 3–9. Terminal Functions (Continued)

| SIGNAL NAME | NO. | TYPE† | IPD/ IPU‡ | DESCRIPTION |
|----------------------------|-----|-------|-----------|---|
| RESERVED FOR TEST | | | | |
| RSV | U4 | A | — | Reserved. This pin must be connected directly to CV _{DD} for proper device operation. |
| RSV | F3 | A | — | Reserved. This pin must be connected directly to DV _{DD} for proper device operation. |
| RSV | C8 | I | IPD | Reserved. This pin must be connected directly to V _{SS} for proper device operation. |
| RSV | B11 | A | — | Reserved (leave unconnected, do not connect to power or ground). If the signal must be routed from the device, the internal pull-up/down resistance should not be relied upon and an external pull-up/down should be used. |
| | B12 | I | — | |
| | C10 | O | IPU | |
| | D7 | O/Z | — | |
| | D8 | O/Z | — | |
| SUPPLY VOLTAGE PINS | | | | |
| DV _{DD} | A3 | S | | 3.3-V supply voltage (see the Power-Supply Decoupling section of this data manual) |
| | A5 | | | |
| | A8 | | | |
| | A9 | | | |
| | A14 | | | |
| | A17 | | | |
| | A20 | | | |
| | B1 | | | |
| | C22 | | | |
| | E1 | | | |
| | G22 | | | |
| | J1 | | | |
| | M22 | | | |
| | P1 | | | |
| | T22 | | | |
| | W1 | | | |
| | Y2 | | | |
| | Y17 | | | |
| | Y19 | | | |
| | Y22 | | | |
| AB3 | | | | |
| AB10 | | | | |
| AB17 | | | | |
| AB20 | | | | |

† I = Input, O = Output, Z = High impedance, S = Supply voltage, GND = Ground, A = Analog Signal

‡ IPD = Internal pulldown, IPU = Internal pullup. (These IPD/IPU signal pins feature a 30-k Ω IPD or IPU resistor. To pull up a signal to the opposite supply rail, a 1-k Ω resistor should be used.)

Table 3–9. Terminal Functions (Continued)

| SIGNAL NAME | NO. | TYPE† | IPD/ IPU‡ | DESCRIPTION |
|--|-----|-------|--------------|--|
| SUPPLY VOLTAGE PINS (CONTINUED) | | | | |
| CVDD | D5 | S | | 1.2-V supply voltage (A-500 device) 1.4-V supply voltage (-600 device) (see the Power-Supply Decoupling section of this data manual) |
| | D6 | | | |
| | D9 | | | |
| | D11 | | | |
| | D12 | | | |
| | D14 | | | |
| | D18 | | | |
| | E19 | | | |
| | F19 | | | |
| | G4 | | | |
| | H4 | | | |
| | L19 | | | |
| | M4 | | | |
| | M19 | | | |
| | N4 | | | |
| | V4 | | | |
| | V19 | | | |
| | W5 | | | |
| W9 | | | | |
| W13 | | | | |
| W16 | | | | |
| W18 | | | | |
| GROUND PINS | | | | |
| VSS | A1 | GND | | Ground pins |
| | A10 | | | |
| | B2 | | | |
| | B5 | | | |
| | B8 | | | |
| | B14 | | | |
| | B17 | | | |
| | B20 | | | |
| | C1 | | | |
| | C3 | | | |
| | C5 | | | |
| | C7 | | | |

† I = Input, O = Output, Z = High impedance, S = Supply voltage, GND = Ground, A = Analog Signal

‡ IPD = Internal pulldown, IPU = Internal pullup. (These IPD/IPU signal pins feature a 30-k Ω IPD or IPU resistor. To pull up a signal to the opposite supply rail, a 1-k Ω resistor should be used.)

Table 3–9. Terminal Functions (Continued)

| SIGNAL NAME | NO. | TYPE† | IPD/ IPU‡ | DESCRIPTION |
|-------------------------|-----|-------|--------------|-------------|
| GROUND PINS (CONTINUED) | | | | |
| VSS | C14 | GND | | Ground pins |
| | C21 | | | |
| | D4 | | | |
| | D10 | | | |
| | D19 | | | |
| | F2 | | | |
| | F4 | | | |
| | G19 | | | |
| | G21 | | | |
| | J2 | | | |
| | J3 | | | |
| | K19 | | | |
| | L4 | | | |
| | L22 | | | |
| | N2 | | | |
| | N19 | | | |
| | P4 | | | |
| | T21 | | | |
| | U19 | | | |
| | W4 | | | |
| | W6 | | | |
| | W8 | | | |
| | W14 | | | |
| | W17 | | | |
| W19 | | | | |
| Y3 | | | | |
| Y18 | | | | |
| Y21 | | | | |
| AA3 | | | | |
| AA10 | | | | |
| AA17 | | | | |
| AA20 | | | | |

† I = Input, O = Output, Z = High impedance, S = Supply voltage, GND = Ground, A = Analog Signal

‡ IPD = Internal pulldown, IPU = Internal pullup. (These IPD/IPU signal pins feature a 30-k Ω IPD or IPU resistor. To pull up a signal to the opposite supply rail, a 1-k Ω resistor should be used.)

3.11 Development Support

In case the customer would like to develop their own features and software on the TMS320C6418 device, TI offers an extensive line of development tools for the TMS320C6000™ DSP platform, including tools to evaluate the performance of the processors, generate code, develop algorithm implementations, and fully integrate and debug software and hardware modules. The tool's support documentation is electronically available within the Code Composer Studio™ Integrated Development Environment (IDE).

The following products support development of C6000™ DSP-based applications:

Software Development Tools:

Code Composer Studio™ Integrated Development Environment (IDE): including Editor C/C++/Assembly Code Generation, and Debug plus additional development tools Scalable, Real-Time Foundation Software (DSP/BIOS™), which provides the basic run-time target software needed to support any DSP application.

Hardware Development Tools:

Extended Development System (XDS™) Emulator (supports C6000™ DSP multiprocessor system debug) EVM (Evaluation Module)

For a complete listing of development-support tools for the TMS320C6000™ DSP platform, visit the Texas Instruments web site on the Worldwide Web at <http://www.ti.com> uniform resource locator (URL). For information on pricing and availability, contact the nearest TI field sales office or authorized distributor.

Code Composer Studio, DSP/BIOS, and XDS are trademarks of Texas Instruments.

3.12 Device Support

3.12.1 Device and Development-Support Tool Nomenclature

To designate the stages in the product development cycle, TI assigns prefixes to the part numbers of all DSP devices and support tools. Each DSP commercial family member has one of three prefixes: TMX, TMP, or TMS (e.g., **TMS320C6412GDK600**). Texas Instruments recommends two of three possible prefix designators for its support tools: TMDX and TMDS. These prefixes represent evolutionary stages of product development from engineering prototypes (TMX/TMDX) through fully qualified production devices/tools (TMS/TMDS).

Device development evolutionary flow:

- TMX** Experimental device that is not necessarily representative of the final device's electrical specifications.
- TMP** Final silicon die that conforms to the device's electrical specifications but has not completed quality and reliability verification.
- TMS** Fully qualified production device.

Support tool development evolutionary flow:

- TMDX** Development-support product that has not yet completed Texas Instruments internal qualification testing.
- TMDS** Fully qualified development-support product.

TMX and TMP devices and TMDX development-support tools are shipped against the following disclaimer:

"Developmental product is intended for internal evaluation purposes."

TMS devices and TMDS development-support tools have been characterized fully, and the quality and reliability of the device have been demonstrated fully. TI's standard warranty applies.

Predictions show that prototype devices (TMX or TMP) have a greater failure rate than the standard production devices. Texas Instruments recommends that these devices not be used in any production system because their expected end-use failure rate still is undefined. Only qualified production devices are to be used.

TI device nomenclature also includes a suffix with the device family name. This suffix indicates the package type (for example, GTS), the temperature range (for example, "A" is the extended commercial temperature range), and the device speed range in megahertz (for example, -500 is 500 MHz). Figure 3–7 provides a legend for reading the complete device name for any TMS320C6000™ DSP platform member.

The ZTS package, like the GTS package, is a 288-ball plastic BGA *only* with Pb-free balls. For device part numbers and further ordering information for TMS320C6418 in the GTS and ZTS package types, see the TI website (<http://www.ti.com>) or contact your TI sales representative.

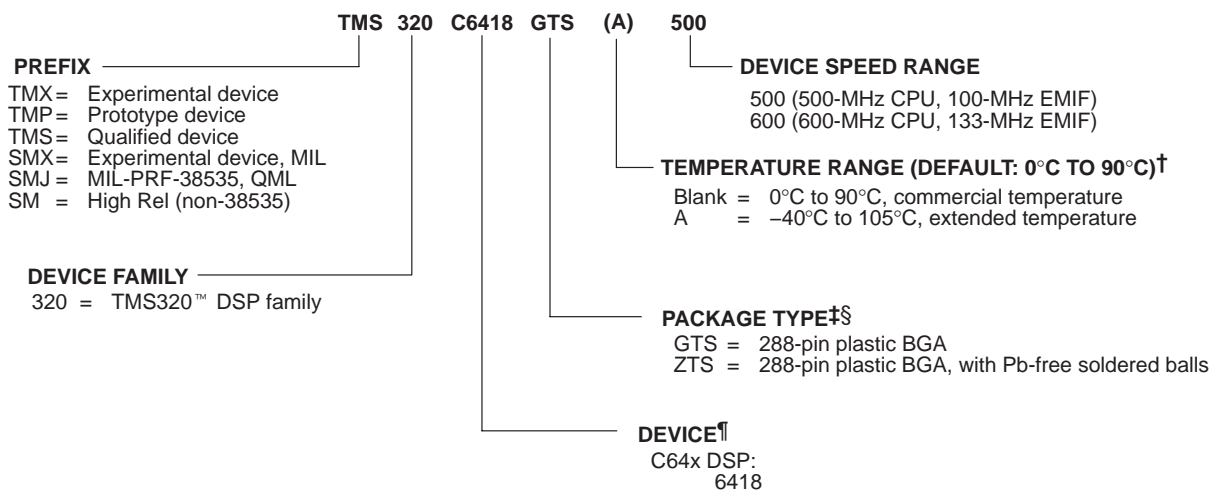

† The extended temperature "A version" devices may have different operating conditions than the commercial temperature devices.

For more details, see the recommended operating conditions portion of this data sheet.

‡ BGA = Ball Grid Array

§ The ZTS mechanical package designator represents the version of the GTS package with Pb-free balls. For more detailed information, see the *Mechanical Data* section of this document.

¶ For actual device part numbers (P/Ns) and ordering information, see the TI website (www.ti.com).

Figure 3–7. TMS320C6418 DSP Device Nomenclature

For additional information, see the *TMS320C6418 Digital Signal Processor Silicon Errata* (literature number SPRZ224).

3.12.2 Documentation Support

Extensive documentation supports all TMS320™ DSP family generations of devices from product announcement through applications development. The types of documentation available include: data sheets, such as this document, with design specifications; complete user's reference guides for all devices and tools; technical briefs; development-support tools; on-line help; and hardware and software applications. The following is a brief, descriptive list of support documentation specific to the C6000™ DSP devices:

The *TMS320C6000 CPU and Instruction Set Reference Guide* (literature number SPRU189) describes the C6000™ DSP CPU (core) architecture, instruction set, pipeline, and associated interrupts.

The *TMS320C6000 DSP Peripherals Overview Reference Guide* (literature number SPRU190) provides an overview and briefly describes the functionality of the peripherals available on the C6000™ DSP platform of devices. This document also includes a table listing the peripherals available on the C6000 devices along with literature numbers and hyperlinks to the associated peripheral documents.

The *TMS320C64x Technical Overview* (literature number SPRU395) gives an introduction to the C64x™ digital signal processor, and discusses the application areas that are enhanced by the C64x™ DSP *VelociTI.2™* VLIW architecture.

The *TMS320C64x DSP Viterbi-Decoder Coprocessor Reference Guide* (literature number SPRU533) describes the functionality of the Viterbi-Decoder Coprocessor (VCP).

The *TMS320C6000 DSP Multichannel Audio Serial Port (McASP) Reference Guide* (literature number SPRU041) describes the functionality of the McASP peripheral.

The *TMS320C6000 DSP Inter-Integrated Circuit (I2C) Module Reference Guide* (literature number SPRU175) describes the functionality of the I2C peripherals available on the C6418 device except for the additional interrupt and new GPIO capability. For more detailed information on the additional interrupt and GPIO capability, see the *I2C* section of this data manual and the *TMS320C6410/C6413/C6418 DSP Inter-Integrated Circuit (I2C) Module Reference Guide* (literature number SPRZ221).

The *TMS320C6418 Digital Signal Processor Silicon Errata* (literature number SPRZ224) describes the known exceptions to the functional specifications for particular silicon revisions of the TMS320C6418 device.

The *Using IBIS Models for Timing Analysis* application report (literature number SPRA839) describes how to properly use IBIS models to attain accurate timing analysis for a given system.

The tools support documentation is electronically available within the Code Composer Studio™ Integrated Development Environment (IDE). For a complete listing of C6000™ DSP latest documentation, visit the Texas Instruments web site on the Worldwide Web at <http://www.ti.com> uniform resource locator (URL).

4 Peripherals Detailed Description (Device-Specific)

4.1 Clock PLL and Oscillator

Most of the internal C64x™ DSP clocks are generated from a single source through the CLKIN pin. This source clock either drives the PLL, which multiplies the source clock frequency to generate the internal CPU clock, or bypasses the PLL to become the internal CPU clock.

To use the PLL to generate the CPU clock, the external PLL filter circuit must be properly designed. Figure 4–1 shows the external PLL circuitry for either x1 (PLL bypass) or other PLL multiply modes.

To minimize the clock jitter, a single clean power supply should power both the C64x™ DSP device and the external clock oscillator circuit. The minimum CLKIN rise and fall times should also be observed. For the input clock timing requirements, see the *input and output clocks* electricals section.

Rise/fall times, duty cycles (high/low pulse durations), and the load capacitance of the external clock source must meet the DSP requirements in this data sheet (see the *electrical characteristics over recommended ranges of supply voltage and operating case temperature* table and the *input and output clocks* electricals section).

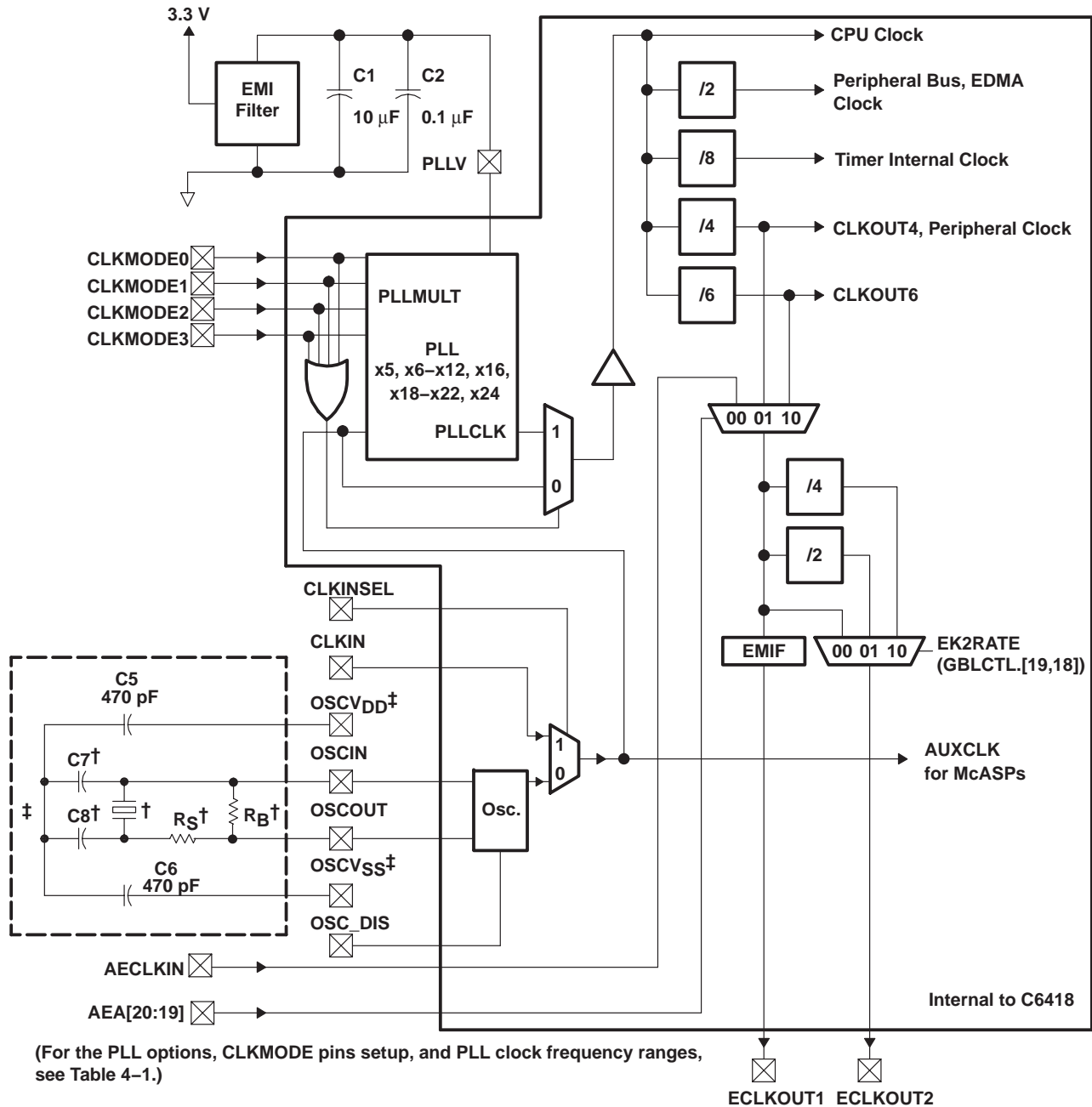

(For the PLL options, CLKMODE pins setup, and PLL clock frequency ranges, see Table 4-1.)

† Exact values for these components depend on choice of crystal. For recommended crystal and component values, see Table 4-3.
 ‡ Do not connect any of these nodes to board power or ground if the oscillator is used. They are internally connected for proper operation. If CLKIN is being used instead of the oscillator, then OSCV_{DD} and OSCV_{SS} may either be left open, or OSCV_{DD} may be tied to CV_{DD} and OSCV_{SS} may be tied to ground.

- NOTES:
- A. Place all PLL external components (C1, C2, and the EMI Filter) as close to the C6000™ DSP device as possible. For the best performance, TI recommends that all the PLL external components be on a single side of the board without jumpers, switches, or components other than the ones shown.
 - B. For reduced PLL jitter, maximize the spacing between switching signals and the PLL external components (C1, C2, and the EMI Filter).
 - C. The 3.3-V supply for the EMI filter must be from the same 3.3-V power plane supplying the I/O voltage, DV_{DD}.
 - D. EMI filter manufacturer TDK part number ACF451832-333, -223, -153, -103. Panasonic part number EXCCET103U.
 - E. If CLKIN is used instead of the oscillator, tie OSCIN to Ground to minimize noise and current. (Do not leave OSCIN floating.)

Figure 4-1. External PLL Circuitry for Either PLL Multiply Modes or x1 (Bypass) Mode

For proper C6418 device operation, the CLKINSEL pin **must** be used in conjunction with the OSC_DIS pin. The OSC_DIS pin **must** follow the CLKINSEL pin operation. For more details on these two configuration pins, see the *Device Configuration at Device Reset* section of this data sheet.

Table 4–1. TMS320C6418 PLL Multiply Factor Options, Clock Frequency Ranges, and Typical Lock Time for –600 Devices†

| GTS and ZTS PACKAGES – 23 x 23 mm BGA | | | | | | | | | |
|---------------------------------------|---|---|---|-----------------------------------|-------------------------|--|-------------------------|--|-------------------------------------|
| CLKMODE[3:0] | | | | CLKMODE (PLL MULTIPLY FACTORS) | CLKIN RANGE (MHz) | CPU CLOCK FREQUENCY RANGE (MHz) | OSCIN RANGE (MHz) | CPU CLOCK FREQUENCY RANGE (MHz) | TYPICAL LOCK TIME (μ s)‡ |
| 0 | 0 | 0 | 0 | Bypass (x1) | 12–100 | 12–100 | 12–30 | 12–30 | N/A |
| 0 | 0 | 0 | 1 | x5 | 28–100 | 140–500 | 28–30 | 140–150 | 75 |
| 0 | 0 | 1 | 0 | x6 | 23–100 | 140–600 | 23–30 | 140–180 | |
| 0 | 0 | 1 | 1 | x7 | 20–85 | 140–600 | 20–30 | 140–210 | |
| 0 | 1 | 0 | 0 | x8 | 17–75 | 140–600 | 17–30 | 140–240 | |
| 0 | 1 | 0 | 1 | x9 | 15–66 | 140–600 | 15–30 | 140–270 | |
| 0 | 1 | 1 | 0 | x10 | 14–60 | 140–600 | 14–30 | 140–300 | |
| 0 | 1 | 1 | 1 | x11 | 12–54 | 140–600 | 12–30 | 140–330 | |
| 1 | 0 | 0 | 0 | x12 | 12–50 | 144–600 | 12–30 | 144–360 | |
| 1 | 0 | 0 | 1 | x16 | 12–37 | 192–600 | 12–30 | 192–480 | |
| 1 | 0 | 1 | 0 | x18 | 12–33 | 216–600 | 12–30 | 216–540 | |
| 1 | 0 | 1 | 1 | x19 | 12–31 | 228–600 | 12–30 | 228–570 | |
| 1 | 1 | 0 | 0 | x20 | 12–30 | 240–600 | 12–30 | 240–600 | |
| 1 | 1 | 0 | 1 | x21 | 12–28 | 252–600 | 12–28 | 252–600 | |
| 1 | 1 | 1 | 0 | x22 | 12–27 | 264–600 | 12–27 | 264–600 | |
| 1 | 1 | 1 | 1 | x24 | 12–25 | 288–600 | 12–25 | 288–600 | |

† Use external pullup resistors on the CLKMODE pins (CLKMODE1 and CLKMODE0) to set the C6418 device to one of the valid PLL multiply clock modes (x5, x6, x7, x8, x9, x10, x11, x12, x16, x18, x19, x20, x21, x22, or x24). With internal pulldown resistors on the CLKMODE pins (CLKMODE3, CLKMODE2, CLKMODE1, CLKMODE0), the default clock mode is x1 (bypass).

‡ Under some operating conditions, the maximum PLL lock time may vary by as much as 150% from the specified typical value. For example, if the typical lock time is specified as 100 μ s, the maximum value may be as long as 250 μ s.

Table 4–2. TMS320C6418 PLL Multiply Factor Options, Clock Frequency Ranges, and Typical Lock Time for –500 Devices†

| GTS and ZTS PACKAGES – 23 x 23 mm BGA | | | | | | | | | |
|---------------------------------------|---|---|---|-----------------------------------|-------------------------|--|-------------------------|--|-------------------------------------|
| CLKMODE[3:0] | | | | CLKMODE (PLL MULTIPLY FACTORS) | CLKIN RANGE (MHz) | CPU CLOCK FREQUENCY RANGE (MHz) | OSCIN RANGE (MHz) | CPU CLOCK FREQUENCY RANGE (MHz) | TYPICAL LOCK TIME (μ s)‡ |
| 0 | 0 | 0 | 0 | Bypass (x1) | 12–100 | 12–100 | 12–30 | 12–30 | N/A |
| 0 | 0 | 0 | 1 | x5 | 28–100 | 140–500 | 28–30 | 140–150 | 75 |
| 0 | 0 | 1 | 0 | x6 | 23–83 | 140–500 | 23–30 | 140–180 | |
| 0 | 0 | 1 | 1 | x7 | 20–71 | 140–500 | 20–30 | 140–210 | |
| 0 | 1 | 0 | 0 | x8 | 17–63 | 140–500 | 17–30 | 140–240 | |
| 0 | 1 | 0 | 1 | x9 | 15–56 | 140–500 | 15–30 | 140–270 | |
| 0 | 1 | 1 | 0 | x10 | 14–50 | 140–500 | 14–30 | 140–300 | |
| 0 | 1 | 1 | 1 | x11 | 12–45 | 140–500 | 12–30 | 140–330 | |
| 1 | 0 | 0 | 0 | x12 | 12–42 | 144–500 | 12–30 | 144–360 | |
| 1 | 0 | 0 | 1 | x16 | 12–31 | 192–500 | 12–30 | 192–480 | |
| 1 | 0 | 1 | 0 | x18 | 12–28 | 216–500 | 12–28 | 216–500 | |
| 1 | 0 | 1 | 1 | x19 | 12–26 | 228–500 | 12–26 | 228–500 | |
| 1 | 1 | 0 | 0 | x20 | 12–25 | 240–500 | 12–25 | 240–500 | |
| 1 | 1 | 0 | 1 | x21 | 12–24 | 252–500 | 12–24 | 252–500 | |
| 1 | 1 | 1 | 0 | x22 | 12–23 | 264–500 | 12–23 | 264–500 | |
| 1 | 1 | 1 | 1 | x24 | 12–21 | 288–500 | 12–21 | 288–500 | |

† Use external pullup resistors on the CLKMODE pins (CLKMODE1 and CLKMODE0) to set the C6418 device to one of the valid PLL multiply clock modes (x5, x6, x7, x8, x9, x10, x11, x12, x16, x18, x19, x20, x21, x22, or x24). With internal pulldown resistors on the CLKMODE pins (CLKMODE3, CLKMODE2, CLKMODE1, CLKMODE0), the default clock mode is x1 (bypass).

‡ Under some operating conditions, the maximum PLL lock time may vary by as much as 150% from the specified typical value. For example, if the typical lock time is specified as 100 μ s, the maximum value may be as long as 250 μ s.

For the lowest jitter on the oscillator circuit, it is recommended that a pair of 470-pF capacitors be connected between isolated (not directly connected to the board supply) OSCV_{DD} and OSCV_{SS} pins. This helps to cancel out switching noise from other circuits on the DSP device.

Table 4–3 shows a recommended crystal and tank circuit values for the C6418 PLL circuitry.

Table 4–3. Crystal and Tank Circuit Recommendations

| Components | RECOMMENDED PART NUMBERS or VALUES | | MANUFACTURER |
|----------------|------------------------------------|-----------------------|----------------------|
| Crystal | 24.576 MHz | 1AS245766AHA (SMD-49) | KDS™ Diashinku Corp. |
| | | 1AF245766AAA (AT-49) | |
| | 22.5792 MHz | 1AS225796AG (SMD-49) | |
| | | 1AF225796A (AT-49) | |
| R _B | 1 M Ω | | — |
| R _S | 0 Ω | | — |
| C7 C8 | 8 pF | | — |

4.2 Host-Port Interface (HPI) Peripheral

The TMS320C6418 device includes a user-configurable 16-bit or 32-bit Host-port interface (HPI16/HPI32). On the C6418 device the HPI peripheral pins are muxed with the McASP1 and GP0 peripheral pins. By default, the HPI peripheral pin functions are enabled. For more detailed information on the C6418 device pin muxing, see the Device Configurations section of this data sheet.

The HPI peripheral can be disabled or enabled at reset through the HPI enable function of the TOUT0/HPI_EN pin. The HPI is enabled when the TOUT0/HPI_EN pin is sampled low at reset and it is disabled if the pin is sample high at reset. The TOUT0/HPI_EN pin has an internal pulldown that enables the HPI by default. However, the HPI can be disabled via an external pullup resistor or by having an external device such as an FPGA/CPLD drive that pin high at reset. In the latter case, the external device should ensure it has stopped driving this pin to avoid contention. The HPI enable function can only be set a reset and cannot be changed via software.

The HD5 pin controls the HPI_WIDTH, allowing the user to configure the HPI as a 16-bit or 32-bit peripheral.

For more details on HPI peripheral configuration and the associated pins, see the Device Configurations section of this data sheet.

4.3 Multichannel Audio Serial Port (McASP) Peripheral

The TMS320C6418 device includes two multichannel audio serial port (McASP) interface peripheral (McASP0 and McASP1). On the C6418 device the McASP1 peripheral pins are muxed with the HPI peripheral pins. By default, the HPI peripheral pin functions are enabled. For the C6418 device McASP1 is a standalone peripheral, not muxed. For more detailed information on the C6418 device pin muxing, see the Device Configurations section of this data sheet.

The McASP is a serial port optimized for the needs of multichannel audio applications.

The McASP consists of a transmit and receive section. These sections can operate completely independently with different data formats, separate master clocks, bit clocks, and frame syncs or alternatively, the transmit and receive sections may be synchronized. The McASP module also includes a pool of 16 shift registers that may be configured to operate as either transmit data, receive data, or general-purpose I/O (GPIO).

The transmit section of the McASP can transmit data in either a time-division-multiplexed (TDM) synchronous serial format or in a digital audio interface (DIT) format where the bit stream is encoded for S/PDIF, AES-3, IEC-60958, CP-430 transmission. The receive section of the McASP supports the TDM synchronous serial format.

The McASP can support one transmit data format (either a TDM format or DIT format) and one receive format at a time. All transmit shift registers use the same format and all receive shift registers use the same format. However, the transmit and receive formats need not be the same.

Both the transmit and receive sections of the McASP also support burst mode which is useful for non-audio data (for example, passing control information between two DSPs).

The McASP peripheral has additional capability for flexible clock generation, and error detection/handling, as well as error management.

For more detailed information on and the functionality of the McASP peripheral, see the *TMS320C6000 DSP Multichannel Audio Serial Port (McASP) Reference Guide* (literature number SPRU041).

4.3.1 McASP Block Diagram

Figure 4–2 illustrates the major blocks along with external signals of the TMS320C6418 McASP peripheral; and shows the 6 serial data [AXRx] pins. The McASP also includes full general-purpose I/O (GPIO) control, so any pins not needed for serial transfers can be used for general-purpose I/O.

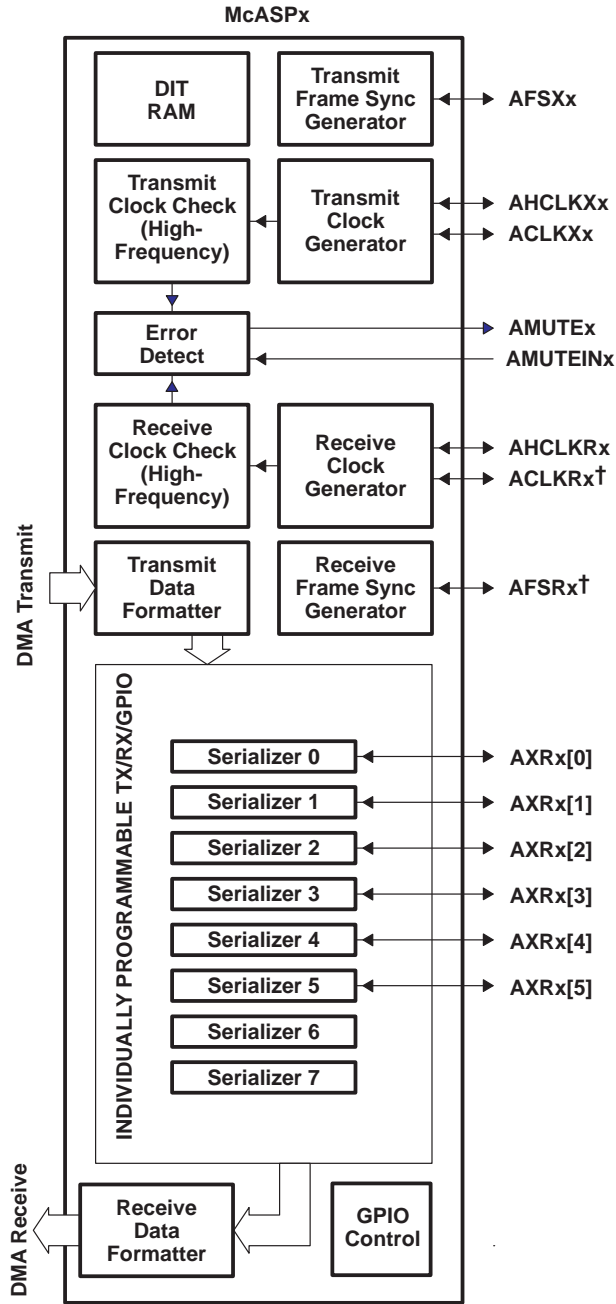

† On the C6418 device, the McASP1 peripheral has some additional pins muxed with AFSR1 and with ACLKR1 pins (i.e., AFSR1[1], AFSR1[2], AFSR1[3] and ACLKR1[1], ACLKR1[2], ACLKR1[3], respectively).

‡ On the C6418 device, the McASP0 peripheral is standalone, not muxed and the McASP1 peripheral is muxed with the HPI peripheral. For more detailed information on multiplexed pins, see the Device Configurations section of this data sheet.

Figure 4–2. McASP0 and McASP1‡ Configuration

4.4 I2C

The TMS320C6418 device includes two I2C peripheral modules (I2C0 and I2C1). NOTE: when using the I2C modules (any mode), ensure there are external pullup resistors on the SDAx and SCLx pins.

One of the I2C modules on the TMS320C6418 may be used by the DSP to control local peripherals ICs (DACs, ADCs, etc.) while the other module may be used to communicate with other controllers in a system or to implement a user interface.

The I2Cx port supports:

- Compatible with Philips I2C Specification Revision 2.1 (January 2000)
- Fast Mode up to 400 Kbps (no fail-safe I/O buffers)
- Noise Filter to remove noise 50 ns or less
- 7- and 10-Bit Device Addressing Modes
- Multi-Master (Transmit/Receive) and Slave (Transmit/Receive) Functionality
- Events: DMA, Interrupt, or Polling
- Slew-Rate Limited Open-Drain Output Buffers
- General-purpose input and output (GPIO) functionality for I2C pins

For more detailed information on C6418 I2C additional features, such as GPIO capability, etc., see the TMS320C6000 DSP Inter-Integrated Circuit (I2C) Module Reference Guide (literature number SPRU175) and the TMS320C6410/C6413/C6418 DSP Inter-Integrated Circuit (I2C) Module Reference Guide (literature number SPRZ221) addendum.

Figure 4–3 is a block diagram of the I2C0 and I2C1 modules.

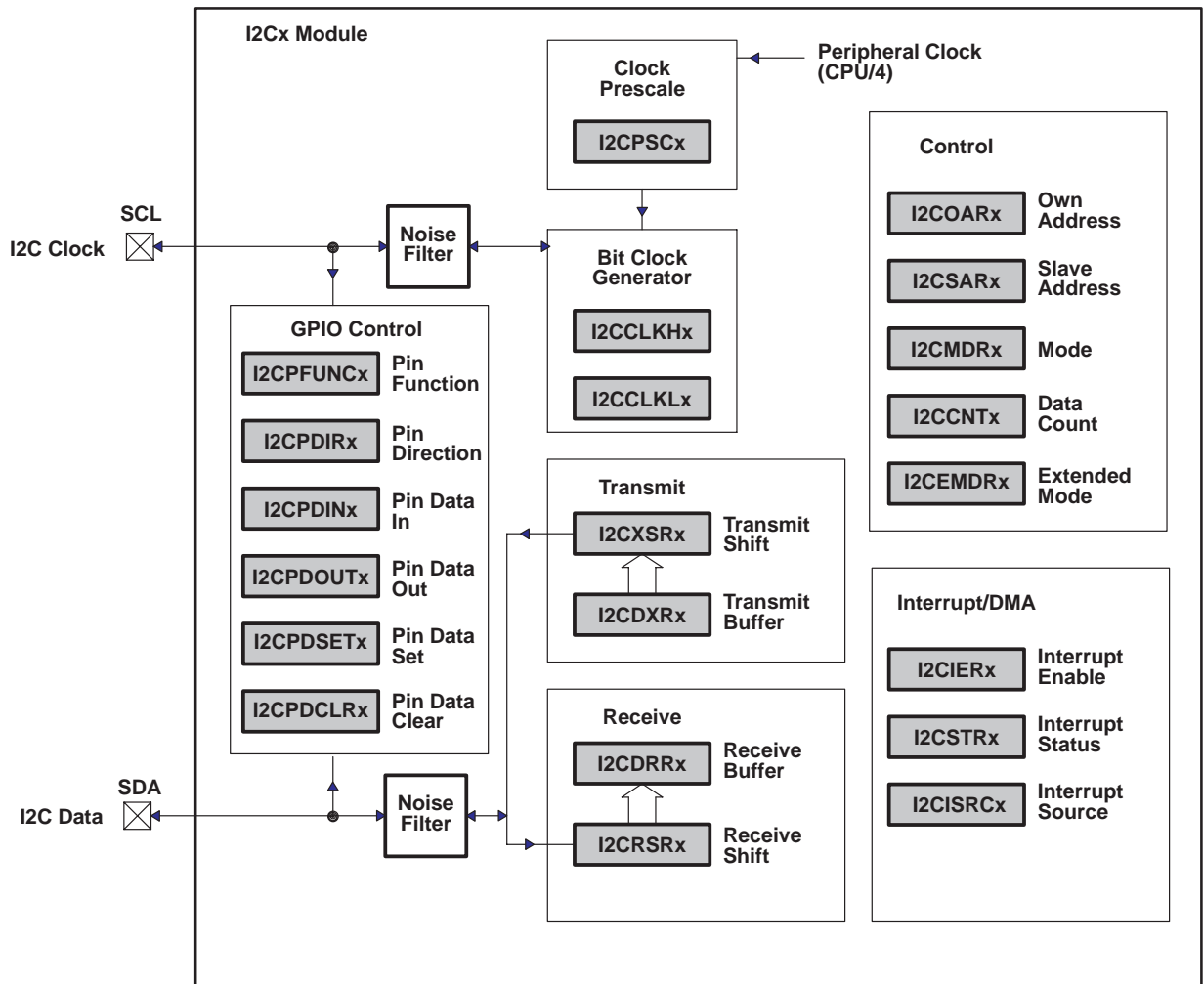

NOTE A: Shading denotes control/status registers.

Figure 4–3. I2Cx Module Block Diagram

4.5 Viterbi-Decoder Coprocessor (VCP)

The C6418 device has a high-performance embedded coprocessor [Viterbi-Decoder Coprocessor (VCP) that significantly speeds up channel-decoding operations on-chip. The VCP operating at CPU clock divided-by-4 can decode over 500 7.95-Kbps adaptive multi-rate (AMR) [$K = 9$, $R = 1/3$] voice channels. The VCP supports constraint lengths $K = 5, 6, 7, 8$, and 9 , rates $R = 1/2, 1/3$, and $1/4$, and flexible polynomials, while generating hard decisions or soft decisions. Communications between the VCP and the CPU are carried out through the EDMA controller.

For more detailed information on the VCP, see the *TMS320C64x DSP Viterbi-Decoder Coprocessor Reference Guide* (literature number SPRU533).

4.6 General-Purpose Input/Output (GPIO)

On the C6418 device the GPIO peripheral pins GP0[15:9] are muxed with the HPI peripheral pins HD[15:9], respectively. By default, the HPI peripheral pin functions are enabled [TOUT0/HPI_EN pin internally pulled low]. For more detailed information on device/peripheral configuration and the C6418 device pin muxing, see the Device Configurations section of this data sheet.

To use the GP0[15:0] software-configurable GPIO pins, the GPxEN bits in the GP Enable (GPEN) Register and the GPxDIR bits in the GP Direction (GPDIR) Register must be properly configured.

GPxEN = 1 GP[x] pin is enabled

GPxDIR = 0 GP[x] pin is an input

GPxDIR = 1 GP[x] pin is an output

where “x” represents one of the 15 through 0 GPIO pins

Figure 4–4 shows the GPIO enable bits in the GPEN register for the C6418 device. To use any of the GPx pins as general-purpose input/output functions, the corresponding GPxEN bit must be set to “1” (enabled). Default values are device-specific, so refer to Figure 4–4 for the C6418 default configuration.

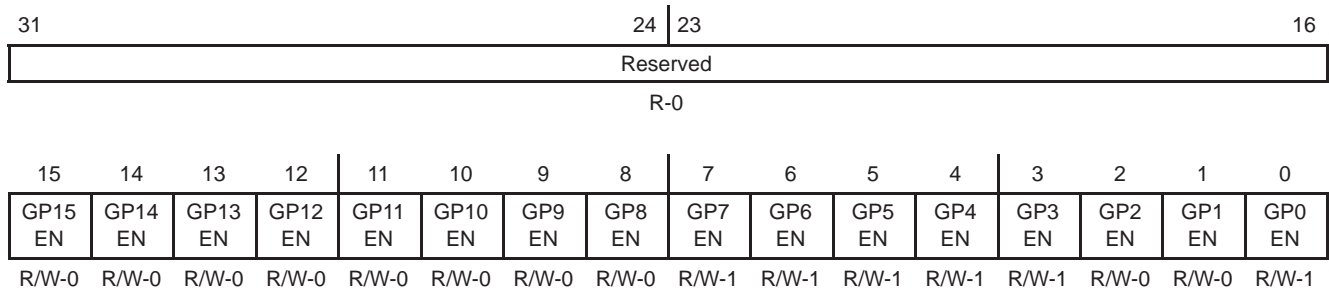

Legend: R/W = Readable/Writeable; -n = value after reset, -x = undefined value after reset

Figure 4–4. GPIO Enable Register (GPEN) [Hex Address: 01B0 0000]

Figure 4–5 shows the GPIO direction bits in the GPDIR register. This register determines if a given GPIO pin is an input or an output providing the corresponding GPxEN bit is enabled (set to “1”) in the GPEN register. By default, all the GPIO pins are configured as input pins.

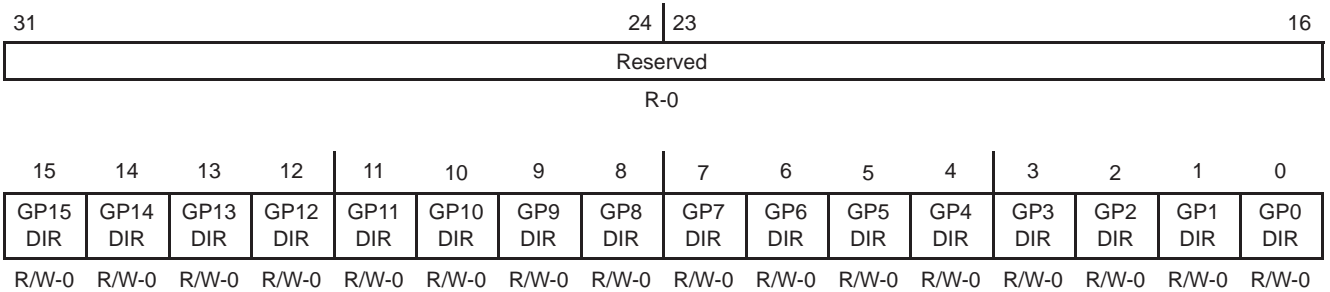

Legend: R/W = Readable/Writeable; -n = value after reset, -x = undefined value after reset

Figure 4–5. GPIO Direction Register (GPDIR) [Hex Address: 01B0 0004]

For more detailed information on general-purpose inputs/outputs (GPIOs), see the *TMS320C6000 DSP General-Purpose Input/Output (GPIO) Reference Guide* (literature number SPRU584).

4.7 Power-Down Modes Logic

Figure 4–6 shows the power-down mode logic on the C6418.

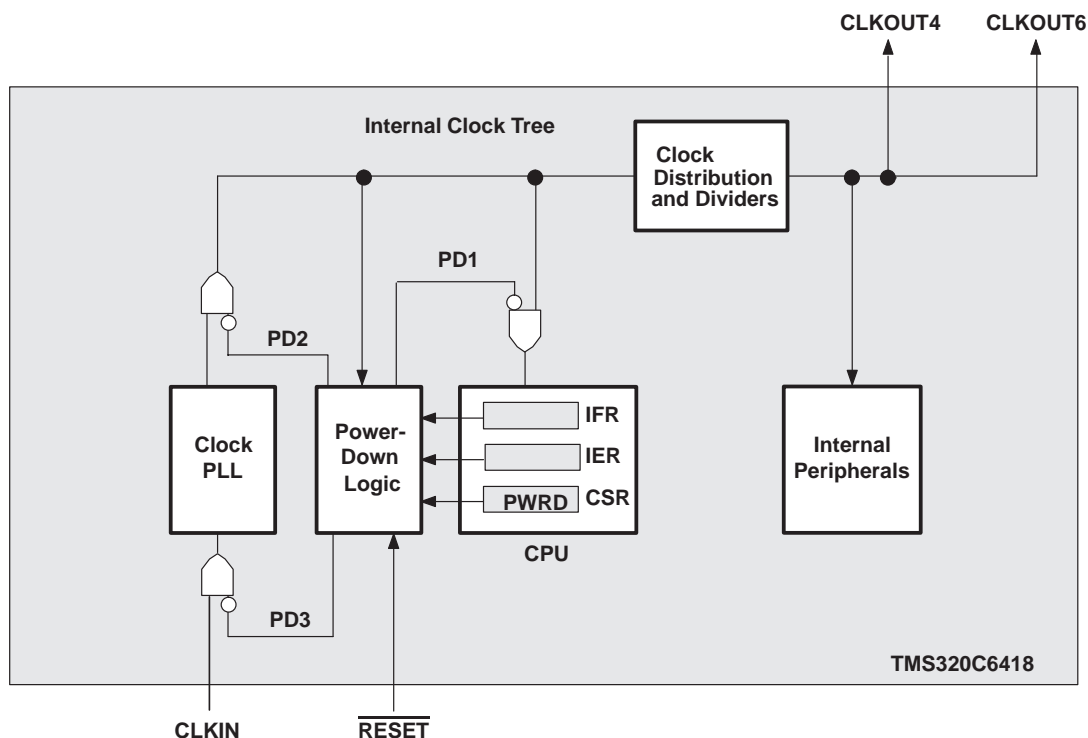

† External input clocks, with the exception of CLKIN, are *not* gated by the power-down mode logic.

Figure 4–6. Power-Down Mode Logic†

Note: to further save power, the PERCFG register can be used to disable unused peripherals. For more detailed information on disabling peripherals using the PERCFG register, see the *Device Configurations* section of this data sheet.

4.7.1 Triggering, Wake-up, and Effects

The power-down modes and their wake-up methods are programmed by setting the PWRD field (bits 15–10) of the control status register (CSR). The PWRD field of the CSR is shown in Figure 4–7 and described in Table 4–4. When writing to the CSR, all bits of the PWRD field should be set at the same time. Logic 0 should be used when writing to the reserved bit (bit 15) of the PWRD field. The CSR is discussed in detail in the *TMS320C6000 CPU and Instruction Set Reference Guide* (literature number SPRU189).

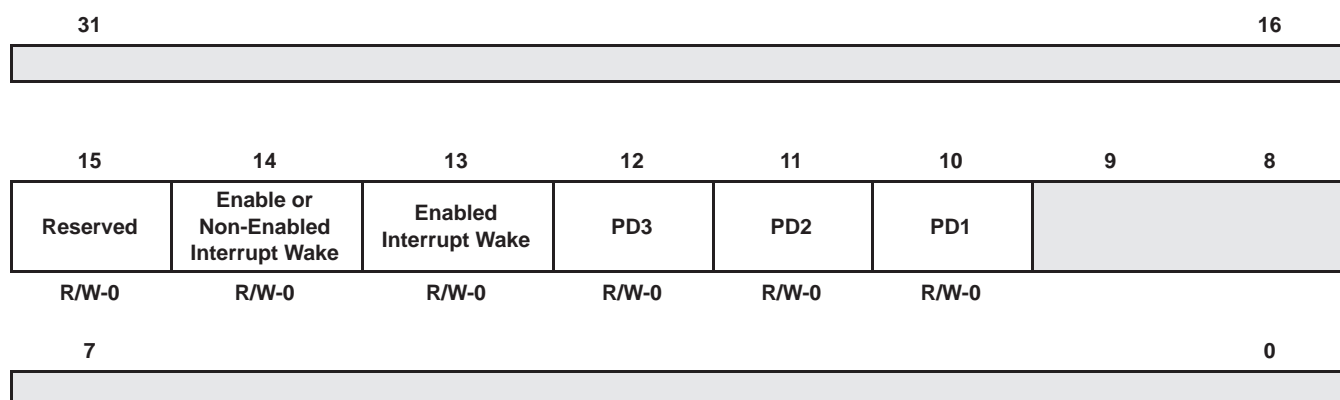

Legend: R/W-x = Read/write reset value

NOTE: The shadowed bits are not part of the power-down logic discussion and therefore are not covered here. For information on these other bit fields in the CSR register, see the *TMS320C6000 CPU and Instruction Set Reference Guide* (literature number SPRU189).

Figure 4–7. PWRD Field of the CSR Register

A delay of up to nine clock cycles may occur after the instruction that sets the PWRD bits in the CSR before the PD mode takes effect. As best practice, NOPs should be padded after the PWRD bits are set in the CSR to account for this delay.

If PD1 mode is terminated by a non-enabled interrupt, the program execution returns to the instruction where PD1 took effect. If PD1 mode is terminated by an enabled interrupt, the interrupt service routine will be executed first, then the program execution returns to the instruction where PD1 took effect. In the case with an enabled interrupt, the GIE bit in the CSR and the NMIE bit in the interrupt enable register (IER) must also be set in order for the interrupt service routine to execute; otherwise, execution returns to the instruction where PD1 took effect upon PD1 mode termination by an enabled interrupt.

PD2 and PD3 modes can only be aborted by device reset. Table 4–4 summarizes all the power-down modes.

Table 4–4. Characteristics of the Power-Down Modes

| PRWD FIELD (BITS 15–10) | POWER-DOWN MODE | WAKE-UP METHOD | EFFECT ON CHIP'S OPERATION |
|----------------------------|--------------------|---|--|
| 000000 | No power-down | — | — |
| 001001 | PD1 | Wake by an enabled interrupt | CPU halted (except for the interrupt logic) Power-down mode blocks the internal clock inputs at the boundary of the CPU, preventing most of the CPU's logic from switching. During PD1, EDMA transactions can proceed between peripherals and internal memory. |
| 010001 | PD1 | Wake by an enabled or non-enabled interrupt | |
| 011010 | PD2 [†] | Wake by a device reset | Output clock from PLL is halted, stopping the internal clock structure from switching and resulting in the entire chip being halted. All register and internal RAM contents are preserved. All functional I/O "freeze" in the last state when the PLL clock is turned off. |
| 011100 | PD3 [†] | Wake by a device reset | Input clock to the PLL stops generating clocks. All register and internal RAM contents are preserved. All functional I/O "freeze" in the last state when the PLL clock is turned off. Following reset, the PLL needs time to re-lock, just as it does following power-up. Wake-up from PD3 takes longer than wake-up from PD2 because the PLL needs to be re-locked, just as it does following power-up. |
| All others | Reserved | — | — |

[†] When entering PD2 and PD3, all functional I/O remains in the previous state. However, for peripherals which are asynchronous in nature or peripherals with an external clock source, output signals may transition in response to stimulus on the inputs. Under these conditions, peripherals will not operate according to specifications.

4.7.2 C64x Power-Down Mode with an Emulator

If user power-down modes are programmed, and an emulator is attached, the modes will be masked to allow the emulator access to the system. This condition prevails until the emulator is reset or the cable is removed from the header. If power measurements are to be performed when in a power-down mode, the emulator cable should be removed.

When the DSP is in power-down mode PD2 or PD3, emulation logic will force any emulation execution command (such as Step or Run) to spin in IDLE. For this reason, PC writes (such as loading code) will fail. A DSP reset will be required to get the DSP out of PD2/PD3.

4.8 Power-Supply Sequencing

TI DSPs do not require specific power sequencing between the core supply and the I/O supply. However, systems should be designed to ensure that neither supply is powered up for extended periods of time (>1 second) if the other supply is below the proper operating voltage.

4.8.1 Power-Supply Design Considerations

A dual-power supply with simultaneous sequencing can be used to eliminate the delay between core and I/O power up. A Schottky diode can also be used to tie the core rail to the I/O rail (see Figure 4–8).

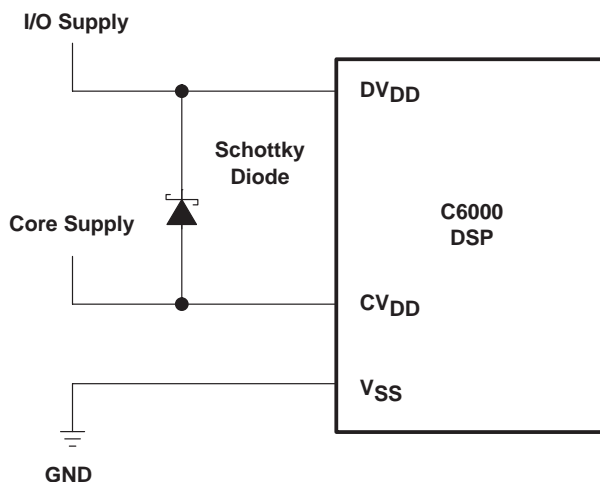

Figure 4–8. Schottky Diode Diagram

Core and I/O supply voltage regulators should be located close to the DSP (or DSP array) to minimize inductance and resistance in the power delivery path. Additionally, when designing for high-performance applications utilizing the C6000™ platform of DSPs, the PC board should include separate power planes for core, I/O, and ground, all bypassed with high-quality low-ESL/ESR capacitors.

TI DSPs do not require specific power sequencing between the core supply and the I/O supply. However, systems should be designed to ensure that neither supply is powered up for extended periods of time if the other supply is below the proper operating voltage.

4.9 Power-Supply Decoupling

In order to properly decouple the supply planes from system noise, place as many capacitors (caps) as possible close to the DSP. Assuming 0603 caps, the user should be able to fit a total of 60 caps, 30 for the core supply and 30 for the I/O supply. These caps need to be close to the DSP power pins, no more than 1.25 cm maximum distance to be effective. Physically smaller caps, such as 0402, are better because of their lower parasitic inductance. Proper capacitance values are also important. Small bypass caps (near 560 pF) should be closest to the power pins. Medium bypass caps (220 nF or as large as can be obtained in a small package) should be next closest. TI recommends no less than 8 small and 8 medium caps per supply (32 total) be placed immediately next to the BGA vias, using the “interior” BGA space and at least the corners of the “exterior”.

Eight larger caps (4 for each supply) can be placed further away for bulk decoupling. Large bulk caps (on the order of 100 μ F) should be furthest away (but still as close as possible). No less than 4 large caps per supply (8 total) should be placed outside of the BGA.

Any cap selection needs to be evaluated from a yield/manufacturing point-of-view. As with the selection of any component, verification of capacitor availability over the product's production lifetime should be considered.

4.10 Peripheral Power-Down Operation

The C6418 device can be powered down in two ways:

- Power-down due to software configuration – relates to the default state of the peripheral configuration bits in the PERCFG register.
- Power-down during run-time via software configuration

On the C6418 device, the HPI, McASP1, and GP0 peripherals pin muxing is controlled (selected) at the pin level during chip reset (e.g., $\overline{\text{HPI_EN}}$ and HD5 pins). If McASP1 pin muxing is selected, then the McASP1 peripheral configuration register bit must be configured properly to enable the McASP1 peripheral.

The McASP1, McASP0, I2C1, and I2C0 peripheral functions are selected via the peripheral configuration (PERCFG) register bits.

For more detailed information on the peripheral configuration pins and the PERCFG register bits, see the *Device Configurations* section of this document.

4.11 IEEE 1149.1 JTAG Compatibility Statement

The TMS320C6418 DSP requires that both $\overline{\text{TRST}}$ and $\overline{\text{RESET}}$ be asserted upon power up to be properly initialized. While $\overline{\text{RESET}}$ initializes the DSP core, $\overline{\text{TRST}}$ initializes the DSP's emulation logic. Both resets are required for proper operation.

Note: $\overline{\text{TRST}}$ is synchronous and *must* be clocked by TCLK; otherwise, BSCAN may not respond as expected after $\overline{\text{TRST}}$ is asserted.

While both $\overline{\text{TRST}}$ and $\overline{\text{RESET}}$ need to be asserted upon power up, only $\overline{\text{RESET}}$ needs to be released for the DSP to boot properly. $\overline{\text{TRST}}$ may be asserted indefinitely for normal operation, keeping the JTAG port interface and DSP's emulation logic in the reset state. $\overline{\text{TRST}}$ only needs to be released when it is necessary to use a JTAG controller to debug the DSP or exercise the DSP's boundary scan functionality. $\overline{\text{RESET}}$ must be released in order for boundary-scan JTAG to read the variant field of IDCODE correctly. Other boundary-scan instructions work correctly independent of current state of $\overline{\text{RESET}}$.

The TMS320C6418 DSP includes an internal pulldown (IPD) on the $\overline{\text{TRST}}$ pin to ensure that $\overline{\text{TRST}}$ will always be asserted upon power up and the DSP's internal emulation logic will always be properly initialized when this pin is not routed out. JTAG controllers from Texas Instruments actively drive $\overline{\text{TRST}}$ high. However, some third-party JTAG controllers may not drive $\overline{\text{TRST}}$ high but expect the use of an external pullup resistor on $\overline{\text{TRST}}$. When using this type of JTAG controller, assert $\overline{\text{TRST}}$ to initialize the DSP after powerup and externally drive $\overline{\text{TRST}}$ high before attempting any emulation or boundary scan operations.

Following the release of $\overline{\text{RESET}}$, the low-to-high transition of $\overline{\text{TRST}}$ must occur to latch the state of EMU1 and EMU0. The EMU[1:0] pins configure the device for either Boundary Scan mode or Normal/Emulation mode. For more detailed information, see the terminal functions section of this data sheet.

Note: The DESIGN_WARNING section of the TMS320C6418 BSDL file contains information and constraints regarding proper device operation while in Boundary Scan Mode.

For more detailed information on the C6418 JTAG emulation, see the *TMS320C6000 DSP Designing for JTAG Emulation Reference Guide* (literature number SPRU641).

4.12 EMIF Device Speed

The rated EMIF speed of these devices only applies to the SDRAM interface when in a system that meets the following requirements:

- 1 chip-enable (CE) space (maximum of 2 chips) of SDRAM connected to EMIF
- up to 1 CE space of buffers connected to EMIF
- EMIF trace lengths between 1 and 3 inches
- 166-MHz SDRAM for 133-MHz operation
- 143-MHz SDRAM for 100-MHz operation

Other configurations may be possible, but timing analysis must be done to verify all AC timings are met. Verification of AC timings is mandatory when using configurations other than those specified above. TI recommends utilizing I/O buffer information specification (IBIS) to analyze all AC timings.

To properly use IBIS models to attain accurate timing analysis for a given system, see the *Using IBIS Models for Timing Analysis* application report (literature number SPRA839).

To maintain signal integrity, serial termination resistors should be inserted into all EMIF output signal lines (see the Terminal Functions table for the EMIF output signals).

For more detailed information on the C6418 EMIF peripheral, see the *TMS320C6000 DSP External Memory Interface (EMIF) Reference Guide* (literature number SPRU266).

4.13 Bootmode

The C6418 device resets using the active-low signal $\overline{\text{RESET}}$. While $\overline{\text{RESET}}$ is low, the device is held in reset and is initialized to the prescribed reset state. Refer to reset timing for reset timing characteristics and states of device pins during reset. The release of $\overline{\text{RESET}}$ starts the processor running with the prescribed device configuration and boot mode.

The C6418 has three types of boot modes:

- Host boot

If host boot is selected, upon release of $\overline{\text{RESET}}$, the CPU is internally “stalled” while the remainder of the device is released. During this period, an external host can initialize the CPU’s memory space as necessary through the host interface, including internal configuration registers, such as those that control the EMIF or other peripherals. For the C6418 device, the HPI peripheral is used for host boot providing the TOUT0/HPI_EN pin is low, enabling the HPI peripheral [default]. Once the host is finished with all necessary initialization, it must set the DSPINT bit in the HPIC register to complete the boot process. This transition causes the boot configuration logic to bring the CPU out of the “stalled” state. The CPU then begins execution from address 0. The DSPINT condition is not latched by the CPU, because it occurs while the CPU is still internally “stalled”. Also, DSPINT brings the CPU out of the “stalled” state only if the host boot process is selected. All memory may be written to and read by the host. This allows for the host to verify what it sends to the DSP if required. After the CPU is out of the “stalled” state, the CPU needs to clear the DSPINT, otherwise, no more DSPINTs can be received.

- EMIF boot (using default ROM timings)

Upon the release of $\overline{\text{RESET}}$, the 1K-Byte ROM code located in the beginning of $\overline{\text{CE1}}$ is copied to address 0 by the EDMA using the default ROM timings, while the CPU is internally “stalled”. The data should be stored in the endian format that the system is using. In this case, the EMIF automatically assembles consecutive 8-bit bytes to form the 32-bit instruction words to be copied. The transfer is automatically done by the EDMA as a single-frame block transfer from the ROM to address 0. After completion of the block transfer, the CPU is released from the “stalled” state and starts running from address 0.

- No boot

With no boot, the CPU begins direct execution from the memory located at address 0. Note: operation is undefined if invalid code is located at address 0.

4.14 Reset

A hardware reset ($\overline{\text{RESET}}$) is required to place the DSP into a known good state out of power-up. The $\overline{\text{RESET}}$ signal can be asserted (pulled low) prior to ramping the core and I/O voltages or after the core and I/O voltages have reached their proper operating conditions. As a best practice, reset should be held low during power-up. Prior to deasserting $\overline{\text{RESET}}$ (low-to-high transition), the core and I/O voltages should be at their proper operating conditions and CLKIN should also be running at the correct frequency.

5 Device Electrical Specifications

5.1 Absolute Maximum Ratings Over Operating Case Temperature Range (Unless Otherwise Noted)[†]

| | | | |
|---|---------------------------------|-------|------------------|
| Supply voltage ranges: | CV_{DD} (see Note 1) | | - 0.3 V to 1.8 V |
| | DV_{DD} (see Note 1) | | -0.3 V to 4 V |
| Input voltage range: | V_I | | -0.3 V to 4 V |
| Output voltage range: | V_O | | -0.3 V to 4 V |
| Operating case temperature range, T_C : (default) [GTS and ZTS] | | | 0°C to 90°C |
| | (A version) [GTSA and ZTSA] | | -40°C to 105°C |
| Storage temperature range, T_{stg} | | | -65°C to 150°C |
| Package Temperature Cycling: | Temperature Range | | -40°C to 125°C |
| | Number of Cycles (GTS and GTSA) | | 1000 |
| | Number of Cycles (ZTS and ZTSA) | | 500 |

[†] Stresses beyond those listed under “absolute maximum ratings” may cause permanent damage to the device. These are stress ratings only, and functional operation of the device at these or any other conditions beyond those indicated under “recommended operating conditions” is not implied. Exposure to absolute-maximum-rated conditions for extended periods may affect device reliability.

NOTE 1: All voltage values are with respect to V_{SS} .

5.2 Recommended Operating Conditions

| | | MIN | NOM | MAX | UNIT |
|-----------|---|-------------------|-----|------------------|------|
| CV_{DD} | Supply voltage, Core (-500 device) [‡] | 1.14 | 1.2 | 1.26 | V |
| | Supply voltage, Core (-600 device) [‡] | 1.36 | 1.4 | 1.44 | V |
| DV_{DD} | Supply voltage, I/O | 3.14 | 3.3 | 3.46 | V |
| V_{SS} | Supply ground | 0 | 0 | 0 | V |
| V_{IH} | High-level input voltage | 2 | | | V |
| V_{IL} | Low-level input voltage | | | 0.8 | V |
| V_{OS} | Maximum voltage during overshoot | | | 4.3 [§] | V |
| V_{us} | Minimum voltage during undershoot | -1.0 [§] | | | V |
| T_C | Operating case temperature | | | | |
| | Commercial temperature device (GTS and ZTS) | 0 | | 90 | °C |
| | Extended temperature device (GTSA and ZTSA) | -40 | | 105 | °C |

[‡] Future variants of the C64x DSPs may operate at voltages ranging from 0.9 V to 1.4 V to provide a range of system power/performance options. TI highly recommends that users design-in a supply that can handle multiple voltages within this range (i.e., 1.2 V, 1.25 V, 1.3 V, 1.35 V, 1.4 V with $\pm 3\%$ tolerances) by implementing simple board changes such as reference resistor values or input pin configuration modifications. Examples of such supplies include the PT4660, PT5500, PT5520, PT6440, and PT6930 series from Power Trends, a subsidiary of Texas Instruments. Not incorporating a flexible supply may limit the system’s ability to easily adapt to future versions of C64x devices.

[§] The absolute maximum ratings should *not* be exceeded for more than 30% of the cycle period.

5.3 Electrical Characteristics Over Recommended Ranges of Supply Voltage and Operating Case Temperature (Unless Otherwise Noted)

| PARAMETER | | TEST CONDITIONS† | MIN | TYP | MAX | UNIT |
|------------------|---------------------------|---|------|------|-----|------|
| V _{OH} | High-level output voltage | DV _{DD} = MIN, I _{OH} = MAX | 2.4 | | | V |
| V _{OL} | Low-level output voltage | DV _{DD} = MIN, I _{OL} = MAX | | | 0.4 | V |
| I _I | Input current | V _I = V _{SS} to DV _{DD} no opposing internal resistor | | | ±10 | µA |
| | | V _I = V _{SS} to DV _{DD} opposing internal pullup resistor‡ | 50 | 100 | 150 | µA |
| | | V _I = V _{SS} to DV _{DD} opposing internal pulldown resistor‡ | -150 | -100 | -50 | µA |
| I _{OH} | High-level output current | EMIF, CLKOUT4, CLKOUT6, EMUx | | | -16 | mA |
| | | Timer, TDO, GPIO, McBSP, HPI | | | -8 | mA |
| I _{OL} | Low-level output current | EMIF, CLKOUT4, CLKOUT6, EMUx | | | 16 | mA |
| | | Timer, TDO, GPIO, McBSP, HPI | | | 8 | mA |
| | | SCL1, SDA1, SCL0, and SDA0 | | | 3 | mA |
| I _{OZ} | Off-state output current | V _O = DV _{DD} or 0 V | | | ±10 | µA |
| I _{CDD} | Core supply current§ | CV _{DD} = 1.4 V, CPU clock = 600 MHz | | 828 | | mA |
| | | CV _{DD} = 1.2 V, CPU clock = 500 MHz | | 568 | | mA |
| I _{DDD} | I/O supply current§ | DV _{DD} = 3.3 V, CPU clock = 600 MHz | | 167 | | mA |
| | | DV _{DD} = 3.3 V, CPU clock = 500 MHz | | 140 | | mA |
| C _i | Input capacitance | | | | 10 | pF |
| C _o | Output capacitance | | | | 10 | pF |

† For test conditions shown as MIN, MAX, or NOM, use the appropriate value specified in the recommended operating conditions table.

‡ Applies only to pins with an internal pullup (IPU) or pulldown (IPD) resistor.

§ Measured with average activity (50% high/50% low power) at 25°C case temperature and 133-MHz EMIF for -600 speed and 100-MHz EMIF for -500 speed. This model represents a device performing high-DSP-activity operations 50% of the time, and the remainder performing low-DSP-activity operations. The high/low-DSP-activity models are defined as follows:

High-DSP-Activity Model:

CPU: 8 instructions/cycle with 2 LDDW instructions [L1 Data Memory: 128 bits/cycle via LDDW instructions;

L1 Program Memory: 256 bits/cycle; L2/EMIF EDMA: 50% writes, 50% reads to/from SDRAM (50% bit-switching)]

McBSP: 2 channels at E1 rate

Timers: 2 timers at maximum rate

Low-DSP-Activity Model:

CPU: 2 instructions/cycle with 1 LDH instruction [L1 Data Memory: 16 bits/cycle; L1 Program Memory: 256 bits per 4 cycles;

L2/EMIF EDMA: None]

McBSP: 2 channels at E1 rate

Timers: 2 timers at maximum rate

The actual current draw is highly application-dependent. For more details on core and I/O activity, refer to the *TMS320C6418 Power Consumption Summary* application report (literature number SPRAA60).

5.4 Recommended Clock and Control Signal Transition Behavior

All clocks and control signals **must** transition between V_{IH} and V_{IL} (or between V_{IL} and V_{IH}) in a monotonic manner.

6 Parameter Information

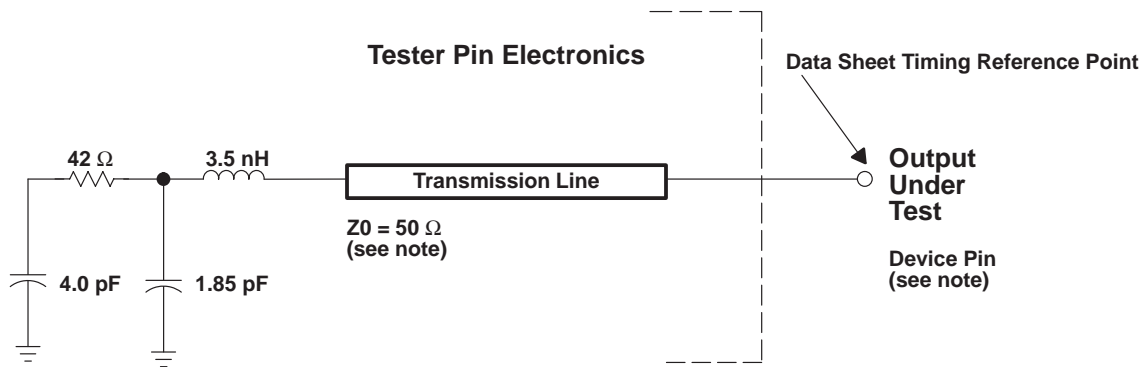

NOTE: The data sheet provides timing at the device pin. For output timing analysis, the tester pin electronics and its transmission line effects must be taken into account. A transmission line with a delay of 2 ns or longer can be used to produce the desired transmission line effect. The transmission line is intended as a load only. It is not necessary to add or subtract the transmission line delay (2 ns or longer) from the data sheet timings.

Input requirements in this data sheet are tested with an input slew rate of < 4 Volts per nanosecond (4 V/ns) at the device pin.

Figure 6–1. Test Load Circuit for AC Timing Measurements

The load capacitance value stated is only for characterization and measurement of AC timing signals. This load capacitance value does not indicate the maximum load the device is capable of driving.

6.1 Signal Transition Levels

All input and output timing parameters are referenced to 1.5 V for both “0” and “1” logic levels.

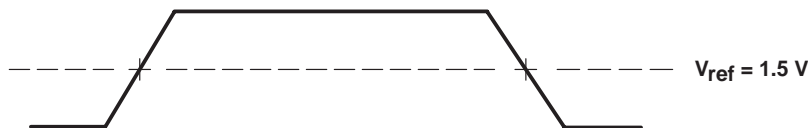

Figure 6–2. Input and Output Voltage Reference Levels for AC Timing Measurements

All rise and fall transition timing parameters are referenced to $V_{IH\ MAX}$ and $V_{IH\ MIN}$ for input clocks, $V_{OL\ MAX}$ and $V_{OH\ MIN}$ for output clocks.

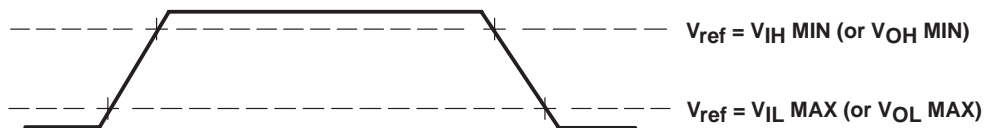

Figure 6–3. Rise and Fall Transition Time Voltage Reference Levels

6.2 Signal Transition Rates

All timings are tested with an input edge rate of 4 Volts per nanosecond (4 V/ns).

PARAMETER MEASUREMENT INFORMATION (CONTINUED)

6.3 AC transient rise/fall time specifications

Figure 6–4 and Figure 6–5 show the AC transient specifications for Rise and Fall Time. For device-specific information on these values, refer to the Recommended Operating Conditions section of this Data Sheet.

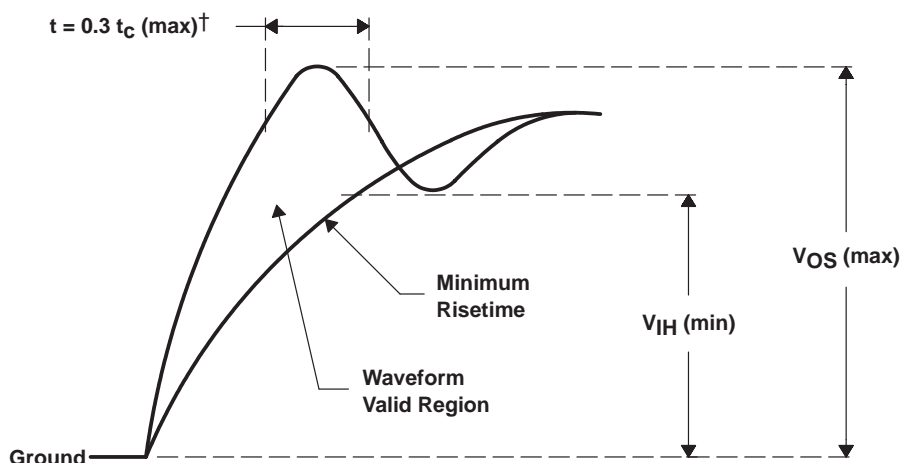
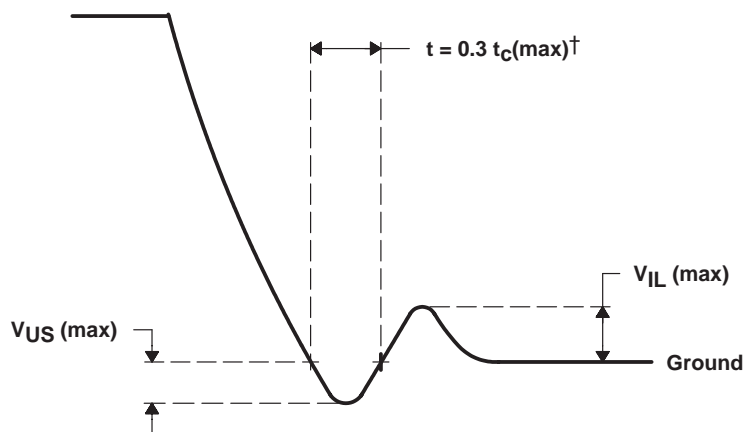

Figure 6–4. AC Transient Specification Rise Time

† t_C = the peripheral cycle time.



† t_C = the peripheral cycle time.

Figure 6–5. AC Transient Specification Fall Time

6.4 Timing Parameters and Board Routing Analysis

The timing parameter values specified in this data sheet do *not* include delays by board routings. As a good board design practice, such delays must *always* be taken into account. Timing values may be adjusted by increasing/decreasing such delays. TI recommends utilizing the available I/O buffer information specification (IBIS) models to analyze the timing characteristics correctly. To properly use IBIS models to attain accurate timing analysis for a given system, see the *Using IBIS Models for Timing Analysis* application report (literature number SPRA839). If needed, external logic hardware such as buffers may be used to compensate any timing differences.

For inputs, timing is most impacted by the round-trip propagation delay from the DSP to the external device and from the external device to the DSP. This round-trip delay tends to negatively impact the input setup time margin, but also tends to improve the input hold time margins (see Table 6–1 and Figure 6–6).

Figure 6–6 represents a general transfer between the DSP and an external device. The figure also represents board route delays and how they are perceived by the DSP and the external device.

Table 6–1. Board-Level Timing Example (see Figure 6–6)

| NO. | DESCRIPTION |
|-----|--|
| 1 | Clock route delay |
| 2 | Minimum DSP hold time |
| 3 | Minimum DSP setup time |
| 4 | External device hold time requirement |
| 5 | External device setup time requirement |
| 6 | Control signal route delay |
| 7 | External device hold time |
| 8 | External device access time |
| 9 | DSP hold time requirement |
| 10 | DSP setup time requirement |
| 11 | Data route delay |

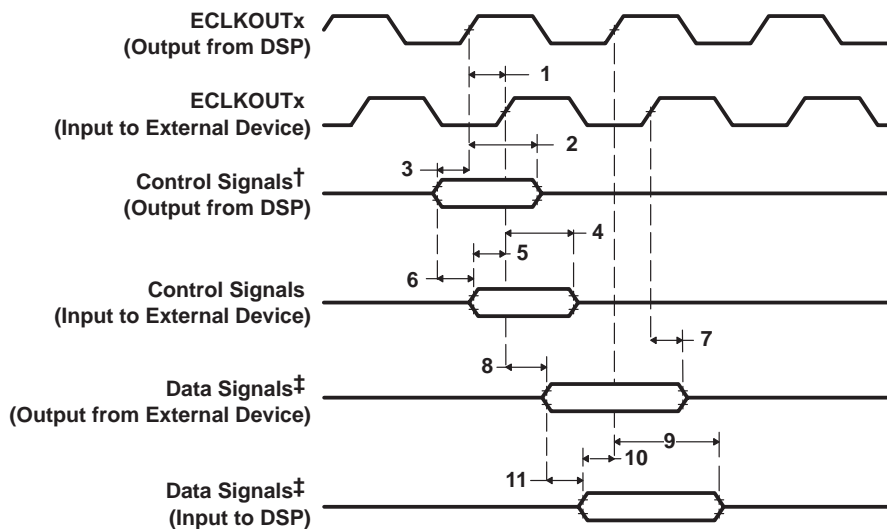

† Control signals include data for Writes.
 ‡ Data signals are generated during Reads from an external device.

Figure 6–6. Board-Level Input/Output Timings

7 Peripheral Electrical Specifications

7.1 Input and Output Clocks

Table 7–1. Timing Requirements for External Crystal Oscillator Input (OSCIN and OSCOUT)

| NO. | | -500 -600 | | UNIT |
|-----|--------------------------------------|--------------|-----|------|
| | | MIN | MAX | |
| 1 | f_{OSC} Input oscillator frequency | 12 | 30 | MHz |

† The PLL multiplier factors (x5, x6, x7, x8, x9, x10, x11, x12, x16, x18, x19, x20, x21, x24) further limit the MIN and MAX values for CLKIN and OSCIN. For more details on these limitations, see Table 4–1 of the *Clock PLL and Oscillator* section of this data sheet.

Table 7–2. Timing Requirements for CLKIN†‡§ (see Figure 7–1)

| NO. | | -500 -600 | | | | UNIT |
|-----|---|---------------|------|-------------|------|------|
| | | PLL MULT MODE | | x1 (BYPASS) | | |
| | | MIN | MAX | MIN | MAX | |
| 1 | $t_c(\text{CLKIN})$ Cycle time, CLKIN | 10† | 83.3 | 10† | 83.3 | ns |
| 2 | $t_w(\text{CLKINH})$ Pulse duration, CLKIN high | 0.45C | | 0.45C | | ns |
| 3 | $t_w(\text{CLKINL})$ Pulse duration, CLKIN low | 0.45C | | 0.45C | | ns |
| 4 | $t_t(\text{CLKIN})$ Transition time, CLKIN | 5 | | 1 | | ns |
| 5 | $t_j(\text{CLKIN})$ Period jitter, CLKIN | 0.02C | | 0.02C | | ns |

† The PLL multiplier factors (x5, x6, x7, x8, x9, x10, x11, x12, x16, x18, x19, x20, x21, x24) further limit the MIN and MAX values for CLKIN and OSCIN. For more details on these limitations, see Table 4–1 of the *Clock PLL and Oscillator* section of this data sheet.

‡ The reference points for the rise and fall transitions are measured at $V_{IL\ MAX}$ and $V_{IH\ MIN}$.

§ C = CLKIN cycle time in ns. For example, when CLKIN frequency is 50 MHz, use C = 20 ns.

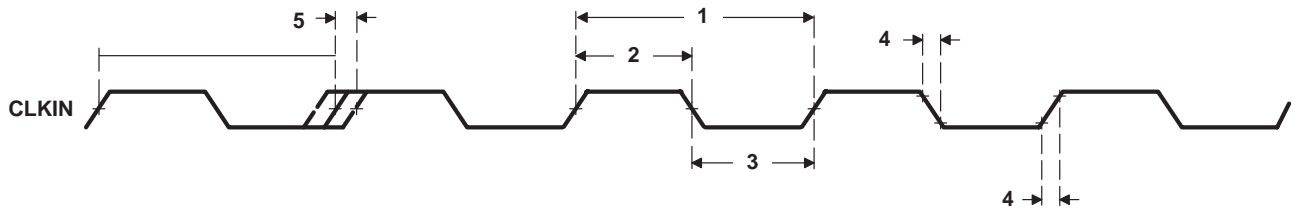

Figure 7–1. CLKIN Timing

Table 7-3. Switching Characteristics Over Recommended Operating Conditions for CLKOUT4†‡§
(see Figure 7-2)

| NO. | PARAMETER | -500 -600 | | UNIT |
|-----|--|--------------|------------|------|
| | | MIN | MAX | |
| 1 | $t_c(\text{CKO4})$ Cycle time, CLKOUT4 | $4P - 0.7$ | $4P + 0.7$ | ns |
| 2 | $t_w(\text{CKO4H})$ Pulse duration, CLKOUT4 high | $2P - 0.7$ | $2P + 0.7$ | ns |
| 3 | $t_w(\text{CKO4L})$ Pulse duration, CLKOUT4 low | $2P - 0.7$ | $2P + 0.7$ | ns |
| 4 | $t_t(\text{CKO4})$ Transition time, CLKOUT4 | | 1 | ns |

† The reference points for the rise and fall transitions are measured at $V_{OL \text{ MAX}}$ and $V_{OH \text{ MIN}}$.

‡ PH is the high period of CLKIN in ns and PL is the low period of CLKIN in ns.

§ P = 1/CPU clock frequency in nanoseconds (ns)

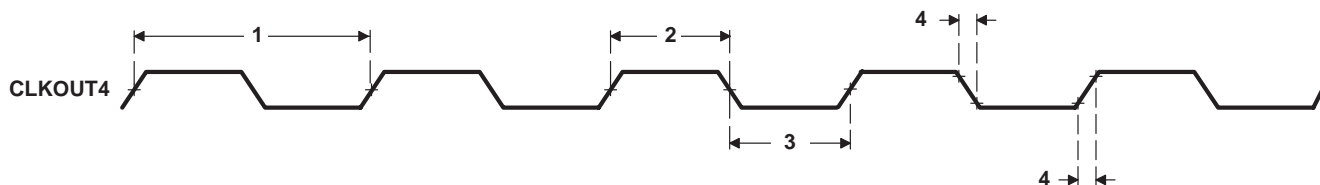

Figure 7-2. CLKOUT4 Timing

Table 7-4. Switching Characteristics Over Recommended Operating Conditions for CLKOUT6†‡§
(see Figure 7-3)

| NO. | PARAMETER | -500 -600 | | UNIT |
|-----|--|--------------|------------|------|
| | | MIN | MAX | |
| 1 | $t_c(\text{CKO6})$ Cycle time, CLKOUT6 | $6P - 0.7$ | $6P + 0.7$ | ns |
| 2 | $t_w(\text{CKO6H})$ Pulse duration, CLKOUT6 high | $3P - 0.7$ | $3P + 0.7$ | ns |
| 3 | $t_w(\text{CKO6L})$ Pulse duration, CLKOUT6 low | $3P - 0.7$ | $3P + 0.7$ | ns |
| 4 | $t_t(\text{CKO6})$ Transition time, CLKOUT6 | | 1 | ns |

† The reference points for the rise and fall transitions are measured at $V_{OL \text{ MAX}}$ and $V_{OH \text{ MIN}}$.

‡ PH is the high period of CLKIN in ns and PL is the low period of CLKIN in ns.

§ P = 1/CPU clock frequency in nanoseconds (ns)

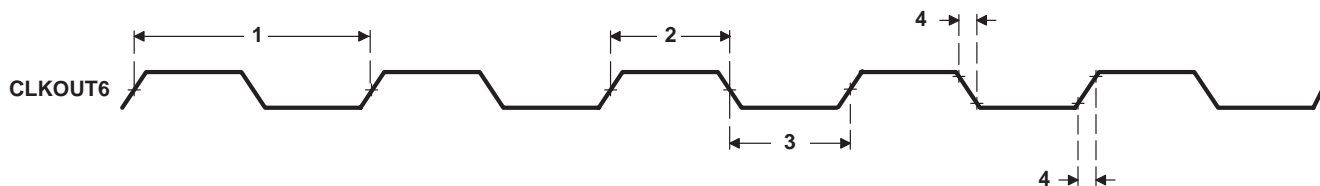

Figure 7-3. CLKOUT6 Timing

Table 7–5. Timing Requirements for AECLKIN for EMIFAT†§ (see Figure 7–4)

| NO. | | -500 -600 | | UNIT |
|-----|---|--------------|-------|------|
| | | MIN | MAX | |
| 1 | $t_c(\text{EKI})$ Cycle time, AECLKIN | 6† | 16P | ns |
| 2 | $t_w(\text{EKIH})$ Pulse duration, AECLKIN high | 2.7 | | ns |
| 3 | $t_w(\text{EKIL})$ Pulse duration, AECLKIN low | 2.7 | | ns |
| 4 | $t_t(\text{EKI})$ Transition time, AECLKIN | | 3 | ns |
| 5 | $t_J(\text{EKI})$ Period jitter, AECLKIN | | 0.02E | ns |

† P = 1/CPU clock frequency in ns. For example, when running parts at 600 MHz, use P = 1.67 ns.

‡ The reference points for the rise and fall transitions are measured at $V_{IL \text{ MAX}}$ and $V_{IH \text{ MIN}}$.

§ E = the EMIF input clock (AECLKIN, CPU/4 clock, or CPU/6 clock) period in ns.

¶ Minimum AECLKIN cycle times *must* be met, even when AECLKIN is generated by an internal clock source. Minimum AECLKIN times are based on internal logic speed; the maximum useable speed of the EMIF may be lower due to AC timing requirements. 133-MHz and 100-MHz operations are achievable if the requirements of the EMIF Device Speed section are met.

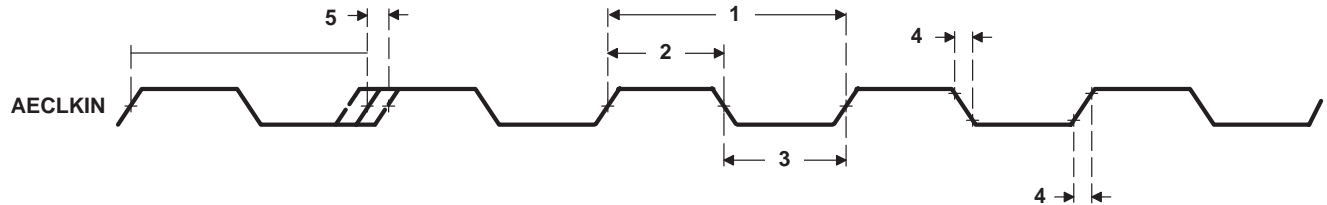

Figure 7–4. AECLKIN Timing for EMIFA

Table 7–6. Switching Characteristics Over Recommended Operating Conditions for AECLKOUT1 for the EMIFA Module§#|| (see Figure 7–5)

| NO. | PARAMETER | -500 -600 | | UNIT |
|-----|---|--------------|----------|------|
| | | MIN | MAX | |
| 1 | $t_c(\text{EKO1})$ Cycle time, AECLKOUT1 | E - 0.7 | E + 0.7 | ns |
| 2 | $t_w(\text{EKO1H})$ Pulse duration, AECLKOUT1 high | EH - 0.7 | EH + 0.7 | ns |
| 3 | $t_w(\text{EKO1L})$ Pulse duration, AECLKOUT1 low | EL - 0.7 | EL + 0.7 | ns |
| 4 | $t_t(\text{EKO1})$ Transition time, AECLKOUT1 | | 1 | ns |
| 5 | $t_d(\text{EKIH-EKO1H})$ Delay time, AECLKIN high to AECLKOUT1 high | 1 | 8 | ns |
| 6 | $t_d(\text{EKIL-EKO1L})$ Delay time, AECLKIN low to AECLKOUT1 low | 1 | 8 | ns |

§ E = the EMIF input clock (AECLKIN, CPU/4 clock, or CPU/6 clock) period in ns.

The reference points for the rise and fall transitions are measured at $V_{OL \text{ MAX}}$ and $V_{OH \text{ MIN}}$.

|| EH is the high period of E (EMIF input clock period) in ns and EL is the low period of E (EMIF input clock period) in ns for EMIFA.

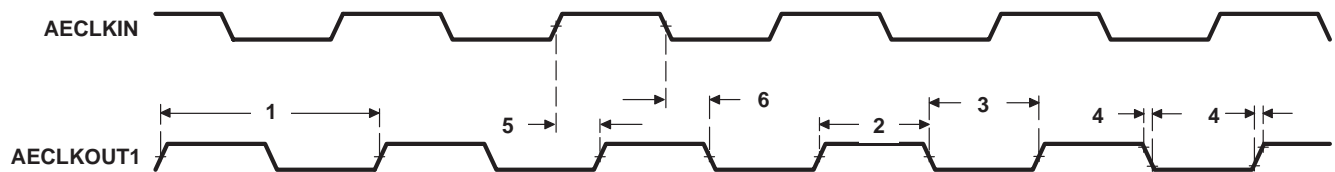

Figure 7–5. AECLKOUT1 Timing for the EMIFA Module

Table 7–7. Switching Characteristics Over Recommended Operating Conditions for AECLKOUT2 for the EMIFA Module†‡ (see Figure 7–6)

| NO. | PARAMETER | -500 -600 | | UNIT |
|-----|---|---------------|---------------|------|
| | | MIN | MAX | |
| 1 | $t_{c}(EKO2)$ Cycle time, AECLKOUT2 | $NE - 0.7$ | $NE + 0.7$ | ns |
| 2 | $t_{w}(EKO2H)$ Pulse duration, AECLKOUT2 high | $0.5NE - 0.7$ | $0.5NE + 0.7$ | ns |
| 3 | $t_{w}(EKO2L)$ Pulse duration, AECLKOUT2 low | $0.5NE - 0.7$ | $0.5NE + 0.7$ | ns |
| 4 | $t_{t}(EKO2)$ Transition time, AECLKOUT2 | | 1 | ns |
| 5 | $t_{d}(EKIH-EKO2H)$ Delay time, ECLKIN high to AECLKOUT2 high | 1 | 8 | ns |
| 6 | $t_{d}(EKIL-EKO2L)$ Delay time, ECLKIN low to AECLKOUT2 low | 1 | 8 | ns |

† The reference points for the rise and fall transitions are measured at $V_{OL\ MAX}$ and $V_{OH\ MIN}$.

‡ E = the EMIF input clock (AECLKIN, CPU/4 clock, or CPU/6 clock) period in ns for EMIFA.

N = the EMIF input clock divider; N = 1, 2, or 4.

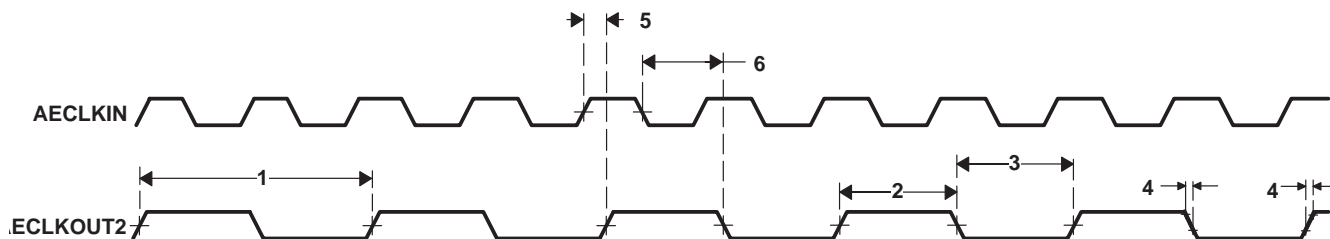

Figure 7–6. AECLKOUT2 Timing for the EMIFA Module

7.2 Asynchronous Memory Timing

Table 7–8. Timing Requirements for Asynchronous Memory Cycles for EMIFA Module†‡
(see Figure 7–7 and Figure 7–8)

| NO. | | -500 -600 | | UNIT |
|-----|---|--------------|-----|------|
| | | MIN | MAX | |
| 3 | $t_{su}(EDV-AREH)$ Setup time, AEDx valid before \overline{AARE} high | 6.5 | | ns |
| 4 | $t_h(AREH-EDV)$ Hold time, AEDx valid after \overline{AARE} high | 1 | | ns |
| 6 | $t_{su}(ARDY-EKO1H)$ Setup time, AARDY valid before AECLKOUTx high | 3 | | ns |
| 7 | $t_h(EKO1H-ARDY)$ Hold time, AARDY valid after AECLKOUTx high | 3 | | ns |

† To ensure data setup time, simply program the strobe width wide enough. AARDY is internally synchronized. The AARDY signal is *only* recognized two cycles before the end of the programmed strobe time and while AARDY is low, the strobe time is extended cycle-by-cycle. When AARDY is recognized low, the end of the strobe time is two cycles after AARDY is recognized high. To use AARDY as an asynchronous input, the pulse width of the AARDY signal should be wide enough (e.g., pulse width = 2E) to ensure setup and hold time is met.

‡ RS = Read setup, RST = Read strobe, RH = Read hold, WS = Write setup, WST = Write strobe, WH = Write hold. These parameters are programmed via the EMIF CE space control registers.

Table 7–9. Switching Characteristics Over Recommended Operating Conditions for Asynchronous Memory Cycles for EMIFA Module†§¶ (see Figure 7–7 and Figure 7–8)

| NO. | PARAMETER | -500 -600 | | UNIT |
|-----|---|--------------|-----|------|
| | | MIN | MAX | |
| 1 | $t_{osu}(SELV-AREL)$ Output setup time, select signals valid to \overline{AARE} low | RS * E - 1.5 | | ns |
| 2 | $t_{oh}(AREH-SELIV)$ Output hold time, \overline{AARE} high to select signals invalid | RH * E - 1.9 | | ns |
| 5 | $t_d(EKO1H-AREV)$ Delay time, AECLKOUTx high to \overline{AARE} valid | 1 | 7 | ns |
| 8 | $t_{osu}(SELV-AWEL)$ Output setup time, select signals valid to \overline{AAWE} low | WS * E - 1.7 | | ns |
| 9 | $t_{oh}(AWEH-SELIV)$ Output hold time, \overline{AAWE} high to select signals invalid | WH * E - 1.8 | | ns |
| 10 | $t_d(EKO1H-AWEV)$ Delay time, AECLKOUTx high to \overline{AAWE} valid | 1.3 | 7.1 | ns |

† RS = Read setup, RST = Read strobe, RH = Read hold, WS = Write setup, WST = Write strobe, WH = Write hold. These parameters are programmed via the EMIF CE space control registers.

§ E = ECLKOUT1 period in ns for EMIFA

¶ Select signals for EMIFA include: \overline{ACE}_x , $\overline{ABE}[3:0]$, $\overline{AEA}[22:3]$, \overline{AAOE} ; and for EMIFA writes, include AED[31:0].

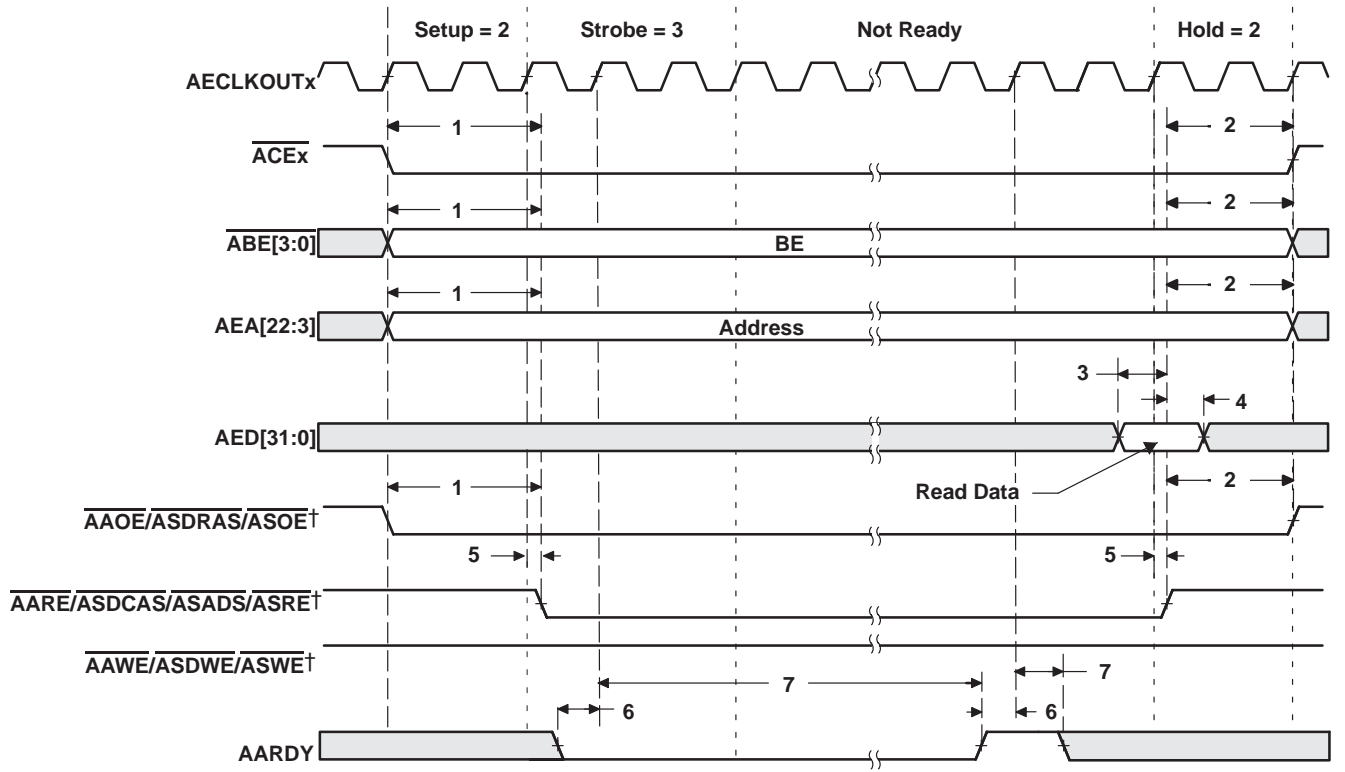

† AOE/SDRAS/SOE, ARE/SDCAS/SADS/SRE, and AWE/SDWE/SWE operate as AOE (identified under select signals), ARE, and AWE, respectively, during asynchronous memory accesses.

Figure 7-7. Asynchronous Memory Read Timing for EMIFA

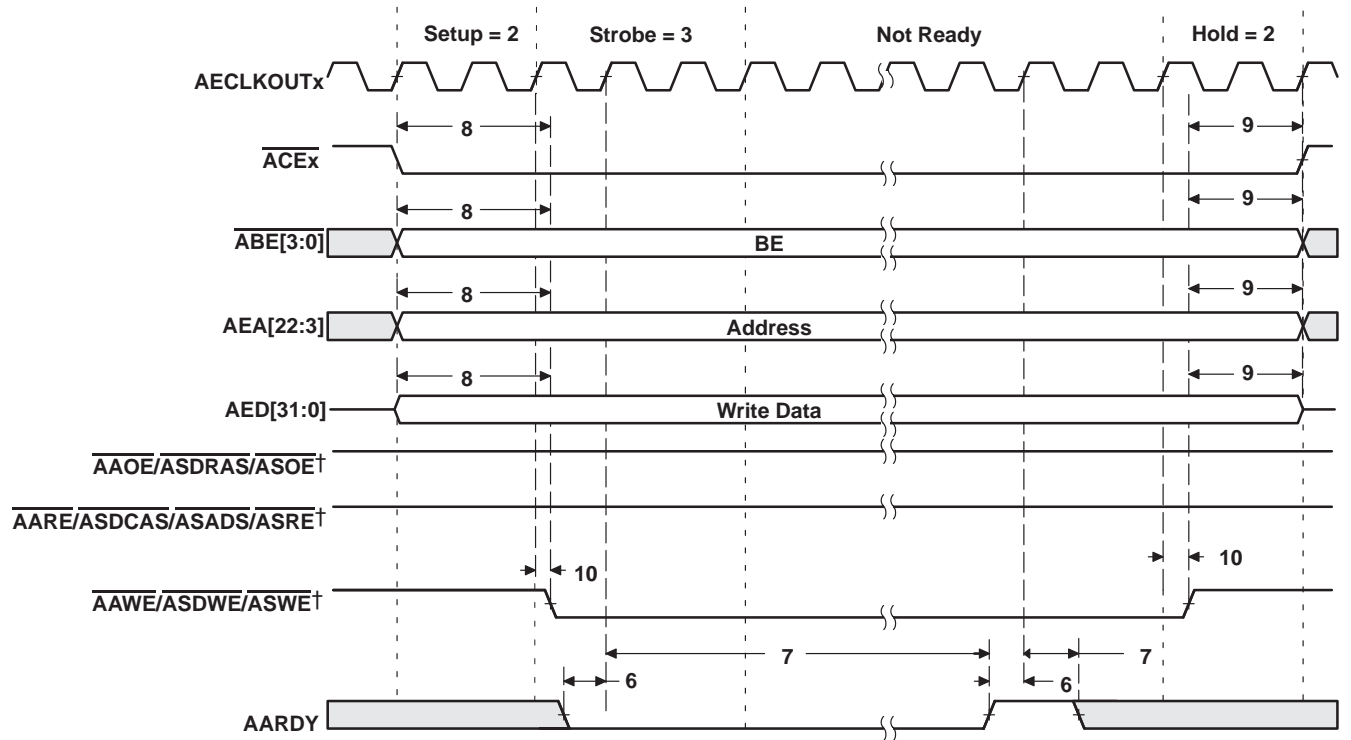

† $\overline{\text{AOE}}/\overline{\text{SDRAS}}/\overline{\text{SOE}}$, $\overline{\text{ARE}}/\overline{\text{SDCAS}}/\overline{\text{SADS}}/\overline{\text{SRE}}$, and $\overline{\text{AWE}}/\overline{\text{SDWE}}/\overline{\text{SWE}}$ operate as $\overline{\text{AOE}}$ (identified under select signals), $\overline{\text{ARE}}$, and $\overline{\text{AWE}}$, respectively, during asynchronous memory accesses.

Figure 7–8. Asynchronous Memory Write Timing for EMIFA

7.3 Programmable Synchronous Interface Timing

Table 7–10. Timing Requirements for Programmable Synchronous Interface Cycles for EMIFA Module (see Figure 7–9)

| NO. | | –500 | | –600 | | UNIT |
|-----|---|------|-----|------|-----|------|
| | | MIN | MAX | MIN | MAX | |
| 6 | $t_{su}(EDV-EKOxH)$ Setup time, read AEDx valid before AECLKOUTx high | 3.1 | | 2 | | ns |
| 7 | $t_h(EKOxH-EDV)$ Hold time, read AEDx valid after AECLKOUTx high | 1.5 | | 1.5 | | ns |

Table 7–11. Switching Characteristics Over Recommended Operating Conditions for Programmable Synchronous Interface Cycles for EMIFA Module† (see Figure 7–9–Figure 7–11)

| NO. | PARAMETER | –500 | | –600 | | UNIT |
|-----|---|------|-----|------|-----|------|
| | | MIN | MAX | MIN | MAX | |
| 1 | $t_d(EKOxH-CEV)$ Delay time, AECLKOUTx high to \overline{ACEx} valid | 1.3 | 6.4 | 1.3 | 4.9 | ns |
| 2 | $t_d(EKOxH-BEV)$ Delay time, AECLKOUTx high to \overline{BEx} valid | | 6.4 | | 4.9 | ns |
| 3 | $t_d(EKOxH-BEIV)$ Delay time, AECLKOUTx high to \overline{ABEx} invalid | 1.3 | | 1.3 | | ns |
| 4 | $t_d(EKOxH-EAV)$ Delay time, AECLKOUTx high to AEAx valid | | 6.4 | | 4.9 | ns |
| 5 | $t_d(EKOxH-EAIV)$ Delay time, AECLKOUTx high to AEAx invalid | 1.3 | | 1.3 | | ns |
| 8 | $t_d(EKOxH-ADSV)$ Delay time, AECLKOUTx high to $\overline{ASADS/ASRE}$ valid | 1.3 | 6.4 | 1.3 | 4.9 | ns |
| 9 | $t_d(EKOxH-OEV)$ Delay time, AECLKOUTx high to, \overline{ASOE} valid | 1.3 | 6.4 | 1.3 | 4.9 | ns |
| 10 | $t_d(EKOxH-EDV)$ Delay time, AECLKOUTx high to AEDx valid | | 6.4 | | 4.9 | ns |
| 11 | $t_d(EKOxH-EDIV)$ Delay time, AECLKOUTx high to AEDx invalid | 1.3 | | 1.3 | | ns |
| 12 | $t_d(EKOxH-WEV)$ Delay time, AECLKOUTx high to \overline{ASWE} valid | 1.3 | 6.4 | 1.3 | 4.9 | ns |

† The following parameters are programmable via the EMIF CE Space Secondary Control register (CExSEC):

- Read latency (SYNCRL): 0-, 1-, 2-, or 3-cycle read latency
- Write latency (SYNCWL): 0-, 1-, 2-, or 3-cycle write latency
- \overline{ACEx} assertion length (CEEXT): For standard SBSRAM or ZBT SRAM interface, \overline{ACEx} goes inactive after the final command has been issued (CEEXT = 0). For synchronous FIFO interface with glue, \overline{ACEx} is active when \overline{ASOE} is active (CEEXT = 1).
- Function of ASADS/ASRE (RENEN): For standard SBSRAM or ZBT SRAM interface, $\overline{ASADS/ASRE}$ acts as ASADS with deselect cycles (RENEN = 0). For FIFO interface, $\overline{ASADS/ASRE}$ acts as \overline{ASRE} with NO deselect cycles (RENEN = 1).
- Synchronization clock (SNCLK): Synchronized to AECLKOUT1 or AECLKOUT2

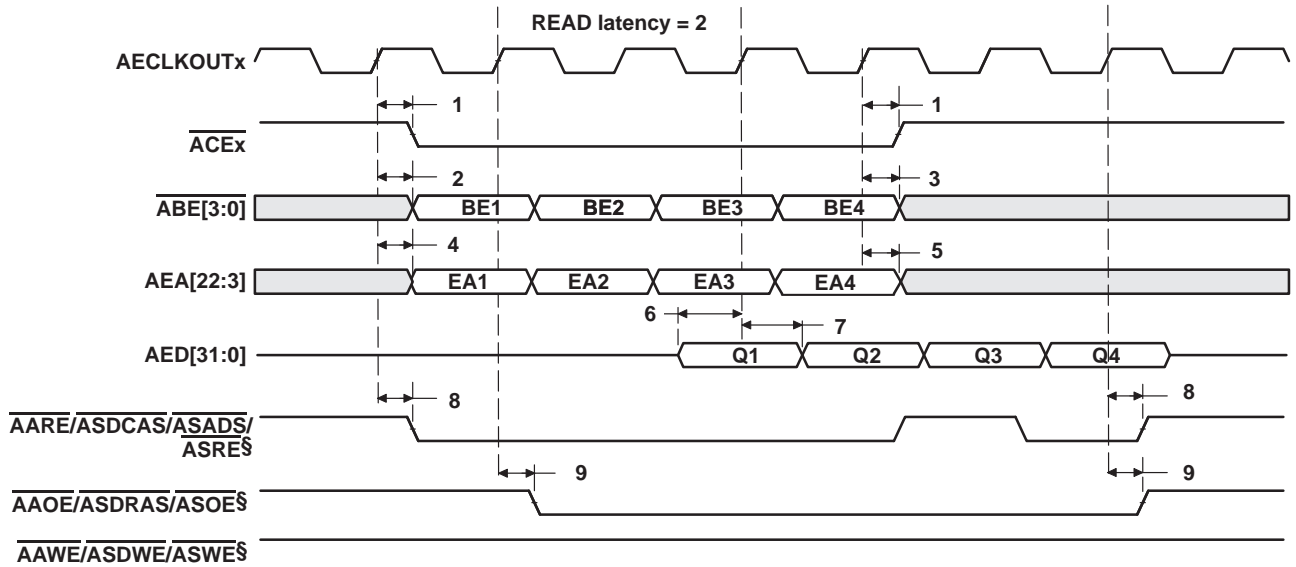

† The read latency and the length of \overline{CE}_x assertion are programmable via the SYNCRL and CEEXT fields, respectively, in the EMIFA CE Space Secondary Control register (CEXSEC). In this figure, SYNCRL = 2 and CEEXT = 0.

‡ The following parameters are programmable via the EMIF CE Space Secondary Control register (CEXSEC):

- Read latency (SYNCRL): 0-, 1-, 2-, or 3-cycle read latency
- Write latency (SYNCWL): 0-, 1-, 2-, or 3-cycle write latency
- \overline{CE}_x assertion length (CEEXT): For standard SBSRAM or ZBT SRAM interface, \overline{CE}_x goes inactive after the final command has been issued (CEEXT = 0). For synchronous FIFO interface with glue, \overline{CE}_x is active when \overline{ASOE} is active (CEEXT = 1).
- Function of $\overline{ASADS}/\overline{ASRE}$ (RENEN): For standard SBSRAM or ZBT SRAM interface, $\overline{ASADS}/\overline{ASRE}$ acts as \overline{ASADS} with deselect cycles (RENEN = 0). For FIFO interface, $\overline{ASADS}/\overline{ASRE}$ acts as \overline{ASRE} with NO deselect cycles (RENEN = 1).
- Synchronization clock (SNCCLK): Synchronized to AECLKOUT1 or AECLKOUT2

§ $\overline{AARE}/\overline{ASDCAS}/\overline{ASADS}/\overline{ASRE}$, $\overline{AAOE}/\overline{ASDRAS}/\overline{ASOE}$, and $\overline{AAWE}/\overline{ASDWE}/\overline{ASWE}$ operate as $\overline{ASADS}/\overline{ASRE}$, \overline{ASOE} , and \overline{ASWE} , respectively, during programmable synchronous interface accesses.

Figure 7–9. Programmable Synchronous Interface Read Timing for EMIFA (With Read Latency = 2)†‡

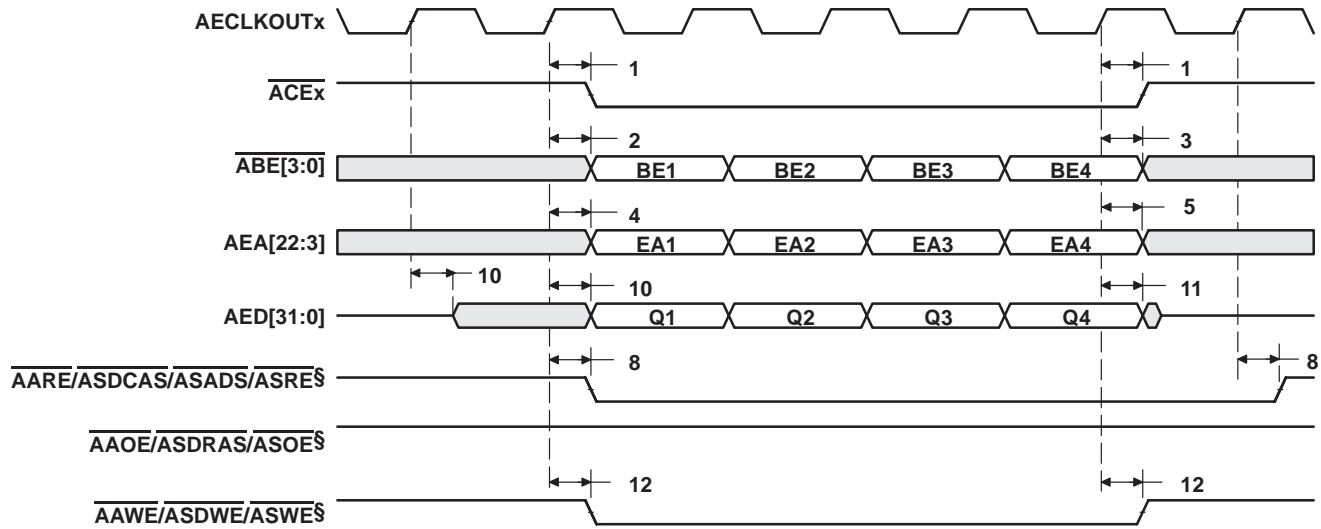

† The write latency and the length of ACEx assertion are programmable via the SYNCWL and CEEXT fields, respectively, in the EMIFA CE Space Secondary Control register (CExSEC). In this figure, SYNCWL = 0 and CEEXT = 0.

‡ The following parameters are programmable via the EMIF CE Space Secondary Control register (CExSEC):

- Read latency (SYNCRL): 0-, 1-, 2-, or 3-cycle read latency
- Write latency (SYNCWL): 0-, 1-, 2-, or 3-cycle write latency
- ACEx assertion length (CEEXT): For standard SBSRAM or ZBT SRAM interface, ACEx goes inactive after the final command has been issued (CEEXT = 0). For synchronous FIFO interface with glue, ACEx is active when ASOE is active (CEEXT = 1).
- Function of ASADS/ASRE (RENEN): For standard SBSRAM or ZBT SRAM interface, ASADS/ASRE acts as ASADS with deselect cycles (RENEN = 0). For FIFO interface, ASADS/ASRE acts as ASRE with NO deselect cycles (RENEN = 1).
- Synchronization clock (SNCLK): Synchronized to AECLKOUT1 or AECLKOUT2

§ AARE/ASDCAS/ASADS/ASRE, AAOE/ASDRAS/ASOE, and AAWE/ASDWE/ASWE operate as ASADS/ASRE, ASOE, and ASWE, respectively, during programmable synchronous interface accesses.

**Figure 7–10. Programmable Synchronous Interface Write Timing for EMIFA
(With Write Latency = 0)†‡§**

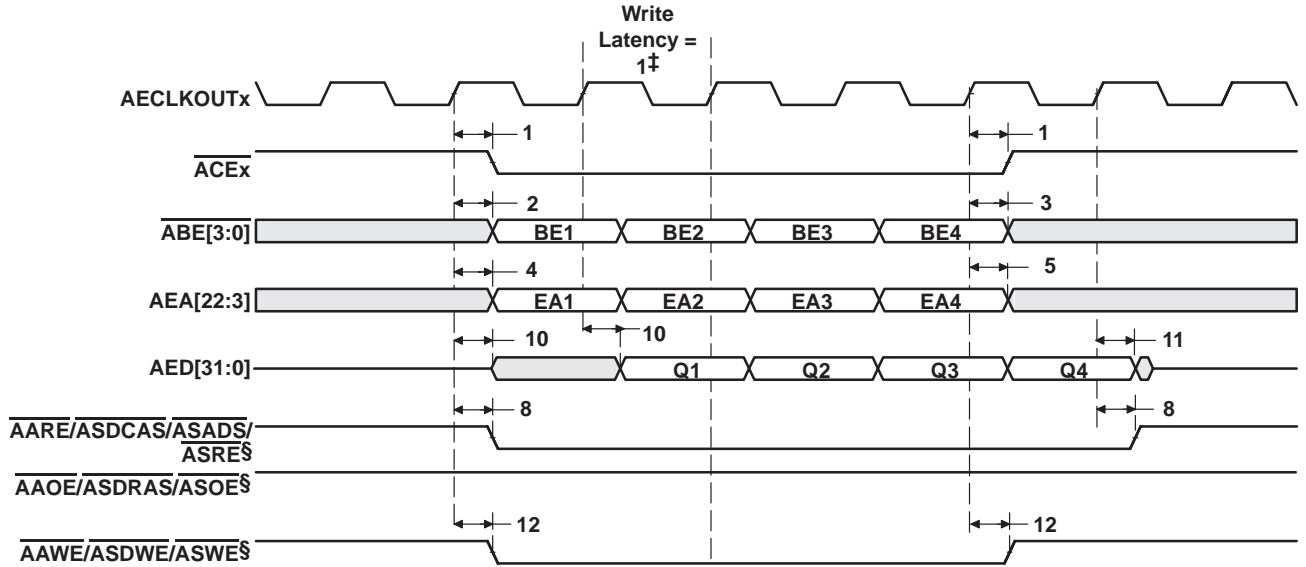

† The write latency and the length of $\overline{\text{ACEx}}$ assertion are programmable via the SYNCWL and CEEXT fields, respectively, in the EMIFA CE Space Secondary Control register (CEXSEC). In this figure, SYNCWL = 1 and CEEXT = 0.

‡ The following parameters are programmable via the EMIF CE Space Secondary Control register (CEXSEC):

- Read latency (SYNCRL): 0-, 1-, 2-, or 3-cycle read latency
- Write latency (SYNCWL): 0-, 1-, 2-, or 3-cycle write latency
- $\overline{\text{ACEx}}$ assertion length (CEEXT): For standard SBSRAM or ZBT SRAM interface, $\overline{\text{ACEx}}$ goes inactive after the final command has been issued (CEEXT = 0). For synchronous FIFO interface with glue, $\overline{\text{ACEx}}$ is active when $\overline{\text{ASOE}}$ is active (CEEXT = 1).
- Function of $\overline{\text{ASADS/ASRE}}$ (RENEN): For standard SBSRAM or ZBT SRAM interface, $\overline{\text{ASADS/ASRE}}$ acts as $\overline{\text{ASADS}}$ with deselect cycles (RENEN = 0). For FIFO interface, $\overline{\text{ASADS/ASRE}}$ acts as $\overline{\text{ASRE}}$ with NO deselect cycles (RENEN = 1).
- Synchronization clock (SNCKCLK): Synchronized to ECLKOUT1 or ECLKOUT2

§ $\overline{\text{AARE/ASDCAS/ASADS/ASRE}}$, $\overline{\text{AAOE/ASDRAS/ASOE}}$, and $\overline{\text{AAWE/ASDWE/ASWE}}$ operate as $\overline{\text{ASADS/ASRE}}$, $\overline{\text{ASOE}}$, and $\overline{\text{ASWE}}$, respectively, during programmable synchronous interface accesses.

Figure 7–11. Programmable Synchronous Interface Write Timing for EMIFA (With Write Latency = 1)†‡

7.4 Synchronous DRAM Timing

Table 7–12. Timing Requirements for Synchronous DRAM Cycles for EMIFA Module (see Figure 7–12)

| NO. | | –500 | | –600 | | UNIT |
|-----|---|------|-----|------|-----|------|
| | | MIN | MAX | MIN | MAX | |
| 6 | $t_{su}(EDV-EKO1H)$ Setup time, read AEDx valid before AECLKOUTx high | 2.1 | | 0.6 | | ns |
| 7 | $t_h(EKO1H-EDV)$ Hold time, read AEDx valid after AECLKOUTx high | 2.5 | | 1.8 | | ns |

Table 7–13. Switching Characteristics Over Recommended Operating Conditions for Synchronous DRAM Cycles for EMIFA Module (see Figure 7–12–Figure 7–19)

| NO. | PARAMETER | –500 | | –600 | | UNIT |
|-----|--|------|-----|------|-----|------|
| | | MIN | MAX | MIN | MAX | |
| 1 | $t_d(EKO1H-CEV)$ Delay time, AECLKOUTx high to \overline{ACEx} valid | 1.3 | 6.4 | 1.3 | 4.9 | ns |
| 2 | $t_d(EKO1H-BEV)$ Delay time, AECLKOUTx high to \overline{ABEx} valid | | 6.4 | | 4.9 | ns |
| 3 | $t_d(EKO1H-BEIV)$ Delay time, AECLKOUTx high to \overline{ABEx} invalid | 1.3 | | 1.3 | | ns |
| 4 | $t_d(EKO1H-EAV)$ Delay time, AECLKOUTx high to AEAx valid | | 6.4 | | 4.9 | ns |
| 5 | $t_d(EKO1H-EAIV)$ Delay time, AECLKOUTx high to AEAx invalid | 1.3 | | 1.3 | | ns |
| 8 | $t_d(EKO1H-CASV)$ Delay time, AECLKOUTx high to \overline{ASDCAS} valid | 1.3 | 6.4 | 1.3 | 4.9 | ns |
| 9 | $t_d(EKO1H-EDV)$ Delay time, AECLKOUTx high to AEDx valid | | 6.4 | | 4.9 | ns |
| 10 | $t_d(EKO1H-EDIV)$ Delay time, AECLKOUTx high to AEDx invalid | 1.3 | | 1.3 | | ns |
| 11 | $t_d(EKO1H-WEV)$ Delay time, AECLKOUTx high to \overline{ASDWE} valid | 1.3 | 6.4 | 1.3 | 4.9 | ns |
| 12 | $t_d(EKO1H-RAS)$ Delay time, AECLKOUTx high to \overline{ASDRAS} valid | 1.3 | 6.4 | 1.3 | 4.9 | ns |
| 13 | $t_d(EKO1H-ACKEV)$ Delay time, AECLKOUTx high to \overline{ASDCKE} valid | 1.3 | 6.4 | 1.3 | 4.9 | ns |
| 14 | $t_d(EKO1H-PDTV)$ Delay time, AECLKOUTx high to \overline{PDT} valid | 1.3 | 6.4 | 1.3 | 4.9 | ns |

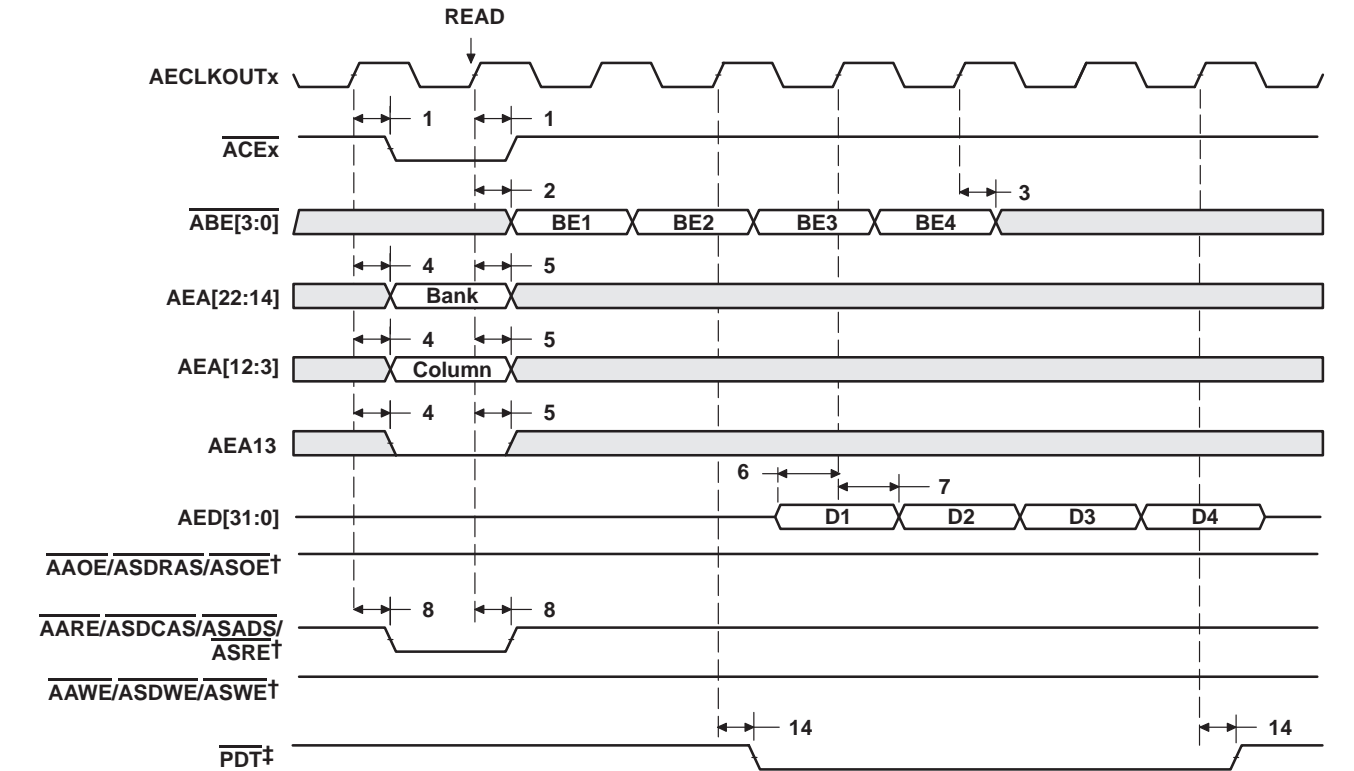

† $\overline{\text{AAOE}}/\overline{\text{ASDRAS}}/\overline{\text{ASOE}}$, $\overline{\text{AARE}}/\overline{\text{ASDCAS}}/\overline{\text{ASADS}}/\overline{\text{ASRE}}$, $\overline{\text{AAWE}}/\overline{\text{ASDWE}}/\overline{\text{ASWE}}$, and $\overline{\text{AAOE}}/\overline{\text{ASDRAS}}/\overline{\text{ASOE}}$ operate as $\overline{\text{ASDCAS}}$, $\overline{\text{ASDWE}}$, and $\overline{\text{ASDRAS}}$, respectively, during SDRAM accesses.

‡ $\overline{\text{PDT}}$ signal is only asserted when the EDMA is in PDT mode (set the PDTS bit to 1 in the EDMA options parameter RAM). For $\overline{\text{PDT}}$ read, data is not latched into EMIF. The PDTRL field in the PDT control register (PDTCTL) configures the latency of the $\overline{\text{PDT}}$ signal with respect to the data phase of a read transaction. The latency of the $\overline{\text{PDT}}$ signal for a read can be programmed to 0, 1, 2, or 3 by setting PDTRL to 00, 01, 10, or 11, respectively. PDTRL equals 00 (zero latency) in Figure 7–12.

Figure 7–12. SDRAM Read Command (CAS Latency 3) for EMIFA

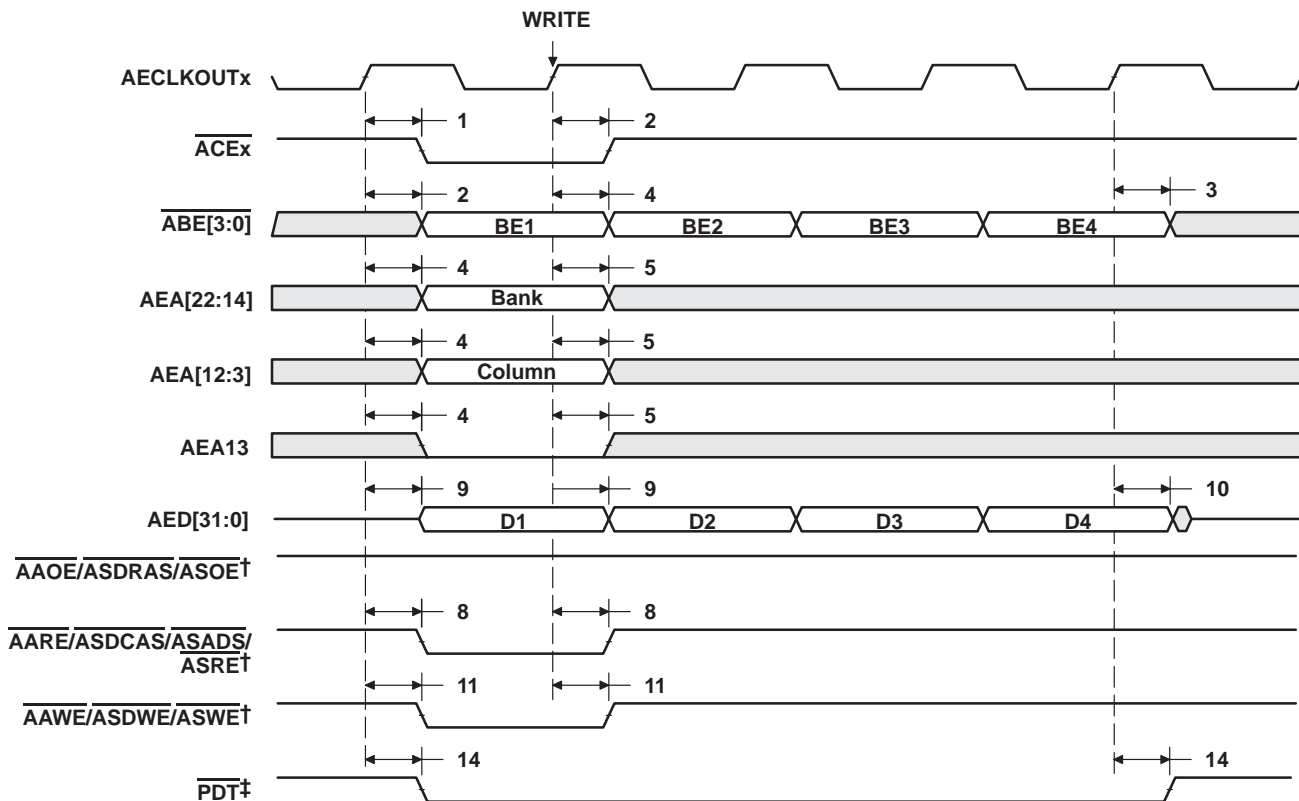

† AARE/ASDCAS/ASADS/ASRE, AAWE/ASDWE/ASWE, and AAOE/ASDRAS/ASOE operate as AsDCAS, ASDWE, and ASDRAS, respectively, during SDRAM accesses.

‡ PDT signal is only asserted when the EDMA is in PDT mode (set the PDTD bit to 1 in the EDMA options parameter RAM). For PDT write, data is not driven (in High-Z). The PDTWL field in the PDT control register (PDTCTL) configures the latency of the PDT signal with respect to the data phase of a write transaction. The latency of the PDT signal for a write transaction can be programmed to 0, 1, 2, or 3 by setting PDTWL to 00, 01, 10, or 11, respectively. PDTWL equals 00 (zero latency) in Figure 7-13.

Figure 7-13. SDRAM Write Command for EMIFA

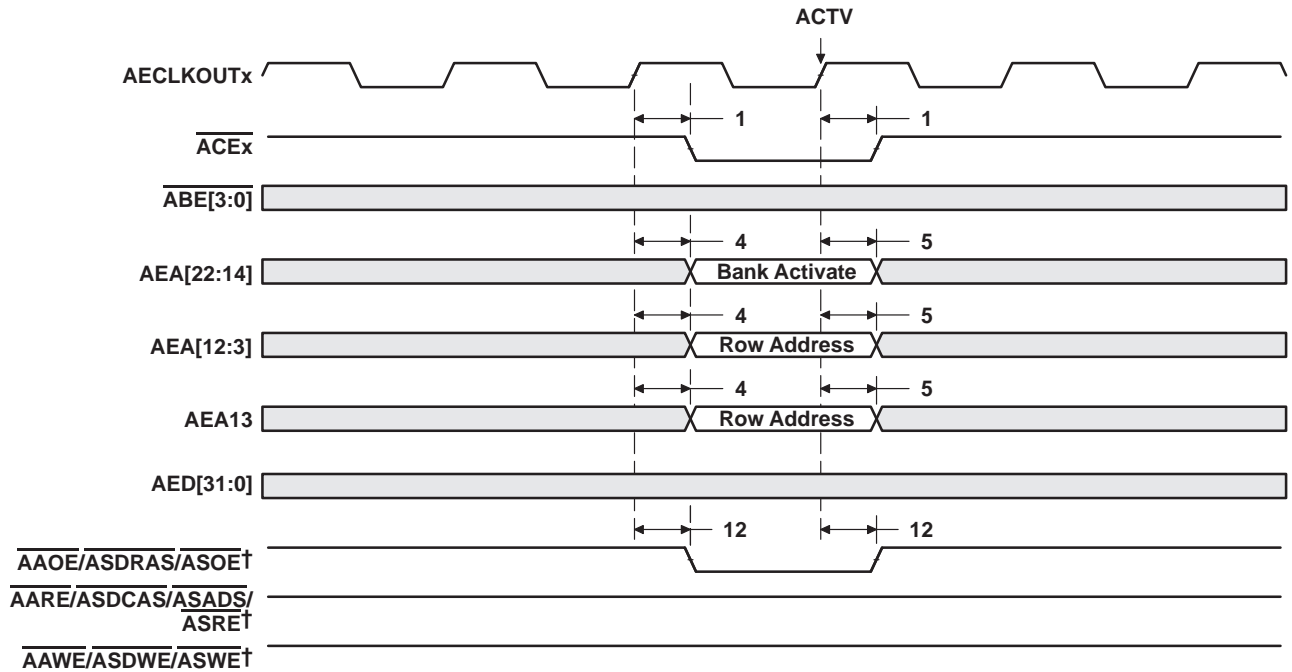

† $\overline{\text{AARE/ASDCAS/ASADS/ASRE}}$, $\overline{\text{AAWE/ASDWE/ASWE}}$, and $\overline{\text{AAOE/ASDRAS/ASOE}}$ operate as $\overline{\text{ASDCAS}}$, $\overline{\text{ASDWE}}$, and $\overline{\text{ASDRAS}}$, respectively, during SDRAM accesses.

Figure 7–14. SDRAM ACTV Command for EMIFA

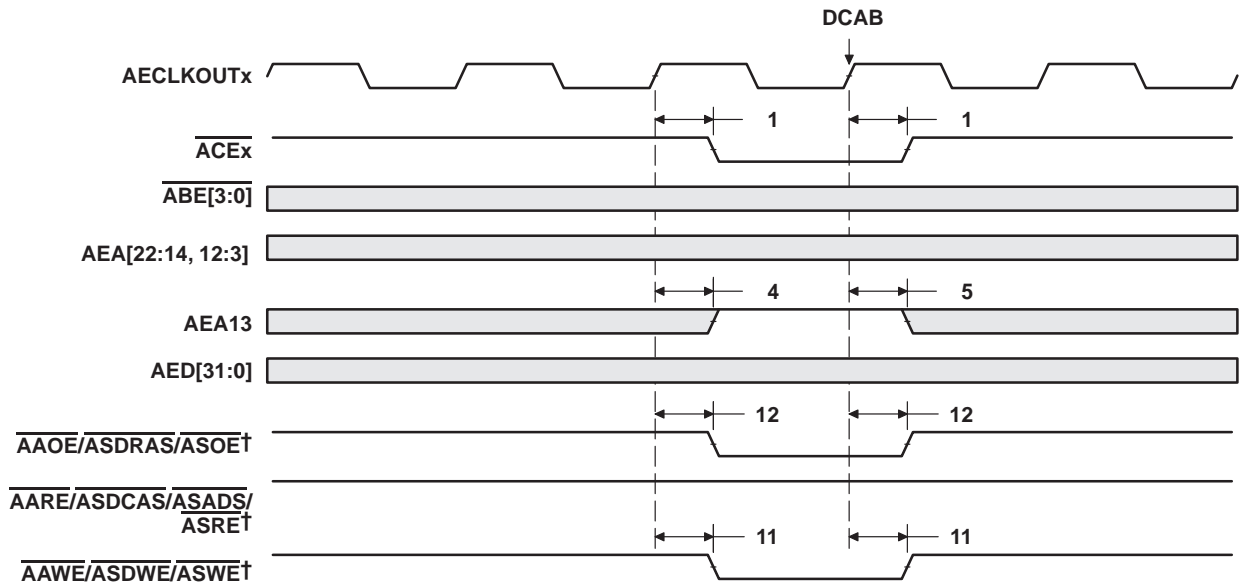

† $\overline{\text{AARE/ASDCAS/ASADS/ASRE}}$, $\overline{\text{AAWE/ASDWE/ASWE}}$, and $\overline{\text{AAOE/ASDRAS/ASOE}}$ operate as $\overline{\text{ASDCAS}}$, $\overline{\text{ASDWE}}$, and $\overline{\text{ASDRAS}}$, respectively, during SDRAM accesses.

Figure 7–15. SDRAM DCAB Command for EMIFA

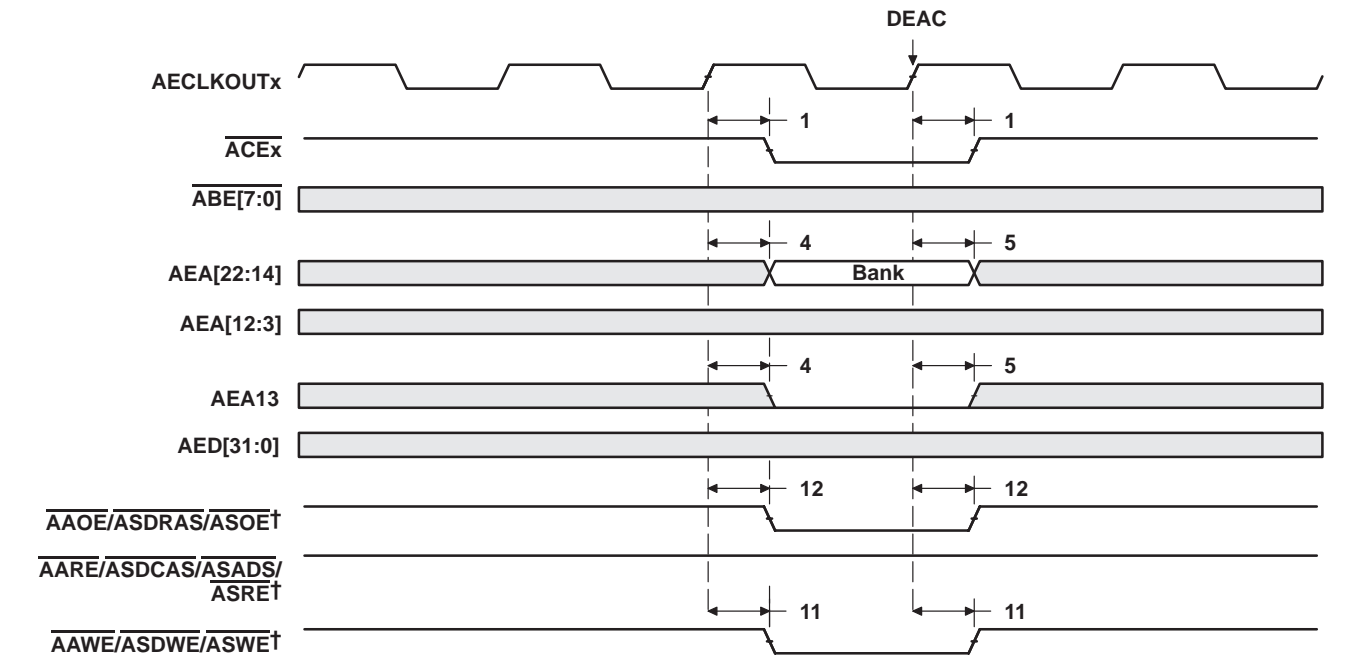

† AARE/ASDCAS/ASADS/ASRE, AAWE/ASDWE/ASWE, and AAOE/ASDRAS/ASOE operate as ASDCAS, ASDWE, and ASDRAS, respectively, during SDRAM accesses.

Figure 7–16. SDRAM DEAC Command for EMIFA

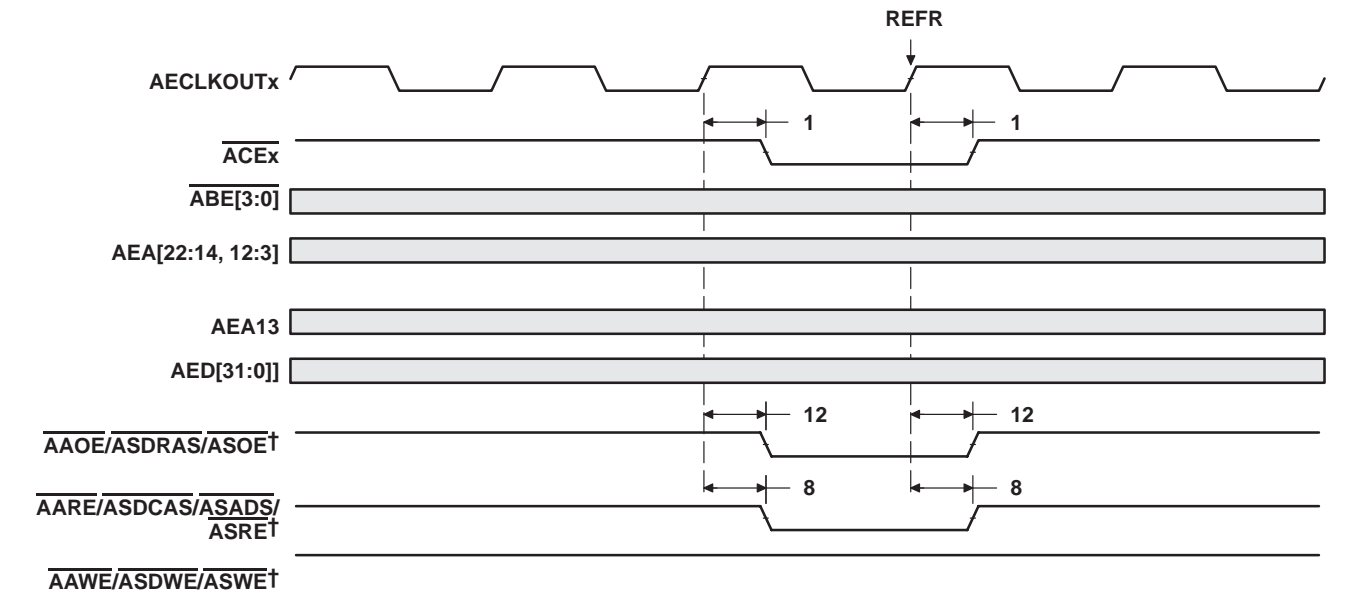

† AARE/ASDCAS/ASADS/ASRE, AAWE/ASDWE/ASWE, and AAOE/ASDRAS/ASOE operate as ASDCAS, ASDWE, and ASDRAS, respectively, during SDRAM accesses.

Figure 7–17. SDRAM REFR Command for EMIFA

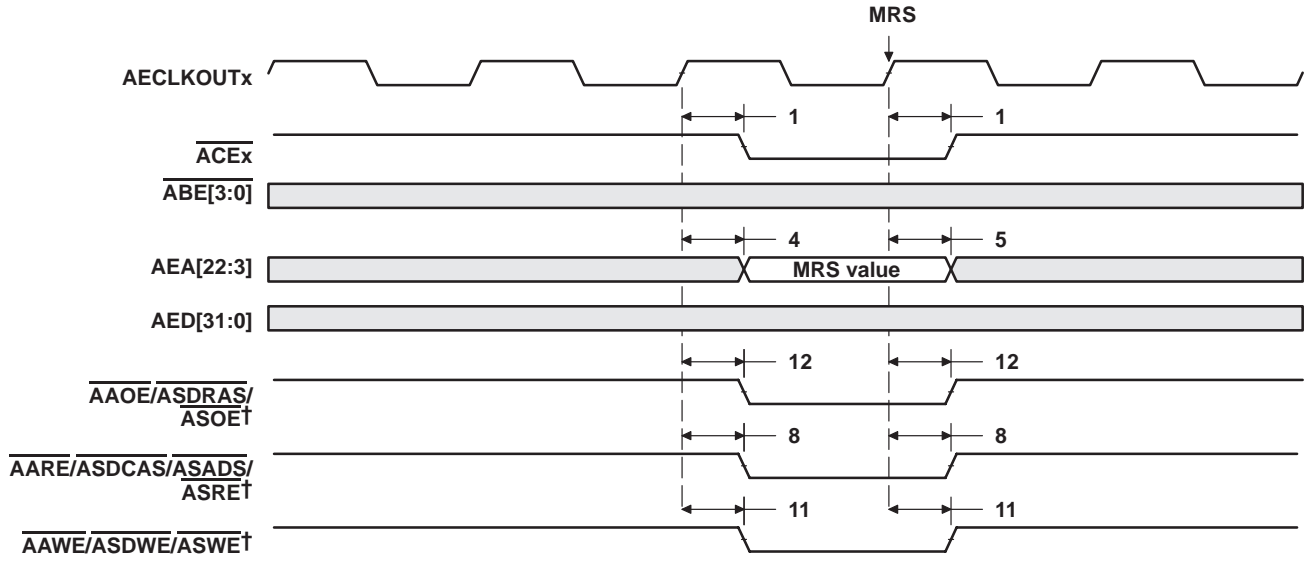

† AARE/ASDCAS/ASADS/ASRE, AAW/ASDWE/ASWE, and AAOE/ASDRAS/ASOE operate as ASDCAS, ASDWE, and ASDRAS, respectively, during SDRAM accesses.

Figure 7–18. SDRAM MRS Command for EMIFA

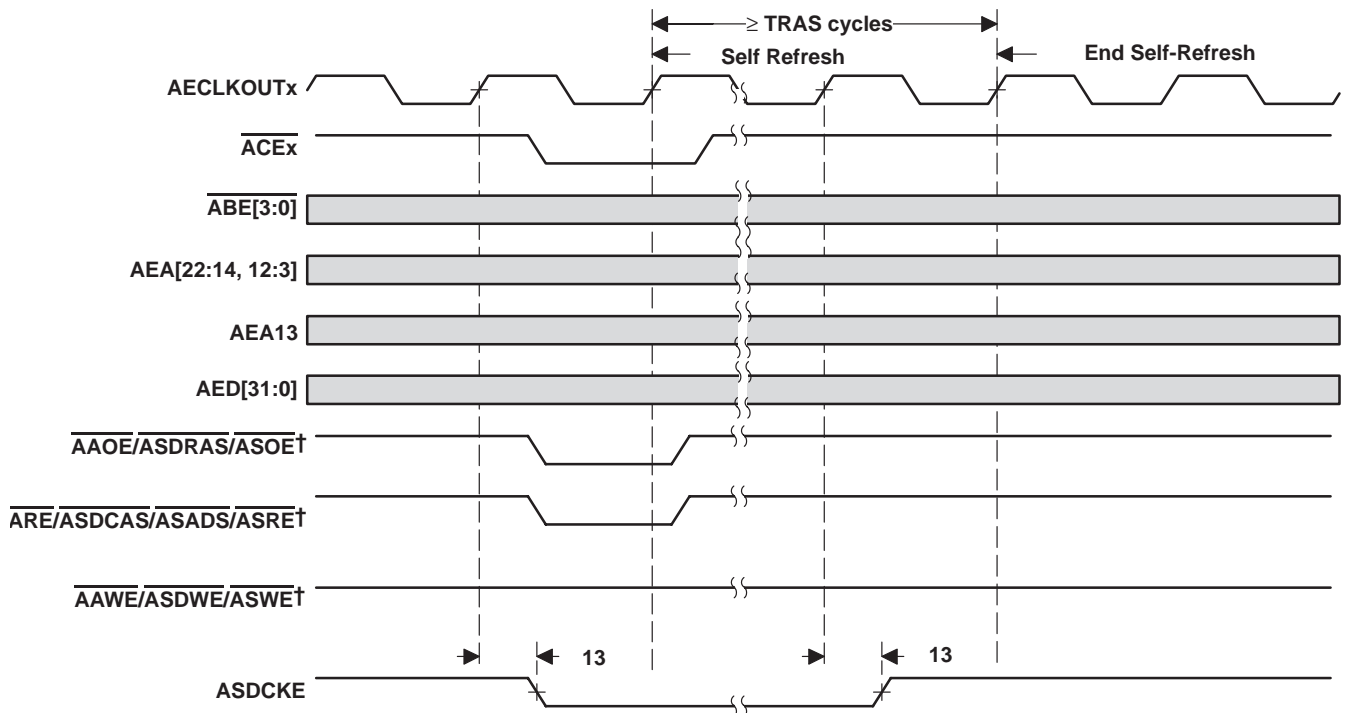

† AARE/ASDCAS/ASADS/ASRE, AAW/ASDWE/ASWE, and AAOE/ASDRAS/ASOE operate as ASDCAS, ASDWE, and ASDRAS, respectively, during SDRAM accesses.

Figure 7–19. SDRAM Self-Refresh Timing for EMIFA

7.5 HOLD/HOLDA Timing

Table 7-14. Timing Requirements for the HOLD/HOLDA Cycles for EMIFA Module† (see Figure 7-20)

| NO. | | -500 -600 | | UNIT |
|-----|--|--------------|-----|------|
| | | MIN | MAX | |
| 3 | $t_h(\text{HOLDAL-HOLDL})$ Hold time, $\overline{\text{HOLD}}$ low after $\overline{\text{HOLDA}}$ low | E | | ns |

† E = the EMIF input clock (ECLKIN, CPU/4 clock, or CPU/6 clock) period in ns for EMIFA.

Table 7-15. Switching Characteristics Over Recommended Operating Conditions for the HOLD/HOLDA Cycles for EMIFA Module†‡§ (see Figure 7-20)

| NO. | PARAMETER | -500 -600 | | UNIT |
|-----|---|--------------|-----|------|
| | | MIN | MAX | |
| 1 | $t_d(\text{HOLDL-EMHZ})$ Delay time, $\overline{\text{HOLD}}$ low to EMIFA Bus high impedance | 2E | †¶ | ns |
| 2 | $t_d(\text{EMHZ-HOLDAL})$ Delay time, EMIF Bus high impedance to $\overline{\text{HOLDA}}$ low | 0 | 2E | ns |
| 4 | $t_d(\text{HOLDH-EMLZ})$ Delay time, $\overline{\text{HOLD}}$ high to EMIF Bus low impedance | 2E | 7E | ns |
| 5 | $t_d(\text{EMLZ-HOLDAH})$ Delay time, EMIFA Bus low impedance to $\overline{\text{HOLDA}}$ high | 0 | 2E | ns |
| 6 | $t_d(\text{HOLDL-EKOHZ})$ Delay time, $\overline{\text{HOLD}}$ low to AECLKOUTx high impedance | 2E | †¶ | ns |
| 7 | $t_d(\text{HOLDH-EKOLZ})$ Delay time, $\overline{\text{HOLD}}$ high to AECLKOUTx low impedance | 2E | 7E | ns |

† E = the EMIF input clock (ECLKIN, CPU/4 clock, or CPU/6 clock) period in ns for EMIFA.

‡ EMIFA Bus consists of: $\overline{\text{ACE}}[3:0]$, $\overline{\text{ABE}}[3:0]$, $\overline{\text{AED}}[31:0]$, $\overline{\text{AEA}}[22:3]$, $\overline{\text{AARE}}/\overline{\text{ASDCAS}}/\overline{\text{ASADS}}/\overline{\text{ASRE}}$, $\overline{\text{AAOE}}/\overline{\text{ASDRAS}}/\overline{\text{ASOE}}$, and $\overline{\text{AAWE}}/\overline{\text{ASDWE}}/\overline{\text{ASWE}}$, $\overline{\text{ASDCKE}}$, $\overline{\text{ASOE3}}$, and $\overline{\text{APDT}}$.

§ The EKxHZ bits in the EMIF Global Control register (GBLCTL) determine the state of the ECLKOUTx signals during $\overline{\text{HOLDA}}$. If EKxHZ = 0, ECLKOUTx continues clocking during Hold mode. If EKxHZ = 1, ECLKOUTx goes to high impedance during Hold mode, as shown in Figure 7-20.

¶ All pending EMIF transactions are allowed to complete before $\overline{\text{HOLDA}}$ is asserted. If no bus transactions are occurring, then the minimum delay time can be achieved. Also, bus hold can be indefinitely delayed by setting NOHOLD = 1.

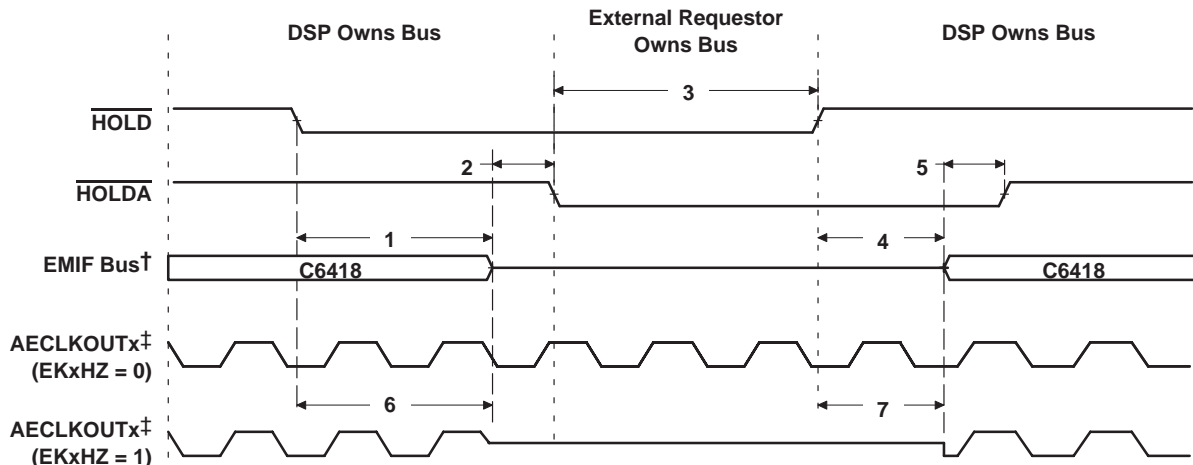

† EMIFA Bus consists of: $\overline{\text{ACE}}[3:0]$, $\overline{\text{ABE}}[3:0]$, $\overline{\text{AED}}[31:0]$, $\overline{\text{AEA}}[22:3]$, $\overline{\text{AARE}}/\overline{\text{ASDCAS}}/\overline{\text{ASADS}}/\overline{\text{ASRE}}$, $\overline{\text{AAOE}}/\overline{\text{ASDRAS}}/\overline{\text{ASOE}}$, and $\overline{\text{AAWE}}/\overline{\text{ASDWE}}/\overline{\text{ASWE}}$, $\overline{\text{ASDCKE}}$, $\overline{\text{ASOE3}}$, and $\overline{\text{APDT}}$.

‡ The EKxHZ bits in the EMIF Global Control register (GBLCTL) determine the state of the ECLKOUTx signals during $\overline{\text{HOLDA}}$. If EKxHZ = 0, ECLKOUTx continues clocking during Hold mode. If EKxHZ = 1, ECLKOUTx goes to high impedance during Hold mode, as shown in Figure 7-20.

Figure 7-20. HOLD/HOLDA Timing for EMIFA

7.6 BUSREQ Timing

Table 7-16. Switching Characteristics Over Recommended Operating Conditions for the BUSREQ Cycles for EMIFA Module (see Figure 7-21)

| NO. | PARAMETER | -500 | | -600 | | UNIT |
|-----|--|------|-----|------|-----|------|
| | | MIN | MAX | MIN | MAX | |
| 1 | $t_{d(AEKO1H-ABUSRV)}$ Delay time, AECLKOUTx high to ABUSREQ valid | 0.6 | 7.1 | 1 | 5.5 | ns |

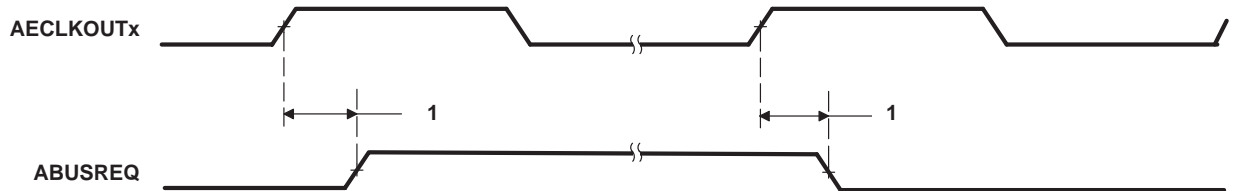

Figure 7-21. BUSREQ Timing for EMIFA

7.7 Reset Timing

Note: If a configuration pin must be routed out from the device, the internal pullup/pulldown (IPU/IPD) resistor should not be relied upon. TI recommends the use of an external pullup/pulldown resistor.

Table 7–17. Timing Requirements for Reset (see Figure 7–22)

| NO. | | –500, –600 | | UNIT |
|-----|--|-----------------------|-----|---------|
| | | MIN | MAX | |
| 1 | $t_{w(RST)}$ Width of the \overline{RESET} pulse [¶] | 250 | | μs |
| 16 | $t_{su(boot)}$ Setup time, boot configuration bits valid before \overline{RESET} high [†] | 4E or 4C [‡] | | ns |
| 17 | $t_h(boot)$ Hold time, boot configuration bits valid after \overline{RESET} high [†] | 4P [§] | | ns |

[†] LENDIAN, BOOTMODE[1:0] (AEA[22:21] pins), AECLKIN_SEL[1:0] (AEA[20:19] pins), $\overline{HPI_EN}$, and HD5 are the boot configuration pins during device reset.

[‡] E = 1/ECLKIN clock frequency in ns. C = 1/CLKIN clock frequency in ns.

Select the MIN parameter value, whichever value is larger.

[§] P = 1/CPU clock frequency in ns. For example, when running parts at 600 MHz, use P = 1.67 ns.

[¶] The device must be reset after the oscillator has stabilized. If \overline{RESETz} is low during power-up, it can be kept low until the oscillator has stabilized.
Note: a device reset does not affect the state of the oscillator.

Table 7–18. Switching Characteristics Over Recommended Operating Conditions During Reset^{§*}
(see Figure 7–22)

| NO. | PARAMETER | –500, –600 | | UNIT |
|-----|--|------------|---------------|------|
| | | MIN | MAX | |
| 2 | $t_d(\text{RSTL-ECKI})$ Delay time, $\overline{\text{RESET}}$ low to ECLKIN synchronized internally | 2E | 3P + 20E | ns |
| 3 | $t_d(\text{RSTH-ECKI})$ Delay time, $\overline{\text{RESET}}$ high to ECLKIN synchronized internally | 2E | 8P + 20E | ns |
| 4 | $t_d(\text{RSTL-ECKO1HZ})$ Delay time, $\overline{\text{RESET}}$ low to ECLKOUT1 high impedance | 2E | | ns |
| 5 | $t_d(\text{RSTH-ECKO1V})$ Delay time, $\overline{\text{RESET}}$ high to ECLKOUT1 valid | | 8P + 20E | ns |
| 6 | $t_d(\text{RSTL-EMIFZH})$ Delay time, $\overline{\text{RESET}}$ low to EMIF Z high impedance | 2E | 3P + 4E | ns |
| 7 | $t_d(\text{RSTH-EMIFZV})$ Delay time, $\overline{\text{RESET}}$ high to EMIF Z valid | 16E | 8P + 20E | ns |
| 8 | $t_d(\text{RSTL-EMIFHV})$ Delay time, $\overline{\text{RESET}}$ low to EMIF high group invalid | 2E | | ns |
| 9 | $t_d(\text{RSTH-EMIFHV})$ Delay time, $\overline{\text{RESET}}$ high to EMIF high group valid | | 8P + 20E | ns |
| 10 | $t_d(\text{RSTL-EMIFLV})$ Delay time, $\overline{\text{RESET}}$ low to EMIF low group invalid | 2E | | ns |
| 11 | $t_d(\text{RSTH-EMIFLV})$ Delay time, $\overline{\text{RESET}}$ high to EMIF low group valid | | 8P + 20E | ns |
| 12 | $t_d(\text{RSTL-HIGHIV})$ Delay time, $\overline{\text{RESET}}$ low to high group invalid | 0 | | ns |
| 13 | $t_d(\text{RSTH-HIGHV})$ Delay time, $\overline{\text{RESET}}$ high to high group valid | | 11P | ns |
| 14 | $t_d(\text{RSTL-ZHZ})$ Delay time, $\overline{\text{RESET}}$ low to Z group high impedance | 0 | | ns |
| 15 | $t_d(\text{RSTH-ZV})$ Delay time, $\overline{\text{RESET}}$ high to Z group valid | 2P | 8P | ns |
| 18 | $t_d(\text{OSCSTART})$ Delay time, Internal oscillator startup time | | 41032 x OSCIN | ns |

[§] P = 1/CPU clock frequency in ns. For example, when running parts at 600 MHz, use P = 1.67 ns.

[¶] The device must be reset after the oscillator has stabilized. If $\overline{\text{RESET}}$ is low during power-up, it can be kept low until the oscillator has stabilized.

Note: a device reset does not affect the state of the oscillator.

E = the EMIF input clock (ECLKIN, CPU/4 clock, or CPU/6 clock) period in ns for EMIFA.

|| Assuming core power supply has stabilized at recommended operating conditions.

☆EMIF Z group consists of: AEA[22:3], AED[31:0], ACE[3:0], ABE[3:0], AARE/ASDCAS/ASADS/ASRE,AAWE/ASDWE/ASWE, and AAOE/ASDRAS/ASOE, ASOE3, ASDCKE, APDT., and AECLKOUT1

EMIF high group consists of: AHOLDA (when the corresponding HOLD input is high)

EMIF low group consists of: ABUSREQ; AHOLDA (when the corresponding HOLD input is low)

High group consists of: HRDY (when HPI is enabled, otherwise in Z group)

Z group consists of: CLKX0, CLKX1, FSX0, FSX1, DX0, DX1, CLKS0, CLKS1, DR0, DR1, CLKR0, CLKR1, FSR0, FSR1, TOUT0/HPI_EN, TOUT1/LENDIAN, GP0[7:0], HD[7:0], HD[15:8]/GP0[15:8], HD[21:16]/AXR1[5:0], HD22/AFSX1, HD23/AFSR1, HD24/ACLKX1, HD25/ACLKR1, HD26/AHCLKR1, HD27/AHCLKX1, HD28/AMUTE1, HD29/AMUTEIN1, HD30, HD31, HRDY (when HPI is disabled), HDS2, HDS1/ACLKR1[3], HCS/ACLKR1[2], HAS/ACLKR1[1], HRW/AFSR1[3], HHWIL/AFSR1[2] (16-bit HPI mode only), HCNTL0/AFSR1[1], HCNTL1, HINT, ACLKR0, AFSR0, AHCLKR0, AMUTEIN0, AMUTE0, AXR0[5:0], SDA1, SCL1, SDA0, SCL0, TDO, and EMU[11:0]

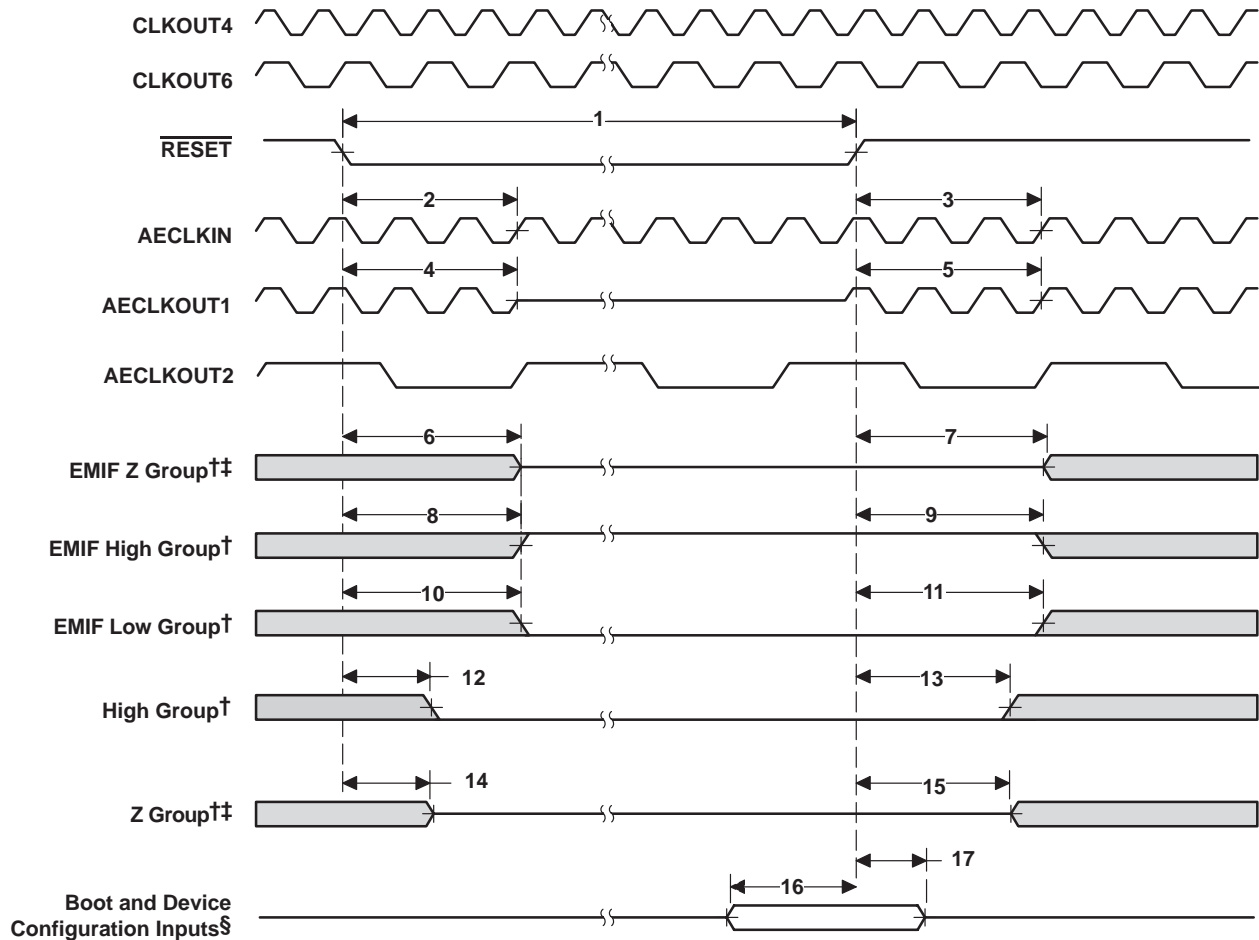

† EMIF Z group consists of: AEA[22:3], AED[31:0], ACE[3:0], ABE[3:0], AARE/ASDCAS/ASADS/ASRE, AAWE/ASDWE/ASWE, and AAOE/ASDRAS/ASOE, ASOE3, ASDCKE, APDT., and AECLKOUT1

EMIF high group consists of: AHOLDA (when the corresponding HOLD input is high)

EMIF low group consists of: ABUSREQ; AHOLDA (when the corresponding HOLD input is low)

High group consists of: HRDY (when HPI is enabled, otherwise in Z group)

Z group consists of: CLKX0, CLKX1, FSX0, FSX1, DX0, DX1, CLKS0, CLKS1, DR0, DR1, CLKR0, CLKR1, FSR0, FSR1, TOUT0/HPI_EN, TOUT1/LENDIAN, GP0[7:0], HD[7:0], HD[15:8]/GP0[15:8], HD[21:16]/AXR1[5:0], HD22/AFSX1, HD23/AFSR1, HD24/ACLKX1, HD25/ACLKR1, HD26/AHCLKR1, HD27/AHCLKX1, HD28/AMUTE1, HD29/AMUTEIN1, HD30, HD31, HRDY (when HPI is disabled), HDS2, HDS1/ACLKR1[3], HCS/ACLKR1[2], HAS/ACLKR1[1], HR/W/AFSR1[3], HHWIL/AFSR1[2] (16-bit HPI mode only), HCNTL0/AFSR1[1], HCNTL1, HINT, ACLKR0, AFSR0, AHCLKR0, AMUTEIN0, AMUTE0, AXR0[5:0], SDA1, SCL1, SDA0, SCL0, TDO, and EMU[11:0]

‡ If LENDIAN, BOOTMODE[1:0] (AEA[22:21] pins), AECLKIN_SEL[1:0] (AEA[20:19] pins), HPI_EN, and HD5 are actively driven, care must be taken to ensure no timing contention between parameters 6, 7, 14, 15, 16, and 17.

§ Boot and Device Configurations Inputs (during reset) include: LENDIAN, BOOTMODE[1:0] (AEA[22:21] pins), AECLKIN_SEL[1:0] (AEA[20:19] pins), HPI_EN, and HD5.

Figure 7–22. Reset Timing†

7.8 External Interrupt Timing

Table 7–19. Timing Requirements for External Interrupts† (see Figure 7–23)

| NO. | | | –500 –600 | | UNIT |
|-----|--------------------|---|--------------|-----|------|
| | | | MIN | MAX | |
| 1 | $t_w(\text{LOW})$ | Width of the NMI interrupt pulse low | 4P | | ns |
| | | Width of the EXT_INT interrupt pulse low | 8P | | ns |
| 2 | $t_w(\text{HIGH})$ | Width of the NMI interrupt pulse high | 4P | | ns |
| | | Width of the EXT_INT interrupt pulse high | 8P | | ns |

† P = 1/CPU clock frequency in ns. For example, when running parts at 600 MHz, use P = 1.67 ns.

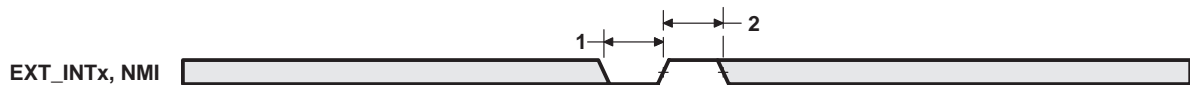

Figure 7–23. External/NMI Interrupt Timing

7.9 Multichannel Audio Serial Port (McASP) Timing

Table 7–20. Timing Requirements for McASP (see Figure 7–24 and Figure 7–27)

| NO. | | | –500 –600 | | UNIT |
|-----|---------------------------|--|--------------|-------|------|
| | | | MIN | MAX | |
| 1 | $t_c(\text{AHCKRX})$ | Cycle time, AHCLKR/X | | 20 | ns |
| 2 | $t_w(\text{AHCKRX})$ | Pulse duration, AHCLKR/X high or low | | 10 | ns |
| 3 | $t_c(\text{CKRX})$ | Cycle time, ACLKR/X | ACLKR/X ext | 25 | ns |
| 4 | $t_w(\text{CKRX})$ | Pulse duration, ACLKR/X high or low | ACLKR/X ext | 12.25 | ns |
| 5 | $t_{su}(\text{FRXC-KRX})$ | Setup time, AFSR/X input valid before ACLKR/X latches data | ACLKR/X int | 5 | ns |
| | | | ACLKR/X ext | 5 | ns |
| 6 | $t_h(\text{CKRX-FRX})$ | Hold time, AFSR/X input valid after ACLKR/X latches data | ACLKR/X int | 5 | ns |
| | | | ACLKR/X ext | 5 | ns |
| 7 | $t_{su}(\text{AXR-CKRX})$ | Setup time, AXR input valid before ACLKR/X latches data | ACLKR/X int | 5 | ns |
| | | | ACLKR/X ext | 5 | ns |
| 8 | $t_h(\text{CKRX-AXR})$ | Hold time, AXR input valid after ACLKR/X latches data | ACLKR/X int | 5 | ns |
| | | | ACLKR/X ext | 5 | ns |

Table 7–21. Switching Characteristics Over Recommended Operating Conditions for McASP (see Figure 7–25 and Figure 7–27)

| NO. | PARAMETER | | –500 –600 | | UNIT | |
|-----|------------------------------|---|--------------|------|------|----|
| | | | MIN | MAX | | |
| 9 | $t_c(\text{AHCKRX})$ | Cycle time, AHCLKR/X | | 20 | ns | |
| 10 | $t_w(\text{AHCKRX})$ | Pulse duration, AHCLKR/X high or low | | 10 | ns | |
| 11 | $t_c(\text{CKRX})$ | Cycle time, ACLKR/X | ACLKR/X int | 33 | ns | |
| 12 | $t_w(\text{CKRX})$ | Pulse duration, ACLKR/X high or low | ACLKR/X int | 16.5 | ns | |
| 13 | $t_d(\text{CKRX-FRX})$ | Delay time, ACLKR/X transmit edge to AFSX/R output valid | ACLKR/X int | –1 | 5 | ns |
| | | | ACLKR/X ext | 2 | 12 | ns |
| 14 | $t_d(\text{CKRX-AXRV})$ | Delay time, ACLKR/X transmit edge to AXR output valid | ACLKR/X int | –1 | 5 | ns |
| | | | ACLKR/X ext | 2 | 12 | ns |
| 15 | $t_{dis}(\text{CKRX-AXRHZ})$ | Disable time, AXR high impedance following last data bit from ACLKR/X transmit edge | ACLKR/X int | 0 | 10 | ns |
| | | | ACLKR/X ext | 0 | 10 | ns |

MULTICHANNEL AUDIO SERIAL PORT (McASP) TIMING (CONTINUED)

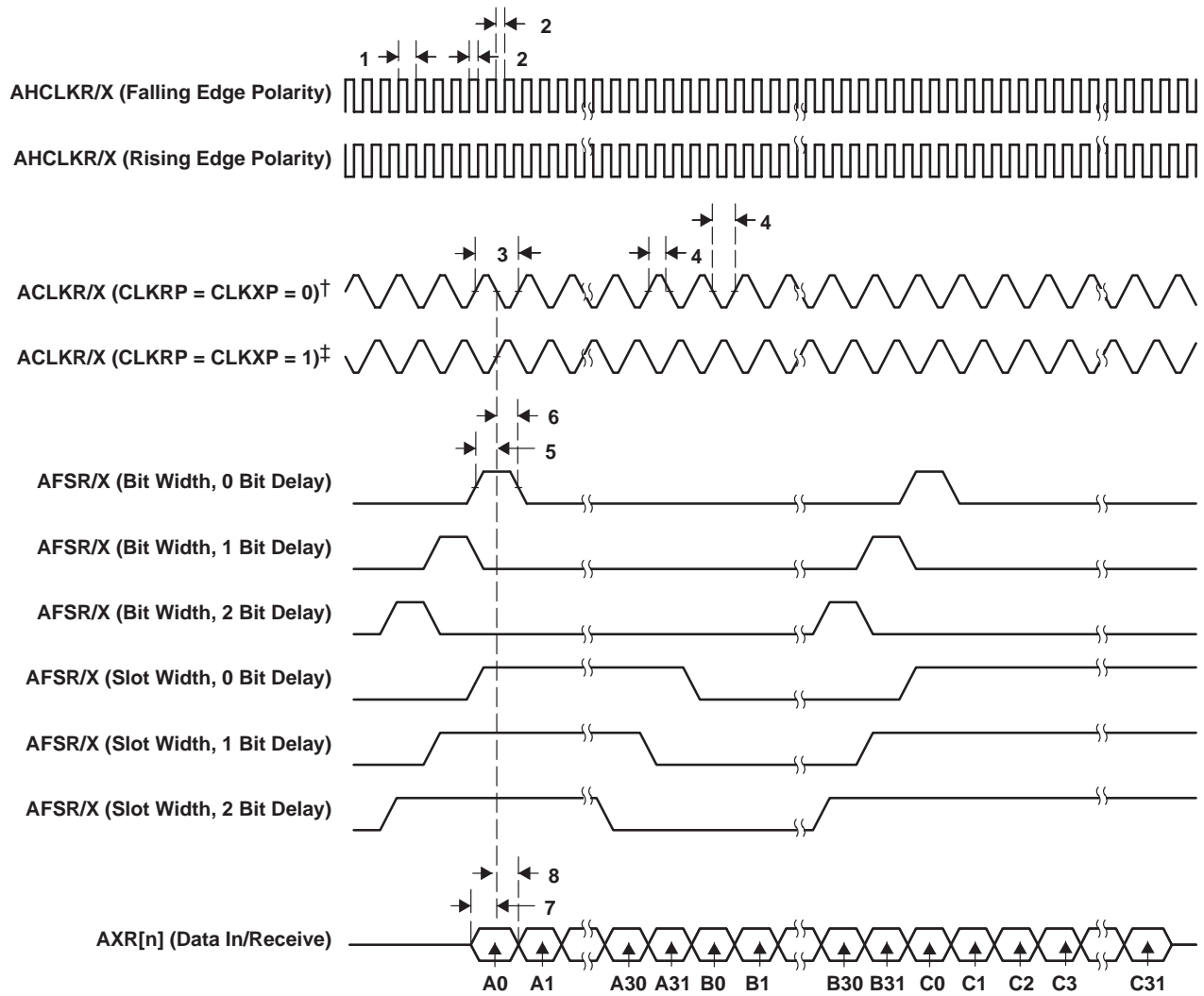

† For CLKRP = CLKXP = 0, the McASP transmitter is configured for rising edge (to shift data out) and the McASP receiver is configured for falling edge (to shift data in).

‡ For CLKRP = CLKXP = 1, the McASP transmitter is configured for falling edge (to shift data out) and the McASP receiver is configured for rising edge (to shift data in).

Figure 7–26. McASP Input Timings

MULTICHANNEL AUDIO SERIAL PORT (McASP) TIMING (CONTINUED)

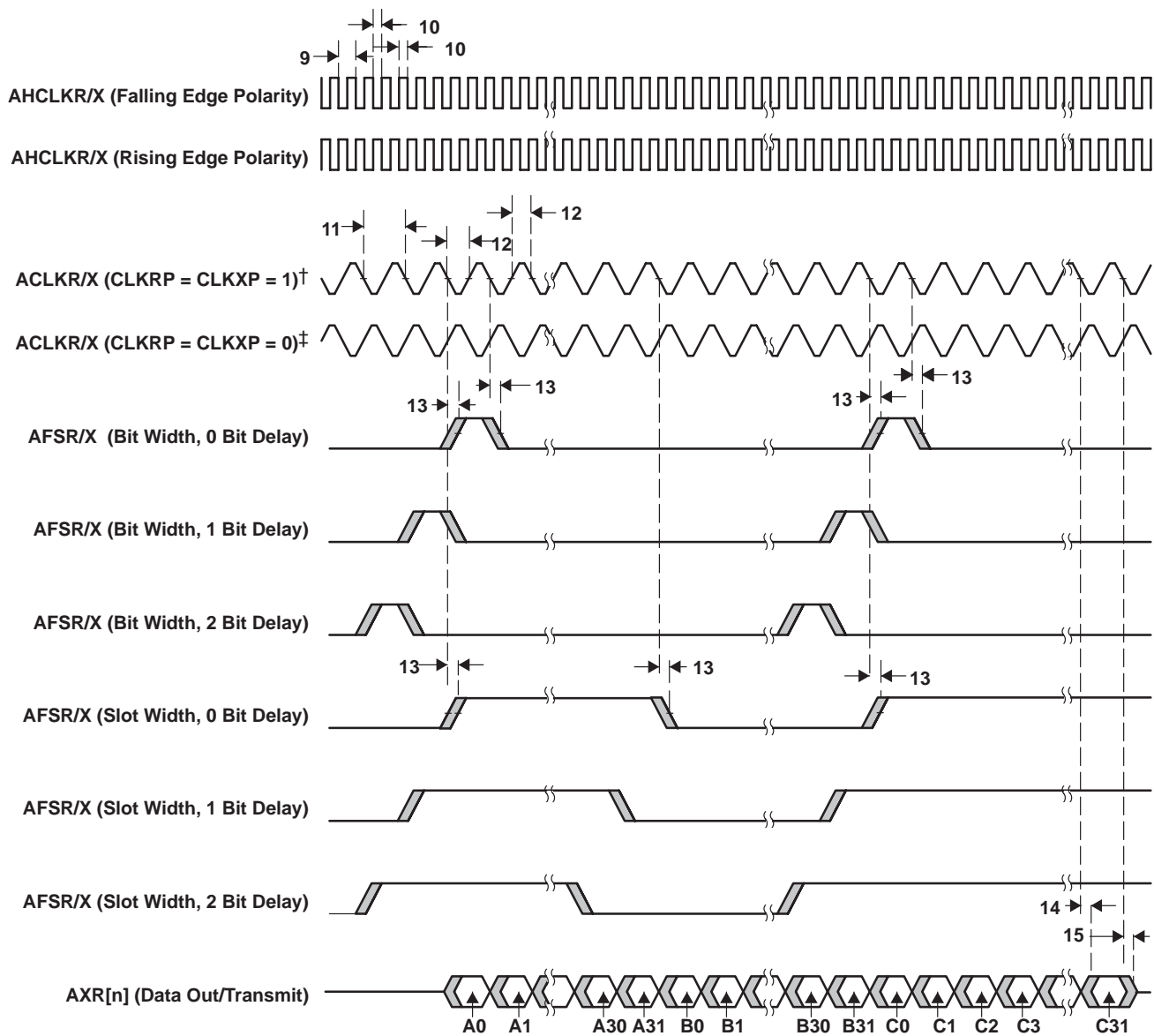

† For CLKRP = CLKXP = 1, the McASP transmitter is configured for falling edge (to shift data out) and the McASP receiver is configured for rising edge (to shift data in).
 ‡ For CLKRP = CLKXP = 0, the McASP transmitter is configured for rising edge (to shift data out) and the McASP receiver is configured for falling edge (to shift data in).

Figure 7–27. McASP Output Timings

7.10 Inter-Integrated Circuits (I2C) Timing

Table 7–22. Timing Requirements for I2C Timings† (see Figure 7–28)

| NO. | | –500 –600 | | | | UNIT |
|-----|----------------------------|---|-----|-----------|------------------|---------------|
| | | STANDARD MODE | | FAST MODE | | |
| | | MIN | MAX | MIN | MAX | |
| 1 | $t_c(\text{SCL})$ | Cycle time, SCL | | 10 | 2.5 | μs |
| 2 | $t_{su}(\text{SCLH-SDAL})$ | Setup time, SCL high before SDA low (for a repeated START condition) | | 4.7 | 0.6 | μs |
| 3 | $t_h(\text{SCLL-SDAL})$ | Hold time, SCL low after SDA low (for a START and a repeated START condition) | | 4 | 0.6 | μs |
| 4 | $t_w(\text{SCLL})$ | Pulse duration, SCL low | | 4.7 | 1.3 | μs |
| 5 | $t_w(\text{SCLH})$ | Pulse duration, SCL high | | 4 | 0.6 | μs |
| 6 | $t_{su}(\text{SDAV-SDLH})$ | Setup time, SDA valid before SCL high | | 250 | 100‡ | ns |
| 7 | $t_h(\text{SDA-SDLL})$ | Hold time, SDA valid after SCL low (For I2C bus™ devices) | | 0§ | 0§ 0.9¶ | μs |
| 8 | $t_w(\text{SDAH})$ | Pulse duration, SDA high between STOP and START conditions | | 4.7 | 1.3 | μs |
| 9 | $t_r(\text{SDA})$ | Rise time, SDA | | 1000 | $20 + 0.1C_b^\#$ | 300 ns |
| 10 | $t_r(\text{SCL})$ | Rise time, SCL | | 1000 | $20 + 0.1C_b^\#$ | 300 ns |
| 11 | $t_f(\text{SDA})$ | Fall time, SDA | | 300 | $20 + 0.1C_b^\#$ | 300 ns |
| 12 | $t_f(\text{SCL})$ | Fall time, SCL | | 300 | $20 + 0.1C_b^\#$ | 300 ns |
| 13 | $t_{su}(\text{SCLH-SDAH})$ | Setup time, SCL high before SDA high (for STOP condition) | | 4 | 0.6 | μs |
| 14 | $t_w(\text{SP})$ | Pulse duration, spike (must be suppressed) | | | 0 50 | ns |
| 15 | $C_b^\#$ | Capacitive load for each bus line | | 400 | 400 | pF |

† The I2C pins SDA and SCL do not feature fail-safe I/O buffers. These pins could potentially draw current when the device is powered down.
 ‡ A Fast-mode I2C-bus™ device can be used in a Standard-mode I2C-bus™ system, but the requirement $t_{su}(\text{SDA-SCLH}) \geq 250$ ns must then be met. This will automatically be the case if the device does not stretch the LOW period of the SCL signal. If such a device does stretch the LOW period of the SCL signal, it must output the next data bit to the SDA line $t_r \text{ max} + t_{su}(\text{SDA-SCLH}) = 1000 + 250 = 1250$ ns (according to the Standard-mode I2C-Bus Specification) before the SCL line is released.
 § A device must internally provide a hold time of at least 300 ns for the SDA signal (referred to the V_{IHmin} of the SCL signal) to bridge the undefined region of the falling edge of SCL.
 ¶ The maximum $t_h(\text{SDA-SCLL})$ has only to be met if the device does not stretch the low period [$t_w(\text{SCLL})$] of the SCL signal.
 # C_b = total capacitance of one bus line in pF. If mixed with HS-mode devices, faster fall-times are allowed.

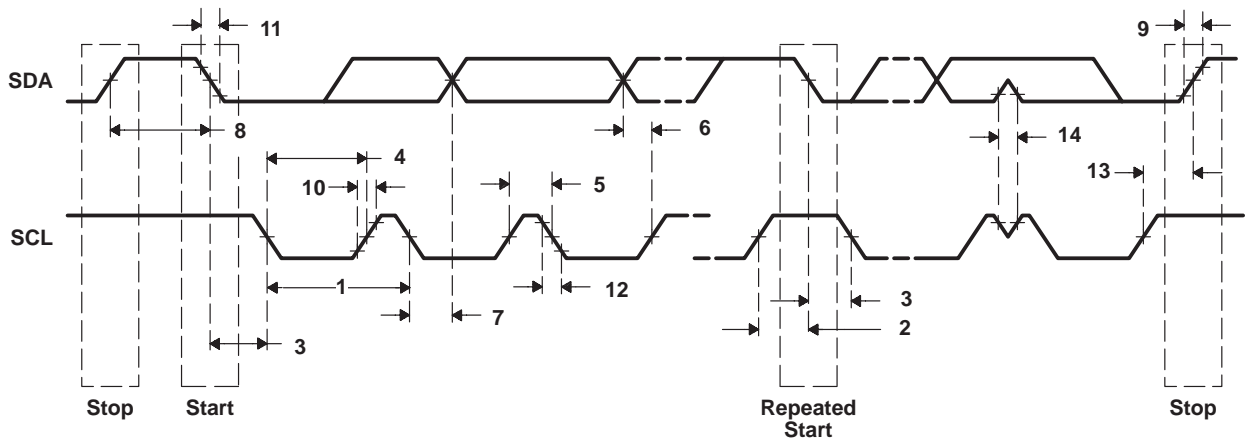

Figure 7–28. I2C Receive Timings

Table 7–23. Switching Characteristics for I2C Timings† (see Figure 7–29)

| NO. | PARAMETER | –500 –600 | | | | UNIT |
|-----|---|------------------|-----|-----------------------|-----|---------------|
| | | STANDARD MODE | | FAST MODE | | |
| | | MIN | MAX | MIN | MAX | |
| 16 | $t_c(\text{SCL})$ Cycle time, SCL | 10 | | 2.5 | | μs |
| 17 | $t_d(\text{SCLH-SDAL})$ Delay time, SCL high to SDA low (for a repeated START condition) | 4.7 | | 0.6 | | μs |
| 18 | $t_d(\text{SDAL-SCLL})$ Delay time, SDA low to SCL low (for a START and a repeated START condition) | 4 | | 0.6 | | μs |
| 19 | $t_w(\text{SCLL})$ Pulse duration, SCL low | 4.7 | | 1.3 | | μs |
| 20 | $t_w(\text{SCLH})$ Pulse duration, SCL high | 4 | | 0.6 | | μs |
| 21 | $t_d(\text{SDAV-SDLH})$ Delay time, SDA valid to SCL high | 250 | | 100 | | ns |
| 22 | $t_v(\text{SDLL-SDAV})$ Valid time, SDA valid after SCL low (For I ² C bus™ devices) | 0 | | 0 | 0.9 | μs |
| 23 | $t_w(\text{SDAH})$ Pulse duration, SDA high between STOP and START conditions | 4.7 | | 1.3 | | μs |
| 24 | $t_r(\text{SDA})$ Rise time, SDA | 1000 | | $20 + 0.1C_b^\dagger$ | 300 | ns |
| 25 | $t_r(\text{SCL})$ Rise time, SCL | 1000 | | $20 + 0.1C_b^\dagger$ | 300 | ns |
| 26 | $t_f(\text{SDA})$ Fall time, SDA | 300 | | $20 + 0.1C_b^\dagger$ | 300 | ns |
| 27 | $t_f(\text{SCL})$ Fall time, SCL | 300 | | $20 + 0.1C_b^\dagger$ | 300 | ns |
| 28 | $t_d(\text{SCLH-SDAH})$ Delay time, SCL high to SDA high (for STOP condition) | 4 | | 0.6 | | μs |
| 29 | C_p Capacitance for each I2C pin | | 10 | | 10 | pF |

† C_b = total capacitance of one bus line in pF. If mixed with HS-mode devices, faster fall-times are allowed.

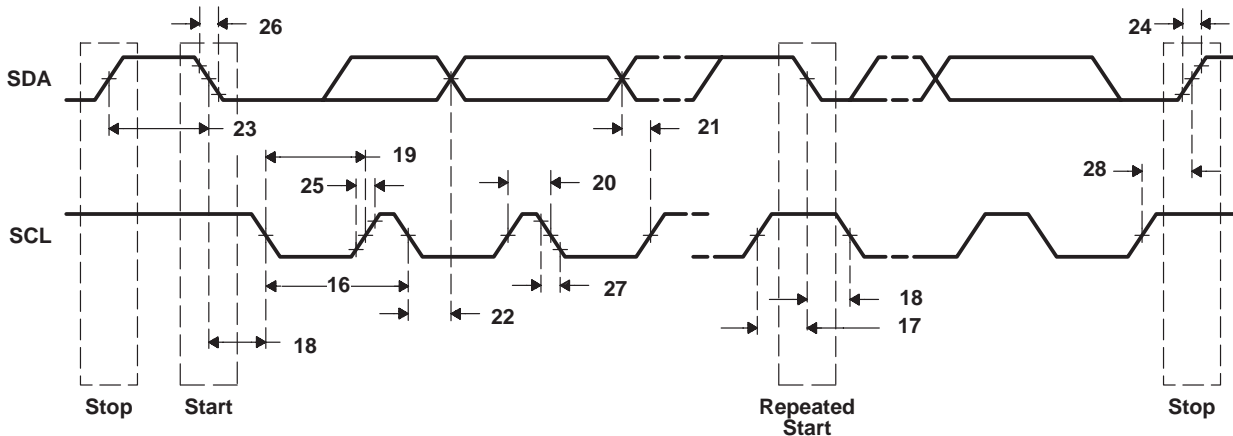

Figure 7–29. I2C Transmit Timings

7.11 Host-Port Interface (HPI) Timing

Table 7–24. Timing Requirements for Host-Port Interface Cycles^{†‡} (see Figure 7–30 through Figure 7–37)

| NO. | | | –500 –600 | | UNIT |
|-----|-----------------------------|--|-----------------|-----|------|
| | | | MIN | MAX | |
| 1 | $t_{su}(\text{SELV-HSTBL})$ | Setup time, select signals [§] valid before $\overline{\text{HSTROBE}}$ low | 5 | | ns |
| 2 | $t_h(\text{HSTBL-SELV})$ | Hold time, select signals [§] valid after $\overline{\text{HSTROBE}}$ low | 2.4 | | ns |
| 3 | $t_w(\text{HSTBL})$ | Pulse duration, $\overline{\text{HSTROBE}}$ low | 4P [¶] | | ns |
| 4 | $t_w(\text{HSTBH})$ | Pulse duration, $\overline{\text{HSTROBE}}$ high between consecutive accesses | 4P | | ns |
| 10 | $t_{su}(\text{SELV-HASL})$ | Setup time, select signals [§] valid before $\overline{\text{HAS}}$ low | 5 | | ns |
| 11 | $t_h(\text{HASL-SELV})$ | Hold time, select signals [§] valid after $\overline{\text{HAS}}$ low | 2 | | ns |
| 12 | $t_{su}(\text{HDV-HSTBH})$ | Setup time, host data valid before $\overline{\text{HSTROBE}}$ high | 5 | | ns |
| 13 | $t_h(\text{HSTBH-HDV})$ | Hold time, host data valid after $\overline{\text{HSTROBE}}$ high | 2.8 | | ns |
| 14 | $t_h(\text{HRDYL-HSTBL})$ | Hold time, $\overline{\text{HSTROBE}}$ low after $\overline{\text{HRDY}}$ low. $\overline{\text{HSTROBE}}$ should not be inactivated until $\overline{\text{HRDY}}$ is active (low); otherwise, HPI writes will not complete properly. | 2 | | ns |
| 18 | $t_{su}(\text{HASL-HSTBL})$ | Setup time, $\overline{\text{HAS}}$ low before $\overline{\text{HSTROBE}}$ low | 2 | | ns |
| 19 | $t_h(\text{HSTBL-HASL})$ | Hold time, $\overline{\text{HAS}}$ low after $\overline{\text{HSTROBE}}$ low | 2.1 | | ns |

[†] $\overline{\text{HSTROBE}}$ refers to the following logical operation on $\overline{\text{HCS}}$, $\overline{\text{HDS1}}$, and $\overline{\text{HDS2}}$: $[\text{NOT}(\overline{\text{HDS1}} \text{ XOR } \overline{\text{HDS2}})] \text{ OR } \overline{\text{HCS}}$.

[‡] P = 1/CPU clock frequency in ns. For example, when running parts at 600 MHz, use P = 1.67 ns.

[§] Select signals include: $\overline{\text{HCNTL}}[1:0]$ and $\overline{\text{HR/W}}$. For HPI16 mode only, select signals also include $\overline{\text{HHWIL}}$.

[¶] Select the parameter value of 4P or 12.5 ns, whichever is larger.

Table 7–25. Switching Characteristics Over Recommended Operating Conditions During Host-Port Interface Cycles^{†‡} (see Figure 7–30 through Figure 7–37)

| NO. | PARAMETER | –500 –600 | | UNIT | |
|-----|----------------------------|---|-----|-----------------------------------|----|
| | | MIN | MAX | | |
| 6 | $t_d(\text{HSTBL-HRDYH})$ | Delay time, $\overline{\text{HSTROBE}}$ low to $\overline{\text{HRDY}}$ high [#] | 1.3 | 4P + 8 | ns |
| 7 | $t_d(\text{HSTBL-HDLZ})$ | Delay time, $\overline{\text{HSTROBE}}$ low to HD low impedance for an HPI read | 2 | | ns |
| 8 | $t_d(\text{HDV-HRDYL})$ | Delay time, HD valid to $\overline{\text{HRDY}}$ low | –3 | | ns |
| 9 | $t_{oh}(\text{HSTBH-HDV})$ | Output hold time, HD valid after $\overline{\text{HSTROBE}}$ high | 1.5 | | ns |
| 15 | $t_d(\text{HSTBH-HDHZ})$ | Delay time, $\overline{\text{HSTROBE}}$ high to HD high impedance | | 12 | ns |
| 16 | $t_d(\text{HSTBL-HDV})$ | Delay time, $\overline{\text{HSTROBE}}$ low to HD valid (HPI16 mode, 2nd half-word only) | | 2P + 8 or 0P + 8 | ns |

[†] $\overline{\text{HSTROBE}}$ refers to the following logical operation on $\overline{\text{HCS}}$, $\overline{\text{HDS1}}$, and $\overline{\text{HDS2}}$: $[\text{NOT}(\overline{\text{HDS1}} \text{ XOR } \overline{\text{HDS2}})] \text{ OR } \overline{\text{HCS}}$.

[‡] P = 1/CPU clock frequency in ns. For example, when running parts at 600 MHz, use P = 1.67 ns.

[#] This parameter is used during HPID reads and writes. For reads, at the beginning of a word transfer (HPI32) or the first half-word transfer (HPI16) on the falling edge of $\overline{\text{HSTROBE}}$, the HPI sends the request to the EDMA internal address generation hardware, and $\overline{\text{HRDY}}$ remains high until the EDMA internal address generation hardware loads the requested data into HPID. For writes, $\overline{\text{HRDY}}$ goes high if the internal write buffer is full.

^{||} If preceding $\overline{\text{HSTROBE}}$ high pulse width > 6P, then this parameter value can be 0P + 8 ns.

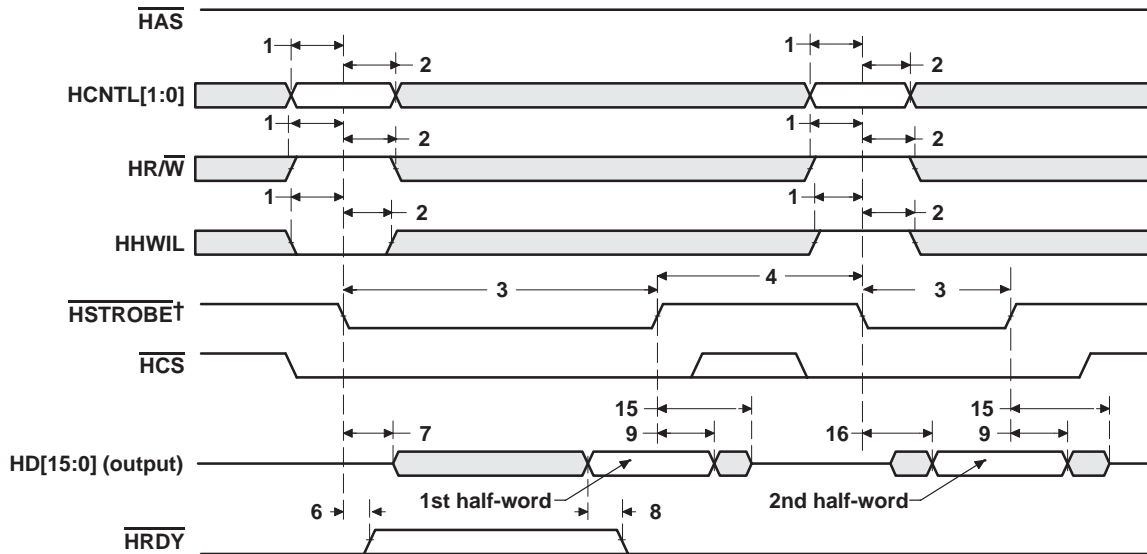

† $\overline{\text{HSTROBE}}$ refers to the following logical operation on $\overline{\text{HCS}}$, $\overline{\text{HDS1}}$, and $\overline{\text{HDS2}}$: $[\text{NOT}(\overline{\text{HDS1}} \text{ XOR } \overline{\text{HDS2}})] \text{ OR } \overline{\text{HCS}}$.

Figure 7–30. HPI16 Read Timing ($\overline{\text{HAS}}$ Not Used, Tied High)

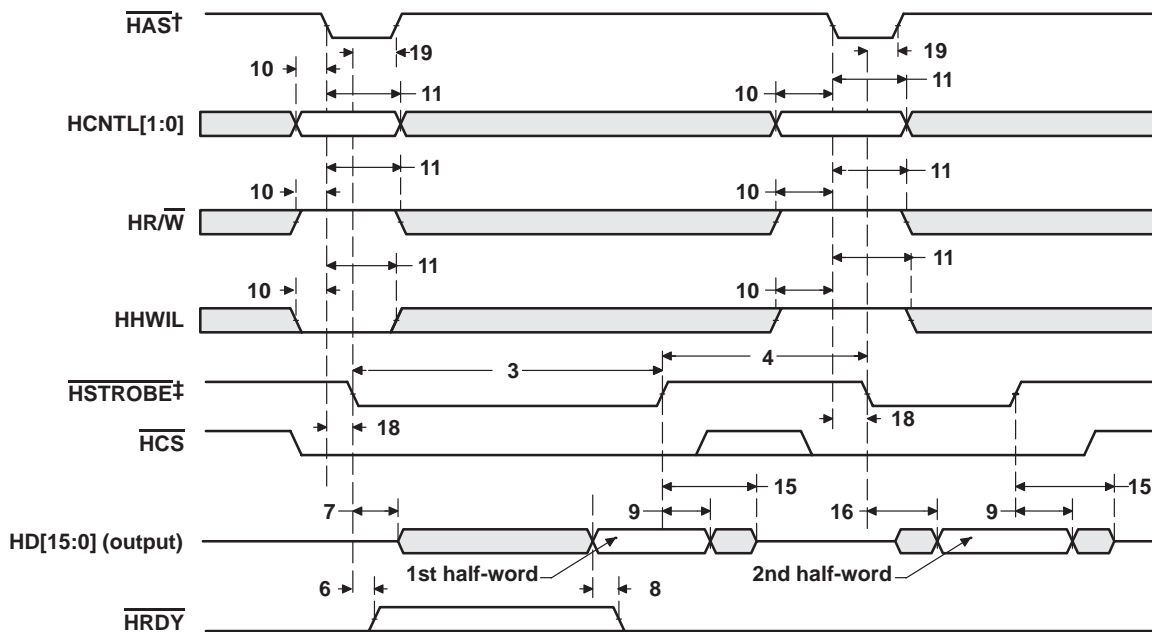

† For correct operation, strobe the $\overline{\text{HAS}}$ signal only once per $\overline{\text{HSTROBE}}$ active cycle.

‡ $\overline{\text{HSTROBE}}$ refers to the following logical operation on $\overline{\text{HCS}}$, $\overline{\text{HDS1}}$, and $\overline{\text{HDS2}}$: $[\text{NOT}(\overline{\text{HDS1}} \text{ XOR } \overline{\text{HDS2}})] \text{ OR } \overline{\text{HCS}}$.

Figure 7–31. HPI16 Read Timing ($\overline{\text{HAS}}$ Used)

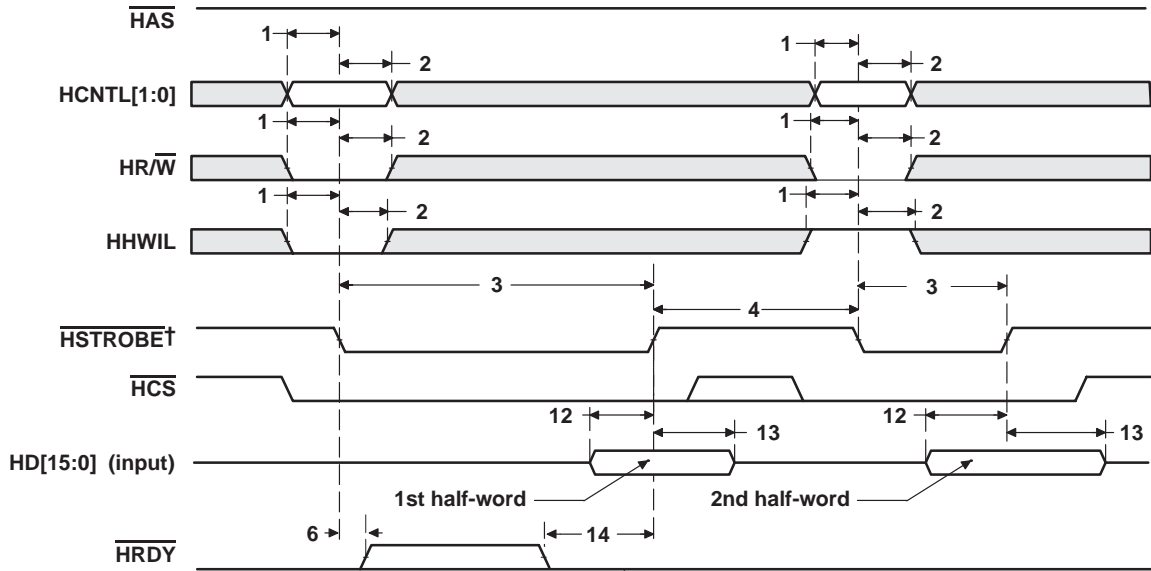

† HSTROBE refers to the following logical operation on $\overline{\text{HCS}}$, $\overline{\text{HDS1}}$, and $\overline{\text{HDS2}}$: $[\text{NOT}(\overline{\text{HDS1}} \text{ XOR } \overline{\text{HDS2}})] \text{ OR } \overline{\text{HCS}}$.

Figure 7–32. HPI16 Write Timing ($\overline{\text{HAS}}$ Not Used, Tied High)

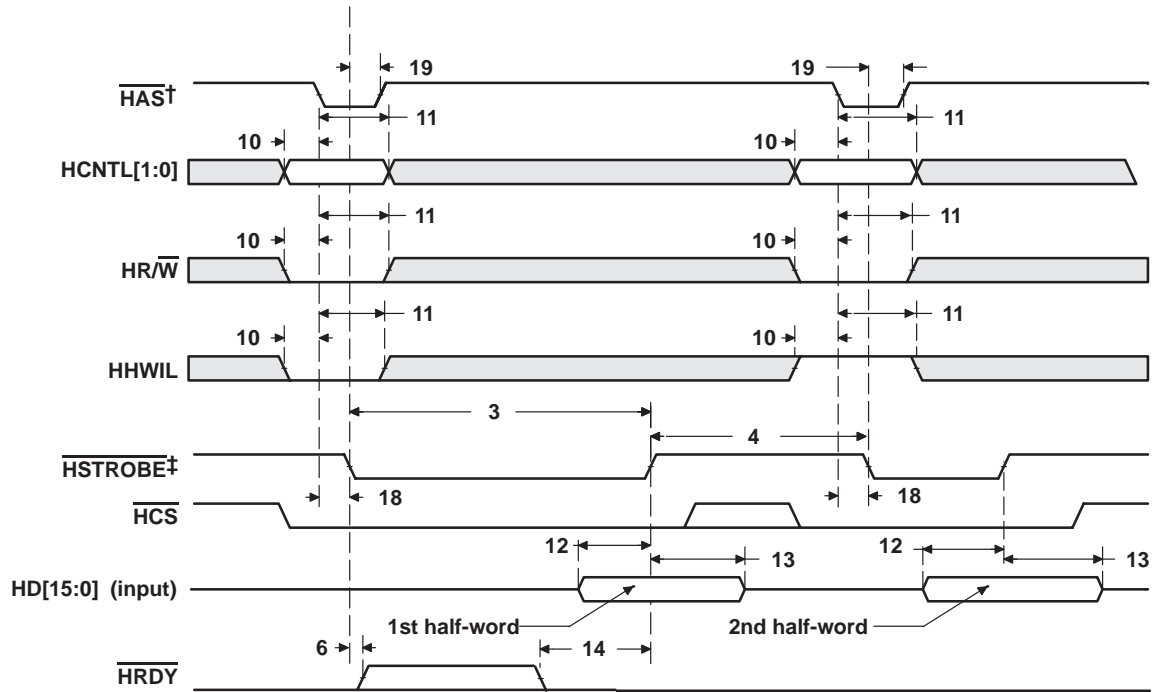

† For correct operation, strobe the $\overline{\text{HAS}}$ signal only once per HSTROBE active cycle.

‡ HSTROBE refers to the following logical operation on $\overline{\text{HCS}}$, $\overline{\text{HDS1}}$, and $\overline{\text{HDS2}}$: $[\text{NOT}(\overline{\text{HDS1}} \text{ XOR } \overline{\text{HDS2}})] \text{ OR } \overline{\text{HCS}}$.

Figure 7–33. HPI16 Write Timing ($\overline{\text{HAS}}$ Used)

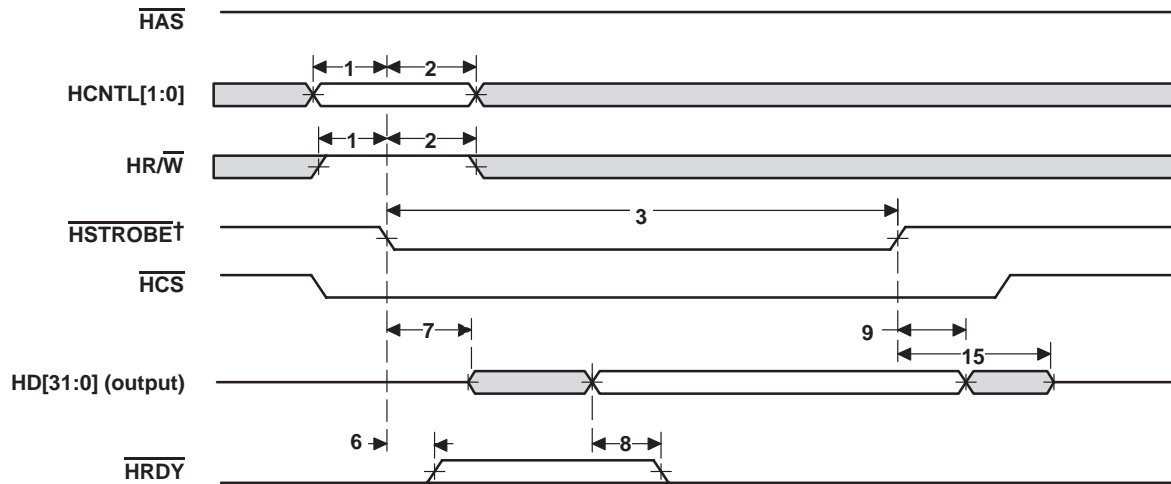

† $\overline{\text{HSTROBE}}$ refers to the following logical operation on $\overline{\text{HCS}}$, $\overline{\text{HDS1}}$, and $\overline{\text{HDS2}}$: $[\text{NOT}(\overline{\text{HDS1}} \text{ XOR } \overline{\text{HDS2}})] \text{ OR } \overline{\text{HCS}}$.

Figure 7–34. HPI32 Read Timing ($\overline{\text{HAS}}$ Not Used, Tied High)

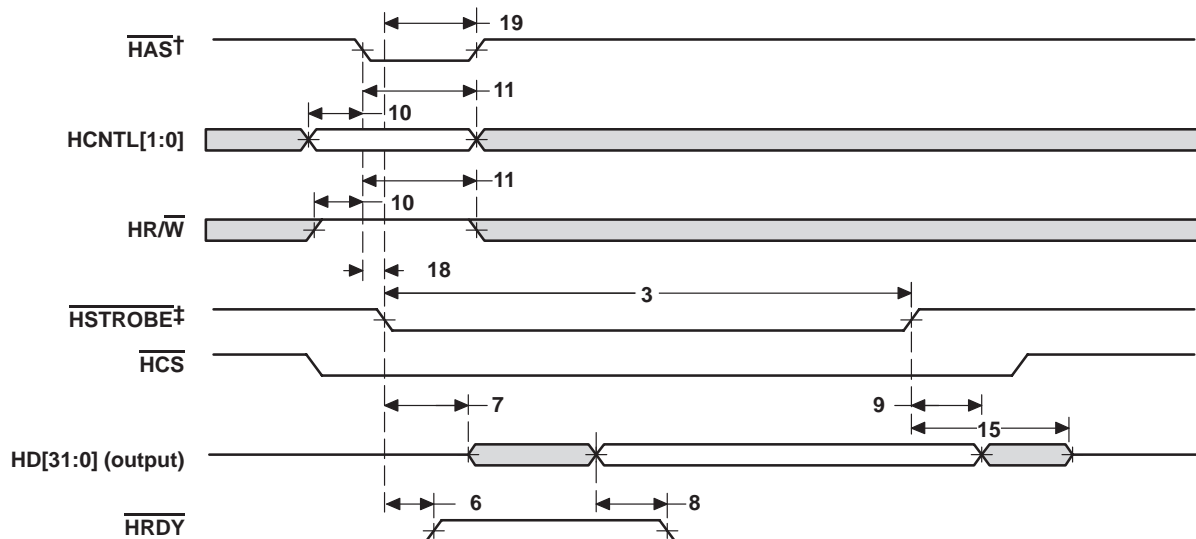

† For correct operation, strobe the $\overline{\text{HAS}}$ signal only once per $\overline{\text{HSTROBE}}$ active cycle.

‡ $\overline{\text{HSTROBE}}$ refers to the following logical operation on $\overline{\text{HCS}}$, $\overline{\text{HDS1}}$, and $\overline{\text{HDS2}}$: $[\text{NOT}(\overline{\text{HDS1}} \text{ XOR } \overline{\text{HDS2}})] \text{ OR } \overline{\text{HCS}}$.

Figure 7–35. HPI32 Read Timing ($\overline{\text{HAS}}$ Used)

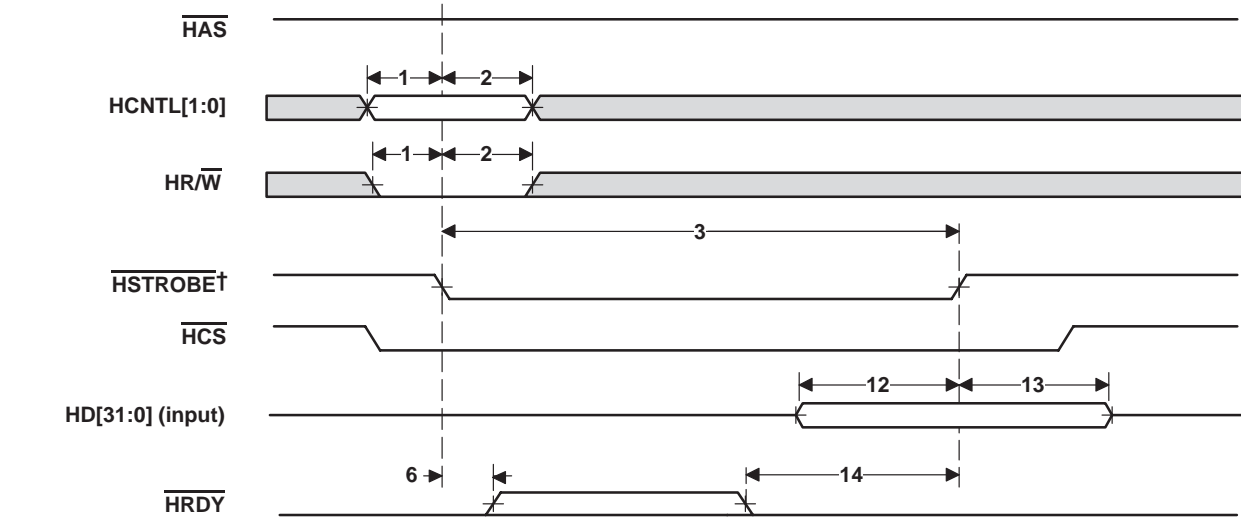

† $\overline{\text{HSTROBE}}$ refers to the following logical operation on $\overline{\text{HCS}}$, $\overline{\text{HDS1}}$, and $\overline{\text{HDS2}}$: $[\text{NOT}(\overline{\text{HDS1}} \text{ XOR } \overline{\text{HDS2}})] \text{ OR } \overline{\text{HCS}}$.

Figure 7–36. HPI32 Write Timing ($\overline{\text{HAS}}$ Not Used, Tied High)

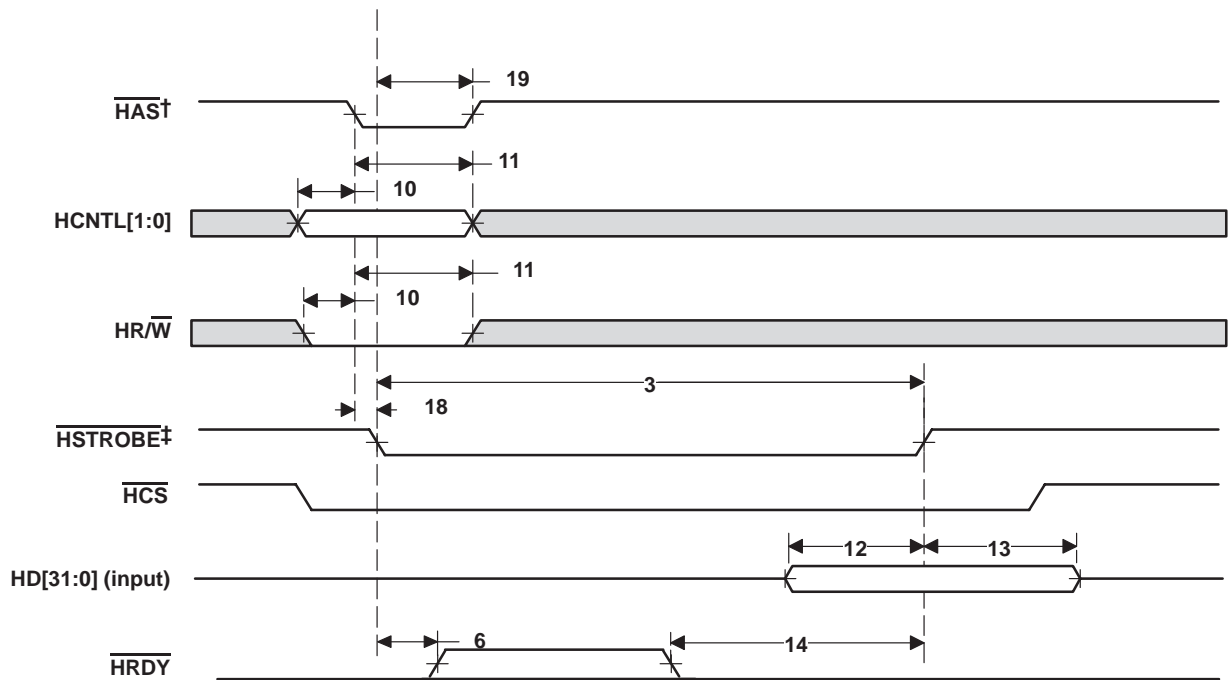

† For correct operation, strobe the $\overline{\text{HAS}}$ signal only once per $\overline{\text{HSTROBE}}$ active cycle.

‡ $\overline{\text{HSTROBE}}$ refers to the following logical operation on $\overline{\text{HCS}}$, $\overline{\text{HDS1}}$, and $\overline{\text{HDS2}}$: $[\text{NOT}(\overline{\text{HDS1}} \text{ XOR } \overline{\text{HDS2}})] \text{ OR } \overline{\text{HCS}}$.

Figure 7–37. HPI32 Write Timing ($\overline{\text{HAS}}$ Used)

7.12 Multichannel Buffered Serial Port (McBSP) Timing

Table 7–26. Timing Requirements for McBSP†‡ (see Figure 7–38)

| NO. | | | -500 -600 | | UNIT |
|-----|---------------------------|---|--------------|----------------------------|------|
| | | | MIN | MAX | |
| 2 | $t_c(\text{CKRX})$ | Cycle time, CLKR/X | CLKR/X ext | 4P or 6.67‡§ | ns |
| 3 | $t_w(\text{CKRX})$ | Pulse duration, CLKR/X high or CLKR/X low | CLKR/X ext | $0.5t_c(\text{CKRX}) - 1¶$ | ns |
| 5 | $t_{su}(\text{FRH-CKRL})$ | Setup time, external FSR high before CLKR low | CLKR int | 9 | ns |
| | | | CLKR ext | 1.3 | |
| 6 | $t_h(\text{CKRL-FRH})$ | Hold time, external FSR high after CLKR low | CLKR int | 6 | ns |
| | | | CLKR ext | 3 | |
| 7 | $t_{su}(\text{DRV-CKRL})$ | Setup time, DR valid before CLKR low | CLKR int | 8 | ns |
| | | | CLKR ext | 0.9 | |
| 8 | $t_h(\text{CKRL-DRV})$ | Hold time, DR valid after CLKR low | CLKR int | 3 | ns |
| | | | CLKR ext | 3.1 | |
| 10 | $t_{su}(\text{FXH-CKXL})$ | Setup time, external FSX high before CLKX low | CLKX int | 9 | ns |
| | | | CLKX ext | 1.3 | |
| 11 | $t_h(\text{CKXL-FXH})$ | Hold time, external FSX high after CLKX low | CLKX int | 6 | ns |
| | | | CLKX ext | 3 | |

† CLKRP = CLKXP = FSRP = FSXP = 0. If polarity of any of the signals is inverted, then the timing references of that signal are also inverted.

‡ P = 1/CPU clock frequency in ns. For example, when running parts at 600 MHz, use P = 1.67 ns.

§ Use whichever value is greater. Minimum CLKR/X cycle times *must* be met, even when CLKR/X is generated by an internal clock source. The minimum CLKR/X cycle times are based on internal logic speed; the maximum usable speed may be lower due to EDMA limitations and AC timing requirements.

¶ This parameter applies to the maximum McBSP frequency. Operate serial clocks (CLKR/X) in the reasonable range of 40/60 duty cycle.

Table 7–27. Switching Characteristics Over Recommended Operating Conditions for McBSP†‡
(see Figure 7–38)

| NO. | PARAMETER | | –500 –600 | | UNIT | |
|-----|-----------------------------|--|--------------|---------------|-----------|----|
| | | | MIN | MAX | | |
| 1 | $t_d(\text{CKSH-CKRXH})$ | Delay time, CLKS high to CLKR/X high for internal CLKR/X generated from CLKS input | 1.4 | 10 | ns | |
| 2 | $t_c(\text{CKRX})$ | Cycle time, CLKR/X | CLKR/X int | 4P or 6.67S¶# | ns | |
| 3 | $t_w(\text{CKRX})$ | Pulse duration, CLKR/X high or CLKR/X low | CLKR/X int | C – 1 C + 1 | ns | |
| 4 | $t_d(\text{CKRH-FRV})$ | Delay time, CLKR high to internal FSR valid | CLKR int | –2.1 | 3 | ns |
| 9 | $t_d(\text{CKXH-FXV})$ | Delay time, CLKX high to internal FSX valid | CLKX int | –1.7 | 3 | ns |
| | | | CLKX ext | 1.7 | 9 | |
| 12 | $t_{dis}(\text{CKXH-DXHZ})$ | Disable time, DX high impedance following last data bit from CLKX high | CLKX int | –3.9 | 4 | ns |
| | | | CLKX ext | 2 | 9 | |
| 13 | $t_d(\text{CKXH-DXV})$ | Delay time, CLKX high to DX valid | CLKX int | –3.9 + D1★ | 4 + D2★ | ns |
| | | | CLKX ext | 2.0 + D1★ | 9 + D2★ | |
| 14 | $t_d(\text{FXH-DXV})$ | Delay time, FSX high to DX valid | FSX int | –2.3 + D1□ | 5.6 + D2□ | ns |
| | | ONLY applies when in data delay 0 (XDATDLY = 00b) mode | FSX ext | 1.9 + D1□ | 9 + D2□ | |

† CLKRP = CLKXP = FSRP = FSXP = 0. If polarity of any of the signals is inverted, then the timing references of that signal are also inverted.

‡ Minimum delay times also represent minimum output hold times.

§ Minimum CLKR/X cycle times must be met, even when CLKR/X is generated by an internal clock source. Minimum CLKR/X cycle times are based on internal logic speed; the maximum usable speed may be lower due to EDMA limitations and AC timing requirements.

¶ P = 1/CPU clock frequency in ns. For example, when running parts at 600 MHz, use P = 1.67 ns.

Use whichever value is greater.

|| C = H or L

S = sample rate generator input clock = 4P if CLKSM = 1 (P = 1/CPU clock frequency)

= sample rate generator input clock = P_clks if CLKSM = 0 (P_clks = CLKS period)

H = CLKX high pulse width = (CLKGDV/2 + 1) * S if CLKGDV is even

= (CLKGDV + 1)/2 * S if CLKGDV is odd or zero

L = CLKX low pulse width = (CLKGDV/2) * S if CLKGDV is even

= (CLKGDV + 1)/2 * S if CLKGDV is odd or zero

CLKGDV should be set appropriately to ensure the McBSP bit rate does not exceed the maximum limit (see ¶ footnote above).

★ Extra delay from CLKX high to DX valid **applies only to the first data bit of a device**, if and only if DXENA = 1 in SPCR.

if DXENA = 0, then D1 = D2 = 0

if DXENA = 1, then D1 = 4P, D2 = 8P

□ Extra delay from FSX high to DX valid **applies only to the first data bit of a device**, if and only if DXENA = 1 in SPCR.

if DXENA = 0, then D1 = D2 = 0

if DXENA = 1, then D1 = 4P, D2 = 8P

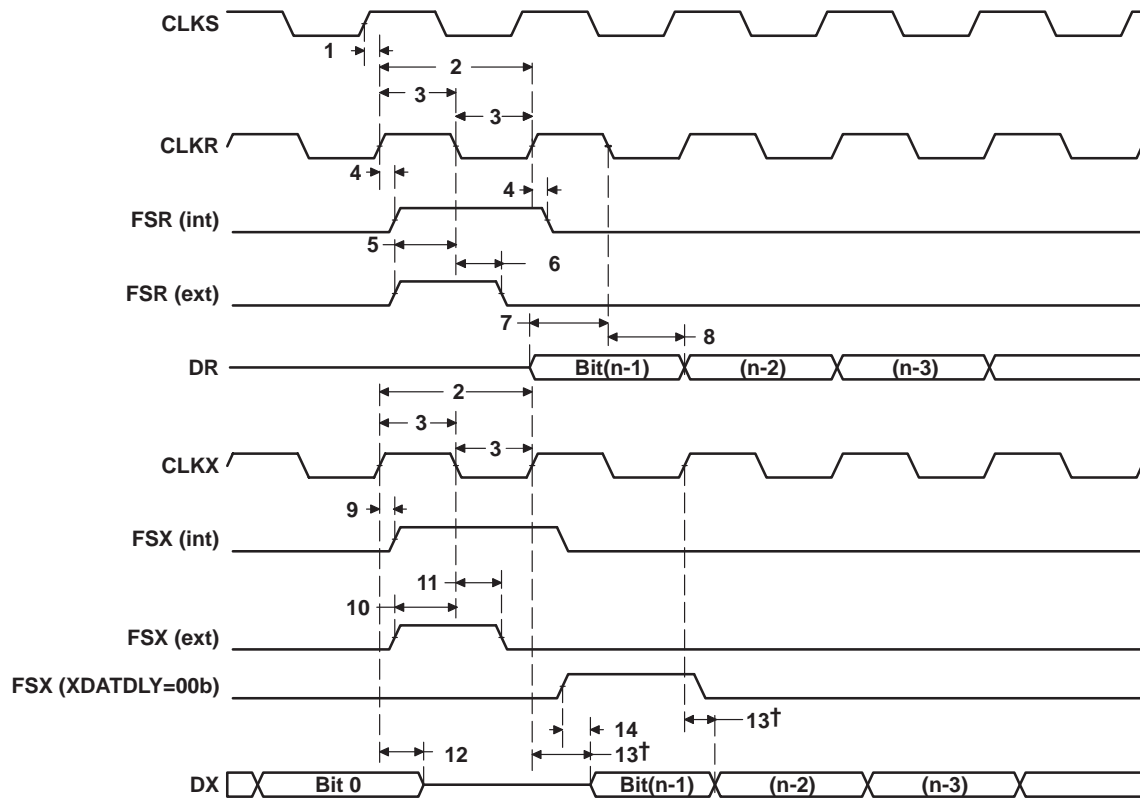

† Parameter No. 13 applies to the first data bit *only* when XDATDLY ≠ 0

Figure 7–38. McBSP Timing

Table 7–28. Timing Requirements for FSR When GSYNC = 1 (see Figure 7–39)

| NO. | | –500 –600 | | UNIT |
|-----|--|--------------|-----|------|
| | | MIN | MAX | |
| 1 | $t_{su}(FRH-CKSH)$ Setup time, FSR high before CLKS high | 4 | | ns |
| 2 | $t_h(CKSH-FRH)$ Hold time, FSR high after CLKS high | 4 | | ns |

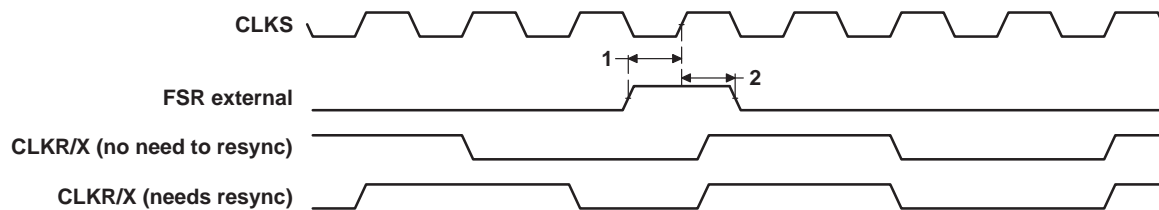

Figure 7–39. FSR Timing When GSYNC = 1

**Table 7–29. Timing Requirements for McBSP as SPI Master or Slave:
CLKSTP = 10b, CLKXP = 0†‡ (see Figure 7–40)**

| NO. | | -500 -600 | | | | UNIT |
|-----|---|--------------|-----|---------|-----|------|
| | | MASTER | | SLAVE | | |
| | | MIN | MAX | MIN | MAX | |
| 4 | $t_{su}(DRV-CKXL)$ Setup time, DR valid before CLKX low | 12 | | 2 – 12P | ns | |
| 5 | $t_h(CKXL-DRV)$ Hold time, DR valid after CLKX low | 4 | | 5 + 24P | ns | |

† P = 1/CPU clock frequency in ns. For example, when running parts at 600 MHz, use P = 1.67 ns.

‡ For all SPI Slave modes, CLKG is programmed as 1/4 of the CPU clock by setting CLKSM = CLKGDV = 1.

**Table 7–30. Switching Characteristics Over Recommended Operating Conditions for McBSP as
SPI Master or Slave: CLKSTP = 10b, CLKXP = 0†‡ (see Figure 7–40)**

| NO. | PARAMETER | -500 -600 | | | | UNIT |
|-----|--|--------------|-------|-----------|----------|------|
| | | MASTER§ | | SLAVE | | |
| | | MIN | MAX | MIN | MAX | |
| 1 | $t_h(CKXL-FXL)$ Hold time, FSX low after CLKX low¶ | T – 2 | T + 3 | | | ns |
| 2 | $t_d(FXL-CKXH)$ Delay time, FSX low to CLKX high# | L – 2 | L + 3 | | | ns |
| 3 | $t_d(CKXH-DXV)$ Delay time, CLKX high to DX valid | –2 | 4 | 12P + 2.8 | 20P + 17 | ns |
| 6 | $t_{dis}(CKXL-DXHZ)$ Disable time, DX high impedance following last data bit from CLKX low | L – 2 | L + 3 | | | ns |
| 7 | $t_{dis}(FXH-DXHZ)$ Disable time, DX high impedance following last data bit from FSX high | | | 4P + 3 | 12P + 17 | ns |
| 8 | $t_d(FXL-DXV)$ Delay time, FSX low to DX valid | | | 8P + 1.8 | 16P + 17 | ns |

† P = 1/CPU clock frequency in ns. For example, when running parts at 600 MHz, use P = 1.67 ns.

‡ For all SPI Slave modes, CLKG is programmed as 1/4 of the CPU clock by setting CLKSM = CLKGDV = 1.

§ S = Sample rate generator input clock = 4P if CLKSM = 1 (P = 1/CPU clock frequency)

= Sample rate generator input clock = P_clks if CLKSM = 0 (P_clks = CLKX period)

T = CLKX period = (1 + CLKGDV) * S

H = CLKX high pulse width = (CLKGDV/2 + 1) * S if CLKGDV is even

= (CLKGDV + 1)/2 * S if CLKGDV is odd or zero

L = CLKX low pulse width = (CLKGDV/2) * S if CLKGDV is even

= (CLKGDV + 1)/2 * S if CLKGDV is odd or zero

¶ FSRP = FSXP = 1. As a SPI Master, FSX is inverted to provide active-low slave-enable output. As a Slave, the active-low signal input on FSX and FSR is inverted before being used internally.

CLKXM = FSXM = 1, CLKRM = FSRM = 0 for Master McBSP

CLKXM = CLKRM = FSXM = FSRM = 0 for Slave McBSP

FSX should be low before the rising edge of clock to enable Slave devices and then begin a SPI transfer at the rising edge of the Master clock (CLKX).

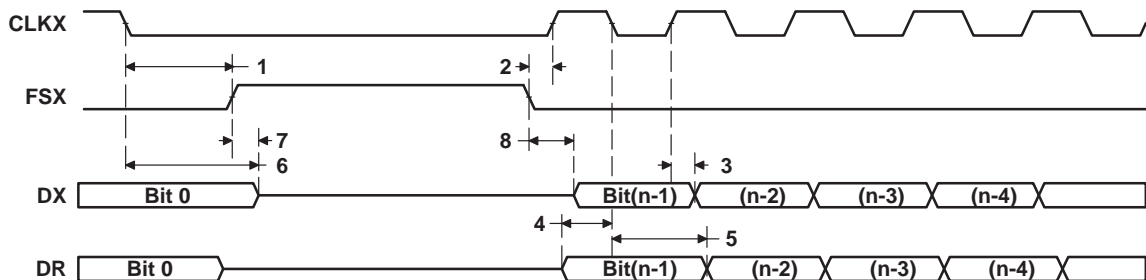

Figure 7–40. McBSP Timing as SPI Master or Slave: CLKSTP = 10b, CLKXP = 0

**Table 7–31. Timing Requirements for McBSP as SPI Master or Slave:
CLKSTP = 11b, CLKXP = 0†‡ (see Figure 7–41)**

| NO. | | -500 -600 | | | | UNIT |
|-----|--|--------------|-----|---------|-----|------|
| | | MASTER | | SLAVE | | |
| | | MIN | MAX | MIN | MAX | |
| 4 | $t_{su}(DRV-CKXH)$ Setup time, DR valid before CLKX high | 12 | | 2 – 12P | ns | |
| 5 | $t_h(CKXH-DRV)$ Hold time, DR valid after CLKX high | 4 | | 5 + 24P | ns | |

† P = 1/CPU clock frequency in ns. For example, when running parts at 600 MHz, use P = 1.67 ns.

‡ For all SPI Slave modes, CLKX is programmed as 1/4 of the CPU clock by setting CLKSM = CLKGDV = 1.

**Table 7–32. Switching Characteristics Over Recommended Operating Conditions for McBSP as
SPI Master or Slave: CLKSTP = 11b, CLKXP = 0†‡ (see Figure 7–41)**

| NO. | PARAMETER | -500 -600 | | | | UNIT |
|-----|--|--------------|-------|-----------|----------|------|
| | | MASTER§ | | SLAVE | | |
| | | MIN | MAX | MIN | MAX | |
| 1 | $t_h(CKXL-FXL)$ Hold time, FSX low after CLKX low¶ | L – 2 | L + 3 | | | ns |
| 2 | $t_d(FXL-CKXH)$ Delay time, FSX low to CLKX high# | T – 2 | T + 3 | | | ns |
| 3 | $t_d(CKXL-DXV)$ Delay time, CLKX low to DX valid | -2 | 4 | 12P + 2.8 | 20P + 17 | ns |
| 6 | $t_{dis}(CKXL-DXHZ)$ Disable time, DX high impedance following last data bit from CLKX low | -2 | 4 | 12P + 3 | 20P + 17 | ns |
| 7 | $t_d(FXL-DXV)$ Delay time, FSX low to DX valid | H – 2 | H + 4 | 8P + 2 | 16P + 17 | ns |

† P = 1/CPU clock frequency in ns. For example, when running parts at 600 MHz, use P = 1.67 ns.

‡ For all SPI Slave modes, CLKX is programmed as 1/4 of the CPU clock by setting CLKSM = CLKGDV = 1.

§ S = Sample rate generator input clock = 4P if CLKSM = 1 (P = 1/CPU clock frequency)

= Sample rate generator input clock = P_clks if CLKSM = 0 (P_clks = CLKX period)

T = CLKX period = (1 + CLKGDV) * S

H = CLKX high pulse width = (CLKGDV/2 + 1) * S if CLKGDV is even
= (CLKGDV + 1)/2 * S if CLKGDV is odd or zero

L = CLKX low pulse width = (CLKGDV/2) * S if CLKGDV is even
= (CLKGDV + 1)/2 * S if CLKGDV is odd or zero

¶ FSRP = FSXP = 1. As a SPI Master, FSX is inverted to provide active-low slave-enable output. As a Slave, the active-low signal input on FSX and FSR is inverted before being used internally.

CLKXM = FSXM = 1, CLKRM = FSRM = 0 for Master McBSP

CLKXM = CLKRM = FSXM = FSRM = 0 for Slave McBSP

FSX should be low before the rising edge of clock to enable Slave devices and then begin a SPI transfer at the rising edge of the Master clock (CLKX).

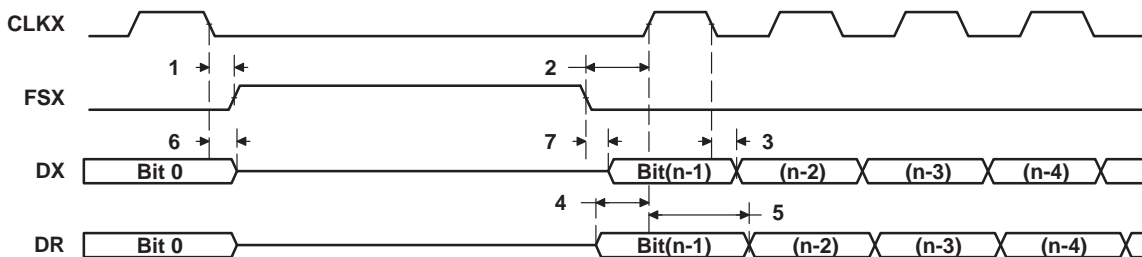

Figure 7–41. McBSP Timing as SPI Master or Slave: CLKSTP = 11b, CLKXP = 0

**Table 7–33. Timing Requirements for McBSP as SPI Master or Slave:
CLKSTP = 10b, CLKXP = 1†‡ (see Figure 7–42)**

| NO. | | -500 -600 | | | | UNIT |
|-----|--|--------------|-----|---------|-----|------|
| | | MASTER | | SLAVE | | |
| | | MIN | MAX | MIN | MAX | |
| 4 | $t_{su}(DRV-CKXH)$ Setup time, DR valid before CLKX high | 12 | | 2 – 12P | ns | |
| 5 | $t_h(CKXH-DRV)$ Hold time, DR valid after CLKX high | 4 | | 5 + 24P | ns | |

† P = 1/CPU clock frequency in ns. For example, when running parts at 600 MHz, use P = 1.67 ns.

‡ For all SPI Slave modes, CLKG is programmed as 1/4 of the CPU clock by setting CLKSM = CLKGDV = 1.

**Table 7–34. Switching Characteristics Over Recommended Operating Conditions for McBSP as
SPI Master or Slave: CLKSTP = 10b, CLKXP = 1†‡ (see Figure 7–42)**

| NO. | PARAMETER | -500 -600 | | | | UNIT |
|-----|---|--------------|-------|-----------|----------|------|
| | | MASTER§ | | SLAVE | | |
| | | MIN | MAX | MIN | MAX | |
| 1 | $t_h(CKXH-FXL)$ Hold time, FSX low after CLKX high¶ | T – 2 | T + 3 | | | ns |
| 2 | $t_d(FXL-CKXL)$ Delay time, FSX low to CLKX low# | H – 2 | H + 3 | | | ns |
| 3 | $t_d(CKXL-DXV)$ Delay time, CLKX low to DX valid | –2 | 4 | 12P + 2.8 | 20P + 17 | ns |
| 6 | $t_{dis}(CKXH-DXHZ)$ Disable time, DX high impedance following last data bit from CLKX high | H – 2 | H + 3 | | | ns |
| 7 | $t_{dis}(FXH-DXHZ)$ Disable time, DX high impedance following last data bit from FSX high | | | 4P + 3 | 12P + 17 | ns |
| 8 | $t_d(FXL-DXV)$ Delay time, FSX low to DX valid | | | 8P + 2 | 16P + 17 | ns |

† P = 1/CPU clock frequency in ns. For example, when running parts at 600 MHz, use P = 1.67 ns.

‡ For all SPI Slave modes, CLKG is programmed as 1/4 of the CPU clock by setting CLKSM = CLKGDV = 1.

§ S = Sample rate generator input clock = 4P if CLKSM = 1 (P = 1/CPU clock frequency)

= Sample rate generator input clock = P_clks if CLKSM = 0 (P_clks = CLKS period)

T = CLKX period = (1 + CLKGDV) * S

H = CLKX high pulse width = (CLKGDV/2 + 1) * S if CLKGDV is even
= (CLKGDV + 1)/2 * S if CLKGDV is odd or zero

L = CLKX low pulse width = (CLKGDV/2) * S if CLKGDV is even
= (CLKGDV + 1)/2 * S if CLKGDV is odd or zero

¶ FSRP = FSXP = 1. As a SPI Master, FSX is inverted to provide active-low slave-enable output. As a Slave, the active-low signal input on FSX and FSR is inverted before being used internally.

CLKXM = FSXM = 1, CLKRM = FSRM = 0 for Master McBSP

CLKXM = CLKRM = FSXM = FSRM = 0 for Slave McBSP

FSX should be low before the rising edge of clock to enable Slave devices and then begin a SPI transfer at the rising edge of the Master clock (CLKX).

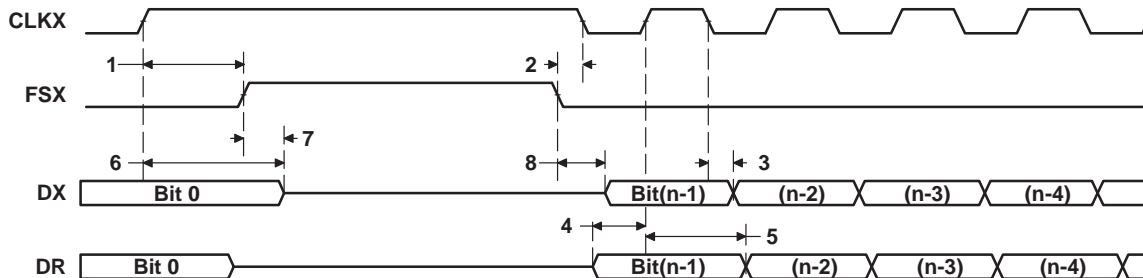

Figure 7–42. McBSP Timing as SPI Master or Slave: CLKSTP = 10b, CLKXP = 1

**Table 7–35. Timing Requirements for McBSP as SPI Master or Slave:
CLKSTP = 11b, CLKXP = 1†‡ (see Figure 7–43)**

| NO. | | -500 -600 | | | | UNIT |
|-----|--|--------------|-----|---------|-----|------|
| | | MASTER | | SLAVE | | |
| | | MIN | MAX | MIN | MAX | |
| 4 | $t_{su}(DRV-CKXH)$ Setup time, DR valid before CLKX high | 12 | | 2 – 12P | ns | |
| 5 | $t_h(CKXH-DRV)$ Hold time, DR valid after CLKX high | 4 | | 5 + 24P | ns | |

† P = 1/CPU clock frequency in ns. For example, when running parts at 600 MHz, use P = 1.67 ns.

‡ For all SPI Slave modes, CLKG is programmed as 1/4 of the CPU clock by setting CLKSM = CLKGDV = 1.

**Table 7–36. Switching Characteristics Over Recommended Operating Conditions for McBSP as
SPI Master or Slave: CLKSTP = 11b, CLKXP = 1†‡ (see Figure 7–43)**

| NO. | PARAMETER | -500 -600 | | | | UNIT |
|-----|---|--------------|-------|-----------|----------|------|
| | | MASTER§ | | SLAVE | | |
| | | MIN | MAX | MIN | MAX | |
| 1 | $t_h(CKXH-FXL)$ Hold time, FSX low after CLKX high¶ | H – 2 | H + 3 | | | ns |
| 2 | $t_d(FXL-CKXL)$ Delay time, FSX low to CLKX low# | T – 2 | T + 1 | | | ns |
| 3 | $t_d(CKXH-DXV)$ Delay time, CLKX high to DX valid | –2 | 4 | 12P + 2.8 | 20P + 17 | ns |
| 6 | $t_{dis}(CKXH-DXHZ)$ Disable time, DX high impedance following last data bit from CLKX high | –2 | 4 | 12P + 3 | 20P + 17 | ns |
| 7 | $t_d(FXL-DXV)$ Delay time, FSX low to DX valid | L – 2 | L + 4 | 8P + 2 | 16P + 17 | ns |

† P = 1/CPU clock frequency in ns. For example, when running parts at 600 MHz, use P = 1.67 ns.

‡ For all SPI Slave modes, CLKG is programmed as 1/4 of the CPU clock by setting CLKSM = CLKGDV = 1.

§ S = Sample rate generator input clock = 4P if CLKSM = 1 (P = 1/CPU clock frequency)

= Sample rate generator input clock = P_clks if CLKSM = 0 (P_clks = CLKX period)

T = CLKX period = (1 + CLKGDV) * S

H = CLKX high pulse width = (CLKGDV/2 + 1) * S if CLKGDV is even
= (CLKGDV + 1)/2 * S if CLKGDV is odd or zero

L = CLKX low pulse width = (CLKGDV/2) * S if CLKGDV is even
= (CLKGDV + 1)/2 * S if CLKGDV is odd or zero

¶ FSRP = FSXP = 1. As a SPI Master, FSX is inverted to provide active-low slave-enable output. As a Slave, the active-low signal input on FSX and FSR is inverted before being used internally.

CLKXM = FSXM = 1, CLKRM = FSRM = 0 for Master McBSP

CLKXM = CLKRM = FSXM = FSRM = 0 for Slave McBSP

FSX should be low before the rising edge of clock to enable Slave devices and then begin a SPI transfer at the rising edge of the Master clock (CLKX).

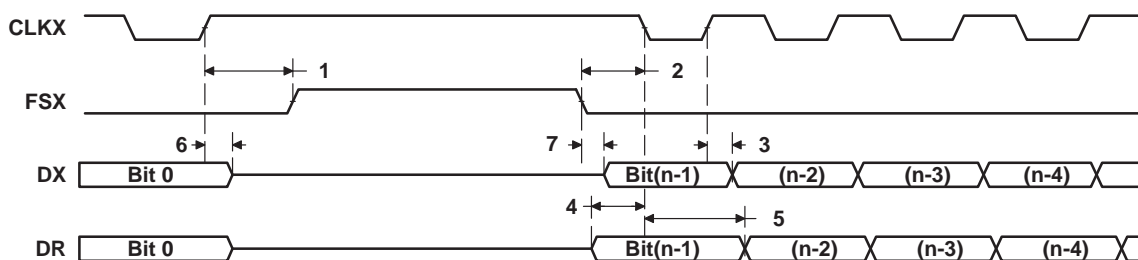

Figure 7–43. McBSP Timing as SPI Master or Slave: CLKSTP = 11b, CLKXP = 1

7.13 Timer Timing

Table 7-37. Timing Requirements for Timer Inputs[†] (see Figure 7-44)

| NO. | | -500 -600 | | UNIT |
|-----|---|--------------|-----|------|
| | | MIN | MAX | |
| 1 | $t_w(\text{TINPH})$ Pulse duration, TINP high | 8P | | ns |
| 2 | $t_w(\text{TINPL})$ Pulse duration, TINP low | 8P | | ns |

[†] P = 1/CPU clock frequency in ns. For example, when running parts at 600 MHz, use P = 1.67 ns.

Table 7-38. Switching Characteristics Over Recommended Operating Conditions for Timer Outputs[†] (see Figure 7-44)

| NO. | PARAMETER | -500 -600 | | UNIT |
|-----|---|--------------|-----|------|
| | | MIN | MAX | |
| 3 | $t_w(\text{TOUTH})$ Pulse duration, TOUT high | 8P-3 | | ns |
| 4 | $t_w(\text{TOUPL})$ Pulse duration, TOUT low | 8P-3 | | ns |

[†] P = 1/CPU clock frequency in ns. For example, when running parts at 600 MHz, use P = 1.67 ns.

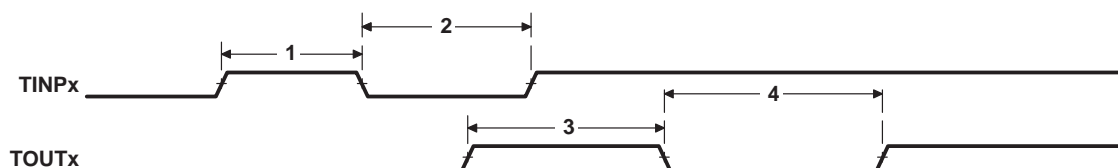

Figure 7-44. Timer Timing

7.14 General-Purpose Input/Output (GPIO) Port Timing

Table 7–39. Timing Requirements for GPIO Inputs†‡ (see Figure 7–45)

| NO. | | –500 –600 | | UNIT |
|-----|--|--------------|-----|------|
| | | MIN | MAX | |
| 1 | $t_w(\text{GPIH})$ Pulse duration, GPIx high | 8P | | ns |
| 2 | $t_w(\text{GPIL})$ Pulse duration, GPIx low | 8P | | ns |

† P = 1/CPU clock frequency in ns. For example, when running parts at 600 MHz, use P = 1.67 ns.

‡ The pulse width given is sufficient to generate a CPU interrupt or an EDMA event. However, if a user wants to have the DSP recognize the GPIx changes through software polling of the GPIO register, the GPIx duration must be extended to at least 12P to allow the DSP enough time to access the GPIO register through the CFGBUS.

Table 7–40. Switching Characteristics Over Recommended Operating Conditions for GPIO Outputs† (see Figure 7–45)

| NO. | PARAMETER | –500 –600 | | UNIT |
|-----|--|--------------|-----|------|
| | | MIN | MAX | |
| 3 | $t_w(\text{GPOH})$ Pulse duration, GPOx high | 24P – 8§ | | ns |
| 4 | $t_w(\text{GPOL})$ Pulse duration, GPOx low | 24P – 8§ | | ns |

† P = 1/CPU clock frequency in ns. For example, when running parts at 600 MHz, use P = 1.67 ns.

§ This parameter value should not be used as a maximum performance specification. Actual performance of back-to-back accesses of the GPIO is dependent upon internal bus activity.

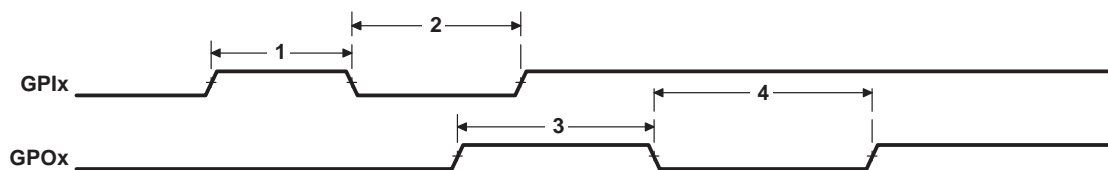

Figure 7–45. GPIO Port Timing

7.15 JTAG Test-Port Timing

Table 7–41. Timing Requirements for JTAG Test Port (see Figure 7–46)

| NO. | | -500 -600 | | UNIT |
|-----|--|--------------|-----|------|
| | | MIN | MAX | |
| 1 | $t_c(\text{TCK})$ Cycle time, TCK | 35 | | ns |
| 3 | $t_{su}(\text{TDIV-TCKH})$ Setup time, TDI/TMS/ $\overline{\text{TRST}}$ valid before TCK high | 10 | | ns |
| 4 | $t_h(\text{TCKH-TDIV})$ Hold time, TDI/TMS/ $\overline{\text{TRST}}$ valid after TCK high | 9 | | ns |

Table 7–42. Switching Characteristics Over Recommended Operating Conditions for JTAG Test Port (see Figure 7–46)

| NO. | PARAMETER | -500 -600 | | UNIT |
|-----|--|--------------|-----|------|
| | | MIN | MAX | |
| 2 | $t_d(\text{TCKL-TDOV})$ Delay time, TCK low to TDO valid | 0 | 18 | ns |

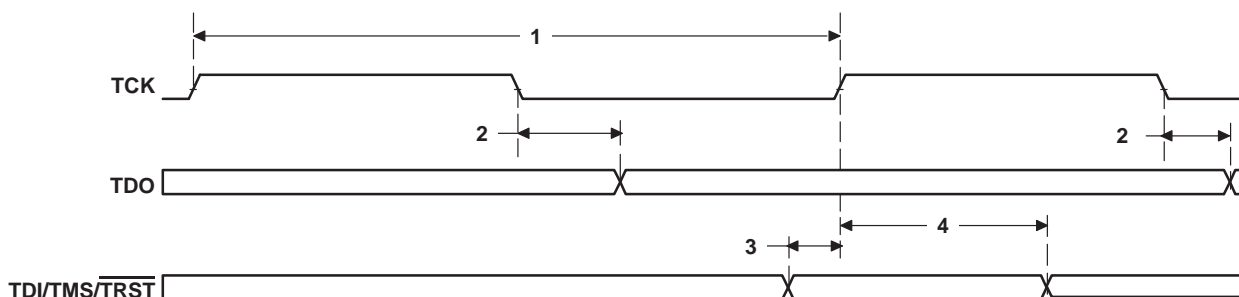

Figure 7–46. JTAG Test-Port Timing

8 Mechanical Data

8.1 Thermal Data

The following tables show the thermal resistance characteristics for the PBGA – GTS and ZTS mechanical packages.

Table 8–1. Thermal Resistance Characteristics (S-PBGA Package) [GTS]

| NO. | | °C/W | Board Type† | Air Flow (m/s‡) |
|-----|---|------|------------------------|-----------------|
| 1 | R θ _{JC} Junction-to-case | 5.60 | JEDEC Low-K Test Card | N/A |
| 2 | R θ _{JB} Junction-to-board | 9.37 | JEDEC High-K Test Card | N/A |
| 3 | R θ _{JA} Junction-to-free air | 20.8 | JEDEC High-K Test Card | 0.00 |
| 4 | | 16.8 | JEDEC High-K Test Card | 0.5 |
| 5 | | 15.4 | JEDEC High-K Test Card | 1.0 |
| 6 | | 14.1 | JEDEC High-K Test Card | 2.00 |
| 7 | Psi _{JT} Junction-to-package top | 1.87 | JEDEC High-K Test Card | 0.00 |
| | | 1.98 | JEDEC High-K Test Card | 0.5 |
| | | 2.03 | JEDEC High-K Test Card | 1.0 |
| | | 2.12 | JEDEC High-K Test Card | 2.00 |
| 8 | Psi _{JB} Junction-to-board | 11.1 | JEDEC High-K Test Card | 0.00 |
| | | 10.4 | JEDEC High-K Test Card | 0.5 |
| | | 10.3 | JEDEC High-K Test Card | 1.0 |
| | | 10.1 | JEDEC High-K Test Card | 2.00 |

† Board types are as defined by JEDEC. Reference JEDEC Standard JESD51–9. Test Boards for Area Array Surface Mount Package Thermal Measurements.

‡ m/s = meters per second

Table 8–2. Thermal Resistance Characteristics (S-PBGA Package) [ZTS]

| NO. | | °C/W | Board Type† | Air Flow (m/s‡) |
|-----|---|------|------------------------|-----------------|
| 1 | R θ _{JC} Junction-to-case | 5.60 | JEDEC Low-K Test Card | N/A |
| 2 | R θ _{JB} Junction-to-board | 9.37 | JEDEC High-K Test Card | N/A |
| 3 | R θ _{JA} Junction-to-free air | 20.8 | JEDEC High-K Test Card | 0.00 |
| 4 | | 16.8 | JEDEC High-K Test Card | 0.5 |
| 5 | | 15.4 | JEDEC High-K Test Card | 1.0 |
| 6 | | 14.1 | JEDEC High-K Test Card | 2.00 |
| 7 | Psi _{JT} Junction-to-package top | 1.87 | JEDEC High-K Test Card | 0.00 |
| | | 1.98 | JEDEC High-K Test Card | 0.5 |
| | | 2.03 | JEDEC High-K Test Card | 1.0 |
| | | 2.12 | JEDEC High-K Test Card | 2.00 |
| 8 | Psi _{JB} Junction-to-board | 11.1 | JEDEC High-K Test Card | 0.00 |
| | | 10.4 | JEDEC High-K Test Card | 0.5 |
| | | 10.3 | JEDEC High-K Test Card | 1.0 |
| | | 10.1 | JEDEC High-K Test Card | 2.00 |

† Board types are as defined by JEDEC. Reference JEDEC Standard JESD51–9. Test Boards for Area Array Surface Mount Package Thermal Measurements.

‡ m/s = meters per second

8.2 Packaging Information

The following packaging information reflects the most current released data available for the designated device(s). This data is subject to change without notice and without revision of this document.

PACKAGING INFORMATION

| Orderable part number | Status (1) | Material type (2) | Package Pins | Package qty Carrier | RoHS (3) | Lead finish/ Ball material (4) | MSL rating/ Peak reflow (5) | Op temp (°C) | Part marking (6) |
|------------------------------------|---------------|----------------------|-------------------|-----------------------|-------------|--------------------------------------|-----------------------------------|--------------|----------------------------|
| TMS320C6418GTSA500 | Active | Production | FCBGA (GTS) 288 | 60 JEDEC TRAY (5+1) | No | SNPB | Level-4-220C-72 HR | -40 to 105 | TMS 320C6418 GTSA500 |
| TMS320C6418GTSA500.A | Active | Production | FCBGA (GTS) 288 | 60 JEDEC TRAY (5+1) | No | SNPB | Level-4-220C-72 HR | -40 to 105 | TMS 320C6418 GTSA500 |
| TMS320C6418ZTS600 | Active | Production | FCBGA (ZTS) 288 | 60 JEDEC TRAY (5+1) | ROHS Exempt | SNAGCU | Level-4-260C-72HR | 0 to 90 | TMS 320C6418 ZTS600 |
| TMS320C6418ZTS600.A | Active | Production | FCBGA (ZTS) 288 | 60 JEDEC TRAY (5+1) | ROHS Exempt | SNAGCU | Level-4-260C-72HR | 0 to 90 | TMS 320C6418 ZTS600 |
| TMS320C6418ZTSA500 | Active | Production | FCBGA (ZTS) 288 | 60 JEDEC TRAY (5+1) | ROHS Exempt | SNAGCU | Level-4-260C-72HR | -40 to 105 | TMS 320C6418 ZTSA500 |
| TMS320C6418ZTSA500.A | Active | Production | FCBGA (ZTS) 288 | 60 JEDEC TRAY (5+1) | ROHS Exempt | SNAGCU | Level-4-260C-72HR | -40 to 105 | TMS 320C6418 ZTSA500 |

(1) **Status:** For more details on status, see our [product life cycle](#).

(2) **Material type:** When designated, preproduction parts are prototypes/experimental devices, and are not yet approved or released for full production. Testing and final process, including without limitation quality assurance, reliability performance testing, and/or process qualification, may not yet be complete, and this item is subject to further changes or possible discontinuation. If available for ordering, purchases will be subject to an additional waiver at checkout, and are intended for early internal evaluation purposes only. These items are sold without warranties of any kind.

(3) **RoHS values:** Yes, No, RoHS Exempt. See the [TI RoHS Statement](#) for additional information and value definition.

(4) **Lead finish/Ball material:** Parts may have multiple material finish options. Finish options are separated by a vertical ruled line. Lead finish/Ball material values may wrap to two lines if the finish value exceeds the maximum column width.

(5) **MSL rating/Peak reflow:** The moisture sensitivity level ratings and peak solder (reflow) temperatures. In the event that a part has multiple moisture sensitivity ratings, only the lowest level per JEDEC standards is shown. Refer to the shipping label for the actual reflow temperature that will be used to mount the part to the printed circuit board.

(6) **Part marking:** There may be an additional marking, which relates to the logo, the lot trace code information, or the environmental category of the part.

Multiple part markings will be inside parentheses. Only one part marking contained in parentheses and separated by a "-" will appear on a part. If a line is indented then it is a continuation of the previous line and the two combined represent the entire part marking for that device.

Important Information and Disclaimer: The information provided on this page represents TI's knowledge and belief as of the date that it is provided. TI bases its knowledge and belief on information provided by third parties, and makes no representation or warranty as to the accuracy of such information. Efforts are underway to better integrate information from third parties. TI has taken and continues to take reasonable steps to provide representative and accurate information but may not have conducted destructive testing or chemical analysis on incoming materials and chemicals. TI and TI suppliers consider certain information to be proprietary, and thus CAS numbers and other limited information may not be available for release.

In no event shall TI's liability arising out of such information exceed the total purchase price of the TI part(s) at issue in this document sold by TI to Customer on an annual basis.

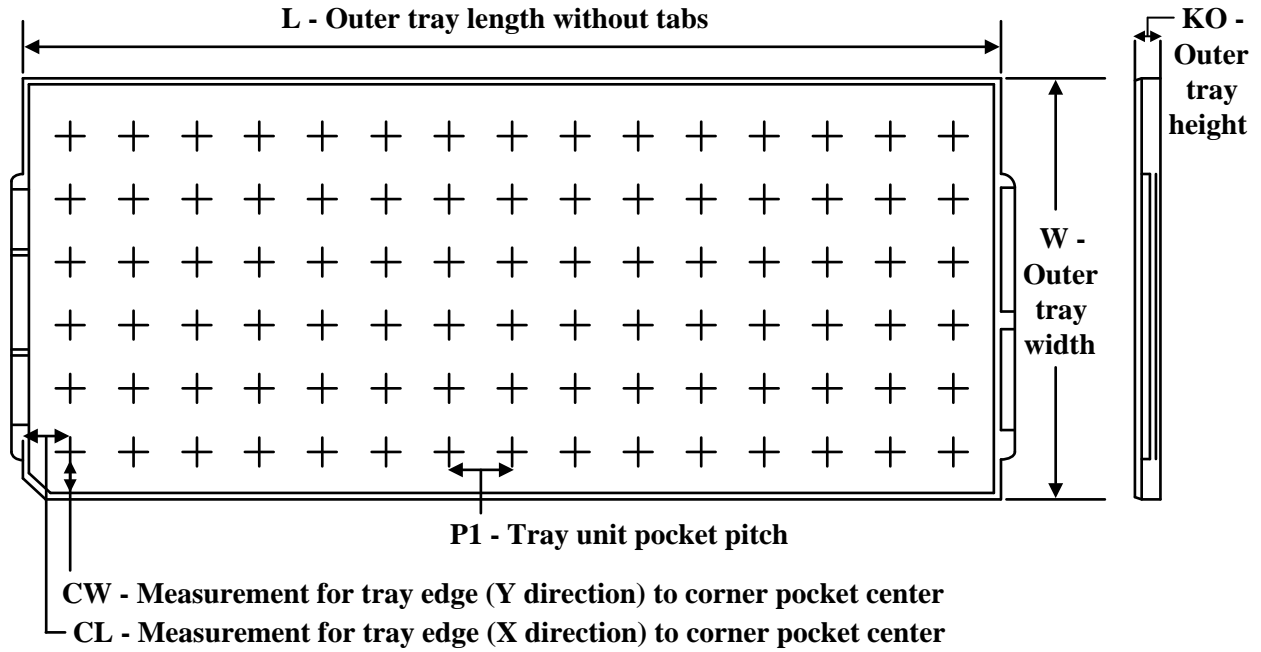
TRAY

Chamfer on Tray corner indicates Pin 1 orientation of packed units.

*All dimensions are nominal

| Device | Package Name | Package Type | Pins | SPQ | Unit array matrix | Max temperature (°C) | L (mm) | W (mm) | K0 (µm) | P1 (mm) | CL (mm) | CW (mm) |
|-----------------------|--------------|--------------|------|-----|-------------------|----------------------|--------|--------|---------|---------|---------|---------|
| TMS320C6418G TSA500 | GTS | FCBGA | 288 | 60 | 5 X 12 | 150 | 315 | 135.9 | 7620 | 25.5 | 17.25 | 16.95 |
| TMS320C6418G TSA500.A | GTS | FCBGA | 288 | 60 | 5 X 12 | 150 | 315 | 135.9 | 7620 | 25.5 | 17.25 | 16.95 |
| TMS320C6418Z TSA600 | ZTS | FCBGA | 288 | 60 | 5 X 12 | 150 | 315 | 135.9 | 7620 | 25.5 | 17.25 | 16.95 |
| TMS320C6418Z TSA600.A | ZTS | FCBGA | 288 | 60 | 5 X 12 | 150 | 315 | 135.9 | 7620 | 25.5 | 17.25 | 16.95 |
| TMS320C6418Z TSA500 | ZTS | FCBGA | 288 | 60 | 5 X 12 | 150 | 315 | 135.9 | 7620 | 25.5 | 17.25 | 16.95 |
| TMS320C6418Z TSA500.A | ZTS | FCBGA | 288 | 60 | 5 X 12 | 150 | 315 | 135.9 | 7620 | 25.5 | 17.25 | 16.95 |

GTS (S-PBGA-N288)

PLASTIC BALL GRID ARRAY

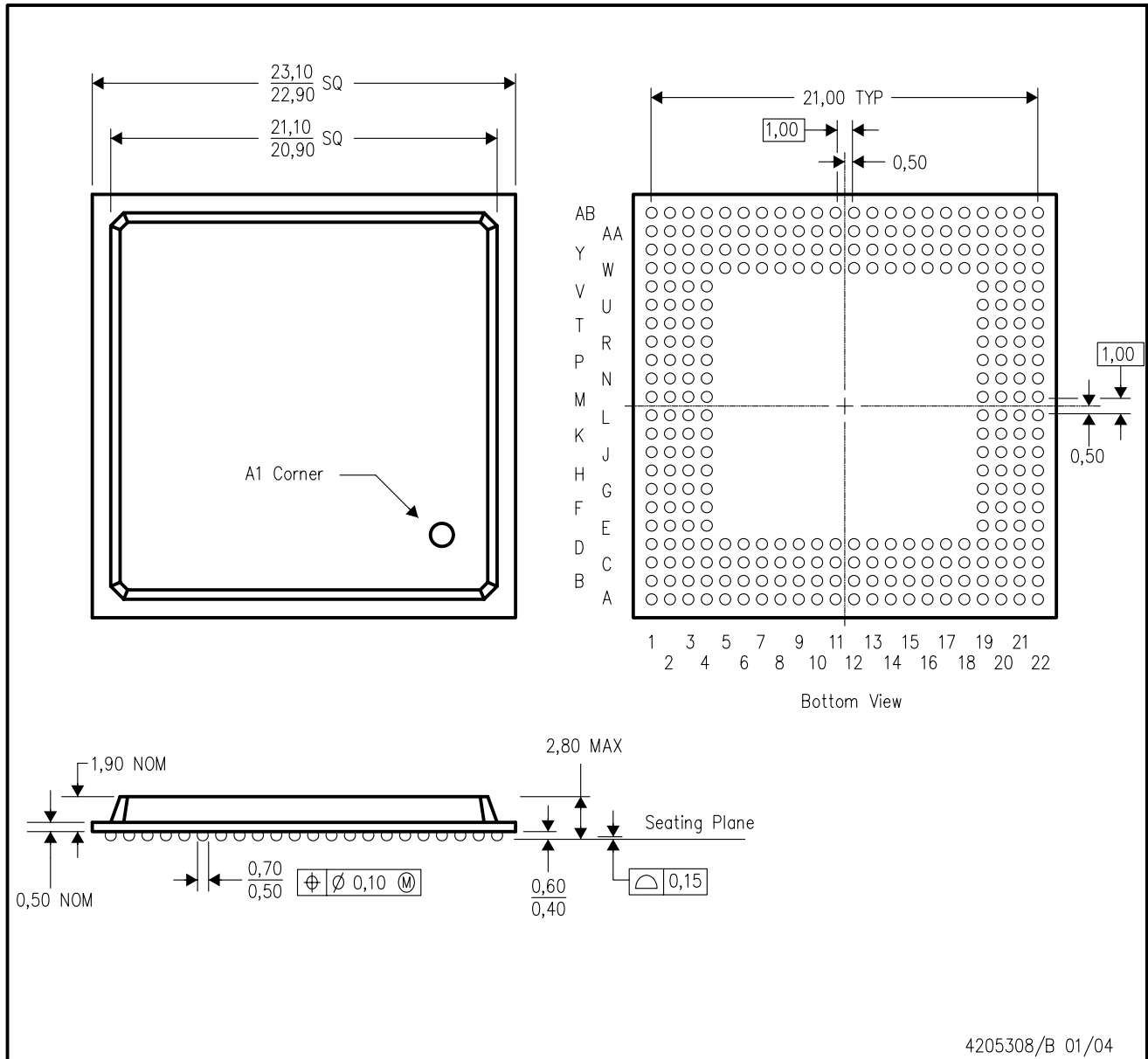

4205308/B 01/04

- NOTES:
- A. All linear dimensions are in millimeters.
 - B. This drawing is subject to change without notice.
 - C. Flip chip application only.
 - D. Falls within JEDEC MS-034B.

ZTS (S-PBGA-N288)

PLASTIC BALL GRID ARRAY

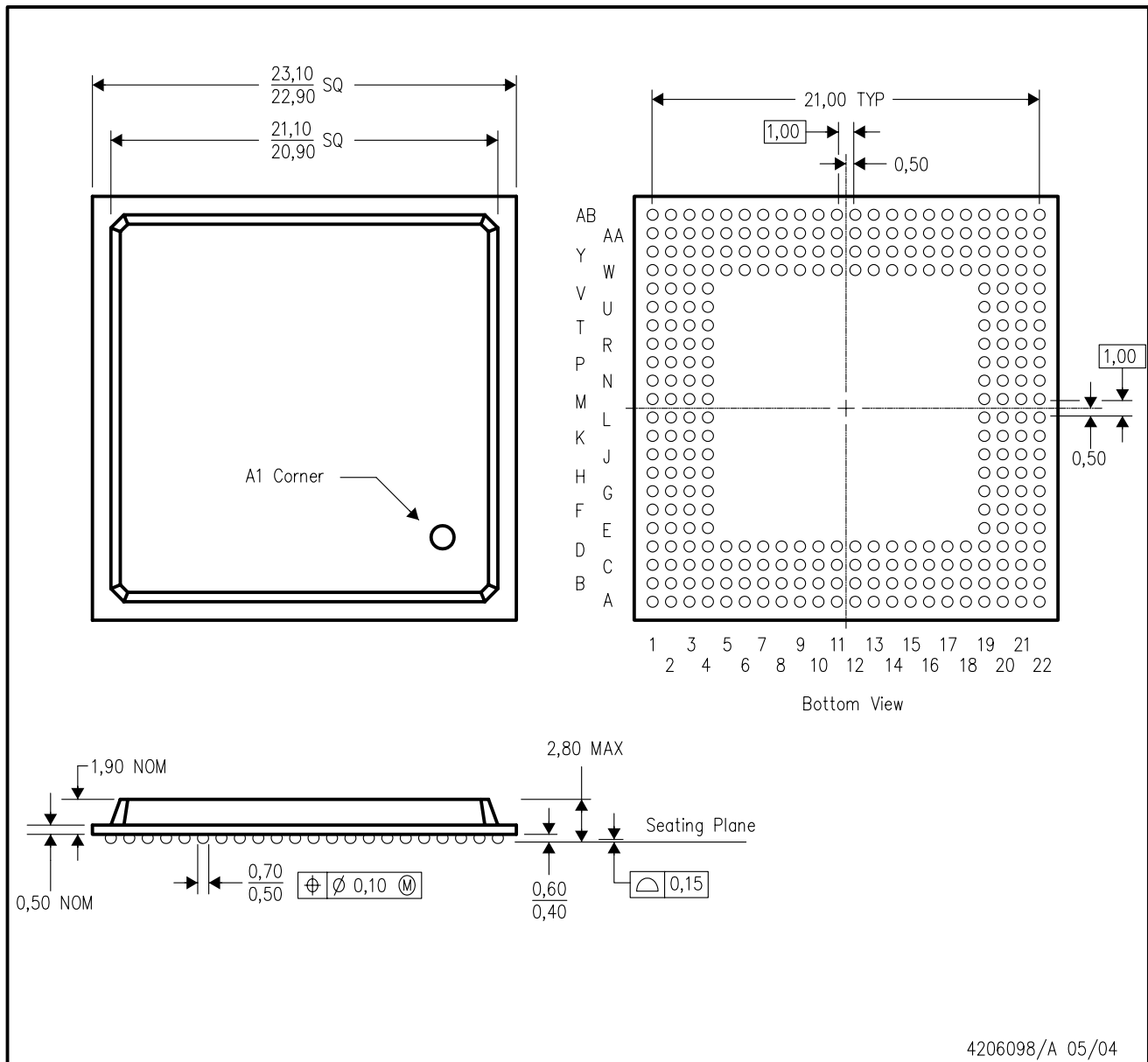

4206098/A 05/04

- NOTES:
- A. All linear dimensions are in millimeters.
 - B. This drawing is subject to change without notice.
 - C. Flip chip application only.
 - D. Falls within JEDEC MS-034B.
 - E. This package is lead-free.

IMPORTANT NOTICE AND DISCLAIMER

TI PROVIDES TECHNICAL AND RELIABILITY DATA (INCLUDING DATASHEETS), DESIGN RESOURCES (INCLUDING REFERENCE DESIGNS), APPLICATION OR OTHER DESIGN ADVICE, WEB TOOLS, SAFETY INFORMATION, AND OTHER RESOURCES "AS IS" AND WITH ALL FAULTS, AND DISCLAIMS ALL WARRANTIES, EXPRESS AND IMPLIED, INCLUDING WITHOUT LIMITATION ANY IMPLIED WARRANTIES OF MERCHANTABILITY, FITNESS FOR A PARTICULAR PURPOSE OR NON-INFRINGEMENT OF THIRD PARTY INTELLECTUAL PROPERTY RIGHTS.

These resources are intended for skilled developers designing with TI products. You are solely responsible for (1) selecting the appropriate TI products for your application, (2) designing, validating and testing your application, and (3) ensuring your application meets applicable standards, and any other safety, security, regulatory or other requirements.

These resources are subject to change without notice. TI grants you permission to use these resources only for development of an application that uses the TI products described in the resource. Other reproduction and display of these resources is prohibited. No license is granted to any other TI intellectual property right or to any third party intellectual property right. TI disclaims responsibility for, and you fully indemnify TI and its representatives against any claims, damages, costs, losses, and liabilities arising out of your use of these resources.

TI's products are provided subject to [TI's Terms of Sale](#), [TI's General Quality Guidelines](#), or other applicable terms available either on ti.com or provided in conjunction with such TI products. TI's provision of these resources does not expand or otherwise alter TI's applicable warranties or warranty disclaimers for TI products. Unless TI explicitly designates a product as custom or customer-specified, TI products are standard, catalog, general purpose devices.

TI objects to and rejects any additional or different terms you may propose.

Copyright © 2026, Texas Instruments Incorporated

Last updated 10/2025