

TPD4E1U06 四通道、高速 ESD 保护器件

1 特性

- IEC 61000-4-2 4 级 ESD 保护
 - $\pm 15\text{kV}$ 接触放电
 - $\pm 15\text{kV}$ 气隙放电
- IEC 61000-4-4 瞬态放电 (EFT) 保护
 - 80A (5/50ns)
- IEC 61000-4-5 浪涌保护
 - 3A (8/20 μs)
- IO 电容: 0.8pF (典型值)
- 直流击穿电压: 6.5V (最小值)
- 超低泄漏电流: 10nA (最大值)
- 低 ESD 钳位电压
- 工业温度范围: -40°C 至 $+125^{\circ}\text{C}$
- 小型、易于布线的 DCK 和 DBV 封装

2 应用

- USB 2.0
- 以太网
- 高清多媒体接口 (HDMI) 控制线路
- 移动产业处理器接口 (MIPI) 总线
- 低压差分信令 (LVDS)
- SATA

3 说明

TPD4E1U06 是一款基于四通道单向瞬态电压抑制器 (TVS) 的静电放电 (ESD) 保护二极管, 具有超低电容。该器件的 ESD 冲击消散值高于 IEC 61000-4-2 国际标准规定的最高水平。其 0.8pF 的线路电容使其广泛适用于各类应用的输出电流传感电阻器和运算放大器而得以实现。典型应用领域包括 HDMI、USB2.0、MHL 和 DisplayPort。

器件信息⁽¹⁾

器件型号	封装	封装尺寸 (标称值)
TPD4E1U06DCK	SC70	2.00mm x 1.25mm
TPD4E1U06DBV	SOT-23	2.90mm x 1.60mm

(1) 如需了解所有可用封装, 请参阅数据表末尾的可订购产品附录。

LP38690 的

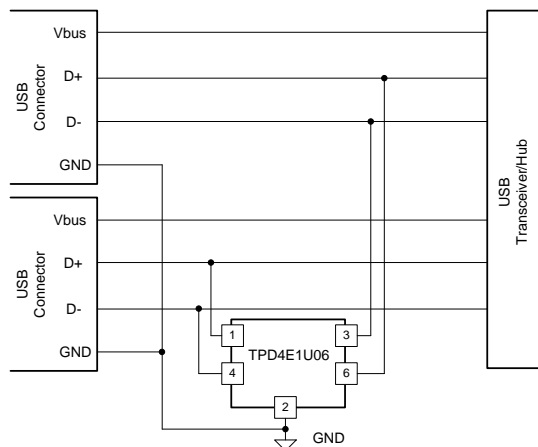

电路原理图

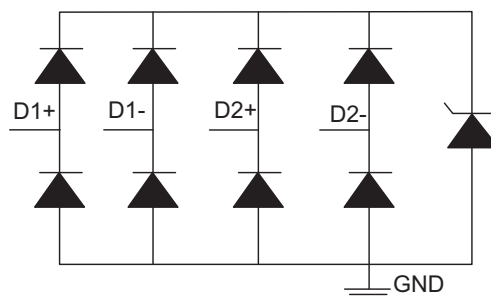

目录

1 特性	1	7.4 Device Functional Modes	9
2 应用	1	8 Application and Implementation	10
3 说明	1	8.1 Application Information	10
4 修订历史记录	2	8.2 Typical Application	10
5 Pin Configuration and Functions	3	9 Power Supply Recommendations	12
6 Specifications	4	10 Layout	12
6.1 Absolute Maximum Ratings	4	10.1 Layout Guidelines	12
6.2 ESD Ratings	4	10.2 Layout Example	12
6.3 ESD Ratings—IEC Specification	4	11 器件和文档支持	13
6.4 Recommended Operating Conditions	4	11.1 文档支持	13
6.5 Thermal Information	4	11.2 接收文档更新通知	13
6.6 Electrical Characteristics	5	11.3 社区资源	13
6.7 Typical Characteristics	6	11.4 商标	13
7 Detailed Description	8	11.5 静电放电警告	13
7.1 Overview	8	11.6 Glossary	13
7.2 Functional Block Diagram	8	12 机械、封装和可订购信息	13
7.3 Feature Description	8		

4 修订历史记录

注：之前版本的页码可能与当前版本有所不同。

Changes from Revision C (October 2014) to Revision D	Page
• Updated DCK and DBV Pinout image	3
• Added 61000-4-5 spec to <i>Absolute Maximum Ratings</i> table	4
• Added <i>IEC 61000-4-5 Surge Protection</i> section	8
• Added <i>IEC 61000-4-4 EFT Protection</i> section	8

Changes from Revision B (February 2013) to Revision C	Page
• 已添加 引脚配置和功能部分，处理额定值表，特性说明部分，器件功能模式，应用和实施部分，电源相关建议部分，布局部分，器件和文档支持部分以及机械、封装和可订购信息部分	1

Changes from Revision A (December 2012) to Revision B	Page
• Added C _{CROSS} data for DBV package	5

5 Pin Configuration and Functions

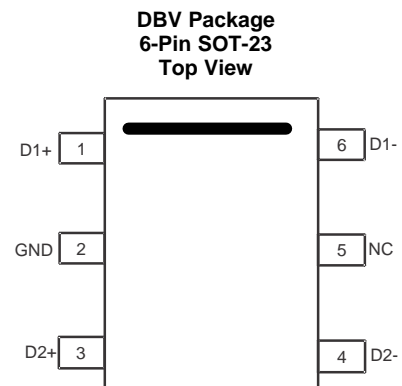
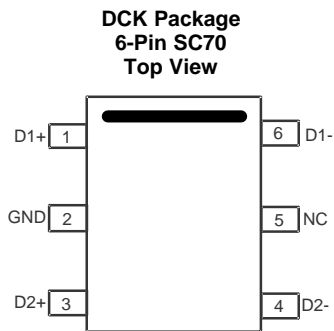

Pin Functions

PIN		I/O	DESCRIPTION
NAME	NO.		
D1+	1	I/O	ESD protected channel. Connect to data line as close to the connector as possible
D1-	6	I/O	
D2-	4	I/O	
D2+	3	I/O	
GND	2	GND	Ground. Connect to ground
NC	5	I/O	No connect. Can be left floating, grounded, or connected to VCC

6 Specifications

6.1 Absolute Maximum Ratings

over operating free-air temperature range (unless otherwise noted) ⁽¹⁾

		MIN	MAX	UNIT
	IEC 61000-4-4 EFT protection (5/50 ns)		80	A
I_{PP}	IEC 61000-4-5 surge protection (8/20 μ s) peak pulse current		3	A
P_{PP}	IEC 61000-4-5 surge protection (8/20 μ s) peak pulse power		45	W
	Operating temperature	-40	125	°C
T_{stg}	Storage temperature	-65	115	°C

- (1) Stresses beyond those listed under *Absolute Maximum Ratings* may cause permanent damage to the device. These are stress ratings only, which do not imply functional operation of the device at these or any other conditions beyond those indicated under *Recommended Operating Conditions*. Exposure to absolute-maximum-rated conditions for extended periods may affect device reliability.

6.2 ESD Ratings

		VALUE	UNIT
$V_{(ESD)}$	Electrostatic discharge		V
	Human body model (HBM), per ANSI/ESDA/JEDEC JS-001, all pins ⁽¹⁾	±4000	
	Charged device model (CDM), per JEDEC specification JESD22-C101, all pins ⁽²⁾	±1500	

- (1) JEDEC document JEP155 states that 500-V HBM allows safe manufacturing with a standard ESD control process.
 (2) JEDEC document JEP157 states that 250-V CDM allows safe manufacturing with a standard ESD control process.

6.3 ESD Ratings—IEC Specification

		VALUE	UNIT
$V_{(ESD)}$	Electrostatic discharge		V
	IEC 61000-4-2 contact ESD	±15000	
	IEC 61000-4-2 air-gap ESD	±15000	

6.4 Recommended Operating Conditions

over operating free-air temperature range (unless otherwise noted)

		MIN	MAX	UNIT
V_{IO}	Input pin voltage	0	5.5	V
T_A	Operating free-air temperature	-40	125	°C

6.5 Thermal Information

THERMAL METRIC ⁽¹⁾	TPD4E1U06		UNIT	
	DBV (SOT-23)	DCK (SC-70)		
	6 PINS	6 PINS		
$R_{\theta JA}$	Junction-to-ambient thermal resistance	224.3	274.3	°C/W
$R_{\theta JC(top)}$	Junction-to-case (top) thermal resistance	166.1	113.8	°C/W
$R_{\theta JB}$	Junction-to-board thermal resistance	68.4	76.7	°C/W
Ψ_{JT}	Junction-to-top characterization parameter	57.3	3.6	°C/W
Ψ_{JB}	Junction-to-board characterization parameter	67.9	75.9	°C/W

- (1) For more information about traditional and new thermal metrics, see the [Semiconductor and IC Package Thermal Metrics](#) application report.

6.6 Electrical Characteristics

over recommended operating free-air temperature range (unless otherwise noted)

PARAMETER		TEST CONDITIONS		MIN	TYP	MAX	UNIT
V_{RWM}	Reverse stand-off voltage	$I_{IO} = 10 \mu A$				5.5	V
V_{CLAMP}	Clamp voltage with ESD strike	$I_{PP} = 1 A, t_p = 8/20 \mu s, \text{ from I/O to GND}^{(1)}$			11		V
		$I_{PP} = 3 A, t_p = 8/20 \mu s, \text{ from I/O to GND}^{(1)}$			15		V
R_{DYN}	Dynamic resistance	Pin x to GND pin ⁽²⁾			1.0		Ω
		GND to pin x			0.6		
C_L	Line capacitance	$f = 1 \text{ MHz}, V_{BIAS} = 2.5 \text{ V}, 25^\circ C$			0.8	1	pF
C_{CROSS}	Channel to channel input capacitance	Pin 2 = 0 V, $f = 1 \text{ MHz}, V_{BIAS} = 2.5 \text{ V}$, between channel pins	DCK package		0.006	0.015	pF
			DBV package		0.01	0.025	
$\Delta C_{IO-TO-GND}$	Variation of channel input capacitance	Pin 2 = 0 V, $f = 1 \text{ MHz}, V_{BIAS} = 2.5 \text{ V}$, channel_x pin to ground – channel_y pin to ground			0.025	0.07	pF
V_{BR}	Break-down voltage, IO to GND	$I_{IO} = 1 \text{ mA}$		6.5		8.5	V
I_{LEAK}	Leakage current	$V_{IO} = 2.5 \text{ V}$			1	10	nA

(1) Non-repetitive current pulse 8/20 μs exponentially decaying waveform according to IEC61000-4-5.

(2) Extraction of R_{DYN} using least squares fit of TLP characteristics between $I = 10 \text{ A}$ and $I = 20 \text{ A}$.

6.7 Typical Characteristics

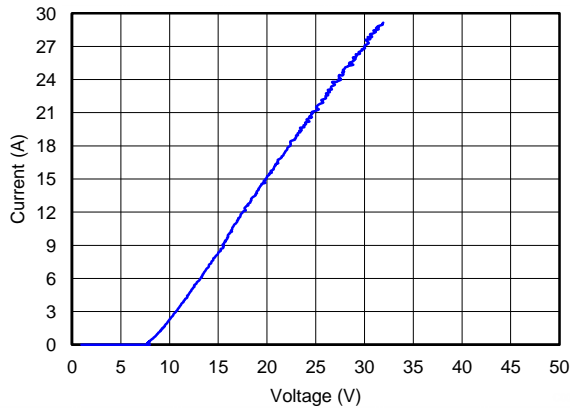

Figure 1. TLP, Data to GND

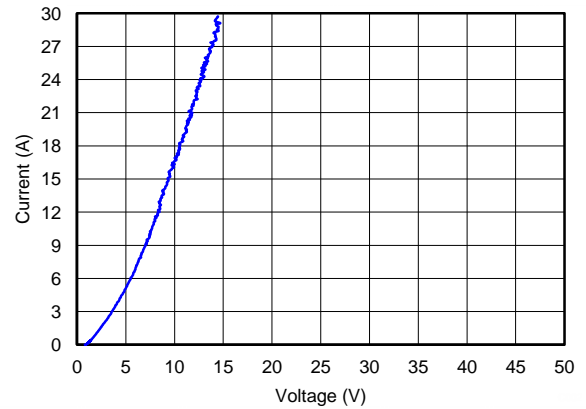

Figure 2. TLP, GND to Data

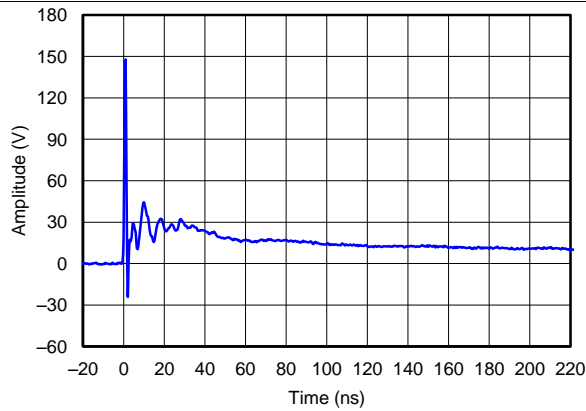

Figure 3. IEC 61000-4-2 Clamping Voltage, 8-kV Contact

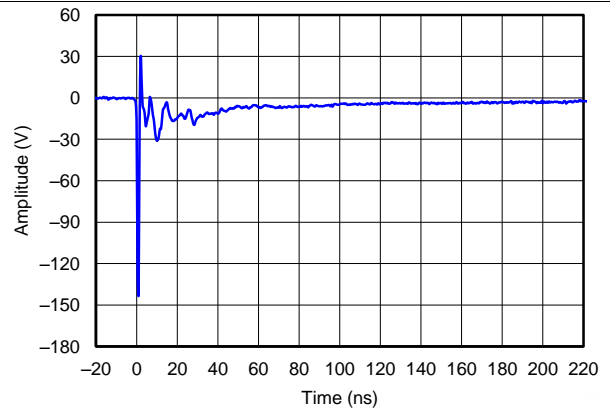

Figure 4. IEC 61000-4-2 Clamping Voltage, -8-kV Contact

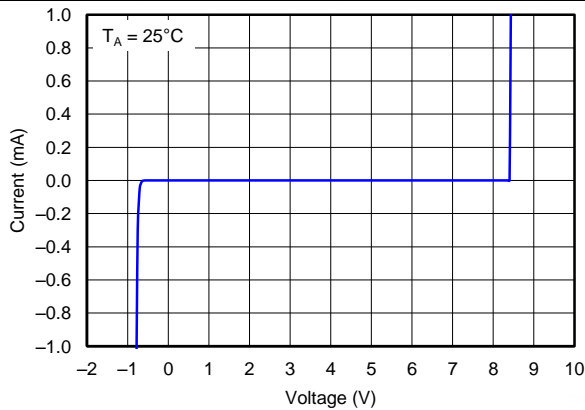

Figure 5. Diode Curve

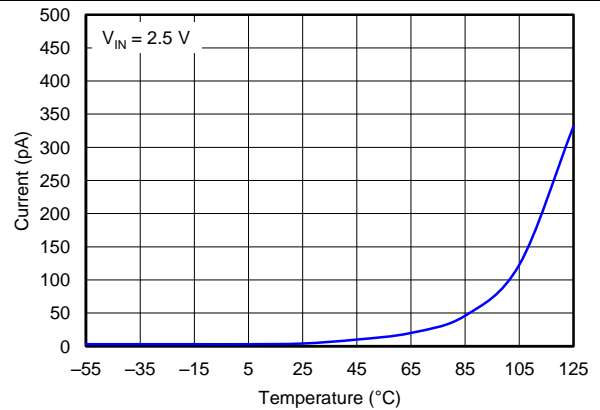

Figure 6. I_{LEAK} vs Temperature

Typical Characteristics (continued)

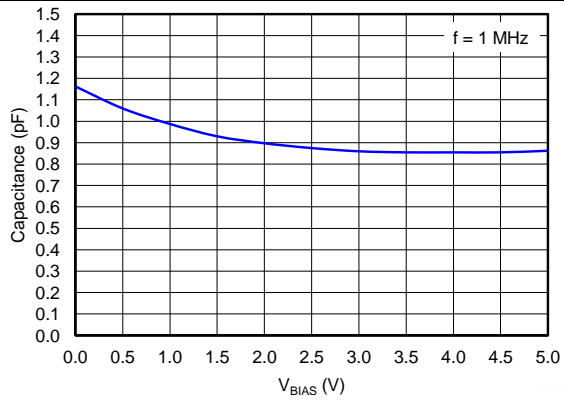

Figure 7. Capacitance Across V_{BIAS}

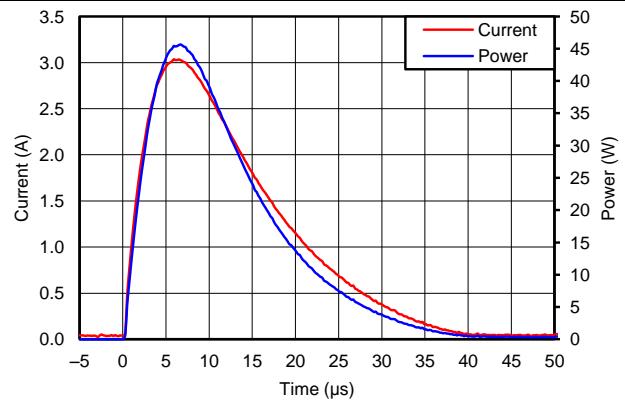

Figure 8. Surge Curve (tp = 8/20 μs), Pin IO to GND

7 Detailed Description

7.1 Overview

The TPD4E1U06 is a quad channel unidirectional TVS ESD protection diode with ultra low capacitance. This device can dissipate ESD strikes above the maximum level specified by the IEC 61000-4-2 international standard. Typical application areas include HDMI, USB2.0, MHL, and DisplayPort. Its 0.8-pF line capacitance makes it suitable for a wide range of applications.

7.2 Functional Block Diagram

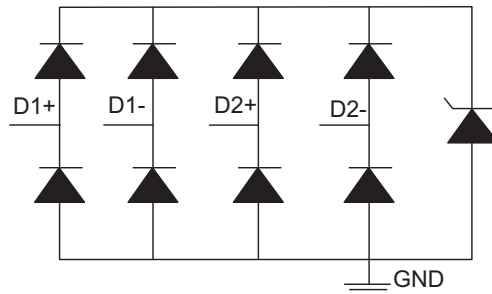

Figure 9. Circuit Schematic Diagram

7.3 Feature Description

7.3.1 IEC 61000-4-2 Level 4 ESD Protection

The I/O pins can withstand ESD events up to ± 15 -kV contact and air. An ESD/surge clamp diverts the current to ground.

7.3.2 IEC 61000-4-5 Surge Protection

The IO pins can withstand surge events up to 3 A and 45 W (8/20- μ s waveform). An ESD-surge clamp diverts this current to ground.

7.3.3 IEC 61000-4-4 EFT Protection

The IO pins can withstand an electrical fast transient burst of up to 80 A (5/50-ns waveform, 4 kV with 50- Ω impedance). An ESD-surge clamp diverts the current to ground.

7.3.4 IO Capacitance

The capacitance between each I/O pin to ground is 0.8 pF.

7.3.5 DC Breakdown Voltage

The DC breakdown voltage of each I/O pin is a minimum of 6.5 V. This ensures that sensitive equipment is protected from surges above the reverse standoff voltage of 5.5 V.

7.3.6 Ultra Low Leakage Current

The I/O pins feature an ultra-low leakage current of 10 nA (Maximum) with a bias of 2.5 V.

7.3.7 Low ESD Clamping Voltage

The I/O pins feature an ESD clamp that is capable of clamping the voltage to 11 V ($I_{PP} = 1$ A).

7.3.8 Industrial Temperature Range

This device features an industrial operating range of -40°C to $+125^{\circ}\text{C}$.

Feature Description (continued)

7.3.9 Small, Easy-to-Route Packages

The layout of this device makes it simple to add protection to the design. Industry standard packages allow for easy additions to the board and easy layout.

7.4 Device Functional Modes

The TPD4E1U06 is a passive integrated circuit that triggers when voltages are above V_{BR} or below the forward diode drop. During ESD events, voltages as high as ± 15 kV can be directed to ground via the internal diode network. Once the voltages on the protected line fall below the trigger levels of TPD4E1U06 (usually within 10s of nano-seconds) the device reverts to passive.

8 Application and Implementation

NOTE

Information in the following applications sections is not part of the TI component specification, and TI does not warrant its accuracy or completeness. TI's customers are responsible for determining suitability of components for their purposes. Customers should validate and test their design implementation to confirm system functionality.

8.1 Application Information

The TPD4E1U06 is a TVS diode array which is typically used to provide a path to ground for dissipating ESD events on hi-speed signal lines between a human interface connector and a system. As the current from ESD passes through the TVS, only a small voltage drop is present across the diode. This is the voltage presented to the protected IC. The low R_{DYN} of the triggered TVS holds this voltage, V_{CLAMP} , to a safe level for the protected IC.

8.2 Typical Application

For this design example, one TPD4E1U06 device is being used in a dual USB 2.0 application. This provides a complete port protection scheme.

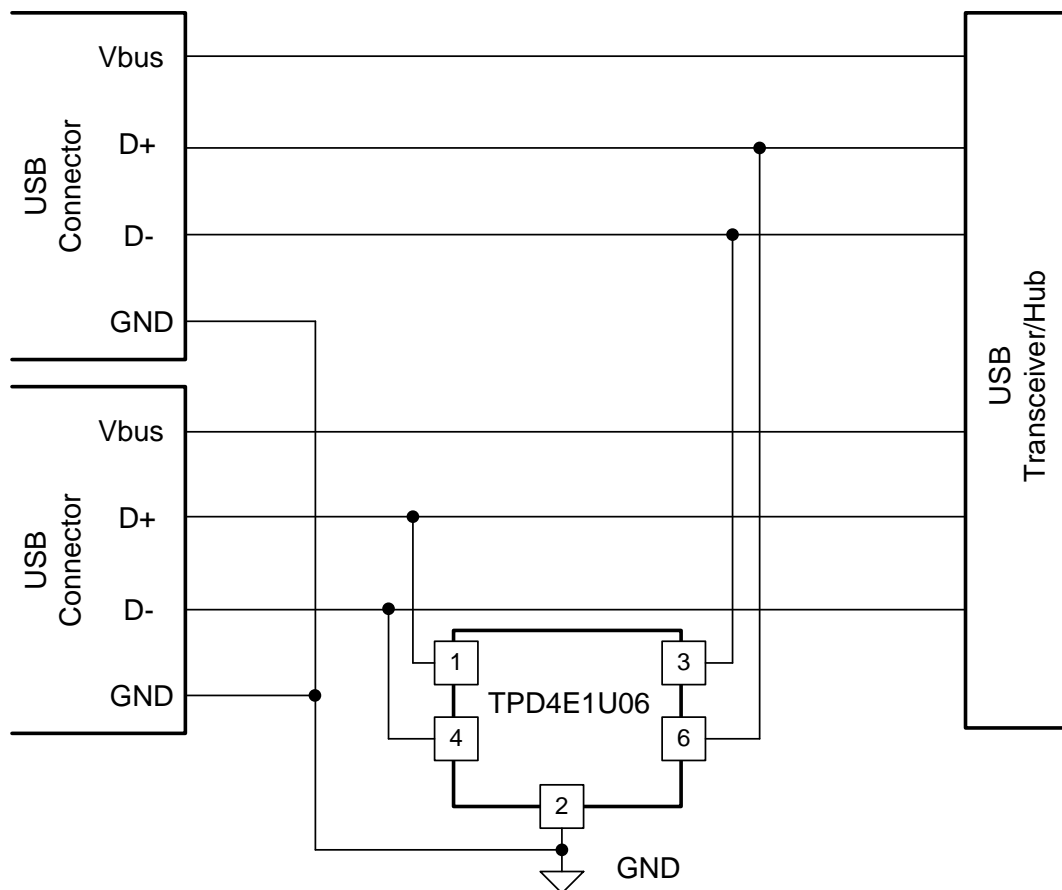

Figure 10. Dual USB 2.0 Application

Typical Application (continued)

8.2.1 Design Requirements

Given the USB 2.0 application, the parameters in [Table 1](#) are known.

Table 1. Design Parameters

DESIGN PARAMETER	VALUE
Signal range on pins 1, 3, 4, or 6	0 V to 5 V
Operating frequency	240 MHz

8.2.2 Detailed Design Procedure

8.2.2.1 Signal Range on Pins 1, 3, 4, or 6

The TPD4E1U06 has 4 identical protection channels for signal lines. The symmetry of the device provides flexibility when selecting which of the 4 I/O channels protect which signal lines. Any I/O supports a signal range of 0 to 5.5 V.

8.2.2.2 Operating Frequency

The TPD4E1U06 has a capacitance of 0.8 pF (typical), supporting USB 2.0 data rates.

8.2.3 Application Curve

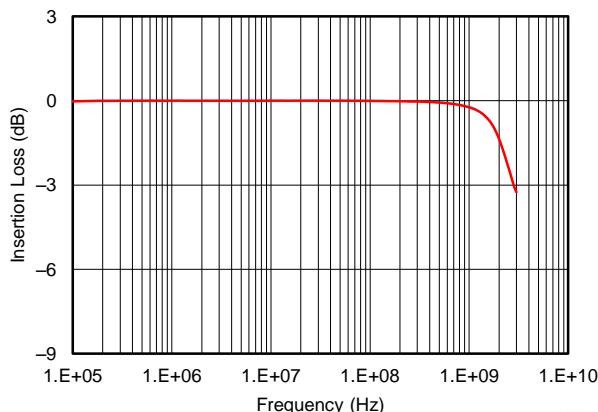

Figure 11. Insertion Loss Graph

9 Power Supply Recommendations

This device is a passive ESD device so there is no need to power it. Take care not to violate the recommended I/O specification (0 V to 5.5 V) to ensure the device functions properly.

10 Layout

10.1 Layout Guidelines

- The optimum placement is as close to the connector as possible.
 - EMI during an ESD event can couple from the trace being struck to other nearby unprotected traces, resulting in early system failures.
 - The PCB designer needs to minimize the possibility of EMI coupling by keeping any unprotected traces away from the protected traces which are between the TVS and the connector.
- Route the protected traces as straight as possible.
- Eliminate any sharp corners on the protected traces between the TVS and the connector by using rounded corners with the largest radii possible.
 - Electric fields tend to build up on corners, increasing EMI coupling.

10.2 Layout Example

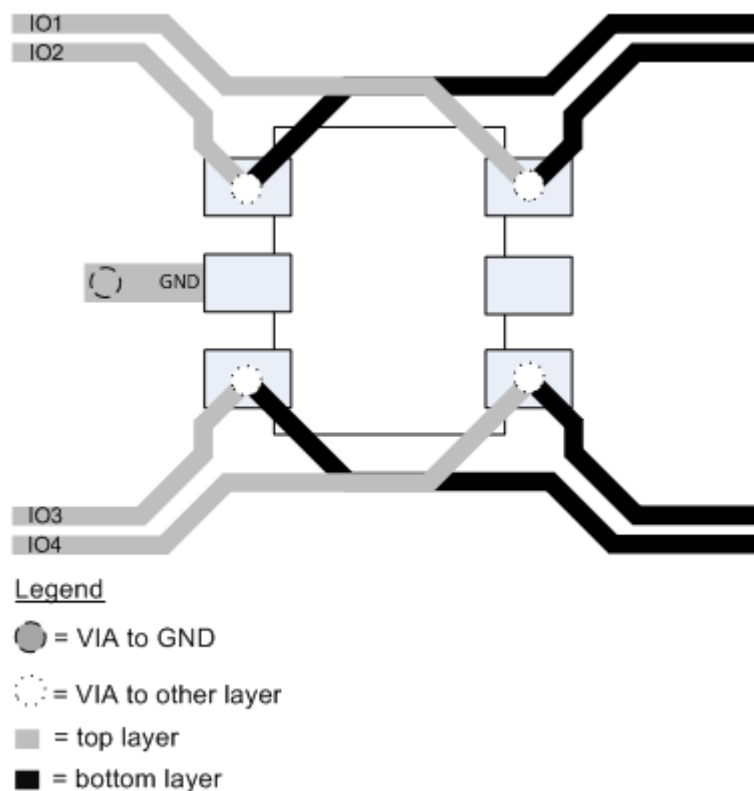

Figure 12. PCB Layout Recommendation

11 器件和文档支持

11.1 文档支持

11.1.1 相关文档

请参阅如下相关文档：

- [阅读和理解 ESD 保护数据表](#)
- [《ESD 布局指南》](#)
- [TPD4E1U06DCK EVM 用户指南](#)
- [TPD4E1U06DBV EVM 用户指南](#)

11.2 接收文档更新通知

要接收文档更新通知（包括芯片勘误表），请转至 [ti.com.cn](#) 上您的器件对应的产品文件夹。单击右上角的“提醒我” (*Alert me*) 按钮。点击后，您将每周定期收到已更改的产品信息（如果有的话）。有关更改的详细信息，请查看任意已修订文档的修订历史记录。

11.3 社区资源

下列链接提供到 TI 社区资源的连接。链接的内容由各个分销商“按照原样”提供。这些内容并不构成 TI 技术规范，并且不一定反映 TI 的观点；请参阅 TI 的 [《使用条款》](#)。

TI E2E™ 在线社区 *TI 的工程师对工程师 (E2E) 社区*。此社区的创建目的在于促进工程师之间的协作。在 [e2e.ti.com](#) 中，您可以咨询问题、分享知识、拓展思路并与同行工程师一道帮助解决问题。

设计支持 *TI 参考设计支持* 可帮助您快速查找有帮助的 E2E 论坛、设计支持工具以及技术支持的联系信息。

11.4 商标

E2E is a trademark of Texas Instruments.
All other trademarks are the property of their respective owners.

11.5 静电放电警告



这些装置包含有限的内置 ESD 保护。存储或装卸时，应将导线一起截短或将装置放置于导电泡棉中，以防止 MOS 门极遭受静电损伤。

11.6 Glossary

[SLYZ022](#) — *TI Glossary*.

This glossary lists and explains terms, acronyms, and definitions.

12 机械、封装和可订购信息

以下页面包括机械、封装和可订购信息。这些信息是指定器件的最新可用数据。这些数据发生变化时，我们可能不会另行通知或修订此文档。如欲获取此产品说明书的浏览器版本，请参见左侧的导航栏。

PACKAGING INFORMATION

Orderable part number	Status (1)	Material type (2)	Package Pins	Package qty Carrier	RoHS (3)	Lead finish/ Ball material (4)	MSL rating/ Peak reflow (5)	Op temp (°C)	Part marking (6)
TPD4E1U06DBVR	Active	Production	SOT-23 (DBV) 6	3000 LARGE T&R	Yes	NIPDAU SN	Level-1-260C-UNLIM	-40 to 125	(NG4, NG4P)
TPD4E1U06DBVR.B	Active	Production	SOT-23 (DBV) 6	3000 LARGE T&R	Yes	NIPDAU	Level-1-260C-UNLIM	-40 to 125	(NG4, NG4P)
TPD4E1U06DCKR	Active	Production	SC70 (DCK) 6	3000 LARGE T&R	Yes	NIPDAU SN	Level-1-260C-UNLIM	-40 to 125	(BP6, BP8, BPI) (BPP, BPP, BPS)
TPD4E1U06DCKR.B	Active	Production	SC70 (DCK) 6	3000 LARGE T&R	Yes	SN	Level-1-260C-UNLIM	-40 to 125	(BP6, BP8, BPI) (BPP, BPP, BPS)

(1) **Status:** For more details on status, see our [product life cycle](#).

(2) **Material type:** When designated, preproduction parts are prototypes/experimental devices, and are not yet approved or released for full production. Testing and final process, including without limitation quality assurance, reliability performance testing, and/or process qualification, may not yet be complete, and this item is subject to further changes or possible discontinuation. If available for ordering, purchases will be subject to an additional waiver at checkout, and are intended for early internal evaluation purposes only. These items are sold without warranties of any kind.

(3) **RoHS values:** Yes, No, RoHS Exempt. See the [TI RoHS Statement](#) for additional information and value definition.

(4) **Lead finish/Ball material:** Parts may have multiple material finish options. Finish options are separated by a vertical ruled line. Lead finish/Ball material values may wrap to two lines if the finish value exceeds the maximum column width.

(5) **MSL rating/Peak reflow:** The moisture sensitivity level ratings and peak solder (reflow) temperatures. In the event that a part has multiple moisture sensitivity ratings, only the lowest level per JEDEC standards is shown. Refer to the shipping label for the actual reflow temperature that will be used to mount the part to the printed circuit board.

(6) **Part marking:** There may be an additional marking, which relates to the logo, the lot trace code information, or the environmental category of the part.

Multiple part markings will be inside parentheses. Only one part marking contained in parentheses and separated by a "-" will appear on a part. If a line is indented then it is a continuation of the previous line and the two combined represent the entire part marking for that device.

Important Information and Disclaimer:The information provided on this page represents TI's knowledge and belief as of the date that it is provided. TI bases its knowledge and belief on information provided by third parties, and makes no representation or warranty as to the accuracy of such information. Efforts are underway to better integrate information from third parties. TI has taken and continues to take reasonable steps to provide representative and accurate information but may not have conducted destructive testing or chemical analysis on incoming materials and chemicals. TI and TI suppliers consider certain information to be proprietary, and thus CAS numbers and other limited information may not be available for release.

In no event shall TI's liability arising out of such information exceed the total purchase price of the TI part(s) at issue in this document sold by TI to Customer on an annual basis.

TAPE AND REEL INFORMATION

QUADRANT ASSIGNMENTS FOR PIN 1 ORIENTATION IN TAPE

*All dimensions are nominal

Device	Package Type	Package Drawing	Pins	SPQ	Reel Diameter (mm)	Reel Width W1 (mm)	A0 (mm)	B0 (mm)	K0 (mm)	P1 (mm)	W (mm)	Pin1 Quadrant
TPD4E1U06DBVR	SOT-23	DBV	6	3000	180.0	8.4	3.2	3.2	1.4	4.0	8.0	Q3
TPD4E1U06DCKR	SC70	DCK	6	3000	178.0	9.2	2.4	2.4	1.22	4.0	8.0	Q3
TPD4E1U06DCKR	SC70	DCK	6	3000	180.0	8.4	2.3	2.55	1.2	4.0	8.0	Q3

TAPE AND REEL BOX DIMENSIONS



*All dimensions are nominal

Device	Package Type	Package Drawing	Pins	SPQ	Length (mm)	Width (mm)	Height (mm)
TPD4E1U06DBVR	SOT-23	DBV	6	3000	210.0	185.0	35.0
TPD4E1U06DCKR	SC70	DCK	6	3000	180.0	180.0	18.0
TPD4E1U06DCKR	SC70	DCK	6	3000	210.0	185.0	35.0

EXAMPLE BOARD LAYOUT

DBV0006A

SOT-23 - 1.45 mm max height

SMALL OUTLINE TRANSISTOR

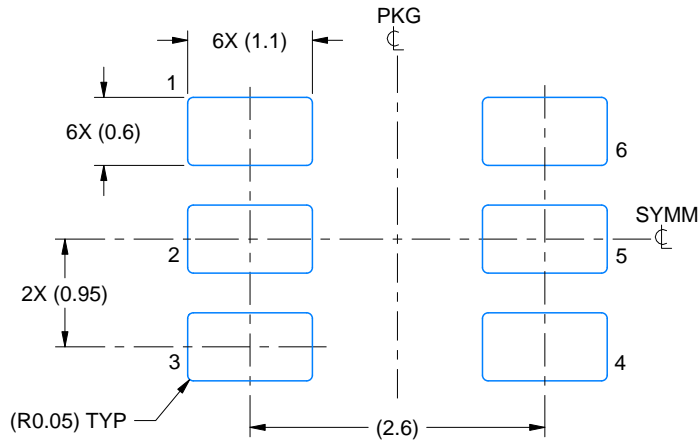

LAND PATTERN EXAMPLE
EXPOSED METAL SHOWN
SCALE:15X



SOLDER MASK DETAILS

4214840/G 08/2024

NOTES: (continued)

6. Publication IPC-7351 may have alternate designs.
7. Solder mask tolerances between and around signal pads can vary based on board fabrication site.

EXAMPLE STENCIL DESIGN

DBV0006A

SOT-23 - 1.45 mm max height

SMALL OUTLINE TRANSISTOR

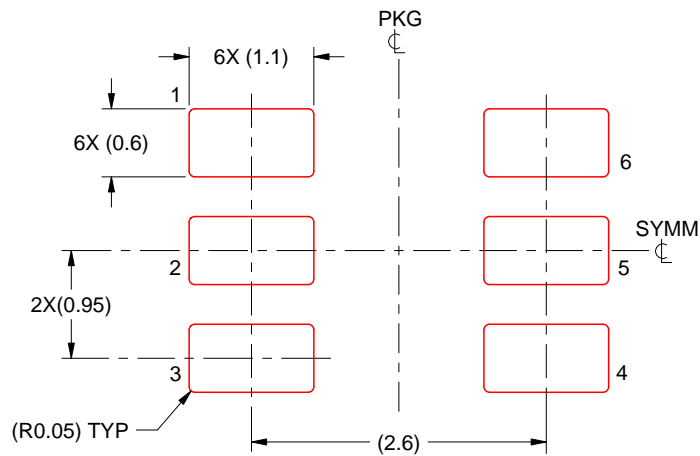

SOLDER PASTE EXAMPLE
BASED ON 0.125 mm THICK STENCIL
SCALE:15X

4214840/G 08/2024

NOTES: (continued)

8. Laser cutting apertures with trapezoidal walls and rounded corners may offer better paste release. IPC-7525 may have alternate design recommendations.
9. Board assembly site may have different recommendations for stencil design.

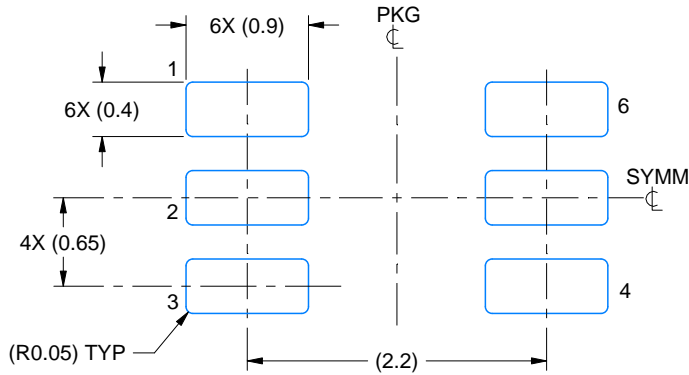

LAND PATTERN EXAMPLE
EXPOSED METAL SHOWN
SCALE:18X

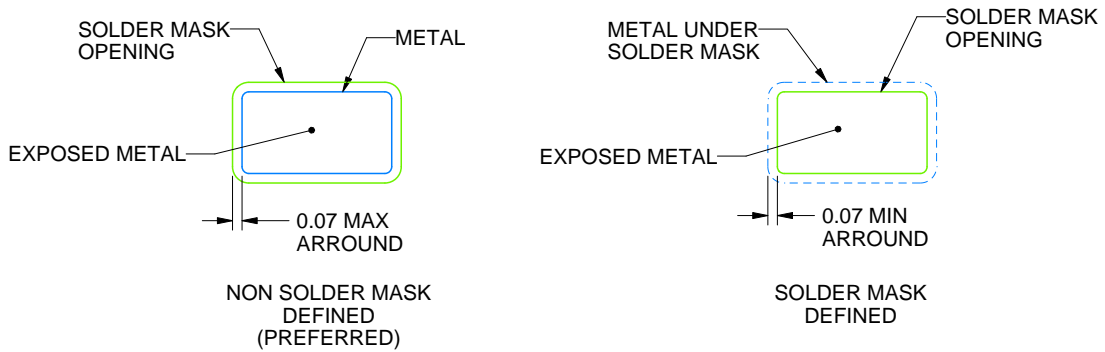

SOLDER MASK DETAILS

4214835/D 11/2024

NOTES: (continued)

- 5. Publication IPC-7351 may have alternate designs.
- 6. Solder mask tolerances between and around signal pads can vary based on board fabrication site.

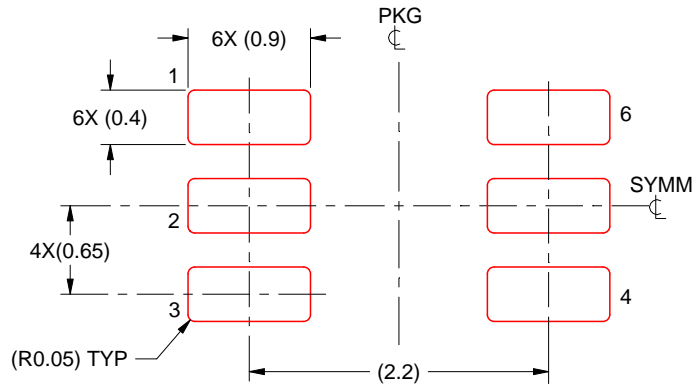

SOLDER PASTE EXAMPLE
BASED ON 0.125 THICK STENCIL
SCALE:18X

4214835/D 11/2024

NOTES: (continued)

7. Laser cutting apertures with trapezoidal walls and rounded corners may offer better paste release. IPC-7525 may have alternate design recommendations.
8. Board assembly site may have different recommendations for stencil design.

重要通知和免责声明

TI“按原样”提供技术和可靠性数据（包括数据表）、设计资源（包括参考设计）、应用或其他设计建议、网络工具、安全信息和其他资源，不保证没有瑕疵且不做任何明示或暗示的担保，包括但不限于对适销性、与某特定用途的适用性或不侵犯任何第三方知识产权的暗示担保。

这些资源可供使用 TI 产品进行设计的熟练开发人员使用。您将自行承担以下全部责任：(1) 针对您的应用选择合适的 TI 产品，(2) 设计、验证并测试您的应用，(3) 确保您的应用满足相应标准以及任何其他安全、安保法规或其他要求。

这些资源如有变更，恕不另行通知。TI 授权您仅可将这些资源用于研发本资源所述的 TI 产品的相关应用。严禁以其他方式对这些资源进行复制或展示。您无权使用任何其他 TI 知识产权或任何第三方知识产权。对于因您对这些资源的使用而对 TI 及其代表造成的任何索赔、损害、成本、损失和债务，您将全额赔偿，TI 对此概不负责。

TI 提供的产品受 [TI 销售条款](#)、[TI 通用质量指南](#) 或 [ti.com](#) 上其他适用条款或 TI 产品随附的其他适用条款的约束。TI 提供这些资源并不会扩展或以其他方式更改 TI 针对 TI 产品发布的适用的担保或担保免责声明。除非德州仪器 (TI) 明确将某产品指定为定制产品或客户特定产品，否则其产品均为按确定价格收入目录的标准通用器件。

TI 反对并拒绝您可能提出的任何其他或不同的条款。

版权所有 © 2026，德州仪器 (TI) 公司

最后更新日期：2025 年 10 月