

# TPS2212

## SINGLE-SLOT, PARALLEL INTERFACE POWER SWITCH FOR LOW POWER PC CARD SLOTS

SLVS193A – APRIL 1999 – REVISED JANUARY 2001

- Fully Integrated  $V_{CC}$  and  $V_{pp}$  Switching for Low Power Single-Slot PC Card™ Interface
- Low  $r_{DS(on)}$  (160-m $\Omega$   $V_{CC}$  Switches)
- Low Current Limit, 450 mA ( $V_{CC}$ ) Typ
- 3.3-V Low-Voltage Mode
- 12-V Supply Can Be Disabled Except During 12-V Flash Programming
- Short-Circuit and Thermal Protection
- Space-Saving 16-Pin SSOP (DB)
- Compatible With 3.3-V, 5-V, and 12-V PC Cards
- Break-Before-Make Switching
- Typical Applications Include: PCMCIA PC Card Sockets in PDAs, PBXs, Bar Code Scanners, Compact Flash and Smart Cards

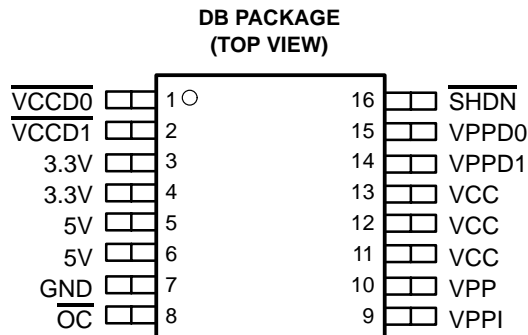

### description

The TPS2212 PC Card power-interface switch provides an integrated power-management solution for a single low power PC Card. All of the discrete power MOSFETs, a logic section, current limiting, and thermal protection for PC Card control are combined on a single integrated circuit, using the Texas Instruments LinBiCMOS™ process. The circuit allows the distribution of 3.3-V, 5-V, and/or 12-V card power, and is compatible with many PCMCIA controllers. The current-limiting feature eliminates the need for fuses, which reduces component count and improves reliability. Current-limit reporting can help the user isolate a system fault to the PC Card.

The TPS2212 features a 3.3-V low-voltage mode that allows for 3.3-V switching without the need for 5 V. Bias power can be derived from either the 3.3-V or 5-V inputs. This facilitates low-power system designs such as sleep mode and pager mode, where only 3.3 V is available.

End equipment for the TPS2212 includes notebook computers, desktop computers, personal digital assistants (PDAs), digital cameras, and bar-code scanners. This device is well suited for those applications that need to limit the power provided to the PC card because of power-supply constraints. In many applications, such as palm computers, the system cannot allocate more than 200 mA of current to a PC card slot. For these lower-power applications, the TPS2212 provides the same advanced level of protection that the TPS2211 provides for higher-power applications.

#### AVAILABLE OPTIONS

T <sub>A</sub>	PACKAGED DEVICE
	SMALL OUTLINE (DB)
–40°C to 85°C	TPS2212IDB

The DB package is available taped and reeled. Add an R suffix to the device type (e.g., TPS2212IDBR) for taped and reeled.



Please be aware that an important notice concerning availability, standard warranty, and use in critical applications of Texas Instruments semiconductor products and disclaimers thereto appears at the end of this data sheet.

PC Card is a trademark of PCMCIA (Personal Computer Memory Card International Association).  
LinBiCMOS is a trademark of Texas Instruments.

PRODUCTION DATA information is current as of publication date. Products conform to specifications per the terms of Texas Instruments standard warranty. Production processing does not necessarily include testing of all parameters.



POST OFFICE BOX 655303 • DALLAS, TEXAS 75265

Copyright © 2001, Texas Instruments Incorporated

# TPS2212 SINGLE-SLOT, PARALLEL INTERFACE POWER SWITCH FOR LOW POWER PC CARD SLOTS

SLVS193A – APRIL 1999 – REVISED JANUARY 2001

## typical PC-card power-distribution application

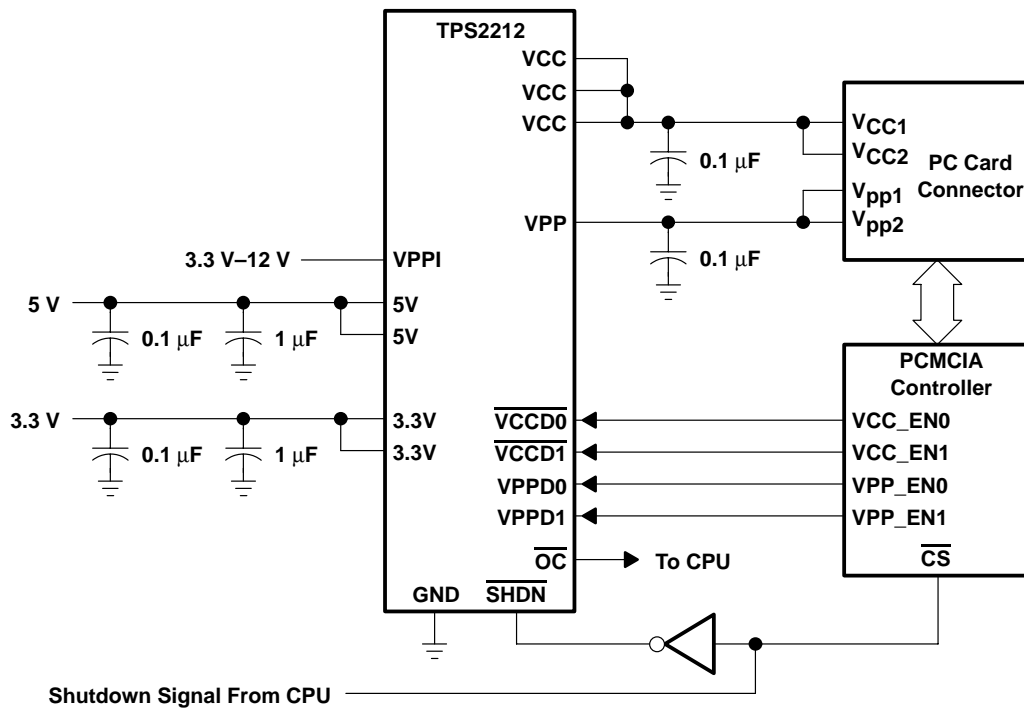

# TPS2212

## SINGLE-SLOT, PARALLEL INTERFACE POWER SWITCH FOR LOW POWER PC CARD SLOTS

SLVS193A – APRIL 1999 – REVISED JANUARY 2001

### Terminal Functions

TERMINAL NAME	NO.	I/O	DESCRIPTION
3.3V	3, 4	I	3.3-V $V_{CC}$ input for card power and/or chip power if 5 V is not present
5V	5, 6	I	5-V $V_{CC}$ input for card power and/or chip power
VPPI	9	I	Main $V_{pp}$ input, typically 12 V, allows 3.3 V–12 V.
VCC	11, 12, 13	O	Switched output that delivers 0 V, 3.3-V, 5-V, or high impedance to card
VPP	10	O	Switched output that delivers 0 V 3.3-V, 5-V, VPPI (12V), or high impedance to card
GND	7		Ground
$\overline{OC}$	8	O	Logic-level overcurrent reporting output that goes low when an overcurrent conditions exists
$\overline{SHDN}$	16	I	Logic input that shuts down the TPS2212 and sets all power outputs to high-impedance state
VCCD0	1	I	Logic input that controls voltage of VCC (see control-logic table)
VCCD1	2	I	Logic input that controls voltage of VCC (see control-logic table)
VPPD0	15	I	Logic input that controls voltage of VPP (see control-logic table)
VPPD1	14	I	Logic input that controls voltage of VPP (see control-logic table)

### absolute maximum ratings over operating free-air temperature (unless otherwise noted)†

Input voltage range for card power:	$V_{I(5V)}$ .....	–0.3 V to 7 V
	$V_{I(3.3V)}$ .....	–0.3 V to 7 V
	$V_{I(VPPI)}$ .....	–0.3 V to 14 V
Logic input voltage .....		–0.3 V to 7 V
Continuous total power dissipation .....		See Dissipation Rating Table
Output current (each card):	$I_{O(VCC)}$ .....	internally limited
	$I_{O(VPP)}$ .....	internally limited
Operating virtual junction temperature range, $T_J$ .....		–40°C to 150°C
Operating free-air temperature range, $T_A$ .....		–40°C to 85°C
Storage temperature range, $T_{stg}$ .....		–55°C to 150°C
Lead temperature 1.6 mm (1/16 inch) from case for 10 seconds .....		260°C

† Stresses beyond those listed under “absolute maximum ratings” may cause permanent damage to the device. These are stress ratings only, and functional operation of the device at these or any other conditions beyond those indicated under “recommended operating conditions” is not implied. Exposure to absolute-maximum-rated conditions for extended periods may affect device reliability.

DISSIPATION RATING TABLE

PACKAGE	$T_A \leq 25^\circ\text{C}$ POWER RATING	DERATING FACTOR ABOVE $T_A = 25^\circ\text{C}$	$T_A = 70^\circ\text{C}$ POWER RATING	$T_A = 85^\circ\text{C}$ POWER RATING
DB	775 mW	6.2 mW/°C	496 mW	403 mW

These devices are mounted on an FR4 board with no special thermal considerations.

### recommended operating conditions

		MIN	MAX	UNIT
Input voltage, $V_I$	$V_{I(5V)}$	0	5.25	V
	$V_{I(3.3V)}$	0	5.25	V
	$V_{I(VPPI)}$	0	13.5	V
Output current	$I_{O(VCC)}$		250	mA
	$I_{O(VPP)}$		150	mA
Operating virtual junction temperature, $T_J$		–40	125	°C



# TPS2212 SINGLE-SLOT, PARALLEL INTERFACE POWER SWITCH FOR LOW POWER PC CARD SLOTS

SLVS193A – APRIL 1999 – REVISED JANUARY 2001

electrical characteristics,  $T_A = -40^{\circ}\text{C}$  to  $85^{\circ}\text{C}$  (unless otherwise noted)

## power switch

PARAMETER		TEST CONDITIONS†	MIN	TYP	MAX	UNIT
Switch resistance	5 V to VCC	$V_{I(5V)} = 5\text{ V}$		160	210	$\text{m}\Omega$
	3.3 V to VCC	$V_{I(5V)} = 5\text{ V}, V_{I(3.3V)} = 3.3\text{ V}$		160	210	
	3.3 V to VCC	$V_{I(5V)} = 0\text{ V}, V_{I(3.3V)} = 3.3\text{ V}$		160	210	
	5 V to VPP	$T_J = 25^{\circ}\text{C}$			6	$\Omega$
	3.3 V to VPP	$T_J = 25^{\circ}\text{C}$			6	
	12 V to VPP	$T_J = 25^{\circ}\text{C}$			1	
$V_{O(VPP)}$	Clamp low voltage	$I_{pp}$ at 10 mA			0.8	V
$V_{O(VCC)}$	Clamp low voltage	$I_{CC}$ at 10 mA			0.8	V
$I_{lkg}$	Leakage current	$I_{pp}$ high-impedance state	$T_A = 25^{\circ}\text{C}$	1	10	$\mu\text{A}$
			$T_A = 85^{\circ}\text{C}$		50	
	$I_{CC}$ high-impedance state	$T_A = 25^{\circ}\text{C}$	1	10		
		$T_A = 85^{\circ}\text{C}$		50		
$I_I$	Input current	$V_{I(5V)} = 5\text{ V}$	$V_{O(VCC)} = 5\text{ V}, V_{O(VPP)} = 12\text{ V}$	40	150	$\mu\text{A}$
		$V_{I(5V)} = 0\text{ V}, V_{I(3.3V)} = 3.3\text{ V}$	$V_{O(VCC)} = 3.3\text{ V}, V_{O(VPP)} = 12\text{ V}$	40	150	
		Shutdown mode	$V_{O(VCC)} = V_{O(VPP)} = \text{Hi-Z}$		1	
$I_{OS}$	Short-circuit output-current limit	$I_{O(VCC)}$	$T_J = 85^{\circ}\text{C}$ , output powered into a short to GND	300	600	$\text{mA}$
		$I_{O(VPP)}$		120	400	$\text{mA}$

† Pulse-testing techniques maintain junction temperature close to ambient temperature; thermal effects must be taken into account separately.

## logic section

PARAMETER		TEST CONDITIONS†	MIN	MAX	UNIT
Logic input current				1	$\mu\text{A}$
Logic input high level			2		V
Logic input low level				0.8	V
Logic output high level		$V_{I(5V)} = 5\text{ V}, I_O = 1\text{ mA}$	$V_{I(5V)} - 0.4$		V
		$V_{I(5V)} = 0\text{ V}, I_O = 1\text{ mA}, V_{I(3.3V)} = 3.3\text{ V}$	$V_{I(3.3V)} - 0.4$		
Logic output low level		$I_O = 1\text{ mA}$		0.4	V

† Pulse-testing techniques maintain junction temperature close to ambient temperature; thermal effects must be taken into account separately.

## switching characteristics‡

PARAMETER		TEST CONDITIONS§	MIN	TYP	MAX	UNIT
$t_r$	Rise times, output	$V_{O(VCC)}$		2.8		ms
		$V_{O(VPP)}$		6.4		
$t_f$	Fall times, output	$V_{O(VCC)}$		4.5		
		$V_{O(VPP)}$		12		
$t_{pd}$	Propagation delay (see Figure1)	$V_{I(VPPD0)}$ to $V_{O(VPP)}$	$t_{on}$	6.8		ms
			$t_{off}$	18		
		$V_{I(VCCD1)}$ to $V_{O(VCC)} (3.3V)$	$t_{on}$	4		
			$t_{off}$	17		
		$V_{I(VCCD0)}$ to $V_{O(VCC)} (5V)$	$t_{on}$	6.6		
			$t_{off}$	17		

‡ Switching Characteristics are with  $C_L = 150\text{ }\mu\text{F}$ .

§ Refer to Parameter Measurement Information



TPS2212  
SINGLE-SLOT, PARALLEL INTERFACE POWER SWITCH  
FOR LOW POWER PC CARD SLOTS

SLVS193A – APRIL 1999 – REVISED JANUARY 2001

**PARAMETER MEASUREMENT INFORMATION**

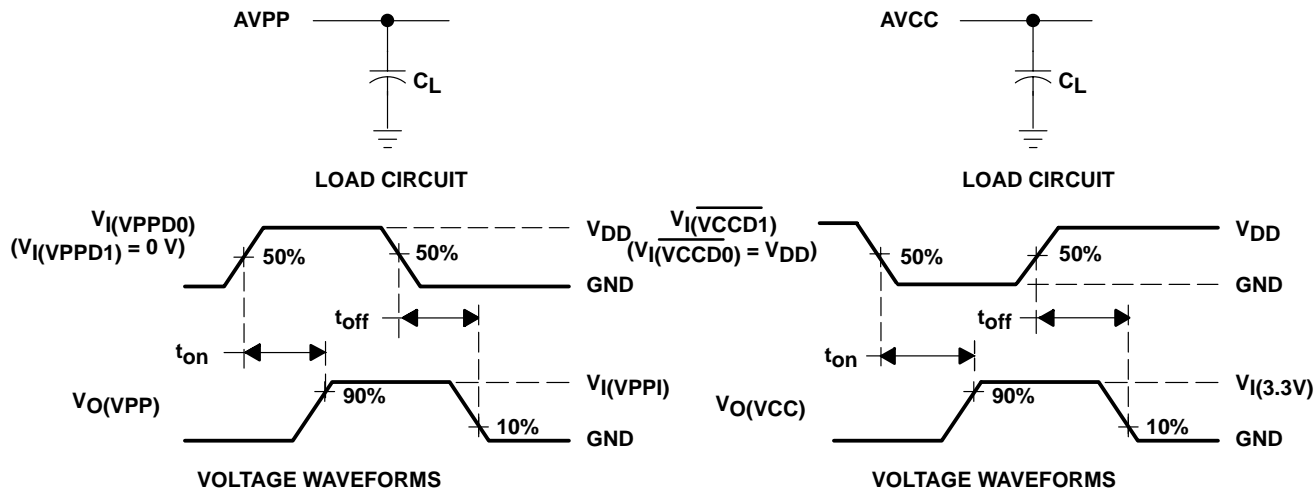

**Figure 1. Test Circuits and Voltage Waveforms**

**Table of Timing Diagrams**

	FIGURE
VCC Propagation Delay and Rise Time With 1- $\mu$ F Load, 3.3-V Switch	2
VCC Propagation Delay and Fall Time With 1- $\mu$ F Load, 3.3-V Switch	3
VCC Propagation Delay and Rise Time With 150- $\mu$ F Load, 3.3-V Switch	4
VCC Propagation Delay and Fall Time With 150- $\mu$ F Load, 3.3-V Switch	5
VCC Propagation Delay and Rise Time With 1- $\mu$ F Load, 5-V Switch	6
VCC Propagation Delay and Fall Time With 1- $\mu$ F Load, 5-V Switch	7
VCC Propagation Delay and Rise Time With 150- $\mu$ F Load, 5-V Switch	8
VCC Propagation Delay and Fall Time With 150- $\mu$ F Load, 5-V Switch	9
VPP Propagation Delay and Rise Time With 1- $\mu$ F Load, 12-V Switch	10
VPP Propagation Delay and Fall Time With 1- $\mu$ F Load, 12-V Switch	11
VPP Propagation Delay and Rise Time With 150- $\mu$ F Load, 12-V Switch	12
VPP Propagation Delay and Fall Time With 150- $\mu$ F Load, 12-V Switch	13

**TPS2212**  
**SINGLE-SLOT, PARALLEL INTERFACE POWER SWITCH**  
**FOR LOW POWER PC CARD SLOTS**

SLVS193A – APRIL 1999 – REVISED JANUARY 2001

**PARAMETER MEASUREMENT INFORMATION**

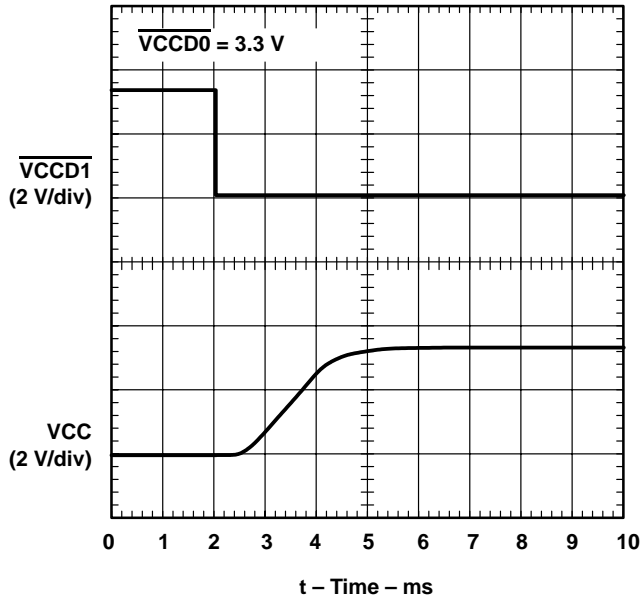

**Figure 2. VCC Propagation Delay and Rise Time With 1- $\mu$ F Load, 3.3-V Switch**

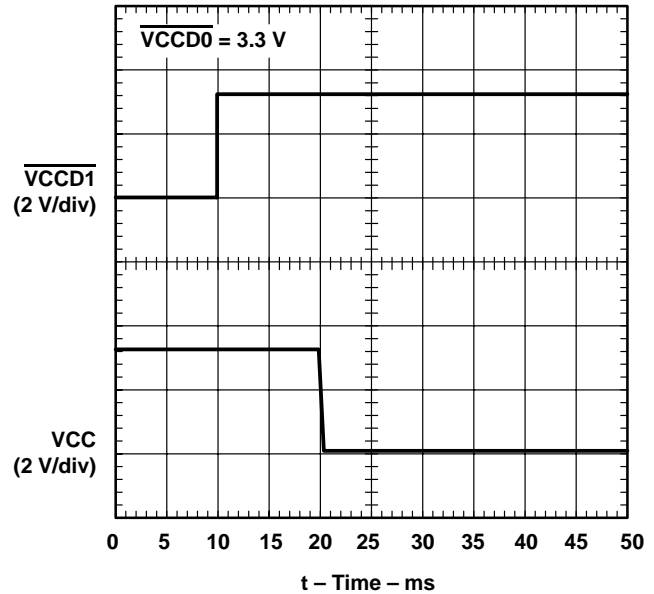

**Figure 3. VCC Propagation Delay and Fall Time With 1- $\mu$ F Load, 3.3-V Switch**

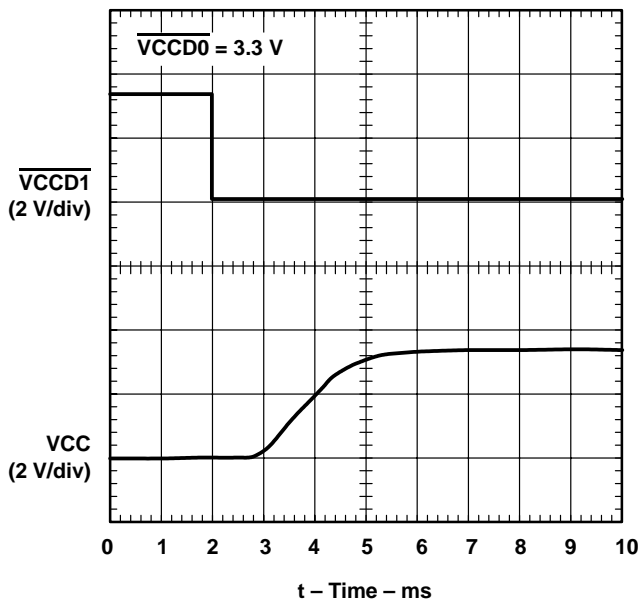

**Figure 4. VCC Propagation Delay and Rise Time With 150- $\mu$ F Load, 3.3-V Switch**

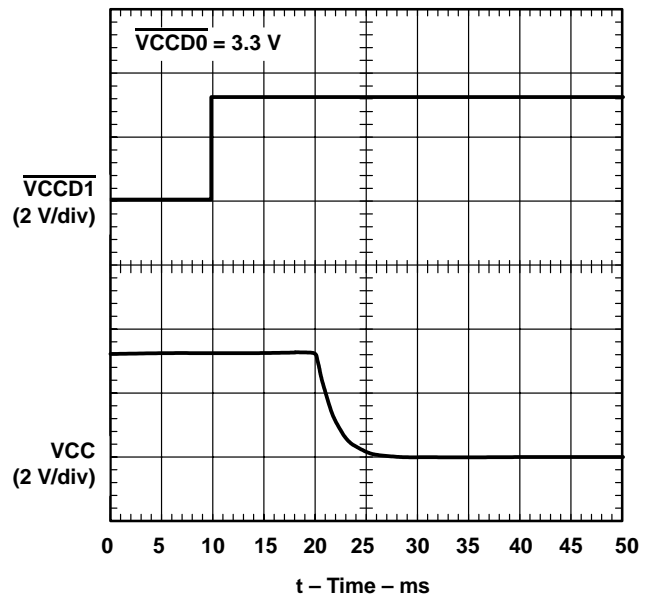

**Figure 5. VCC Propagation Delay and Fall Time With 150- $\mu$ F Load, 3.3-V Switch**



**PARAMETER MEASUREMENT INFORMATION**

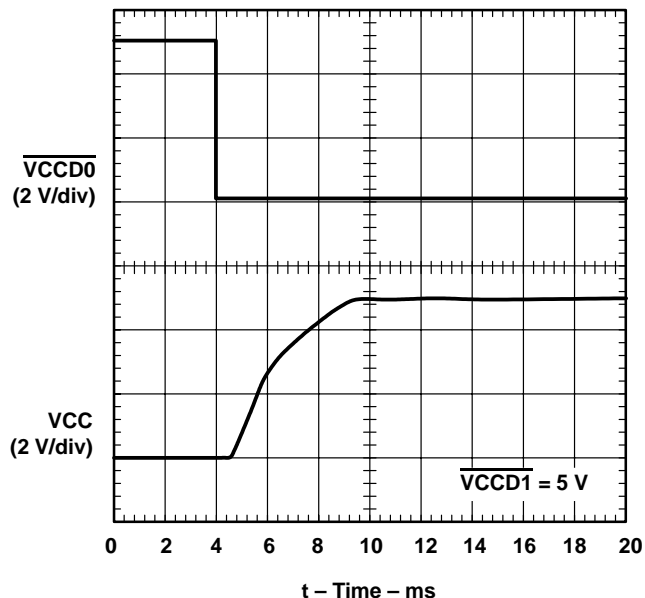

**Figure 6. VCC Propagation Delay and Rise Time With 1- $\mu$ F Load, 5-V Switch**

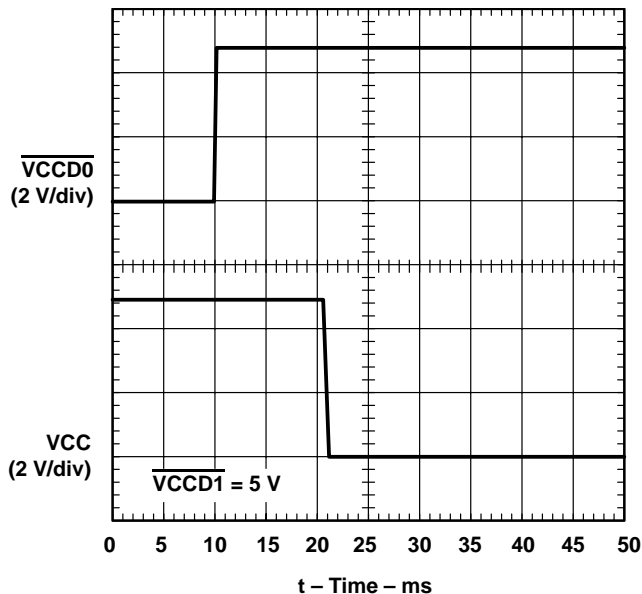

**Figure 7. VCC Propagation Delay and Fall Time With 1- $\mu$ F Load, 5-V Switch**

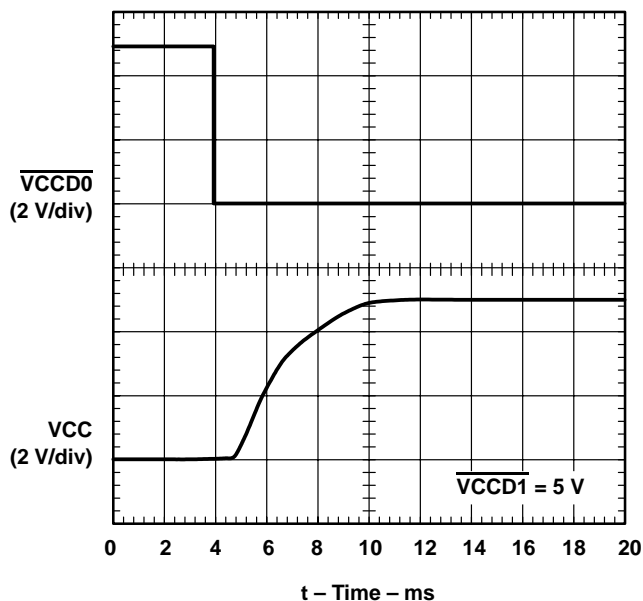

**Figure 8. VCC Propagation Delay and Rise Time With 150- $\mu$ F Load, 5-V Switch**

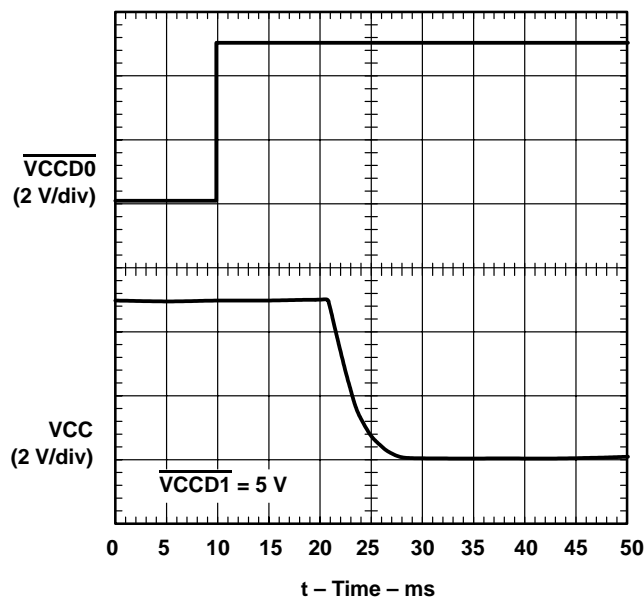
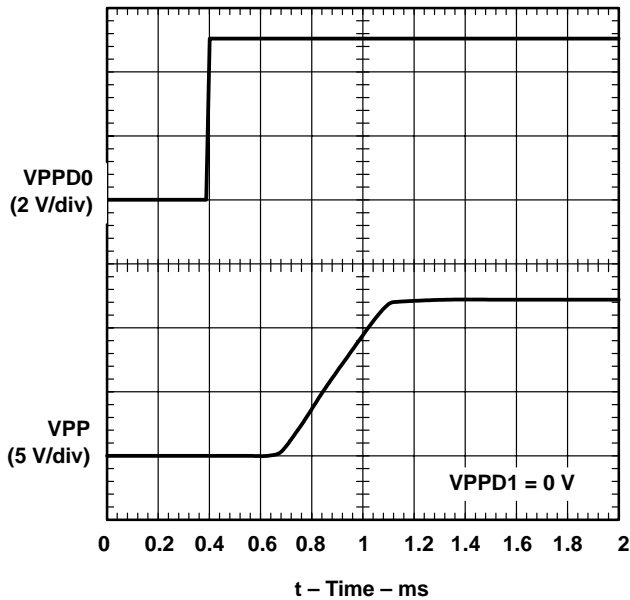

**Figure 9. VCC Propagation Delay and Fall Time With 150- $\mu$ F Load, 5-V Switch**

**TPS2212**  
**SINGLE-SLOT, PARALLEL INTERFACE POWER SWITCH**  
**FOR LOW POWER PC CARD SLOTS**

SLVS193A – APRIL 1999 – REVISED JANUARY 2001

**PARAMETER MEASUREMENT INFORMATION**



**Figure 10. VPP Propagation Delay and Rise Time With 1- $\mu$ F Load, 12-V Switch**

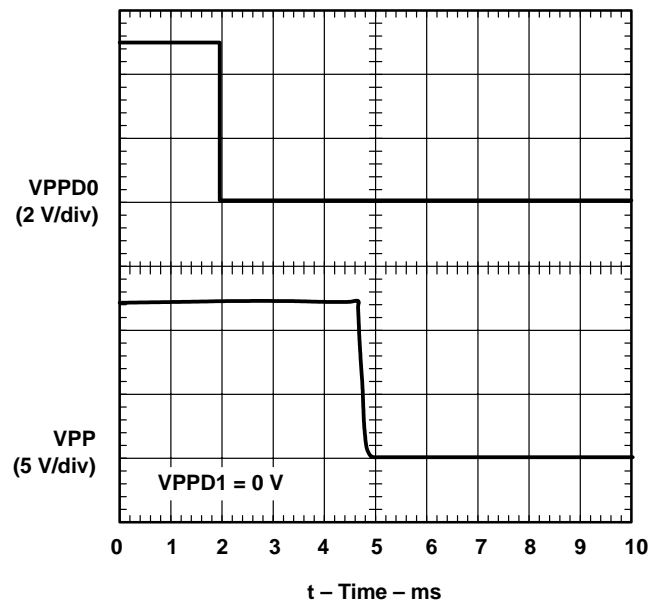

**Figure 11. VPP Propagation Delay and Fall Time With 1- $\mu$ F Load, 12-V Switch**

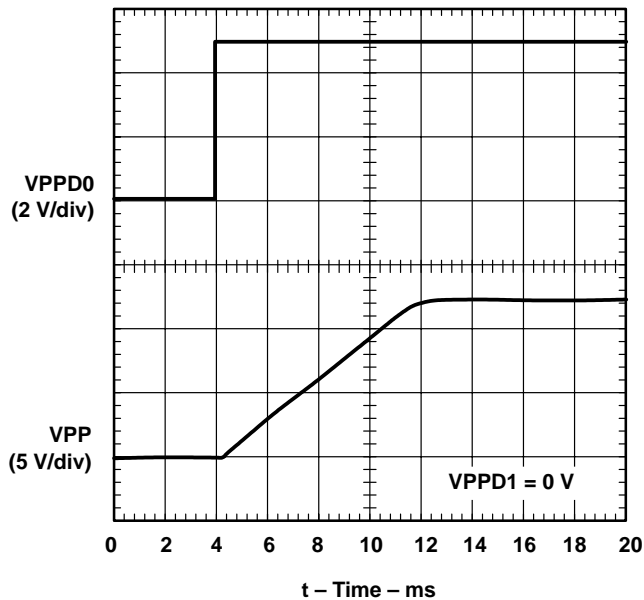

**Figure 12. VPP Propagation Delay and Rise Time With 150- $\mu$ F Load, 12-V Switch**

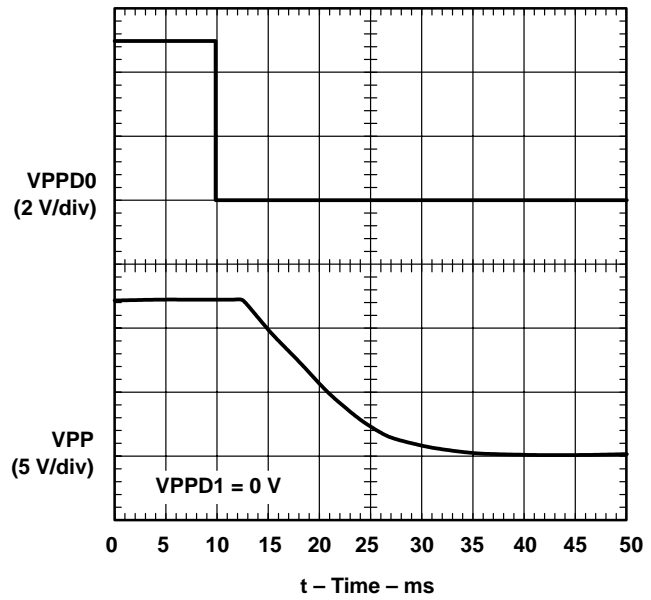

**Figure 13. VPP Propagation Delay and Fall Time With 150- $\mu$ F Load, 12-V Switch**



**TPS2212**  
**SINGLE-SLOT, PARALLEL INTERFACE POWER SWITCH**  
**FOR LOW POWER PC CARD SLOTS**

SLVS193A – APRIL 1999 – REVISED JANUARY 2001

**TYPICAL CHARACTERISTICS**

**Table of Graphs**

			<b>FIGURE</b>
$I_{CC}(5V)$	Supply current	vs Junction Temperature	14
$I_{CC}(3.3V)$	Supply current	vs Junction Temperature	15
$r_{DS(on)}$	Static drain-source on-state resistance, 5-V VCC switch	vs Junction Temperature	16
$r_{DS(on)}$	Static drain-source on-state resistance, 3.3-V VCC switch	vs Junction Temperature	17
$r_{DS(on)}$	Static drain-source on-state resistance, 12-V VPP switch	vs Junction Temperature	18
$V_O(VCC)$	Output voltage, 5-V VCC switch	vs Output current	19
$V_O(VCC)$	Output voltage, 3.3-V VCC switch	vs Output current	20
$V_O(VPP)$	Output voltage, 12-V VPP switch	vs Output current	21
$I_{OS}(VCC)$	Short-circuit current, 5-V VCC switch	vs Junction Temperature	22
$I_{OS}(VCC)$	Short-circuit current, 3.3-V VCC switch	vs Junction Temperature	23
$I_{OS}(VPP)$	Short-circuit current, 12-V VPP switch	vs Junction Temperature	24

**TPS2212**  
**SINGLE-SLOT, PARALLEL INTERFACE POWER SWITCH**  
**FOR LOW POWER PC CARD SLOTS**

SLVS193A – APRIL 1999 – REVISED JANUARY 2001

**TYPICAL CHARACTERISTICS**

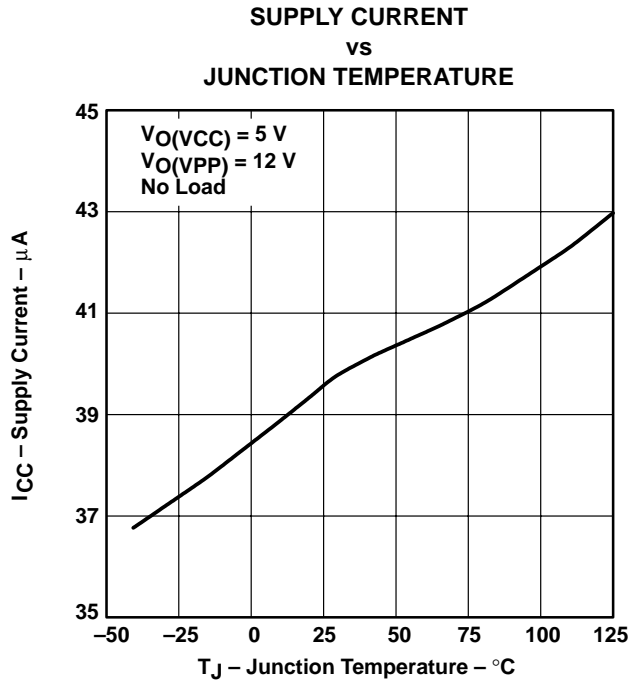

**Figure 14**

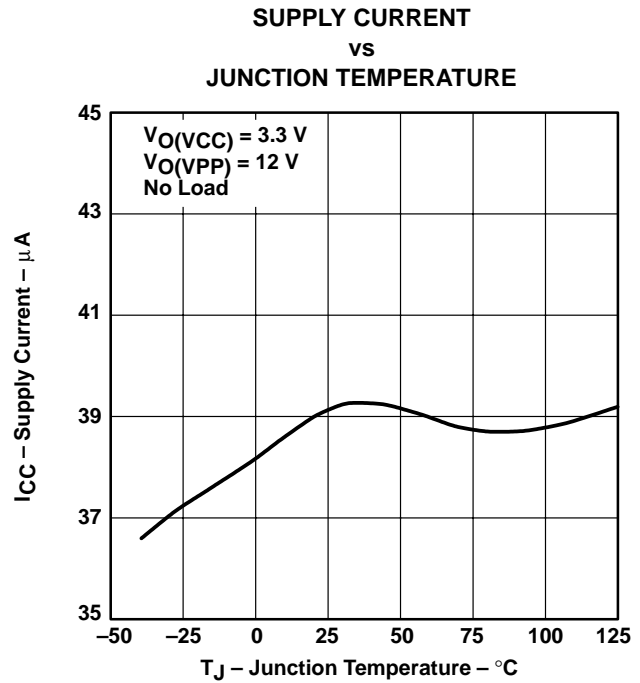

**Figure 15**

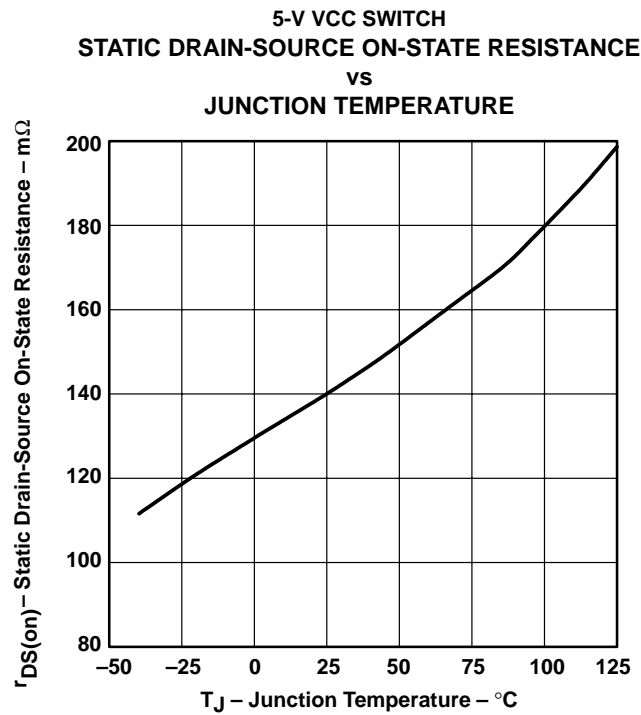

**Figure 16**

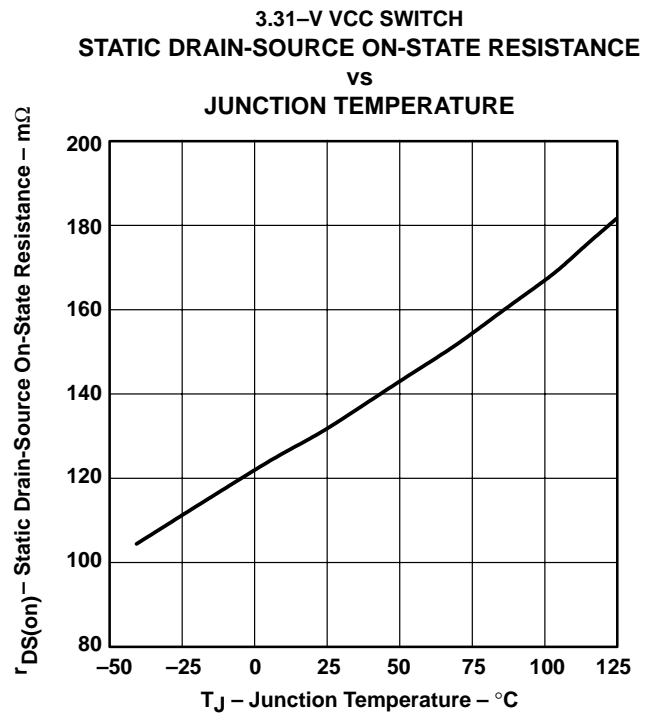

**Figure 17**



**TPS2212**  
**SINGLE-SLOT, PARALLEL INTERFACE POWER SWITCH**  
**FOR LOW POWER PC CARD SLOTS**

SLVS193A – APRIL 1999 – REVISED JANUARY 2001

**TYPICAL CHARACTERISTICS**

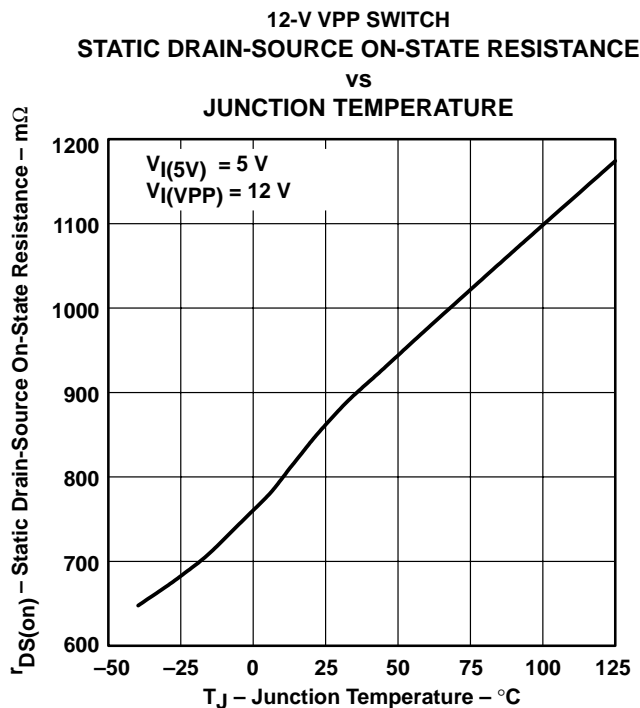

Figure 18

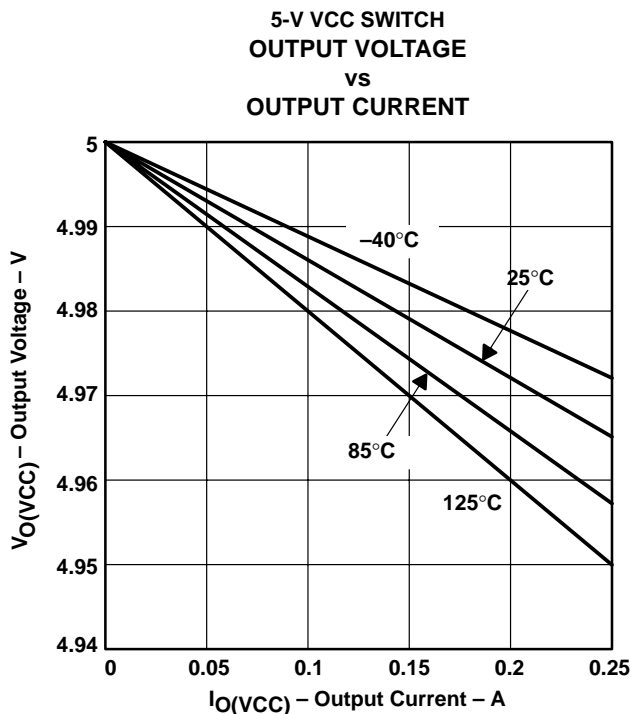

Figure 19

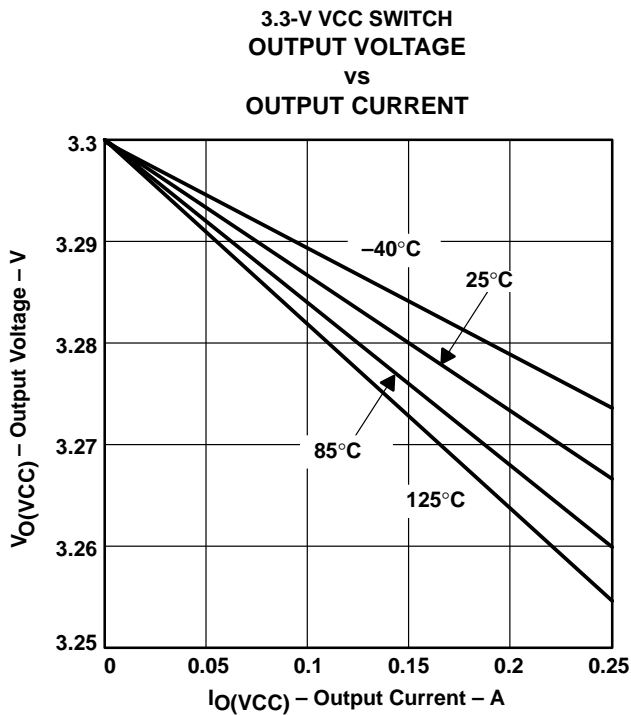

Figure 20

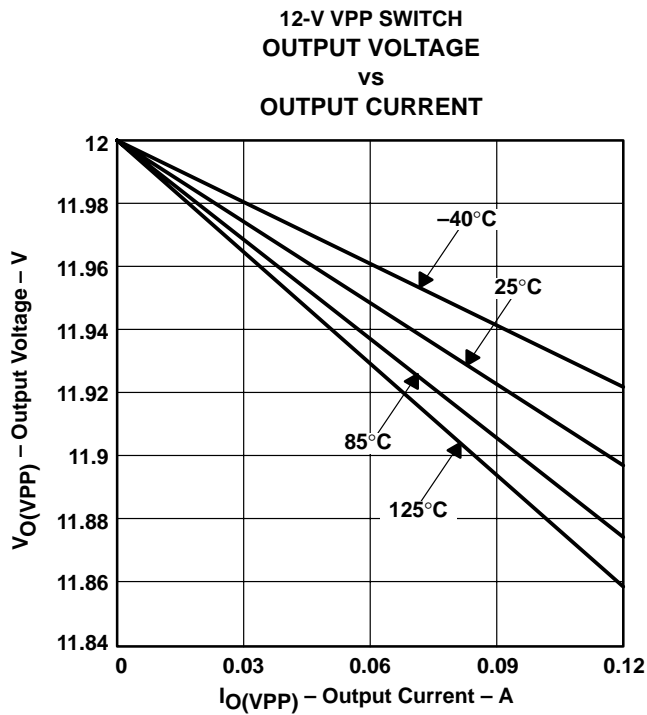

Figure 21



**TPS2212**  
**SINGLE-SLOT, PARALLEL INTERFACE POWER SWITCH**  
**FOR LOW POWER PC CARD SLOTS**

SLVS193A – APRIL 1999 – REVISED JANUARY 2001

**TYPICAL CHARACTERISTICS**

**5-V VCC SWITCH**  
**SHORT-CIRCUIT CURRENT**  
**vs**  
**JUNCTION TEMPERATURE**

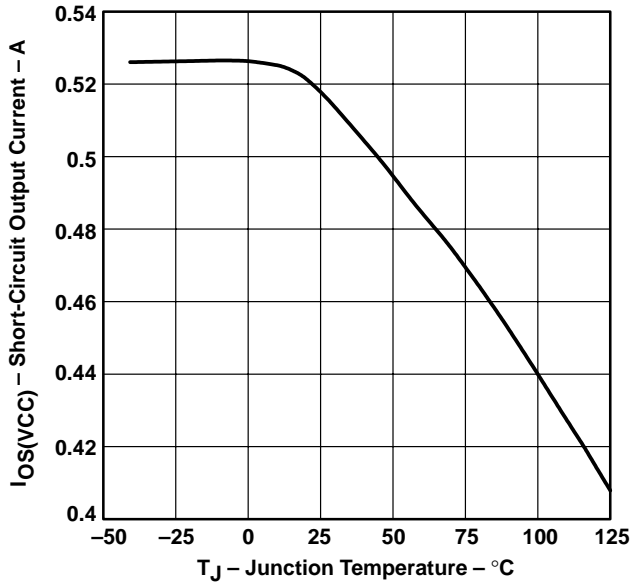

**Figure 22**

**3.3-V VCC SWITCH**  
**SHORT-CIRCUIT CURRENT**  
**vs**  
**JUNCTION TEMPERATURE**

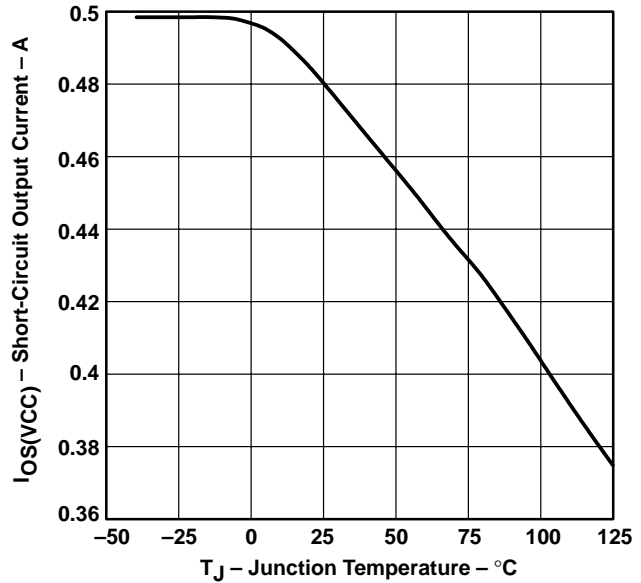

**Figure 23**

**12-V VPP SWITCH**  
**SHORT-CIRCUIT CURRENT**  
**vs**  
**JUNCTION TEMPERATURE**

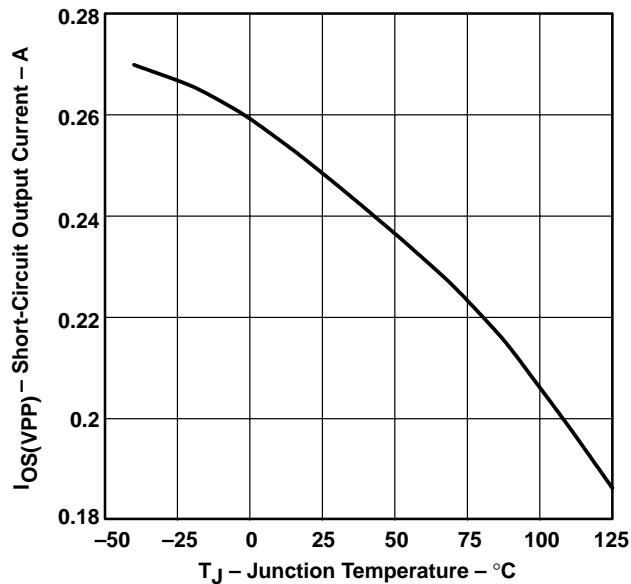

**Figure 24**



## APPLICATION INFORMATION

### overview

PC Cards were initially introduced as a means to add EEPROM (flash memory) to portable computers with limited on-board memory. The idea of add-in cards quickly took hold; modems, wireless LANs, GPS systems, multimedia, and hard-disk versions were soon available. As the number of PC Card applications grew, the engineering community quickly recognized the need for a standard to ensure compatibility across platforms. To this end, the PCMCIA (Personal Computer Memory Card International Association) was established, comprised of members from leading computer, software, PC Card, and semiconductor manufacturers. One key goal was to realize the *plug-and-play* concept, i.e. cards and hosts from different vendors should be compatible.

### PC Card power specification

System compatibility also means power compatibility. The most current set of specifications (PC Card Standard) set forth by the PCMCIA committee states that power is to be transferred between the host and the card through eight of the 68 terminals of the PC Card connectors. This power interface consists of two VCC, two VPP, and four ground terminals. Multiple VCC and ground terminals minimize connector-terminal and line resistance. The two VPP terminals were originally specified as separate signals, but are commonly tied together in the host to form a single node to minimize voltage losses. Card primary power is supplied through the VCC terminals; flash-memory programming and erase voltage is supplied through the VPP terminals.

### designing for voltage regulation

The current PCMCIA specification for output voltage regulation of the 5-V output is 5% (250 mV). In a typical PC power-system design, the power supply will have an output voltage regulation ( $V_{PS(\text{reg})}$ ) of 2% (100 mV). Also, a voltage drop from the power supply to the PC Card will result from resistive losses ( $V_{PCB}$ ) in the PCB traces and the PCMCIA connector. A typical design would limit the total of these resistive losses to less than 1% (50 mV) of the output voltage. Therefore the allowable voltage drop ( $V_{DS}$ ) for the TPS2212 is the PCMCIA voltage regulation less the power supply regulation and less the PCB and connector resistive drops:

$$V_{DS} = V_{O(\text{reg})} - V_{PS(\text{reg})} - V_{PCB}$$

Typically, this would leave 100 mV for the allowable voltage drop across the TPS2212. The voltage drop is the output current multiplied by the switch resistance of the TPS2212. Therefore, the maximum output current that can be delivered to the PC Card in regulation is the allowable voltage drop across the TPS2212 divided by the output switch resistance.

$$I_{O\text{max}} = \frac{V_{DS}}{r_{DS(\text{on})}}$$

The VCC outputs deliver 250 mA continuous at 5 V and 3.3 V within regulation over the operating temperature range. Using the same equations, the PCMCIA specification for output voltage regulation of the 3.3 V output is 300 mV. Using the voltage drop percentages for power supply regulation (2%) and PCB resistive loss (1%), the allowable voltage drop for the 3.3 V switch is 200 mV. The 12-V outputs (VPP) of the TPS2212 can deliver 150 mA continuously.

# TPS2212

## SINGLE-SLOT, PARALLEL INTERFACE POWER SWITCH FOR LOW POWER PC CARD SLOTS

SLVS193A – APRIL 1999 – REVISED JANUARY 2001

---

### APPLICATION INFORMATION

#### overcurrent and overtemperature protection

PC Cards are inherently subject to damage from mishandling. Host systems require protection against short-circuited cards that could lead to power supply or PCB trace damage. Even systems sufficiently robust to withstand a short circuit would still undergo rapid battery discharge into the damaged PC Card, resulting in a sudden loss of system power. Most hosts include fuses for protection. The reliability of fused systems is poor and requires troubleshooting and repair, usually by the manufacturer, when fuses are blown.

The TPS2212 uses sense FETs to check for overcurrent conditions in each of the VCC and VPP outputs. Unlike sense resistors or polyfuses, these FETs do not add to the series resistance of the switch; therefore voltage and power losses are reduced. Overcurrent sensing is applied to each output separately. When an overcurrent condition is detected, only the power output affected is limited; all other power outputs continue to function normally. The  $\overline{OC}$  indicator, normally a logic high, is a logic low when an overcurrent condition is detected providing for initiation of system diagnostics and/or sending a warning message to the user.

During power up, the TPS2212 controls the rise time of the VCC and VPP outputs and limits the current into a faulty card or connector. If a short circuit is applied after power is established (e.g., hot insertion of a bad card), current is initially limited only by the impedance between the short and the power supply. In extreme cases, as much as 5 A to 10 A may flow into the short before the current limiting of the TPS2212 engages. If the VCC or VPP outputs are driven below ground, the TPS2212 may latch nondestructively in an off state. Cycling power will reestablish normal operation.

Overcurrent limiting for the VCC outputs is designed to activate if powered up into a short in the range of 300 mA to 600 mA, typically at about 450 mA. The VPP outputs limit from 120 mA to 400 mA, typically around 280 mA. The protection circuitry acts by linearly limiting the current passing through the switch rather than initiating a full shutdown of the supply. Shutdown occurs only during thermal limiting.

Thermal limiting prevents destruction of the IC from overheating if the package power dissipation ratings are exceeded. Thermal limiting disables power output until the device has cooled.

#### 12-V supply not required

Most PC Card switches use the externally supplied 12 V to power gate drive and other chip functions, which requires that power be present at all times. The TPS2212 offers considerable power savings by using an internal charge pump to generate the required higher voltages from the 5-V input. Therefore, the external 12-V supply can be disabled except when needed for flash-memory functions, thereby extending battery lifetime. Do not ground the VPPI switch input when the VPPI input is not used. Additional power savings are realized by the TPS2212 during a software shutdown in which quiescent current drops to a maximum of 1  $\mu$ A.

#### 3.3-V low-voltage mode

The TPS2212 will operate in a 3.3-V low-voltage mode when 3.3 V is the only available input voltage ( $V_{I(5V)} = 0$ ). This allows host and PC Cards to be operated in low-power 3.3-volts-only modes such as sleep or pager modes. Note that in these operation modes, the TPS2212 will derive its bias current from the 3.3-V input pin and only 3.3 V can be delivered to the PC Card.



POST OFFICE BOX 655303 • DALLAS, TEXAS 75265

## APPLICATION INFORMATION

### voltage transitioning requirement

PC Cards are migrating from 5 V to 3.3 V to minimize power consumption, optimize board space, and increase logic speeds. The TPS2212 meets all combinations of power delivery as currently defined in the PCMCIA standard. The latest protocol accommodates mixed 3.3-V/5-V systems by first powering the card with 5 V, then polling it to determine its 3.3-V compatibility. The PCMCIA specification requires that the capacitors on 3.3-V compatible cards be discharged to below 0.8 V before applying 3.3-V power. This functions as a power reset and ensures that sensitive 3.3-V circuitry is not subjected to any residual 5-V charge. The TPS2212 offers a selectable VCC and VPP ground state, in accordance with PCMCIA 3.3-V/5-V switching specifications.

### output ground switches

PC Card specification requires that  $V_{CC}$  be discharged within 100 ms. PC Card resistance can not be relied on to provide a discharge path for voltages stored on PC Card capacitance because of possible high-impedance isolation by power-management schemes.

### power-supply considerations

The TPS2212 has multiple pins for each of its 3.3-V and 5-V power inputs and for the switched VCC outputs. Any individual pin can conduct the rated input or output current. Unless all pins are connected in parallel, the series resistance is significantly higher than that specified, resulting in increased voltage drops and lost power. It is recommended that all input and output power pins be paralleled for optimum operation.

To increase the noise immunity of the TPS2212, the power supply inputs should be bypassed with a 1- $\mu$ F electrolytic or tantalum capacitor paralleled by a 0.047- $\mu$ F to 0.1- $\mu$ F ceramic capacitor. It is strongly recommended that the switched outputs be bypassed with a 0.1- $\mu$ F, or larger, ceramic capacitor; doing so improves the immunity of the TPS2212 to electrostatic discharge (ESD). Care should be taken to minimize the inductance of PCB traces between the TPS2212 and the load. High switching currents can produce large negative voltage transients, which forward biases substrate diodes, resulting in unpredictable performance. Similarly, no pin should be taken below  $-0.3$  V.

### calculating junction temperature

The switch resistance,  $r_{DS(on)}$ , is dependent on the junction temperature,  $T_J$ , of the die and the current through the switch. To calculate  $T_J$ , first find  $r_{DS(on)}$  from Figures 16 through 18 using an initial temperature estimate about 50°C above ambient. Then calculate the power dissipation for each switch, using the formula:

$$P_D = r_{DS(on)} \times I^2$$

Next, sum the power dissipation and calculate the junction temperature:

$$T_J = \left( \sum P_D \times R_{\theta JA} \right) + T_A, \quad R_{\theta JA} = 108^\circ\text{C/W}$$

Compare the calculated junction temperature with the initial temperature estimate. If the temperatures are not within a few degrees of each other, recalculate using the calculated temperature as the initial estimate.

# TPS2212 SINGLE-SLOT, PARALLEL INTERFACE POWER SWITCH FOR LOW POWER PC CARD SLOTS

SLVS193A – APRIL 1999 – REVISED JANUARY 2001

## APPLICATION INFORMATION

### ESD protection

All TPS2212 inputs and outputs incorporate ESD-protection circuitry designed to withstand a 2-kV human-body-model discharge as defined in MIL-STD-883C, Method 3015. The VCC and VPP outputs can be exposed to potentially higher discharges from the external environment through the PC Card connector. Bypassing the outputs with 0.1- $\mu$ F capacitors protects the devices from discharges up to 10 kV.

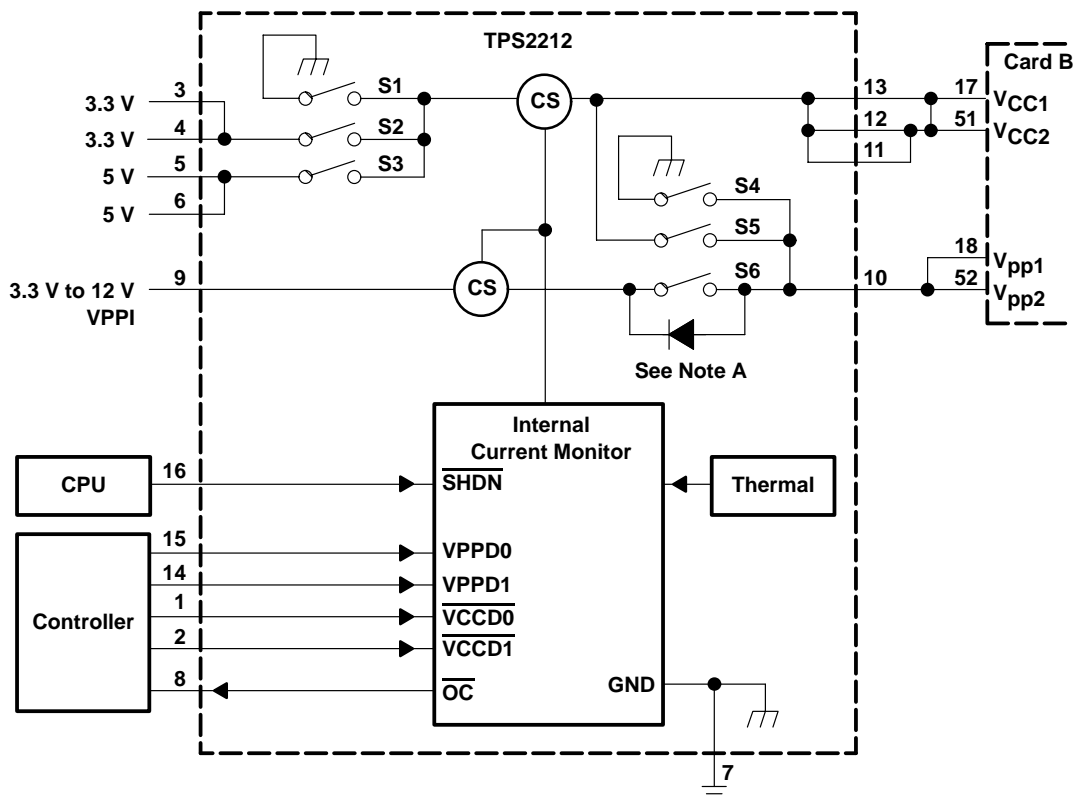

NOTE A: MOSFET switch S6 has a back-gate diode from the source to the drain. Unused switch inputs should never be grounded.

Figure 25. Internal Switching Matrix, TPS2212 Control Logic



TPS2212  
**SINGLE-SLOT, PARALLEL INTERFACE POWER SWITCH  
 FOR LOW POWER PC CARD SLOTS**

SLVS193A – APRIL 1999 – REVISED JANUARY 2001

**APPLICATION INFORMATION**

**TPS2212 control logic**

**VPP**

CONTROL SIGNALS			INTERNAL SWITCH SETTINGS			OUTPUT
SHDN	VPPD0	VPPD1	S4	S5	S6	VPP
1	0	0	CLOSED	OPEN	OPEN	0 V
1	0	1	OPEN	CLOSED	OPEN	VCC†
1	1	0	OPEN	OPEN	CLOSED	VPP1
1	1	1	OPEN	OPEN	OPEN	Hi-Z
0	X	X	OPEN	OPEN	OPEN	Hi-Z

† Output depends on AVCC

**VCC**

CONTROL SIGNALS			INTERNAL SWITCH SETTINGS			OUTPUT
SHDN	VCCD1	VCCD0	S1	S2	S3	VCC
1	0	0	CLOSED	OPEN	OPEN	0 V
1	0	1	OPEN	CLOSED	OPEN	3.3 V
1	1	0	OPEN	OPEN	CLOSED	5 V
1	1	1	CLOSED	OPEN	OPEN	0 V
0	X	X	OPEN	OPEN	OPEN	Hi-Z

# TPS2212 SINGLE-SLOT, PARALLEL INTERFACE POWER SWITCH FOR LOW POWER PC CARD SLOTS

SLVS193A – APRIL 1999 – REVISED JANUARY 2001

## APPLICATION INFORMATION

### 12-V flash memory supply

The TPS6734 is a fixed 12-V output boost converter capable of delivering 120 mA from inputs as low as 2.7 V. The device is pin-for-pin compatible with the MAX734 regulator and offers the following advantages: lower supply current, wider operating input-voltage range, and higher output currents. As shown in Figure 26, the only external components required are: an inductor, a Schottky rectifier, an output filter capacitor, an input filter capacitor, and a small capacitor for loop compensation. The entire converter occupies less than 0.7 in<sup>2</sup> of PCB space when implemented with surface-mount components. An enable input is provided to shut the converter down and reduce the supply current to 3  $\mu$ A when 12 V is not needed.

The TPS6734 is a 170-kHz current-mode PWM (pulse-width modulation) controller with an n-channel MOSFET power switch. Gate drive for the switch is derived from the 12-V output after start-up to minimize the die area needed to realize the 0.7- $\Omega$  MOSFET and improve efficiency at input voltages below 5 V. Soft start is accomplished with the addition of one small capacitor. A 1.22-V reference (pin 2) is brought out for external use. For additional information, see the TPS6734 data sheet (SLVS127).

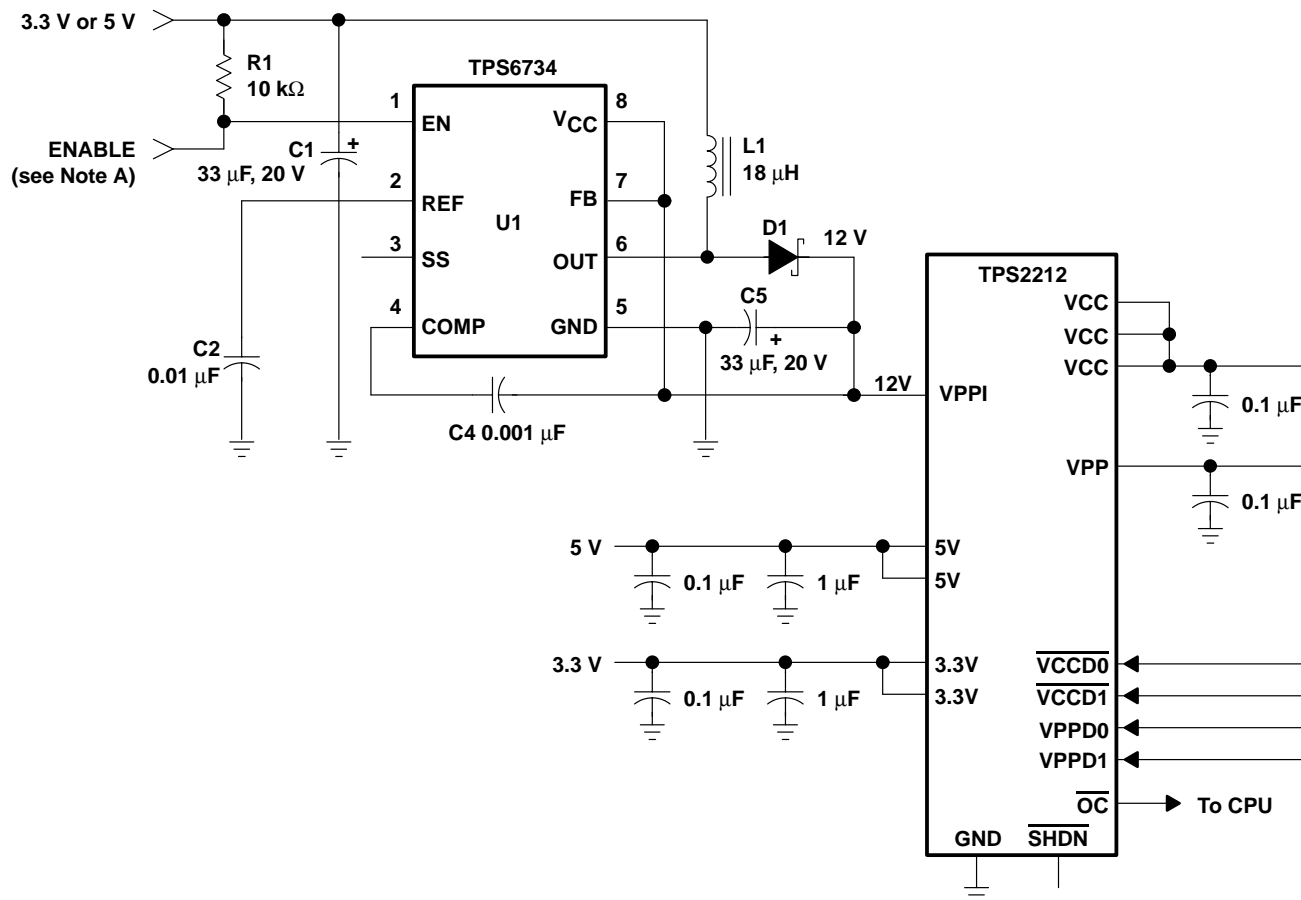

NOTE A: The enable terminal can be tied to a general purpose I/O terminal on the PCMCIA controller or tied high.

Figure 26. TPS2212 With TPS6734 12-V, 120-mA Supply

**TPS2212**  
**SINGLE-SLOT, PARALLEL INTERFACE POWER SWITCH**  
**FOR LOW POWER PC CARD SLOTS**

SLVS193A – APRIL 1999 – REVISED JANUARY 2001

**MECHANICAL DATA**

**DB (R-PDSO-G\*\*)**

**PLASTIC SMALL-OUTLINE PACKAGE**

28 PIN SHOWN

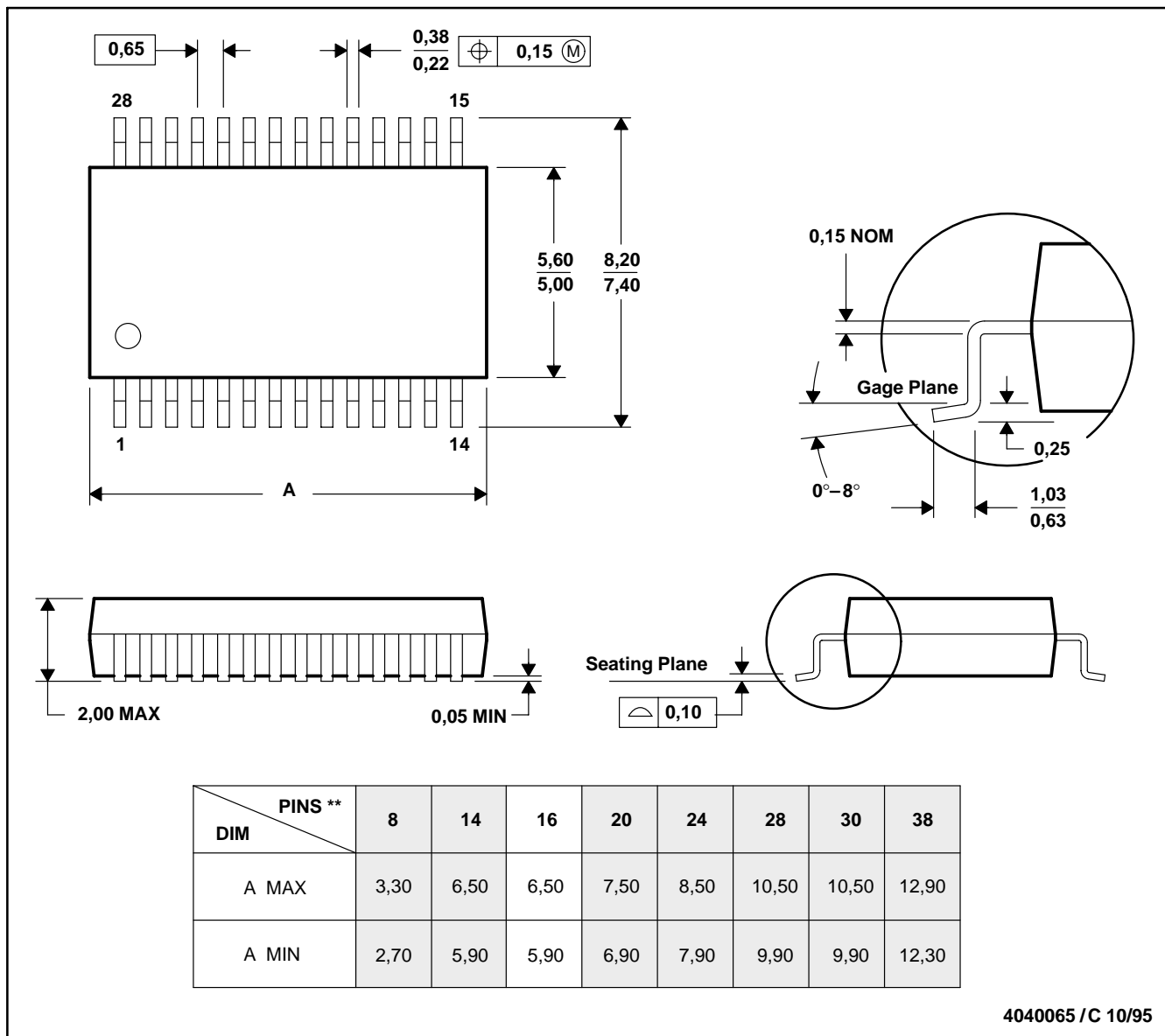

- NOTES: A. All linear dimensions are in millimeters.  
 B. This drawing is subject to change without notice.  
 C. Body dimensions do not include mold flash or protrusion not to exceed 0,15.  
 D. Falls within JEDEC MO-150

**PACKAGING INFORMATION**

Orderable part number	Status (1)	Material type (2)	Package   Pins	Package qty   Carrier	RoHS (3)	Lead finish/ Ball material (4)	MSL rating/ Peak reflow (5)	Op temp (°C)	Part marking (6)
<a href="#">TPS2212IDB</a>	Active	Production	SSOP (DB)   16	80   TUBE	Yes	NIPDAU	Level-1-260C-UNLIM	-40 to 85	PU2212
TPS2212IDB.A	Active	Production	SSOP (DB)   16	80   TUBE	Yes	NIPDAU	Level-1-260C-UNLIM	-40 to 85	PU2212
TPS2212IDBG4	Active	Production	SSOP (DB)   16	80   TUBE	Yes	NIPDAU	Level-1-260C-UNLIM	-40 to 85	PU2212

**(1) Status:** For more details on status, see our [product life cycle](#).

**(2) Material type:** When designated, preproduction parts are prototypes/experimental devices, and are not yet approved or released for full production. Testing and final process, including without limitation quality assurance, reliability performance testing, and/or process qualification, may not yet be complete, and this item is subject to further changes or possible discontinuation. If available for ordering, purchases will be subject to an additional waiver at checkout, and are intended for early internal evaluation purposes only. These items are sold without warranties of any kind.

**(3) RoHS values:** Yes, No, RoHS Exempt. See the [TI RoHS Statement](#) for additional information and value definition.

**(4) Lead finish/Ball material:** Parts may have multiple material finish options. Finish options are separated by a vertical ruled line. Lead finish/Ball material values may wrap to two lines if the finish value exceeds the maximum column width.

**(5) MSL rating/Peak reflow:** The moisture sensitivity level ratings and peak solder (reflow) temperatures. In the event that a part has multiple moisture sensitivity ratings, only the lowest level per JEDEC standards is shown. Refer to the shipping label for the actual reflow temperature that will be used to mount the part to the printed circuit board.

**(6) Part marking:** There may be an additional marking, which relates to the logo, the lot trace code information, or the environmental category of the part.

Multiple part markings will be inside parentheses. Only one part marking contained in parentheses and separated by a "-" will appear on a part. If a line is indented then it is a continuation of the previous line and the two combined represent the entire part marking for that device.

**Important Information and Disclaimer:** The information provided on this page represents TI's knowledge and belief as of the date that it is provided. TI bases its knowledge and belief on information provided by third parties, and makes no representation or warranty as to the accuracy of such information. Efforts are underway to better integrate information from third parties. TI has taken and continues to take reasonable steps to provide representative and accurate information but may not have conducted destructive testing or chemical analysis on incoming materials and chemicals. TI and TI suppliers consider certain information to be proprietary, and thus CAS numbers and other limited information may not be available for release.

In no event shall TI's liability arising out of such information exceed the total purchase price of the TI part(s) at issue in this document sold by TI to Customer on an annual basis.

**TUBE**

\*All dimensions are nominal

Device	Package Name	Package Type	Pins	SPQ	L (mm)	W (mm)	T (μm)	B (mm)
TPS2212IDB	DB	SSOP	16	80	530	10.5	4000	4.1
TPS2212IDB.A	DB	SSOP	16	80	530	10.5	4000	4.1
TPS2212IDBG4	DB	SSOP	16	80	530	10.5	4000	4.1

## IMPORTANT NOTICE AND DISCLAIMER

TI PROVIDES TECHNICAL AND RELIABILITY DATA (INCLUDING DATASHEETS), DESIGN RESOURCES (INCLUDING REFERENCE DESIGNS), APPLICATION OR OTHER DESIGN ADVICE, WEB TOOLS, SAFETY INFORMATION, AND OTHER RESOURCES "AS IS" AND WITH ALL FAULTS, AND DISCLAIMS ALL WARRANTIES, EXPRESS AND IMPLIED, INCLUDING WITHOUT LIMITATION ANY IMPLIED WARRANTIES OF MERCHANTABILITY, FITNESS FOR A PARTICULAR PURPOSE OR NON-INFRINGEMENT OF THIRD PARTY INTELLECTUAL PROPERTY RIGHTS.

These resources are intended for skilled developers designing with TI products. You are solely responsible for (1) selecting the appropriate TI products for your application, (2) designing, validating and testing your application, and (3) ensuring your application meets applicable standards, and any other safety, security, regulatory or other requirements.

These resources are subject to change without notice. TI grants you permission to use these resources only for development of an application that uses the TI products described in the resource. Other reproduction and display of these resources is prohibited. No license is granted to any other TI intellectual property right or to any third party intellectual property right. TI disclaims responsibility for, and you fully indemnify TI and its representatives against any claims, damages, costs, losses, and liabilities arising out of your use of these resources.

TI's products are provided subject to [TI's Terms of Sale](#), [TI's General Quality Guidelines](#), or other applicable terms available either on [ti.com](#) or provided in conjunction with such TI products. TI's provision of these resources does not expand or otherwise alter TI's applicable warranties or warranty disclaimers for TI products. Unless TI explicitly designates a product as custom or customer-specified, TI products are standard, catalog, general purpose devices.

TI objects to and rejects any additional or different terms you may propose.

Copyright © 2025, Texas Instruments Incorporated

Last updated 10/2025