

# TPS22971 具备可调节快速接通电源和电源正常的 3.6V, 3A, 6.7mΩ 导通阻抗负载开关

## 1 特性

- 输入电压范围 ( $V_{IN}$ ): 0.65V 至 3.6V
- 导通电阻
  - $R_{ON} = 6.7m\Omega$  ( $V_{IN} \geq 1.8V$  时的典型值)
  - $R_{ON} = 7.2m\Omega$  ( $V_{IN} = 1.05V$  时的典型值)
  - $R_{ON} = 8.9m\Omega$  ( $V_{IN} = 0.65V$  时的典型值)
- 最大持续开关电流 ( $I_{MAX}$ ): 3A
- 导通状态 ( $I_Q$ ): 30 $\mu$ A (3.6  $V_{IN}$  时的典型值)
- 断开状态 ( $I_{SD}$ ): 1 $\mu$ A (3.6  $V_{IN}$  时的典型值)
- 通过 CT 引脚的可调节转换率
  - 在  $V_{IN} = 1V$  时, 快速接通电源时间  $\leq 65\mu$ s
- 打开开关后的电源正常 (PG) 指示器
- 低阈值启用 (ON) 0.9V ( $V_{IH}$ ) 支持使用低电压控制逻辑单元
- 热关断 ( $T_{SD}$ )
- 快速输出放电 (QOD): 150 $\Omega$  (典型值)

## 2 应用

- 笔记本电脑, 平板电脑
- 工业 PC
- 智能手机
- 电信
- 存储

## 3 说明

TPS22971 是一款节省空间的单通道负载开关, 具有受控和可调节的接通转换率和集成的电源正常指示器。该器件包括一个 N 通道金属氧化物半导体场效应晶体管 (MOSFET), 可在 0.65V 至 3.6V 的低输入电压范围内运行, 可支持 3A 的最大持续电流。6.7m $\Omega$  的低导通电阻可最大限度降低功耗和整个负载开关的压降。开关可由一个打开和关闭输入 (ON) 控制, 此输入可与低压控制信号直接连接。

默认情况下, TPS22971 有快速打开时间, 以最大程度减少系统启动和等待时间。也可以减小可调节转换率以限制浪涌电流。电源正常 (PG) 信号在内部监控栅极阈值, 并指示开关何时完全接通电源。禁用开关时, 一个 150 $\Omega$  的片上电阻可快速将输出电压对地放电, 防止其浮动。

TPS22971 采用超小型节省空间的 8 引脚 WCSP 封装, 可在  $-40^{\circ}C$  至  $105^{\circ}C$  的大气温度范围内运作, 并集成了热关断和关闭功能, 以防过热。

器件信息(1)

器件型号	封装	封装尺寸 (标称值)
TPS22971	DSBGA (8)	1.90mm x 0.90mm

(1) 如需了解所有可用封装, 请参阅数据表末尾的可订购产品附录。

典型应用

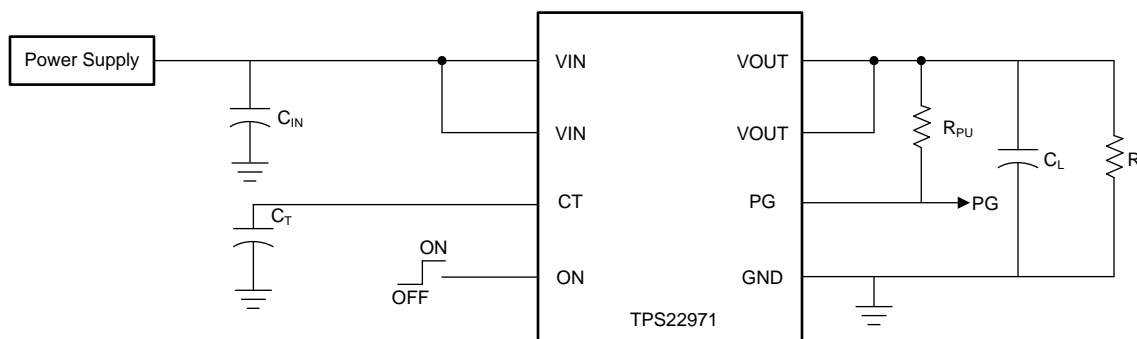

Copyright © 2017, Texas Instruments Incorporated



## 目录

<p><b>1 特性</b> ..... 1</p> <p><b>2 应用</b> ..... 1</p> <p><b>3 说明</b> ..... 1</p> <p><b>4 修订历史记录</b> ..... 2</p> <p><b>5 Pin Configuration and Functions</b> ..... 3</p> <p><b>6 Specifications</b> ..... 4</p> <p>    6.1 Absolute Maximum Ratings ..... 4</p> <p>    6.2 ESD Ratings ..... 4</p> <p>    6.3 Recommended Operating Conditions ..... 4</p> <p>    6.4 Thermal Information ..... 4</p> <p>    6.5 Electrical Characteristics ..... 5</p> <p>    6.6 Switching Characteristics ..... 6</p> <p>    6.7 Typical DC Characteristics ..... 7</p> <p>    6.8 Typical AC Characteristics ..... 7</p> <p><b>7 Parameter Measurement Information</b> ..... 11</p> <p><b>8 Detailed Description</b> ..... 12</p> <p>    8.1 Overview ..... 12</p> <p>    8.2 Functional Block Diagram ..... 12</p>	<p>    8.3 Feature Description ..... 12</p> <p>    8.4 Device Functional Modes ..... 14</p> <p><b>9 Application and Implementation</b> ..... 15</p> <p>    9.1 Application Information ..... 15</p> <p>    9.2 Typical Application ..... 17</p> <p><b>10 Power Supply Recommendations</b> ..... 19</p> <p><b>11 Layout</b> ..... 19</p> <p>    11.1 Layout Guidelines ..... 19</p> <p>    11.2 Layout Example ..... 19</p> <p><b>12 器件和文档支持</b> ..... 20</p> <p>    12.1 文档支持 ..... 20</p> <p>    12.2 接收文档更新通知 ..... 20</p> <p>    12.3 社区资源 ..... 20</p> <p>    12.4 商标 ..... 20</p> <p>    12.5 静电放电警告 ..... 20</p> <p>    12.6 Glossary ..... 20</p> <p><b>13 机械、封装和可订购信息</b> ..... 20</p>
--	--

## 4 修订历史记录

Changes from Original (April 2017) to Revision A	Page
<ul style="list-style-type: none"> <li>• 已更改 将器件状态从“高级信息”更改为“生产数据” ..... 1</li> </ul>	1
Changes from Revision A (July 2017) to Revision B	Page
<ul style="list-style-type: none"> <li>• 已删除 从器件信息表的器件型号中删除了 YZPT ..... 1</li> <li>• 已更改 将特性部分中的 1.1<math>\mu</math>A 更改成了 1<math>\mu</math>A ..... 1</li> <li>• 已删除 删除了重复封装图 ..... 1</li> </ul>	1

## 5 Pin Configuration and Functions

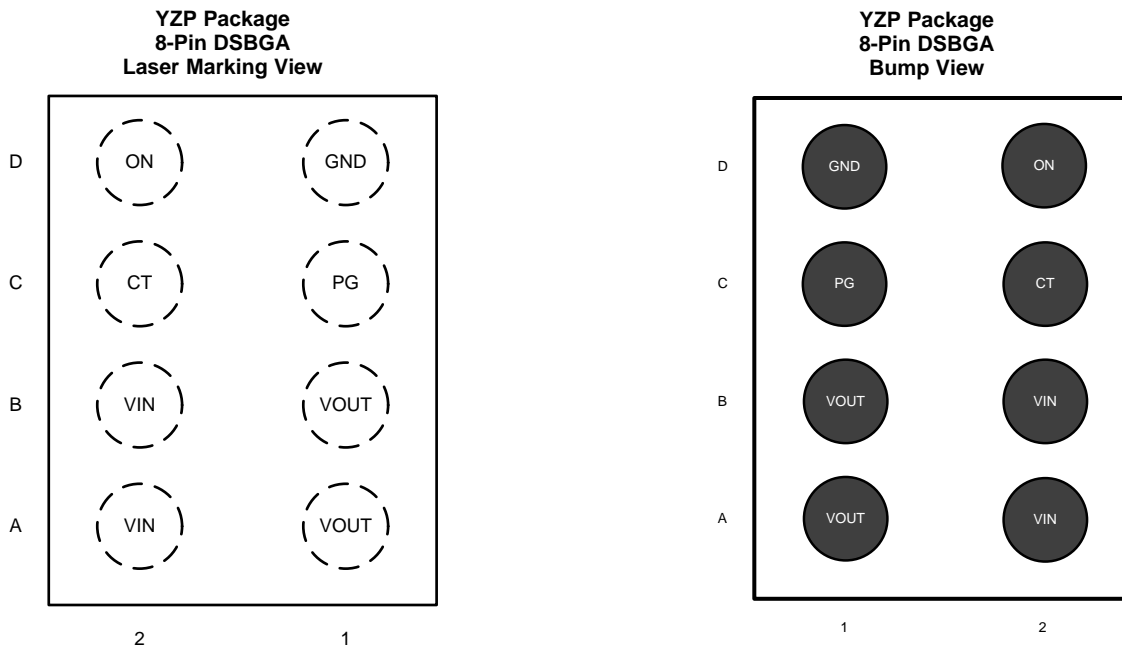

### Pin Functions

PIN		I/O	DESCRIPTION
NAME	NO.		
CT	C2	O	VOUT slew rate control. Adding capacitance from this pin to ground lowers the output slew rate
GND	D1	GND	Ground
ON	D2	I	Switch enable control input. Do not leave floating
PG	C1	O	Power Good Indication. Open drain releases when the switch is fully on
VOUT	A1, B1	O	Switch output
VIN	A2, B2	I	Switch input

## 6 Specifications

### 6.1 Absolute Maximum Ratings

Over operating free-air temperature range (unless otherwise noted)<sup>(1)</sup>

		MIN	MAX	UNIT
V <sub>IN</sub>	Input voltage	-0.3	4	V
V <sub>OUT</sub>	Output voltage	-0.3	4	V
V <sub>ON</sub>	ON voltage	-0.3	4	V
V <sub>PG</sub>	PG voltage	-0.3	4	V
I <sub>MAX</sub>	Maximum continuous switch current		3	A
I <sub>PLS</sub>	Maximum pulsed switch current, pulse < 300-μs, 2% duty cycle		4	A
T <sub>J</sub>	Maximum junction temperature	Internally Limited		
T <sub>stg</sub>	Storage temperature	-65	150	°C

- (1) Stresses beyond those listed under *Absolute Maximum Ratings* may cause permanent damage to the device. These are stress ratings only, which do not imply functional operation of the device at these or any other conditions beyond those indicated under *Recommended Operating Conditions*. Exposure to absolute-maximum-rated conditions for extended periods may affect device reliability.

### 6.2 ESD Ratings

		VALUE	UNIT
V <sub>(ESD)</sub>	Electrostatic discharge	Human-body model (HBM), per ANSI/ESDA/JEDEC JS-001 <sup>(1)</sup>	±2000
		Charged-device model (CDM), per JEDEC specification JESD22-C101 <sup>(2)</sup>	±1000

- (1) JEDEC document JEP155 states that 500-V HBM allows safe manufacturing with a standard ESD control process.  
 (2) JEDEC document JEP157 states that 250-V CDM allows safe manufacturing with a standard ESD control process.

### 6.3 Recommended Operating Conditions

over operating free-air temperature range (unless otherwise noted)

		MIN	MAX	UNIT
V <sub>IN</sub>	Input voltage	0.65	3.6	V
V <sub>OUT</sub>	Output voltage		V <sub>IN</sub>	V
V <sub>IH</sub>	High-level input voltage, ON	0.9	3.6	V
V <sub>IL</sub>	Low-level input voltage, ON	0	0.45	V
T <sub>J</sub>	Operating temperature	-40	125	°C
T <sub>A</sub>	Operating free-air temperature	-40	105	°C
C <sub>T</sub>	CT pin capacitor voltage rating	7		V

### 6.4 Thermal Information

THERMAL METRIC <sup>(1)</sup>		TPS22971	UNIT
		YZP (DSBGA)	
		8 PINS	
R <sub>θJA</sub>	Junction-to-ambient thermal resistance	130	°C/W
R <sub>θJC(top)</sub>	Junction-to-case (top) thermal resistance	54	°C/W
R <sub>θJB</sub>	Junction-to-board thermal resistance	51	°C/W
ψ <sub>JT</sub>	Junction-to-top characterization parameter	1	°C/W
ψ <sub>JB</sub>	Junction-to-board characterization parameter	50	°C/W

- (1) For more information about traditional and new thermal metrics, see the [Semiconductor and IC Package Thermal Metrics](#) application report.

## 6.5 Electrical Characteristics

Unless otherwise noted,  $V_{IN} = 0.65\text{ V}$  to  $3.6\text{ V}$

PARAMETER		TEST CONDITIONS		$T_A$	MIN	TYP	MAX	UNIT
$I_Q$	Quiescent current	$V_{OUT} = \text{Open}$ , Switch enabled	$V_{IN} > 1.2\text{ V}$	$-40^\circ\text{C}$ to $+85^\circ\text{C}$	30	65	$\mu\text{A}$	
				$-40^\circ\text{C}$ to $+105^\circ\text{C}$		75		
			$V_{IN} \leq 1.2\text{ V}$	$-40^\circ\text{C}$ to $+85^\circ\text{C}$	20	50		
				$-40^\circ\text{C}$ to $+105^\circ\text{C}$		55		
$I_{SD}$	Shutdown current	$V_{OUT} = \text{GND}$ , Switch disabled	$V_{IN} > 1.8\text{ V}$	$-40^\circ\text{C}$ to $+85^\circ\text{C}$	1	7.5	$\mu\text{A}$	
				$-40^\circ\text{C}$ to $+105^\circ\text{C}$		18		
			$V_{IN} \leq 1.8\text{ V}$	$-40^\circ\text{C}$ to $+85^\circ\text{C}$	0.9	5.5		
				$-40^\circ\text{C}$ to $+105^\circ\text{C}$		9.5		
$R_{ON}$	ON-resistance	$I_{OUT} = -200\text{ mA}$	$V_{IN} \geq 1.8\text{ V}$	$25^\circ\text{C}$	6.7	10	$\text{m}\Omega$	
				$-40^\circ\text{C}$ to $+85^\circ\text{C}$		12		
				$-40^\circ\text{C}$ to $+105^\circ\text{C}$		12		
			$V_{IN} = 1.2\text{ V}$	$25^\circ\text{C}$	6.9	10		
				$-40^\circ\text{C}$ to $+85^\circ\text{C}$		12		
				$-40^\circ\text{C}$ to $+105^\circ\text{C}$		13		
			$V_{IN} = 1.05\text{ V}$	$25^\circ\text{C}$	7.2	10.5		
				$-40^\circ\text{C}$ to $+85^\circ\text{C}$		13		
				$-40^\circ\text{C}$ to $+105^\circ\text{C}$		14		
			$V_{IN} = 0.65\text{ V}$	$25^\circ\text{C}$	8.9	14		
				$-40^\circ\text{C}$ to $+85^\circ\text{C}$		18		
				$-40^\circ\text{C}$ to $+105^\circ\text{C}$		19		
$R_{PD}$	Output pull down resistance <sup>(1)</sup>	$I_{OUT} = 3\text{ mA}$ , Switch disabled	$V_{IN} = 3.6\text{ V}$	$-40^\circ\text{C}$ to $+105^\circ\text{C}$	150		$\Omega$	
			$V_{IN} = 0.65\text{ V}$	$-40^\circ\text{C}$ to $+105^\circ\text{C}$	710		$\Omega$	
$I_{ON}$	ON input leakage current	$V_{ON} = 0\text{ V}$ to $3.6\text{ V}$		$-40^\circ\text{C}$ to $+105^\circ\text{C}$		0.1	$\mu\text{A}$	
$I_{PG,LK}$	Leakage current into PG pin	$V_{PG} = 0\text{ V}$ to $3.6\text{ V}$	$V_{ON} \leq V_{IL}$	$-40^\circ\text{C}$ to $+105^\circ\text{C}$	0.1	8.5	$\mu\text{A}$	
$V_{PG,OL}$	PG output low voltage	$V_{PG} = 0\text{ V}$ to $3.6\text{ V}$	$V_{ON} \geq V_{IH}$ , $I_{PG} = 1\text{ mA}$	$-40^\circ\text{C}$ to $+105^\circ\text{C}$		0.2	V	
$T_{SD}$	Thermal shutdown	$T_J$ rising			170		$^\circ\text{C}$	
$T_{SD,HYS}$	Thermal shutdown hysteresis	$T_J$ falling			30		$^\circ\text{C}$	

(1) See the [Quick Output Discharge \(QOD\)](#) section.

## 6.6 Switching Characteristics

All typical values are at 25°C unless otherwise noted

PARAMETER		TEST CONDITIONS	MIN	TYP	MAX	UNIT
<b>V<sub>IN</sub> = 3.6 V</b>						
t <sub>ON</sub>	Turn-On time	C <sub>T</sub> = 0 pF		54		μs
		C <sub>T</sub> = 1000 pF		198		
		C <sub>T</sub> = 10000 pF		1520		
t <sub>R</sub>	VOUT Rise time	C <sub>T</sub> = 0 pF		35		
		C <sub>T</sub> = 1000 pF		150		
		C <sub>T</sub> = 10000 pF		1230		
t <sub>PG,ON</sub>	PG Turn-On time	C <sub>T</sub> = 0 pF		134		
		C <sub>T</sub> = 1000 pF		314		
		C <sub>T</sub> = 10000 pF		1990		
t <sub>PG,OFF</sub>	PG Turn-Off time			1.9		
t <sub>OFF</sub>	Turn-Off time			3.5		
t <sub>F</sub>	VOUT Fall time	C <sub>L</sub> = 0.1 μF, R <sub>L</sub> = 10 Ω		2.1		
<b>V<sub>IN</sub> = 1.8 V</b>						
t <sub>ON</sub>	Turn-On time	C <sub>T</sub> = 0 pF		41		μs
		C <sub>T</sub> = 1000 pF		126		
		C <sub>T</sub> = 10000 pF		857		
t <sub>R</sub>	VOUT Rise time	C <sub>T</sub> = 0 pF		21		
		C <sub>T</sub> = 1000 pF		82		
		C <sub>T</sub> = 10000 pF		628		
t <sub>PG,ON</sub>	PG Turn-On time	C <sub>T</sub> = 0 pF		105		
		C <sub>T</sub> = 1000 pF		220		
		C <sub>T</sub> = 10000 pF		1230		
t <sub>PG,OFF</sub>	PG Turn-Off time			0.8		
t <sub>OFF</sub>	Turn-Off time			4.8		
t <sub>F</sub>	VOUT Fall time	C <sub>L</sub> = 0.1 μF, R <sub>L</sub> = 10 Ω		2.1		
<b>V<sub>IN</sub> = 0.65 V</b>						
t <sub>ON</sub>	Turn-On time	C <sub>T</sub> = 0 pF		54		μs
		C <sub>T</sub> = 1000 pF		127		
		C <sub>T</sub> = 10000 pF		720		
t <sub>R</sub>	VOUT Rise time	C <sub>T</sub> = 0 pF		21		
		C <sub>T</sub> = 1000 pF		61		
		C <sub>T</sub> = 10000 pF		386		
t <sub>PG,ON</sub>	PG Turn-On time	C <sub>T</sub> = 0 pF		165		
		C <sub>T</sub> = 1000 pF		290		
		C <sub>T</sub> = 10000 pF		1290		
t <sub>PG,OFF</sub>	PG Turn-Off time			0.5		
t <sub>OFF</sub>	Turn-Off time			55		
t <sub>F</sub>	VOUT Fall time	C <sub>L</sub> = 0.1 μF, R <sub>L</sub> = 10 Ω		8		
<b>V<sub>IN</sub> = 1 V, T<sub>A</sub> = 0°C to 85°C</b>						
t <sub>ON</sub>	Fast Turn-On time	C <sub>T</sub> = 0 pF		30	65	μs

### 6.7 Typical DC Characteristics



图 1. Quiescent Current vs Temperature



图 2. Input Shutdown Current vs Temperature

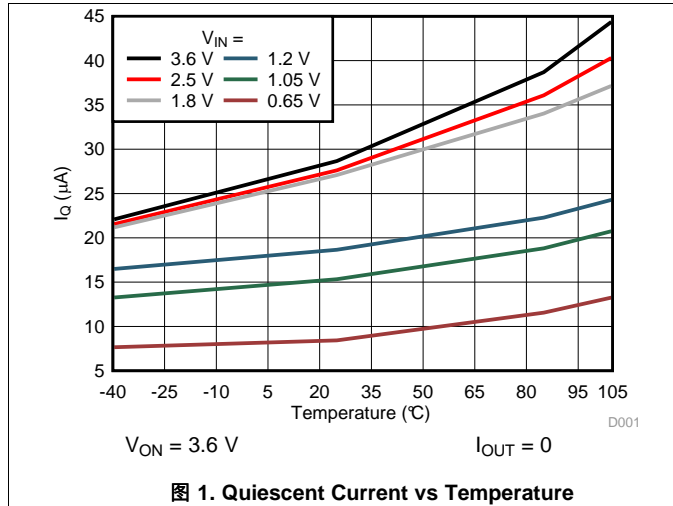

图 3. On-Resistance vs Temperature

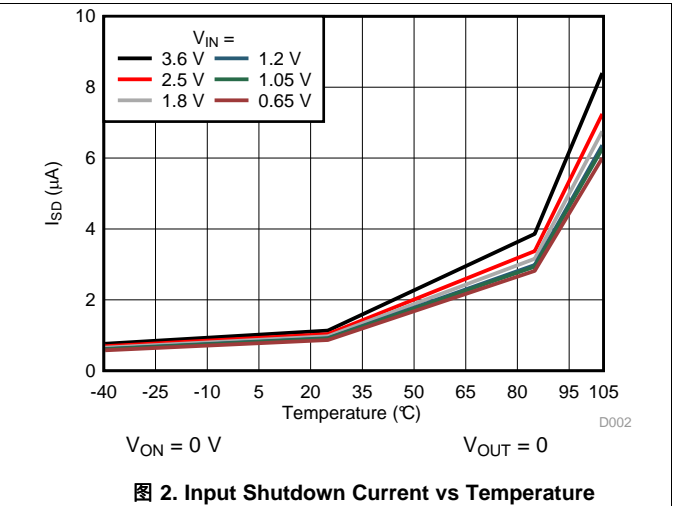

图 4. Output Pull-Down Resistance vs Temperature

### 6.8 Typical AC Characteristics

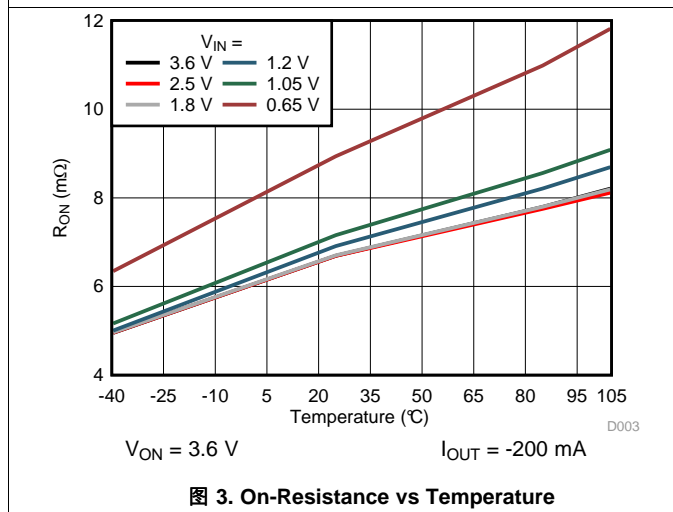

图 5. Turn-On Time vs Temperature

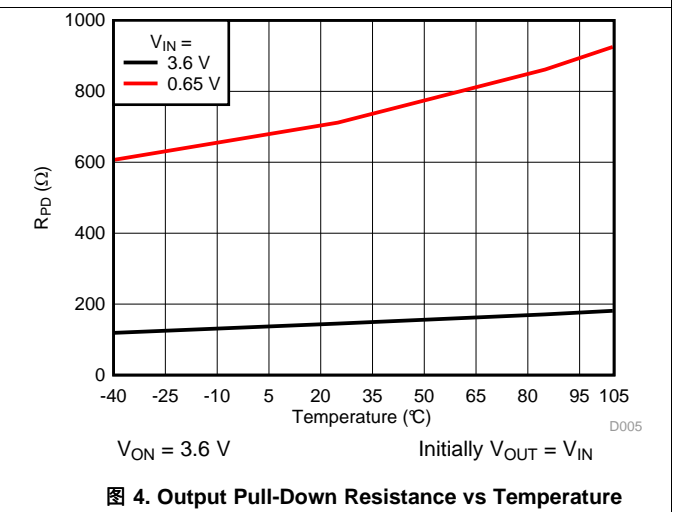

图 6. Fast Turn-On Time vs Temperature

Typical AC Characteristics (接下页)

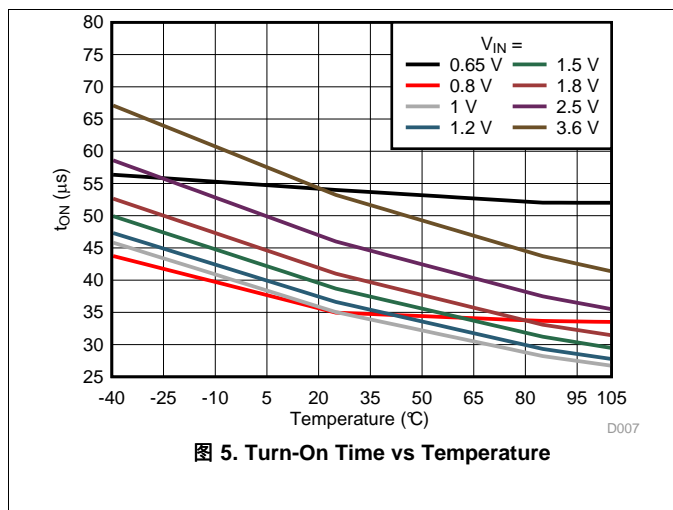

图 7. Rise Time vs Temperature

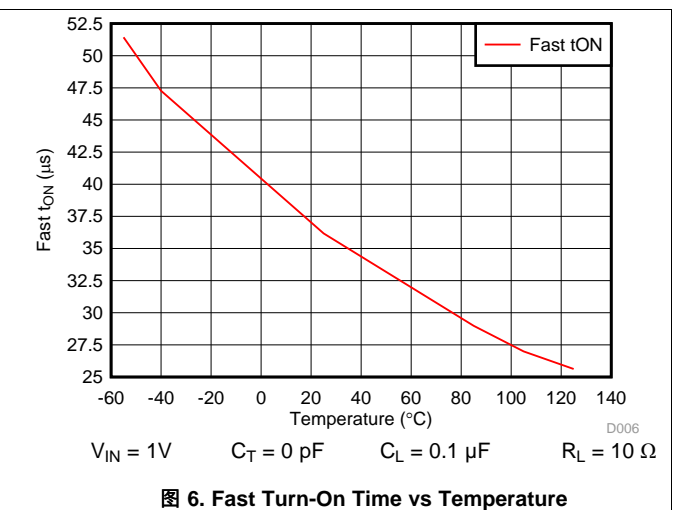

图 8. PG Turn-On Time vs Temperature

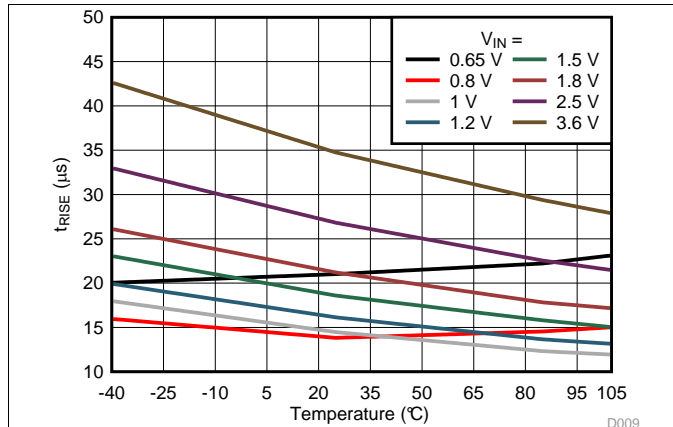

图 9. PG Turn-Off Time vs Temperature

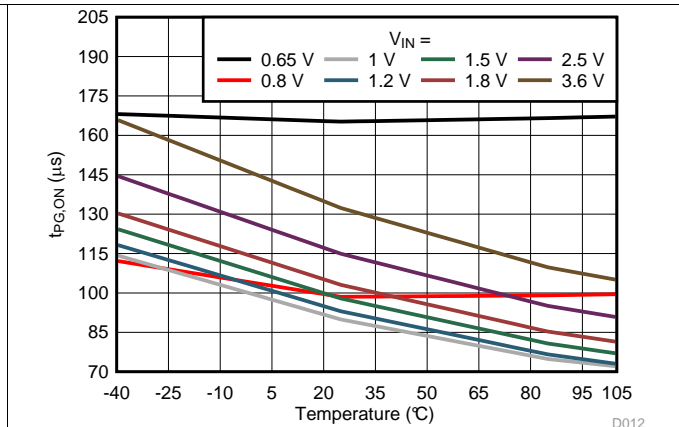

图 10. Turn-Off Time vs Temperature

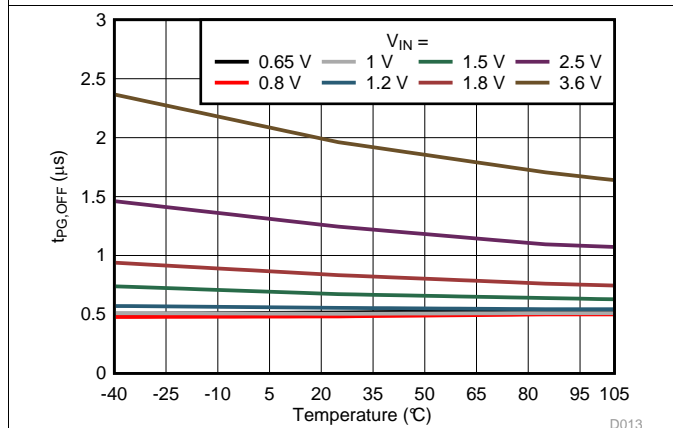

$R_L = 10 \Omega$   $C_L = 0.1 \mu F$

图 11. Fall Time vs Temperature

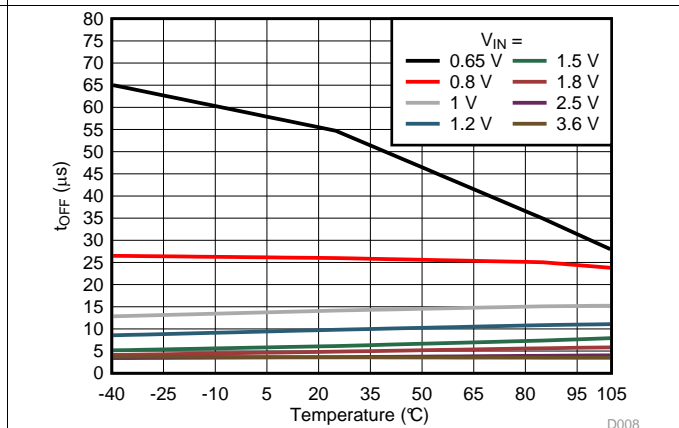
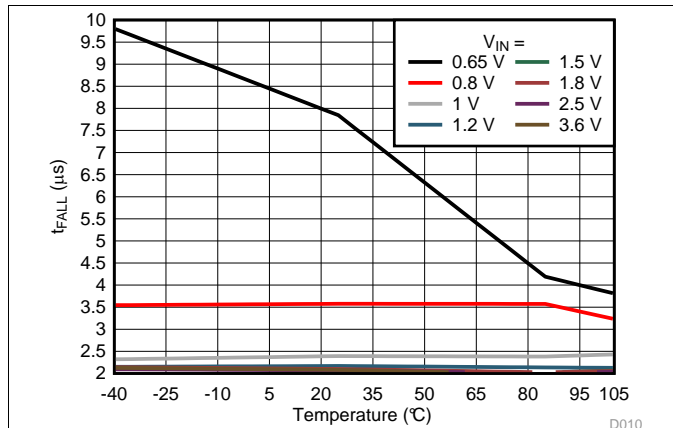
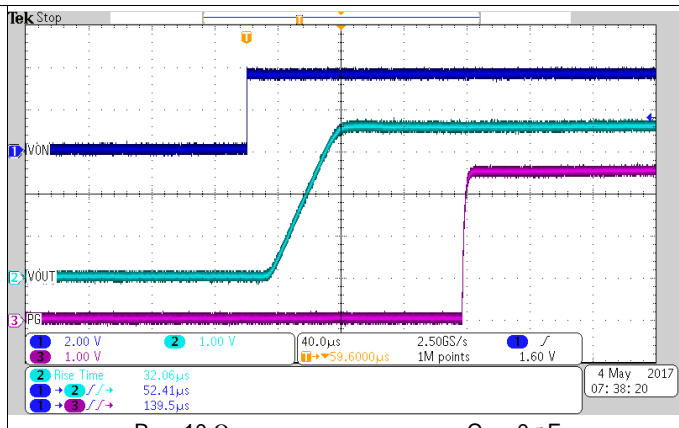

$R_L = 10 \Omega$   $C_T = 0 \text{ pF}$   
 $T_A = 25^\circ\text{C}$   $C_L = 0.1 \mu F$

图 12. Turn-On Response at 3.6 VIN

Typical AC Characteristics (接下页)

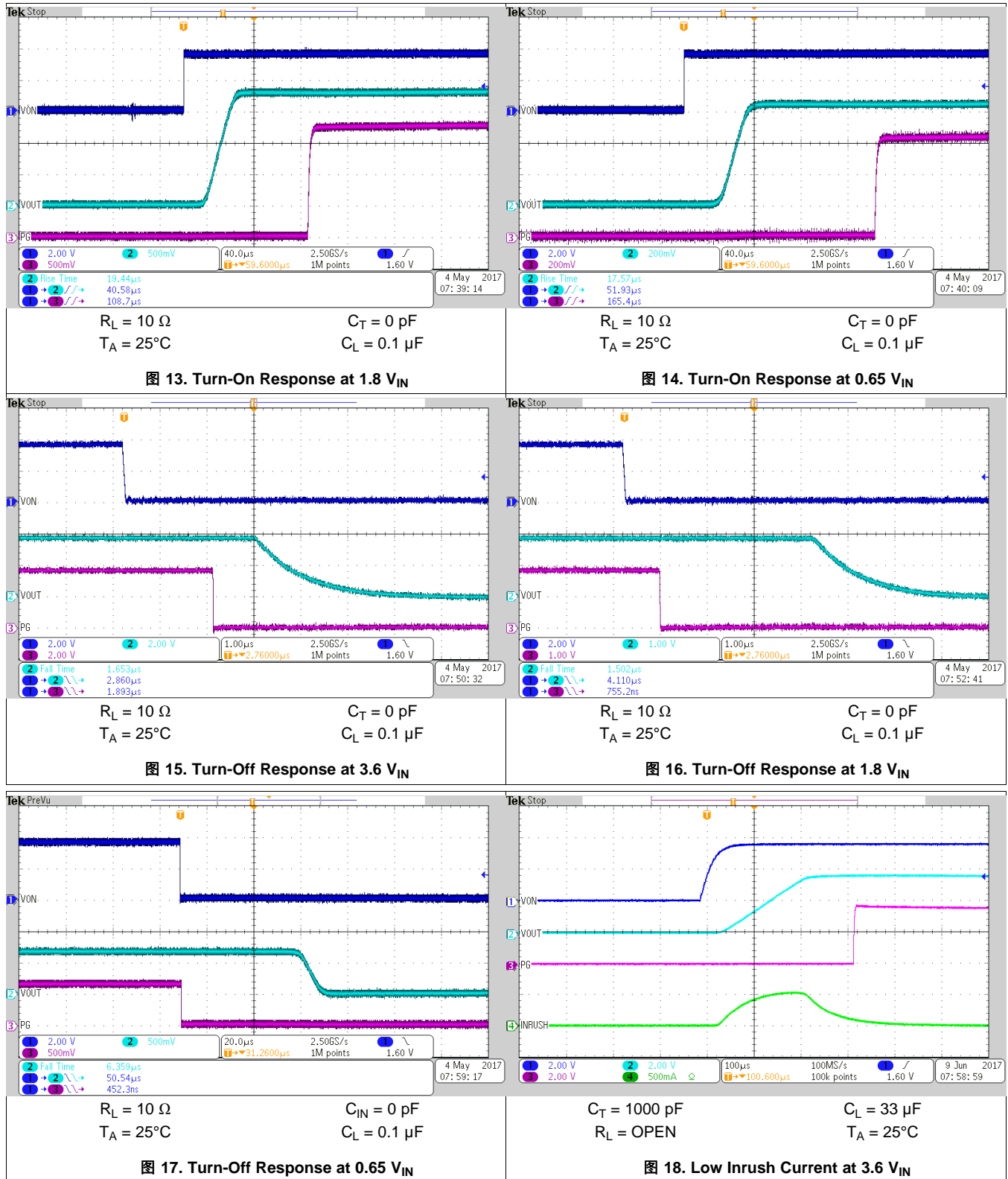

Typical AC Characteristics (接下页)

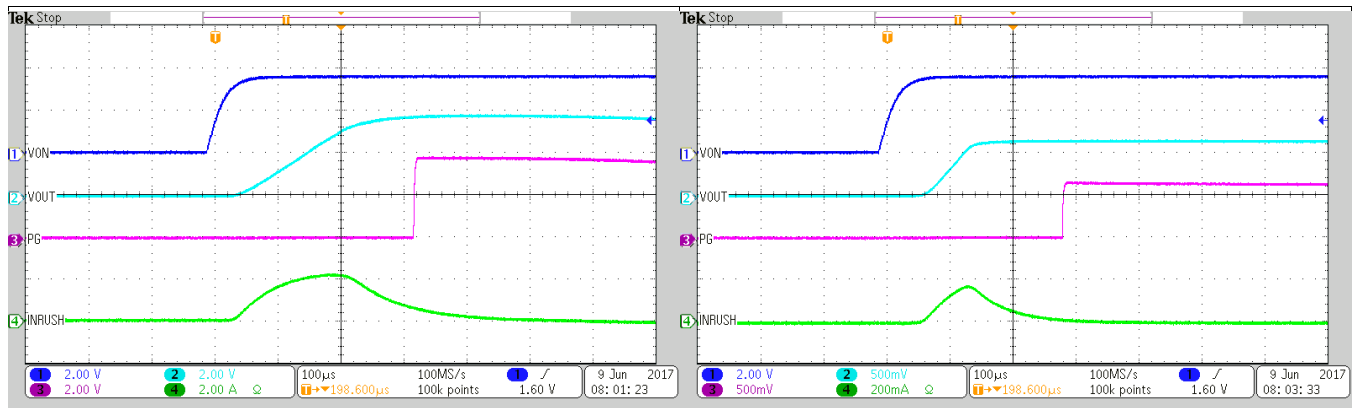

$C_T = 1000 \text{ pF}$   
 $R_L = \text{OPEN}$   
 $C_L = 133 \text{ }\mu\text{F}$   
 $T_A = 25^\circ\text{C}$

图 19. High Inrush Current at 3.6 V<sub>IN</sub>

$C_T = 1000 \text{ pF}$   
 $R_L = \text{OPEN}$   
 $C_L = 33 \text{ }\mu\text{F}$   
 $T_A = 25^\circ\text{C}$

图 20. Low Inrush Current at 0.65 V<sub>IN</sub>

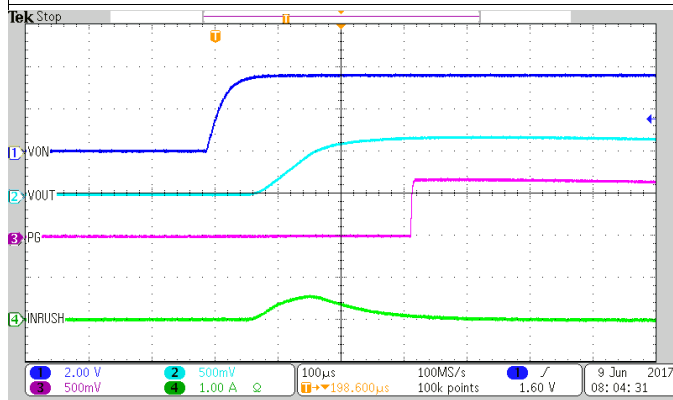

$C_T = 1000 \text{ pF}$   
 $R_L = \text{OPEN}$   
 $C_L = 133 \text{ }\mu\text{F}$   
 $T_A = 25^\circ\text{C}$

图 21. High Inrush Current at 0.65 V<sub>IN</sub>

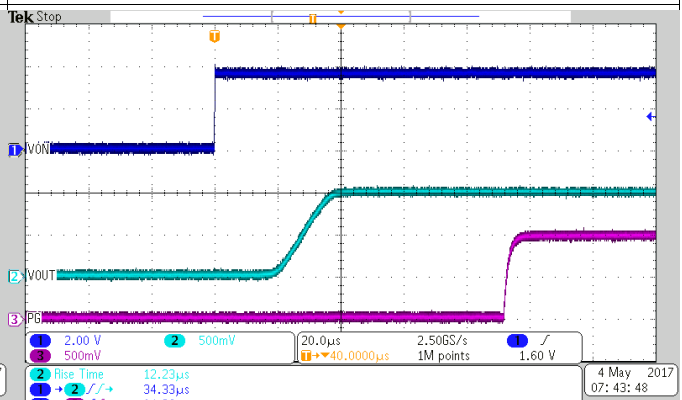

$C_T = 0 \text{ pF}$   
 $R_L = 10 \text{ }\Omega$   
 $C_L = 0.1 \text{ }\mu\text{F}$   
 $T_A = 25^\circ\text{C}$

图 22. Fast Turn-On Response

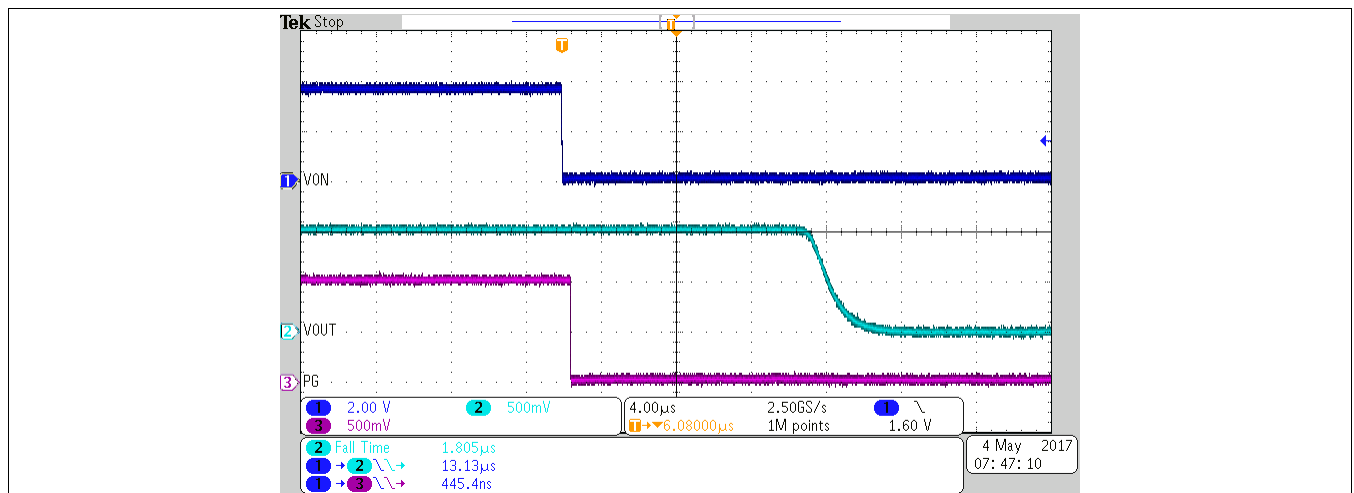

$C_{IN} = 0 \text{ pF}$   
 $R_L = 10 \text{ }\Omega$

$C_L = 0.1 \text{ }\mu\text{F}$   
 $T_A = 25^\circ\text{C}$

图 23. Fast Turn-Off Response

## 7 Parameter Measurement Information

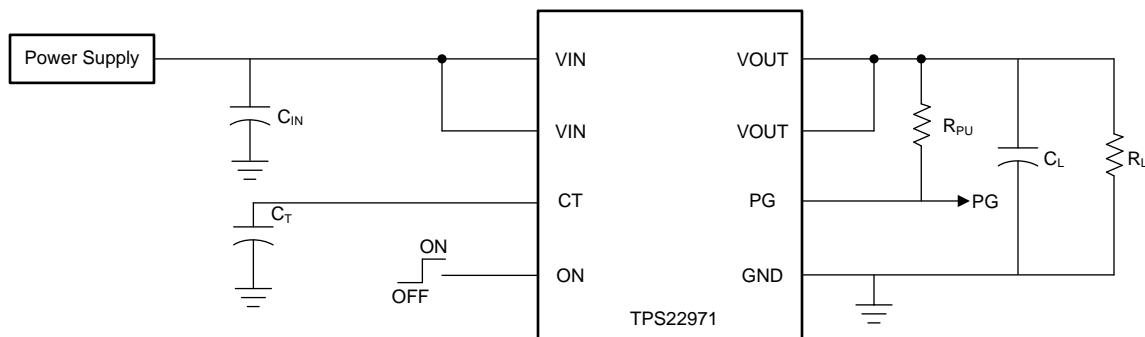

Copyright © 2017, Texas Instruments Incorporated

图 24. TPS22971 Test Circuit



图 25. AC Timing Waveforms

## 8 Detailed Description

### 8.1 Overview

The TPS22971 is a single channel, 3-A load switch in a small, space-saving WCSP-8 package. This device implements a low resistance N-channel MOSFET with a controlled rise time for applications that need to limit the inrush current.

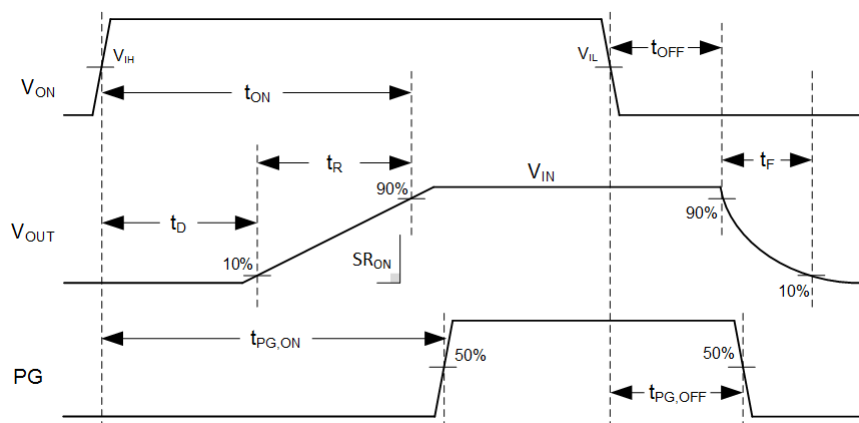
The controlled rise time for the device greatly reduces inrush current caused by large bulk load capacitances, thereby reducing or eliminating power supply droop. The adjustable slew rate through CT provides the design flexibility to trade off the inrush current and power up timing requirements. Integrated PG indicator notifies the system about the status of the load switch to facilitate seamless power sequencing.

This device is also designed to have very low leakage current during off state, which prevents downstream circuits from pulling high standby current from the supply. Integrated control logic, driver, power supply, and output discharge FET eliminates the need for additional external components, which reduces solution size and bill of materials (BOM) count.

### 8.2 Functional Block Diagram

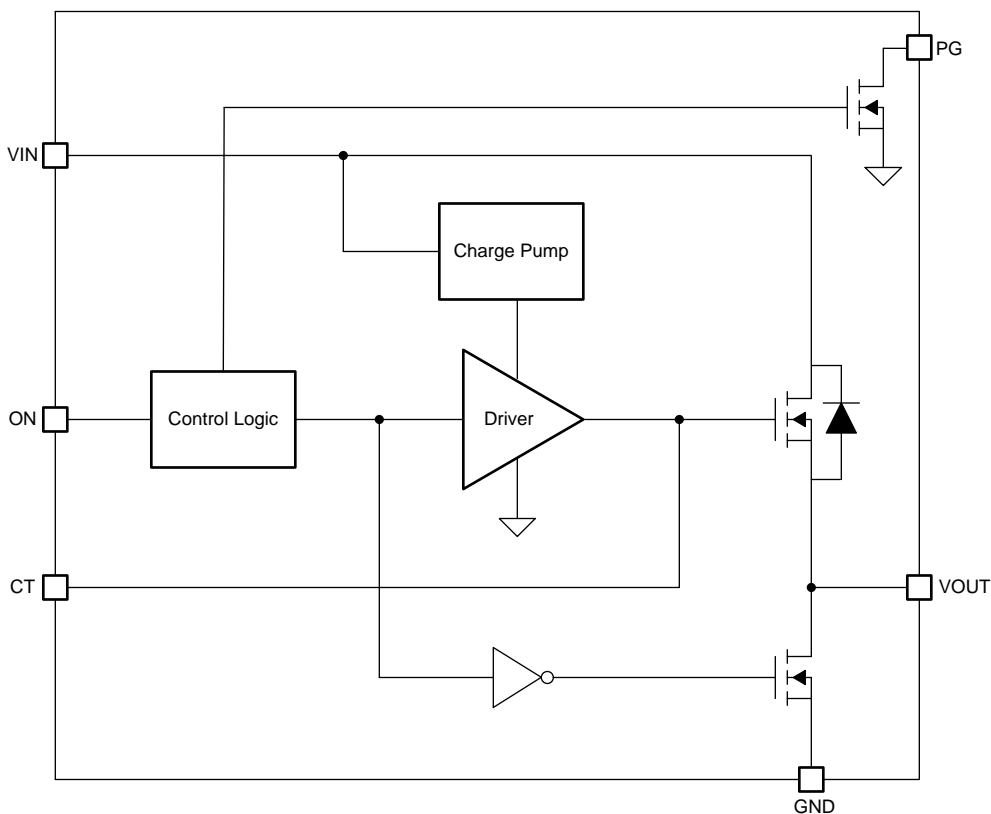

Copyright © 2017, Texas Instruments Incorporated

### 8.3 Feature Description

#### 8.3.1 On and Off Control

The ON pin controls the state of the switch. Asserting ON high enables the switch. ON has a low threshold, making it capable of interfacing with low-voltage signals. The ON pin is compatible with standard GPIO logic. It can be used with any microcontroller with 1.2-V, 1.8-V, 2.5-V or 3.3-V GPIOs. This pin does not have an internal bias and must not be left floating for proper functionality.

## Feature Description (接下页)

### 8.3.2 Controlled Turn-On

The TPS22971 has controlled Turn-On for inrush current control. A capacitor to GND on the CT pin adjusts the slew rate. For a given input voltage and desired slew rate, [公式 1](#) can be used to find the required CT value. For calculated CT values less than 220 pF, use 0 pF instead when solving for  $t_{ON}$  and  $t_{PG,ON}$ .

$$CT(VIN, SR) = \frac{\left(\frac{VIN}{SR} - (3.1 \times VIN) - 14.2\right) \times 800}{((32.5 \times VIN) + 12.5)}$$

where

- CT is the capacitor on the CT pin (in pF)
  - VIN is the input voltage (in V)
  - SR is the desired slew rate (in V/μs)
- (1)

The CT value determined in [公式 1](#) can be used to find the total Turn-On time,  $t_{ON}$ , in [公式 2](#) or [公式 3](#) depending on  $V_{IN}$ .

$$t_{ON}(VIN \geq 0.95 V, CT) = \left( (15 + (33 \times VIN)) \times \frac{CT}{1000} \right) + ((3.9 \times VIN) + 35)$$
(2)

$$t_{ON}(VIN < 0.95 V, CT) = \left( (45 + (33 \times VIN)) \times \frac{CT}{1000} \right) + ((3.9 \times VIN) + 55)$$

where

- $t_{ON}$  is the Turn-On time (in μs)
  - CT is the capacitor on the CT pin (in pF)
  - VIN is the input voltage (in V)
- (3)

### 8.3.3 Power Good (PG)

The TPS22971 has a power good (PG) output signal to indicate the gate of the pass FET is driven high and the switch is fully on (full load ready). The signal is an active high and open drain output which can be connected to a voltage source through an external pull up resistor,  $R_{PU}$ . This voltage source can be  $V_{OUT}$  from the TPS22971 or another external voltage. [公式 4](#) and [公式 5](#) show the approximate equation for the relationship between CT setting,  $V_{IN}$  and PG Turn-On time ( $t_{PG,ON}$ ):

$$t_{PG,ON}(VIN \geq 0.95 V, CT) = \left( (40 + (36 \times VIN)) \times \frac{CT}{1000} \right) + ((10.7 \times VIN) + 85)$$
(4)

$$t_{PG,ON}(VIN < 0.95 V, CT) = \left( (80 + (36 \times VIN)) \times \frac{CT}{1000} \right) + ((10.7 \times VIN) + 155)$$

where

- $t_{PG,ON}$  is the PG Turn-On time (in μs)
  - $V_{IN}$  is the input voltage (in V)
  - $C_T$  is the capacitance value on the CT pin (in pF)
- (5)

### 8.3.4 Quick Output Discharge (QOD)

The TPS22971 includes a QOD feature. When the switch is disabled, a discharge resistor is connected between  $V_{OUT}$  and GND. This resistor has a typical value of 150 Ω and prevents the output from floating while the switch is disabled. The QOD pull-down resistance can vary with input voltage and temperature, see [图 4](#).

## 8.4 Device Functional Modes

表 1 lists the functional modes for the TPS22971.

表 1. Function Table

TPS22971			
ON-Pin	$V_{IN}$ to $V_{OUT}$	$V_{OUT}$ to GND	PG to GND
Below $V_{IL}$	OFF	ON	ON
Above $V_{IH}$	ON	OFF	OFF

## 9 Application and Implementation

### 注

Information in the following applications sections is not part of the TI component specification, and TI does not warrant its accuracy or completeness. TI's customers are responsible for determining suitability of components for their purposes. Customers should validate and test their design implementation to confirm system functionality.

### 9.1 Application Information

#### 9.1.1 Thermal Consideration

It is recommended to limit the junction temperature ( $T_J$ ) to below 125°C. To calculate the maximum allowable dissipation,  $P_{D(max)}$  for a given output current and ambient temperature, use [公式 6](#) as a guideline:

$$P_{D(max)} = \frac{T_{J(max)} - T_A}{\theta_{JA}}$$

where

- $P_{D(max)}$  is maximum allowable power dissipation
- $T_{J(max)}$  is maximum allowable junction temperature
- $T_A$  is ambient temperature of the device
- $\theta_{JA}$  is junction to air thermal impedance. See the [Thermal Information](#) section. This parameter is highly dependent upon board layout

(6)

#### 9.1.2 PG Pull Up Resistor

The PG output is an open drain signal which connects to a voltage source through a pull up resistor  $R_{PU}$ . The PG signal can be used to drive the enable pins of downstream devices, EN. PG is active high, and its voltage is given by [公式 7](#).

$$V_{PG} = V_{OUT} - (I_{PG,LK} + I_{EN,LK}) \times R_{PU}$$

where

- $V_{OUT}$  is the voltage where PG is tied to
- $I_{PG,LK}$  is the leakage current into PG pin
- $I_{EN,LK}$  is the leakage current into the EN pin driven by PG
- $R_{PU}$  is the pull up resistance

(7)

$V_{PG}$  needs to be higher than  $V_{IH,MIN}$  of the EN pin to be treated as logic high. The maximum  $R_{PU}$  is determined by [公式 8](#).

$$R_{PU,MAX} = \frac{V_{OUT} - V_{IH,MIN}}{I_{PG,LK} + I_{EN,LK}}$$

(8)

When PG is disabled, with 1 mA current into PG pin ( $I_{PG} = 1$  mA),  $V_{PG,OL}$  is less than 0.2 V and treated as logic low as long as  $V_{IL,MAX}$  of the EN pin is greater than 0.2 V. The minimum  $R_{PU}$  is determined by [公式 9](#).

$$R_{PU,MIN} = \frac{V_{OUT}}{I_{PG} + I_{EN,LK}}$$

(9)

$R_{PU}$  can be chosen within the range defined by  $R_{PU,MIN}$  and  $R_{PU,MAX}$ .  $R_{PU} = 10$  k $\Omega$  is used for characterization.

#### 9.1.3 Power Sequencing

The TPS22971 has an integrated power good indicator which can be used for power sequencing. As shown in [图 26](#), the switch to the second load is controlled by the PG signal from the first switch. This ensures that the power to load 2 is only enabled after the same power to load 1 is enabled after the first switch has turned on.

Application Information (接下页)

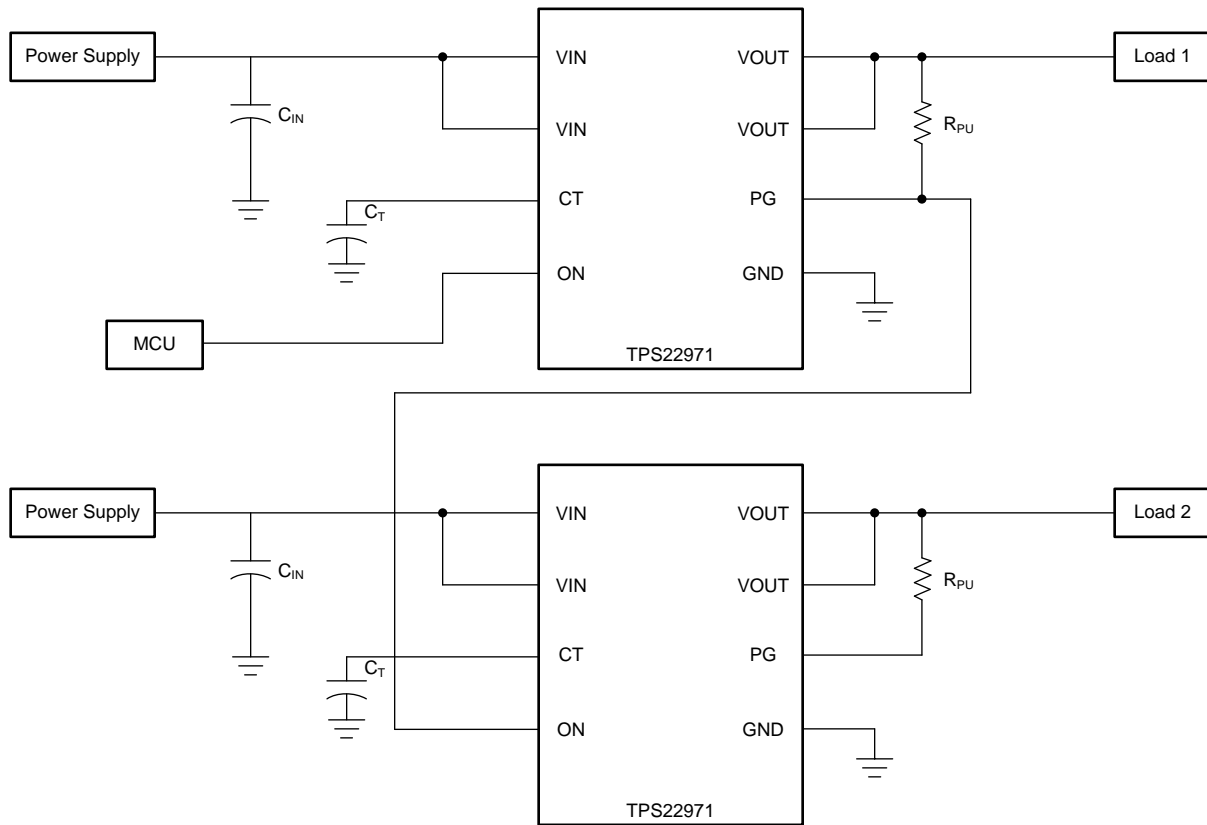

Copyright © 2017, Texas Instruments Incorporated

图 26. Power Sequencing

## 9.2 Typical Application

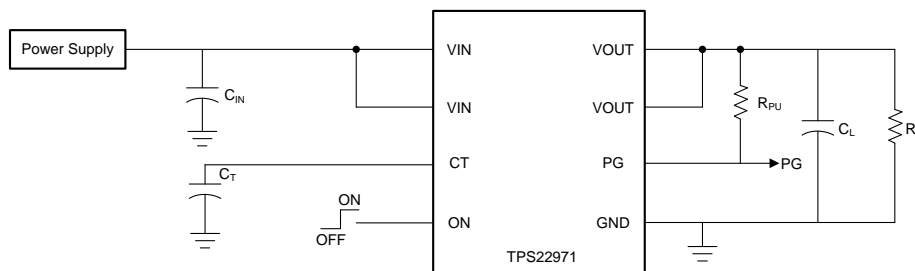

Copyright © 2017, Texas Instruments Incorporated

图 27. Typical Application Circuit

### 9.2.1 Design Requirements

For this design example, below, use the input parameters shown in 表 2.

表 2. Design Parameters

DESIGN PARAMETER	EXAMPLE VALUE
$V_{IN}$	3.6 V
$I_{LOAD}$	10 mA
Load Capacitance ( $C_L$ )	33 $\mu$ F
Maximum Voltage Drop	1%
Maximum Inrush Current	630 mA

### 9.2.2 Detailed Design Procedure

#### 9.2.2.1 Maximum Voltage Drop and On-Resistance

At 3.6-V input voltage, with a maximum voltage drop tolerance of 1%, the TPS22971 has a typical  $R_{ON}$  of 6.7 m $\Omega$ . The rail is supplying 10 mA of current; the voltage drop for a rail is calculated based on 公式 10.

$$V_{DROD} = R_{ON} \times I_{LOAD} \quad (10)$$

$$V_{DROD} = 0.067 \text{ mV} \quad (11)$$

The maximum voltage drop is 1% which is 36 mV. The voltage drop caused by the load current across the on resistance is 0.067 mV.

#### 9.2.2.2 Managing Inrush Current

When the switch is enabled, the output capacitors must be charged up from 0 V to  $V_{IN}$ . This charge arrives in the form of inrush current. Given a load capacitance ( $C_L$ ) of 33  $\mu$ F, an input voltage ( $V_{IN}$ ) of 3.6V and a maximum inrush ( $I_{INRUSH}$ ) of 630 mA, use 公式 12 and 公式 13 to solve for Slew Rate (SR).

$$SR = \frac{I_{INRUSH}}{C_L} \quad (12)$$

$$SR = 0.0191 \text{ V} / \mu\text{s} \quad (13)$$

Now that the desired slew rate has been calculated, use SR and  $V_{IN}$  in 公式 14 to calculate a CT capacitance value.

$$CT(V_{IN}, SR) = 1007 \text{ pF} \quad (14)$$

A capacitance value of 1007pF is a non-standard value therefore a 1000 pF CT capacitance is used moving forward.

The calculated CT value can be used with 公式 2 and 公式 4 to determine  $t_{ON}$  and  $t_{PG,ON}$ , respectively as shown in 公式 15 and 公式 16.

TPS22971

ZHCSGK9B – APRIL 2017 – REVISED DECEMBER 2017

www.ti.com.cn

$$t_{ON} (V_{IN}, C_T) = 182.8 \mu s \tag{15}$$

$$t_{PG, ON} (V_{IN}, C_T) = 293.1 \mu s \tag{16}$$

9.2.3 Application Curves



图 28. TPS22971 Inrush Current With  $C_T = 0$  pF



图 29. TPS22971 Inrush Current With  $C_T = 1000$  pF

## 10 Power Supply Recommendations

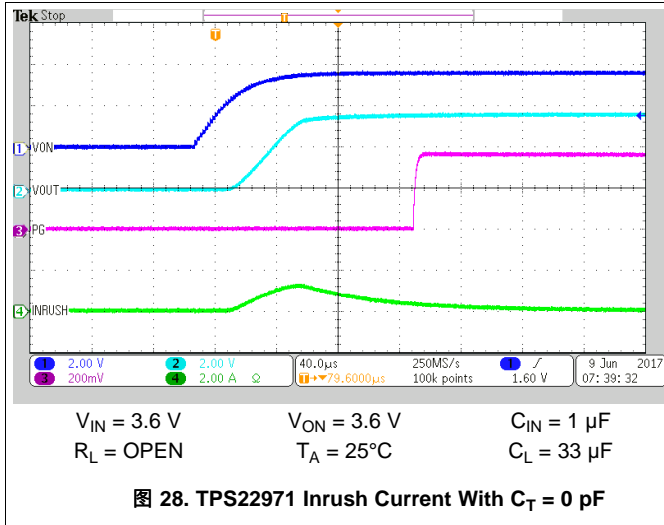
The device is designed to operate from a  $V_{IN}$  range of 0.65 V to 3.6 V. The  $V_{IN}$  power supply must be well regulated and placed as close to the device terminal as possible. The power supply must be able to withstand all transient load current steps. In most situations, using an input capacitance of 1  $\mu\text{F}$  is sufficient to prevent the supply voltage from dipping when the switch is turned on. In cases where the power supply is slow to respond to a large transient current or large load current step, additional bulk capacitance may be required on the input.

The requirements for larger input capacitance can be mitigated by adding additional capacitance to the CT pin. This causes the load switch to turn on more slowly. Not only does this reduce transient inrush current, but it also gives the power supply more time to respond to the load current step.

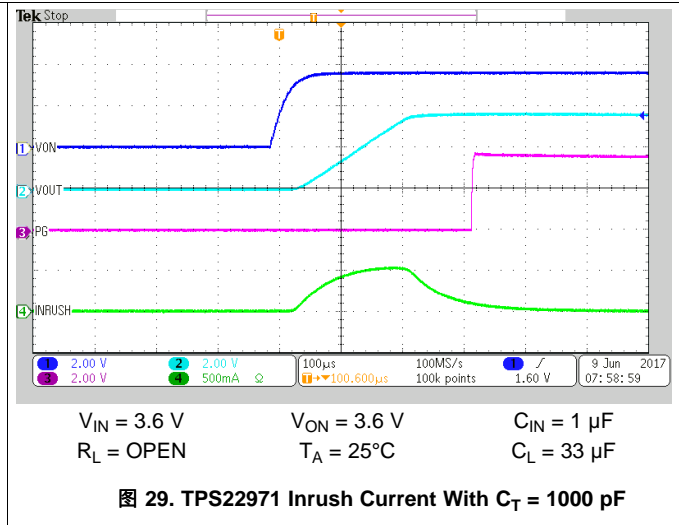
## 11 Layout

### 11.1 Layout Guidelines

All traces must be as short as possible for best performance. Using wide traces for  $V_{IN}$ ,  $V_{OUT}$ , and GND helps minimize the parasitic electrical effects along with minimizing the thermal impedance. The CT trace must be as short as possible to reduce parasitic capacitance.

### 11.2 Layout Example



图 30. Package Layout Examples

## 12 器件和文档支持

### 12.1 文档支持

#### 12.1.1 相关文档

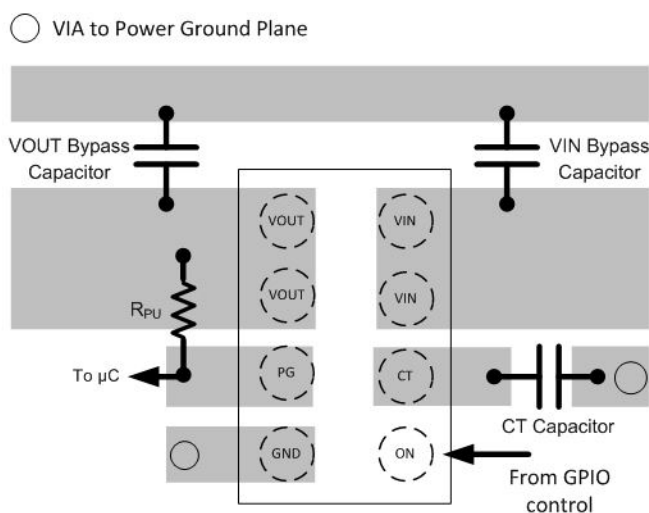
请参阅如下相关文档：

[《TPS22971 负载开关评估模块用户指南》](#)

### 12.2 接收文档更新通知

如需接收文档更新通知，请访问 [ti.com](http://ti.com) 上的器件产品文件夹。单击右上角的 [通知我](#) 进行注册，即可每周接收产品信息更改摘要。有关更改的详细信息，请查看任何已修订文档中包含的修订历史记录。

### 12.3 社区资源

下列链接提供到 TI 社区资源的连接。链接的内容由各个分销商“按照原样”提供。这些内容并不构成 TI 技术规范，并且不一定反映 TI 的观点；请参阅 TI 的 [《使用条款》](#)。

**TI E2E™ 在线社区** [TI 的工程师对工程师 \(E2E\) 社区](#)。此社区的创建目的在于促进工程师之间的协作。在 [e2e.ti.com](http://e2e.ti.com) 中，您可以咨询问题、分享知识、拓展思路并与同行工程师一道帮助解决问题。

**设计支持** [TI 参考设计支持](#) 可帮助您快速查找有帮助的 E2E 论坛、设计支持工具以及技术支持的联系信息。

### 12.4 商标

E2E is a trademark of Texas Instruments.  
All other trademarks are the property of their respective owners.

### 12.5 静电放电警告



ESD 可能会损坏该集成电路。德州仪器 (TI) 建议通过适当的预防措施处理所有集成电路。如果不遵守正确的处理措施和安装程序，可能会损坏集成电路。

ESD 的损坏小至导致微小的性能降级，大至整个器件故障。精密的集成电路可能更容易受到损坏，这是因为非常细微的参数更改都可能会导致器件与其发布的规格不相符。

### 12.6 Glossary

[SLYZ022](#) — *TI Glossary*.

This glossary lists and explains terms, acronyms, and definitions.

## 13 机械、封装和可订购信息

以下页面包含机械、封装和可订购信息。这些信息是指定器件的最新可用数据。数据如有变更，恕不另行通知和修订此文档。如欲获取此产品说明书的浏览器版本，请参阅左侧的导航。

**PACKAGING INFORMATION**

Orderable part number	Status (1)	Material type (2)	Package   Pins	Package qty   Carrier	RoHS (3)	Lead finish/ Ball material (4)	MSL rating/ Peak reflow (5)	Op temp (°C)	Part marking (6)
<a href="#">TPS22971YZPR</a>	Active	Production	DSBGA (YZP)   8	3000   LARGE T&R	Yes	SNAGCU	Level-1-260C-UNLIM	-40 to 85	1CKI
TPS22971YZPR.A	Active	Production	DSBGA (YZP)   8	3000   LARGE T&R	Yes	SNAGCU	Level-1-260C-UNLIM	-40 to 105	1CKI
<a href="#">TPS22971YZPT</a>	Active	Production	DSBGA (YZP)   8	250   SMALL T&R	Yes	SNAGCU	Level-1-260C-UNLIM	-40 to 85	1CKI
TPS22971YZPT.A	Active	Production	DSBGA (YZP)   8	250   SMALL T&R	Yes	SNAGCU	Level-1-260C-UNLIM	-40 to 105	1CKI

(1) **Status:** For more details on status, see our [product life cycle](#).

(2) **Material type:** When designated, preproduction parts are prototypes/experimental devices, and are not yet approved or released for full production. Testing and final process, including without limitation quality assurance, reliability performance testing, and/or process qualification, may not yet be complete, and this item is subject to further changes or possible discontinuation. If available for ordering, purchases will be subject to an additional waiver at checkout, and are intended for early internal evaluation purposes only. These items are sold without warranties of any kind.

(3) **RoHS values:** Yes, No, RoHS Exempt. See the [TI RoHS Statement](#) for additional information and value definition.

(4) **Lead finish/Ball material:** Parts may have multiple material finish options. Finish options are separated by a vertical ruled line. Lead finish/Ball material values may wrap to two lines if the finish value exceeds the maximum column width.

(5) **MSL rating/Peak reflow:** The moisture sensitivity level ratings and peak solder (reflow) temperatures. In the event that a part has multiple moisture sensitivity ratings, only the lowest level per JEDEC standards is shown. Refer to the shipping label for the actual reflow temperature that will be used to mount the part to the printed circuit board.

(6) **Part marking:** There may be an additional marking, which relates to the logo, the lot trace code information, or the environmental category of the part.

Multiple part markings will be inside parentheses. Only one part marking contained in parentheses and separated by a "~" will appear on a part. If a line is indented then it is a continuation of the previous line and the two combined represent the entire part marking for that device.

**Important Information and Disclaimer:** The information provided on this page represents TI's knowledge and belief as of the date that it is provided. TI bases its knowledge and belief on information provided by third parties, and makes no representation or warranty as to the accuracy of such information. Efforts are underway to better integrate information from third parties. TI has taken and continues to take reasonable steps to provide representative and accurate information but may not have conducted destructive testing or chemical analysis on incoming materials and chemicals. TI and TI suppliers consider certain information to be proprietary, and thus CAS numbers and other limited information may not be available for release.

In no event shall TI's liability arising out of such information exceed the total purchase price of the TI part(s) at issue in this document sold by TI to Customer on an annual basis.

**TAPE AND REEL INFORMATION**

**QUADRANT ASSIGNMENTS FOR PIN 1 ORIENTATION IN TAPE**

\*All dimensions are nominal

Device	Package Type	Package Drawing	Pins	SPQ	Reel Diameter (mm)	Reel Width W1 (mm)	A0 (mm)	B0 (mm)	K0 (mm)	P1 (mm)	W (mm)	Pin1 Quadrant
TPS22971YZPR	DSBGA	YZP	8	3000	180.0	8.4	1.02	2.02	0.63	2.0	8.0	Q1
TPS22971YZPR	DSBGA	YZP	8	3000	180.0	8.4	1.0	2.06	0.63	2.0	8.0	Q1
TPS22971YZPT	DSBGA	YZP	8	250	180.0	8.4	1.0	2.06	0.63	2.0	8.0	Q1
TPS22971YZPT	DSBGA	YZP	8	250	180.0	8.4	1.02	2.02	0.63	2.0	8.0	Q1

## TAPE AND REEL BOX DIMENSIONS



\*All dimensions are nominal

Device	Package Type	Package Drawing	Pins	SPQ	Length (mm)	Width (mm)	Height (mm)
TPS22971YZPR	DSBGA	YZP	8	3000	182.0	182.0	20.0
TPS22971YZPR	DSBGA	YZP	8	3000	182.0	182.0	20.0
TPS22971YZPT	DSBGA	YZP	8	250	182.0	182.0	20.0
TPS22971YZPT	DSBGA	YZP	8	250	182.0	182.0	20.0

YZP0008

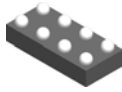

PACKAGE OUTLINE

DSBGA - 0.5 mm max height

DIE SIZE BALL GRID ARRAY

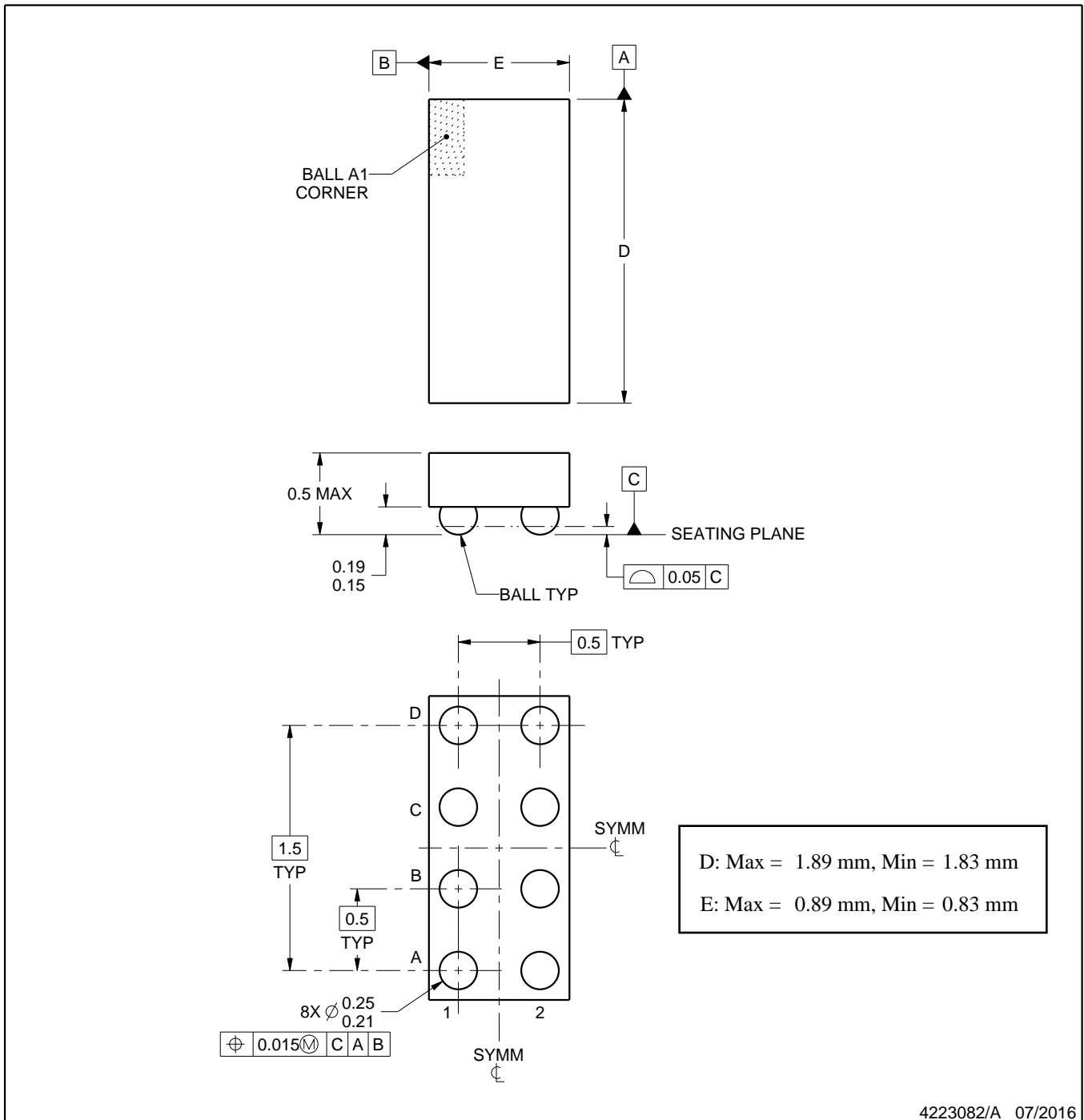

NOTES:

1. All linear dimensions are in millimeters. Any dimensions in parenthesis are for reference only. Dimensioning and tolerancing per ASME Y14.5M.
2. This drawing is subject to change without notice.

# EXAMPLE BOARD LAYOUT

YZP0008

DSBGA - 0.5 mm max height

DIE SIZE BALL GRID ARRAY



LAND PATTERN EXAMPLE  
SCALE:40X



SOLDER MASK DETAILS  
NOT TO SCALE

4223082/A 07/2016

NOTES: (continued)

- Final dimensions may vary due to manufacturing tolerance considerations and also routing constraints. For more information, see Texas Instruments literature number SNVA009 ([www.ti.com/lit/snva009](http://www.ti.com/lit/snva009)).

# EXAMPLE STENCIL DESIGN

YZP0008

DSBGA - 0.5 mm max height

DIE SIZE BALL GRID ARRAY



SOLDER PASTE EXAMPLE  
BASED ON 0.1 mm THICK STENCIL  
SCALE:40X

4223082/A 07/2016

NOTES: (continued)

4. Laser cutting apertures with trapezoidal walls and rounded corners may offer better paste release.

## 重要通知和免责声明

TI“按原样”提供技术和可靠性数据（包括数据表）、设计资源（包括参考设计）、应用或其他设计建议、网络工具、安全信息和其他资源，不保证没有瑕疵且不做任何明示或暗示的担保，包括但不限于对适销性、与某特定用途的适用性或不侵犯任何第三方知识产权的暗示担保。

这些资源可供使用 TI 产品进行设计的熟练开发人员使用。您将自行承担以下全部责任：(1) 针对您的应用选择合适的 TI 产品，(2) 设计、验证并测试您的应用，(3) 确保您的应用满足相应标准以及任何其他安全、安保法规或其他要求。

这些资源如有变更，恕不另行通知。TI 授权您仅可将这些资源用于研发本资源所述的 TI 产品的相关应用。严禁以其他方式对这些资源进行复制或展示。您无权使用任何其他 TI 知识产权或任何第三方知识产权。对于因您对这些资源的使用而对 TI 及其代表造成的任何索赔、损害、成本、损失和债务，您将全额赔偿，TI 对此概不负责。

TI 提供的产品受 [TI 销售条款](#)、[TI 通用质量指南](#) 或 [ti.com](#) 上其他适用条款或 TI 产品随附的其他适用条款的约束。TI 提供这些资源并不会扩展或以其他方式更改 TI 针对 TI 产品发布的适用的担保或担保免责声明。除非德州仪器 (TI) 明确将某产品指定为定制产品或客户特定产品，否则其产品均为按确定价格收入目录的标准通用器件。

TI 反对并拒绝您可能提出的任何其他或不同的条款。

版权所有 © 2026，德州仪器 (TI) 公司

最后更新日期：2025 年 10 月