

具有可编程复位延迟功能的 TPS3430 窗口看门狗计时器

1 特性

- 出厂编程的精密看门狗计时器：
 - 可在 25°C 下实现 $\pm 2.5\%$ 的看门狗超时和看门狗复位延迟精度 (典型值)
- 看门狗禁用功能
- 用户可编程看门狗超时
- 用户可编程看门狗复位延迟
- 输入电压范围：VDD = 1.6V 至 6.5V
- 低电源电流： $I_{DD} = 10\mu A$ (典型值)
- 开漏输出
- 小型 3mm × 3mm 10 引脚 VSON 封装
- 工作结温范围：
 - 40°C 至 +125°C

2 应用

- 智能显示屏
- 电池组：电动自行车/电动踏板车/轻型电动车辆 (LEV)
- 断路器 (ACB、MCCB、VCB)
- 电动自行车/脚踏电动自行车
- 交流充电 (桩) 站
- 多功能继电器
- 视觉计算机

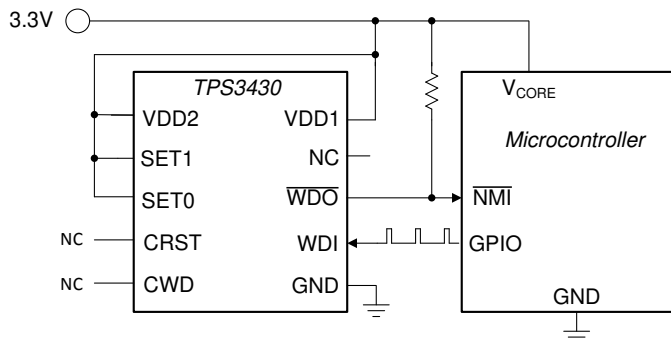

窗口监视器计时器电路

3 说明

TPS3430 是一款具有可编程看门狗窗口和可编程看门狗复位延迟的独立窗口看门狗计时器，适用于各种应用。TPS3430 窗口看门狗可实现 2.5% 的计时精度 (25°C 时的典型值)，而且可通过出厂编程的默认延迟设置来设置看门狗输出 (WDO) 复位延迟，或通过外部电容器进行编程。在开发过程中或上电期间，可以通过 SET 引脚将监视器禁用，从而避免出现不必要的监视器超时。

TPS3430 采用小型 3.00mm × 3.00mm 10 引脚 VSON 封装。

器件信息

器件型号	封装 (1)	封装尺寸 (标称值)
TPS3430	VSON (10)	3.00mm × 3.00mm

(1) 如需了解所有可用封装，请参阅产品说明书末尾的可订购产品附录。

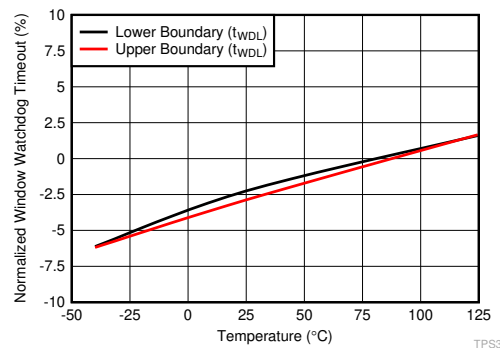

工作温度范围内的标准化监视器超时精度 (SET0 = 1, SET1 = 1, CWD = NC)



Table of Contents

1 特性	1	7.4 Device Functional Modes.....	15
2 应用	1	8 Application and Implementation	16
3 说明	1	8.1 Application Information.....	16
4 Revision History	2	8.2 Typical Applications.....	19
5 Pin Configuration and Functions	3	9 Power Supply Recommendations	26
6 Specifications	4	10 Layout	27
6.1 Absolute Maximum Ratings.....	4	10.1 Layout Guidelines.....	27
6.2 ESD Ratings.....	4	10.2 Layout Example.....	27
6.3 Recommended Operating Conditions.....	4	11 Device and Documentation Support	28
6.4 Thermal Information.....	5	11.1 Device Support.....	28
6.5 Electrical Characteristics.....	5	11.2 Documentation Support.....	28
6.6 Timing Requirements.....	6	11.3 接收文档更新通知.....	28
6.7 Timing Diagrams.....	7	11.4 支持资源.....	28
6.8 Typical Characteristics.....	9	11.5 Trademarks.....	28
7 Detailed Description	10	11.6 Electrostatic Discharge Caution.....	28
7.1 Overview.....	10	11.7 术语表.....	28
7.2 Functional Block Diagrams.....	10	12 Mechanical, Packaging, and Orderable Information	28
7.3 Feature Description.....	10		

4 Revision History

注：以前版本的页码可能与当前版本的页码不同

Changes from Revision * (July 2018) to Revision A (October 2021)	Page
• 更新了整个文档中的表格、图和交叉参考的编号格式.....	1
• 删除了“可在工作温度范围内实现 $\pm 15\%$ 的监视器超时和监视器复位延迟精度”.....	1
• 删除了“15% 计时精度 (-40°C 至 $+125^{\circ}\text{C}$)”.....	1
• Updated ESD Ratings.....	4
• Updated I_{CWD} min and max spec.....	5
• Updated V_{CWD} min and max spec.....	5
• Added a footnote to for t_{INIT}	6
• Changed minimum and maximum specifications of 2nd, 5th, 6th, and 8th rows of t_{WDL} parameter.....	6
• Changed minimum and maximum specifications of 2nd and last rows of t_{WDU} parameter.....	6
• Updated \overline{WDO} delay time values for various capacitors in <i>Watchdog Reset Delay Time for Common Ideal Capacitor Values</i> table.....	16
• Changed minimum and maximum specifications for NC SETx 01 setting for both upper and lower watchdog boundaries, 10 k Ω to VDD SETx 00 and 01 settings for lower watchdog boundary, and 10 k Ω to VDD SETx 11 setting for both upper and lower watchdog boundaries in <i>Factory-Programmed Watchdog Timing</i> table...	18
• Updated t_{WDU} min and max values for all capacitors.....	18
• Updated t_{WDU} min and max boundry values from 0.85 and 1.15 to 0.905 and 1.095 respectively.....	18

5 Pin Configuration and Functions

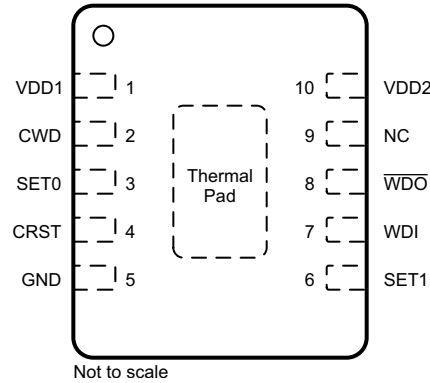

**图 5-1. DRC Package
3-mm × 3-mm VSON-10
Top View**

表 5-1. Pin Functions

PIN		I/O	DESCRIPTION
NAME	NO.		
VDD1	1	I	Supply voltage pin. For noisy systems, connecting a 0.1- μ F bypass capacitor is recommended.
CWD	2	I	Programmable watchdog timeout input. Watchdog timeout is set by connecting a capacitor between this pin and ground. Furthermore, this pin can also be connected by a 10-k Ω resistor to VDD, or leaving unconnected (NC) further enables the selection of the preset watchdog timeouts; see the # 6.6 table. When using a capacitor, the TPS3430 determines the window watchdog upper boundary with 方程式 4 . The lower watchdog boundary is set by the SET pins, see and 表 8-5 the # 8.1.2 section for additional information.
SET0	3	I	Logic input. SET0, SET1, and CWD select the watchdog window ratios, timeouts, and disable the watchdog; see the # 6.6 table.
CRST	4	I	Programmable watchdog reset delay pin. Connect a capacitor between this pin and GND to program the watchdog reset delay period. This pin can also be connected by a 10-k Ω pull-up resistor to VDD, or left unconnected (NC) for various factory programmed watchdog reset delay options; see the # 8.1.1 section. When using an external capacitor, use 方程式 1 to determine the watchdog reset delay.
GND	5	—	Ground pin
SET1	6	I	Logic input. SET0, SET1, and CWD select the watchdog window ratios, timeouts, and disable the watchdog; see the # 6.6 table.
WDI	7	I	Watchdog input. A falling transition (edge) must occur at this pin within the watchdog timeout between the lower ($t_{WDL(max)}$) and upper ($t_{WDU(min)}$) window boundaries in order for \overline{WDO} to not assert. During power up, all pulses to WDI are ignored before t_{RST} expires and the watchdog is disabled. When the watchdog is not in use, the SET pins can be used to disable the watchdog. The input at WDI is ignored when \overline{WDO} is low (asserted) and also when the watchdog is disabled. If the watchdog is disabled, then WDI cannot be left unconnected and must be driven to either VDD or GND.
\overline{WDO}	8	O	Watchdog open-drain active-low output. Connect \overline{WDO} with a 1-k Ω to 100-k Ω resistor to VDD or another power supply. \overline{WDO} goes low (asserts) when a watchdog timeout occurs. When a watchdog timeout occurs, \overline{WDO} goes low (asserts) for the set \overline{WDO} reset delay (t_{RST}). When the watchdog is disabled, \overline{WDO} remains logic high regardless of WDI.
NC	9	NC	This pin is no-connect and must be left floating.
VDD2	10	I	Connect this pin to VDD1. The device will not function properly if VDD1 and VDD2 are not externally connected.
Thermal pad		—	Connect the thermal pad to a large-area ground plane. The thermal pad is internally connected to GND.

6 Specifications

6.1 Absolute Maximum Ratings

over operating free-air temperature range (unless otherwise noted)⁽¹⁾

		MIN	MAX	UNIT
Supply voltage range	VDD1, VDD2	-0.3	7	V
Output voltage range	WDO	-0.3	7	V
Voltage ranges	SET0, SET1, WDI,	-0.3	7	V
	CWD, CRST	-0.3	VDD + 0.3 ⁽³⁾	
Output pin current	WDO		±20	mA
Input current (all pins)			±20	mA
Continuous total power dissipation		See § 6.4		
Temperature	Operating junction, T _J ⁽²⁾	-40	150	°C
	Operating free-air temperature, T _A ⁽²⁾	-40	150	
	Storage, T _{stg}	-65	150	

(1) Stresses beyond those listed under *Absolute Maximum Ratings* may cause permanent damage to the device. These are stress ratings only, which do not imply functional operation of the device at these or any other conditions beyond those indicated under *Recommended Operating Conditions*. Exposure to absolute-maximum-rated conditions for extended periods may affect device reliability.

(2) T_J = T_A as a result of the low dissipated power in this device.

(3) The absolute maximum rating is V_{DD} + 0.3 V or 7.0 V, whichever is smaller.

6.2 ESD Ratings

		VALUE	UNIT
V _(ESD) Electrostatic discharge	Human-body model (HBM), per ANSI/ESDA/JEDEC JS-001 ⁽¹⁾	±4000	V
	Charged-device model (CDM), per JEDEC specification JESD22-C101 ⁽²⁾	±1000	

(1) JEDEC document JEP155 states that 500-V HBM allows safe manufacturing with a standard ESD control process. Manufacturing with less than 500-V HBM is possible with the necessary precautions.

(2) JEDEC document JEP157 states that 250-V CDM allows safe manufacturing with a standard ESD control process. Manufacturing with less than 250-V CDM is possible with the necessary precautions.

6.3 Recommended Operating Conditions

over operating free-air temperature range (unless otherwise noted)

		MIN	NOM	MAX	UNIT
VDD1, VDD2	Supply pin voltage	1.6		6.5	V
V _{SET0}	SET0 pin voltage	0		6.5	V
V _{SET1}	SET1 pin voltage	0		6.5	V
C _{CRST}	WD reset delay capacitor	0.1 ⁽¹⁾		1000 ⁽¹⁾	nF
R _{CRST}	Pull-up resistor to VDD	9	10	11	kΩ
C _{CWD}	Watchdog timing capacitor	0.1 ⁽²⁾		1000 ⁽²⁾	nF
CWD	Pull-up resistor to VDD	9	10	11	kΩ
R _{PU}	Pull-up resistor, WDO	1	10	100	kΩ
I _{WDO}	Watchdog output current			10	mA
T _J	Junction Temperature	-40		125	°C

(1) Using a C_{CRST} capacitor of 0.1 nF or 1000 nF gives a reset delay of 703 μs or 3.22 seconds, respectively.

(2) Using a C_{CWD} capacitor of 0.1 nF or 1000 nF gives a t_{WDU(typ)} of 62.74 ms or 77.45 seconds, respectively.

6.4 Thermal Information

THERMAL METRIC ⁽¹⁾		TPS3430	UNIT
		DRC (VSON)	
		10 PINS	
R _{θJA}	Junction-to-ambient thermal resistance	50.9	°C/W
R _{θJC(top)}	Junction-to-case (top) thermal resistance	50.6	
R _{θJB}	Junction-to-board thermal resistance	25.4	
ψ _{JT}	Junction-to-top characterization parameter	1.2	
ψ _{JB}	Junction-to-board characterization parameter	25.5	
R _{θJC(bot)}	Junction-to-case (bottom) thermal resistance	7.3	

(1) For more information about traditional and new thermal metrics, see the *Semiconductor and IC Package Thermal Metrics* application report, [SPRA953](#).

6.5 Electrical Characteristics

at 1.6 V ≤ V_{DD} ≤ 6.5 V over the operating temperature range of –40°C ≤ T_J ≤ +125°C (unless otherwise noted); typical values are at T_J = 25°C

PARAMETER		TEST CONDITIONS	MIN	TYP	MAX	UNIT
GENERAL CHARACTERISTICS						
V _{DD1} , V _{DD2} (1) (3)	Supply voltage		1.6		6.5	V
I _{DD}	Supply current			10	19	μA
V _{POR} (2)	Power-on reset voltage	V _{OL(MAX)} = 0.25 V			0.8	V
I _{CRST}	CRST pin charge current	CRST = 0.5 V	337	375	413	nA
V _{CRST}	CRST pin threshold voltage		1.192	1.21	1.228	V
WINDOW WATCHDOG FUNCTION						
I _{CWD}	CWD pin charge current	CWD = 0.5 V	347	375	403	nA
V _{CWD}	CWD pin threshold voltage		1.196	1.21	1.224	V
V _{OL}	W _{DO} output low	V _{DD} = 5 V, I _{SINK} = 3 mA			0.4	V
I _D	W _{DO} output leakage current	V _{DD} = 1.6 V, V _{W_{DO}} = 6.5 V			1	μA
V _{IL}	Low-level input voltage (SET0, SET1)				0.25	V
V _{IH}	High-level input voltage (SET0, SET1)		0.8			V
V _{IL(WDI)}	W _{DO} output low				0.3 × V _{DD}	V
V _{IH(WDI)}	W _{DO} output leakage current		0.8 × V _{DD}			V

- (1) When V_{DD} falls below V_{UVLO}, WDI is ignored
(2) When V_{DD} falls below V_{POR}, W_{DO} is undefined.
(3) During power-on, V_{DD} must be a minimum 1.6 V for at least 300 μs.

6.6 Timing Requirements

at $1.6\text{ V} \leq V_{DD} \leq 6.5\text{ V}$ over the operating temperature range of $-40^\circ\text{C} \leq T_A, T_J \leq +125^\circ\text{C}$ (unless otherwise noted); the open-drain pullup resistors are $10\text{ k}\Omega$ for each output; typical values are at $T_J = 25^\circ\text{C}$

			MIN	TYP	MAX	UNIT
GENERAL						
t_{INIT}	CWD, CRST pin evaluation period ⁽¹⁾			381		μs
t_{SET}	Time required between changing SET0 and SET1 pins			500		μs
	SET0, SET1 pin setup time			1		μs
	Startup delay ⁽³⁾			300		μs
DELAY FUNCTION						
t_{RST}	Watchdog reset delay	CRST = NC	170	200	230	ms
		CRST = $10\text{ k}\Omega$ to VDD	8.5	10	11.5	ms
WINDOW WATCHDOG FUNCTION						
WD ratio	Window watchdog ratio of lower boundary to upper boundary	CWD = programmable, SET0 = 0, SET1 = 0 ⁽²⁾	1/8			
		CWD = programmable, SET0 = 1, SET1 = 1 ⁽²⁾	1/2			
		CWD = programmable, SET0 = 0, SET1 = 1 ^{(2) (4)}	3/4			
t_{WDL}	Window watchdog lower boundary	CWD = NC, SET0 = 0, SET1 = 0	19.1	22.5	25.9	ms
		CWD = NC, SET0 = 0, SET1 = 1	1.48	1.85	2.22	ms
		CWD = NC, SET0 = 1, SET1 = 0	Watchdog disabled			
		CWD = NC, SET0 = 1, SET1 = 1	680	800	920	ms
		CWD = $10\text{ k}\Omega$ to VDD, SET0 = 0, SET1 = 0	7.65	9.0	10.35	ms
		CWD = $10\text{ k}\Omega$ to VDD, SET0 = 0, SET1 = 1	7.65	9.0	10.35	ms
		CWD = $10\text{ k}\Omega$ to VDD, SET0 = 1, SET1 = 0	Watchdog disabled			
		CWD = $10\text{ k}\Omega$ to VDD, SET0 = 1, SET1 = 1	1.48	1.85	2.22	ms
t_{WDU}	Window watchdog upper boundary	CWD = NC, SET0 = 0, SET1 = 0	46.8	55.0	63.3	ms
		CWD = NC, SET0 = 0, SET1 = 1	23.375	27.5	31.625	ms
		CWD = NC, SET0 = 1, SET1 = 0	Watchdog disabled			
		CWD = NC, SET0 = 1, SET1 = 1	1360	1600	1840	ms
		CWD = $10\text{ k}\Omega$ to VDD, SET0 = 0, SET1 = 0	92.7	109.0	125.4	ms
		CWD = $10\text{ k}\Omega$ to VDD, SET0 = 0, SET1 = 1	165.8	195.0	224.3	ms
		CWD = $10\text{ k}\Omega$ to VDD, SET0 = 1, SET1 = 0	Watchdog disabled			
		CWD = $10\text{ k}\Omega$ to VDD, SET0 = 1, SET1 = 1	9.35	11.0	12.65	ms
$t_{\text{WD-setup}}$	Setup time required for device to respond to changes on WDI after being enabled		150			μs
	Minimum WDI pulse duration		50			ns
$t_{\text{WD-del}}$	WDI to $\overline{\text{WDO}}$ delay		50			ns

(1) Refer to [§ 8.1.2.2](#)

(2) 0 refers to $V_{\text{SET}} \leq V_{\text{IL}}$, 1 refers to $V_{\text{SET}} \geq V_{\text{IH}}$.

(3) During power-on, VDD must be a minimum 1.6 V for at least 300 μs

(4) If this watchdog ratio is used, then $t_{\text{WDL}}(\text{max})$ can overlap $t_{\text{WDU}}(\text{min})$.

6.7 Timing Diagrams

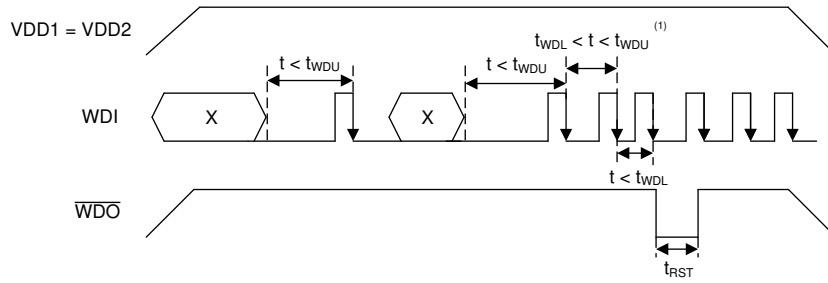

A. See 图 6-2 for WDI timing requirements.

图 6-1. Timing Diagram



图 6-2. TPS3430 Window Watchdog Timing



图 6-3. Changing SET0 and SET1 Pins

6.8 Typical Characteristics

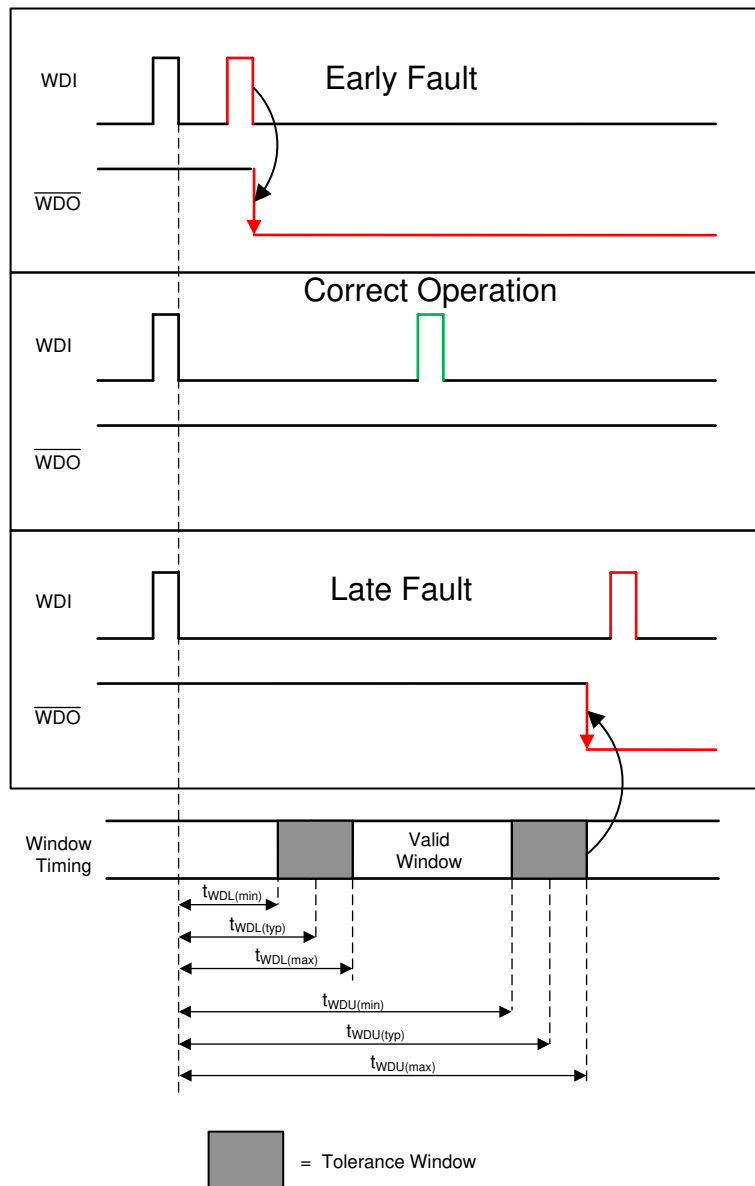
all curves are taken at $T_A = 25^\circ\text{C}$ with $1.6\text{ V} \leq V_{DD} \leq 6.5\text{ V}$ (unless otherwise noted)

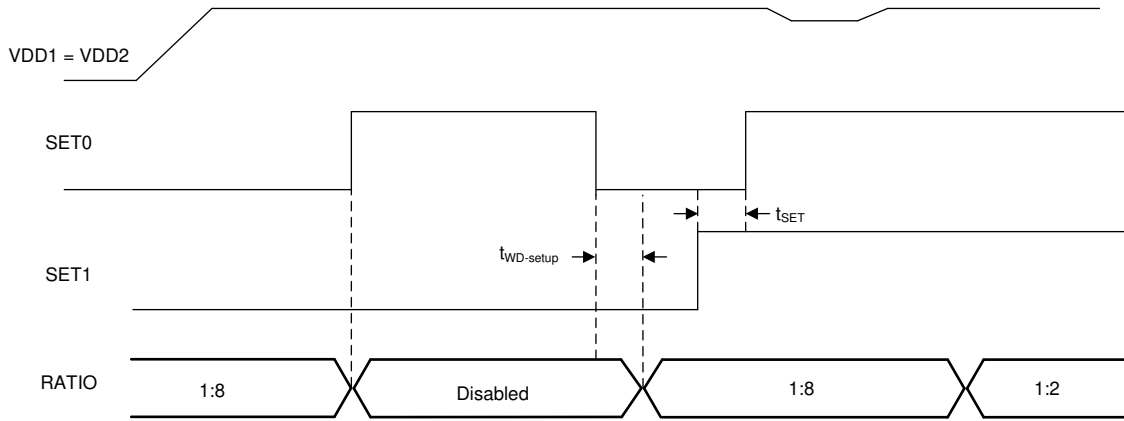

图 6-4. CWD Charging Current vs Temperature



图 6-5. Supply Current vs Power-Supply Voltage

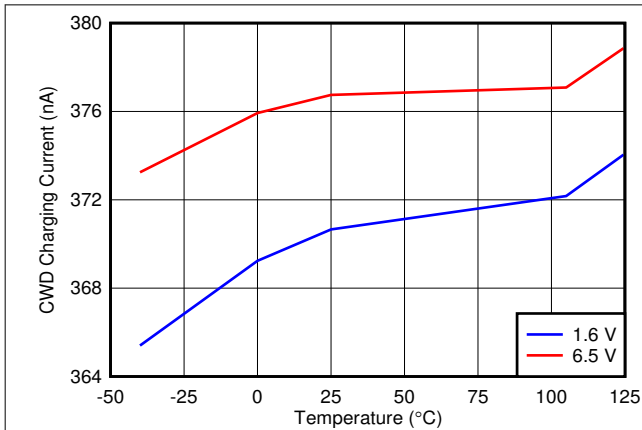

图 6-6. Normalized Watchdog Timeout Accuracy Over Temperature (SET0 = 1, SET1 = 1, CWD = NC)

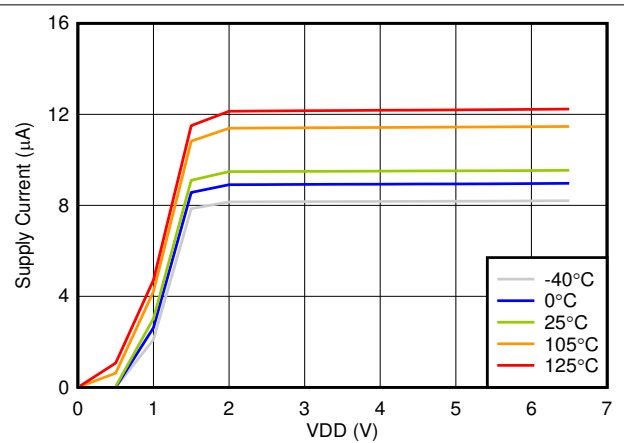

图 6-7. Normalized Watchdog Timeout Accuracy Over Temperature (SET0 = 1, SET1 = 1, CWD = 10kΩ to VDD)

7 Detailed Description

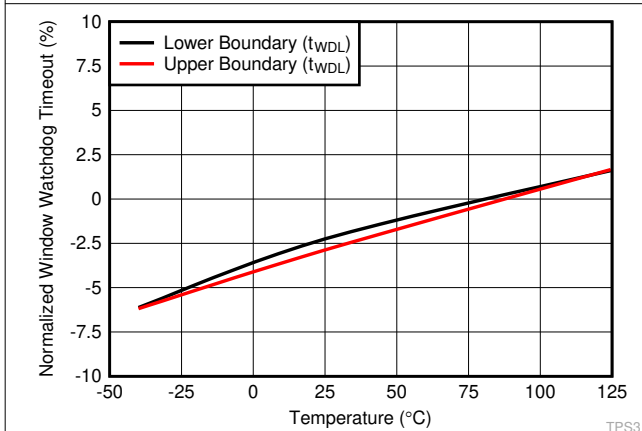
7.1 Overview

The TPS3430 is a high-accuracy programmable window watchdog timer with watchdog disable feature that achieves 15% watchdog timing accuracy over the specified temperature range of -40°C to $+125^{\circ}\text{C}$.

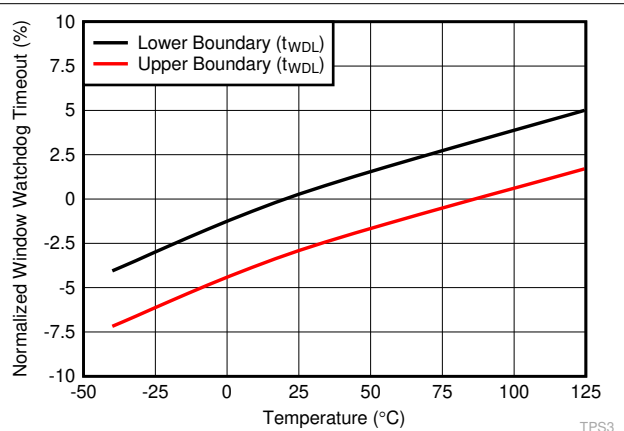
7.2 Functional Block Diagrams

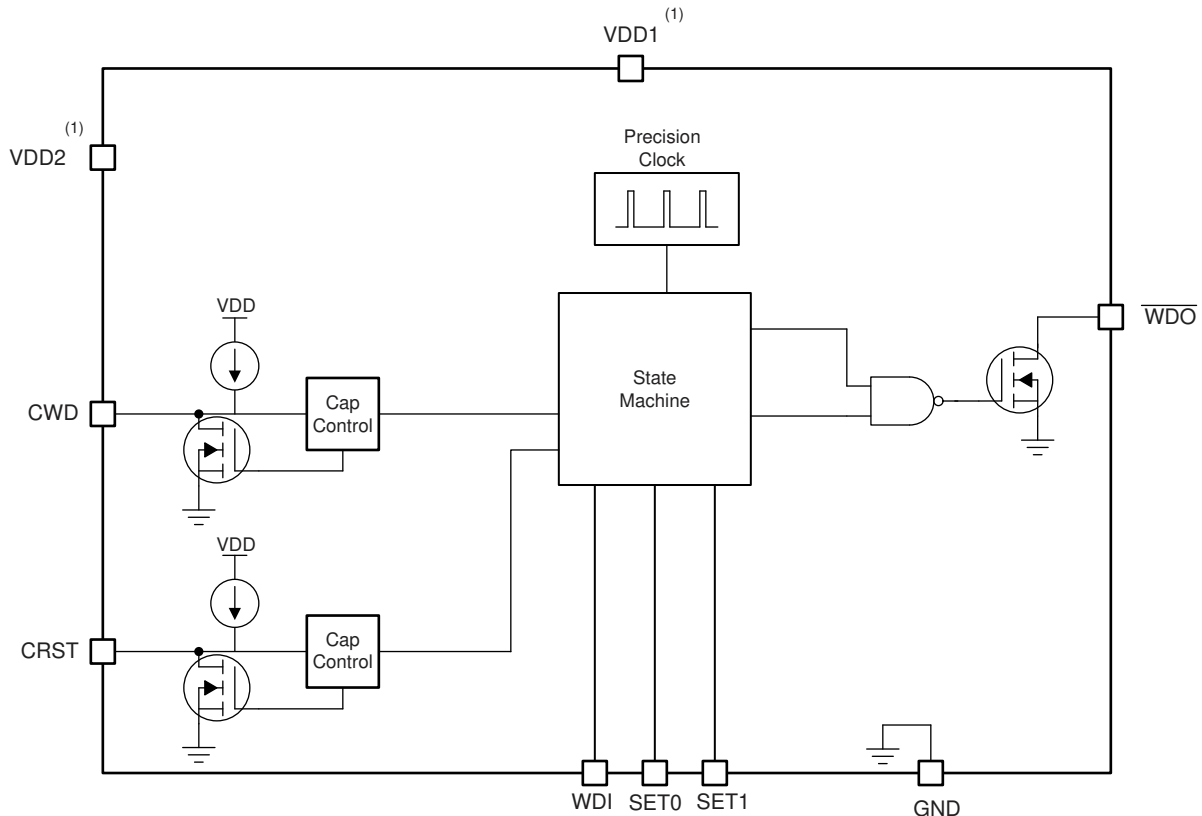

A. VDD1 and VDD2 are not internally connected and must be connected externally for the device to function.

图 7-1. TPS3430 Block Diagram

7.3 Feature Description

7.3.1 CRST

The CRST pin provides the user the functionality of both high-precision, factory-programmed watchdog reset delay timing options and user-programmable watchdog reset delay timing. The CRST pin can be pulled up to VDD through a resistor, have an external capacitor to ground, or can be left unconnected. The configuration of the CRST pin is re-evaluated by the device every time the voltage on VDD comes up. The pin evaluation is controlled by an internal state machine that determines which option is connected to the CRST pin. The sequence of events takes $381\ \mu\text{s}$ (t_{INIT}) to determine if the CRST pin is left unconnected, pulled up through a resistor, or connected to a capacitor. If the CRST pin is being pulled up to VDD, then a 10-k Ω pull-up resistor is required.

7.3.2 Window Watchdog

7.3.2.1 SET0 and SET1

When changing the SET0 or SET1 pins, there are two cases to consider: enabling and disabling the watchdog, and changing the SET0 or SET1 pins when the watchdog is enabled. In case 1 where the watchdog is being enabled or disabled, the changes take effect immediately. However, in case 2, a WDO fault event must occur in order for the changes to take place.

7.3.2.1.1 Enabling the Window Watchdog

The TPS3430 features the ability to enable and disable the watchdog timer. This feature allows the user to start with the watchdog timer disabled and then enable the watchdog timer using the SET0 and SET1 pins. The ability to enable and disable the watchdog is useful to avoid undesired watchdog trips during initialization and shutdown. When the SETx pins are changed to disable the watchdog timer, changes on the pins are responded to immediately (as shown in 图 7-2). When the watchdog goes from disabled to enabled, there is a 150 μs ($t_{\text{WD-setup}}$) transition period where the device does not respond to changes on WDI. After this 150- μs period, the device begins to respond to changes on WDI again.



图 7-2. Enabling the Watchdog Timer

7.3.2.1.2 Disabling the Watchdog Timer When Using the CRST Capacitor

When using the TPS3430 with fixed timing options, if the watchdog is disabled and reenabled while $\overline{\text{WDO}}$ is asserted (logic low) the watchdog performs as described in the 7.3.2.1.1 section. However, if there is a capacitor on the CRST pin, and the watchdog is disabled and reenabled when $\overline{\text{WDO}}$ is asserted (logic low), then the watchdog behaves as shown in 图 7-3. When the watchdog is disabled, $\overline{\text{WDO}}$ goes high impedance (logic high). However, when the watchdog is enabled again, the t_{RST} period must expire before the watchdog resumes normal operation.

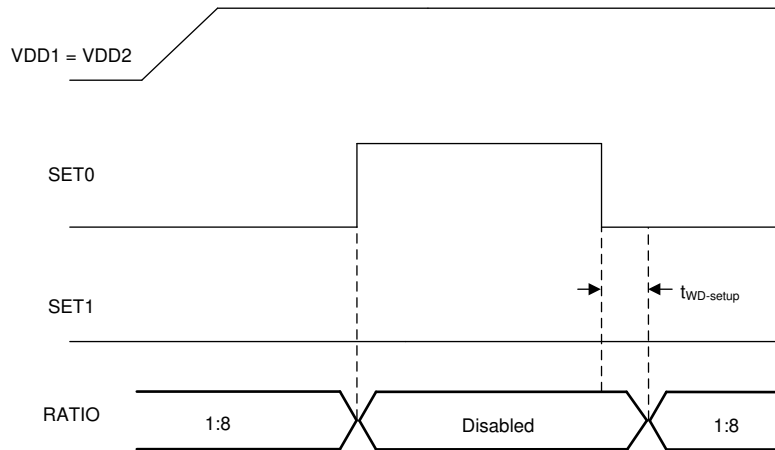
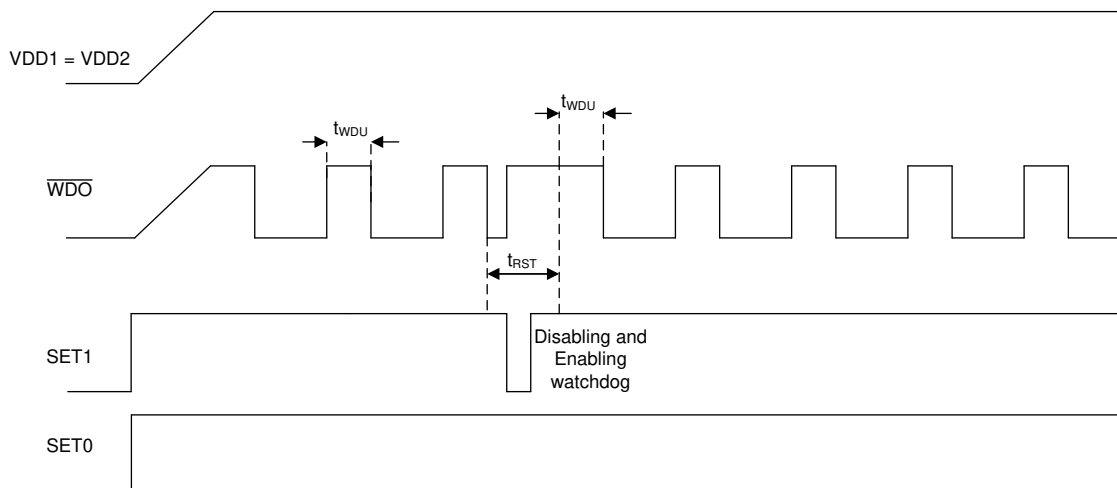

There is no WDI signal in this figure, WDI is always at GND.

图 7-3. Enabling and Disabling the Watchdog Timer During a WDO Reset Event

7.3.2.1.3 SET0 and SET1 During Normal Watchdog Operation

The SET0 and SET1 pins can be used to control the window watchdog ratio of the lower boundary to the upper boundary. There are four possible modes for the watchdog (see 表 8-5): disabled, 1:8 ratio, 3:4 ratio, and 1:2 ratio. If SET0 = 1 and SET1 = 0, then the watchdog is disabled. When the watchdog is disabled \overline{WDO} does not assert, and the TPS3430 ignores all inputs to WDI. The SET0 and SET1 pins can be changed when the device is operational, but cannot be changed at the same time. If these pins are changed when the device is operational, then there must be a 500- μ s (t_{SET}) delay between switching the two pins. If the SET0 and SET1 are used to change the reset timing, then a reset event must occur before the new timing condition is latched. This reset can be triggered by bringing VDD below V_{UVLO} . 图 7-4 shows how the SET0 and SET1 pins do not change the watchdog timing option until a reset event has occurred.



图 7-4. Changing SET0 and SET1 Pins

7.3.3 Window Watchdog Timer

This section provides information for the window watchdog modes of operation. A window watchdog is typically employed in safety critical applications where a traditional watchdog timer is inadequate. In a traditional watchdog, there is a maximum time in which a pulse must be issued to prevent the reset from occurring. However, in a window watchdog the pulse must be issued between a maximum lower window time ($t_{WDL(max)}$) and the minimum upper window time ($t_{WDU(min)}$) set by the CWD pin and the SET0 and SET1 pins. 表 8-5 describes how t_{WDU} can be used to calculate the timing of t_{WDL} . The t_{WDL} timing can also be changed by adjusting the SET0 and SET1 pins. 图 7-5 shows the valid region for a WDI pulse to be issued to prevent the WDO from being triggered and being pulled low.

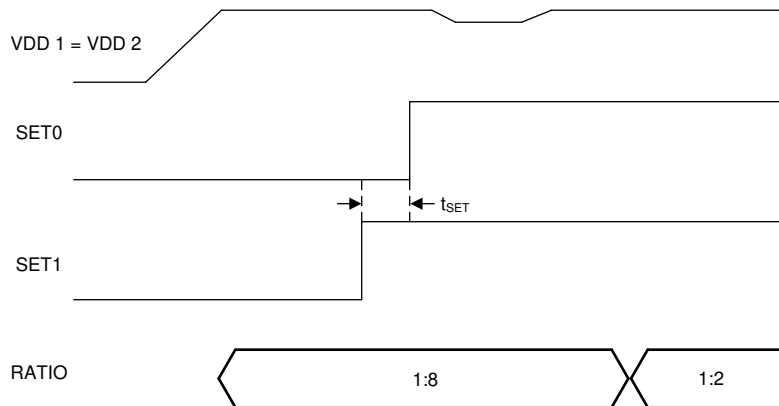

图 7-5. TPS3430 Window Watchdog Timing

7.3.3.1 CWD

The CWD pin provides the user the functionality of both high-precision, factory-programmed watchdog timeout options and user-programmable watchdog timeout. The TPS3430 features three options for setting the watchdog window: connecting a capacitor to the CWD pin, connecting CWD to a pull-up resistor to VDD, and leaving the CWD pin unconnected. The configuration of the CWD pin is evaluated by the device every time the voltage on VDD rises above $V_{DD(min)}$. The pin evaluation is controlled by an internal state machine that determines which option is connected to the CWD pin. The sequence of events takes 381 μ s (t_{INIT}) to determine if the CWD pin is left unconnected, pulled up through a resistor, or connected to a capacitor. If the CWD pin is being pulled up to VDD using a pull-up resistor, then a 10-k Ω resistor is required.

7.3.3.2 WDI Functionality

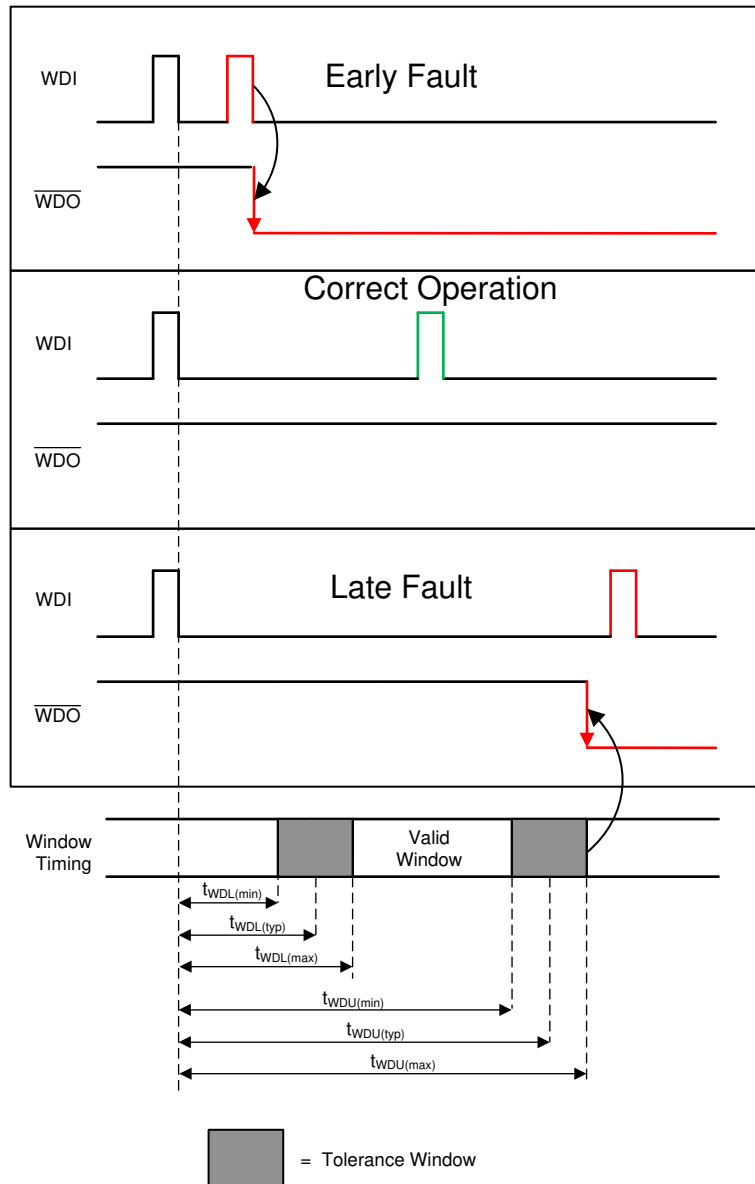
WDI is the watchdog timer input that controls the \overline{WDO} output. The WDI input is triggered by the falling edge of the input signal. For the first pulse, the watchdog acts as a traditional watchdog timer; thus, the first pulse must be issued before $t_{WDU(min)}$. After the first pulse, to ensure proper functionality of the watchdog timer, always issue the WDI pulse within the window of $t_{WDL(max)}$ and $t_{WDU(min)}$. If the pulse is issued in this region, then \overline{WDO} remains unasserted. Otherwise, the device asserts \overline{WDO} , putting the \overline{WDO} pin into a low-impedance state.

The watchdog input (WDI) is a digital pin. To ensure there is no increase in I_{DD} , drive the WDI pin to either VDD or GND at all times. Putting the pin to an intermediate voltage can cause an increase in supply current (I_{DD}) because of the architecture of the digital logic gates. When \overline{WDO} is asserted, the watchdog is disabled and all signals input to WDI are ignored until the \overline{WDO} reset delay expires. When \overline{WDO} is no longer asserted, the device resumes normal operation and no longer ignores the signal on WDI. If the watchdog is disabled, drive the WDI pin to either VDD or GND.

7.3.3.3 \overline{WDO} Functionality

The TPS3430 features a programmable window watchdog timer with an programmable watchdog output (\overline{WDO}). The watchdog output can flag a fault whenever the watchdog input is outside of the watchdog window. When \overline{WDO} is not asserted (high), the \overline{WDO} signal maintains normal operation. When asserted, \overline{WDO} remains down for t_{RST} and WDI is ignored during the watchdog reset delay. When the watchdog is disabled, \overline{WDO} remains high regardless of WDI.

7.4 Device Functional Modes

表 7-1 summarizes the functional modes of the TPS3430.

表 7-1. Device Functional Modes

VDD	WDI	WDO
$V_{DD} < V_{POR}$	—	—
$V_{POR} < V_{DD} < V_{DD (min)}$	Ignored	High
$V_{DD} \geq V_{DD (min)}$	$t_{WDL(max)} \leq t_{pulse}^{(1)} \leq t_{WDU(min)}$	High
	$t_{WDL(max)} > t_{pulse}^{(1)}$	Low
	$t_{WDU(min)} < t_{pulse}^{(1)}$	Low

(1) Where t_{pulse} is the time between falling edges on WDI.

7.4.1 VDD is Below VPOR ($V_{DD} < V_{POR}$)

When V_{DD} is less than V_{POR} , \overline{WDO} is undefined and can be either high or low. The state of \overline{WDO} largely depends on the load that the \overline{WDO} pin is experiencing.

7.4.2 VDD is Above VPOR And Below VDD (min) ($V_{POR} < V_{DD} < V_{DD (min)}$)

When V_{DD} is above V_{POR} and below $V_{DD (min)}$, the watchdog is disabled, \overline{WDO} is logic high and WDI is ignored.

7.4.3 Normal Operation ($V_{DD} \geq V_{DD (min)}$)

When V_{DD} is greater than or equal to $V_{DD (min)}$, the \overline{WDO} signal is determined by WDI if the watchdog is enabled. During power up, the watchdog is disabled until t_{RST} expires. While the watchdog is enabled, the first falling edge on WDI must occur before $t_{WDU(max)}$ to prevent \overline{WDO} from asserting. If the first falling edge on WDI occurs after $t_{WDU(max)}$, \overline{WDO} is asserted (active and low) for t_{RST} . If any falling edge after the first falling edge occurs on WDI before $t_{WDU(min)}$ or after $t_{WDU(max)}$, \overline{WDO} is asserted (active and low) for t_{RST} .

8 Application and Implementation

Note

以下应用部分中的信息不属于 TI 器件规格的范围，TI 不担保其准确性和完整性。TI 的客户应负责确定器件是否适用于其应用。客户应验证并测试其设计，以确保系统功能。

8.1 Application Information

The following sections describe in detail proper device implementation, depending on the final application requirements.

8.1.1 CRST Delay

The TPS3430 features three options for setting the reset delay (t_{RST}): connecting a capacitor to the CRST pin, connecting a pull-up resistor to VDD, and leaving the CRST pin unconnected. 图 8-1 shows a schematic drawing of all three options. To determine which option is connected to the CRST pin, an internal state machine controls the internal pulldown device and measures the pin voltage. This sequence of events takes 381 μs (t_{INIT}) to determine which timing option is used. Every time \overline{WDO} is asserted, the state machine determines what is connected to the pin.



图 8-1. CRST Charging Circuit

8.1.1.1 Factory-Programmed Watchdog Reset Delay Timing

To use the factory-programmed timing options, the CRST pin must either be left unconnected or pulled up to VDD through a 10-k Ω pull-up resistor. Using these options enables a high-precision, 15% accurate reset delay timing, as shown in 表 8-1.

表 8-1. Watchdog Reset Delay Time for Factory-Programmed Timing

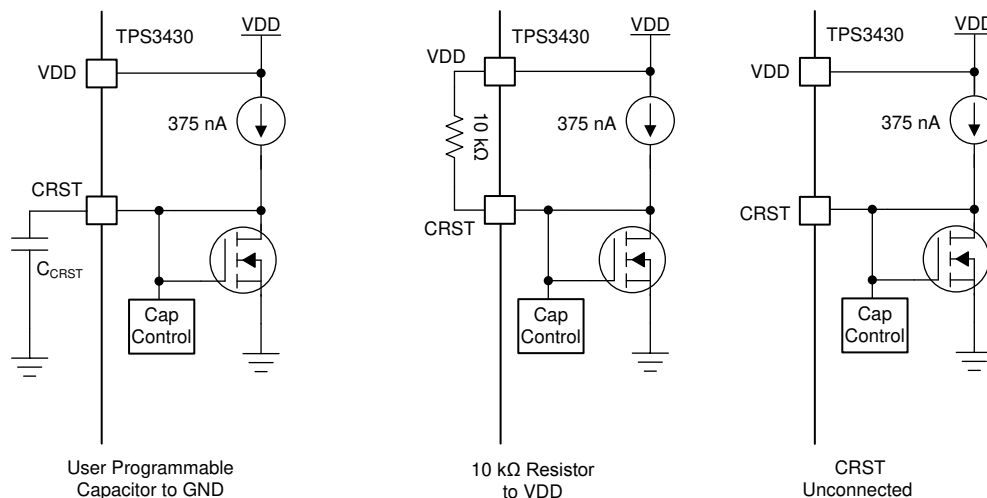
CRST	WDO DELAY TIME (t_{RST})			UNIT
	MIN	TYP	MAX	
NC	170	200	230	ms
10 k Ω to VDD	8.5	10	11.5	ms

8.1.1.2 CRST Programmable Watchdog Reset Delay

The TPS3430 uses a CRST pin charging current (I_{CRST}) of 375 nA. When using an external capacitor, the rising \overline{WDO} delay time can be set to any value between 700 μs ($C_{CRST} = 100 \text{ pF}$) and 3.2 seconds ($C_{CRST} = 1 \text{ }\mu\text{F}$). The typical ideal capacitor value needed for a given delay time can be calculated using 方程式 1, where C_{CRST} is in microfarads and t_{RST} is in seconds:

$$t_{RST} = 3.22 \times C_{CRST} + 0.000381 \quad (1)$$

To calculate the minimum and maximum watchdog reset delay time use [方程式 2](#) and [方程式 3](#), respectively.

$$t_{RST(min)} = 2.8862 \times C_{CRST} + 0.000324 \quad (2)$$

$$t_{RST(max)} = 3.64392 \times C_{CRST} + 0.000438 \quad (3)$$

The slope of [方程式 1](#) is determined by the time the CRST charging current (I_{CRST}) takes to charge the external capacitor up to the CRST comparator threshold voltage (V_{CRST}). When \overline{WDO} is asserted, the capacitor is discharged through the internal CRST pulldown resistor. When the \overline{WDO} conditions are cleared, the internal precision current source is enabled and begins to charge the external capacitor; when $V_{CRST} = 1.21\text{ V}$, \overline{WDO} is unasserted. Note to minimize the difference between the calculated \overline{WDO} delay time and the actual \overline{WDO} delay time, use a high-quality ceramic dielectric COG, X5R, or X7R capacitor and minimize parasitic board capacitance around this pin. [表 8-2](#) lists the watchdog reset delay time ideal capacitor values for C_{CRST} .

表 8-2. Watchdog Reset Delay Time for Common Ideal Capacitor Values

C_{CRST}	WDO DELAY TIME (t_{RST})			UNIT
	MIN ⁽¹⁾	TYP	MAX ⁽¹⁾	
100 pF	0.61	0.70	0.80	ms
1 nF	3.21	3.61	4.08	ms
10 nF	29.2	32.6	36.8	ms
100 nF	289	323	364	ms
1 μF	2886	3227	3644	ms

(1) Minimum and maximum values are calculated using ideal capacitors.

8.1.2 CWD Functionality

The TPS3430 features three options for setting the watchdog window: connecting a capacitor to the CWD pin, connecting a pull-up resistor to VDD, and leaving the CWD pin unconnected. [图 8-2](#) shows a schematic drawing of all three options. If this pin is connected to VDD through a 10-k Ω pull-up resistor or left unconnected (high impedance), then the factory-programmed watchdog timeouts are enabled; see the [表 6.6](#) table. Otherwise, the watchdog timeout can be adjusted by placing a capacitor from the CWD pin to ground.



图 8-2. CWD Charging Circuit

8.1.2.1 Factory-Programmed Timing Options

If using the factory-programmed timing options (listed in 表 8-3), the CWD pin must either be unconnected or pulled up to VDD through a 10-kΩ pull-up resistor. Using these options enables high-precision, factory-programmed watchdog timing.

表 8-3. Factory-Programmed Watchdog Timing

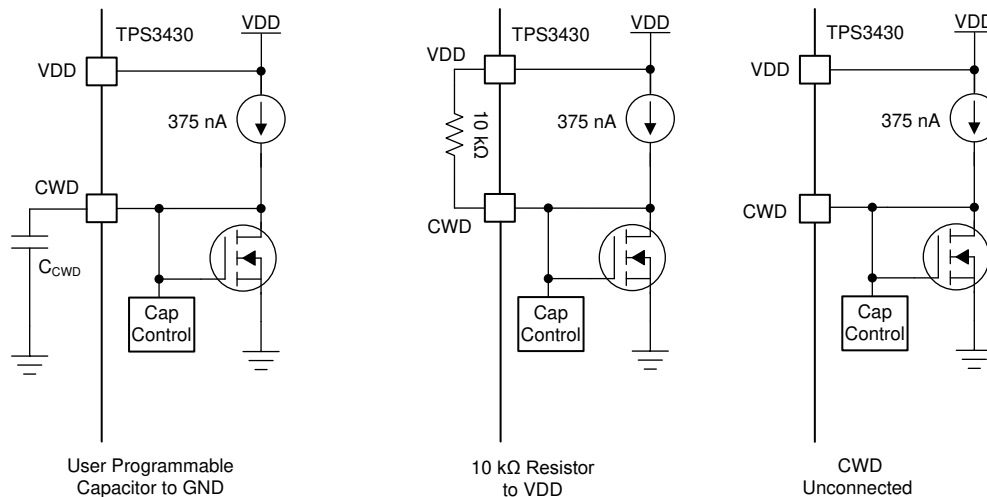
INPUT			WATCHDOG LOWER BOUNDARY (t_{WDL})			WATCHDOG UPPER BOUNDARY (t_{WDU})			UNIT
CWD	SET0	SET1	MIN	TYP	MAX	MIN	TYP	MAX	
NC	0	0	19.1	22.5	25.9	46.8	55.0	63.3	ms
	0	1	1.48	1.85	2.22	23.375	27.5	31.625	ms
	1	0	Watchdog disabled			Watchdog disabled			
	1	1	680	800	920	1360	1600	1840	ms
10 kΩ to VDD	0	0	7.65	9.0	10.35	92.7	109.0	125.4	ms
	0	1	7.65	9.0	10.35	165.8	195.0	224.3	ms
	1	0	Watchdog disabled			Watchdog disabled			
	1	1	1.48	1.85	2.22	9.35	11.0	12.65	ms

8.1.2.2 CWD Adjustable Capacitor Watchdog Timeout

Adjustable capacitor timing is achievable by connecting a capacitor to the CWD pin. If a capacitor is connected to CWD, then a 375-nA constant-current source charges C_{CWD} until $V_{CWD} = 1.21$ V. The TPS3430 determines the window watchdog upper boundary with the formula given in 方程式 4, where C_{CWD} is in microfarads and t_{WDU} is in seconds.

$$t_{WDU(\text{typ})} = 77.4 \times C_{CWD} + 0.055 \quad (4)$$

The TPS3430 is designed and tested using C_{CWD} capacitors between 100 pF and 1 μF. Note that 方程式 4 is for ideal capacitors, capacitor tolerances cause the actual device timing to vary. For the most accurate timing, use ceramic capacitors with COG dielectric material. As shown in 表 8-4, when using the minimum capacitor of 100 pF, the watchdog upper boundary is 62.74 ms; whereas with a 1-μF capacitor, the watchdog upper boundary is 77.455 seconds. If a C_{CWD} capacitor is used, 方程式 4 can be used to set t_{WDU} the window watchdog upper boundary. The window watchdog lower boundary is dependent on the SET0 and SET1 pins because these pins set the window watchdog ratio of the lower boundary to upper boundary; 表 8-5 shows how t_{WDU} can be used to calculate t_{WDL} based on the SET0 and SET1 pins.

表 8-4. t_{WDU} Values for Common Ideal Capacitor Values

C_{CWD}	WATCHDOG UPPER BOUNDARY (t_{WDU})			UNIT
	MIN ⁽¹⁾	TYP	MAX ⁽¹⁾	
100 pF	56.77	62.74	68.7	ms
1 nF	119.82	132.4	144.98	ms
10 nF	750	829	908	ms
100 nF	7054	7795	8536	ms
1 μF	70096	77455	84814	ms

(1) Minimum and maximum values are calculated using ideal capacitors.

表 8-5. Programmable CWD Timing

INPUT			WATCHDOG LOWER BOUNDARY (t_{WDL})			WATCHDOG UPPER BOUNDARY (t_{WDU})			UNIT
CWD	SET0	SET1	MIN	TYP	MAX	MIN	TYP	MAX	
C_{CWD}	0	0	$t_{WDU(\text{min})} \times 0.125$	$t_{WDU} \times 0.125$	$t_{WDU(\text{max})} \times 0.125$	$0.905 \times t_{WDU(\text{typ})}$	$t_{WDU(\text{typ})}$ ⁽¹⁾	$1.095 \times t_{WDU(\text{typ})}$	s
	0	1	$t_{WDU(\text{min})} \times 0.75$	$t_{WDU} \times 0.75$	$t_{WDU(\text{max})} \times 0.75$	$0.905 \times t_{WDU(\text{typ})}$	$t_{WDU(\text{typ})}$ ⁽¹⁾	$1.095 \times t_{WDU(\text{typ})}$	s
	1	0	Watchdog disabled			Watchdog disabled			
	1	1	$t_{WDU(\text{min})} \times 0.5$	$t_{WDU} \times 0.5$	$t_{WDU(\text{max})} \times 0.5$	$0.905 \times t_{WDU(\text{typ})}$	$t_{WDU(\text{typ})}$ ⁽¹⁾	$1.095 \times t_{WDU(\text{typ})}$	s

(1) Calculated from 方程式 4 using ideal capacitors.

8.2 Typical Applications

8.2.1 Monitoring Microcontroller with Watchdog Timer - Design 1

A basic application for the TPS3430 is shown in [Figure 8-8](#). The TPS3430 is used to monitor the activity of the microcontroller via the WDI pin. Design 1 utilizes the simplest TPS3430 configuration with factory-programmed timing options by leaving the CRST and CWD timing pins floating (NC - no connect)

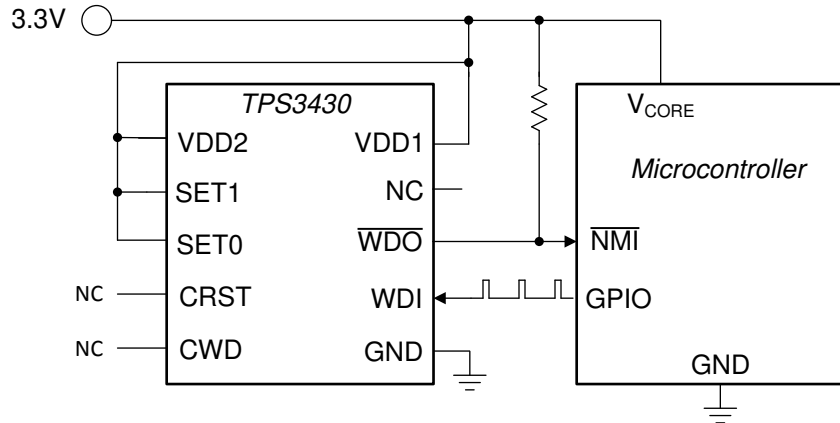

Figure 8-3. Monitoring Microcontroller using a Window Watchdog Timer

8.2.1.1 Design Requirements - Design 1

PARAMETER	DESIGN REQUIREMENT	DESIGN RESULT
Watchdog Reset delay	Reset delay of 200 ms	Use factory-programmed timing option by leaving CRST as NC. Watchdog reset delay: 170 ms (min), 200 ms (typ), 230 ms (max)
Watchdog window	Functions with a 1-Hz pulse-width modulation (PWM) signal with a 20% duty cycle	Leaving the CWD pin unconnected with SET0 = 1 and SET1 = 1 produces a window with a $t_{WDL(max)}$ of 920 ms and a $t_{WDL(min)}$ of 1360 ms
Output logic voltage	3.3-V Open-Drain	3.3-V Open-Drain
Maximum device current consumption	200 μ A	10 μ A of current consumption, typical worst-case of 199 μ A when \overline{WDO} is asserted

8.2.1.2 Detailed Design Procedure - Design 1

8.2.1.2.1 Meeting the Minimum Watchdog Reset Delay - Design 1

To achieve the 200 ms Watchdog Reset Delay requirement, this design simply leaves CRST pin floating (NC - No Connect) to set the Watchdog Reset Delay (t_{RST}) to the factory-programmed delay of 200 ms. Refer to section 8.1.1 CRST Delay to learn more about the factory-programmed timing options and how to program the Watchdog Reset Delay using an external capacitor.

In [Figure 8-4](#) below, the Watchdog Reset Delay of 200 ms is shown by causing a watchdog timing fault. No watchdog pulse comes on WDI within the Watchdog Timeout so \overline{WDO} activates for t_{RST} of 200 ms. Then after three watchdog faults, a watchdog pulse at 1Hz and 20% duty cycle arrives on WDI causing \overline{WDO} to deactivate and remain high.



图 8-4. Watchdog Fault Caused by Missing WDI Pulse Until WDI pulses Arrive Within Watchdog Window to Deactivate \overline{WDO} Fault

8.2.1.2.2 Setting the Watchdog Window - Design 1

The Watchdog Window is set via the CWD, SET0, and SET1 pin configurations. To achieve a Watchdog Timeout of 1 second, this design simply leaves CWD pin floating (NC - No Connect) and ties SET0 and SET1 to VDD to set these SET pins to logic high. With this configuration, the Watchdog Lower Boundary $t_{WDL (typ)}$ is set for 800ms and the Watchdog Upper Boundary $t_{WDU (typ)}$ is set for 1.6 seconds. Refer to Table 6.6 Timing Requirements to see the factory-programmed window watchdog timing configurations.

In [图 8-5](#) and [图 8-6](#) below, the watchdog window timing is shown by causing watchdog faults from pulses on WDI arriving too early and too late, respectively. When a pulse on WDI arrives too early, that is before $t_{WDL (min)}$ or too late, that is after $t_{WDU (max)}$, a watchdog fault occurs and \overline{WDO} activates to logic low.

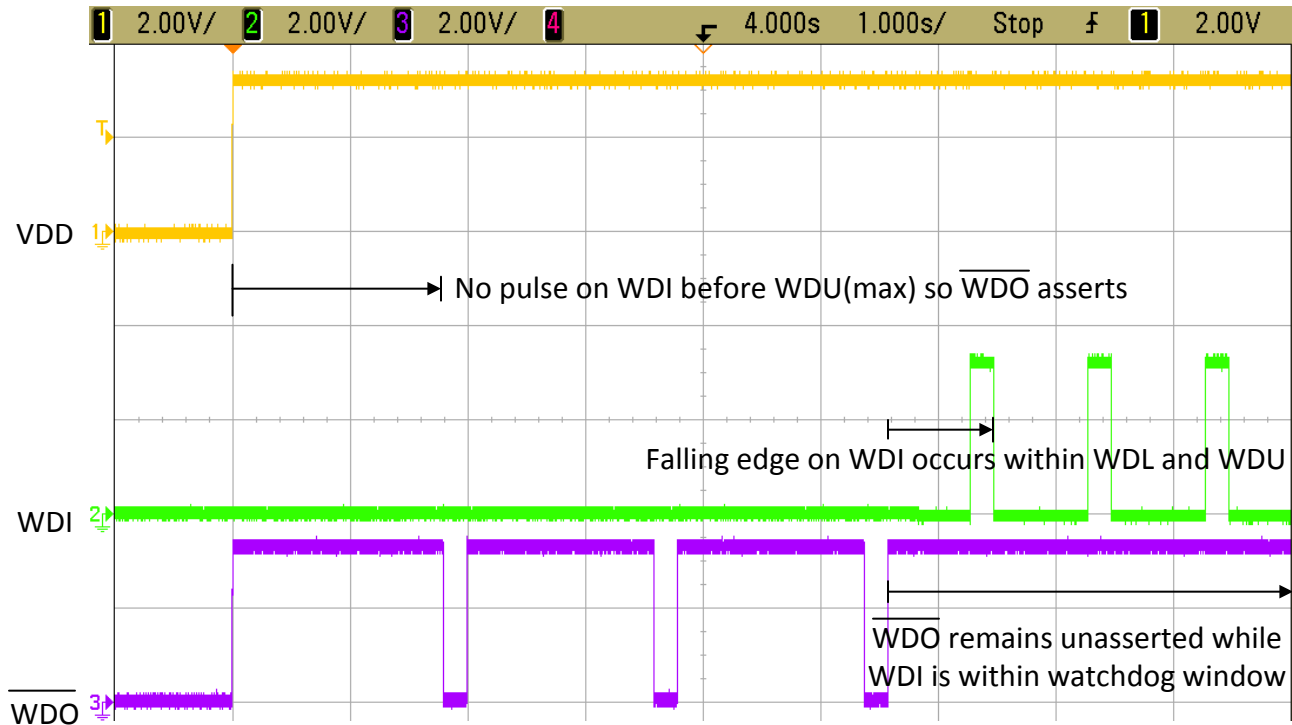

图 8-5. Watchdog Fault Caused by WDI Pulse Arriving Too Early (Before $t_{WDL}(\min)$)



图 8-6. Watchdog Fault Caused by WDI Pulse Arriving Too Late (After $t_{WDU}(\max)$)

8.2.1.2.3 Calculating the \overline{WDO} Pull-up Resistor - Design 1

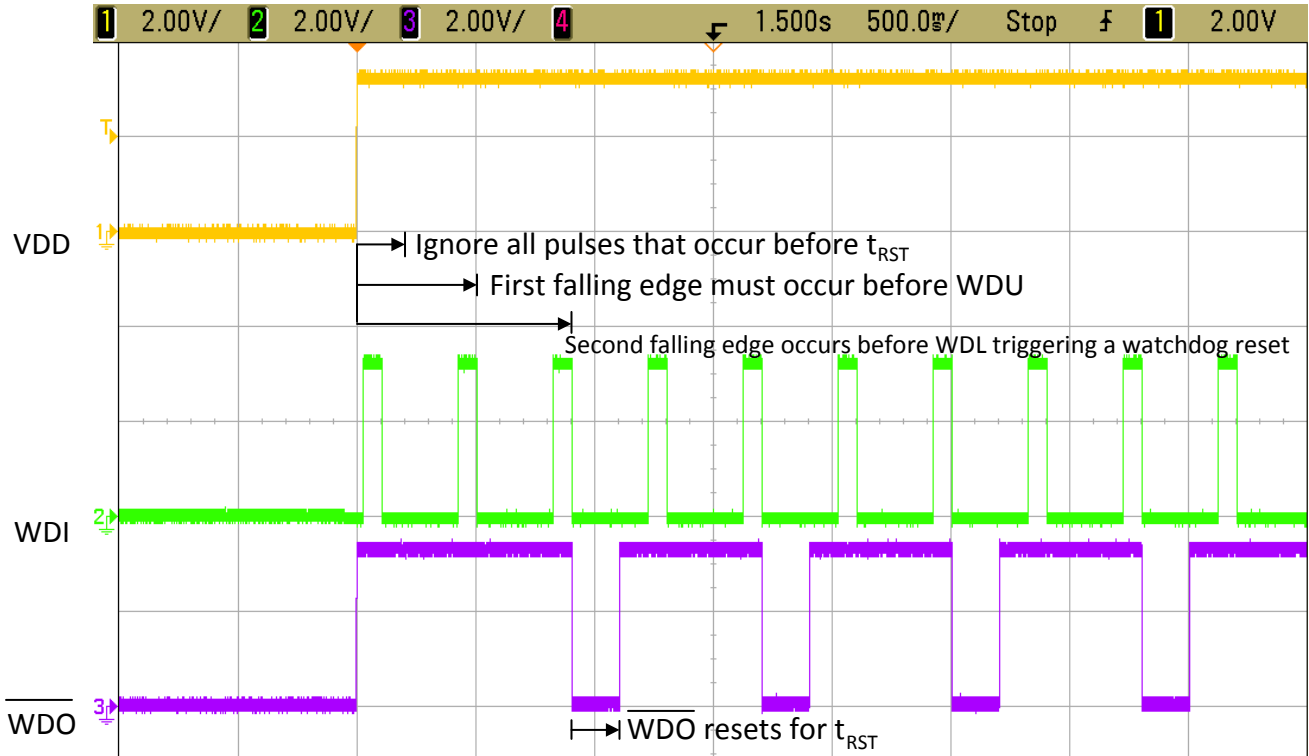
图 8-7 shows the TPS3430 uses an open-drain configuration for the \overline{WDO} circuit. When the FET is off, the resistor pulls the drain of the transistor to VDD and when the FET is turned on, the FET attempts to pull the drain to ground, thus creating an effective resistor divider. The resistors in this divider must be chosen to ensure that V_{OL} is below its maximum value. To choose the proper pull-up resistor, there are three key specifications to keep in mind: the pull-up voltage (V_{PU}), the recommended maximum \overline{WDO} pin current (I_{WDO}), and V_{OL} . The maximum V_{OL} is 0.4 V, meaning that the effective resistor divider created must be able to bring the voltage on the reset pin below 0.4 V with I_{WDO} kept below 10 mA. For this example, with a V_{PU} of 3.3 V, a resistor must be chosen to keep I_{WDO} below 200 μA because this value is the maximum consumption current allowed. To ensure this specification is met, a pull-up resistor value of 16.5 k Ω is selected, which sinks a maximum of 200 μA when \overline{WDO} is asserted. \overline{WDO} current is at 200 μA and the low-level output voltage is approximately zero.

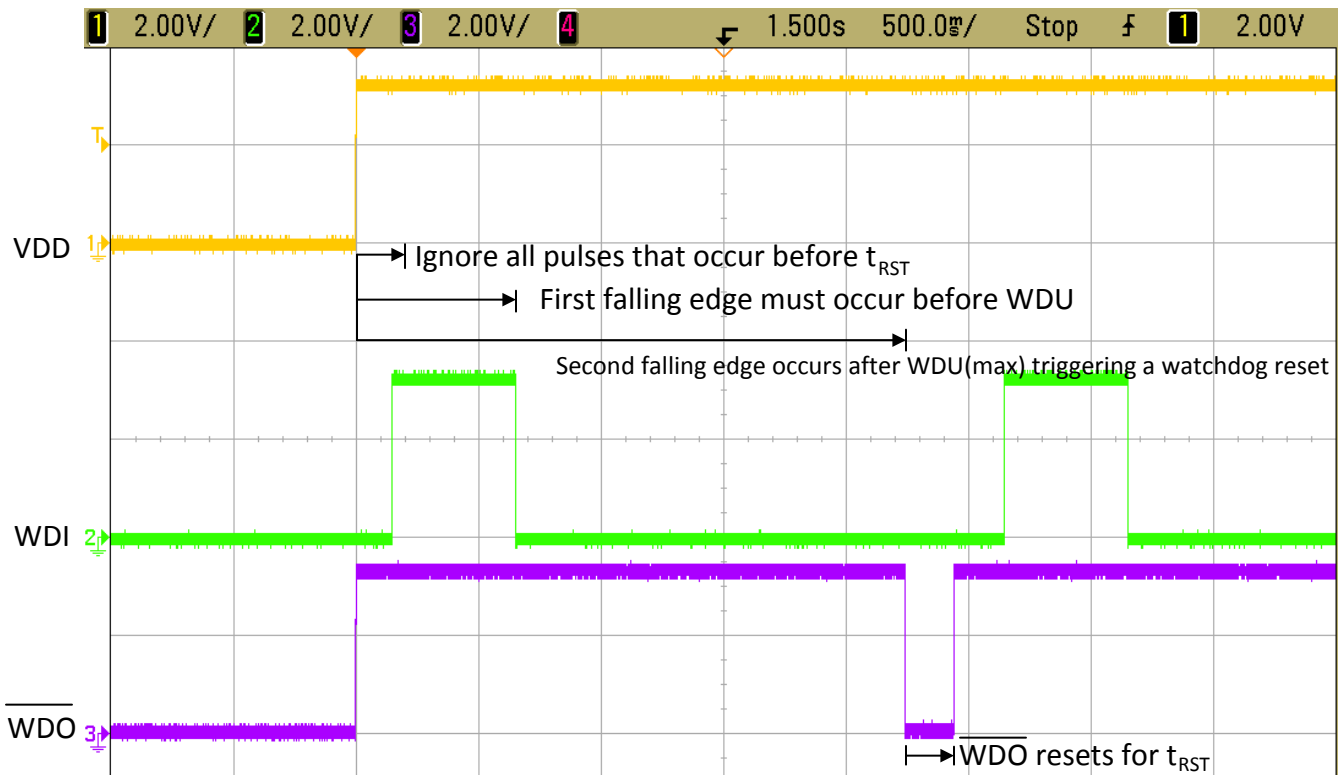

图 8-7. Open-Drain \overline{WDO} Configuration

8.2.2 Monitoring Microcontroller with a Programmed Window Watchdog Timer - Design 2

A typical application for the TPS3430 is shown in 图 8-8. The TPS3430 is used to monitor the activity of the microcontroller via the WDI pin.

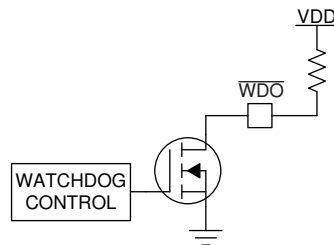

图 8-8. Monitoring Microcontroller Using a Window Watchdog Timer with Programmable Watchdog Reset Delay

8.2.2.1 Design Requirements - Design 2

PARAMETER	DESIGN REQUIREMENT	DESIGN RESULT
Watchdog Reset delay	Minimum reset delay of 250 ms	Minimum reset delay of 260 ms, reset delay of 322 ms (typical)
Watchdog window	Functions with a 30-Hz pulse-width modulation (PWM) signal with a 50% duty cycle	Leaving the CWD pin unconnected with SET0 = 0 and SET1 = 0 produces a window with a $t_{WDL(max)}$ of 25.9 ms and a $t_{WDU(min)}$ of 46.8 ms
Output logic voltage	1.8-V CMOS	1.8-V CMOS
Maximum device current consumption	200 μA	10 μA of current consumption, typical worst-case of 199 μA when \overline{WDO} is asserted

8.2.2.2 Detailed Design Procedure - Design 2

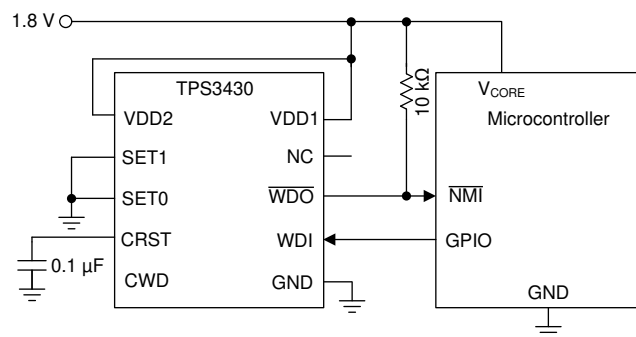
8.2.2.2.1 Meeting the Minimum Watchdog Reset Delay - Design 2

The TPS3430 features three options for setting the watchdog reset delay: connecting a capacitor to the CRST pin, connecting a pull-up resistor, and leaving the CRST pin unconnected. If the CRST pin is either unconnected or pulled up the minimum timing requirement cannot be met, thus an external capacitor must be connected to the CRST pin. Because a minimum time is required, the worst-case scenario is a supervisor with a high CRST charging current (I_{CRST}) and a low CRST comparator threshold (V_{CRST}). For applications with ambient temperatures ranging from -40°C to $+125^{\circ}\text{C}$, C_{CRST} can be calculated using $I_{CRST(MAX)}$, $V_{CRST(MIN)}$, and solving for C_{CRST} in [方程式 5](#):

$$C_{RST(MIN)} = \frac{I_{CRST(MAX)}}{V_{CRST(MIN)}} \times (t_{RST} - t_{INIT}) \quad (5)$$

When solving [方程式 5](#), the minimum capacitance required at the CRST pin is $0.086 \mu\text{F}$. If standard capacitors with $\pm 10\%$ tolerances are used, then the minimum CRST capacitor required can be found in [方程式 6](#):

$$C_{RST(min)} = \frac{C_{RST(min)_ideal}}{1 - C_{tolerance}} = \frac{0.086 \mu\text{F}}{1 - 0.1} \quad (6)$$

Solving [方程式 6](#) where $C_{tolerance}$ is 0.1 or 10%, the minimum C_{CRST} capacitor is $0.096 \mu\text{F}$. This value is then rounded up to the nearest standard capacitor value, so a $0.1\text{-}\mu\text{F}$ capacitor must be used to achieve this reset delay timing. If voltage and temperature derating are being considered, then also include these values in $C_{tolerance}$.

8.2.2.2.2 Setting the Watchdog Window - Design 2

In this application, the window watchdog timing options are based on the PWM signal that is provided to the TPS3430. A window watchdog setting must be chosen such that the falling edge of the PWM signal always falls within the window. A nominal window must be designed with $t_{WDL(max)}$ less than 33.33 ms and $t_{WDU(min)}$ greater than 33.33 ms . There are several options that satisfy this window option. An external capacitor can be placed on the CWD pin and calculated to have a sufficient window. Another option is to use one of the factory-programmed timing options. An additional advantage of choosing one of the factory-programmed options is the ability to reduce the number of components required, thus reducing overall BOM cost. Leaving the CWD pin unconnected (NC) with $SET0 = 0$ and $SET1 = 0$ produces a $t_{WDL(max)}$ of 25.9 ms and a $t_{WDU(min)}$ of 46.8 ms ; see [节 8.1.2](#).

8.2.2.2.3 Calculating the \overline{WDO} Pull-up Resistor - Design 2

The TPS3430 uses an open-drain configuration for the \overline{WDO} circuit, as shown in [图 8-7](#). When the FET is off, the resistor pulls the drain of the transistor to V_{DD} and when the FET is turned on, the FET attempts to pull the drain to ground, thus creating an effective resistor divider. The resistors in this divider must be chosen to ensure that V_{OL} is below its maximum value. To choose the proper pull-up resistor, there are three key specifications to keep in mind: the pull-up voltage (V_{PU}), the recommended maximum \overline{WDO} pin current (I_{WDO}), and V_{OL} . The maximum V_{OL} is 0.4 V , meaning that the effective resistor divider created must be able to bring the voltage on the reset pin below 0.4 V with I_{WDO} kept below 10 mA . For this example, with a V_{PU} of 1.8 V , a resistor must be chosen to keep I_{WDO} below $200 \mu\text{A}$ because this value is the maximum consumption current allowed. To ensure this specification is met, a pull-up resistor value of $10 \text{ k}\Omega$ was selected, which sinks a maximum of $180 \mu\text{A}$ when \overline{WDO} is asserted.

8.2.3 Monitoring Microcontroller with a Latching Window Watchdog Timer - Design 3

A safety critical application for the TPS3430 is shown in [图 8-9](#). The TPS3430 is used to monitor the activity of the microcontroller via the WDI pin and upon a watchdog fault, this design latches the \overline{WDO} pin until the device V_{DD} drops below $V_{DD(min)}$.



图 8-9. Monitoring Microcontroller Using a Latching Window Watchdog Timer

8.2.3.1 Design Requirements - Design 3

PARAMETER	DESIGN REQUIREMENT	DESIGN RESULT
Watchdog Reset delay	Latch \overline{WDO} upon watchdog fault	Latching watchdog functionality that keeps \overline{WDO} logic low when fault occurs
Watchdog window	Functions with a 1-Hz pulse-width modulation (PWM) signal with a 50% duty cycle	Leaving the CWD pin unconnected with SET0 = 1 and SET1 = 1 produces a window with a $t_{WDL(max)}$ of 920 ms and a $t_{WDU(min)}$ of 1360 ms
Output logic voltage	3.3-V Open-Drain	3.3-V Open-Drain
Maximum device current consumption	200 μ A	10 μ A of current consumption, typical worst-case of 199 μ A when \overline{WDO} is asserted

8.2.3.2 Detailed Design Procedure - Design 3

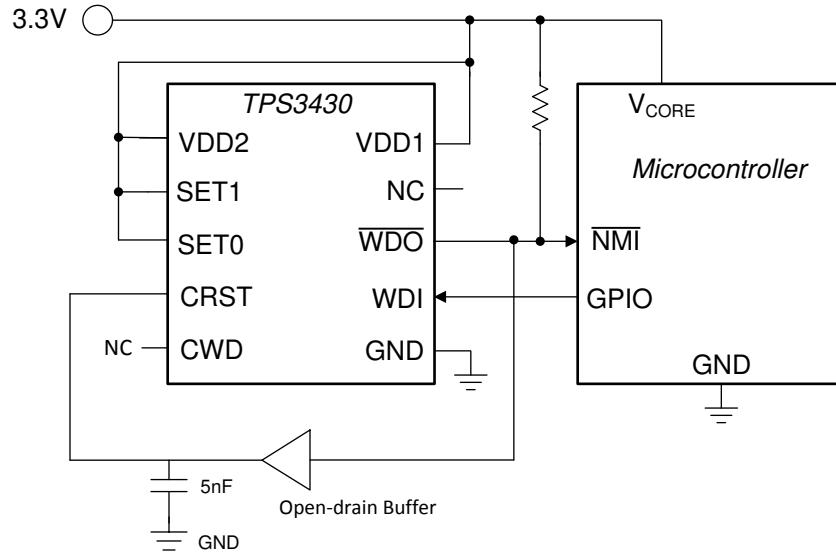
8.2.3.2.1 Meeting the Latching Output Requirement - Design 3

To achieve the latching watchdog feature, an open-drain buffer is connected from \overline{WDO} to CRST with a small value capacitor connected from the Anode of the buffer connected to CRST to GND. The capacitor must be a small value to prevent additional delay when triggering \overline{WDO} to active low during watchdog fault. A capacitor between 150 pF and 5 nF is recommended.

In [图 8-10](#) below, the latching watchdog feature is shown by causing a watchdog fault and observing \overline{WDO} . Because no pulse arrived on WDI within the Watchdog Timeout, \overline{WDO} activates and goes logic low and remains low. To reset the watchdog, the device must be restarted by dropping VDD below $V_{DD(min)}$.

8.2.3.2.2 Setting the Watchdog Window - Design 3

The Watchdog Window is set via the CWD, SET0, and SET1 pin configurations. To achieve a Watchdog Timeout of 1 second corresponding to a 1-Hz WDI signal, this design simply leaves CWD pin floating (NC - No Connect) and ties SET0 and SET1 to VDD to set the SET pins to logic high. With this configuration, the Watchdog Lower Boundary $t_{WDL(typ)}$ is set for 800 ms and the Watchdog Upper Boundary $t_{WDU(typ)}$ is set for 1.6 seconds. Refer to Table 6.6 Timing Requirements to see the factory-programmed window watchdog timing configurations.

8.2.3.3 Application Curve - Design 3



图 8-10. Watchdog Fault Caused by Missing WDI Pulse Shows \overline{WDO} Latching

9 Power Supply Recommendations

This device is designed to operate from an input supply with a voltage range between 1.6 V and 6.5 V. An input supply capacitor is not required for this device; however, if the input supply is noisy, then good analog practice is to place a 0.1- μ F capacitor between the VDD pin and the GND pin. Please be sure to externally connect VDD1 to VDD2 as the device will not function if these pins are not connected.

10 Layout

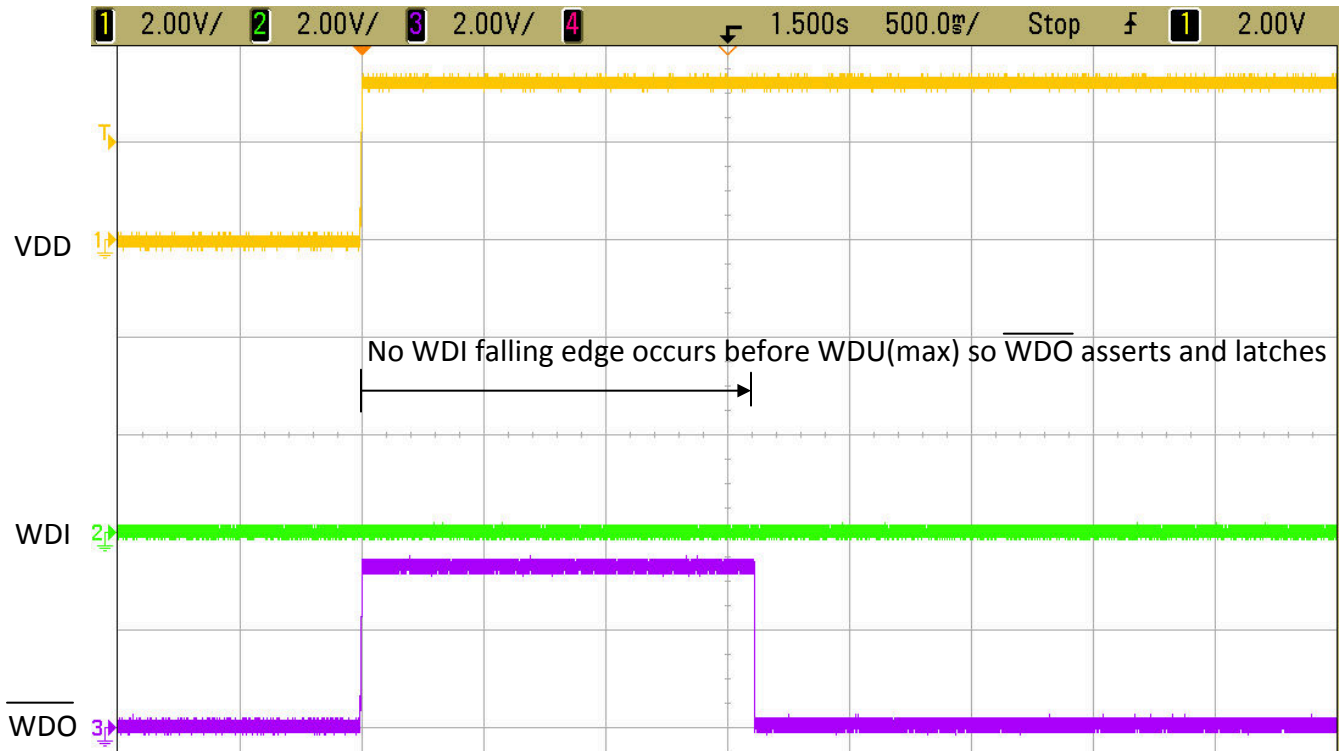
10.1 Layout Guidelines

Make sure that the connection to the VDD pin is low impedance. Good analog design practice recommends placing a 0.1- μ F ceramic capacitor as near as possible to the VDD pin. If a capacitor is not connected to the CRST pin, then minimize parasitic capacitance on this pin so the \overline{WDO} delay time is not adversely affected.

- Make sure that the connection to the VDD pin is low impedance. Good analog design practice is to place a 0.1- μ F ceramic capacitor as near as possible to the VDD pin.
- If a C_{CRST} capacitor or pull-up resistor is used, place these components as close as possible to the CRST pin. If the CRST pin is left unconnected, make sure to minimize the amount of parasitic capacitance on the pin.
- If a C_{CWD} capacitor or pull-up resistor is used, place these components as close as possible to the CWD pin. If the CWD pin is left unconnected, make sure to minimize the amount of parasitic capacitance on the pin.
- Place the pull-up resistor on \overline{WDO} as close to the pin as possible.

10.2 Layout Example



图 10-1. Typical Layout for the TPS3430

11 Device and Documentation Support

11.1 Device Support

11.2 Documentation Support

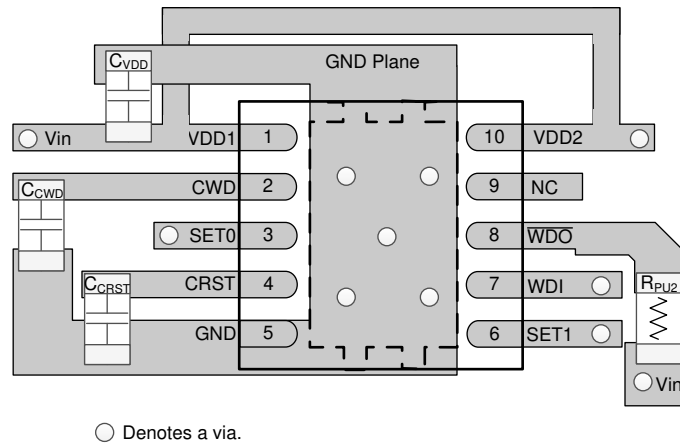
11.2.1 Related Documentation

For related documentation see the following:

- [TPS3430EVM Window Watchdog Timer with Programmable Timeout Delay User Guide](#)

11.3 接收文档更新通知

要接收文档更新通知，请导航至 ti.com 上的器件产品文件夹。点击 [订阅更新](#) 进行注册，即可每周接收产品信息更改摘要。有关更改的详细信息，请查看任何已修订文档中包含的修订历史记录。

11.4 支持资源

TI E2E™ [支持论坛](#) 是工程师的重要参考资料，可直接从专家获得快速、经过验证的解答和设计帮助。搜索现有解答或提出自己的问题可获得所需的快速设计帮助。

链接的内容由各个贡献者“按原样”提供。这些内容并不构成 TI 技术规范，并且不一定反映 TI 的观点；请参阅 TI 的《[使用条款](#)》。

11.5 Trademarks

TI E2E™ is a trademark of Texas Instruments.

所有商标均为其各自所有者的财产。

11.6 Electrostatic Discharge Caution



This integrated circuit can be damaged by ESD. Texas Instruments recommends that all integrated circuits be handled with appropriate precautions. Failure to observe proper handling and installation procedures can cause damage.

ESD damage can range from subtle performance degradation to complete device failure. Precision integrated circuits may be more susceptible to damage because very small parametric changes could cause the device not to meet its published specifications.

11.7 术语表

[TI 术语表](#) 本术语表列出并解释了术语、首字母缩略词和定义。

12 Mechanical, Packaging, and Orderable Information

The following pages include mechanical, packaging, and orderable information. This information is the most current data available for the designated devices. This data is subject to change without notice and revision of this document. For browser-based versions of this data sheet, refer to the left-hand navigation.

PACKAGING INFORMATION

Orderable part number	Status (1)	Material type (2)	Package Pins	Package qty Carrier	RoHS (3)	Lead finish/ Ball material (4)	MSL rating/ Peak reflow (5)	Op temp (°C)	Part marking (6)
TPS3430WDRCR	Active	Production	VSON (DRC) 10	3000 LARGE T&R	Yes	SN	Level-1-260C-UNLIM	-40 to 125	430AA
TPS3430WDRCR.A	Active	Production	VSON (DRC) 10	3000 LARGE T&R	Yes	SN	Level-1-260C-UNLIM	-40 to 125	430AA
TPS3430WDRCRG4	Active	Production	VSON (DRC) 10	3000 LARGE T&R	Yes	NIPDAU	Level-1-260C-UNLIM	-40 to 125	430AA
TPS3430WDRCRG4.A	Active	Production	VSON (DRC) 10	3000 LARGE T&R	Yes	NIPDAU	Level-1-260C-UNLIM	-40 to 125	430AA

(1) **Status:** For more details on status, see our [product life cycle](#).

(2) **Material type:** When designated, preproduction parts are prototypes/experimental devices, and are not yet approved or released for full production. Testing and final process, including without limitation quality assurance, reliability performance testing, and/or process qualification, may not yet be complete, and this item is subject to further changes or possible discontinuation. If available for ordering, purchases will be subject to an additional waiver at checkout, and are intended for early internal evaluation purposes only. These items are sold without warranties of any kind.

(3) **RoHS values:** Yes, No, RoHS Exempt. See the [TI RoHS Statement](#) for additional information and value definition.

(4) **Lead finish/Ball material:** Parts may have multiple material finish options. Finish options are separated by a vertical ruled line. Lead finish/Ball material values may wrap to two lines if the finish value exceeds the maximum column width.

(5) **MSL rating/Peak reflow:** The moisture sensitivity level ratings and peak solder (reflow) temperatures. In the event that a part has multiple moisture sensitivity ratings, only the lowest level per JEDEC standards is shown. Refer to the shipping label for the actual reflow temperature that will be used to mount the part to the printed circuit board.

(6) **Part marking:** There may be an additional marking, which relates to the logo, the lot trace code information, or the environmental category of the part.

Multiple part markings will be inside parentheses. Only one part marking contained in parentheses and separated by a "~" will appear on a part. If a line is indented then it is a continuation of the previous line and the two combined represent the entire part marking for that device.

Important Information and Disclaimer: The information provided on this page represents TI's knowledge and belief as of the date that it is provided. TI bases its knowledge and belief on information provided by third parties, and makes no representation or warranty as to the accuracy of such information. Efforts are underway to better integrate information from third parties. TI has taken and continues to take reasonable steps to provide representative and accurate information but may not have conducted destructive testing or chemical analysis on incoming materials and chemicals. TI and TI suppliers consider certain information to be proprietary, and thus CAS numbers and other limited information may not be available for release.

In no event shall TI's liability arising out of such information exceed the total purchase price of the TI part(s) at issue in this document sold by TI to Customer on an annual basis.

OTHER QUALIFIED VERSIONS OF TPS3430 :

- Automotive : [TPS3430-Q1](#)

NOTE: Qualified Version Definitions:

- Automotive - Q100 devices qualified for high-reliability automotive applications targeting zero defects

TAPE AND REEL INFORMATION

QUADRANT ASSIGNMENTS FOR PIN 1 ORIENTATION IN TAPE

*All dimensions are nominal

Device	Package Type	Package Drawing	Pins	SPQ	Reel Diameter (mm)	Reel Width W1 (mm)	A0 (mm)	B0 (mm)	K0 (mm)	P1 (mm)	W (mm)	Pin1 Quadrant
TPS3430WDRRCR	VSON	DRC	10	3000	330.0	12.4	3.3	3.3	1.1	8.0	12.0	Q2
TPS3430WDRCRG4	VSON	DRC	10	3000	330.0	12.4	3.3	3.3	1.1	8.0	12.0	Q2

TAPE AND REEL BOX DIMENSIONS

*All dimensions are nominal

Device	Package Type	Package Drawing	Pins	SPQ	Length (mm)	Width (mm)	Height (mm)
TPS3430WDRCR	VSON	DRC	10	3000	367.0	367.0	35.0
TPS3430WDRCRG4	VSON	DRC	10	3000	367.0	367.0	35.0

GENERIC PACKAGE VIEW

DRC 10

VSON - 1 mm max height

3 x 3, 0.5 mm pitch

PLASTIC SMALL OUTLINE - NO LEAD

This image is a representation of the package family, actual package may vary.
Refer to the product data sheet for package details.

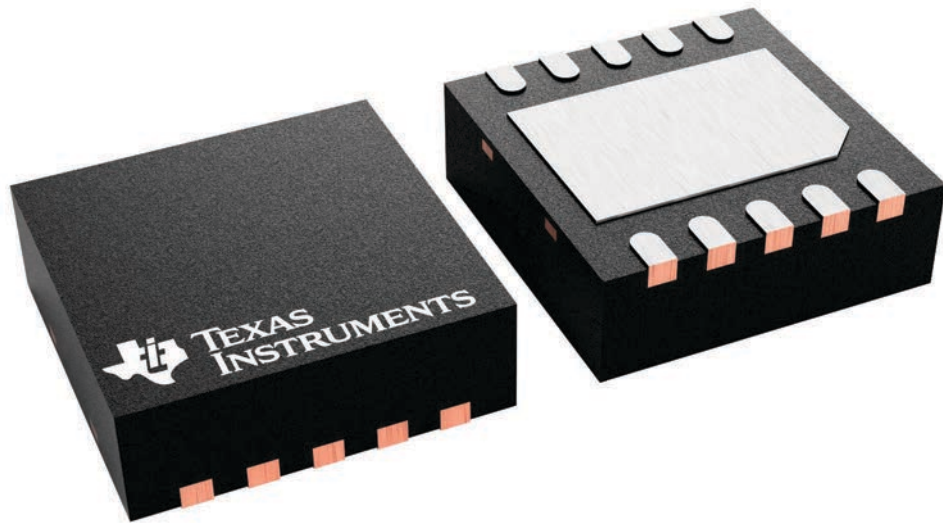

4226193/A

EXAMPLE BOARD LAYOUT

DRC0010J

VSON - 1 mm max height

PLASTIC SMALL OUTLINE - NO LEAD



LAND PATTERN EXAMPLE
EXPOSED METAL SHOWN
SCALE:20X



SOLDER MASK DETAILS

4218878/B 07/2018

NOTES: (continued)

4. This package is designed to be soldered to a thermal pad on the board. For more information, see Texas Instruments literature number SLUA271 (www.ti.com/lit/sluea271).
5. Vias are optional depending on application, refer to device data sheet. If any vias are implemented, refer to their locations shown on this view. It is recommended that vias under paste be filled, plugged or tented.

EXAMPLE STENCIL DESIGN

DRC0010J

VSON - 1 mm max height

PLASTIC SMALL OUTLINE - NO LEAD



SOLDER PASTE EXAMPLE
BASED ON 0.125 mm THICK STENCIL

EXPOSED PAD 11:
80% PRINTED SOLDER COVERAGE BY AREA
SCALE:25X

4218878/B 07/2018

NOTES: (continued)

6. Laser cutting apertures with trapezoidal walls and rounded corners may offer better paste release. IPC-7525 may have alternate design recommendations.

重要通知和免责声明

TI“按原样”提供技术和可靠性数据（包括数据表）、设计资源（包括参考设计）、应用或其他设计建议、网络工具、安全信息和其他资源，不保证没有瑕疵且不做任何明示或暗示的担保，包括但不限于对适销性、与某特定用途的适用性或不侵犯任何第三方知识产权的暗示担保。

这些资源可供使用 TI 产品进行设计的熟练开发人员使用。您将自行承担以下全部责任：(1) 针对您的应用选择合适的 TI 产品，(2) 设计、验证并测试您的应用，(3) 确保您的应用满足相应标准以及任何其他安全、安保法规或其他要求。

这些资源如有变更，恕不另行通知。TI 授权您仅可将这些资源用于研发本资源所述的 TI 产品的相关应用。严禁以其他方式对这些资源进行复制或展示。您无权使用任何其他 TI 知识产权或任何第三方知识产权。对于因您对这些资源的使用而对 TI 及其代表造成的任何索赔、损害、成本、损失和债务，您将全额赔偿，TI 对此概不负责。

TI 提供的产品受 [TI 销售条款](#)、[TI 通用质量指南](#) 或 [ti.com](#) 上其他适用条款或 TI 产品随附的其他适用条款的约束。TI 提供这些资源并不会扩展或以其他方式更改 TI 针对 TI 产品发布的适用的担保或担保免责声明。除非德州仪器 (TI) 明确将某产品指定为定制产品或客户特定产品，否则其产品均为按确定价格收入目录的标准通用器件。

TI 反对并拒绝您可能提出的任何其他或不同的条款。

版权所有 © 2026，德州仪器 (TI) 公司

最后更新日期：2025 年 10 月