

# TPS40197 4.5V 至 14V 输入、6A 降压控制器 具有 4 位 VID 接口

## 1 特性

- 输入电压范围：4.5V 至 14V
- 4 位动态 VID 即时转换支持
- 具有可编程转换率的 VID 可编程输出电压
- 520kHz 固定开关频率
- 可选的低侧（三个设置）和固定高侧热补偿过流保护
- 电源正常指示器
- 内部 5V 稳压器
- 电压模式控制
- 内部固定 5.5ms 软启动时间
- 预偏置输出安全保护
- 140°C 时进行热关断
- 16 引脚 QFN 封装

## 2 应用

- Smart-Reflex™ DSP
- POL 模块
- 电信

## 3 说明

TPS40197 是一款同步降压控制器，可在 4.5V 至 14V 的标称输入电源电压下工作。该控制器采用电压模式控制架构，具有 520kHz 的固定开关频率。由于更高的开关频率有利于使用较小的电感器和输出电容器，因此可实现紧凑型电源解决方案。自适应反交叉传导方案可用于避免功率 FET 出现直通电流。

TPS40197 在单芯片中集成了 PWM 控制和 4 位 VID 接口，可使用可编程的转换率实现无缝即时 VID 切换。它为 Smart-Reflex™ DSP 内核提供了一个简单的电源解决方案。

### 器件信息(1)

器件型号	封装	封装尺寸（标称值）
TPS40197	VQFN (16)	4.50mm x 3.50mm

(1) 如需了解所有可用封装，请参阅数据表末尾的可订购产品附录。

典型应用电路

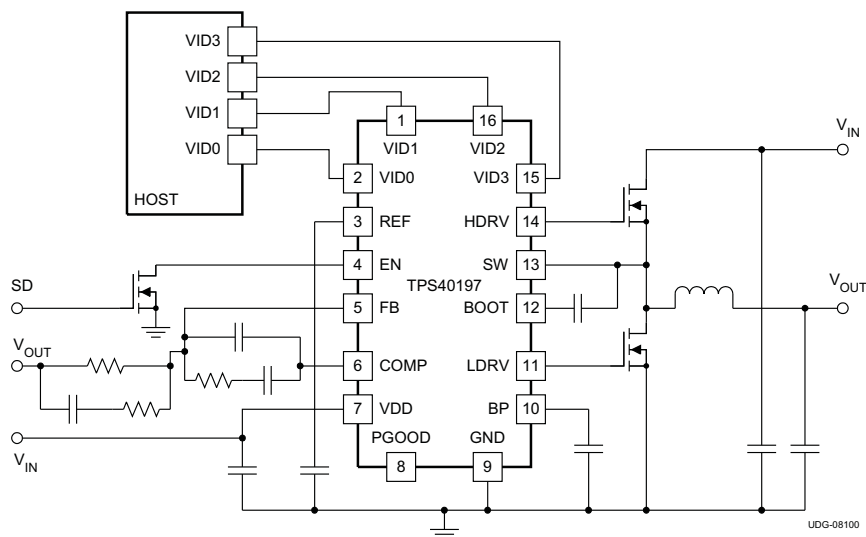

## 目录

<b>1</b>	特性 .....	<b>1</b>	<b>8.1</b>	Overview .....	<b>12</b>
<b>2</b>	应用 .....	<b>1</b>	<b>8.2</b>	Functional Block Diagram .....	<b>12</b>
<b>3</b>	说明 .....	<b>1</b>	<b>8.3</b>	Feature Description .....	<b>13</b>
<b>4</b>	修订历史记录 .....	<b>2</b>	<b>9</b>	<b>Application and Implementation</b> .....	<b>19</b>
<b>5</b>	说明 (续) .....	<b>3</b>	<b>9.1</b>	Application Information .....	<b>19</b>
<b>6</b>	<b>Pin Configuration and Functions</b> .....	<b>4</b>	<b>9.2</b>	Typical Application .....	<b>19</b>
<b>7</b>	<b>Specifications</b> .....	<b>5</b>	<b>10</b>	<b>器件和文档支持</b> .....	<b>21</b>
	7.1 Absolute Maximum Ratings .....	<b>5</b>	<b>10.1</b>	器件支持 .....	<b>21</b>
	7.2 ESD Ratings .....	<b>5</b>	<b>10.2</b>	文档支持 .....	<b>21</b>
	7.3 Recommended Operating Conditions .....	<b>5</b>	<b>10.3</b>	接收文档更新通知 .....	<b>21</b>
	7.4 Package Dissipation Ratings .....	<b>5</b>	<b>10.4</b>	社区资源 .....	<b>21</b>
	7.5 Electrical Characteristics .....	<b>6</b>	<b>10.5</b>	商标 .....	<b>21</b>
	7.6 Typical Characteristics .....	<b>8</b>	<b>10.6</b>	静电放电警告 .....	<b>21</b>
<b>8</b>	<b>Detailed Description</b> .....	<b>12</b>	<b>10.7</b>	Glossary .....	<b>22</b>
			<b>11</b>	<b>机械、封装和可订购信息</b> .....	<b>22</b>

## 4 修订历史记录

注：之前版本的页码可能与当前版本有所不同。

<b>Changes from Revision A (July 2012) to Revision B</b>	<b>Page</b>
• 仅有编辑更改；无技术性修订 .....	<b>1</b>

  

<b>Changes from Original (November 2008) to Revision A</b>	<b>Page</b>
• Added a new paragraph to the Enable section .....	<b>13</b>

## 5 说明（续）

短路检测是通过检测低侧 FET（通电时）上的压降并将其与用户选择的 100mV、200mV 或 280mV 阈值进行比较而实现的。此阈值可通过从 COMP 连接到 GND 的单个外部电阻器进行设置。在启动时即对该电阻器进行检测并锁存所选阈值。通过检测高侧 FET（通电时）上的电压并在压降上升超过 550mV 固定阈值时终止周期来提供逐脉冲限流功能（以防止电流失控）。如果控制器检测到输出短路，则会关闭两个 FET，并在达到超时时间后尝试重启。这能在持续故障情况下实现有限的功率耗散。

## 6 Pin Configuration and Functions

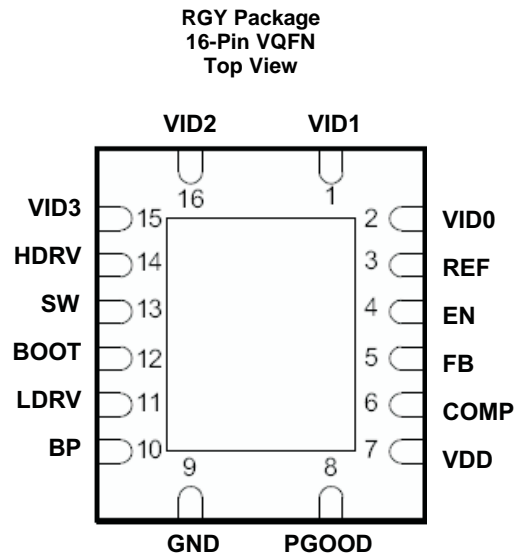

### Pin Functions

PIN		I/O	DESCRIPTION
NAME	NO.		
BOOT	12	I	Gate drive voltage for the high-side N-channel MOSFET. A 100-nF capacitor (typical) must be connected between this pin and SW.
BP	10	O	Output bypass for the internal regulator. Connect a low ESR bypass ceramic capacitor of 1 $\mu$ F or greater from this pin to GND.
COMP	6	O	Output of the error amplifier and connection node for loop feedback components.
EN	4	I	Logic level input which starts or stops the controller from an external user command. A high level turns the controller on. A weak internal pullup holds this pin high so that the pin may be left floating if this function is not used. Pulling this pin low disables the controller.
FB	5	I	Inverting input to the error amplifier.
HDRV	14	O	Bootstrapped gate drive output for the high-side N-channel MOSFET.
LDRV	11	O	Gate drive output for the low-side synchronous rectifier N-channel MOSFET.
PGOOD	8	O	Open drain power good output.
REF	3	I	Non-Inverting input to the error amplifier. Its voltage range is from 0.9 V to 1.2 V in 20-mV steps. It is also internally connected to the DAC output through a unit gain buffer with 650- $\mu$ A source/sink current capability. An external capacitor connected from this pin to GND programs the output voltage transition rate when VID code changes.
VDD	7	I	Power input to the controller. Connect a 1- $\mu$ F bypass capacitor closely from this pin to GND.
VID0	2	I	Logic level inputs to the internal DAC that provides the reference voltage for output regulation. These pins are internally pulled up to a 1.68-V source with 80- $\mu$ A pullup current.
VID1	1	I	
VID2	16	I	
VID3	15	I	
GND	9		Ground connection to the controller

## 7 Specifications

### 7.1 Absolute Maximum Ratings<sup>(1)</sup>

over operating free-air temperature range (unless otherwise noted)

		VALUE	UNIT
Input voltage	VDD, EN	–0.3 to 20	V
	SW	–5 to 25	
	BOOT, HDRV	–0.3 to 30	
	BOOT–SW, HDRV–SW	–0.3 to 6	
	FB, BP, LDRV, PGOOD, REF	–0.3 to 6	
Output voltage	COMP	–0.3 to 3.5	V
	VID0, VID1, VID2, VID3	–0.3 to 2	
Operating junction temperature range, T <sub>J</sub>		–40 to 150	°C
Storage temperature, T <sub>stg</sub>		–55 to 150	°C

- (1) Stresses beyond those listed under *absolute maximum ratings* may cause permanent damage to the device. These are stress ratings only and functional operation of the device at these or any other conditions beyond those indicated under *recommended operating conditions* is not implied. Exposure to absolute-maximum-rated conditions for extended periods may affect device reliability.

### 7.2 ESD Ratings

			VALUE	UNIT
V <sub>(ESD)</sub>	Electrostatic discharge	Human-body model (HBM), per ANSI/ESDA/JEDEC JS-001 <sup>(1)</sup>	2500	V
		Charged-device model (CDM), per JEDEC specification JESD22-C101 <sup>(2)</sup>	1500	

- (1) JEDEC document JEP155 states that 500-V HBM allows safe manufacturing with a standard ESD control process.  
(2) JEDEC document JEP157 states that 250-V CDM allows safe manufacturing with a standard ESD control process.

### 7.3 Recommended Operating Conditions

over operating free-air temperature range (unless otherwise noted)

		MIN	MAX	UNIT
Supply voltage	VDD	4.5	14	V
Operating junction temperature, T <sub>J</sub>		–40	125	°C

### 7.4 Package Dissipation Ratings

PACKAGE	AIRFLOW (LFM)	R <sub>θJA</sub> HIGH-K Board <sup>(1)</sup> (°C/W)	POWER RATING (W) T <sub>A</sub> = 25°C	POWER RATING (W) T <sub>A</sub> = 85°C
16-Pin Plastic Quad Flatpack (RGY)	0 (Natural Convection)	49.2	2.0	0.81
	200	41.2	2.4	0.97
	400	37.7	2.6	1.00

- (1) Ratings based on JEDEC High Thermal Conductivity (High K) Board. For more information on the test method, see TI Technical Brief SZZA017.

## 7.5 Electrical Characteristics

–40°C ≤ T<sub>J</sub> ≤ 85°C, V<sub>VDD</sub> = 12 V, all parameters at zero power dissipation (unless otherwise noted)

PARAMETER		TEST CONDITIONS	MIN	TYP	MAX	UNIT
<b>VOLTAGE REFERENCE AND VID</b>						
V <sub>FB</sub>	FB input voltage	0.9 V ≤ V <sub>VID</sub> ≤ 1.2 V, 0°C ≤ T <sub>J</sub> ≤ 85°C	–0.5%		0.5%	V <sub>VID</sub>
		0.9 V ≤ V <sub>VID</sub> ≤ 1.2 V, –40°C ≤ T <sub>J</sub> ≤ 85°C	–1.0%		1.0%	
I <sub>VID</sub>	VID pullup current		50	80	120	μA
V <sub>VID</sub>	VID pullup voltage		1.60	1.68	1.78	V
t <sub>ANTI-SKEW (1)</sub>	Anti-skew filtering time		300	550	750	ns
V <sub>VIDH</sub>	VID high-level input voltage		0.8	1.0	1.3	V
V <sub>VIDL</sub>	VID low-level input voltage		0.30	0.55	0.70	V
I <sub>REF</sub>	REF source/sink current		400	650	850	μA
<b>INPUT SUPPLY</b>						
V <sub>VDD</sub>	Normal input supply voltage range		4.5		14.0	V
I <sub>VDD</sub>	Operating current	V <sub>ENABLE</sub> = 3 V		2.5	4.5	mA
		V <sub>ENABLE</sub> = 0.6 V		45	70	μA
<b>SOFT START</b>						
t <sub>SS</sub>	Soft-start time		3.3	5.5	7	ms
t <sub>SSDLY</sub>	Soft-start delay time		1.3	2.3	4	
t <sub>REG</sub>	Time to regulation		5.0	8.0	11	
<b>ON-BOARD REGULATOR</b>						
V <sub>BP</sub>	Output voltage	V <sub>VDD</sub> > 6 V, I <sub>BP</sub> ≤ 10 mA	5.1	5.3	5.5	V
V <sub>DO</sub>	Regulator dropout voltage (V <sub>VDD</sub> –V <sub>BP</sub> )	V <sub>VDD</sub> > 5 V, I <sub>BP</sub> ≤ 25 mA		350	550	mV
I <sub>SC</sub>	Regulator current limit threshold		50			mA
I <sub>BP</sub>	Average current				50	
<b>OSCILLATOR</b>						
f <sub>SW</sub>	Switching frequency		420	520	600	kHz
V <sub>RAMP (1)</sub>	Ramp amplitude			1		V
<b>PWM</b>						
D <sub>MAX (1)</sub>	Maximum duty cycle		85%			
t <sub>ON(min) (1)</sub>	Minimum controllable pulse				110	ns
t <sub>DEAD</sub>	Output driver dead time	HDRV off to LDRV on		50		
		LDRV off to HDRV on		25		
<b>ERROR AMPLIFIER</b>						
G <sub>BWP (1)</sub>	Gain bandwidth product		7	10		MHz
A <sub>OL (1)</sub>	Open loop gain		60			dB
I <sub>IB</sub>	Input bias current (current out of FB pin)				100	nA
I <sub>EAOP</sub>	Output source current	V <sub>FB</sub> = 0 V	1			mA
I <sub>EAOM</sub>	Output sink current	V <sub>FB</sub> = 2 V	1			
<b>UNDERVOLTAGE LOCKOUT</b>						
V <sub>UVLO</sub>	Turn-on voltage		3.9	4.2	4.4	V
UVLO <sub>HYST</sub>	Hysteresis		700	850	1000	mV
<b>SHUTDOWN</b>						
V <sub>IH</sub>	High-level input voltage, ENABLE			1.9	3	V
V <sub>IL</sub>	Low-level input voltage, ENABLE		0.6	1.2		

(1) Specified by design. Not production tested.

**Electrical Characteristics (continued)**
 $-40^{\circ}\text{C} \leq T_J \leq 85^{\circ}\text{C}$ ,  $V_{\text{VDD}} = 12\text{ V}$ , all parameters at zero power dissipation (unless otherwise noted)

PARAMETER		TEST CONDITIONS	MIN	TYP	MAX	UNIT
<b>OUTPUT DRIVERS</b>						
$R_{\text{HDHI}}$	High-side driver pull-up resistance	$(V_{\text{BOOT}} - V_{\text{SW}}) - 4.5\text{ V}$ , $I_{\text{HDR V}} = -100\text{ mA}$		3	6	$\Omega$
$R_{\text{HDLO}}$	High-side driver pull-down resistance	$(V_{\text{BOOT}} - V_{\text{SW}}) - 4.5\text{ V}$ , $I_{\text{HDR V}} = 100\text{ mA}$		1.5	3	
$R_{\text{LDHI}}$	Low-side driver pull-up resistance	$I_{\text{LDRV}} = -100\text{ mA}$		2.5	5	
$R_{\text{LDLO}}$	Low-side driver pull-down resistance	$I_{\text{LDRV}} = 100\text{ mA}$		0.8	1.5	
$t_{\text{HRISE}}^{(1)}$	High-side driver rise time	$C_{\text{LOAD}} = 1\text{ nF}$		15	35	ns
$t_{\text{HFALL}}^{(1)}$	High-side driver fall time			10	25	
$t_{\text{LRISE}}^{(1)}$	Low-side driver rise time			15	35	
$t_{\text{LFALL}}^{(1)}$	Low-side driver fall time			10	25	
<b>SHORT CIRCUIT PROTECTION</b>						
$t_{\text{PSS(min)}}^{(1)}$	Minimum pulse time during short circuit			250		ns
$t_{\text{BLNK}}^{(1)}$	Switch leading-edge blanking pulse time		60	90	120	
$t_{\text{OFF}}$	Off-time between restart attempts		30	50		ms
$V_{\text{ILIM}}$	Short circuit comparator threshold voltage	$R_{\text{COMP(GND)}} = \text{OPEN}$ , $T_J = 25^{\circ}\text{C}$	160	200	240	mV
		$R_{\text{COMP(GND)}} = 4\text{ k}\Omega$ , $T_J = 25^{\circ}\text{C}$	80	100	120	
		$R_{\text{COMP(GND)}} = 12\text{ k}\Omega$ , $T_J = 25^{\circ}\text{C}$	228	280	342	
$V_{\text{ILIMH}}$	Short circuit threshold voltage on high-side MOSFET	$T_J = 25^{\circ}\text{C}$	400	550	650	
<b>POWER GOOD</b>						
$V_{\text{OV}}$	Feedback voltage limit for powergood		106%	110%	114%	VID
$V_{\text{UV}}$			86%	90%	94%	
$V_{\text{PG\_HYST}}$	Powergood hysteresis voltage at FB pin		10	30	70	mV
$R_{\text{PGD}}$	Pull-down resistance of PGD pin	$V_{\text{FB}} < 90\% V_{\text{VID}}$ mV or $V_{\text{FB}} > 110\% V_{\text{VID}}$		7	50	$\Omega$
$I_{\text{PDGLK}}$	Leakage current	$90\% V_{\text{VID}} \leq V_{\text{FB}} \leq 100\% V_{\text{VID}}$ , $V_{\text{PGOOD}} = 5\text{ V}$		7	12	$\mu\text{A}$
<b>BOOT DIODE</b>						
$V_{\text{DFWD}}$		$I_{\text{BOOT}} = 5\text{ mA}$	0.5	0.8	1.2	V
<b>THERMAL SHUTDOWN</b>						
$T_{\text{JSD}}^{(1)}$	Junction shutdown temperature			140		$^{\circ}\text{C}$
$T_{\text{JSDH}}^{(1)}$	Hysteresis			20		

## 7.6 Typical Characteristics

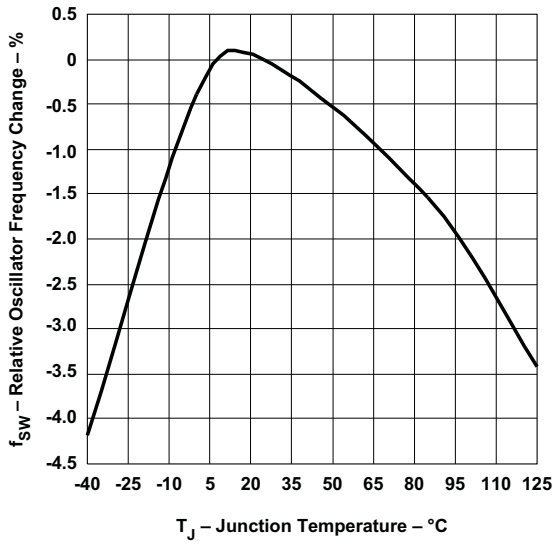

Figure 1. Relative Oscillator Frequency vs Junction Temperature

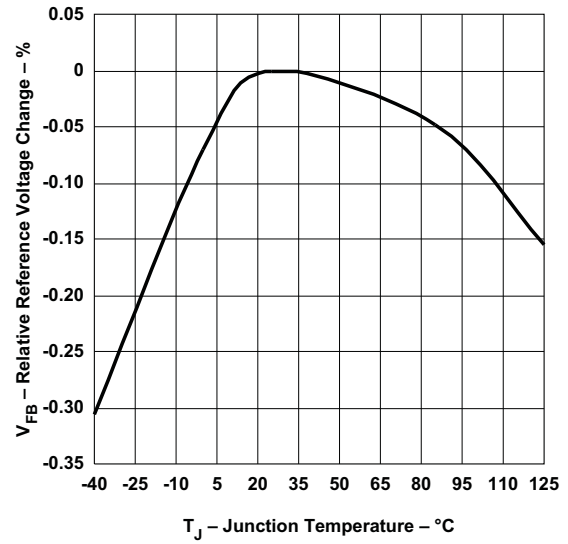

Figure 2. Relative Reference Voltage Change vs Junction Temperature

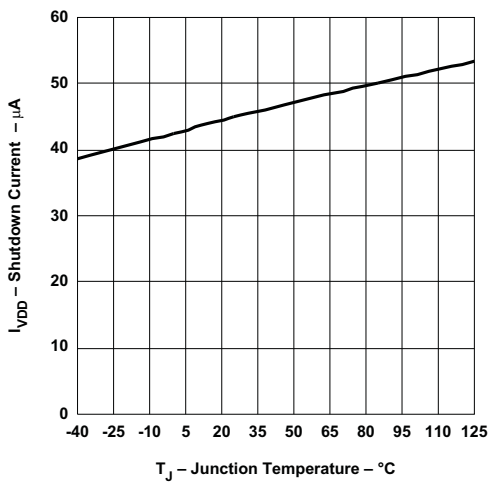

Figure 3. Shutdown Current vs Junction Temperature

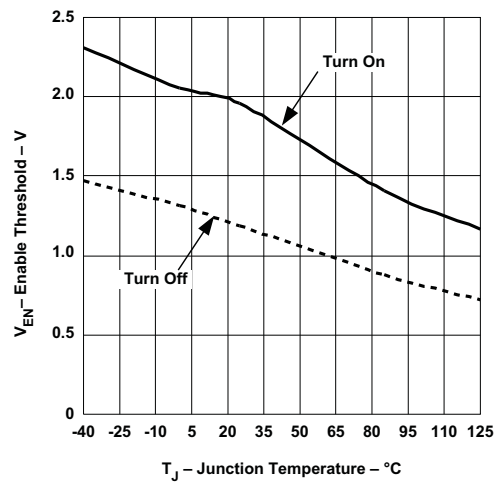

Figure 4. Enable Threshold vs Junction Temperature

Typical Characteristics (continued)

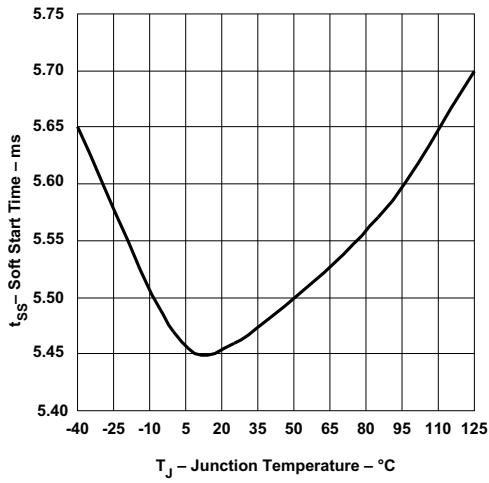

Figure 5. Soft-Start Time vs Junction Temperature

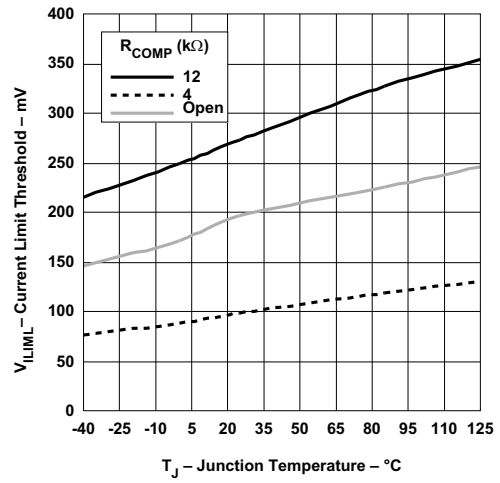

Figure 6. Low-Side MOSFET Current Limit Threshold vs Junction Temperature

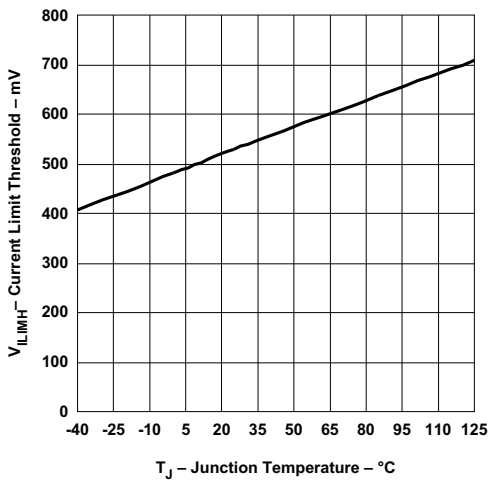

Figure 7. High-Side MOSFET Current Limit Threshold vs Junction Temperature

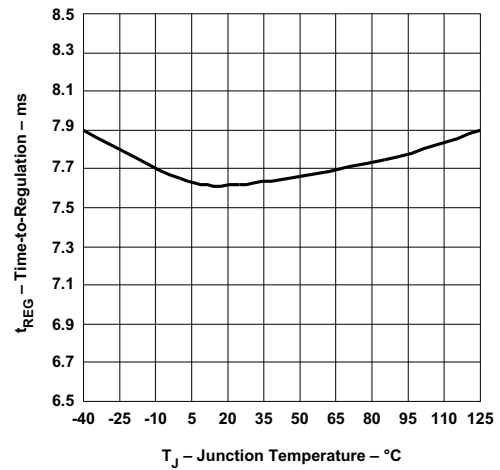

Figure 8. Total Time-To-Regulation vs Junction Temperature

Typical Characteristics (continued)

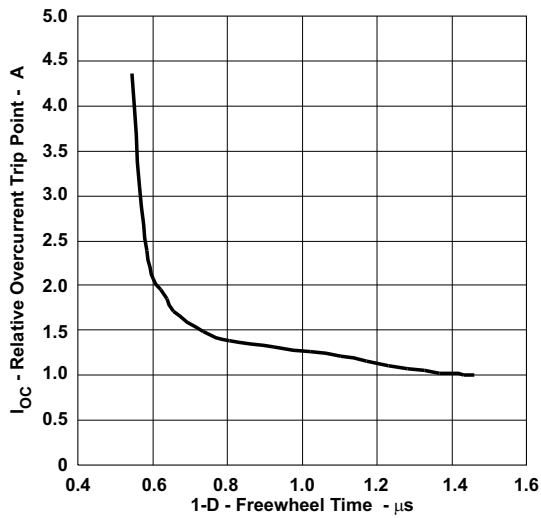

Figure 9. Relative Overcurrent Trip Point vs Freewheel Time

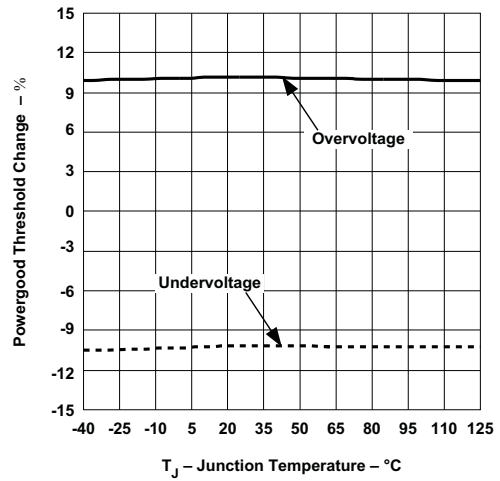

Figure 10. Relative Power Good Threshold vs Junction Temperature

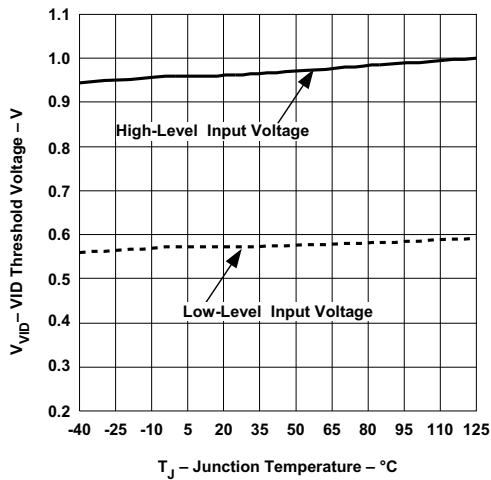

Figure 11. VID Threshold Voltage vs Junction Temperature

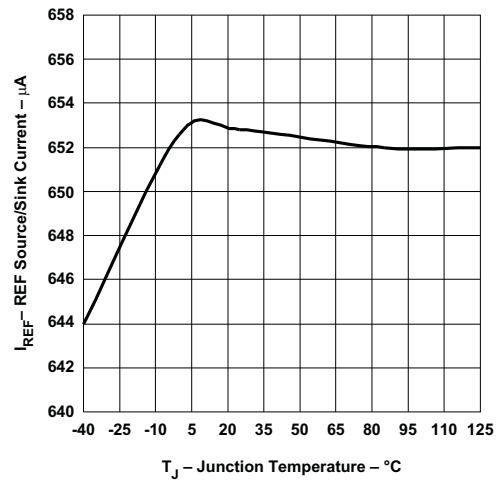

Figure 12. REF Source/Sink Current vs Junction Temperature

Typical Characteristics (continued)

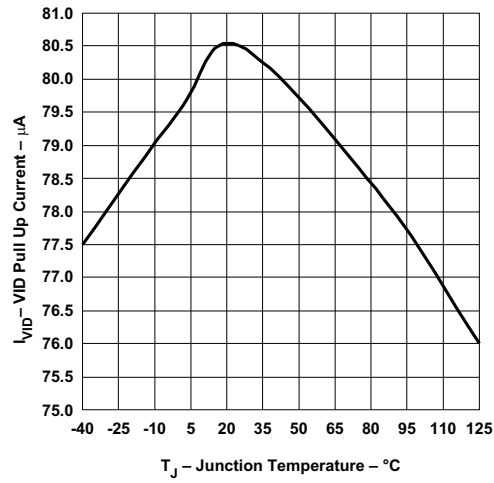

Figure 13. VID Pullup Current vs Junction Temperature

## 8 Detailed Description

### 8.1 Overview

The TPS40197 is a synchronous buck controller which provides all the necessary features to construct a high-performance DC/DC converter. Support for pre-biased outputs eliminates concerns about damaging sensitive loads during startup. Strong gate drivers for the high-side and rectifier MOSFETs decrease switching losses for increased efficiency. Adaptive gate drive timing prevents shoot through and minimizes body diode conduction in the rectifier MOSFET, also increasing efficiency. Selectable short-circuit protection thresholds and hiccup recovery from a short-circuit increase design flexibility and minimize power dissipation in the event of a prolonged output fault. A dedicated enable pin allows the converter to be placed in a very low quiescent current shutdown mode. Internally fixed switching frequency and soft-start time reduce external component count, simplifying design and layout, as well as reducing footprint and cost. The dynamic voltage identification (VID) circuitry is designed to provide Smart-Reflex™ power supply solution to DSPs with core voltage optimization.

### 8.2 Functional Block Diagram

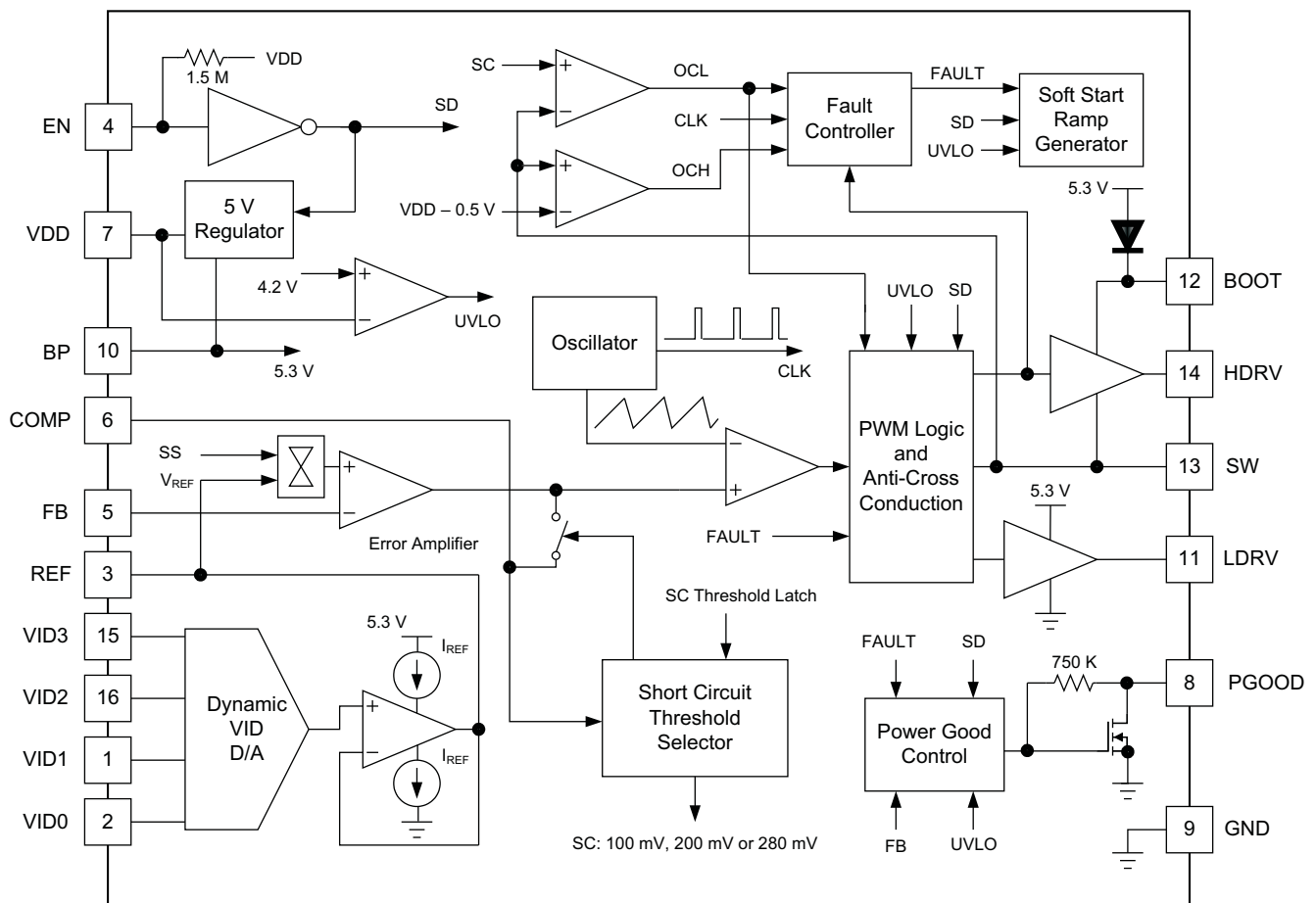

## 8.3 Feature Description

### 8.3.1 Enable

The TPS40197 includes a dedicated EN pin. This simplifies user level interface design since no multiplexed functions exist. Another benefit is a true low-power shutdown mode of operation. When the EN pin is pulled to GND, all unnecessary functions, including the BP regulator, are turned off, reducing the  $I_{VDD}$  current to 45  $\mu\text{A}$ . A functionally equivalent circuit of the enable circuitry is shown in Figure 14.

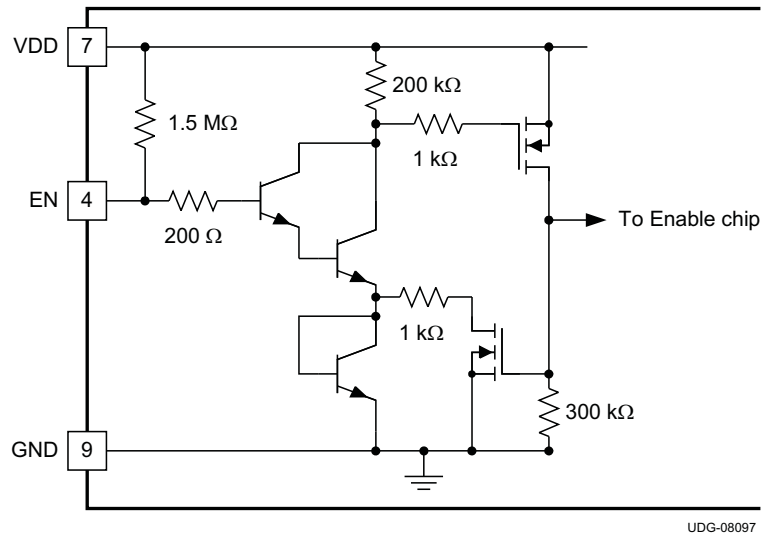

Figure 14. Tps40197 En Pin Internal Circuitry

If the EN pin is left floating, the device starts automatically. The pin must be pulled to less than 600 mV to specify that the TPS40197 is in shutdown mode. Note that the EN pin is relatively high impedance. In some situations, there could be enough noise nearby to cause the EN pin to swing below the 600-mV threshold and give erroneous shutdown commands to other components of the device. There are two solutions to this potential problem.

- Place a capacitor from EN to GND. A side-effect of this is to delay the start of the converter while the capacitor charges past the enable threshold.
- Place a resistor from VDD to EN. This causes more current to flow in the shutdown mode, but does not delay converter start-up. If a resistor is used, the total current into the EN pin must be limited to no more than 500  $\mu\text{A}$ .

The ENABLE pin is self clamping. The clamp voltage can be as low as 1 V with a 1-k $\Omega$  ground impedance. Due to this self-clamping feature, the pull-up impedance on the ENABLE pin should be selected to limit the sink current to less than 500  $\mu\text{A}$ . Driving the ENABLE pin with a low-impedance source voltage can result in damage to the device. Because of the self-clamping feature, it requires care when connecting multiple ENABLE pins together. For enabling multiple TPS4019x devices (TPS40190, TPS40192, TPS40193, TPS40195, TPS40197), see application report [SLVA509](#).

### 8.3.2 Oscillator

The fixed internal switching frequency of the TPS40197 is 520 kHz.

### 8.3.3 UVLO

When the input voltage is below the UVLO threshold, the device holds all gate drive outputs in the low (OFF) state. When the input rises above the UVLO threshold, and the EN pin is above the turn ON threshold, the oscillator begins to operate and the start-up sequence is allowed to begin. The UVLO level is internally fixed at 4.2 V.

## Feature Description (continued)

### 8.3.4 Start-up Sequence and Timing

The TPS40197 startup sequence is as follows. After input power is applied, the 5-V onboard regulator initiates. Once this regulator comes up, the device goes through a period where it samples the impedance at the COMP pin and determines the short-circuit protection threshold voltage, by placing 400 mV on the COMP pin for approximately 1.15 ms. During this time, the current is measured and compared against internal thresholds to select the short circuit protection threshold. After this, the COMP pin is brought low for 1.15 ms. This ensures that the feedback loop is preconditioned at startup and no sudden output rise occurs at the output of the converter when the converter is allowed to start switching. After these initial 2.3 ms, the internal soft-start circuitry is engaged and the converter is allowed to start as shown in [Figure 15](#).

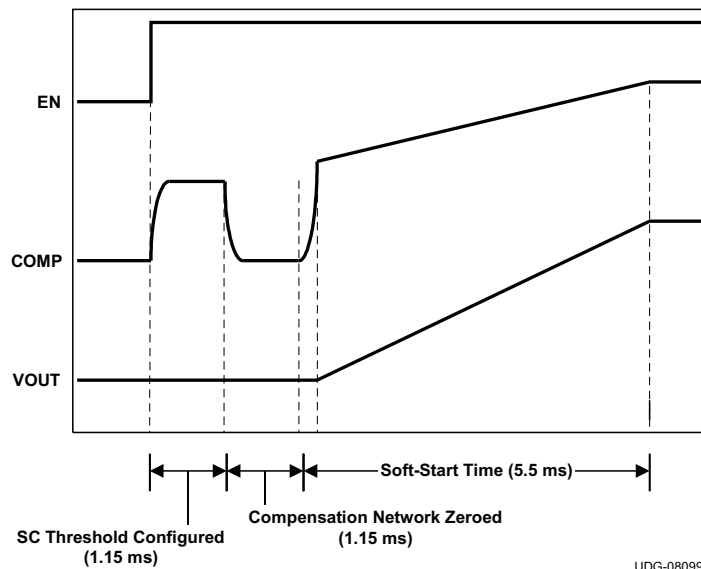

**Figure 15. Start-up Sequence**

### 8.3.5 Selecting the Short Circuit Current

A short circuit in the TPS40197 is detected by sensing the voltage drop across the low-side FET when it is on, and across the high-side FET when it is on. If the voltage drop across either FET exceeds the short-circuit threshold in any given switching cycle, a counter increments one count. If the voltage across the high-side FET was higher than the short circuit threshold, that FET is turned off early. If the voltage drop across either FET does not exceed the short circuit threshold during a cycle, the counter is decremented for that cycle. If the counter fills up (a count of 7) a fault condition is declared and the drivers turn off both MOSFETs. After a timeout of approximately 50 ms, the controller attempts to restart. If a short circuit continues at the output, the current quickly ramps up to the short-circuit threshold and another fault condition is declared and the process of waiting for the 50 ms and attempting to restart repeats. The low-side threshold increases as the low-side on time decreases due to blanking time and comparator response time. See [Figure 9](#) for changes in the threshold as the low-side FET conduction time decreases.

The TPS40197 provides three selectable short-circuit protection thresholds for the low-side FET: 100 mV, 200 mV, and 280 mV. The particular threshold is selected by connecting a resistor from COMP to GND. [Table 1](#) shows the short-circuit thresholds for corresponding resistors from COMP to GND. When designing the compensation for the feedback loop, remember that a low impedance compensation network combined with a long network time constant can cause the short-circuit threshold setting to not be as expected. The time constant and impedance of the network connected from COMP to FB must be as in [Equation 1](#) to ensure no interaction with the short-circuit threshold setting.

Feature Description (continued)

$$\left(\frac{0.4\text{ V}}{R1}\right) \times e^{\left(\frac{-t}{R1 \times C1}\right)} \leq 10\ \mu\text{A}$$

where

- t is 1.15 ms, the sampling time of the short circuit threshold setting circuit
  - R1 and C1 are the values of the components in Figure 16
- (1)

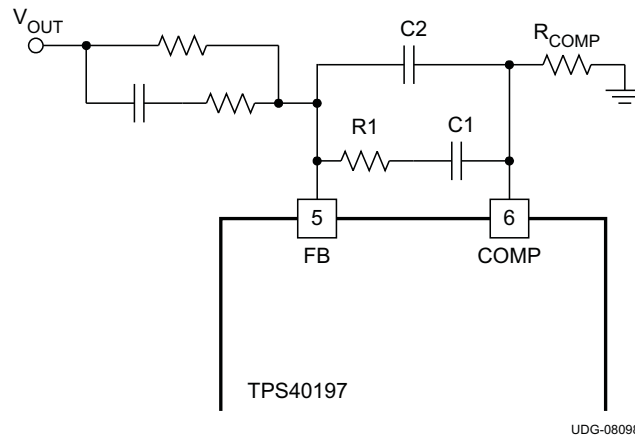

Figure 16. Short Circuit Threshold Feedback Network

Table 1. Circuit Threshold Voltage Selection

COMPARATOR RESISTANCE R <sub>COMP</sub> (kΩ)	CURRENT LIMIT THRESHOLD VOLTAGE V <sub>ILIM</sub> (mV)
12 ±10%	280
OPEN	200
4 ±10%	100

The range of expected short-circuit current thresholds is shown in Equation 2 and Equation 3.

$$I_{SCP(max)} = \frac{V_{ILIM(max)}}{R_{DS(on)min}}$$

(2)

$$I_{SCP(min)} = \frac{V_{ILIM(min)}}{R_{DS(on)max}}$$

where

- I<sub>SCP</sub> is the short circuit current
  - V<sub>ILIM</sub> is the short-circuit threshold for the low-side MOSFET
  - R<sub>DS(on)</sub> is the channel resistance of the low-side MOSFET
- (3)

Note that due to blanking time considerations, overcurrent threshold accuracy may fall off for duty cycle greater than 75% because the overcurrent comparator has only a very short time to sample the SW pin voltage under these conditions and may not have time to respond to voltages very near the threshold.

The short-circuit protection threshold for the high-side MOSFET is fixed at 550 mV typical, 400 mV minimum. This threshold is in place to provide a maximum current output using pulse-by-pulse current limit in the case of a fault. The pulse terminates when the voltage drop across the high-side FET exceeds the short-circuit threshold. The maximum amount of current that can be specified to be sourced from a converter can be found by [Equation 4](#).

$$I_{OUT(max)} = \frac{V_{ILIMH(min)}}{R_{DS(on)max}}$$

where

- $I_{OUT(max)}$  is the maximum current that the converter is specified to source
  - $V_{ILIMH(min)}$  is the short-circuit threshold for the high-side MOSFET (400 mV)
  - $R_{DS(on)max}$  is the maximum resistance of the high-side MOSFET
- (4)

If the required current from the converter is greater than the calculated  $I_{OUT(max)}$ , a lower resistance high-side MOSFET must be chosen. Both the high-side and low-side thresholds use temperature compensation to approximate the change in resistance for a typical power MOSFET. This helps counteract shifts in overcurrent thresholds as temperature increases. For this to be effective, the MOSFETs and the device must be well coupled thermally.

### 8.3.6 Voltage Reference and Dynamic VID

To provide optimized voltage for Smart-Reflex™ DSP cores, the TPS40197 is designed to monitor the VID code at all times once soft-start is complete, and actively adjusts its output voltage if the VID code should change during normal operation. A digital-to-analog converter (DAC) generates a reference voltage based on the state of logical signals at pins VID0 through VID3. The DAC decodes the 4-bit logic signal into one of the discrete voltages shown in [Table 2](#). The default setting for the output is 1.2 V (VID code 1111). The output voltage is 1.2 V during initial start or restart after cycling the input, toggling EN pin or recovering from a short circuit at the output.

To ensure that no erroneous output voltage is produced, the TPS40197 VID inputs have internal anti-skew circuit with approximately 550 ns of filtering time. Each VID input is pulled up to an internal 1.68-V source with 80-μA pullup current for use with open-drain outputs.

The output voltage can be programmed from 0.9 V to 1.2 V in 20 mV steps. Smooth upward and downward core voltage transition can be achieved by programming the transition rate with an external capacitor connected from REF pin to GND. The required capacitance can be calculated using [Equation 5](#).

$$C_{REF} = \frac{(I_{REF} \times T_{TR})}{V_{VID-TR}}$$

where

- $V_{VID-TR}$  is the total voltage transition through VID
  - $I_{REF}$  is the internal reference source/sink current
  - $T_{TR}$  is the intended total VID voltage transition time
- (5)

$C_{REF}$  must be limited to a maximum of 1.5 μF to avoid interfering with the soft start. A capacitor ( $C_{REF}$ ) with a minimum capacitance of 100-nF is also recommended.

**Table 2. Voltage Identification Codes**

VID TERMINALS (0 = LOW, 1 = HIGH)				V <sub>REF</sub>
VID3	VID2	VID1	VID0	(Vdc)
0	0	0	0	0.90
0	0	0	1	0.92
0	0	1	0	0.94
0	0	1	1	0.96
0	1	0	0	0.98
0	1	0	1	1.00
0	1	1	0	1.02
0	1	1	1	1.04
1	0	0	0	1.06
1	0	0	1	1.08
1	0	1	0	1.10
1	0	1	1	1.12
1	1	0	0	1.14
1	1	0	1	1.16
1	1	1	0	1.18
1	1	1	1	1.20

### 8.3.7 Minimum On-Time Consideration

The TPS40197 has a minimum on-time of 110 ns (maximum). With the restriction of this minimum on-time, the device may begin to skip pulses to effectively lower the overall on-time to keep the output in regulation when operating at high input-to-output conversion ratio. If pulse skipping is undesirable for some reason, it is recommended that the maximum input voltage be limited to 13.5 V.

### 8.3.8 BP Regulator

The TPS40197 has an on board 5-V BP regulator that allows the parts to operate from a single voltage feed. No separate 5-V feed to the part is required. This regulator needs to have a minimum of 1- $\mu$ F of capacitance on the BP pin for stability. A ceramic capacitor is suggested for this purpose.

This regulator can also be used to supply power to nearby circuitry, eliminating the need for a separate LDO in some cases. If this pin is used for external loads, be aware that this is the power supply for the internals of the TPS40197. While efforts have been made to reduce sensitivity, any noise induced on this line has an adverse effect on the overall performance of the internal circuitry and shows up as increased pulse jitter, or skewed reference voltage. Also, when the device is disabled by pulling the EN pin low, this regulator is turned off and will not be available to supply power.

The amount of power available from this pin varies with the size of the power MOSFETs that the drivers must operate. Larger MOSFETs require more gate drive current and reduce the amount of power available on this pin for other tasks. The total current that can be drawn from this pin by both the gate drive and external loads cannot exceed 50 mA. The device itself consumes up to 4 mA from the regulator and the total gate drive current can be found from [Equation 6](#).

### 8.3.9 Prebias Start-up

The TPS40197 contains a unique circuit to prevent current from being pulled from the output during startup in the condition the output is prebiased. When the soft start commands a voltage higher than the pre-bias level (internal soft-start becomes greater than feedback voltage [V<sub>FB</sub>]), the controller slowly activates synchronous rectification by starting the first LDRV pulse with a narrow on-time. It then increments that on-time on a cycle-by-cycle basis until it coincides with the time dictated by (1-D), where D is the duty cycle of the converter. This scheme prevents the initial sinking of the pre-bias output, and ensures that the output voltage (V<sub>OUT</sub>) starts and ramps up smoothly into regulation and the control loop is given time to transition from pre-biased start-up to normal mode operation with minimal disturbance to the output voltage. The amount of time from the start of switching until the low-side MOSFET is turned on for the full (1-D) interval is defined by 32 clock cycles.

### 8.3.10 Drivers

The drivers for the external HDRV and LDRV MOSFETs are capable of driving a gate-to-source voltage of 5 V. The LDRV driver switches between BP and GND, while HDRV driver is referenced to SW and switches between BOOT and SW. The drivers have non-overlapping timing that is governed by an adaptive delay circuit to minimize body diode conduction in the synchronous rectifier. The drivers are capable of driving MOSFETS that are appropriate for a 15-A converter.

### 8.3.11 Power Good

The TPS40197 provides an indication that output power is good for the converter. This is an open drain signal and pulls low when any condition exists that would indicate that the output of the supply might be out of regulation. These conditions include:

- $V_{FB}$  is more than 10% from the reference voltage based on VID codes
- soft-start is active
- an undervoltage condition exists for the device
- a short-circuit condition has been detected
- die temperature is over (140°C)

---

#### NOTE

When there is no power to the device, PGOOD is not able to pull close to GND if an auxiliary supply is used for the power good indication. In this case, a built in resistor connected from drain to gate on the PGOOD pull down device makes the PGOOD pin look approximately like a diode to GND.

---

### 8.3.12 Thermal Shutdown

If the junction temperature of the device reaches the thermal shutdown limit of 140°C, the PWM and the oscillator are turned off and HDRV and LDRV are driven low, turning off both FETs. When the junction cools to the required level (120°C nominal), the PWM initiates soft-start as during a normal power-up cycle.

## 9 Application and Implementation

### NOTE

Information in the following applications sections is not part of the TI component specification, and TI does not warrant its accuracy or completeness. TI's customers are responsible for determining suitability of components for their purposes. Customers should validate and test their design implementation to confirm system functionality.

### 9.1 Application Information

The TPS40197 is a synchronous buck controller that operates from 4.5-V to 14-V input supply nominally. The controller implements voltage-mode control architecture with the switching frequency fixed at 520 kHz. The higher switching frequency facilitates the use of smaller inductor and output capacitors, thereby providing a compact power-supply solution.

### 9.2 Typical Application

The schematic for the design is shown in [Figure 17](#) and the list of materials is shown in [Table 3](#).

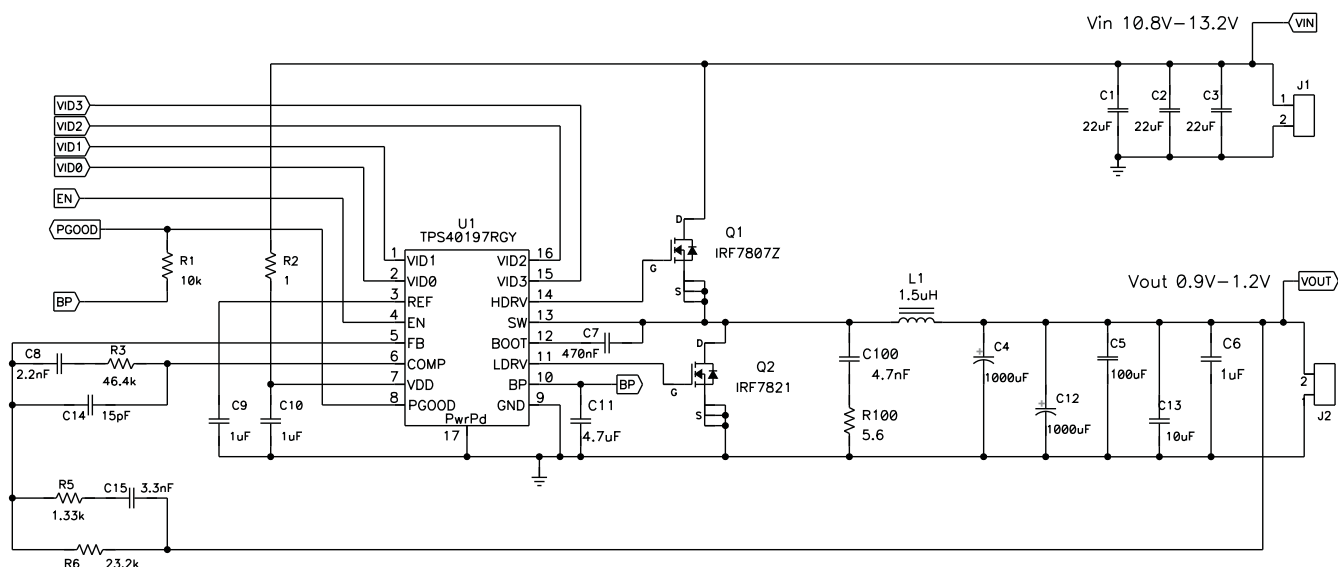

**Figure 17. TPS40197 Sample Schematic**

## Typical Application (continued)

### 9.2.1 Design Requirements

**Table 3. Design Example List Of Materials**

REFERENCE DESIGNATOR	QTY	DESCRIPTION	MFR	PART NUMBER
C1, C2, C3	3	Capacitor, ceramic, 16 V, X7R, 20%, 22 $\mu$ F, 1210	TDK	C3225X7R1C226K
C4, C12	2	Capacitor, POSCAP, 2.5 V, 20%, 1 mF, 5 m $\Omega$ , D4D	Sanyo	2R5TPD1000M5
C5	1	Capacitor, ceramic, 6.3 V, X5R, 20%, 100 $\mu$ F, 1210	TDK	C3225X5R0J107K
C6, C9, C10	3	Capacitor, ceramic, 16 V, X7R, 20%, 1 $\mu$ F, 0603	Std	Std
C7	1	Capacitor, ceramic, 10 V, X5R, 20%, 470 nF, 0603	Std	Std
C8	1	Capacitor, ceramic, 50 V, NPO, 10%, 2.2 nF, 0603	Std	Std
C11	1	Capacitor, ceramic, 6.3 V, X5R, 20%, 4.7 $\mu$ F, 0603	TDK	C1608X5R0J475K
C13	1	Capacitor, ceramic, 6.3 V, X5R, 20%, 10 $\mu$ F, 0603	TDK	C1608X5R0J106K
C14	1	Capacitor, ceramic, 50 V, NPO, 10%, 15 pF, 0603	Std	Std
C15	1	Capacitor, ceramic, 50 V, X7R, 20%, 3.3 nF, 0603	Std	Std
C100	1	Capacitor, ceramic, 50 V, X7R, 20%, 4.7 nF, 0603	Std	Std
L1	1	Inductor, SMT, 27 A, 1.5 $\mu$ H, 2.5 m $\Omega$ , 0.508 x 0.520	Vishay	IHLP5050FDER1R5M01
Q1	1	MOSFET, N-channel, 30 V, 11A, 13.8 m $\Omega$ , SO-8	IR	IRF7807Z
Q2	1	MOSFET, N-channel, 30 V, 13.6 A, 9.1 m $\Omega$ , SO-8	IR	IRF7821
R1	1	Resistor, chip, 1/16 W, 5%, 10 k $\Omega$ , 0603	Std	Std
R2	1	Resistor, chip, 1/16 W, 5%, 1 $\Omega$ , 0603	Std	Std
R3	1	Resistor, chip, 1/16 W, 1%, 46.4 k $\Omega$ , 0603	Std	Std
R5	1	Resistor, chip, 1/16 W, 1%, 1.33 k $\Omega$ , 0603	Std	Std
R6	1	Resistor, chip, 1/16 W, 1%, 23.2 k $\Omega$ , 0603	Std	Std
R100	1	Resistor, chip, 1/4 W, 5%, 5.6 $\Omega$ , 1206	Std	Std
U1	1	IC, synchronous buck controller with 4-bit VID interface for Smart-Reflex DSPs, QFN-16	TI	TPS40197RGY

### 9.2.2 Detailed Design Procedure

For regulator stability, a 1- $\mu$ F capacitor is required to be connected from BP to GND. In some applications using higher gate charge MOSFETs, a larger capacitor is required for noise suppression. For a total gate charge of both the high-side and low-side MOSFETs greater than 20 nC, a 2.2- $\mu$ F or larger capacitor is recommended.

$$I_G = f_{SW} \times (Q_{G(\text{high})} + Q_{G(\text{low})})$$

where

- $I_G$  is the required gate drive current
  - $f_{SW}$  is the switching frequency
  - $Q_{G(\text{high})}$  is the gate charge requirement for the high-side FET when  $V_{GS} = 5$  V
  - $Q_{G(\text{low})}$  is the gate charge requirement for the low-side FET when  $V_{GS} = 5$  V
- (6)

## 10 器件和文档支持

### 10.1 器件支持

#### 10.1.1 第三方产品免责声明

TI 发布的与第三方产品或服务有关的信息，不能构成与此类产品或服务或保修的适用性有关的认可，不能构成此类产品或服务单独或与任何 TI 产品或服务一起的表示或认可。

### 10.2 文档支持

#### 10.2.1 相关器件

以下器件具有与 TPS40197 相似的特性，您可能对此感兴趣。

TI 文献编号	器件	说明
SLUS719	TPS40192	具有电源正常指示器的 4.5V 至 18V 输入同步降压控制器
	TPS40193	

#### 10.2.2 相关文档

TI 文献编号	文档类型	说明
SPRAAW7	应用报告	TMS320C6474 硬件设计指南
SLVA057	应用报告	了解开关模式电源中的降压功率级
SLUP206	研讨会系列	《低电压直流/直流转换器内幕揭秘》，SEM-1500，2003 年
SLUP173	研讨会系列	《设计稳定控制环路》，SEM-1400，2001 年
SLMA002	应用报告	PowerPAD™热增强型封装
SLMA004	应用报告	《PowerPAD™速成》

### 10.3 接收文档更新通知

要接收文档更新通知，请导航至 [TI.com.cn](http://TI.com.cn) 上的器件产品文件夹。单击右上角的 **通知我** 进行注册，即可每周接收产品信息更改摘要。有关更改的详细信息，请查看任何已修订文档中包含的修订历史记录。

### 10.4 社区资源

The following links connect to TI community resources. Linked contents are provided "AS IS" by the respective contributors. They do not constitute TI specifications and do not necessarily reflect TI's views; see TI's [Terms of Use](#).

**TI E2E™ Online Community** *TI's Engineer-to-Engineer (E2E) Community*. Created to foster collaboration among engineers. At [e2e.ti.com](http://e2e.ti.com), you can ask questions, share knowledge, explore ideas and help solve problems with fellow engineers.

**Design Support** *TI's Design Support* Quickly find helpful E2E forums along with design support tools and contact information for technical support.

### 10.5 商标

Smart-Reflex, PowerPAD, E2E are trademarks of Texas Instruments.

### 10.6 静电放电警告



ESD 可能会损坏该集成电路。德州仪器 (TI) 建议通过适当的预防措施处理所有集成电路。如果不遵守正确的处理措施和安装程序，可能会损坏集成电路。

ESD 的损坏小至导致微小的性能降级，大至整个器件故障。精密的集成电路可能更容易受到损坏，这是因为非常细微的参数更改都可能会导致器件与其发布的规格不相符。

## 10.7 Glossary

[SLYZ022](#) — *TI Glossary*.

This glossary lists and explains terms, acronyms, and definitions.

## 11 机械、封装和可订购信息

以下页面包含机械、封装和可订购信息。这些信息是指定器件的最新可用数据。数据如有变更，恕不另行通知，且不会对此文档进行修订。如需获取此数据表的浏览器版本，请查阅左侧的导航栏。

**PACKAGING INFORMATION**

Orderable part number	Status (1)	Material type (2)	Package   Pins	Package qty   Carrier	RoHS (3)	Lead finish/ Ball material (4)	MSL rating/ Peak reflow (5)	Op temp (°C)	Part marking (6)
<a href="#">TPS40197RGYR</a>	Active	Production	VQFN (RGY)   16	3000   LARGE T&R	Yes	NIPDAU	Level-2-260C-1 YEAR	-40 to 85	40197
TPS40197RGYR.A	Active	Production	VQFN (RGY)   16	3000   LARGE T&R	Yes	NIPDAU	Level-2-260C-1 YEAR	-40 to 85	40197
<a href="#">TPS40197RGYT</a>	Active	Production	VQFN (RGY)   16	250   SMALL T&R	Yes	NIPDAU	Level-2-260C-1 YEAR	-40 to 85	40197
TPS40197RGYT.A	Active	Production	VQFN (RGY)   16	250   SMALL T&R	Yes	NIPDAU	Level-2-260C-1 YEAR	-40 to 85	40197

(1) **Status:** For more details on status, see our [product life cycle](#).

(2) **Material type:** When designated, preproduction parts are prototypes/experimental devices, and are not yet approved or released for full production. Testing and final process, including without limitation quality assurance, reliability performance testing, and/or process qualification, may not yet be complete, and this item is subject to further changes or possible discontinuation. If available for ordering, purchases will be subject to an additional waiver at checkout, and are intended for early internal evaluation purposes only. These items are sold without warranties of any kind.

(3) **RoHS values:** Yes, No, RoHS Exempt. See the [TI RoHS Statement](#) for additional information and value definition.

(4) **Lead finish/Ball material:** Parts may have multiple material finish options. Finish options are separated by a vertical ruled line. Lead finish/Ball material values may wrap to two lines if the finish value exceeds the maximum column width.

(5) **MSL rating/Peak reflow:** The moisture sensitivity level ratings and peak solder (reflow) temperatures. In the event that a part has multiple moisture sensitivity ratings, only the lowest level per JEDEC standards is shown. Refer to the shipping label for the actual reflow temperature that will be used to mount the part to the printed circuit board.

(6) **Part marking:** There may be an additional marking, which relates to the logo, the lot trace code information, or the environmental category of the part.

Multiple part markings will be inside parentheses. Only one part marking contained in parentheses and separated by a "~" will appear on a part. If a line is indented then it is a continuation of the previous line and the two combined represent the entire part marking for that device.

**Important Information and Disclaimer:** The information provided on this page represents TI's knowledge and belief as of the date that it is provided. TI bases its knowledge and belief on information provided by third parties, and makes no representation or warranty as to the accuracy of such information. Efforts are underway to better integrate information from third parties. TI has taken and continues to take reasonable steps to provide representative and accurate information but may not have conducted destructive testing or chemical analysis on incoming materials and chemicals. TI and TI suppliers consider certain information to be proprietary, and thus CAS numbers and other limited information may not be available for release.

In no event shall TI's liability arising out of such information exceed the total purchase price of the TI part(s) at issue in this document sold by TI to Customer on an annual basis.

**TAPE AND REEL INFORMATION**

**QUADRANT ASSIGNMENTS FOR PIN 1 ORIENTATION IN TAPE**

\*All dimensions are nominal

Device	Package Type	Package Drawing	Pins	SPQ	Reel Diameter (mm)	Reel Width W1 (mm)	A0 (mm)	B0 (mm)	K0 (mm)	P1 (mm)	W (mm)	Pin1 Quadrant
TPS40197RGYR	VQFN	RGY	16	3000	330.0	12.4	3.71	4.21	1.11	8.0	12.0	Q1
TPS40197RGYR	VQFN	RGY	16	3000	330.0	12.4	3.8	4.3	1.5	8.0	12.0	Q1
TPS40197RGYT	VQFN	RGY	16	250	180.0	12.4	3.8	4.3	1.5	8.0	12.0	Q1
TPS40197RGYT	VQFN	RGY	16	250	180.0	12.5	3.71	4.21	1.11	8.0	12.0	Q1

**TAPE AND REEL BOX DIMENSIONS**

\*All dimensions are nominal

Device	Package Type	Package Drawing	Pins	SPQ	Length (mm)	Width (mm)	Height (mm)
TPS40197RGYR	VQFN	RGY	16	3000	338.0	355.0	35.0
TPS40197RGYR	VQFN	RGY	16	3000	353.0	353.0	32.0
TPS40197RGYT	VQFN	RGY	16	250	213.0	191.0	35.0
TPS40197RGYT	VQFN	RGY	16	250	338.0	355.0	35.0

RGY (R-PVQFN-N16)

PLASTIC QUAD FLATPACK NO-LEAD

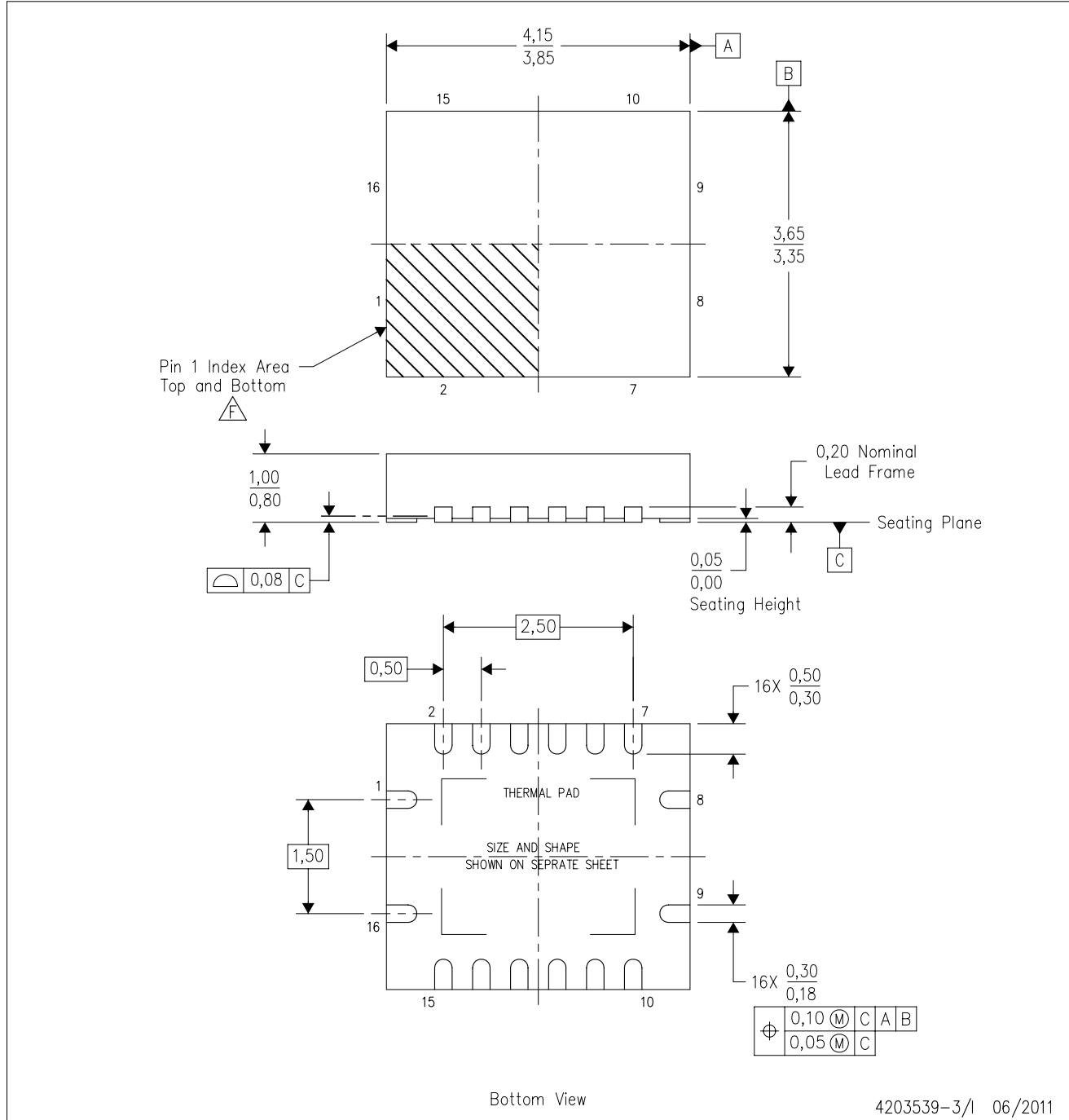

4203539-3/1 06/2011

- NOTES:
- All linear dimensions are in millimeters. Dimensioning and tolerancing per ASME Y14.5M-1994.
  - This drawing is subject to change without notice.
  - QFN (Quad Flatpack No-Lead) package configuration.
  - The package thermal pad must be soldered to the board for thermal and mechanical performance.
  - See the additional figure in the Product Data Sheet for details regarding the exposed thermal pad features and dimensions.
  - Pin 1 identifiers are located on both top and bottom of the package and within the zone indicated. The Pin 1 identifiers are either a molded, marked, or metal feature.
  - Package complies to JEDEC MO-241 variation BA.

RGY (R-PVQFN-N16)

PLASTIC QUAD FLATPACK NO-LEAD

**THERMAL INFORMATION**

This package incorporates an exposed thermal pad that is designed to be attached directly to an external heatsink. The thermal pad must be soldered directly to the printed circuit board (PCB). After soldering, the PCB can be used as a heatsink. In addition, through the use of thermal vias, the thermal pad can be attached directly to the appropriate copper plane shown in the electrical schematic for the device, or alternatively, can be attached to a special heatsink structure designed into the PCB. This design optimizes the heat transfer from the integrated circuit (IC).

For information on the Quad Flatpack No-Lead (QFN) package and its advantages, refer to Application Report, QFN/SON PCB Attachment, Texas Instruments Literature No. SLUA271. This document is available at [www.ti.com](http://www.ti.com).

The exposed thermal pad dimensions for this package are shown in the following illustration.



Bottom View

Exposed Thermal Pad Dimensions

4206353-3/P 03/14

NOTE: All linear dimensions are in millimeters

RGY (R-PVQFN-N16)

PLASTIC QUAD FLATPACK NO-LEAD



4208122-3/P 03/14

- NOTES:
- A. All linear dimensions are in millimeters.
  - B. This drawing is subject to change without notice.
  - C. Publication IPC-7351 is recommended for alternate designs.
  - D. This package is designed to be soldered to a thermal pad on the board. Refer to Application Note, Quad Flat-Pack QFN/SON PCB Attachment, Texas Instruments Literature No. SLUA271, and also the Product Data Sheets for specific thermal information, via requirements, and recommended board layout. These documents are available at [www.ti.com](http://www.ti.com) <<http://www.ti.com>>.
  - E. Laser cutting apertures with trapezoidal walls and also rounding corners will offer better paste release. Customers should contact their board assembly site for stencil design recommendations. Refer to IPC 7525 for stencil design considerations.
  - F. Customers should contact their board fabrication site for minimum solder mask web tolerances between signal pads.

## 重要通知和免责声明

TI“按原样”提供技术和可靠性数据（包括数据表）、设计资源（包括参考设计）、应用或其他设计建议、网络工具、安全信息和其他资源，不保证没有瑕疵且不做任何明示或暗示的担保，包括但不限于对适销性、与某特定用途的适用性或不侵犯任何第三方知识产权的暗示担保。

这些资源可供使用 TI 产品进行设计的熟练开发人员使用。您将自行承担以下全部责任：(1) 针对您的应用选择合适的 TI 产品，(2) 设计、验证并测试您的应用，(3) 确保您的应用满足相应标准以及任何其他安全、安保法规或其他要求。

这些资源如有变更，恕不另行通知。TI 授权您仅可将这些资源用于研发本资源所述的 TI 产品的相关应用。严禁以其他方式对这些资源进行复制或展示。您无权使用任何其他 TI 知识产权或任何第三方知识产权。对于因您对这些资源的使用而对 TI 及其代表造成的任何索赔、损害、成本、损失和债务，您将全额赔偿，TI 对此概不负责。

TI 提供的产品受 [TI 销售条款](#)、[TI 通用质量指南](#) 或 [ti.com](#) 上其他适用条款或 TI 产品随附的其他适用条款的约束。TI 提供这些资源并不会扩展或以其他方式更改 TI 针对 TI 产品发布的适用的担保或担保免责声明。除非德州仪器 (TI) 明确将某产品指定为定制产品或客户特定产品，否则其产品均为按确定价格收入目录的标准通用器件。

TI 反对并拒绝您可能提出的任何其他或不同的条款。

版权所有 © 2026，德州仪器 (TI) 公司

最后更新日期：2025 年 10 月