

具有 3.2A 开关的 TPS61087 650kHz、1.2MHz、18.5V 升压直流/直流转换器

1 特性

- 输入电压范围：2.5V 至 6V
- 具有 3.2A 开关电流的 18.5V 升压转换器
- 650kHz、1.2MHz 可选开关频率
- 可调节软启动
- 热关断
- 欠压锁定
- 10 引脚 QFN 和薄型 QFN 封装

2 应用

- 手持设备
- GPS 接收器
- 数码相机
- 便携式应用
- DSL 调制解调器
- PCMCIA 卡
- TFT LCD 偏置电源

3 说明

TPS61087 是一款高频、高效的直流/直流转换器，具有能够提供高达 18.5V 输出电压的集成 3.2A、0.13Ω 电源开关。650kHz 或 1.2MHz 的可选频率使得此器件能够使用小型外部电感器和电容器，并提供快速瞬态响应。利用外部补偿，可以针对具体条件优化应用。连接至软启动引脚的电容器可最大程度地降低启动时的浪涌电流。

器件信息(1)

器件型号	封装	封装尺寸 (标称值)
TPS61087	VSON (10)	3.00mm × 3.00mm
	WSON (10)	

(1) 如需了解所有可用封装，请参阅数据表末尾的可订购产品附录。

简化原理图

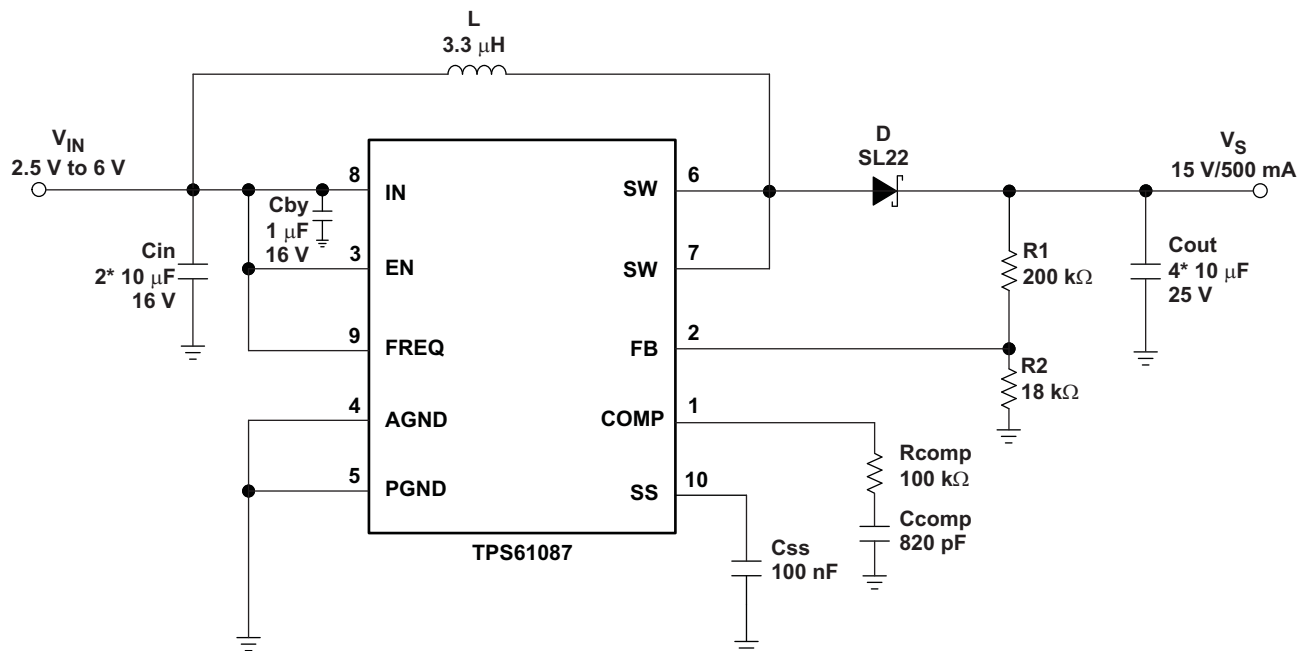

目录

1 特性	1	7.4 Device Functional Modes.....	10
2 应用	1	8 Application and Implementation	11
3 说明	1	8.1 Application Information.....	11
4 修订历史记录	2	8.2 Typical Application	11
5 Pin Configuration and Functions	4	8.3 System Examples	17
6 Specifications.....	4	9 Power Supply Recommendations.....	22
6.1 Absolute Maximum Ratings	4	10 Layout.....	22
6.2 ESD Ratings.....	5	10.1 Layout Guidelines	22
6.3 Recommended Operating Conditions.....	5	10.2 Layout Example	23
6.4 Thermal Information	5	11 器件和文档支持	24
6.5 Electrical Characteristics.....	5	11.1 第三方产品免责声明.....	24
6.6 Typical Characteristics.....	6	11.2 商标.....	24
7 Detailed Description	9	11.3 静电放电警告.....	24
7.1 Overview	9	11.4 Glossary	24
7.2 Functional Block Diagram	9	12 机械、封装和可订购信息.....	24
7.3 Feature Description.....	10		

4 修订历史记录

注：之前版本的页码可能与当前版本有所不同。

Changes from Revision D (August 2014) to Revision E	Page
• Changed device number from TPS61085 (typo) to TPS61087 (correct) in the Application Information description paragraph.	11
• Changed device number from TPS61085 (typo) to TPS61087 (correct) in the Power Supply Recommendations section.	22

Changes from Revision C (July 2013) to Revision D	Page
• 已添加 添加了 ESD 额定值表、特性说明部分、器件功能模式、应用和实施部分、电源相关建议部分、布局部分、器件和文档支持部分以及机械、封装和可订购信息部分	1

Changes from Revision B (March 2010) to Revision C	Page
• Added V_{IH} Test Condition for EN, $V_{IN} = 2.5\text{ V}$ to 4.3 V	6

Changes from Revision A (June 2008) to Revision B	Page
• Added DSC package to PIN ASSIGNMENT	4
• Deleted Lead temperature from Absolute Maximum Ratings.....	4
• Changed f_{osc} to f_s in Electrical Characteristics Boost Converter Oscillator Frequency	6
• Changed $FREQ = \text{high}$ to $FREQ = V_{IN}$ in Electrical Characteristics Boost Converter Oscillator Frequency	6
• Changed $FREQ = \text{low}$ to $FREQ = GND$ in Electrical Characteristics Boost Converter Oscillator Frequency	6
• Added Maximum load current vs. Input voltage graph.....	6
• Added Maximum load current vs. Input voltage graph.....	6
• Changed f to f_s and Frequency to Oscillator Frequency in Figure 6	7
• Changed f to f_s and Frequency to Oscillator Frequency in Figure 7	7
• Changed the text in the Detailed Description	9
• Changed "inductor current ripple is below 20%" to " inductor current ripple is below 35%"	13
• Added output capacitor calculation.....	15

Changes from Original (May 2008) to Revision A	Page
• Added text to the Detailed Description - following the Block Diagram	9

5 Pin Configuration and Functions

DRC (VSON), DSC (WSON) Package
 10 Pins, 3 mm × 3 mm × 1 mm
 Top View

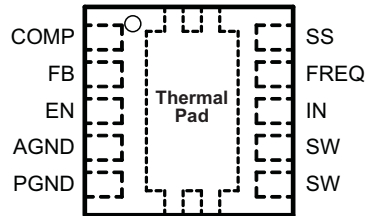

Pin Functions

PIN		I/O	DESCRIPTION
NAME	NO.		
AGND	4, Thermal Pad		Analog ground
COMP	1	I/O	Compensation pin
EN	3	I	Shutdown control input. Connect this pin to logic high level to enable the device
FB	2	I	Feedback pin
FREQ	9	I	Frequency select pin. The power switch operates at 650 kHz if FREQ is connected to GND and at 1.2 MHz if FREQ is connected to IN
IN	8	I	Input supply pin
PGND	5		Power ground
SS	10	O	Soft-start control pin. Connect a capacitor to this pin if soft-start needed. Open = no soft-start
SW	6, 7	I	Switch pin

6 Specifications

6.1 Absolute Maximum Ratings

over operating free-air temperature range (unless otherwise noted)⁽¹⁾

	MIN	MAX	UNIT
Input voltage range IN ⁽²⁾	-0.3	7.0	V
Voltage range on pins EN, FB, SS, FREQ, COMP	-0.3	7.0	V
Voltage on pin SW	-0.3	20	V
Continuous power dissipation	See Thermal Information		
Operating junction temperature range	-40	150	°C
Storage temperature range	-65	150	°C

- (1) Stresses beyond those listed under *Absolute Maximum Ratings* may cause permanent damage to the device. These are stress ratings only, and functional operation of the device at these or any other conditions beyond those indicated under *Recommended Operating Conditions* is not implied. Exposure to absolute-maximum-rated conditions for extended periods may affect device reliability
- (2) All voltage values are with respect to network ground terminal.

6.2 ESD Ratings

		VALUE	UNIT
$V_{(ESD)}$ Electrostatic discharge	Human body model (HBM), per ANSI/ESDA/JEDEC JS-001 ⁽¹⁾	±2000	V
	Charged-device model (CDM), per JEDEC specification JESD22-C101 ⁽²⁾	±500	
	Machine model (MM)	±200	

- (1) JEDEC document JEP155 states that 500-V HBM allows safe manufacturing with a standard ESD control process. Manufacturing with less than 500-V HBM is possible with the necessary precautions. Pins listed as ±2000 V may actually have higher performance.
- (2) JEDEC document JEP157 states that 250-V CDM allows safe manufacturing with a standard ESD control process. Manufacturing with less than 250-V CDM is possible with the necessary precautions. Pins listed as ±500 V may actually have higher performance.

6.3 Recommended Operating Conditions

		MIN	NOM	MAX	UNIT
V_{IN}	Input voltage range	2.5		6	V
V_S	Boost output voltage range	$V_{IN} + 0.5$		18.5	V
T_A	Operating free-air temperature	−40		85	°C
T_J	Operating junction temperature	−40		125	°C

6.4 Thermal Information

THERMAL METRIC ⁽¹⁾		TPS61087		UNIT
		DRC	DSC	
		10 PINS	10 PINS	
$R_{\theta JA}$	Junction-to-ambient thermal resistance	54.7	55.3	°C/W
$R_{\theta JC(top)}$	Junction-to-case (top) thermal resistance	67.2	84.8	°C/W
$R_{\theta JB}$	Junction-to-board thermal resistance	29.6	29.7	°C/W
Ψ_{JT}	Junction-to-top characterization parameter	2.3	5.4	°C/W
Ψ_{JB}	Junction-to-board characterization parameter	29.8	29.8	°C/W
$R_{\theta JC(bot)}$	Junction-to-case (bottom) thermal resistance	15.6	10.9	°C/W

- (1) For more information about traditional and new thermal metrics, see the *IC Package Thermal Metrics* application report, [SPRA953](#).

6.5 Electrical Characteristics

$V_{IN} = 5\text{ V}$, $EN = V_{IN}$, $V_S = 15\text{ V}$, $T_A = -40^\circ\text{C}$ to 85°C , typical values are at $T_A = 25^\circ\text{C}$ (unless otherwise noted)

PARAMETER		TEST CONDITIONS	MIN	TYP	MAX	UNIT
SUPPLY						
V_{IN}	Input voltage range		2.5		6	V
I_Q	Operating quiescent current into IN	Device not switching, $V_{FB} = 1.3\text{ V}$		75	100	μA
I_{SDVIN}	Shutdown current into IN	EN = GND			1	μA
V_{UVLO}	Undervoltage lockout threshold	V_{IN} falling			2.4	V
		V_{IN} rising			2.5	V
T_{SD}	Thermal shutdown	Temperature rising		150		°C
T_{SDHYS}	Thermal shutdown hysteresis			14		°C

Electrical Characteristics (continued)

 $V_{IN} = 5\text{ V}$, $EN = V_{IN}$, $V_S = 15\text{ V}$, $T_A = -40^\circ\text{C}$ to 85°C , typical values are at $T_A = 25^\circ\text{C}$ (unless otherwise noted)

PARAMETER		TEST CONDITIONS	MIN	TYP	MAX	UNIT
LOGIC SIGNALS EN, FREQ						
V_{IH}	High-level input voltage	$V_{IN} = 2.5\text{ V to }6.0\text{ V}$	2			V
		Valid only for EN, $V_{IN} = 2.5\text{ V to }4.3\text{ V}$	1.6			
V_{IL}	Low-level input voltage	$V_{IN} = 2.5\text{ V to }6.0\text{ V}$	0.5			V
I_{INLEAK}	Input leakage current	EN = FREQ = GND	0.1			μA
BOOST CONVERTER						
V_S	Boost output voltage		$V_{IN} + 0.5$	18.5		V
V_{FB}	Feedback regulation voltage		1.230	1.238	1.246	V
gm	Transconductance error amplifier		107			$\mu\text{A/V}$
I_{FB}	Feedback input bias current	$V_{FB} = 1.238\text{ V}$	0.1			μA
$r_{DS(on)}$	N-channel MOSFET on-resistance	$V_{IN} = V_{GS} = 5\text{ V}$, $I_{SW} = \text{current limit}$	0.13		0.18	Ω
		$V_{IN} = V_{GS} = 3\text{ V}$, $I_{SW} = \text{current limit}$	0.16		0.23	
I_{SWLEAK}	SW leakage current	EN = GND, $V_{SW} = V_{IN} = 6.0\text{ V}$	2			μA
I_{LIM}	N-Channel MOSFET current limit		3.2	4.0	4.8	A
I_{SS}	Soft-start current	$V_{SS} = 1.238\text{ V}$	7	10	13	μA
f_S	Oscillator frequency	FREQ = V_{IN}	0.9	1.2	1.5	MHz
		FREQ = GND	480	650	820	kHz
	Line regulation	$V_{IN} = 2.5\text{ V to }6.0\text{ V}$, $I_{OUT} = 10\text{ mA}$	0.0002			%/V
	Load regulation	$V_{IN} = 5.0\text{ V}$, $I_{OUT} = 1\text{ mA to }1\text{ A}$	0.11			%/A

6.6 Typical Characteristics

The typical characteristics are measured with the inductors 7447789003 3.3 μH (high frequency) or 74454068 6.8 μH (low frequency) from Würth and the rectifier diode SL22.

Table 1. Table of Graphs

			FIGURE
$I_{OUT(max)}$	Maximum load current	vs. Input voltage at High frequency (1.2 MHz)	Figure 1
$I_{OUT(max)}$	Maximum load current	vs. Input voltage at Low frequency (650 kHz)	Figure 2
η	Efficiency	vs. Load current, $V_S = 15\text{ V}$, $V_{IN} = 5\text{ V}$	Figure 3
η	Efficiency	vs. Load current, $V_S = 9\text{ V}$, $V_{IN} = 3.3\text{ V}$	Figure 4
	Supply current	vs. Supply voltage	Figure 5
	Oscillator frequency	vs. Load current	Figure 6
	Oscillator frequency	vs. Supply voltage	Figure 7

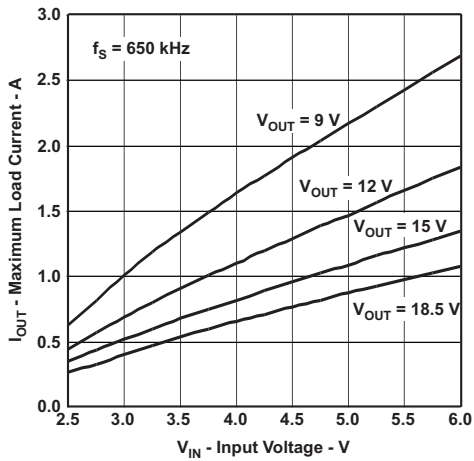

Figure 1. Maximum Load Current vs Input Voltage

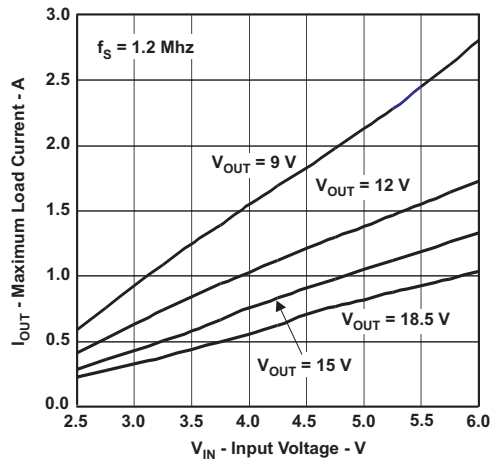

Figure 2. Maximum Load Current vs Input Voltage

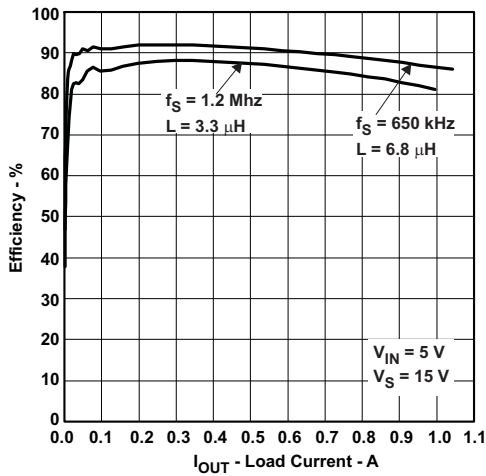

Figure 3. Efficiency vs Load Current

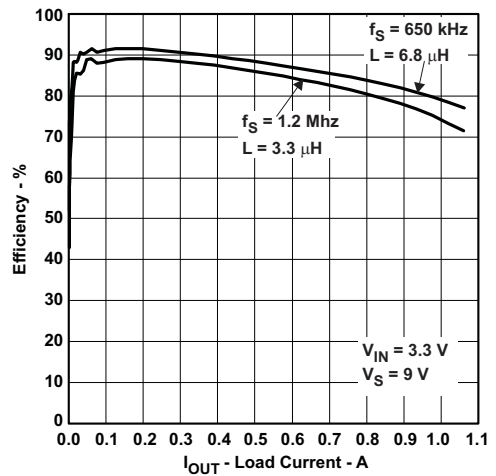

Figure 4. Efficiency vs Load Current

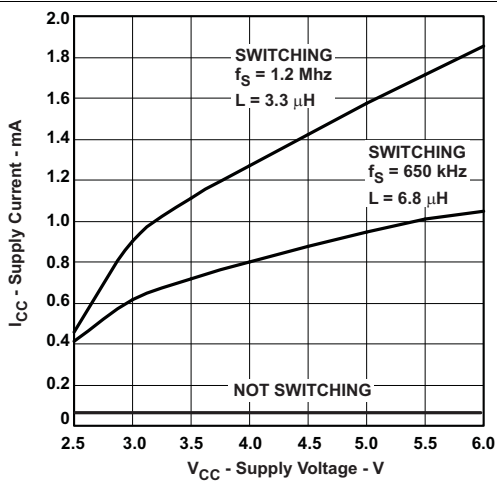

Figure 5. Supply Current vs Supply Voltage

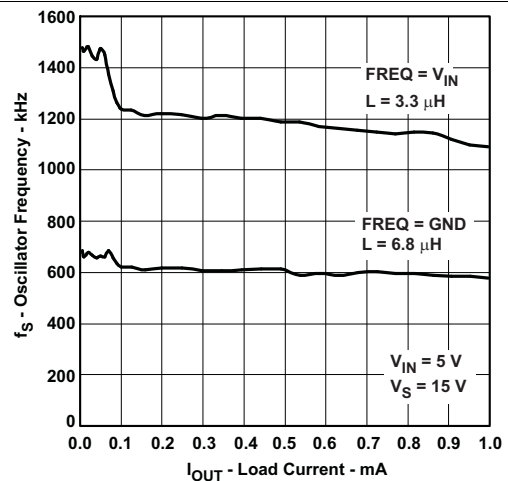

Figure 6. Oscillator Frequency vs Load Current

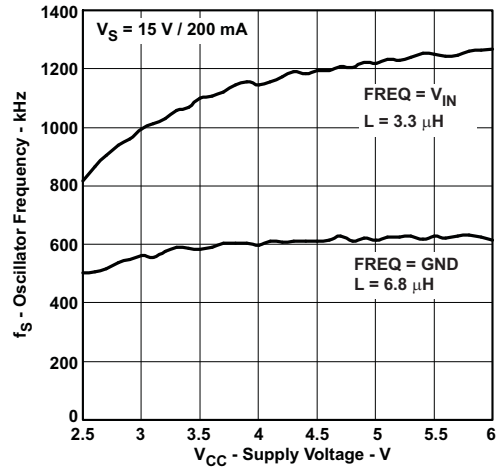

Figure 7. Oscillator Frequency vs Supply Voltage

7 Detailed Description

7.1 Overview

The boost converter is designed for output voltages of up to 18.5 V with a switch peak current limit of 3.2 A minimum. The device, which operates in a current mode scheme with quasi-constant frequency, is externally compensated for maximum flexibility and stability. The switching frequency is selectable between 650 kHz and 1.2 MHz, and the minimum input voltage is 2.5 V. To limit the inrush current at start-up, a soft-start pin is available.

The novel topology of the TPS60187 boost converter uses adaptive off-time to provide superior load and line transient responses. This topology also operates over a wider range of applications than conventional converters.

The selectable switching frequency offers the possibility to optimize the design either for the use of small-sized components (1.2 MHz) or for higher system efficiency (650 kHz). However, the frequency changes slightly because the voltage drop across the $r_{DS(on)}$ has some influence on the current and voltage measurement and thus on the on-time (the off-time remains constant).

The converter operates in continuous conduction mode (CCM) as soon as the input current increases above half the ripple current in the inductor, for lower load currents it switches into discontinuous conduction mode (DCM). If the load is further reduced, the part starts to skip pulses to maintain the output voltage.

7.2 Functional Block Diagram

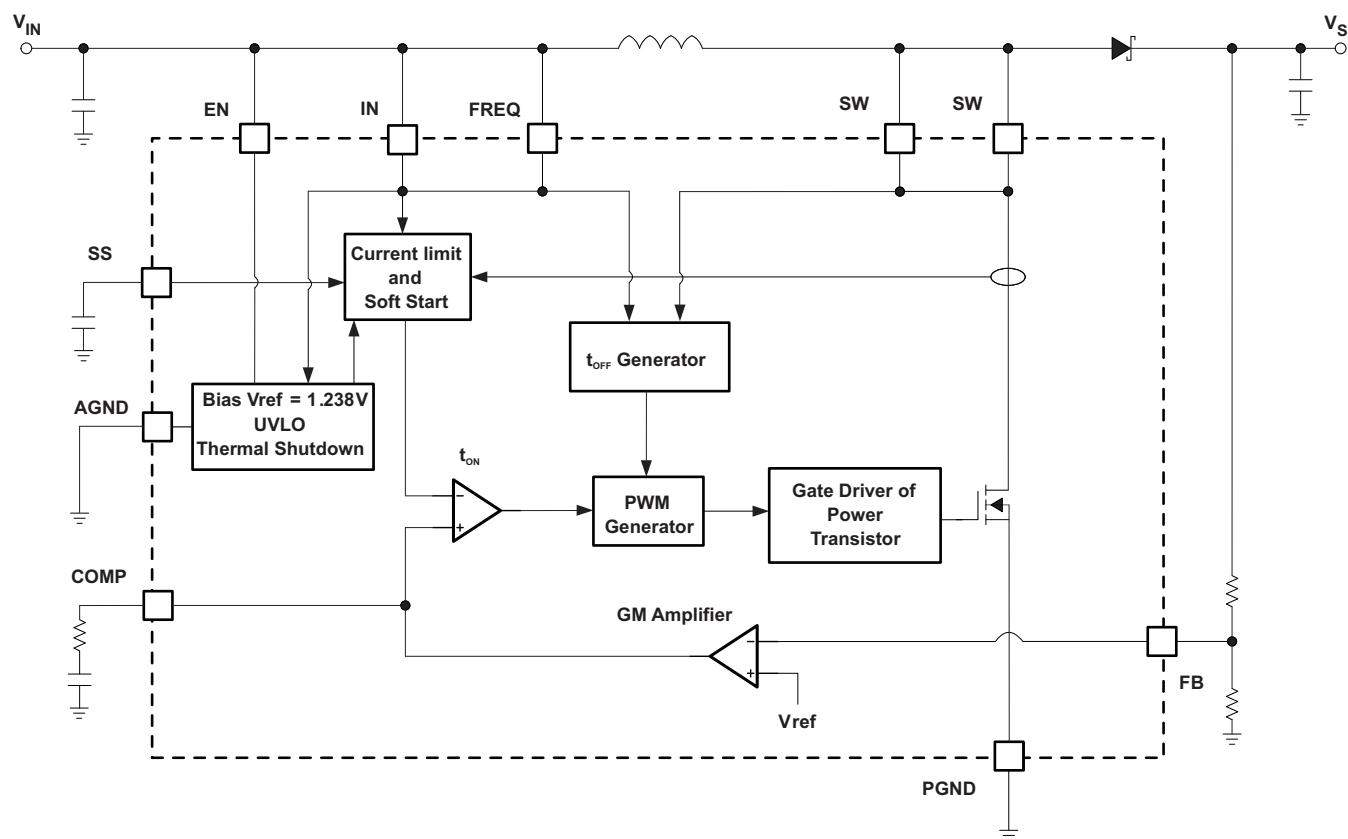

7.3 Feature Description

7.3.1 Soft-Start

The boost converter has an adjustable soft-start to prevent high inrush current during start-up. To minimize the inrush current during start-up an external capacitor, connected to the soft-start pin SS and charged with a constant current, is used to slowly ramp up the internal current limit of the boost converter. When the EN pin is pulled high, the soft-start capacitor C_{SS} is immediately charged to 0.3 V. The capacitor is then charged at a constant current of 10 μ A typically until the output of the boost converter V_S has reached its Power Good threshold (roughly 98% of V_S nominal value). During this time, the SS voltage directly controls the peak inductor current, starting with 0 A at $V_{SS} = 0.3$ V up to the full current limit at $V_{SS} = 800$ mV. The maximum load current is available after the soft-start is completed. The larger the capacitor the slower the ramp of the current limit and the longer the soft-start time. A 100-nF capacitor is usually sufficient for most of the applications. When the EN pin is pulled low, the soft-start capacitor is discharged to ground.

7.3.2 Frequency Select Pin (FREQ)

The frequency select pin FREQ allows to set the switching frequency of the device to 650 kHz (FREQ = low) or 1.2 MHz (FREQ = high). Higher switching frequency improves load transient response but reduces slightly the efficiency. The other benefits of higher switching frequency are a lower output ripple voltage. The use of a 1.2-MHz switching frequency is recommended unless light load efficiency is a major concern.

7.3.3 Undervoltage Lockout (UVLO)

To avoid mis-operation of the device at low input voltages an undervoltage lockout is included that disables the device, if the input voltage falls below 2.4 V.

7.3.4 Thermal Shutdown

A thermal shutdown is implemented to prevent damages due to excessive heat and power dissipation. Typically the thermal shutdown happens at a junction temperature of 150°C. When the thermal shutdown is triggered the device stops switching until the junction temperature falls below typically 136°C. Then the device starts switching again.

7.3.5 Overvoltage Prevention

If overvoltage is detected on the FB pin (typically 3% above the nominal value of 1.238 V) the part stops switching immediately until the voltage on this pin drops to its nominal value. This prevents overvoltage on the output and secures the circuits connected to the output from excessive overvoltage.

7.4 Device Functional Modes

The converter operates in continuous conduction mode (CCM) as soon as the input current increases above half the ripple current in the inductor, for lower load currents it switches into discontinuous conduction mode (DCM). If the load is further reduced, the part starts to skip pulses to maintain the output voltage.

8 Application and Implementation

NOTE

Information in the following applications sections is not part of the TI component specification, and TI does not warrant its accuracy or completeness. TI's customers are responsible for determining suitability of components for their purposes. Customers should validate and test their design implementation to confirm system functionality.

8.1 Application Information

The TPS61087 is designed for output voltages up to 18.5 V with a switch peak current limit of 2.0-A minimum. The device, which operates in a current mode scheme with quasi-constant frequency, is externally compensated for maximum flexibility and stability. The switching frequency is selectable between 650 kHz and 1.2 MHz, and the input voltage range is 2.3 V to 6.0 V. To control the inrush current at start-up a soft-start pin is available. The following section provides a step-by-step design approach for configuring the TPS61087 as a voltage regulating boost converter.

8.2 Typical Application

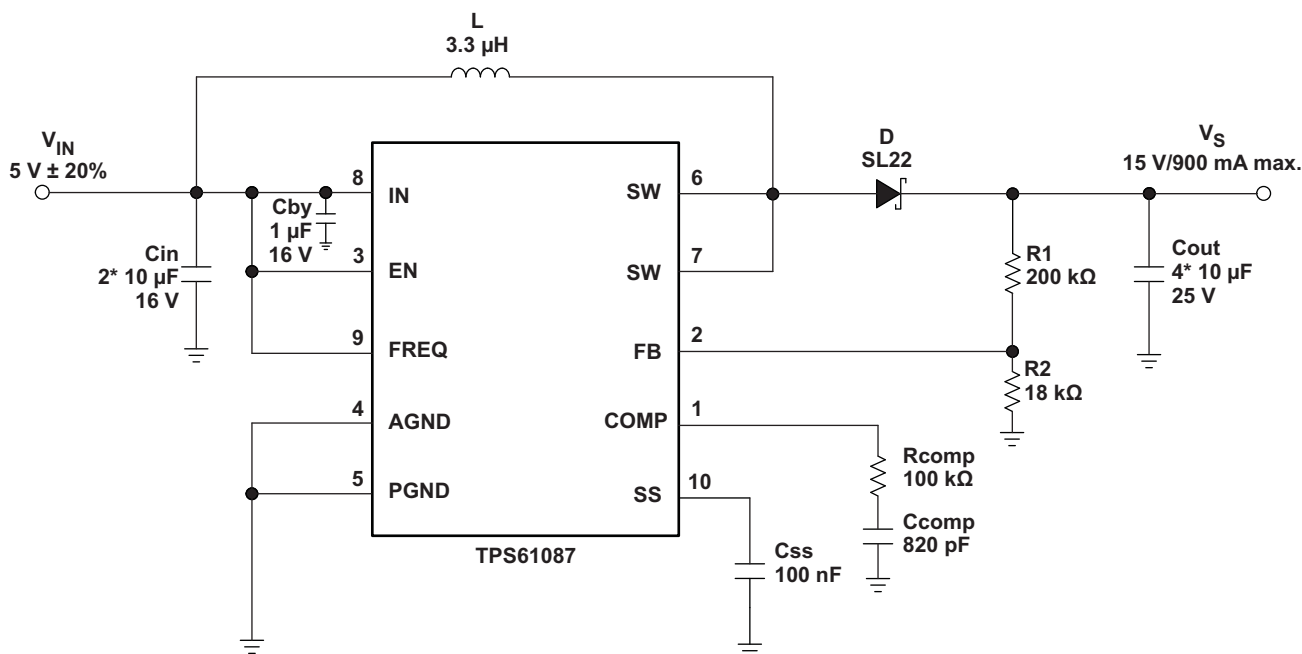

Figure 8. Typical Application, 5 V to 15 V ($f_s = 1.2$ MHz)

8.2.1 Design Requirements

Table 2. TPS61087 15-V Output Design Requirements

PARAMETERS	VALUES
Input Voltage	5 V ± 20%
Output Voltage	15 V
Output Current	900 mA
Switching Frequency	1.2 MHz

8.2.2 Detailed Design Procedure

The first step in the design procedure is to verify that the maximum possible output current of the boost converter supports the specific application requirements. A simple approach is to estimate the converter efficiency, by taking the efficiency numbers from the provided efficiency curves or to use a worst case assumption for the expected efficiency, for example, 90%.

1. Duty cycle, D :

$$D = 1 - \frac{V_{IN} \cdot \eta}{V_S} \quad (1)$$

2. Maximum output current, $I_{out(max)}$:

$$I_{out(max)} = \left(I_{LIM(min)} - \frac{\Delta I_L}{2} \right) \cdot (1 - D) \quad (2)$$

3. Peak switch current in application, I_{swpeak} :

$$I_{swpeak} = \frac{\Delta I_L}{2} + \frac{I_{out}}{1 - D} \quad (3)$$

with the inductor peak-to-peak ripple current, ΔI_L

$$\Delta I_L = \frac{V_{IN} \cdot D}{f_S \cdot L} \quad (4)$$

and

V_{IN}	Minimum input voltage
V_S	Output voltage
$I_{LIM(min)}$	Converter switch current limit (minimum switch current limit = 3.2 A)
f_S	Converter switching frequency (typically 1.2 MHz or 650 kHz)
L	Selected inductor value
η	Estimated converter efficiency (use the number from the efficiency plots or 90% as an estimation)

The peak switch current is the steady state peak switch current that the integrated switch, inductor and external Schottky diode has to be able to handle. The calculation must be done for the minimum input voltage where the peak switch current is the highest.

8.2.2.1 Inductor Selection

The TPS61087 is designed to work with a wide range of inductors. The main parameter for the inductor selection is the saturation current of the inductor which should be higher than the peak switch current as calculated in the [Detailed Design Procedure](#) section with additional margin to cover for heavy load transients. An alternative, more conservative, is to choose an inductor with a saturation current at least as high as the maximum switch current limit of 4.8 A. The other important parameter is the inductor DC resistance. Usually the lower the DC resistance the higher the efficiency. It is important to note that the inductor DC resistance is not the only parameter determining the efficiency. Especially for a boost converter where the inductor is the energy storage element, the type and core material of the inductor influences the efficiency as well. At high switching frequencies of 1.2 MHz inductor core losses, proximity effects and skin effects become more important. Usually an inductor with a larger form factor gives higher efficiency. The efficiency difference between different inductors can vary between 2% to 10%. For the TPS61087, inductor values between 3 μH and 6 μH are a good choice with a switching frequency of 1.2 MHz, typically 3.3 μH . At 650 kHz TI recommends inductors between 6 μH and 13 μH , typically 6.8 μH . Possible inductors are shown in [Table 3](#).

Typically, TI recommends an inductor current ripple below 35% of the average inductor current. Therefore, the following equation can be used to calculate the inductor value, L :

$$L = \left(\frac{V_{IN}}{V_S} \right)^2 \cdot \left(\frac{V_S - V_{IN}}{I_{out} \cdot f_S} \right) \cdot \left(\frac{\eta}{0.35} \right) \quad (5)$$

with

V_{IN}	Minimum input voltage
V_S	Output voltage
I_{out}	Maximum output current in the application
f_S	Converter switching frequency (typically 1.2 MHz or 650 kHz)
η	Estimated converter efficiency (use the number from the efficiency plots or 90% as an estimation)

Table 3. Inductor Selection

L (μ H)	SUPPLIER	COMPONENT CODE	SIZE (LxWxH mm)	DCR TYP (m Ω)	I _{sat} (A)
1.2 MHz					
4.2	Sumida	CDRH5D28	5.7 × 5.7 × 3	23	2.2
4.7	Würth Elektronik	7447785004	5.9 × 6.2 × 3.3	60	2.5
5	Coilcraft	MSS7341	7.3 × 7.3 × 4.1	24	2.9
5	Sumida	CDRH6D28	7 × 7 × 3	23	2.4
4.6	Sumida	CDR7D28	7.6 × 7.6 × 3	38	3.15
4.7	Würth Elektronik	7447789004	7.3 × 7.3 × 3.2	33	3.9
3.3	Würth Elektronik	7447789003	7.3 × 7.3 × 3.2	30	4.2
650 kHz					
10	Würth Elektronik	744778910	7.3 × 7.3 × 3.2	51	2.2
10	Sumida	CDRH8D28	8.3 × 8.3 × 3	36	2.7
6.8	Sumida	CDRH6D26HPNP	7 × 7 × 2.8	52	2.9
6.2	Sumida	CDRH8D58	8.3 × 8.3 × 6	25	3.3
10	Coilcraft	DS3316P	12.95 × 9.40 × 5.08	80	3.5
10	Sumida	CDRH8D43	8.3 × 8.3 × 4.5	29	4
6.8	Würth Elektronik	74454068	12.7 × 10 × 4.9	55	4.1

8.2.2.2 Rectifier Diode Selection

To achieve high efficiency a Schottky type should be used for the rectifier diode. The reverse voltage rating should be higher than the maximum output voltage of the converter. The averaged rectified forward current I_{avg} , the Schottky diode needs to be rated for, is equal to the output current I_{out} :

$$I_{avg} = I_{out} \quad (6)$$

Usually a Schottky diode with 2-A maximum average rectified forward current rating is sufficient for most applications. The Schottky rectifier can be selected with lower forward current capability depending on the output current I_{out} but has to be able to dissipate the power. The dissipated power, P_D , is the average rectified forward current times the diode forward voltage, $V_{forward}$.

$$P_D = I_{avg} \cdot V_{forward} \quad (7)$$

Typically, the diode should be able to dissipate around 500 mW depending on the load current and forward voltage.

Table 4. Rectifier Diode Selection

CURRENT RATING I_{avg}	V_r	$V_{forward} I_{avg}$	SUPPLIER	COMPONENT CODE
2 A	20 V	0.44 V / 2 A	Vishay Semiconductor	SL22
2 A	20 V	0.5 V / 2 A	Fairchild Semiconductor	SS22

8.2.2.3 Setting the Output Voltage

The output voltage is set by an external resistor divider. Typically, a minimum current of 50 μ A flowing through the feedback divider gives good accuracy and noise covering. A standard low-side resistor of 18 k Ω is typically selected. The resistors are then calculated as:

$$R2 = \frac{V_{FB}}{70\mu A} \approx 18k\Omega \quad R1 = R2 \cdot \left(\frac{V_s}{V_{FB}} - 1 \right)$$

$$V_{FB} = 1.238V$$

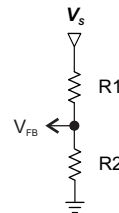

(8)

8.2.2.4 Compensation (COMP)

The regulator loop can be compensated by adjusting the external components connected to the COMP pin. The COMP pin is the output of the internal transconductance error amplifier.

Standard values of $R_{COMP} = 16\text{ k}\Omega$ and $C_{COMP} = 2.7\text{ nF}$ will work for the majority of the applications.

See [Table 5](#) for dedicated compensation networks giving an improved load transient response. The following equations can be used to calculate R_{COMP} and C_{COMP} :

$$R_{COMP} = \frac{110 \cdot V_{IN} \cdot V_s \cdot C_{out}}{L \cdot I_{out}} \quad C_{COMP} = \frac{V_s \cdot C_{out}}{7.5 \cdot I_{out} \cdot R_{COMP}}$$

with

- V_{IN} Minimum input voltage
- V_s Output voltage
- C_{out} Output capacitance
- L Inductor value, for example, 3.3 μ H or 6.8 μ H
- I_{out} Maximum output current in the application

Make sure that $R_{COMP} < 120\text{ k}\Omega$ and $C_{COMP} > 820\text{ pF}$, independent of the results of the above formulas.

Table 5. Recommended Compensation Network Values at High/Low Frequency

FREQUENCY	L	V_s	$V_{IN} \pm 20\%$	R_{COMP}	C_{COMP}
High (1.2 MHz)	3.3 μ H	15 V	5 V	100 k Ω	820 pF
			3.3 V	91 k Ω	1.2 nF
		12 V	5 V	68 k Ω	820 pF
			3.3 V	68 k Ω	1.2 nF
		9 V	5 V	39 k Ω	820 pF
			3.3 V	39 k Ω	1.2 nF
Low (650 kHz)	6.8 μ H	15 V	5 V	51 k Ω	1.5 nF
			3.3 V	47 k Ω	2.7 nF
		12 V	5 V	33 k Ω	1.5 nF
			3.3 V	33 k Ω	2.7 nF
		9 V	5 V	18 k Ω	1.5 nF
			3.3 V	18 k Ω	2.7 nF

Table 5 gives conservative R_{COMP} and C_{COMP} values for certain inductors, input and output voltages providing a very stable system. For a faster response time, a higher R_{COMP} value can be used to enlarge the bandwidth, as well as a slightly lower value of C_{COMP} to keep enough phase margin. These adjustments should be performed in parallel with the load transient response monitoring of TPS61087.

8.2.2.5 Input Capacitor Selection

For good input voltage filtering low ESR ceramic capacitors are recommended. TPS61087 has an analog input IN. Therefore, a 1- μ F bypass is highly recommended as close as possible to the IC from IN to GND.

Two 10- μ F (or one 22- μ F) ceramic input capacitors are sufficient for most of the applications. For better input voltage filtering this value can be increased. See Table 6 and typical applications for input capacitor recommendation.

8.2.2.6 Output Capacitor Selection

For best output voltage filtering a low ESR output capacitor like ceramic capacitor is recommended. Four 10- μ F ceramic output capacitors (or two-22 μ F) work for most of the applications. Higher capacitor values can be used to improve the load transient response. See Table 6 for the selection of the output capacitor.

Table 6. Rectifier Input and Output Capacitor Selection

	CAPACITOR/SIZE	VOLTAGE RATING	SUPPLIER	COMPONENT CODE
C_{IN}	22 μ F/1206	16 V	Taiyo Yuden	EMK316 BJ 226ML
IN bypass	1 μ F/0603	16 V	Taiyo Yuden	EMK107 BJ 105KA
C_{OUT}	10 μ F/1206	25 V	Taiyo Yuden	TMK316 BJ 106KL

To calculate the output voltage ripple, the following equation can be used:

$$\Delta V_C = \frac{V_S - V_{IN}}{V_S \cdot f_S} \cdot \frac{I_{out}}{C_{out}} \quad \Delta V_{C_ESR} = I_{L(peak)} \cdot R_{C_ESR} \quad (10)$$

with

ΔV_C	Output voltage ripple dependent on output capacitance, output current and switching frequency
V_S	Output voltage
V_{IN}	Minimum input voltage of boost converter
f_S	Converter switching frequency (typically 1.2 MHz or 650 kHz)
I_{out}	Output capacitance
ΔV_{C_ESR}	Output voltage ripple due to output capacitors ESR (equivalent series resistance)
I_{SWPEAK}	Inductor peak switch current in the application
R_{C_ESR}	Output capacitors equivalent series resistance (ESR)

ΔV_{C_ESR} can be neglected in many cases since ceramic capacitors provide low ESR.

8.2.3 Application Curves

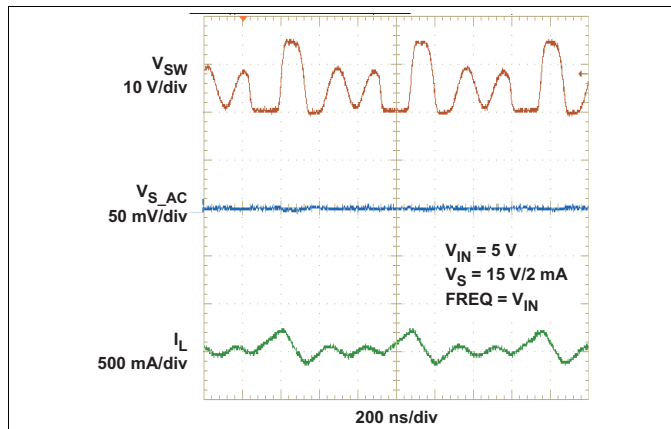

Figure 9. PWM Switching Discontinuous Conduction Mode

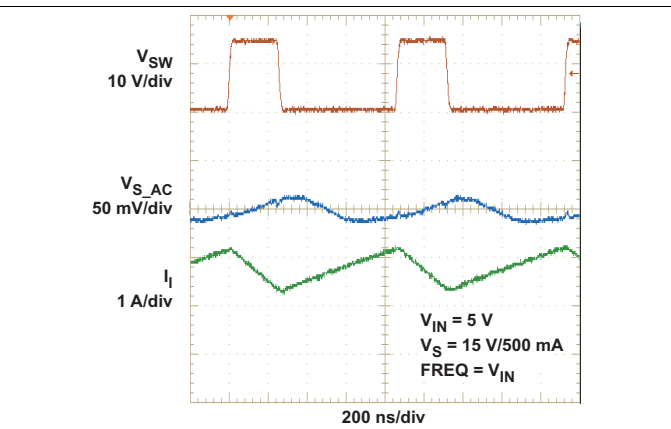

Figure 10. PWM Switching Continuous Conduction Mode

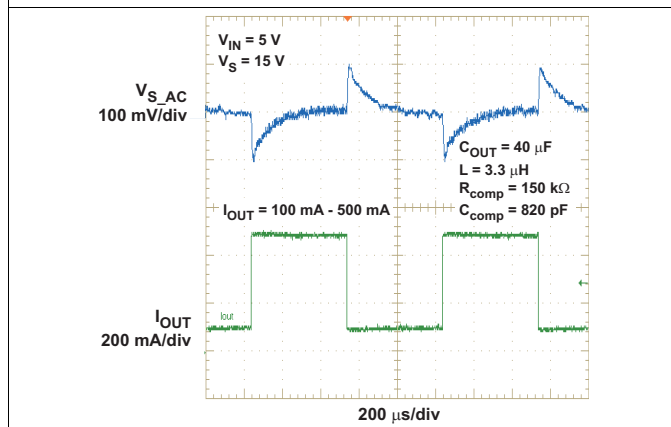

Figure 11. Load Transient Response High Frequency (1.2 MHz)

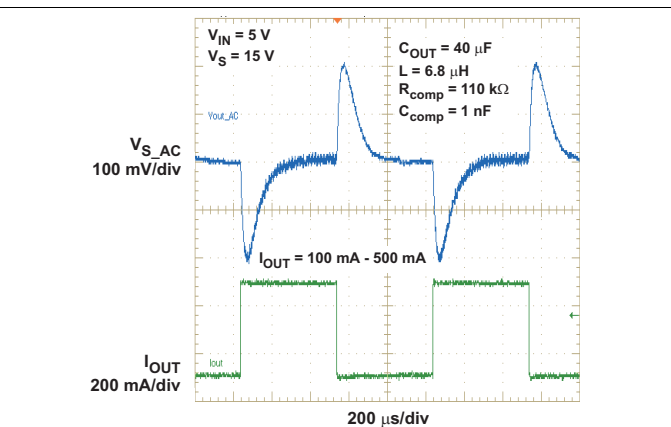

Figure 12. Load Transient Response Low Frequency (650 kHz)

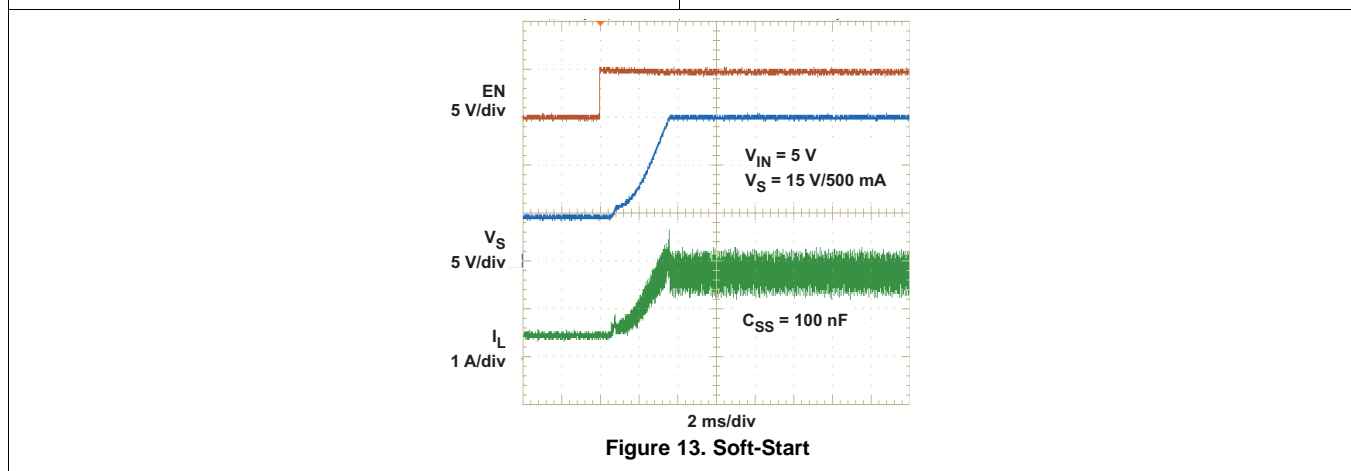

Figure 13. Soft-Start

8.3 System Examples

8.3.1 General Boost Application Circuits

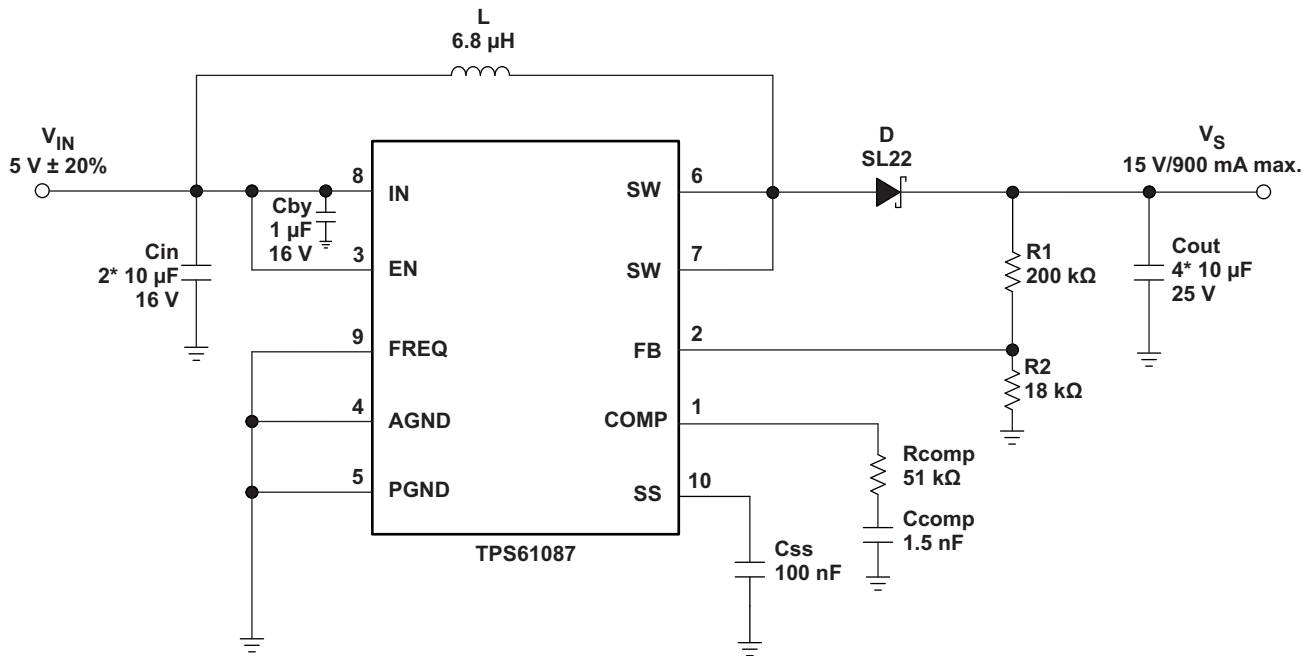

Figure 14. Typical Application, 5 V to 15 V ($f_s = 650\ \text{kHz}$)

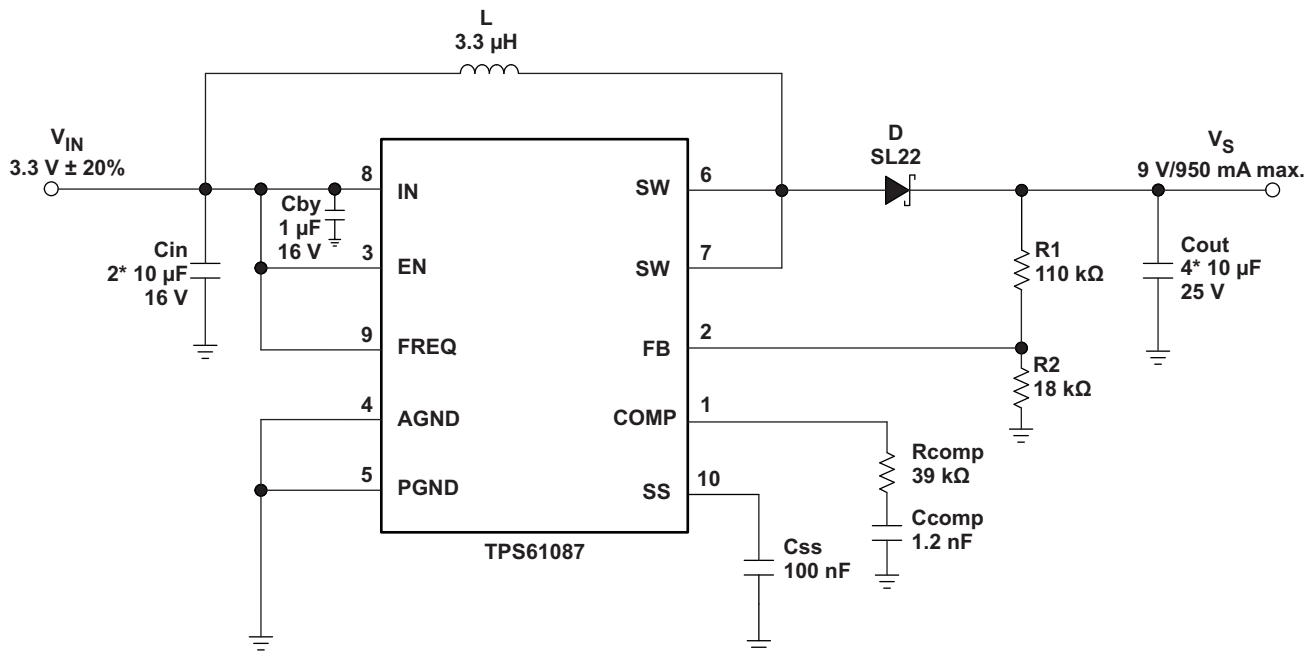
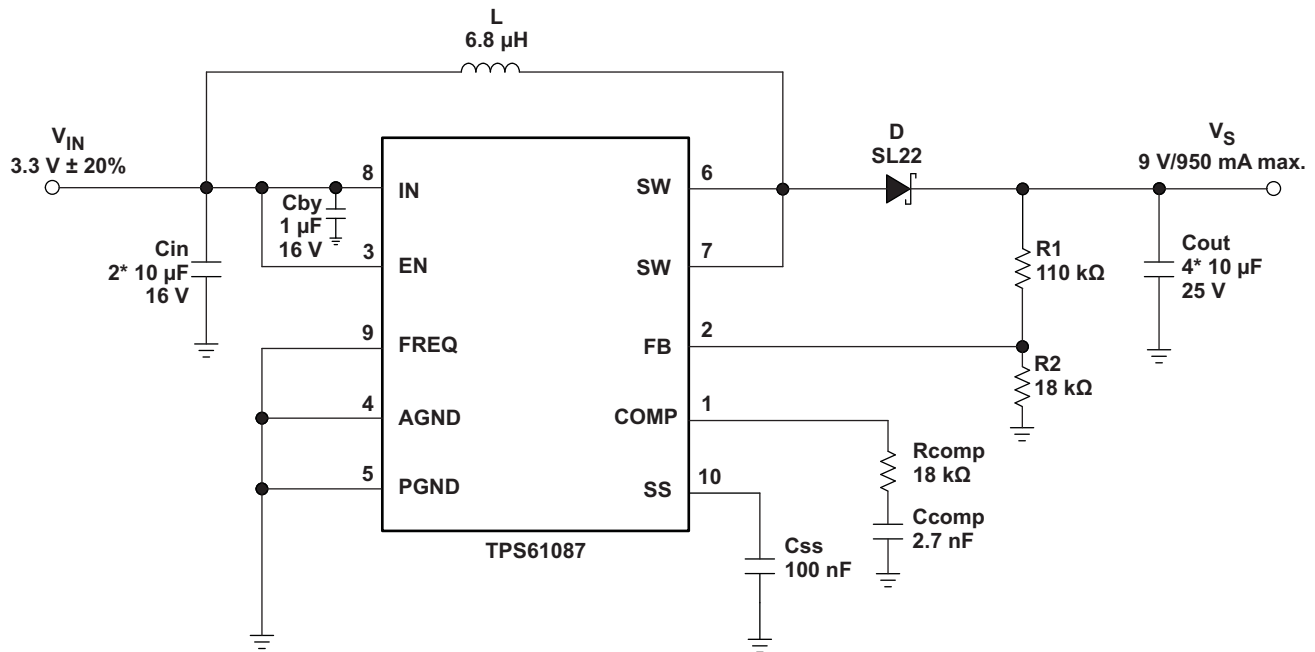
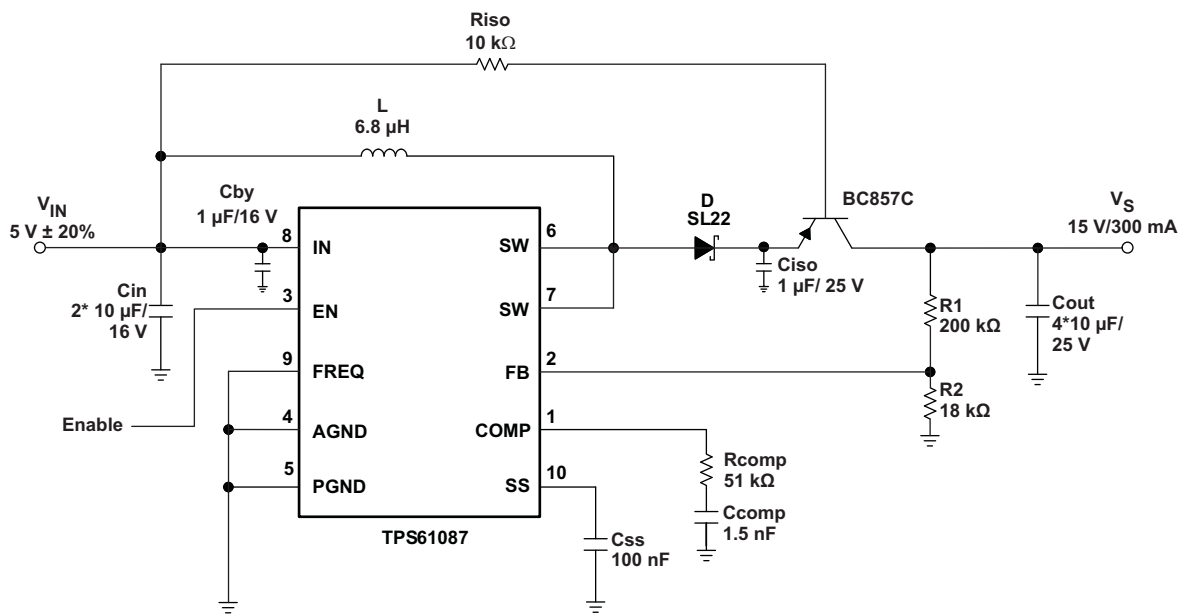

Figure 15. Typical Application, 3.3 V to 9 V ($f_s = 1.2\ \text{MHz}$)

System Examples (continued)

Figure 16. Typical Application, 3.3 V to 9 V (f_s = 650 kHz)

Figure 17. Typical Application With External Load Disconnect Switch

System Examples (continued)

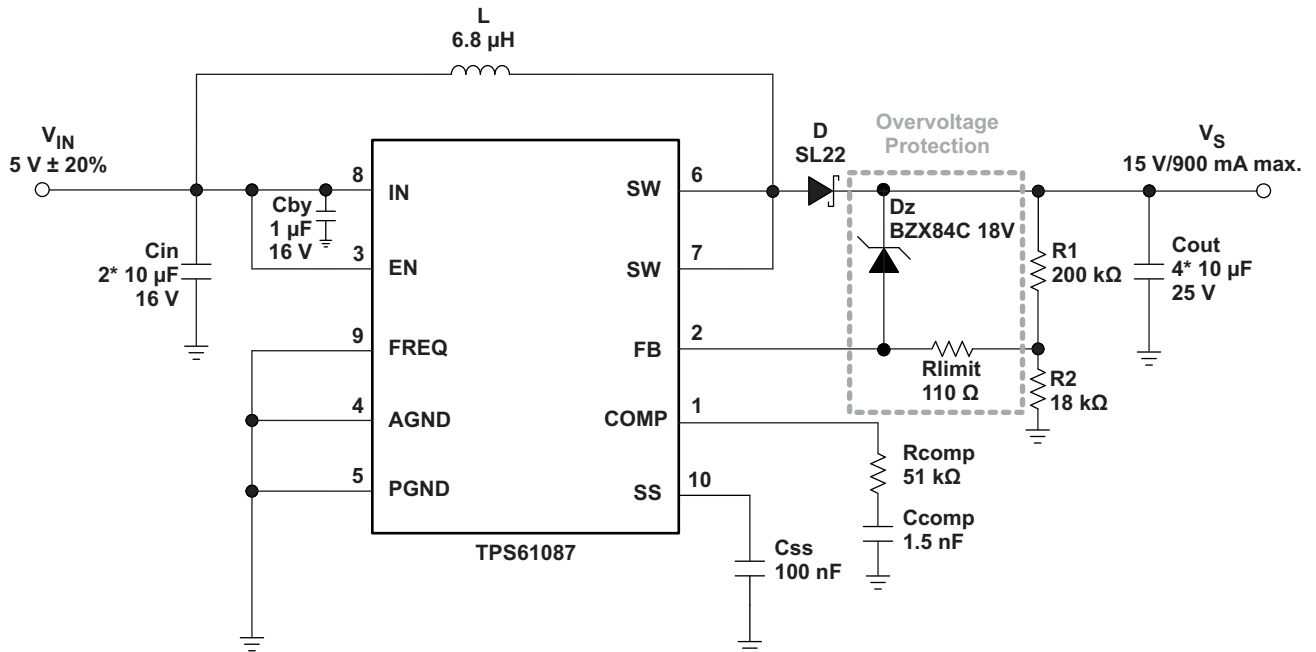

Figure 18. Typical Application, 5 V to 15 V ($f_s = 1.2\text{ MHz}$) With Overvoltage Protection

System Examples (continued)

8.3.2 TFT LCD Application

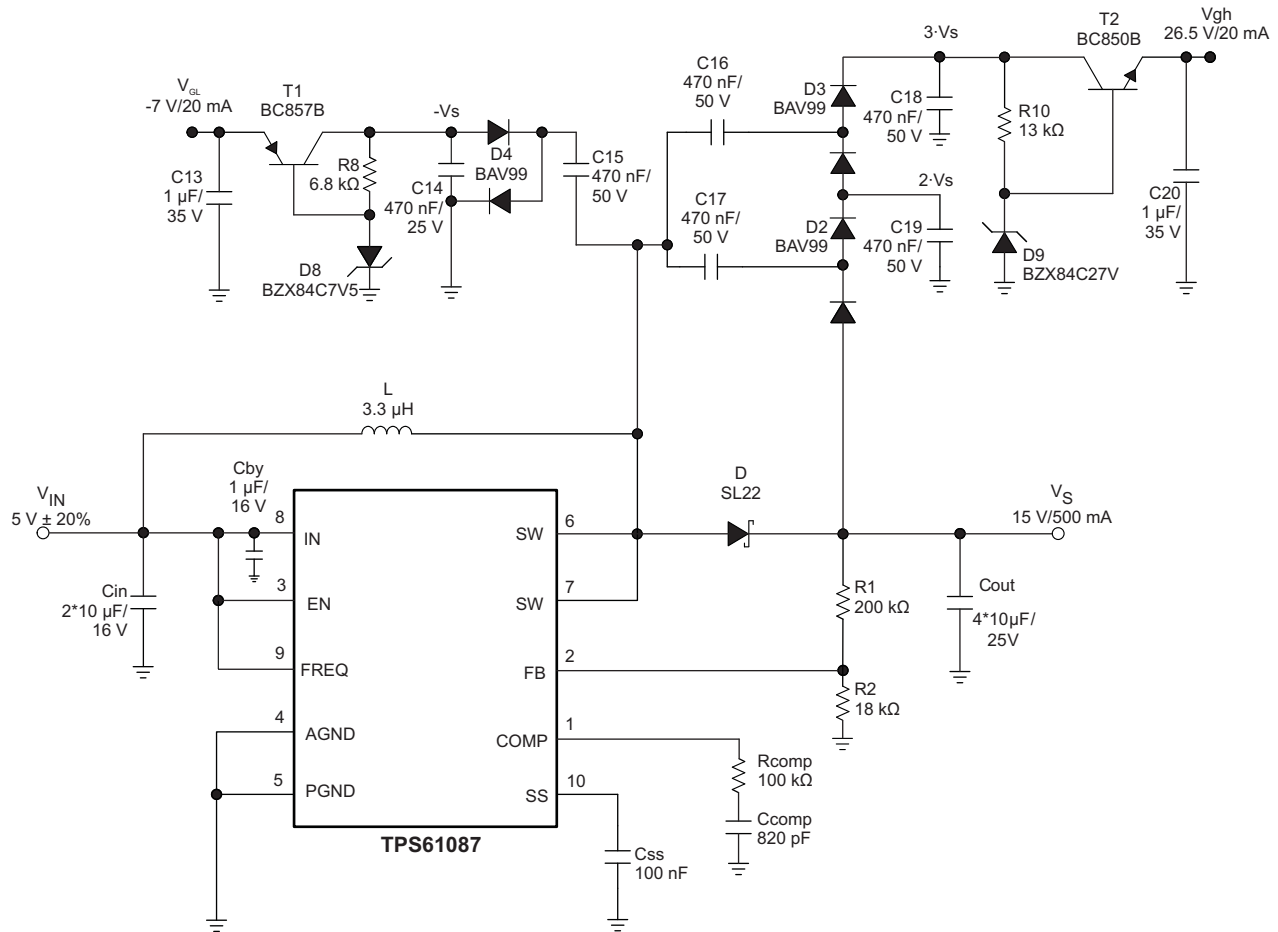

Figure 19. Typical Application 5 V to 15 V ($f_s = 1.2$ MHz) for TFT LCD With External Charge Pumps (VGH, VGL)

System Examples (continued)

8.3.3 White LED Applications

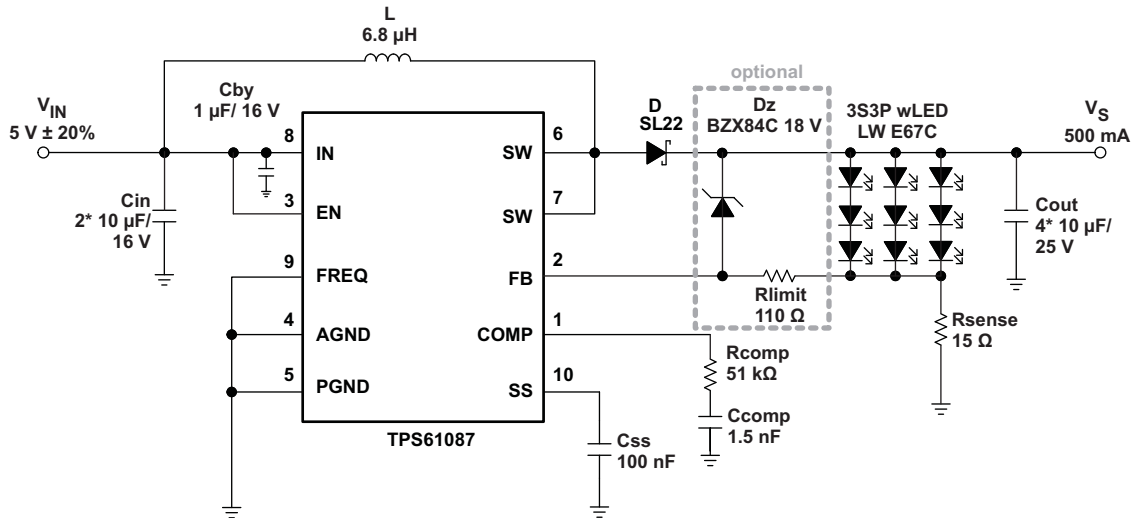

Figure 20. Simple Application (5 V Input Voltage) ($f_s = 650$ kHz) for wLED Supply (3S3P) (With Optional Clamping Zener Diode)

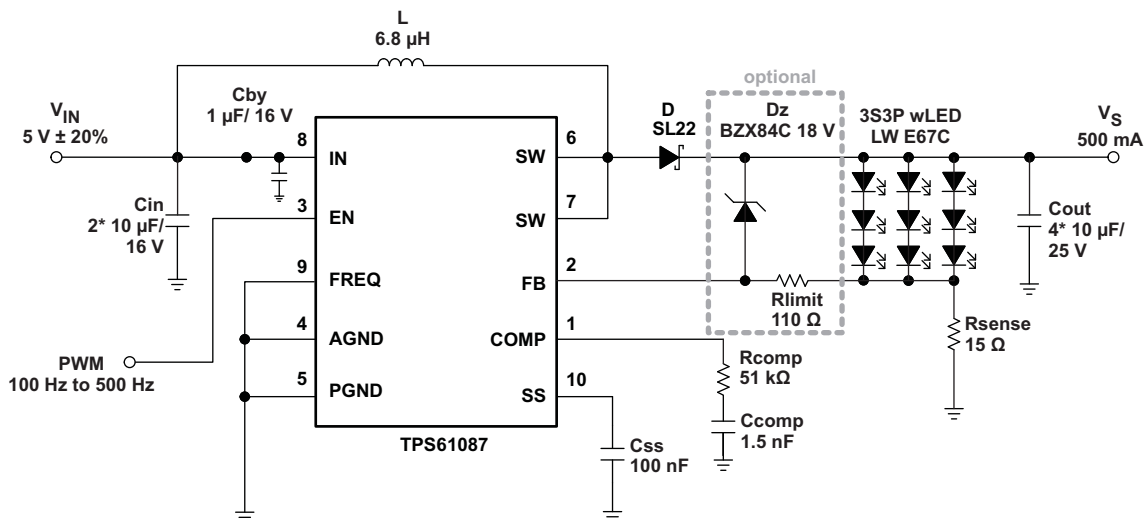

Figure 21. Simple Application (5 V Input Voltage) ($f_s = 650$ kHz) for wLED Supply (3S3P) With Adjustable Brightness Control Using a PWM Signal on the Enable Pin (With Optional Clamping Zener Diode)

System Examples (continued)

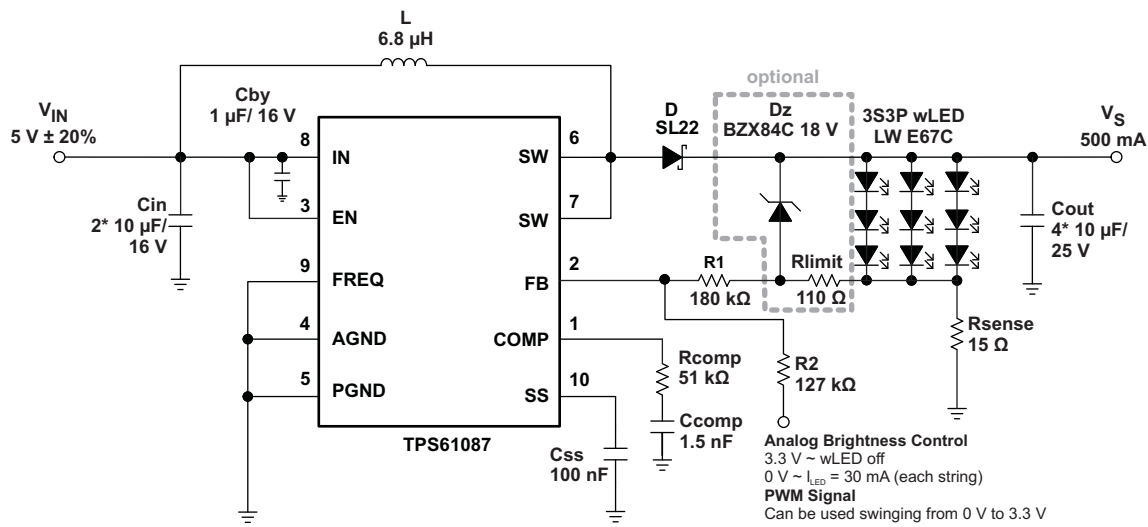

Figure 22. Simple Application (5 V Input Voltage) ($f_s = 650$ kHz) for wLED Supply (3S3P) With Adjustable Brightness Control Using an Analog Signal on the Feedback Pin (With Optional Clamping Zener Diode)

9 Power Supply Recommendations

The TPS61087 is designed to operate from an input voltage supply range from 2.3 V to 6.0 V. The power supply to the TPS61087 must have a current rating according to the supply voltage, output voltage, and output current of the TPS61087.

10 Layout

10.1 Layout Guidelines

For all switching power supplies, the layout is an important step in the design, especially at high peak currents and high switching frequencies. If the layout is not carefully done, the regulator could show stability problems as well as EMI problems. Therefore, use wide and short traces for the main current path and for the power ground tracks. The input capacitor, output capacitor, and the inductor should be placed as close as possible to the IC. Use a common ground node for power ground and a different one for control ground to minimize the effects of ground noise. Connect these ground nodes at the GND terminal of the IC. The most critical current path for all boost converters is from the switching FET, through the rectifier diode, then the output capacitors, and back to ground of the switching FET. Therefore, the output capacitors and their traces should be placed on the same board layer as the IC and as close as possible between the SW pin and the GND terminal of the IC..

10.2 Layout Example

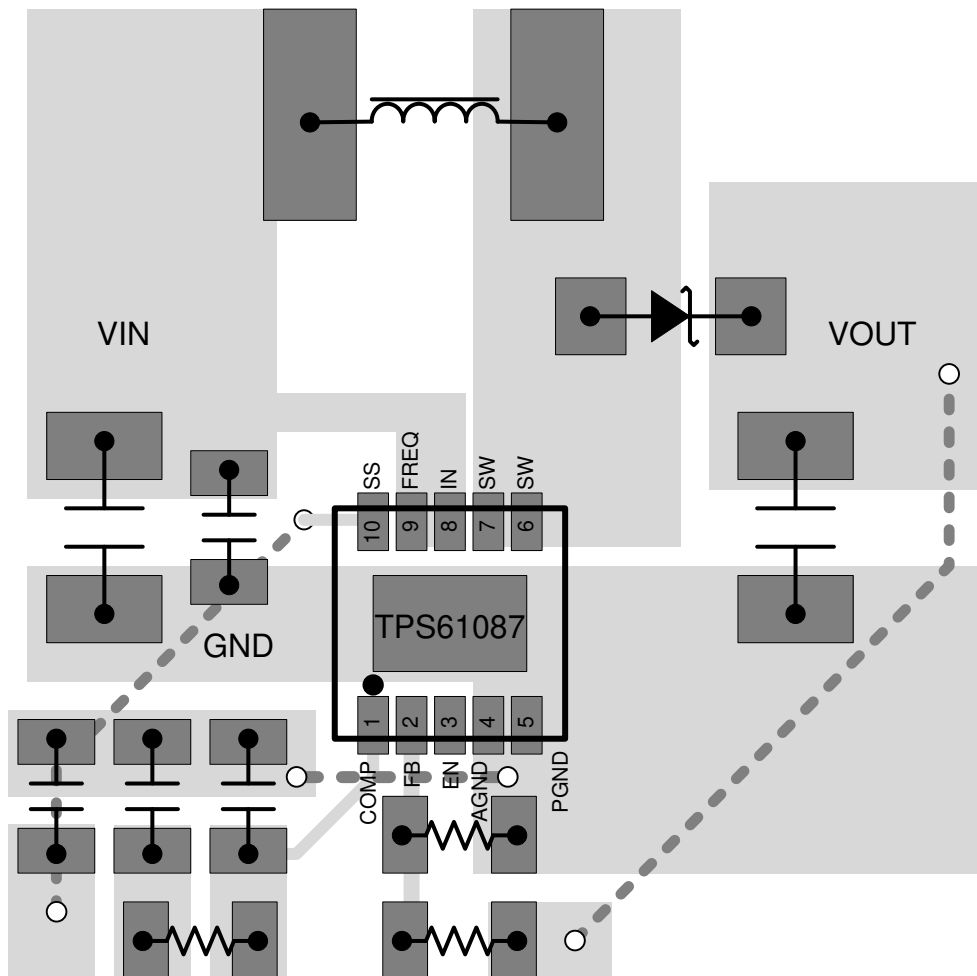

Figure 23. TPS61087 Layout Example

11 器件和文档支持

11.1 第三方产品免责声明

TI 发布的与第三方产品或服务有关的信息，不能构成与此类产品或服务或保修的适用性有关的认可，不能构成此类产品或服务单独或与任何 TI 产品或服务一起的表示或认可。

11.2 商标

All trademarks are the property of their respective owners.

11.3 静电放电警告



这些装置包含有限的内置 ESD 保护。存储或装卸时，应将导线一起截短或将装置放置于导电泡棉中，以防止 MOS 门极遭受静电损伤。

11.4 Glossary

[SLYZ022](#) — *TI Glossary*.

This glossary lists and explains terms, acronyms, and definitions.

12 机械、封装和可订购信息

以下页面包含机械、封装和可订购信息。这些信息是指定器件的最新可用数据。数据如有变更，恕不另行通知，且不会对此文档进行修订。如需获取此数据表的浏览器版本，请查阅左侧的导航栏。

PACKAGING INFORMATION

Orderable part number	Status (1)	Material type (2)	Package Pins	Package qty Carrier	RoHS (3)	Lead finish/ Ball material (4)	MSL rating/ Peak reflow (5)	Op temp (°C)	Part marking (6)
TPS61087DRCR	Active	Production	VSON (DRC) 10	3000 LARGE T&R	Yes	NIPDAU	Level-2-260C-1 YEAR	-40 to 125	PMOQ
TPS61087DRCR.A	Active	Production	VSON (DRC) 10	3000 LARGE T&R	Yes	NIPDAU	Level-2-260C-1 YEAR	-40 to 125	PMOQ
TPS61087DRCR.B	Active	Production	VSON (DRC) 10	3000 LARGE T&R	Yes	NIPDAU	Level-2-260C-1 YEAR	-40 to 125	PMOQ
TPS61087DRCRG4	Active	Production	VSON (DRC) 10	3000 LARGE T&R	Yes	NIPDAU	Level-2-260C-1 YEAR	-40 to 85	PMOQ
TPS61087DRCT	Active	Production	VSON (DRC) 10	250 SMALL T&R	Yes	NIPDAU	Level-2-260C-1 YEAR	-40 to 125	PMOQ
TPS61087DRCT.A	Active	Production	VSON (DRC) 10	250 SMALL T&R	Yes	NIPDAU	Level-2-260C-1 YEAR	-40 to 125	PMOQ
TPS61087DRCT.B	Active	Production	VSON (DRC) 10	250 SMALL T&R	Yes	NIPDAU	Level-2-260C-1 YEAR	-40 to 125	PMOQ
TPS61087DRCTG4	Active	Production	VSON (DRC) 10	250 SMALL T&R	Yes	NIPDAU	Level-2-260C-1 YEAR	-40 to 125	PMOQ
TPS61087DRCTG4.A	Active	Production	VSON (DRC) 10	250 SMALL T&R	Yes	NIPDAU	Level-2-260C-1 YEAR	-40 to 125	PMOQ
TPS61087DRCTG4.B	Active	Production	VSON (DRC) 10	250 SMALL T&R	Yes	NIPDAU	Level-2-260C-1 YEAR	-40 to 125	PMOQ
TPS61087DSCR	Active	Production	WSON (DSC) 10	3000 LARGE T&R	Yes	NIPDAU	Level-2-260C-1 YEAR	-40 to 125	PMWI
TPS61087DSCR.B	Active	Production	WSON (DSC) 10	3000 LARGE T&R	Yes	NIPDAU	Level-2-260C-1 YEAR	-40 to 125	PMWI
TPS61087DSCRG4	Active	Production	WSON (DSC) 10	3000 LARGE T&R	Yes	NIPDAU	Level-2-260C-1 YEAR	-40 to 125	PMWI
TPS61087DSCRG4.B	Active	Production	WSON (DSC) 10	3000 LARGE T&R	Yes	NIPDAU	Level-2-260C-1 YEAR	-40 to 125	PMWI
TPS61087DSCT	Active	Production	WSON (DSC) 10	250 SMALL T&R	Yes	NIPDAU	Level-2-260C-1 YEAR	-40 to 125	PMWI
TPS61087DSCT.B	Active	Production	WSON (DSC) 10	250 SMALL T&R	Yes	NIPDAU	Level-2-260C-1 YEAR	-40 to 125	PMWI

(1) **Status:** For more details on status, see our [product life cycle](#).

(2) **Material type:** When designated, preproduction parts are prototypes/experimental devices, and are not yet approved or released for full production. Testing and final process, including without limitation quality assurance, reliability performance testing, and/or process qualification, may not yet be complete, and this item is subject to further changes or possible discontinuation. If available for ordering, purchases will be subject to an additional waiver at checkout, and are intended for early internal evaluation purposes only. These items are sold without warranties of any kind.

(3) **RoHS values:** Yes, No, RoHS Exempt. See the [TI RoHS Statement](#) for additional information and value definition.

(4) **Lead finish/Ball material:** Parts may have multiple material finish options. Finish options are separated by a vertical ruled line. Lead finish/Ball material values may wrap to two lines if the finish value exceeds the maximum column width.

(5) **MSL rating/Peak reflow:** The moisture sensitivity level ratings and peak solder (reflow) temperatures. In the event that a part has multiple moisture sensitivity ratings, only the lowest level per JEDEC standards is shown. Refer to the shipping label for the actual reflow temperature that will be used to mount the part to the printed circuit board.

(6) Part marking: There may be an additional marking, which relates to the logo, the lot trace code information, or the environmental category of the part.

Multiple part markings will be inside parentheses. Only one part marking contained in parentheses and separated by a "-" will appear on a part. If a line is indented then it is a continuation of the previous line and the two combined represent the entire part marking for that device.

Important Information and Disclaimer:The information provided on this page represents TI's knowledge and belief as of the date that it is provided. TI bases its knowledge and belief on information provided by third parties, and makes no representation or warranty as to the accuracy of such information. Efforts are underway to better integrate information from third parties. TI has taken and continues to take reasonable steps to provide representative and accurate information but may not have conducted destructive testing or chemical analysis on incoming materials and chemicals. TI and TI suppliers consider certain information to be proprietary, and thus CAS numbers and other limited information may not be available for release.

In no event shall TI's liability arising out of such information exceed the total purchase price of the TI part(s) at issue in this document sold by TI to Customer on an annual basis.

OTHER QUALIFIED VERSIONS OF TPS61087 :

- Automotive : [TPS61087-Q1](#)

NOTE: Qualified Version Definitions:

- Automotive - Q100 devices qualified for high-reliability automotive applications targeting zero defects

TAPE AND REEL INFORMATION

QUADRANT ASSIGNMENTS FOR PIN 1 ORIENTATION IN TAPE

*All dimensions are nominal

Device	Package Type	Package Drawing	Pins	SPQ	Reel Diameter (mm)	Reel Width W1 (mm)	A0 (mm)	B0 (mm)	K0 (mm)	P1 (mm)	W (mm)	Pin1 Quadrant
TPS61087DRCR	VSON	DRC	10	3000	330.0	12.4	3.3	3.3	1.1	8.0	12.0	Q2
TPS61087DRCR	VSON	DRC	10	3000	330.0	12.4	3.3	3.3	1.1	8.0	12.0	Q2
TPS61087DRCT	VSON	DRC	10	250	180.0	12.4	3.3	3.3	1.1	8.0	12.0	Q2
TPS61087DRCTG4	VSON	DRC	10	250	180.0	12.4	3.3	3.3	1.1	8.0	12.0	Q2
TPS61087DSCR	WSON	DSC	10	3000	330.0	12.4	3.3	3.3	1.1	8.0	12.0	Q2
TPS61087DSCRG4	WSON	DSC	10	3000	330.0	12.4	3.3	3.3	1.1	8.0	12.0	Q2
TPS61087DSCT	WSON	DSC	10	250	180.0	12.4	3.3	3.3	1.1	8.0	12.0	Q2

TAPE AND REEL BOX DIMENSIONS

*All dimensions are nominal

Device	Package Type	Package Drawing	Pins	SPQ	Length (mm)	Width (mm)	Height (mm)
TPS61087DRCR	VSON	DRC	10	3000	353.0	353.0	32.0
TPS61087DRCR	VSON	DRC	10	3000	346.0	346.0	33.0
TPS61087DRCT	VSON	DRC	10	250	210.0	185.0	35.0
TPS61087DRCTG4	VSON	DRC	10	250	210.0	185.0	35.0
TPS61087DSCR	WSON	DSC	10	3000	353.0	353.0	32.0
TPS61087DSCRG4	WSON	DSC	10	3000	353.0	353.0	32.0
TPS61087DSCT	WSON	DSC	10	250	213.0	191.0	35.0

GENERIC PACKAGE VIEW

DRC 10

VSON - 1 mm max height

3 x 3, 0.5 mm pitch

PLASTIC SMALL OUTLINE - NO LEAD

This image is a representation of the package family, actual package may vary.
Refer to the product data sheet for package details.

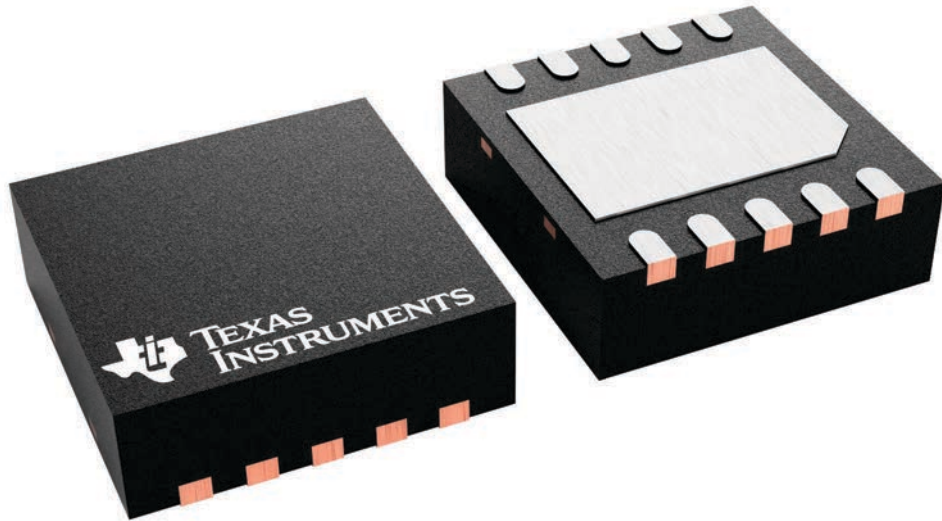

4226193/A

EXAMPLE BOARD LAYOUT

DRC0010J

VSON - 1 mm max height

PLASTIC SMALL OUTLINE - NO LEAD

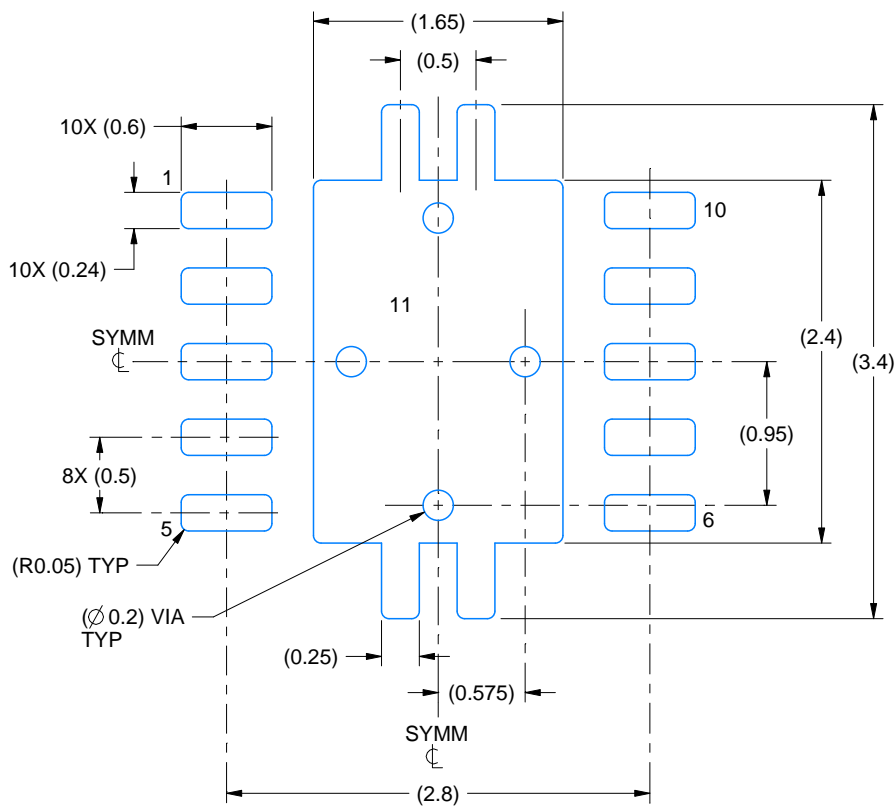

LAND PATTERN EXAMPLE
EXPOSED METAL SHOWN
SCALE:20X

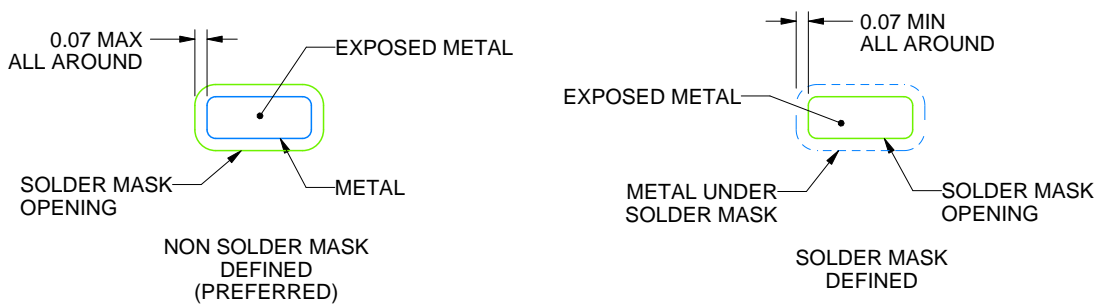

SOLDER MASK DETAILS

4218878/B 07/2018

NOTES: (continued)

4. This package is designed to be soldered to a thermal pad on the board. For more information, see Texas Instruments literature number SLUA271 (www.ti.com/lit/slua271).
5. Vias are optional depending on application, refer to device data sheet. If any vias are implemented, refer to their locations shown on this view. It is recommended that vias under paste be filled, plugged or tented.

EXAMPLE STENCIL DESIGN

DRC0010J

VSON - 1 mm max height

PLASTIC SMALL OUTLINE - NO LEAD

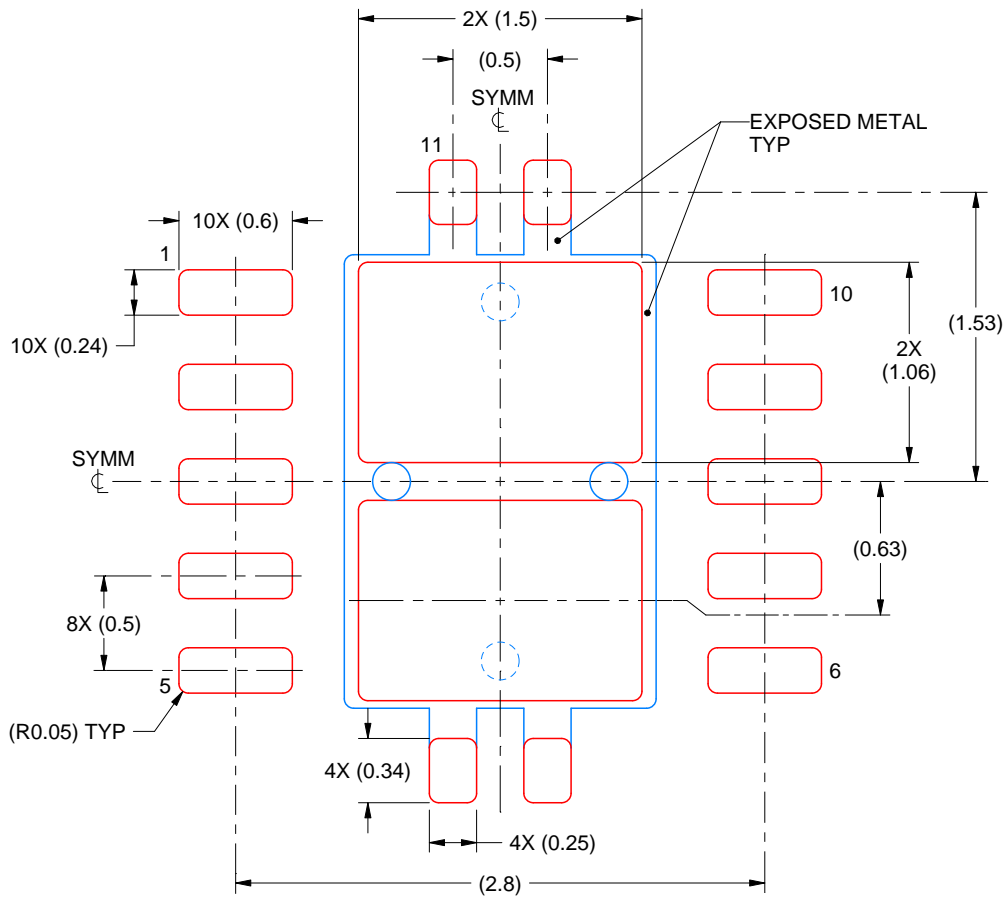

SOLDER PASTE EXAMPLE
BASED ON 0.125 mm THICK STENCIL

EXPOSED PAD 11:
80% PRINTED SOLDER COVERAGE BY AREA
SCALE:25X

4218878/B 07/2018

NOTES: (continued)

6. Laser cutting apertures with trapezoidal walls and rounded corners may offer better paste release. IPC-7525 may have alternate design recommendations.

GENERIC PACKAGE VIEW

DSC 10

WSON - 0.8 mm max height

PLASTIC SMALL OUTLINE - NO LEAD

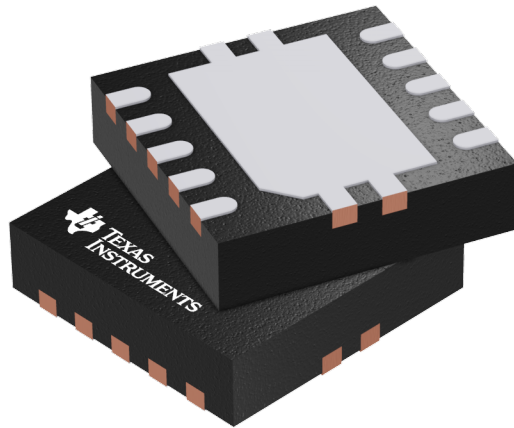

Images above are just a representation of the package family, actual package may vary.
Refer to the product data sheet for package details.

4207383/F

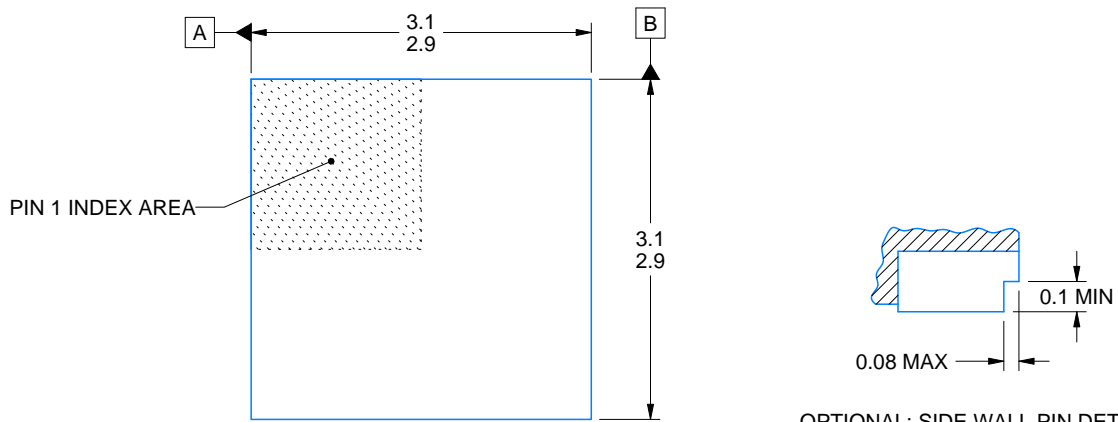
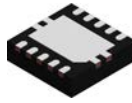

OPTIONAL: SIDE WALL PIN DETAIL
NOTE 4

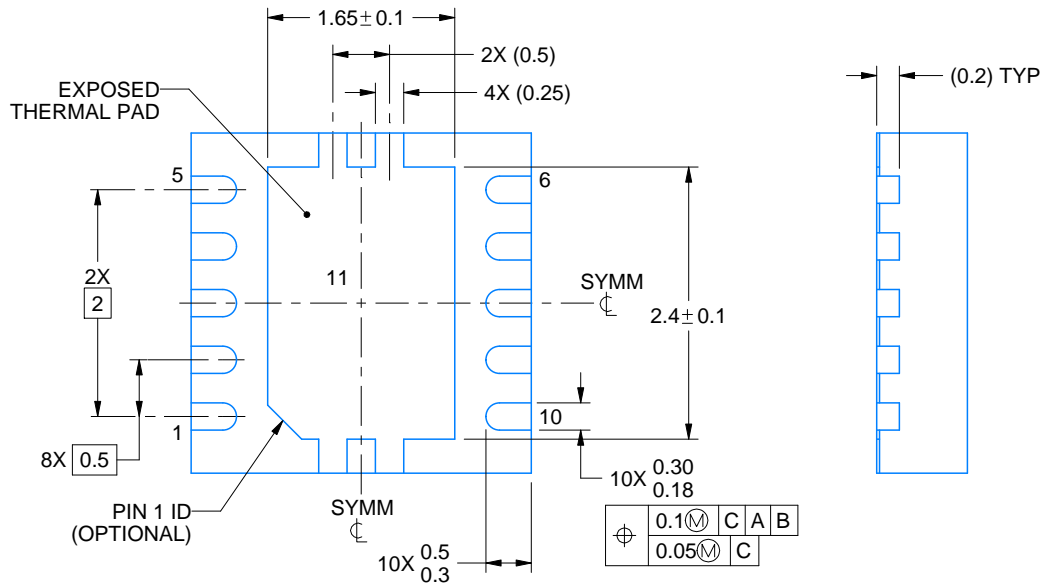
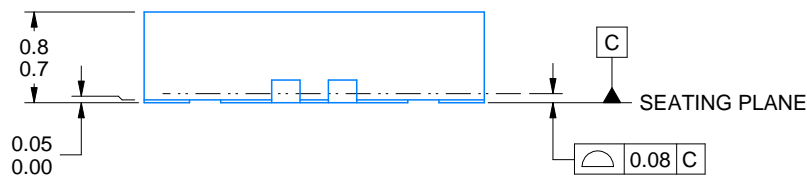

4221826/E 03/2026

NOTES:

1. All linear dimensions are in millimeters. Any dimensions in parenthesis are for reference only. Dimensioning and tolerancing per ASME Y14.5M.
2. This drawing is subject to change without notice.
3. The package thermal pad must be soldered to the printed circuit board for optimal thermal and mechanical performance.
4. Minimum 0.1 mm solder wetting on pin side wall. Available for wettable flank version only.

EXAMPLE BOARD LAYOUT

DSC0010J

WSON - 0.8 mm max height

PLASTIC SMALL OUTLINE - NO LEAD

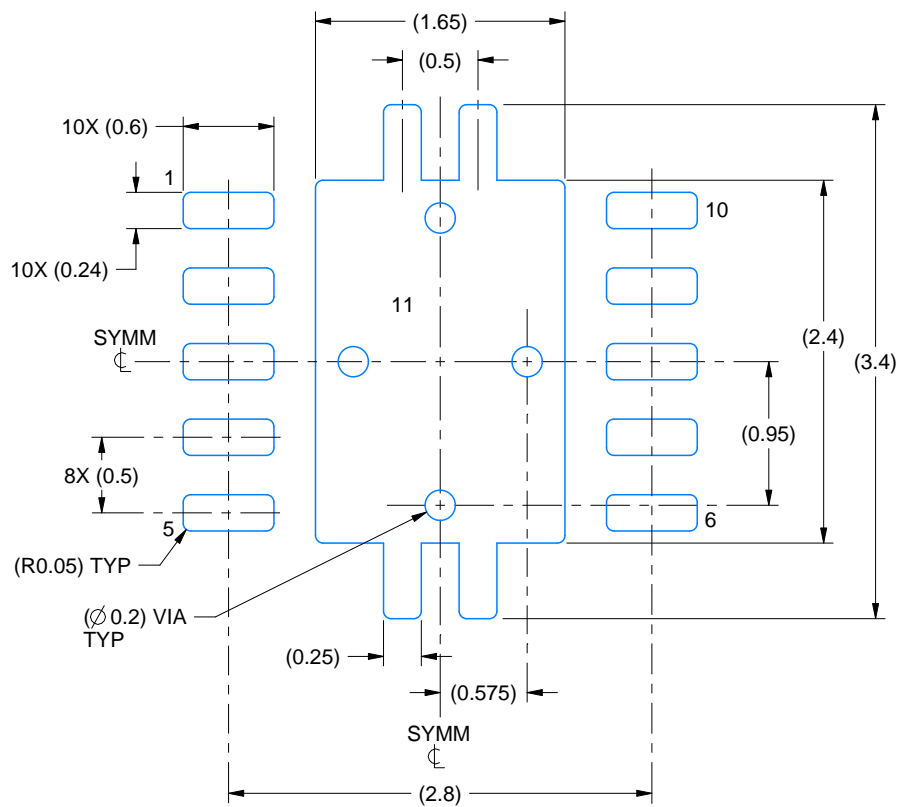

LAND PATTERN EXAMPLE
EXPOSED METAL SHOWN
SCALE:20X

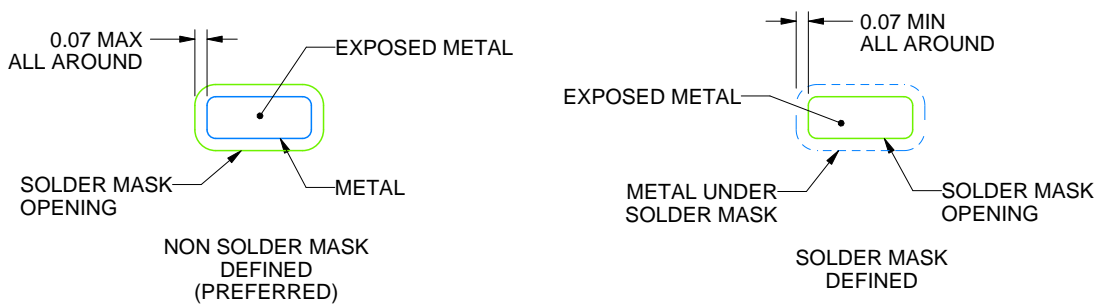

SOLDER MASK DETAILS

4221826/E 03/2026

NOTES: (continued)

5. This package is designed to be soldered to a thermal pad on the board. For more information, see Texas Instruments literature number SLUA271 (www.ti.com/lit/sluea271).
6. Vias are optional depending on application, refer to device data sheet. If any vias are implemented, refer to their locations shown on this view. It is recommended that vias under paste be filled, plugged or tented.

EXAMPLE STENCIL DESIGN

DSC0010J

WSON - 0.8 mm max height

PLASTIC SMALL OUTLINE - NO LEAD

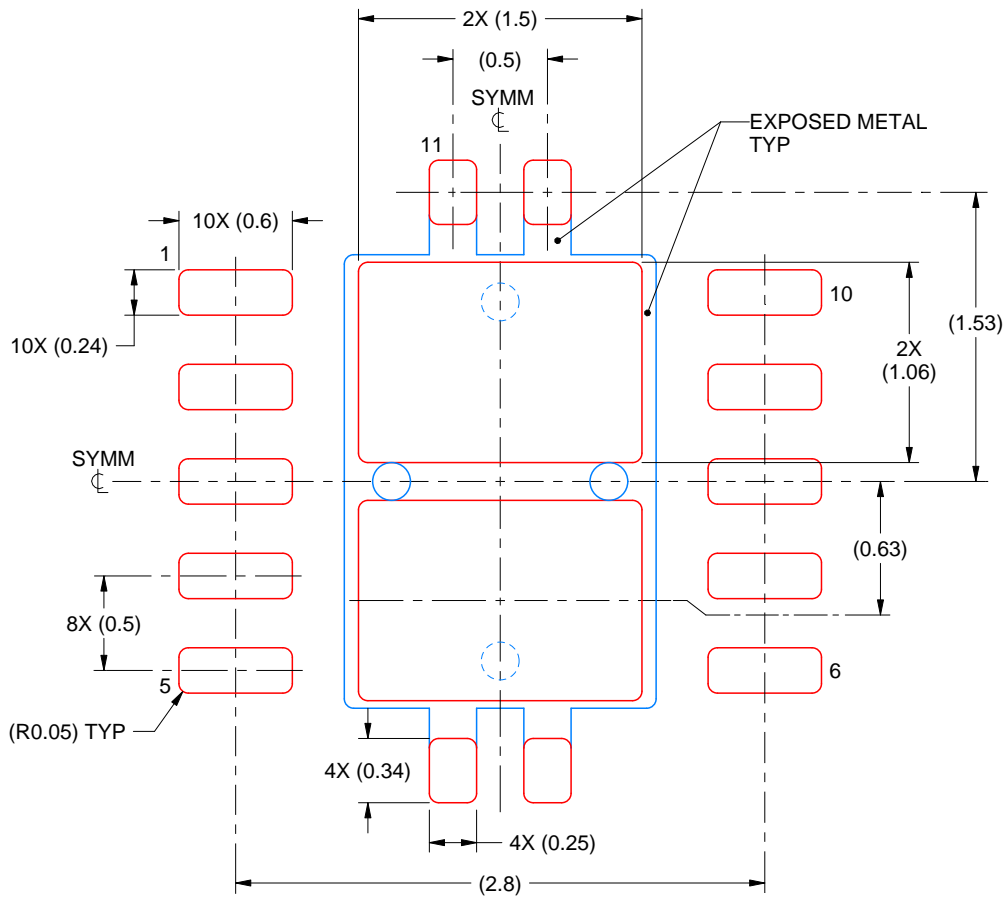

SOLDER PASTE EXAMPLE
BASED ON 0.125 mm THICK STENCIL

EXPOSED PAD 11:
80% PRINTED SOLDER COVERAGE BY AREA
SCALE:25X

4221826/E 03/2026

NOTES: (continued)

7. Laser cutting apertures with trapezoidal walls and rounded corners may offer better paste release. IPC-7525 may have alternate design recommendations.

重要通知和免责声明

TI“按原样”提供技术和可靠性数据（包括数据表）、设计资源（包括参考设计）、应用或其他设计建议、网络工具、安全信息和其他资源，不保证没有瑕疵且不做任何明示或暗示的担保，包括但不限于对适销性、与某特定用途的适用性或不侵犯任何第三方知识产权的暗示担保。

这些资源可供使用 TI 产品进行设计的熟练开发人员使用。您将自行承担以下全部责任：(1) 针对您的应用选择合适的 TI 产品，(2) 设计、验证并测试您的应用，(3) 确保您的应用满足相应标准以及任何其他安全、安保法规或其他要求。

这些资源如有变更，恕不另行通知。TI 授权您仅可将这些资源用于研发本资源所述的 TI 产品的相关应用。严禁以其他方式对这些资源进行复制或展示。您无权使用任何其他 TI 知识产权或任何第三方知识产权。对于因您对这些资源的使用而对 TI 及其代表造成的任何索赔、损害、成本、损失和债务，您将全额赔偿，TI 对此概不负责。

TI 提供的产品受 [TI 销售条款](#)、[TI 通用质量指南](#) 或 [ti.com](#) 上其他适用条款或 TI 产品随附的其他适用条款的约束。TI 提供这些资源并不会扩展或以其他方式更改 TI 针对 TI 产品发布的适用的担保或担保免责声明。除非德州仪器 (TI) 明确将某产品指定为定制产品或客户特定产品，否则其产品均为按确定价格收入目录的标准通用器件。

TI 反对并拒绝您可能提出的任何其他或不同的条款。

版权所有 © 2026，德州仪器 (TI) 公司

最后更新日期：2025 年 10 月