

250mA 双路输出有源矩阵有机发光二极管 (AMOLED) 显示屏电源

 查询样品: [TPS65137AS](#)

特性

- **2.5V 至 4.8V** 输入电压范围
- **0.8%** 输出电压精度 $V_{正向}$
- 出色的线路瞬态稳压
- **250mA** 输出电流
- 固定 **4.6V $V_{正向}$** 输出电压
- 数字可编程 $V_{负向}$, **-2.2V 至 -5.2V**
- $V_{负向}$ 的缺省值为 **-4.9V**
- 短路保护
- 热关断
- **3mm × 3mm 10** 引脚四方扁平无引线 (QFN) 封装

说明

TPS65137AS 被设计用于驱动需要正负电压电源轨的 AMOLED 显示屏 (有源矩阵有机发光二极管)。此器件集成了一个具有低压降 (LDO) 后置稳压器的升压转换器和一个适合于电池供电类产品的反相降压-升压转换器。数字控制引脚 (CTRL) 允许用数字步进设定负输出电压。TPS65137AS 使用一个可实现出色线路和负载稳压的全新技术。需要使用此技术来避免手机发送阶段产生的输入电压干扰对 AMOLED 显示屏造成的影响。

应用范围

- 有源矩阵 **OLED**

典型应用

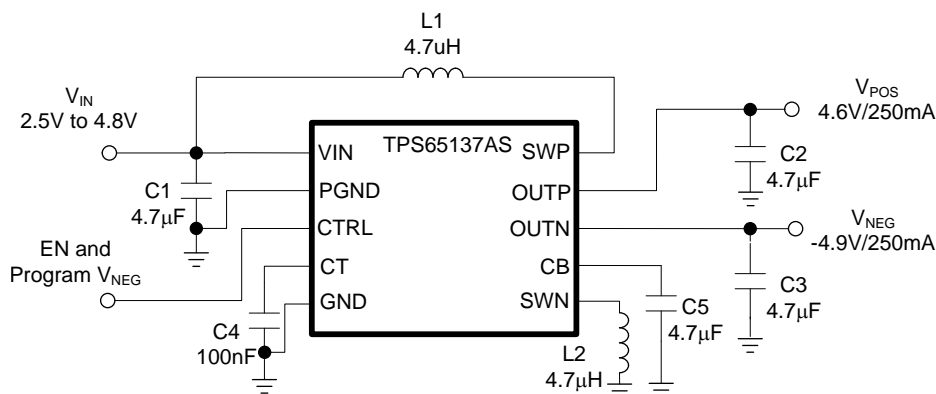

Please be aware that an important notice concerning availability, standard warranty, and use in critical applications of Texas Instruments semiconductor products and disclaimers thereto appears at the end of this data sheet.



This integrated circuit can be damaged by ESD. Texas Instruments recommends that all integrated circuits be handled with appropriate precautions. Failure to observe proper handling and installation procedures can cause damage.

ESD damage can range from subtle performance degradation to complete device failure. Precision integrated circuits may be more susceptible to damage because very small parametric changes could cause the device not to meet its published specifications.

ORDERING INFORMATION^{(1) (2)}

T _A	PACKAGE ⁽²⁾	ORDERABLE PART NUMBER	TOP-SIDE MARKING
-40°C to 85°C	10-Pin 3x3 QFN	TPS65137ASDSCR	PPGC

- (1) For the most current package and ordering information, see the Package Option Addendum at the end of this document, or see the TI web site at www.ti.com.
- (2) Package drawings, thermal data, and symbolization are available at www.ti.com/packaging.

ABSOLUTE MAXIMUM RATINGS

over operating free-air temperature range (unless otherwise noted)⁽¹⁾

		VALUE		UNIT
		MIN	MAX	
Pin Voltage ⁽²⁾	PVIN, SWP, OUTP, CTRL, VL, CB		5.5	V
	OUTN		-6.5	V
	SWN	-6.5	5.5	V
	CT		3.6	V
ESD rating	HBM		2	kV
	MM		200	V
	CDM		500	V
T _J	Operating junction temperature range	-40	50	°C
T _A	Operating ambient temperature range	-40	85	°C
T _{stg}	Storage temperature range	-65	150	°C

- (1) Stresses beyond those listed under *absolute maximum ratings* may cause permanent damage to the device. These are stress ratings only, and functional operation of the device at these or any other conditions beyond those indicated under *recommended operating conditions* is not implied. Exposure to absolute-maximum-rated conditions for extended periods may affect device reliability.
- (2) With respect to GND pin.

THERMAL INFORMATION

THERMAL METRIC ⁽¹⁾	TPS65137AS		UNITS
	DSC		
	10		
θ _{JA} Junction-to-ambient thermal resistance	56.5		°C/W
θ _{JB} Junction-to-board thermal resistance	25.2		
ψ _{JT} Junction-to-top characterization parameter	1.0		
ψ _{JB} Junction-to-board characterization parameter	17.9		

- (1) For more information about traditional and new thermal metrics, see the IC Package Thermal Metrics application report, [SPRA953](#).

RECOMMENDED OPERATING CONDITIONS

		MIN	TYP	MAX	UNIT
V _{IN}	Input supply voltage range	2.5	3.7	4.8	V
T _A	Operating ambient temperature	-40	25	85	°C
T _J	Operating junction temperature	-40	85	125	°C

ELECTRICAL CHARACTERISTICS

$V_{IN} = 3.7V$, $CTRL = V_{IN}$, $V_{POS} = 4.6V$, $V_{NEG} = -4.9V$, $T_A = -40^{\circ}C$ to $85^{\circ}C$, typical values are at $T_A = 25^{\circ}C$ (unless otherwise noted)

PARAMETER		TEST CONDITIONS	MIN	TYP	MAX	UNIT
SUPPLY CURRENT AND THERMAL PROTECTION						
V_{IN}	Input voltage range		2.5		4.8	V
I_Q	Operating quiescent current into V_{IN}	V_{POS} and V_{NEG} have no load ⁽¹⁾		16		mA
I_{SD}	Shutdown current into V_{IN}	$CTRL = GND$		0.1		μA
V_{UVLO}	Under-voltage lockout threshold	V_{IN} falling			2.0	V
		V_{IN} rising			2.3	
	Thermal shutdown			145		$^{\circ}C$
OUTPUT V_{POS}						
V_{POS}	Positive output voltage regulation		-0.8%	4.6	0.8%	V
$r_{DS(ON)}$	SWP MOSFET on-resistance	$I_{SWP} = 200$ mA		200		$m\Omega$
	SWP MOSFET rectifier on-resistance	$I_{SWP} = 200$ mA		250		$m\Omega$
f_{SWP}	SWP Switching frequency	$I_{POS} = 0$ mA		1.6		MHz
I_{SWP}	SWP switch current limit	Inductor valley current	0.9	1.2		A
$V_{P(SCP)}$	Short circuit threshold in operation	V_{POS} falling		3.7		V
I_{PLEAK}	Leakage current into V_{POS}	$CTRL = GND$		2	5	μA
V_{DROP}	LDO drop out voltage	$I_{POS} = 100$ mA		400		mV
	Line regulation	$I_{POS} = 0$ mA		0		%/V
	Load regulation	$I_{POS} = 0$ to 250 mA		0.28		%/A
OUTPUT V_{NEG}						
V_{NEG}	Negative output voltage default			-4.9		V
	Negative output voltage range		-2.2		-5.2	V
	Negative output voltage regulation	$-5.2 \leq V_{NEG} \leq -4.2$	-1%		1%	
		$-4.2 < V_{NEG} \leq -2.2$	-1.5%		1.5%	
$r_{DS(ON)}$	SWN MOSFET on-resistance	$I_{SWN} = 200$ mA		200		$m\Omega$
	SWN MOSFET rectifier on-resistance	$I_{SWN} = 200$ mA		300		
f_{SWN}	SWN switching frequency	$I_{NEG} = 100$ mA		1.7		MHz
I_{SWN}	SWN switch current limit	$V_{IN} = 2.9$ V	1.2	2.2		A
$V_{N(SCP)}$	Short circuit threshold in operation	Voltage drop from programmed V_{NEG}		420		mV
	Short circuit threshold in start-up		0.18	0.21	0.24	V
$t_{N(SCP)}$	Short circuit detection time in start-up			10		ms
I_{NLEAK}	Leakage current out of V_{NEG}	$CTRL = GND$		2	5	μA
$R_{N(PD)}$	V_{NEG} Pull down resistor before start up	$I_{NEG} = 1$ mA		300		Ω
	Line regulation			0		%/V
	Load regulation	$I_{NEG} = 0$ to 250 mA		0.28		%/A
CTRL INTERFACE						
V_H	Logic high-level voltage		1.2			V
V_L	Logic low-level voltage				0.4	V
R	Pull down resistor		150	400	860	k Ω
t_{INIT}	Initialization time			300	400	μs
t_{OFF}	Shutdown time period		30		80	μs
t_{HIGH}	Pulse high level time period		2	10	25	μs
t_{LOW}	Pulse low level time period		2	10	25	μs
t_{STORE}	Data storage/accept time period		30		80	μs
R_T	C_T pin output impedance		150	325	500	k Ω

(1) With inductor DFE252012C 4.7 μH from TOKO

DEVICE INFORMATION

**10 PIN TQFN PACKAGE
(TOP VIEW)**

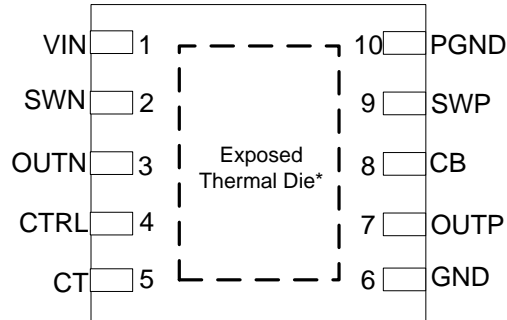

Pin Functions

PIN		I/O ⁽¹⁾	DESCRIPTION
NO.	NAME		
1	VIN	I	Input supply for the negative buck-boost converter generating V_{NEG}
2	SWN	I	Switch pin of the negative buck-boost converter
3	OUTN	O	Output of negative buck-boost converter
4	CTRL	I	Combined enable and V_{NEG} programming pin.
5	CT	O	Sets the settling time for the voltage on V_{NEG} when programmed to a new value
6	GND	G	Analog ground
7	OUTP	O	Output of the boost converter
8	CB	O	Internal boost converter bypass capacitor
9	SWP	I	Switch pin of the boost converter
10	PGND	G	Power ground of boost converter
Exposed thermal die		G	Connect this pad to analog GND.

(1) G = Ground, I = Input, O = Output

FUNCTIONAL BLOCK DIAGRAM

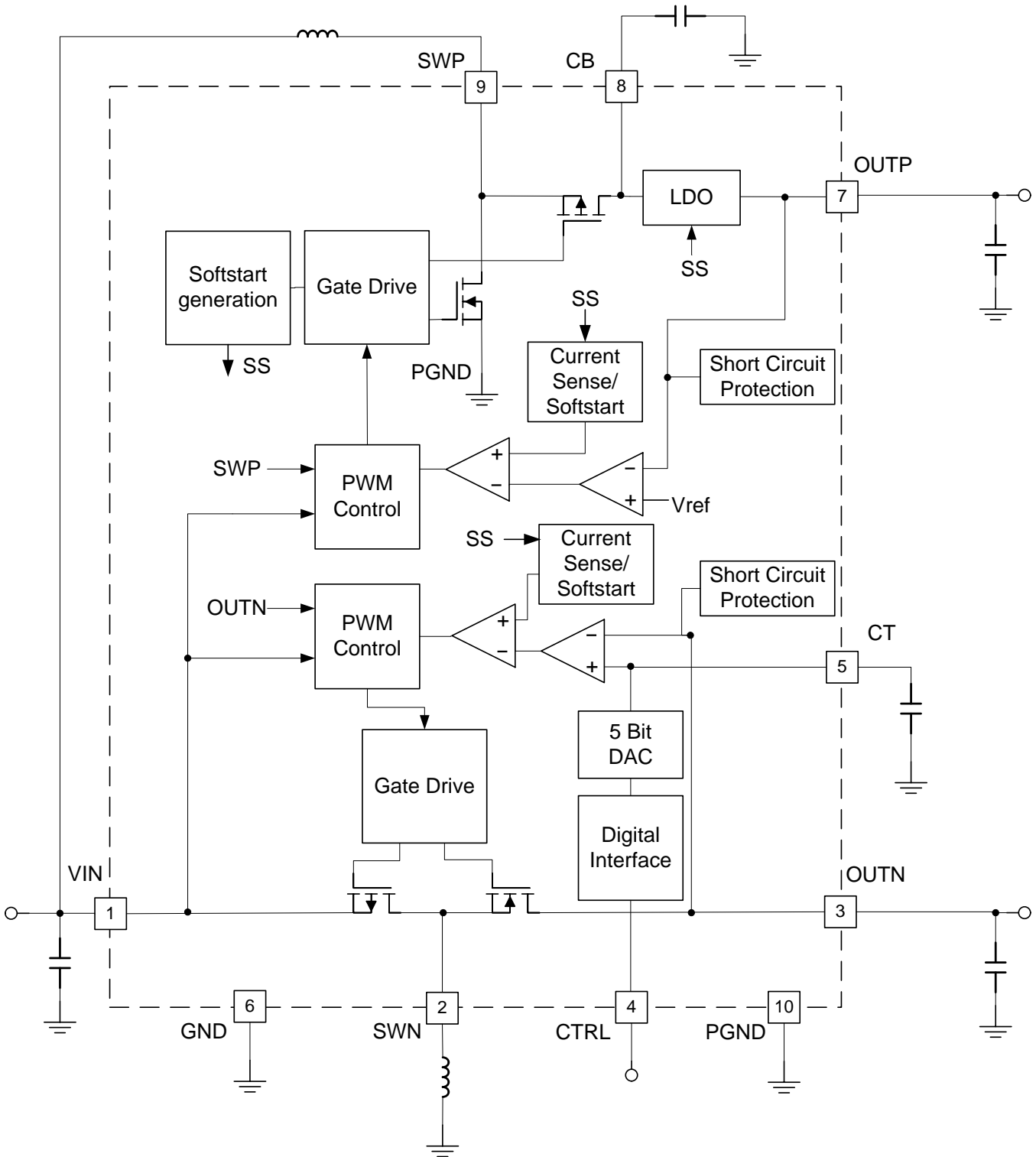

TYPICAL CHARACTERISTICS

TABLE OF GRAPHS

		FIGURE
Efficiency versus Output current (Output current is from V_{POS} to V_{NEG})	$V_{POS} = 4.6\text{ V}$, $V_{NEG} = -4.9\text{ V}$	Figure 1
Startup		Figure 2
Switch pins and output waveforms (Output current is from V_{POS} to V_{NEG})	$I_{OUT} = 100\text{ mA}$, Boost and BuckBoost	Figure 3
	$I_{OUT} = 250\text{ mA}$, Boost and BuckBoost	Figure 4
	$I_{OUT} = 250\text{ mA}$, Boost	Figure 5
	$I_{OUT} = 250\text{ mA}$, BuckBoost	Figure 6

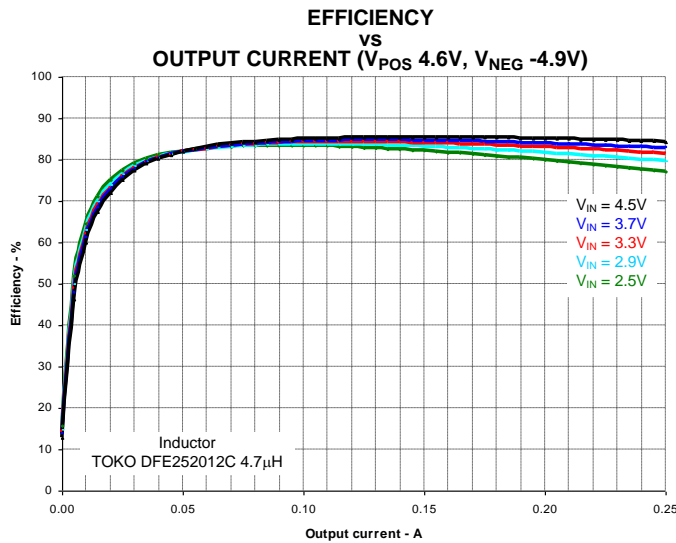

Figure 1.

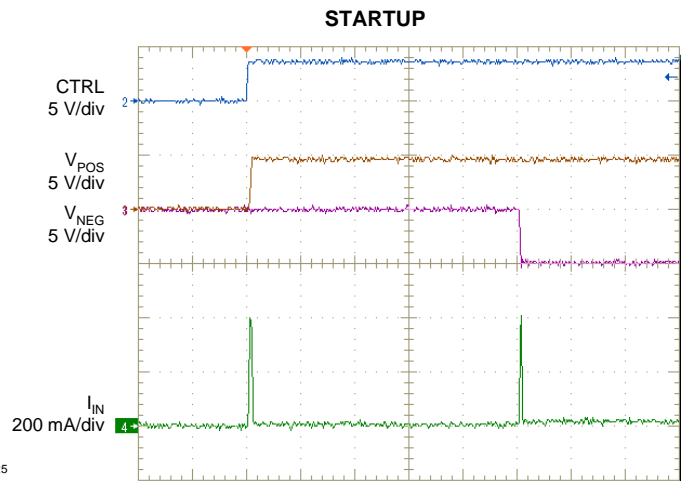

Figure 2.

SWITCH PINS AND OUTPUTS BOOST AND BUCKBOOST, $I_{OUT} 100\text{mA}$

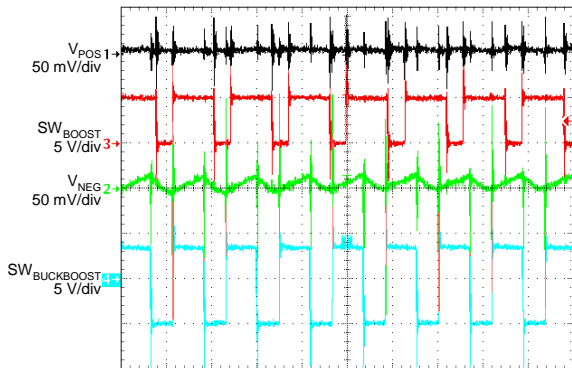

Figure 3.

SWITCH PINS AND OUTPUTS BOOST AND BUCKBOOST, $I_{OUT} 250\text{mA}$

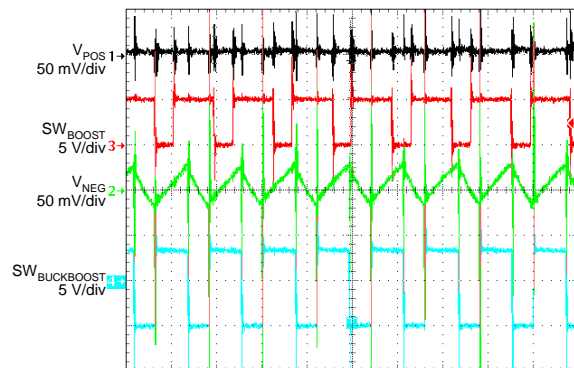
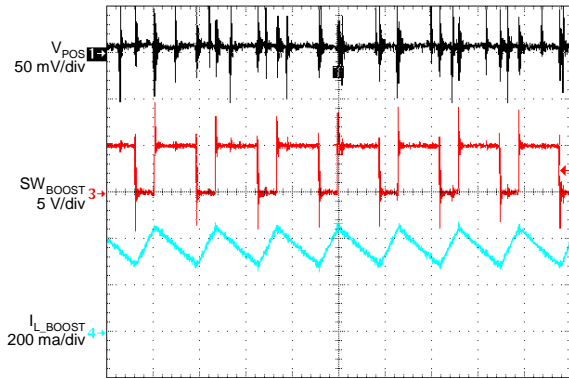

Figure 4.

SWITCH PINS AND OUTPUTS BOOST, I_{OUT} 250mA



500 ns/div

Figure 5.

SWITCH PINS AND OUTPUTS BUCKBOOST, I_{OUT} 250mA

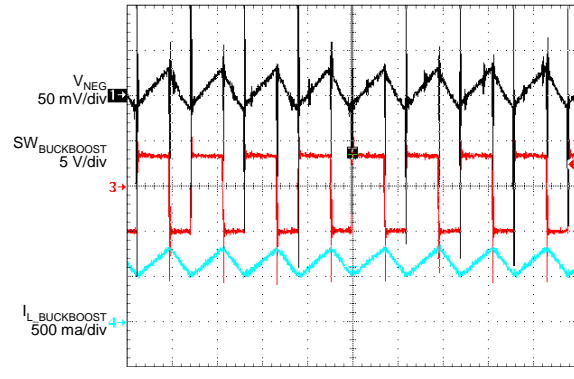

500 ns/div

Figure 6.

APPLICATION FOR TYPICAL CHARACTERISTICS

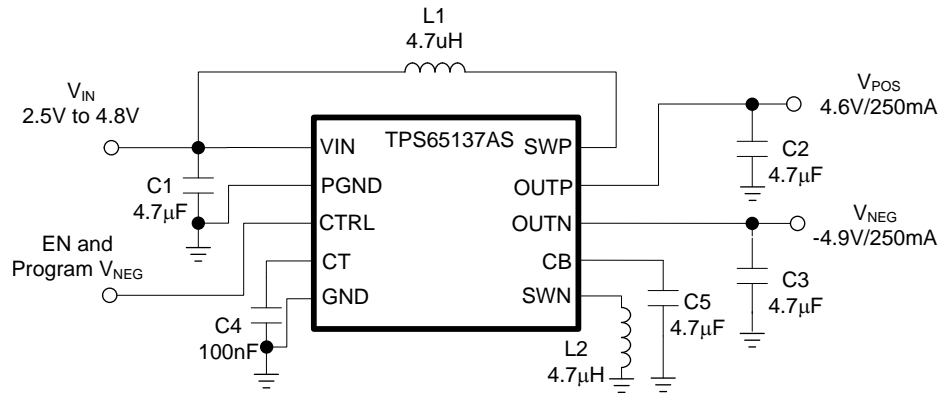

Figure 7. Application for Typical Characteristics

Table 1. Bill of Materials for Typical Characteristics

	Value	Part Number	Manufacturer
C1, C2, C3, C5	4.7 µF, X5R	GRM21BR61C475KA88	Murata
C4	100 nF, X7R	GRM21BR71E104KA01	Murata
L1, L2	4.7 µH	DFE252012C 4.7 µH	TOKO

DETAILED DESCRIPTION

The TPS65137AS consists of a boost converter using an LDO as post regulator and an inverting buck-boost converter. The positive output is fixed at 4.6V. The negative output is programmable by a digital interface in the range of -2.2V to -5.2V , the default is -4.9V . The transition time of the negative output is adjustable by the CT pin capacitor.

SOFT START and START-UP SEQUENCE

The device has a soft start to limit the in-rush current. When the device is enabled by the CTRL pin going HIGH, the boost converter starts with a reduced switch current limit. 8ms after CTRL going HIGH, the buck-boost converter starts with the default value of -4.9V . The typical start-up sequence is shown in Figure 8.

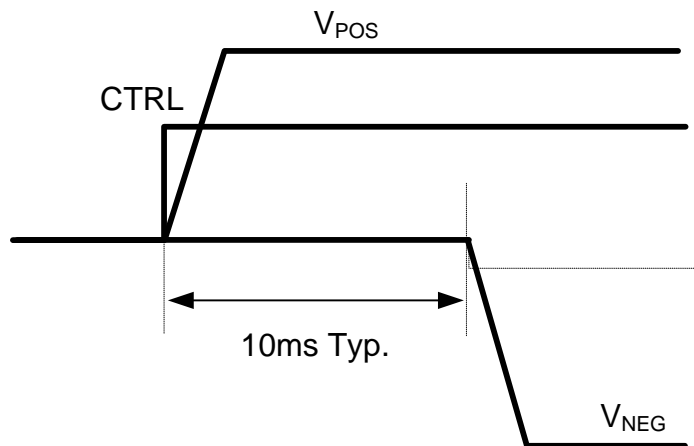

Figure 8. Start-up Sequence

SHORT CIRCUIT PROTECTION

The device is protected against short circuits of the outputs to ground and short circuit of the outputs to each other. During normal operation, an error condition is detected if V_{POS} falls below 3.7V for more than 3ms or V_{NEG} gets above 420mV above the programmed value for more than 3ms. In either case, the device goes into shutdown and this state is latched. The input and the outputs are disconnected. To resume normal operation, V_{IN} has to cycle below UVLO or CTRL has to toggle LOW and HIGH.

During start up, an error condition is detected in the following cases:

- V_{POS} is not in regulation 10ms after CTRL goes HIGH.
- V_{NEG} is higher than threshold level 10ms after CTRL goes HIGH.
- V_{NEG} is not in regulation 20ms after CTRL goes HIGH.

In the above cases, the device goes into shutdown and this state is latched. The input and the outputs are disconnected. To resume normal operation, V_{IN} has to cycle below UVLO or CTRL has to toggle LOW and HIGH.

ENABLE (CTRL PIN)

The CTRL pin serves two functions. One is to enable and disable the device the other is the output voltage programming of the device. If the digital interface is not required the CTRL pin can be used as a standard enable pin for the device and the device will come up with its default value on V_{NEG} of -4.9V . When CTRL is pulled high, the device is enabled. The device is shut down with CTRL low.

DIGITAL INTERFACE (CTRL)

The digital interface allows programming the negative output voltage V_{NEG} in digital steps. If the digital output voltage setting is not required then the CTRL pin can also be used as a standard enable pin.

The digital output voltage programming of V_{NEG} is implemented by a simple digital interface with the timing shown in Figure 9.

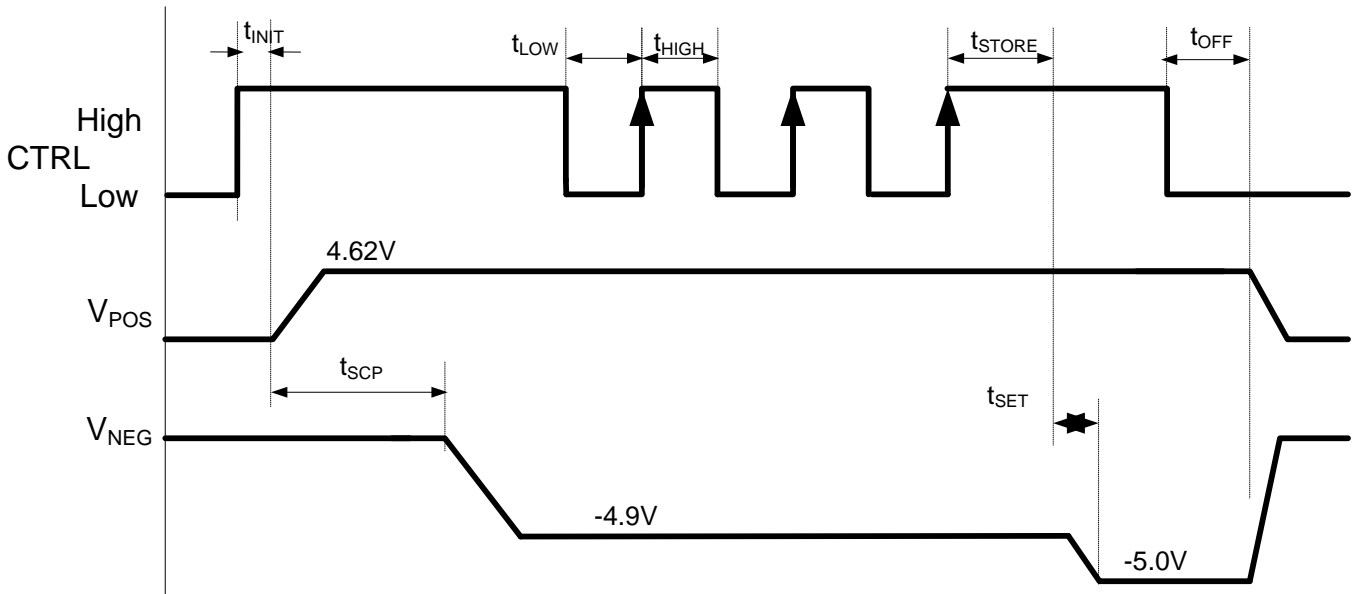

Figure 9. Digital Interface Using CTRL

Once CTRL is pulled high the device will come up with its default voltage of $-4.9V$. The device has a 6-bit DAC implemented with the corresponding output voltages as given in the table below. The interface counts now the rising edges applied to the CTRL pin once the device is enabled. For the example above, V_{NEG} is programmed to $-5.0V$ since 3 rising edges are detected. Other output voltages can be programmed according Table 2.

Table 2. Programming Table for V_{NEG}

BIT/RISING EDGES	V_{NEG}	DAC VALUE	BIT/RISING EDGES	V_{NEG}	DAC VALUE
0/ no pulse	$-4.9 V$	00000	16	$-3.7 V$	10000
1	$-5.2 V$	00001	17	$-3.6 V$	10001
2	$-5.1 V$	00010	18	$-3.5 V$	10010
3	$-5.0 V$	00011	19	$-3.4 V$	10011
4	$-4.9 V$	00100	20	$-3.3 V$	10100
5	$-4.8 V$	00101	21	$-3.2 V$	10101
6	$-4.7 V$	00110	22	$-3.1 V$	10110
7	$-4.6 V$	00111	23	$-3.0 V$	10111
8	$-4.5 V$	01000	24	$-2.9 V$	11000
9	$-4.4 V$	01001	25	$-2.8 V$	11001
10	$-4.3 V$	01010	26	$-2.7 V$	11010
11	$-4.2 V$	01011	27	$-2.6 V$	11011
12	$-4.1 V$	01100	28	$-2.5 V$	11100
13	$-4.0 V$	01101	29	$-2.4 V$	11101
14	$-3.9 V$	01110	30	$-2.3 V$	11110
15	$-3.8 V$	01111	31	$-2.2 V$	11111

SETTING TRANSITION TIME t_{set} for V_{NEG} (C_T)

The device allows setting the transition time t_{set} using an external capacitor connected to pin CT. The transition time is the time period required to move V_{NEG} from one voltage level to the next programmed voltage level. The capacitor connected to pin CT does not influence the soft start time t_{ss} of the V_{NEG} default value. When the CT pin is left open then the shortest possible transition time is programmed. When connecting a capacitor to the CT pin then the transition time is given by an R-C time constant. This is given by the output impedance of the CT pin typically 325k Ω and the external capacitance. Within one τ the output voltage V_{NEG} has reached 70% of its programmed value. An example is given when using 100nF for C_T .

$$\tau \approx t_{set70\%} = 325 \text{ k}\Omega \times C_T = 325 \text{ k}\Omega \times 100 \text{ nF} = 32.5 \text{ mS}$$

The output voltage is almost at its programmed value after 3τ .

PCB LAYOUT

Figure 10 and Figure 11 show an example of a PCB layout design.

1. Place the input capacitor on VIN and the output capacitor on OUTN as close as possible to the device.
Use short and wide traces to connect the input capacitor to VIN and the output capacitor to OUTN.
2. Place the output capacitor on OOTP and the capacitor on CB as close as possible to the device.
Use short and wide traces to connect the output capacitor to OOTP.
3. Connect the ground of the CT capacitor to the GND pin, pin 6, directly.
4. Connect the input ground and the output ground on the same board layer, not through vias.

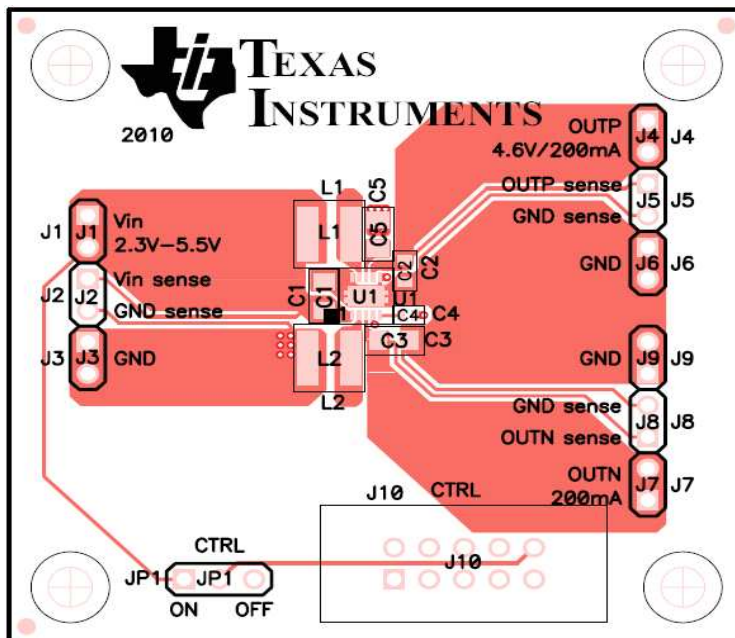

Figure 10. Example of PCB Layout Design (Top layer)

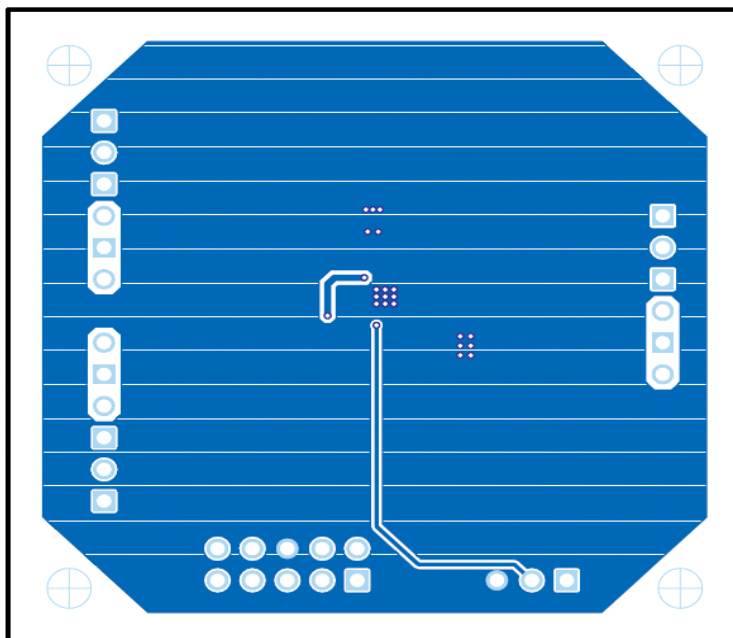

Figure 11. Example of PCB Layout Design (Bottom layer)

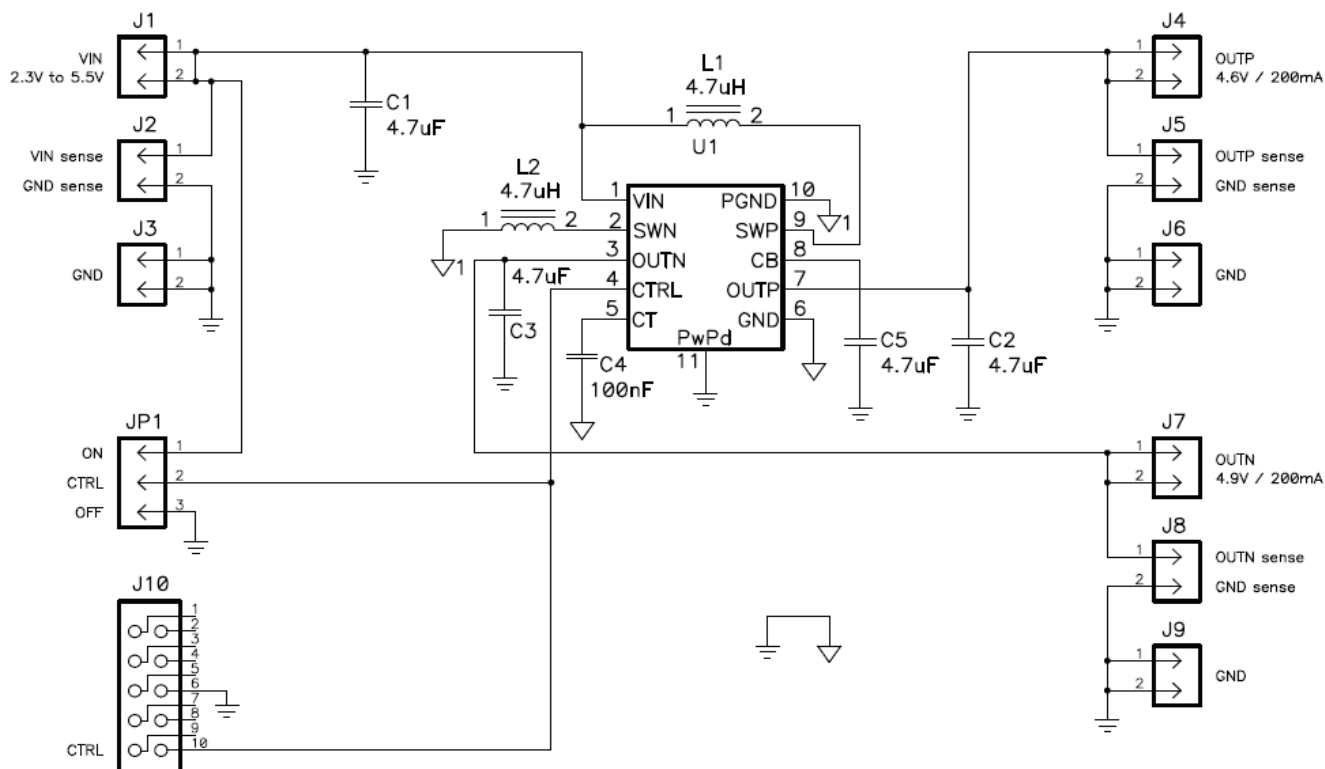

Figure 12. Schematic for the Example of PCB Layout Design

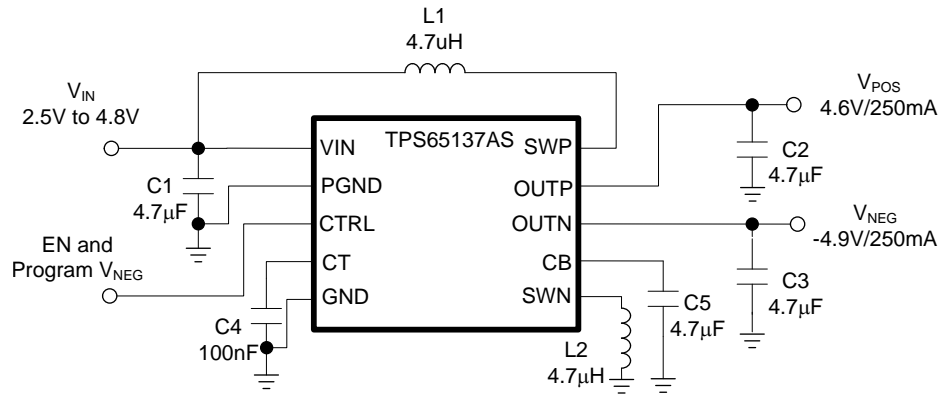

Figure 13. Typical Application Circuit

PACKAGING INFORMATION

Orderable Device	Status (1)	Package Type	Package Drawing	Pins	Package Qty	Eco Plan (2)	Lead finish/ Ball material (6)	MSL Peak Temp (3)	Op Temp (°C)	Device Marking (4/5)	Samples
TPS65137ASDSCR	ACTIVE	WSON	DSC	10	3000	RoHS & Green	NIPDAU	Level-2-260C-1 YEAR	-40 to 85	PPGC	Samples

(1) The marketing status values are defined as follows:

ACTIVE: Product device recommended for new designs.

LIFEBUY: TI has announced that the device will be discontinued, and a lifetime-buy period is in effect.

NRND: Not recommended for new designs. Device is in production to support existing customers, but TI does not recommend using this part in a new design.

PREVIEW: Device has been announced but is not in production. Samples may or may not be available.

OBSOLETE: TI has discontinued the production of the device.

(2) **RoHS:** TI defines "RoHS" to mean semiconductor products that are compliant with the current EU RoHS requirements for all 10 RoHS substances, including the requirement that RoHS substance do not exceed 0.1% by weight in homogeneous materials. Where designed to be soldered at high temperatures, "RoHS" products are suitable for use in specified lead-free processes. TI may reference these types of products as "Pb-Free".

RoHS Exempt: TI defines "RoHS Exempt" to mean products that contain lead but are compliant with EU RoHS pursuant to a specific EU RoHS exemption.

Green: TI defines "Green" to mean the content of Chlorine (Cl) and Bromine (Br) based flame retardants meet JS709B low halogen requirements of <=1000ppm threshold. Antimony trioxide based flame retardants must also meet the <=1000ppm threshold requirement.

(3) MSL, Peak Temp. - The Moisture Sensitivity Level rating according to the JEDEC industry standard classifications, and peak solder temperature.

(4) There may be additional marking, which relates to the logo, the lot trace code information, or the environmental category on the device.

(5) Multiple Device Markings will be inside parentheses. Only one Device Marking contained in parentheses and separated by a "-" will appear on a device. If a line is indented then it is a continuation of the previous line and the two combined represent the entire Device Marking for that device.

(6) Lead finish/Ball material - Orderable Devices may have multiple material finish options. Finish options are separated by a vertical ruled line. Lead finish/Ball material values may wrap to two lines if the finish value exceeds the maximum column width.

Important Information and Disclaimer:The information provided on this page represents TI's knowledge and belief as of the date that it is provided. TI bases its knowledge and belief on information provided by third parties, and makes no representation or warranty as to the accuracy of such information. Efforts are underway to better integrate information from third parties. TI has taken and continues to take reasonable steps to provide representative and accurate information but may not have conducted destructive testing or chemical analysis on incoming materials and chemicals. TI and TI suppliers consider certain information to be proprietary, and thus CAS numbers and other limited information may not be available for release.

In no event shall TI's liability arising out of such information exceed the total purchase price of the TI part(s) at issue in this document sold by TI to Customer on an annual basis.

TAPE AND REEL INFORMATION

QUADRANT ASSIGNMENTS FOR PIN 1 ORIENTATION IN TAPE

*All dimensions are nominal

Device	Package Type	Package Drawing	Pins	SPQ	Reel Diameter (mm)	Reel Width W1 (mm)	A0 (mm)	B0 (mm)	K0 (mm)	P1 (mm)	W (mm)	Pin1 Quadrant
TPS65137ASDSCR	WSO	DSC	10	3000	330.0	12.4	3.3	3.3	1.1	8.0	12.0	Q2

TAPE AND REEL BOX DIMENSIONS

*All dimensions are nominal

Device	Package Type	Package Drawing	Pins	SPQ	Length (mm)	Width (mm)	Height (mm)
TPS65137ASDSCR	WSON	DSC	10	3000	552.0	346.0	36.0

TUBE

*All dimensions are nominal

Device	Package Name	Package Type	Pins	SPQ	L (mm)	W (mm)	T (μm)	B (mm)
TPS65137ASDSCR	DSC	WSON	10	3000	381	4.83	2286	0

GENERIC PACKAGE VIEW

DSC 10

WSON - 0.8 mm max height

PLASTIC SMALL OUTLINE - NO LEAD

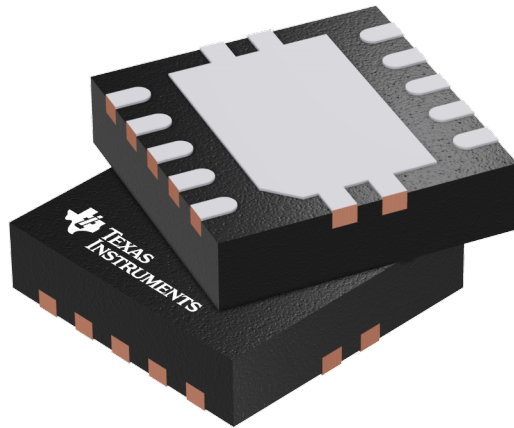

Images above are just a representation of the package family, actual package may vary.
Refer to the product data sheet for package details.

4207383/F

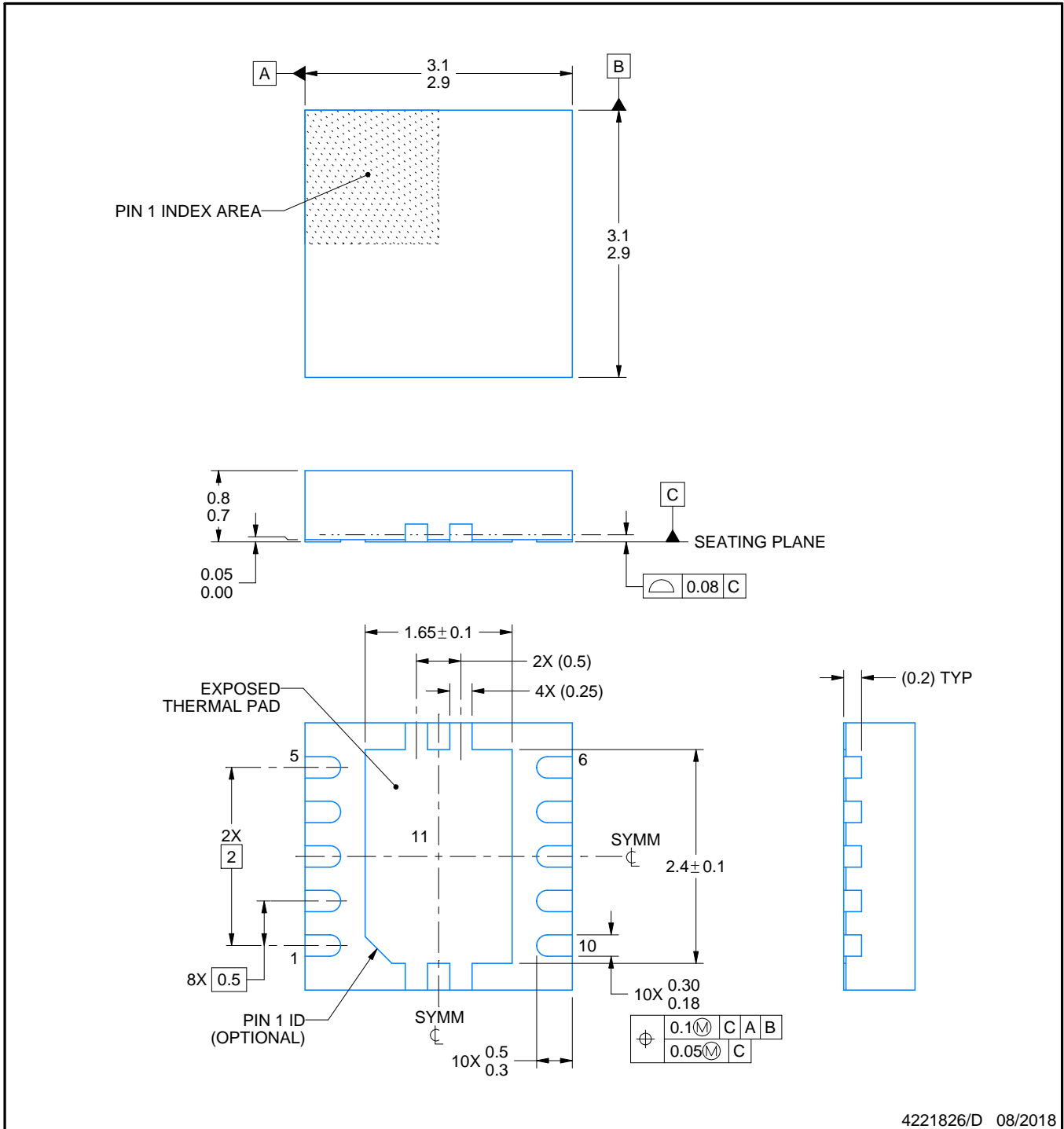
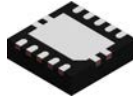

4221826/D 08/2018

NOTES:

1. All linear dimensions are in millimeters. Any dimensions in parenthesis are for reference only. Dimensioning and tolerancing per ASME Y14.5M.
2. This drawing is subject to change without notice.
3. The package thermal pad must be soldered to the printed circuit board for optimal thermal and mechanical performance.

EXAMPLE BOARD LAYOUT

DSC0010J

WSON - 0.8 mm max height

PLASTIC SMALL OUTLINE - NO LEAD



LAND PATTERN EXAMPLE
EXPOSED METAL SHOWN
SCALE:20X

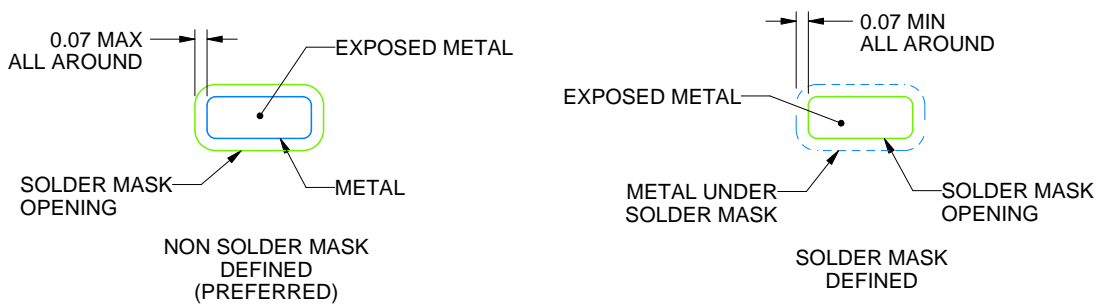

SOLDER MASK DETAILS

4221826/D 08/2018

NOTES: (continued)

4. This package is designed to be soldered to a thermal pad on the board. For more information, see Texas Instruments literature number SLUA271 (www.ti.com/lit/sluea271).
5. Vias are optional depending on application, refer to device data sheet. If any vias are implemented, refer to their locations shown on this view. It is recommended that vias under paste be filled, plugged or tented.

EXAMPLE STENCIL DESIGN

DSC0010J

WSON - 0.8 mm max height

PLASTIC SMALL OUTLINE - NO LEAD



SOLDER PASTE EXAMPLE
BASED ON 0.125 mm THICK STENCIL

EXPOSED PAD 11:
80% PRINTED SOLDER COVERAGE BY AREA
SCALE:25X

4221826/D 08/2018

NOTES: (continued)

6. Laser cutting apertures with trapezoidal walls and rounded corners may offer better paste release. IPC-7525 may have alternate design recommendations.

重要声明和免责声明

TI“按原样”提供技术和可靠性数据（包括数据表）、设计资源（包括参考设计）、应用或其他设计建议、网络工具、安全信息和其他资源，不保证没有瑕疵且不做任何明示或暗示的担保，包括但不限于对适销性、某特定用途方面的适用性或不侵犯任何第三方知识产权的暗示担保。

这些资源可供使用 TI 产品进行设计的熟练开发人员使用。您将自行承担以下全部责任：(1) 针对您的应用选择合适的 TI 产品，(2) 设计、验证并测试您的应用，(3) 确保您的应用满足相应标准以及任何其他功能安全、信息安全、监管或其他要求。

这些资源如有变更，恕不另行通知。TI 授权您仅可将这些资源用于研发本资源所述的 TI 产品的应用。严禁对这些资源进行其他复制或展示。您无权使用任何其他 TI 知识产权或任何第三方知识产权。您应全额赔偿因在这些资源的使用中对 TI 及其代表造成的任何索赔、损害、成本、损失和债务，TI 对此概不负责。

TI 提供的产品受 [TI 的销售条款](#) 或 [ti.com](#) 上其他适用条款/TI 产品随附的其他适用条款的约束。TI 提供这些资源并不会扩展或以其他方式更改 TI 针对 TI 产品发布的适用的担保或担保免责声明。

TI 反对并拒绝您可能提出的任何其他或不同的条款。

邮寄地址：Texas Instruments, Post Office Box 655303, Dallas, Texas 75265

Copyright © 2023，德州仪器 (TI) 公司