

具有减少的接地 (GND) 开关 R_{导通} 和调频 (FM) 功能的自主音频头戴式耳机开关

 查询样品: **TS3A226AE**

特性

- 接地场效应晶体管 (FET) 开关 (典型值 **60mΩ**)
- 耳机类型的自主检测:
3 极或 4 极 (SLEEVE 或 RING2 上有麦克风 (MIC))
- 麦克风线路开关
- 支持通过接地 FET 传输 FM 信号
- 减少卡塔/爆裂噪音
- **VDD** 范围: **2.6V – 4.7V**
- 总谐波失真 (THD) (Mic): 典型值 **0.002%**
- 低流耗: 典型值 **6.5μA**
- **±8kV** 接触放电 (IEC 61000-4-2) 静电放电 (ESD) SLEEVE 和 RING2 引脚的性能

应用范围

- 移动电话 / 平板个人电脑
- 笔记本电脑/超级本计算机

说明

TS3A226AE 是一款音频头戴式耳机开关, 此开关可检测 3 极或 4 极 3.5mm 配件。对于带有麦克风的 4 极配件, TS3A226AE 还能够检测麦克风位置, 并自动发送麦克风以及接地信号。此接地信号通过一对低阻抗接地 FET (典型值 **60mΩ**) 发送, 所以大大降低了对音频串扰性能的影响。自主检测特性使得最终用户能够将具有不同音频极配置的配件插入移动器件中, 并使它们运转正常, 而无需增加软件控制, 并且不会增加复杂度。器件的接地 FET 被设计成可让 FM 信号通过, 这样的话, 可将头戴式耳机的接地线用作移动音频应用中的 FM 天线。

TS3A226AE 采用 1.2mm x 1.2mm 晶圆级芯片 (WCSP) 封装, 这使得它适合在移动应用中使用。



图 1. 典型应用图

订购信息

要获得最新的封装和订货信息, 请参阅本文档末尾的封装选项附录, 或者浏览 TI 网站 www.ti.com 进行查询。

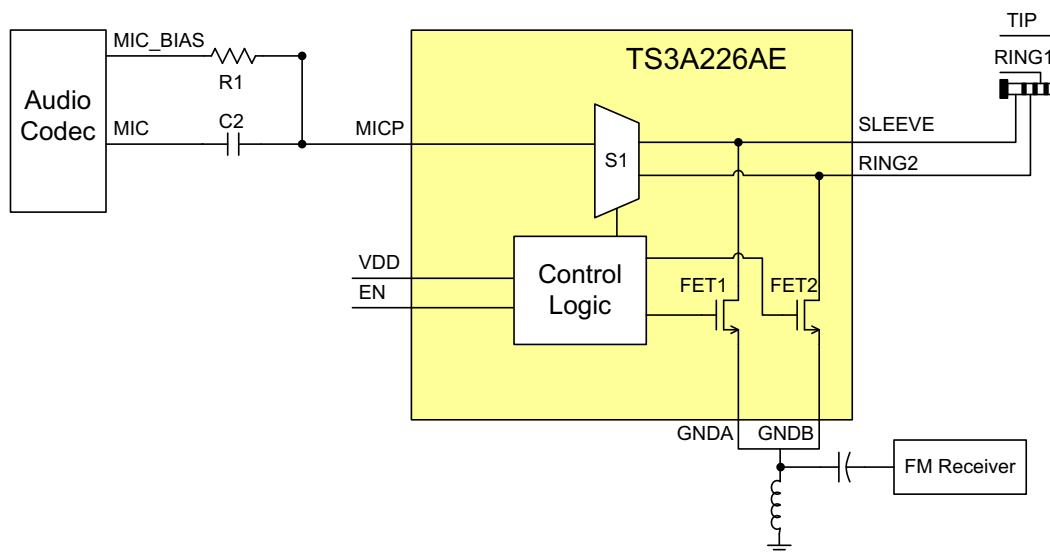

Please be aware that an important notice concerning availability, standard warranty, and use in critical applications of Texas Instruments semiconductor products and disclaimers thereto appears at the end of this data sheet.

TS3A226AE

ZHCSB51A–JUNE 2013–REVISED JULY 2013

www.ti.com.cn

These devices have limited built-in ESD protection. The leads should be shorted together or the device placed in conductive foam during storage or handling to prevent electrostatic damage to the MOS gates.

PACKAGE; YFF-WCSP

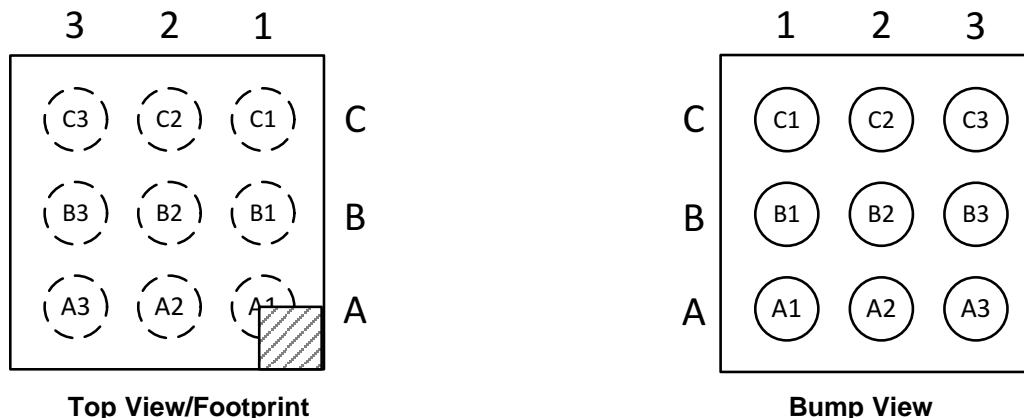

Die Size: 1.2mm x1.2mm
 Bump Size: 0.25mm
 Bump Pitch: 0.4mm

TS3A226AE Pin Mapping (Top View)

	3	2	1
C	GND	TIP	EN
B	SLEEVE	GNDA	MICp
A	RING2	GNDB	VDD

PIN FUNCTIONS

NUMBER	PIN		DESCRIPTION
	NAME	TYPE	
A1	VDD	Supply	Power supply for the chip.
A2	GNDB	Ground	FET2 ground reference.
A3	RING2	I/O	Connected to the RING2 segment of the jack. The pin will be routed automatically by TS3A226AE to either MICp or GNDB depending on the type of accessory.
B1	MICp	I/O	Microphone signal connection to codec. Microphone bias should be fed into this pin.
B2	GNDA	Ground	FET1 ground reference.
B3	SLEEVE	I/O	Connected to the SLEEVE segment of the jack. The pin will be routed automatically by TS3A226AE to either MICp or GNDA depending on the type of accessory.
C1	EN	Input	A rising edge triggers the detection sequence. This pin can be connected to the headset jack to allow automatic pull-up to supply after headset insertion.
C2	TIP	I/O	Connected to the TIP segment of the headphone jack.
C3	GND	Ground	Chip ground reference.

S1 MUX DETAIL

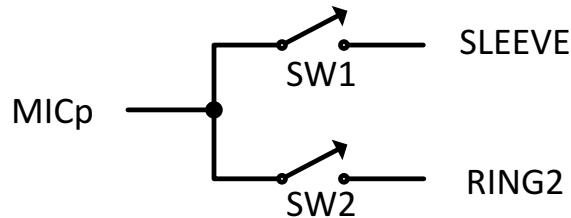

Figure 2. S1 Mux Detail

FUNCTIONAL TABLES: INTERNAL SWITCHES

EN	Accessory Type	Accessory Configuration	SW1	SW2	FET1	FET2
0	N/A	—	High Z	High Z	High Z	High Z
1	TRS 3-pole Headphone or Speaker	TIP = Audio Left Ring = Audio Right Sleeve = Ground	On	On	On	On
1	TRRS 4-pole Headphone	TIP = Audio Left Ring1 = Audio Right Ring2 = Ground Sleeve = Microphone	On	High Z	High Z	On
1	TRRS 4-pole Headphone	TIP = Audio Left Ring1 = Audio Right Ring2 = Microphone Sleeve = Ground	High Z	On	On	High Z
1	N/A	—	On	On	On	On

ABSOLUTE MAXIMUM RATINGS

over operating free-air temperature range (unless otherwise noted)⁽¹⁾

		VALUE	UNIT
V _I	Voltage range on VDD ⁽²⁾	-0.3 to 5	V
	Voltage range on EN, MICP, RING2, SLEEVE, TIP ⁽²⁾	-0.3 to V _{DD} +0.5	V
T _A	Operating ambient temperature range ⁽³⁾	-40 to 85	°C
T _{J (MAX)}	Maximum operating junction temperature	125	°C
T _{stg}	Storage temperature range	-65 to 150	°C
ESD rating	Charge device model (JEDEC 22 C101)	500	V
	Human body model (JEDEC 22 A114)	2	kV
	Contact discharge on RING2, SLEEVE, TIP (IEC 61000-4-2)	8	kV

- (1) Stresses beyond those listed under absolute maximum ratings may cause permanent damage to the device. These are stress ratings only, and functional operation of the device at these or any other conditions beyond those indicated under recommended operating conditions is not implied. Exposure to absolute-maximum-rated conditions for extended periods may affect device reliability.
- (2) All voltage values are with respect to network ground terminal.
- (3) In applications where high power dissipation and/or poor package thermal resistance is present, the maximum ambient temperature may have to be derated. Maximum ambient temperature [T_{A(max)}] is dependent on the maximum operating junction temperature [T_{J(max)}], the maximum power dissipation of the device in the application [P_{D(max)}], and the junction-to-ambient thermal resistance of the part/package in the application (θ_{JA}), as given by the following equation: T_{A(max)} = T_{J(max)} - (θ_{JA} × P_{D(max)})

RECOMMENDED OPERATING CONDITIONS

over operating free-air temperature range (unless otherwise noted)

		MIN	MAX	UNIT	
V _{DD}	Supply voltage range	2.6	4.5	V	
V _{IO}	Input/Output voltage range (EN, MICP, RING2, SLEEVE, TIP)	0	V _{DD}	V	
V _{IO(TIP)}	Input/Output voltage range for TIP	-2.0	V _{DD}	V	
V _{IH}	Input Logic High for EN	V _{DD} = 2.6 V	1.16	V _{DD}	V
		V _{DD} = 3.3 V	1.24	V _{DD}	
		V _{DD} = 4.5 V	1.48	V _{DD}	
V _{IL}	Input Logic Low for EN	V _{DD} = 2.6 V	0	0.19	V
		V _{DD} = 3.3 V	0	0.3	
		V _{DD} = 4.5 V	0	0.5	
T _A	Operating temperature range	-40	85	°C	

KEY ELECTRICAL CHARACTERISTICS

 Unless otherwise noted the specification applies over the V_{DD} range and operating junction temperature -40°C ≤ T_A ≤ 70°C. Typical values are for V_{DD} = 3.3V and T_J = 25°C.

PARAMETER		TEST CONDITIONS	MIN	TYP	MAX	UNIT
V _{DD}	Input Voltage Range		2.6	3.3	4.5	V
I _{DD}	Quiescent Current	V _{DD} = 4.5 V, V _{MICP} = 1.8 V to V _{DD} , EN=L or EN=H (after detection)		6.5	14	μA
SWITCH RESISTANCE						
R _{F1}	FET1 On Resistance	V _{DD} = 2.6 V, V _{GND} = 0 V, I _{GND} = 10 mA		60	85	mΩ
R _{F2}	FET2 On Resistance			60	85	
R _{SW1}	SW1 On Resistance	V _{DD} = 2.6 V, V _{SLEEVE/RING2} = 0 V to 2.6 V, I _{MIC} = ±10 mA		8.5	10.5	Ω
R _{SW2}	SW2 On Resistance			8.5	10.5	
SWITCH LEAKAGE CURRENT						
I _{OFF-0.1}	FET1 and FET2 off leakage	V _{IN} = 0 V to 2.6 V, V _{OUT} = 0 V, V _{DD} = 4.5 V			1	μA
I _{OFF-10}	SW1, SW2 off leakage				1	
I _{ON-10}	SW1, SW2 on leakage				1	
SWITCH DYNAMIC CHARACTERISTICS						
BW _{F1}	FET1 Bandwidth	V = 60 mV _{PP} , I _{bias} = 10 mA	160	200		MHz
BW _{F2}	FET2 Bandwidth		160	200		
PSR ₂₁₇	Power Supply Rejection, R _L = 50 Ω	V = 200 mV _{PP} , f = 217 Hz		-110		dB
PSR _{1k}		V = 200 mV _{PP} , f = 1 kHz		-100		
PSR _{20k}		V = 200 mV _{PP} , f = 20 kHz		-85		
ISO _{S1}	SLEEVE or RING2 to MICP Isolation	V = 200 mV _{PP} , f = 20 kHz, R _L = 50 Ω		-80		dB
SEP _{S1}	SLEEVE to RING2 Separation	V = 200 mV _{PP} , f = 20 kHz, R _L = 50 Ω (see Figure 5)		-80		dB
THD ₁₀	Total Harmonic Distortion	V = 10 mV _{PP} , f = 20-20 kHz, R _S = 600 Ω		0.01%		
THD ₂₀₀		V = 200 mV _{PP} , f = 20-20 kHz, R _S = 600 Ω		0.002%		
TIMING CHARACTERISTICS						
t _{dect}	Total detection time	From EN=H to S1 switch(es) closing		180		ms

TYPICAL CHARACTERISTICS

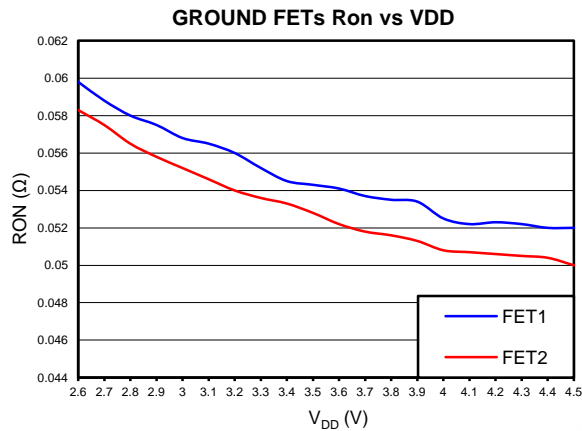

Figure 3.

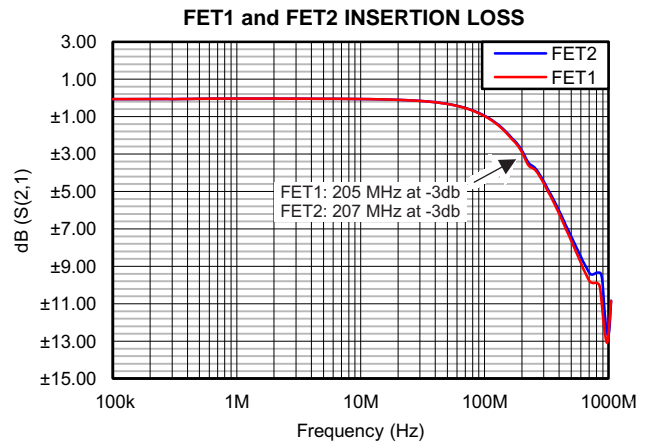

Figure 4.

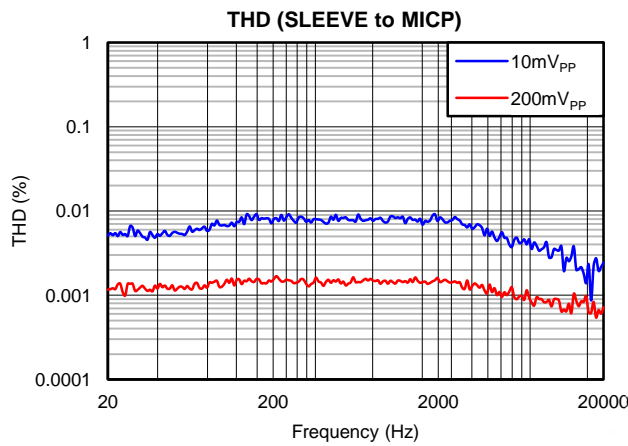

Figure 5.

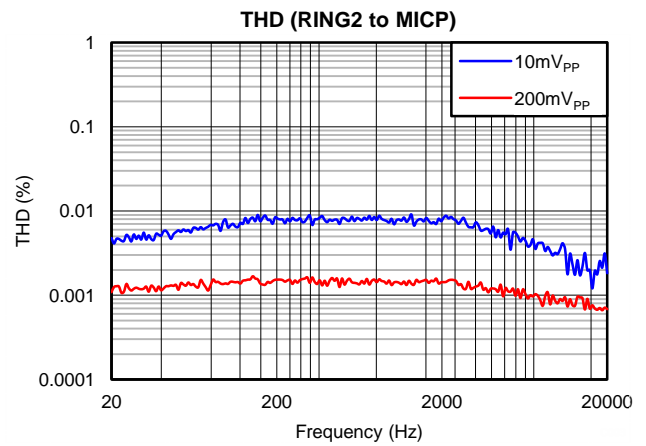

Figure 6.

REVISION HISTORY

Changes from Original (June 2013) to Revision A	Page
• Removed Machine Model ESD specification.	3
• Added EN=L or EN=H (after detection) to I _{DD} TEST CONDITIONS.	4
• Added typical values to R _{SW1} and R _{SW2}	4
• Added t _{dect} PARAMETER to KEY ELECTRICAL CHARACTERISTICS table.	4

PACKAGING INFORMATION

Orderable part number	Status (1)	Material type (2)	Package Pins	Package qty Carrier	RoHS (3)	Lead finish/ Ball material (4)	MSL rating/ Peak reflow (5)	Op temp (°C)	Part marking (6)
TS3A226AEYFFR	Active	Production	DSBGA (YFF) 9	3000 LARGE T&R	Yes	SNAGCU	Level-1-260C-UNLIM	-40 to 85	YP2 26AE
TS3A226AEYFFR.A	Active	Production	DSBGA (YFF) 9	3000 LARGE T&R	Yes	SNAGCU	Level-1-260C-UNLIM	-40 to 85	YP2 26AE

(1) **Status:** For more details on status, see our [product life cycle](#).

(2) **Material type:** When designated, preproduction parts are prototypes/experimental devices, and are not yet approved or released for full production. Testing and final process, including without limitation quality assurance, reliability performance testing, and/or process qualification, may not yet be complete, and this item is subject to further changes or possible discontinuation. If available for ordering, purchases will be subject to an additional waiver at checkout, and are intended for early internal evaluation purposes only. These items are sold without warranties of any kind.

(3) **RoHS values:** Yes, No, RoHS Exempt. See the [TI RoHS Statement](#) for additional information and value definition.

(4) **Lead finish/Ball material:** Parts may have multiple material finish options. Finish options are separated by a vertical ruled line. Lead finish/Ball material values may wrap to two lines if the finish value exceeds the maximum column width.

(5) **MSL rating/Peak reflow:** The moisture sensitivity level ratings and peak solder (reflow) temperatures. In the event that a part has multiple moisture sensitivity ratings, only the lowest level per JEDEC standards is shown. Refer to the shipping label for the actual reflow temperature that will be used to mount the part to the printed circuit board.

(6) **Part marking:** There may be an additional marking, which relates to the logo, the lot trace code information, or the environmental category of the part.

Multiple part markings will be inside parentheses. Only one part marking contained in parentheses and separated by a "-" will appear on a part. If a line is indented then it is a continuation of the previous line and the two combined represent the entire part marking for that device.

Important Information and Disclaimer: The information provided on this page represents TI's knowledge and belief as of the date that it is provided. TI bases its knowledge and belief on information provided by third parties, and makes no representation or warranty as to the accuracy of such information. Efforts are underway to better integrate information from third parties. TI has taken and continues to take reasonable steps to provide representative and accurate information but may not have conducted destructive testing or chemical analysis on incoming materials and chemicals. TI and TI suppliers consider certain information to be proprietary, and thus CAS numbers and other limited information may not be available for release.

In no event shall TI's liability arising out of such information exceed the total purchase price of the TI part(s) at issue in this document sold by TI to Customer on an annual basis.

TAPE AND REEL INFORMATION

QUADRANT ASSIGNMENTS FOR PIN 1 ORIENTATION IN TAPE

*All dimensions are nominal

Device	Package Type	Package Drawing	Pins	SPQ	Reel Diameter (mm)	Reel Width W1 (mm)	A0 (mm)	B0 (mm)	K0 (mm)	P1 (mm)	W (mm)	Pin1 Quadrant
TS3A226AEYFFR	DSBGA	YFF	9	3000	180.0	8.4	1.46	1.36	0.7	4.0	8.0	Q1

TAPE AND REEL BOX DIMENSIONS

*All dimensions are nominal

Device	Package Type	Package Drawing	Pins	SPQ	Length (mm)	Width (mm)	Height (mm)
TS3A226AEYFFR	DSBGA	YFF	9	3000	182.0	182.0	20.0

YFF0009

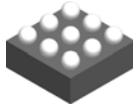

PACKAGE OUTLINE

DSBGA - 0.625 mm max height

DIE SIZE BALL GRID ARRAY

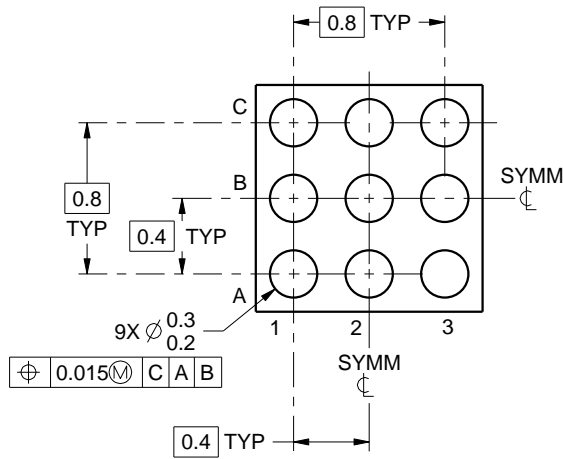
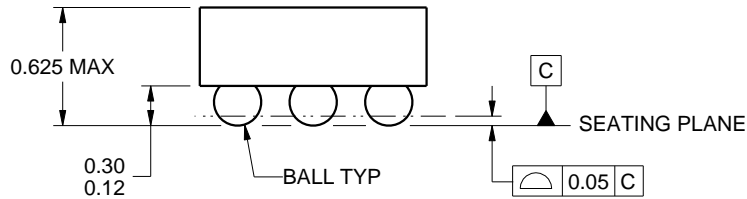
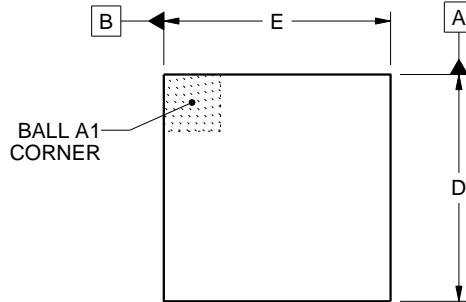

D: Max = 1.386 mm, Min = 1.326 mm
 E: Max = 1.286 mm, Min = 1.226 mm

4219552/A 05/2016

NOTES:

1. All linear dimensions are in millimeters. Any dimensions in parenthesis are for reference only. Dimensioning and tolerancing per ASME Y14.5M.
2. This drawing is subject to change without notice.

EXAMPLE BOARD LAYOUT

YFF0009

DSBGA - 0.625 mm max height

DIE SIZE BALL GRID ARRAY

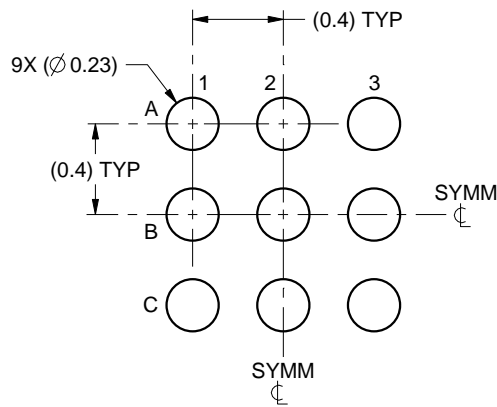

LAND PATTERN EXAMPLE
SCALE:30X

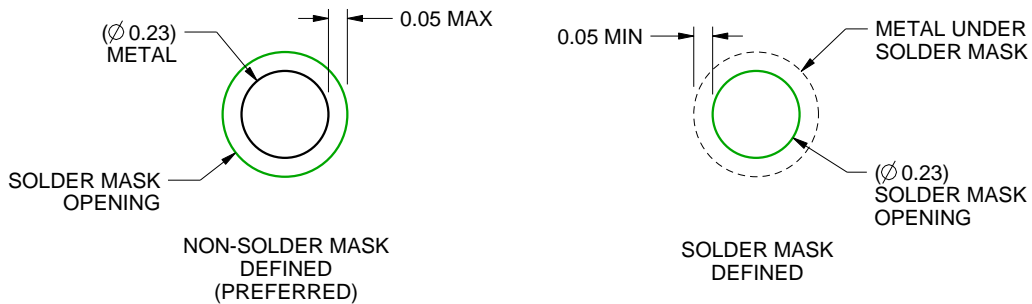

SOLDER MASK DETAILS
NOT TO SCALE

4219552/A 05/2016

NOTES: (continued)

3. Final dimensions may vary due to manufacturing tolerance considerations and also routing constraints. For more information, see Texas Instruments literature number SNVA009 (www.ti.com/lit/snva009).

EXAMPLE STENCIL DESIGN

YFF0009

DSBGA - 0.625 mm max height

DIE SIZE BALL GRID ARRAY

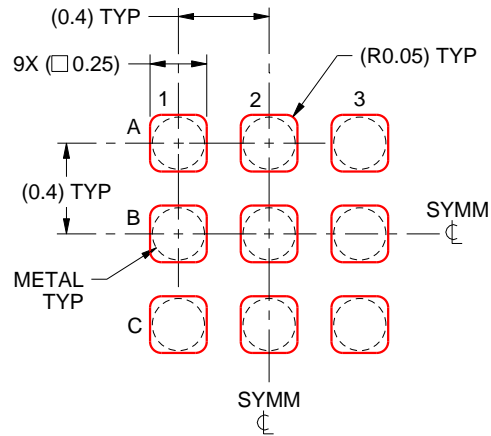

SOLDER PASTE EXAMPLE
BASED ON 0.1 mm THICK STENCIL
SCALE:30X

4219552/A 05/2016

NOTES: (continued)

4. Laser cutting apertures with trapezoidal walls and rounded corners may offer better paste release.

重要通知和免责声明

TI“按原样”提供技术和可靠性数据（包括数据表）、设计资源（包括参考设计）、应用或其他设计建议、网络工具、安全信息和其他资源，不保证没有瑕疵且不做任何明示或暗示的担保，包括但不限于对适销性、与某特定用途的适用性或不侵犯任何第三方知识产权的暗示担保。

这些资源可供使用 TI 产品进行设计的熟练开发人员使用。您将自行承担以下全部责任：(1) 针对您的应用选择合适的 TI 产品，(2) 设计、验证并测试您的应用，(3) 确保您的应用满足相应标准以及任何其他安全、安保法规或其他要求。

这些资源如有变更，恕不另行通知。TI 授权您仅可将这些资源用于研发本资源所述的 TI 产品的相关应用。严禁以其他方式对这些资源进行复制或展示。您无权使用任何其他 TI 知识产权或任何第三方知识产权。对于因您对这些资源的使用而对 TI 及其代表造成的任何索赔、损害、成本、损失和债务，您将全额赔偿，TI 对此概不负责。

TI 提供的产品受 [TI 销售条款](#)、[TI 通用质量指南](#) 或 [ti.com](#) 上其他适用条款或 TI 产品随附的其他适用条款的约束。TI 提供这些资源并不会扩展或以其他方式更改 TI 针对 TI 产品发布的适用的担保或担保免责声明。除非德州仪器 (TI) 明确将某产品指定为定制产品或客户特定产品，否则其产品均为按确定价格收入目录的标准通用器件。

TI 反对并拒绝您可能提出的任何其他或不同的条款。

版权所有 © 2025，德州仪器 (TI) 公司

最后更新日期：2025 年 10 月