

PROFINET[®] on TI's Sitara[™] processors



Robin Singh
*Sitara processors
Design Engineer*

Thomas Leyrer
*System Manager
Industrial Automation*

Texas Instruments

Executive summary

PROFINET® is the leading industrial Ethernet standard for industrial automation. Texas Instruments (TI) has integrated the PROFINET technology into its Sitara™ Arm®-based processors. To integrate PROFINET into the Sitara processors, TI has built upon its programmable real-time unit (PRU) technology to create an industrial communication sub-system (ICSS).

TI has implemented a two-port PROFINET cut-through switch on the PRU-ICSS to offload the real-time processing requirements of PROFINET from the Arm application processor to the PRU-ICSS. This leaves most of the processing power of the Arm application processor for industrial applications.

TI also offers the software, hardware and tools to streamline the development of PROFINET-based products with Sitara processors. Industrial grade temperature support and guaranteed long-term supply make Sitara processors a compelling choice for PROFINET and other industrial networking standards.

Introduction to PROFINET

Overview

PROFINET® is a real-time Ethernet standard for the high-speed, deterministic communications required for a wide range of industrial applications including factory automation, process automation and building automation. Originally developed under the leadership of Siemens GmbH as a network extension to the popular PROFIBUS® fieldbus technology, PROFINET is now supported by PROFIBUS & PROFINET International, the largest fieldbus organization in the world. In 2003, PROFINET was integrated into the IEC 61158 and IEC 61784 standards. Its architecture was developed by 30 working groups whose members represented more than 70 different companies.

Adapting Ethernet to support industrial applications creates a technology bridge between the worlds of corporate IT and the factory floor by using familiar

technologies such as TCP/IP and XML. Although standard Ethernet provides excellent solutions in an IT-centric corporate environment, it falls short on several counts for factory automation. Standard Ethernet is not efficient for the small amounts of data exchange that are typical in factory automation, for example, and lack of determinism means it cannot support the real-time operation necessary for motor drive control and other industrial real-time applications. PROFINET is a leading example of solving these challenges so that Ethernet can be adapted for real-time industrial applications.

Technology

PROFINET is based on the master-slave communication paradigm. The master (IO-Controller) can send and receive frames to and from all devices in the network. A slave (IO-Device) can send frames to the IO-Controller but traffic to other IO-Devices is only possible non-cyclically.

PROFINET's system model closely resembles the PROFIBUS fieldbus system.

Process data is exchanged between controller and slaves cyclically as real-time data. It provides a real-time interface for cyclic I/O data exchange that takes place directly on Layer 2 with EtherType 0x8892. Real-time data is not transferred using a standard TCP/IP stack, which reduces the latency of cyclic data transfer between the controller and slave. A VLAN tag with a high priority is used for cyclic data for the optimized processing in a network component.

The following device classes are defined in the PROFINET standard:

- **IO-Controller:** This is typically the programmable logic controller (PLC) that runs the industrial automation program. It is comparable to a Class 1 master in PROFIBUS. The IO-Controller provides output data to the configured IO-Devices and receives input data of IO-Devices.
- **IO-Device:** An IO-Device is a distributed I/O field device that is connected to one or more IO-Controllers via PROFINET. It is comparable to the function of a slave in PROFIBUS.
- **IO-Supervisor:** This can be a programming device, personal computer (PC), or human machine interface (HMI) device for

commissioning or diagnostic purposes and corresponds to a Class 2 master in PROFIBUS.

A system deployed in an industrial application has at least one IO-Controller and one or more IO-Devices. IO-Supervisors are usually integrated only temporarily for commissioning or troubleshooting purposes. **Figure 2** shows the various communications paths between the defined devices.

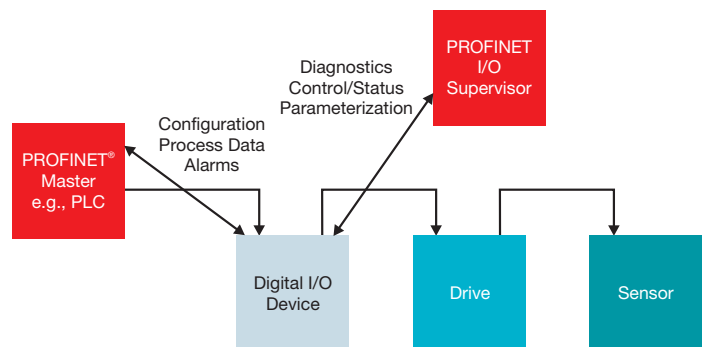

Figure 2: Communications paths for PROFINET.

Device model

PROFINET's device model is specified by its technical and functional features as described by Device Access Point (DAP) and the defined modules for a particular device family. A DAP is the access point for communication with the Ethernet interface and the processing program. A variety of I/O modules can be assigned to a DAP in order to manage the actual communication of process data.

The following standard structures apply to every IO-Device:

- The slot is the place where an I/O module is inserted in a modular IO-Device. Configured modules can contain one or more subslots that are used for data exchange and are addressed according to the different slots.
- Subslots implement the actual interface to the process. The granularity of a subslot (bit-wise, byte-wise, or word-wise division of I/O data) is

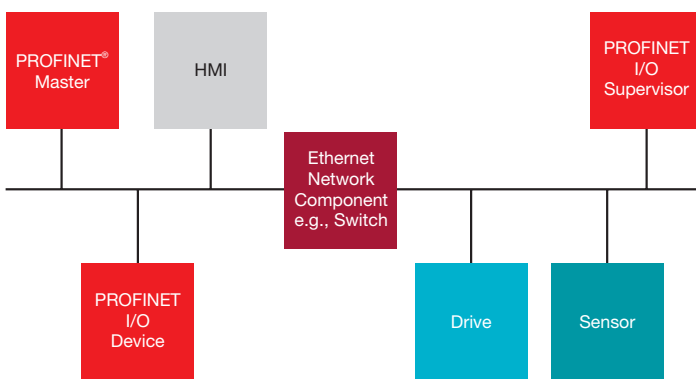

Figure 1: Example of a basic PROFINET network.

determined by the manufacturer. Data content of a subslot is always accompanied by status information so that the validity of the data can be determined.

- The index specifies the data within a slot/subslot that can be read or written acyclically via read/write services. Parameters can be written to a module, for example, or manufacturer-specific module data can be read out on the basis of an index.

PROFINET differentiates between compact field devices, in which the degree of expansion is already specified by the manufacturer and cannot be changed by the user, and modular field devices, in which the degree of expansion can be customized for a specific application when the system is configured.

Cyclic I/O data are addressed by specifying the slot/subslot combination, which are typically defined by the manufacturer. For acyclic data communication via read/write services, an application can specify the data to be addressed using slot, subslot and index.

To avoid competing accesses in the definition of user profiles (e.g., for PROFIdrive, weighing and dosing, etc.), the application programming interface (API) is defined as an additional addressing level.

Device descriptions

Every field device is accompanied by general station description (GSD) files so the devices can be configured for system engineering. This XML-based GSD describes the properties and functions and contains all data relevant for engineering as well as for data exchange with the field device. The field device manufacturer must supply the XML-based GSD in accordance with the GSDML specification.

Communication

Communication paths that must be established between the IO-Controller and an IO-Device are set up by the IO-Controller during system startup based on the configuration data in the engineering system. This explicitly specifies the data exchange.

Every data exchange is embedded into an Application Relation (AR). Within the AR, Communication Relations (CR) explicitly specify the data. All data for device modeling, including the general communication parameters, are downloaded to the IO-Device. An IO-Device can have multiple ARs established from different IO-Controllers. The communication channels for cyclic data exchange (IOCR), acyclic data exchange (record data CR), and alarms (alarm CR) are set up simultaneously.

Multiple IO-Controllers can be used, and it is necessary for multiple IO-Controllers to access the same data in the IO-Devices, this data sharing must be specified when configuring the IO-Devices.

An IO-Controller can establish one AR, each with multiple IO-Devices. Within an AR, several IOCRs and APIs can be used for data exchange. This can be useful, for example, if more than one user profile (PROFI-drive, Encoder, etc.) is involved in the communication and different subslots are required. The specified APIs serve to differentiate the data communication within an IOCR.

Addressing

In PROFINET, a unique name assigned to every field device is used when assigning the IP address. The Dynamic Configuration Protocol (DCP) for this purpose is integrated in every IO-Device.

The IP address is assigned with the DCP protocol based on the device name. Because Dynamic Host Configuration Protocol (DHCP) is widely used internationally, PROFINET has provided for optional

address settings via DHCP or manufacturer-specific mechanisms. The addressing options supported by a field device are defined in the GSD file for the respective field device.

Optionally, the name can also be automatically assigned to the IO-Device by means of a specified topology based on neighborhood detection. A PROFINET IO-Device is addressed for direct data exchange by its MAC address.

Conformance classes

PROFINET IO is divided into three conformance classes that build upon one other and are oriented to typical applications.

Conformance Class A (CC-A) can be implemented with standard Ethernet hardware and supports basic functions of cyclic real-time communication (RT frames) and acyclic TCP/IP communication. VLAN Tag is used in RT frames with a high priority according to IEEE 802.1Q to optimize their processing within a network component. These frames are given preference over non-real-time TCP/IP frames and are transmitted on the basis of MAC address. There is no synchronization between the devices, and the transmission cycle of an RT frame is defined by the system designer.

Conformance Class B (CC-B) includes all of the functionalities of Conformance Class A and extends the functionality by including network diagnostics and topology detection. Simple Network Management Protocol (SNMP) is used for this purpose, and its implementation is mandatory to conform to CC-B. Media Redundancy Protocol (MRP) is included in an extended version of CC-B named CC-B(PA).

Conformance Class C (CC-C) includes all of the functionalities of Conformance Class B and adds the critical feature of synchronization between IO-Devices. Bandwidth is reserved for high-precision

and deterministic data transmission. This is the basis for isochronous applications. The integrated PROFINET solution on TI's Sitara processors achieved Conformance Class-C (CC-C).

Components of a PROFINET node

Three layers conforming to the OSI model are included in each PROFINET node: the physical layer, the data link layer and an application layer, as shown in **Figure 3**.

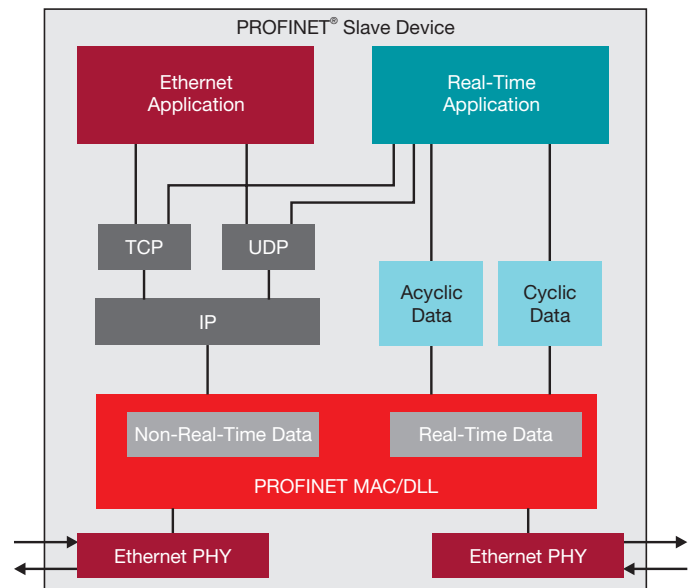

Figure 3: Components of a PROFINET node.

The physical layer is simply the medium that conveys the bitstream through the network. Since PROFINET is 100 percent Ethernet compatible, it can implement the physical layer with any Ethernet-capable twisted pair copper or fiber optic cabling that supports 100 Mbit/s data rates. Either an ASIC or an FPGA can be used to implement the MAC layer. The only restriction on the industrial application is that it support a standard TCP/IP and UDP/IP stack and Ethernet-based device profiles. Within the PROFINET node, the application can run on hardware or a combination of hardware and software running in an embedded CPU.

Typical PROFINET node

Current implementations of PROFINET nodes typically have one of the two architectures illustrated in **Figures 4** and **5**.



Figure 4: PROFINET switch with ASIC and external processor

Many of the PROFINET devices are created by using a two-chip architecture as shown in **Figure 5** where a PROFINET switch is implemented on an FPGA or ASIC and an external processor, often with on-chip Flash memory, is added to provide additional processing power for handling the application-level processing. Sensor applications are a good example of this type of node. The processor operates the sensor, implements the device driver and runs the PROFINET protocol stack. It allows designers to select a processor that suits their needs and cost targets, but PROFINET devices with this architecture are expensive because it involves two separate chips, and interface between host processor and ASIC can be a performance bottleneck.

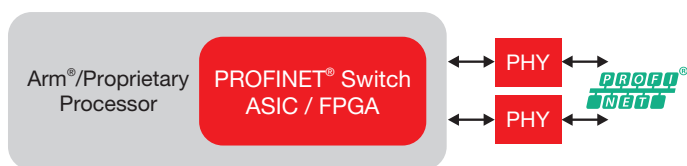

Figure 5: Integrated PROFINET switch with processor

In yet another approach, PROFINET devices can also be implemented such that PROFINET switch is implemented as one of the peripherals in a device with an integrated CPU, as shown in **Figure 5**. Many FPGA devices have the capability to configure a processor in the FPGA or already have an integrated processor. Some vendors provide ASICs

with both PROFINET and a suitable processor on the device. The FPGAs are flexible but depending on the CPU selection, there is a risk that cost or operating frequency targets are challenging to meet.

PROFINET solution from TI

TI has already integrated PROFINET functionality into Sitara processors. The combination of Arm Cortex-A processors and a wide variety of peripherals and interfaces that complement PROFINET make the Sitara processors attractive devices for industrial automation equipment.

Application processor offloaded

As shown in **Figure 6** on the following page, the Sitara processors feature TI's programmable real-time unit industrial communication subsystem (PRU-ICSS), which will support very low-level interaction with the MII interfaces. The PRU-ICSS can easily implement specialized communication protocols such as PROFINET. As in the integrated PROFINET solution on the Sitara AM335x, an entire PROFINET switch can be encapsulated in the PRU-ICSS through firmware, leaving the Arm application processor free for stack and application processing. Parsing of Consumer Protocol Machine (CPM) frames and generation of Provider Protocol Machine (PPM) frames can be handled completely by a PRU. Any frames which are not meant for the PROFINET node are cut-through to the next node by the switch included in the PROFINET PRU firmware on Sitara processors where the PROFINET protocol has been integrated by TI. This implementation allows the use of a lower speed variant of Arm application processors for simpler and cost-constrained applications, such as distributed I/O.

Interrupts are used for communication required with the Arm processor running the PROFINET stack (Layer 7) and industrial application. The PRU-ICSS can also perform frame forwarding in

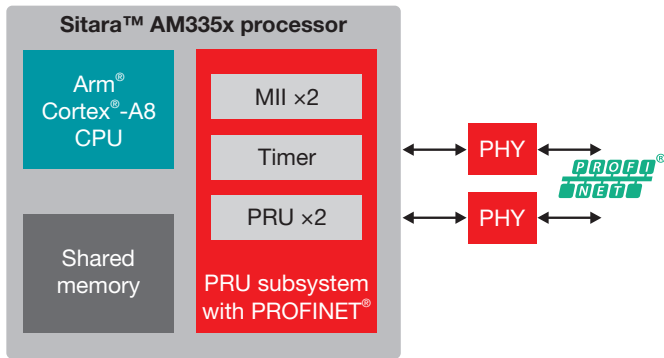

Figure 6: PROFINET slave on a TI Sitara™ AM335x processor

the reverse direction. Ethernet PHY devices, such as the TLK110 or DP83822 from TI, are used to complete TI's Sitara PROFINET solution. The TLK110 is optimized for low latency between the MII and PHY interfaces, which is an important performance attribute. The DP83822 provides flexibility to connect to a MAC through MII, RMII or RGMII interfaces. The TLK110 and DP83822 also have advanced cable diagnostics features that can quickly locate cable faults.

Conformance classes supported

TI's flexible PRU-ICSS supports all the conformance classes of PROFINET, as shown in Figure 7. This total integration of PROFINET has been certified at COMDEC lab for conformance classes A and B functionality with a third-party PROFINET stack.

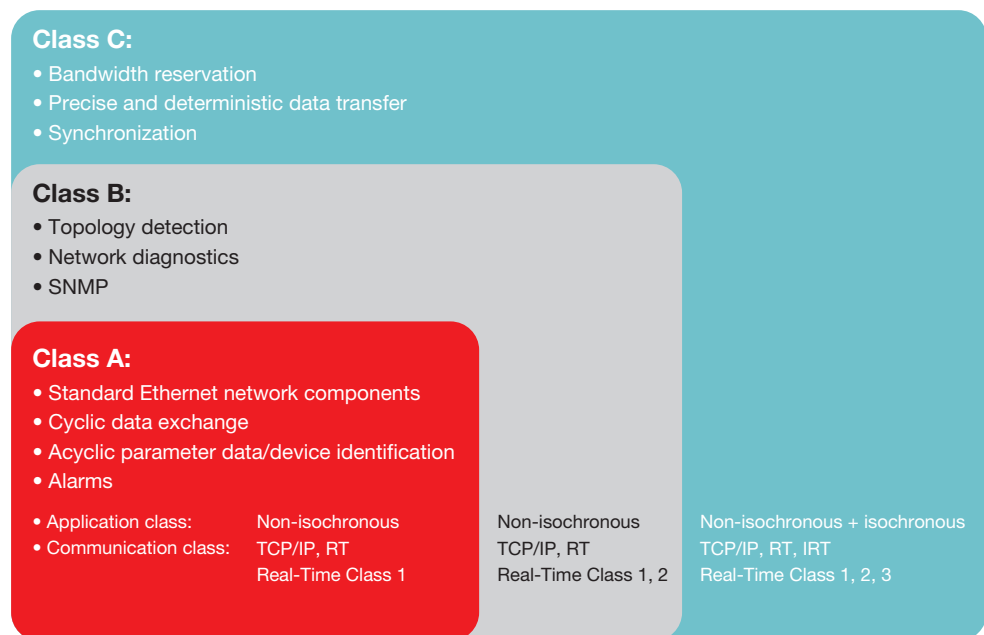

Figure 7: TI's PROFINET solution supported conformance classes

Shared devices and shared inputs

TI's integrated PROFINET solution on Sitara processors supports simultaneous multiple ARs with multiple controllers. It can establish up to eight ARs and eight IOCRs at a time. It allows other controllers to establish or close a connection while it is already exchanging I/O data with a separate controller. It supports shared inputs, thus allowing access by the multiple controllers to the same slot in a device.

Performance

Sitara processors' integrated PROFINET solution supports the minimum Send Clock Time or Phase Duration of 250 μs. It can support the minimum Send Clock Time of 250 μs across all the IOCRs established simultaneously with the device. It supports all the valid values of Reduction Ratio from 1 to 512. Cut-through latency of the integrated switch is in range of 1 to 2 μs irrespective of the frame size.

Robustness

The totally integrated Sitara PROFINET solution is very robust as it separates the PROFINET traffic

from the standard TCP/IP traffic. It has four priority queues on the host and port interfaces. The two highest priority queues are reserved for PROFINET

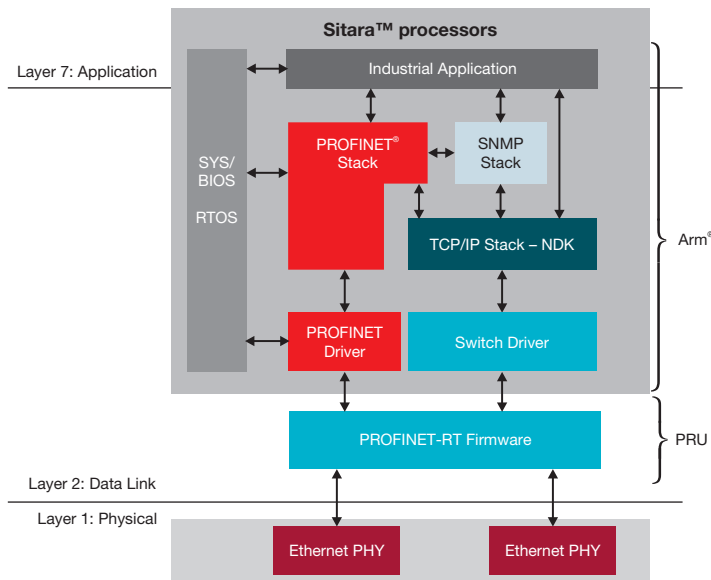

Figure 8: Software architecture for PROFINET slave on Sitara processors

frames and the last two for the TCP/IP frames. If a queue is full then the frames destined to that queue are dropped. If there is too much TCP/IP traffic, then it doesn't impact the PROFINET traffic as they use different queues. This separation of traffic into separate queues as per PROFINET QoS helps the device withstand any traffic in a large network.

Dedicated low-latency interface for cyclic data

PROFINET integrated onto the Sitara processor implements a low-latency real-time interface for cyclic I/O data exchange between the application and ICSS. Cyclic data frames are not received and transmitted through the host and port queues respectively. PROFINET cyclic data frames are terminated in the PRU-ICSS and data is directly provided to the application through triple buffer. Triple buffer management is used for exchanging the cyclic data so that the host and PRU-ICSS always find a buffer to store the data.

PROFINET software architecture

The PROFINET slave implementation integrated on Sitara processors has three major software components. The first is microcode that implements Layer 2 functionality in the device's PRU-ICSS; the second is the PROFINET slave stack that runs on the Arm processor; and, the third is the industrial application. TI provides additional components such as the protocol adaptation layer and device drivers in the software development kits that support its Sitara processors.

The architecture shown in Figure 8 works without alterations regardless of whether a TI-tested PROFINET protocol stack or a third-party stack is used. This integrated solution is also independent of the OS and any adaptations can be made by referring to TI's PROFINET API guides.

Firmware

The firmware architecture shown in Figure 9 shows the PROFINET slave capability integrated on the PRU-ICSS. In PROFINET Layer 2, the PRUs perform the tasks of CPM/PPM processing, Data Hold Timer (DHT), DCP Identify Filter, cut-through switching, error detection and host interface handling.

The PRU-ICSS provides an easy-to-use PROFINET register space in the internal shared

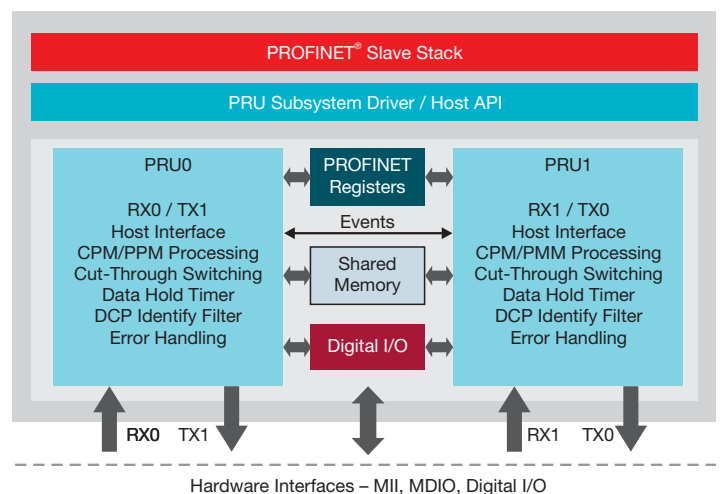

Figure 9: PROFINET firmware architecture

memory. Thanks to the PRU's deterministic real-time processing capability, PROFINET frames are handled with consistent and predictable processing latency.

CPM/PPM processing

CPM frames are parsed by the firmware to check whether the host processor should be notified. If the frame ID of the received CPM frame matches with the configured frame ID for an active IOCR, then only host is interrupted. Firmware stores the CPM frame in pre-defined buffer so that data is completely ready for host consumption before it is interrupted.

PPM frames for all the active IOCRs are generated/produced by the firmware running on the PRU-ICSS. The host only needs to initially configure all the information required for PPM frame generation for all the IOCRs using the TI's PROFINET APIs. At the start of every phase, firmware determines which all PPM frames need to be transmitted in that particular phase and transmits them out without any interference from host.

Data Hold Timer (DHT)

Data Hold Timer is implemented in the PRU-ICSS firmware, and whenever DHT expires, an interrupt is raised to the Arm processor running the PROFINET stack. One DHT is maintained by firmware for each IOCR or CPM connection. Whenever a CPM frame is received, firmware updates the data hold time for the associated IOCR. If DHT expires for a particular CPM, then firmware closes down all the PPM associated with that IOCR. The host processor is only interrupted when a DHT has expired. Given that multiple IOCRs can exist simultaneously, implementing DHT in firmware significantly reduces the Arm processor processing burden.

DCP identify filter

To reduce the number of DCP identify request frames reaching to the Arm processor, DCP Identify Filter is implemented in the PRU-ICSS firmware to filter out all the DCP identify frames which are not meant for the host. An API is provided in the driver for the stack to configure the station name and length, which are then used by firmware for filtering.

Integrated cut-through switch

A two-port cut-through switch is integrated in the PROFINET firmware. It handles the non-real-time traffic and can be interfaced with PROFINET and TCP/IP stacks running on the host. It implements PROFINET Filter Data Base (FDB) for multicast addresses and PROFINET quality of service (QoS) using four priority queues on host and port interfaces. Learning part of the switch is implemented on the host side.

Easy PROFINET integration

TI has streamlined the process of integrating PROFINET with Sitara processors. All the tools and software code required to integrate PROFINET slaves are available as part of the Processor Software Development Kit (Processor SDK) and on the PRU-ICSS industrial software page. On each development platform, the PRU-ICSS industrial software page and Processor SDK include firmware for the PROFINET protocol, software drivers, hardware initialization routines, adaptation layer for the stack API, PROFINET protocol stack and the application itself. The supporting documentation enables one to modify and build new features into the application.

To facilitate the integration of the PROFINET protocol stack, TI has collaborated closely with a third-party vendor to validate its PROFINET Slave

Stack Code on Sitara devices. This stack has been ported to work on the PRU-ICSS and tested to ensure seamless integration. Customers are expected to contact this third party to license the stack before taking their product to market. A copy of the PROFINET stack is included in the TI Sitara PRU-ICSS industrial software page in object form for evaluation, development and test purposes.

Integrating PROFINET on end products

In order to integrate PROFINET slave into industrial equipment, customers can use TI's integrated PROFINET slave implementation on Sitara processors and complete their design process using the evaluation copy of the PROFINET Slave Stack Code provided by TI. The Slave Stack Code has been obtained from a third-party vendor. If desired, customers can also use a slave stack from a different vendor or develop their own. The customer should use PROFINET IO Tester to pass all tests. Optionally, they can then get the product certified at COMDEC certification labs and may also perform broader interoperability tests at the PROFINET plug fests.

Development tools for PROFINET

To assist customers with their implementation, TI offers several industrial hardware development platforms complete with comprehensive documentation. Design data for these hardware platforms, such as schematics and layout can significantly accelerate customer designs. In addition, TI collaborates with a third-party vendor for an additional development platform targeted for industrial applications. For more information on the tools available for specific processors, [click here](#)

Summary

TI offers a totally integrated PROFINET slave capability on the Sitara processors. The integration of PROFINET with a powerful, low-power Arm core results in lower-cost end products without compromise on the functional or operational requirements. TI also offers transceivers with built-in isolation for industrial communication interfaces such as EtherCAT[®], EtherNet/IP[™], PROFIBUS[®] and more. With comprehensive software and hardware development tools, worldwide PROFINET support and an active TI E2E[™] developer community, customers can look forward to greatly simplified PROFINET integration with the added benefit of significant cost savings.

Important Notice: The products and services of Texas Instruments Incorporated and its subsidiaries described herein are sold subject to TI's standard terms and conditions of sale. Customers are advised to obtain the most current and complete information about TI products and services before placing orders. TI assumes no liability for applications assistance, customer's applications or product designs, software performance, or infringement of patents. The publication of information regarding any other company's products or services does not constitute TI's approval, warranty or endorsement thereof.

E2E and Sitara are trademarks of Texas Instruments Incorporated. All other trademarks are the property of their respective owners.

IMPORTANT NOTICE AND DISCLAIMER

TI PROVIDES TECHNICAL AND RELIABILITY DATA (INCLUDING DATASHEETS), DESIGN RESOURCES (INCLUDING REFERENCE DESIGNS), APPLICATION OR OTHER DESIGN ADVICE, WEB TOOLS, SAFETY INFORMATION, AND OTHER RESOURCES "AS IS" AND WITH ALL FAULTS, AND DISCLAIMS ALL WARRANTIES, EXPRESS AND IMPLIED, INCLUDING WITHOUT LIMITATION ANY IMPLIED WARRANTIES OF MERCHANTABILITY, FITNESS FOR A PARTICULAR PURPOSE OR NON-INFRINGEMENT OF THIRD PARTY INTELLECTUAL PROPERTY RIGHTS.

These resources are intended for skilled developers designing with TI products. You are solely responsible for (1) selecting the appropriate TI products for your application, (2) designing, validating and testing your application, and (3) ensuring your application meets applicable standards, and any other safety, security, or other requirements. These resources are subject to change without notice. TI grants you permission to use these resources only for development of an application that uses the TI products described in the resource. Other reproduction and display of these resources is prohibited. No license is granted to any other TI intellectual property right or to any third party intellectual property right. TI disclaims responsibility for, and you will fully indemnify TI and its representatives against, any claims, damages, costs, losses, and liabilities arising out of your use of these resources.

TI's products are provided subject to TI's Terms of Sale (www.ti.com/legal/termsofsale.html) or other applicable terms available either on ti.com or provided in conjunction with such TI products. TI's provision of these resources does not expand or otherwise alter TI's applicable warranties or warranty disclaimers for TI products.

Mailing Address: Texas Instruments, Post Office Box 655303, Dallas, Texas 75265
Copyright © 2018, Texas Instruments Incorporated