

Power Supply Rejection Error

TI Precision Labs – Current Sense Amplifiers

Presented by Benjamin Damkroger

Prepared by Guang Zhou and Jason Bridgmon

Hello, and welcome to the TI precision labs series on current sense amplifiers. My name is Benjamin Damkroger, and I'm a product marketing engineer in the Current & Position Sensing product line. In this video, we will take a closer look at power supply rejection error.

RSS total error equation

- The root-sum-square (RSS) total error is given by the following equation:

$$\zeta_{RSS} (\%) \approx \sqrt{V_{OS}^2 + CMRR^2 + PSRR^2 + Gain_Error^2 + Linearity^2 + Shunt_tolerance^2 + Bias_Current^2}$$

- In the device data sheet:

| PARAMETER | | CONDITIONS | MIN | TYP | MAX | UNIT |
|--------------|---|---|-----|-----------|-----------|------------------------------|
| INPUT | | | | | | |
| CMRR | Common-mode rejection ratio, RTI ⁽¹⁾ | $V_{IN+} = 0\text{ V to }26\text{ V}$, $V_{SENSE} = 10\text{ mV}$, $T_A = -40^\circ\text{C to }+125^\circ\text{C}$ | 84 | 100 | | dB |
| V_{OS} | Offset voltage ⁽²⁾ , RTI | | | ± 100 | ± 500 | μV |
| | | $V_{IN+} = 0\text{ V}$ | | ± 25 | ± 150 | |
| dV_{OS}/dT | Offset drift, RTI | $T_A = -40^\circ\text{C to }+125^\circ\text{C}$ | | 0.2 | 1 | $\mu\text{V}/^\circ\text{C}$ |
| PSRR | Power-supply rejection ratio, RTI | $V_S = 2.7\text{ V to }5.5\text{ V}$, $V_{SENSE} = 10\text{ mV}$ | | ± 8 | ± 40 | $\mu\text{V}/\text{V}$ |

In previous videos, we introduced the root-sum-of-squares, or RSS, total error equation for current sense amplifier circuits, as shown here. Note that not all error terms may be shown.

Most common error sources that are specified in typical datasheets include the following:

Input offset voltage or V_{os} ,

Common-mode rejection ratio or CMRR, and

Power supply rejection ratio or PSRR.

These errors are given in the electrical characteristics table of a device datasheet, as shown here.

The rest of this video focuses on PSRR.

Definition of Power Supply Rejection Ratio – PSRR

Definition

The change in the device's offset voltage created by a change in the amplifier's supply voltage

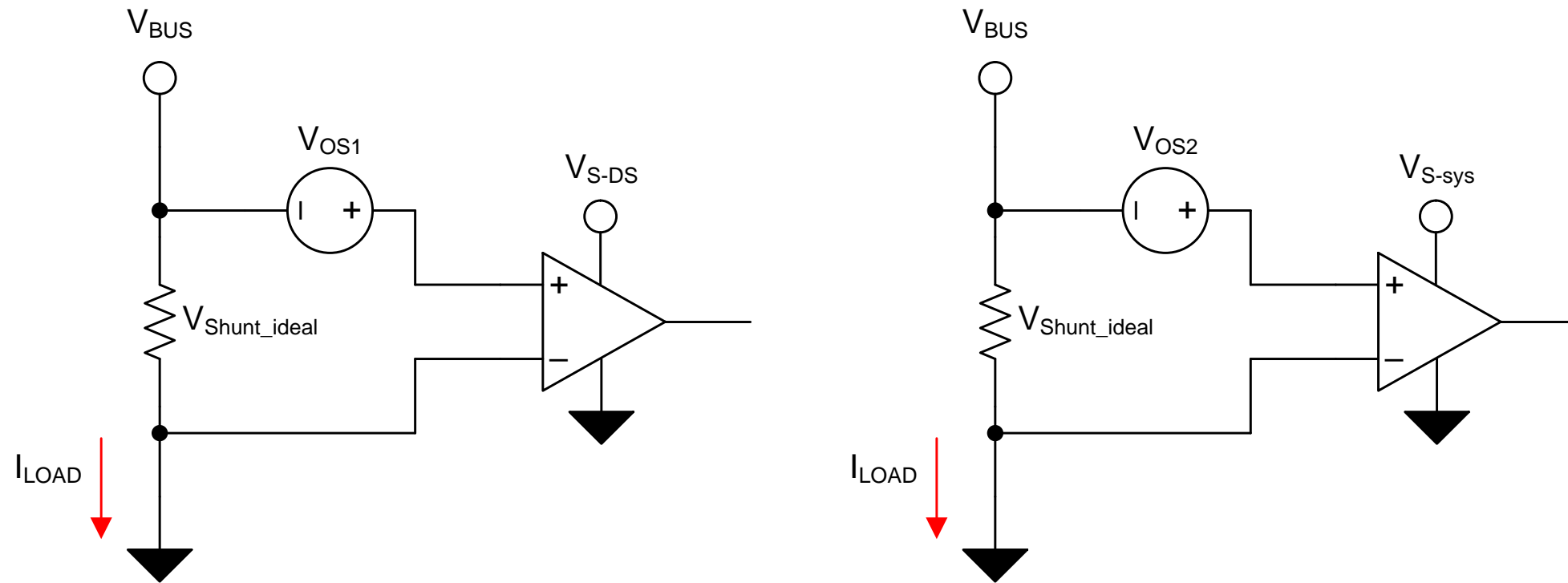

Power supply rejection ratio is a measure of the change in the device's offset voltage (V_{os}) induced by change in the amplifier's supply voltage (V_s).

Everything else kept the same, when amplifier supply voltage changes from V_{s-ds} , the typically power supply voltage given in the device electrical characteristics table, to V_{s-sys} , the power supply voltage in an application system, its input offset voltage changes from V_{os1} to V_{os2} . This change is characterized by PSRR. The smaller the change in V_{os} , the better the PSRR spec.

PSRR error equation

Error equation

$$e_{PSRR} = \frac{ABS(V_{S-DS} - V_{S-sys}) \times PSRR}{V_{Shunt_Ideal}} \times 100\%$$

- Error is calculated with respect to the **ideal** shunt voltage
- PSRR is specified in one of two ways
 - Linear: V/V (worst case is the maximum value)
 - Logarithmic: dB (worst case is the minimum value)
 - Relationship between the two: $PSRR_{V/V} = 10^{\frac{-PSRR_{dB}}{20}}$
- Error must be calculated with PSRR in V/V

The equation to calculate PSRR error is shown here. It is simply the ratio of the change in V_{os} caused by change of power supply relative to the ideal shunt voltage. V_{shunt_ideal} is the product of the load current and ideal shunt resistor value – ignoring the tolerance and temperature drift of the resistor itself, which will be discussed in other videos.

In device data sheet's you will find this specified either linearly in V/V or logarithmically in dB. Note that the worst case value depends on how it is specified.

PSRR error example – INA195

Conditions

- PSRR = 100 $\mu\text{V}/\text{V}$ at $V_{S-DS} = 12\text{ V}$
- $V_{S-sys} = 15\text{ V}$
- $V_{Shunt_ideal} = 20\text{ mV}$ ($I_{LOAD} = 20\text{ A}$; $R_{SHUNT} = 1\text{ m}\Omega$)

Calculations

$$e_{PSRR} = \frac{ABS(V_{S-DS} - V_{S-sys}) \times PSRR}{V_{Shunt_Ideal}} \times 100\% \longrightarrow e_{PSRR} = \frac{ABS(12\text{ V} - 15\text{ V}) \times 100\ \mu\text{V}/\text{V}}{20\text{ mV}} \times 100\% = \mathbf{1.5\%}$$

How to minimize

- Increase the shunt voltage drop – increase R_{SHUNT}
- Improve the power supply rejection ratio

7.5 Electrical Characteristics

All specifications at $T_A = 25^\circ\text{C}$, $V_S = 12\text{ V}$, $V_{IN+} = 12\text{ V}$, and $V_{SENSE} = 100\text{ mV}$, unless otherwise noted.

| PARAMETER | TEST CONDITIONS | TA = 25°C | | | TA = -40°C to +125°C | | | UNIT |
|-----------|-------------------------------------|---|-----|-----|----------------------|-----|-----|------------------------|
| | | MIN | TYP | MAX | MIN | TYP | MAX | |
| INPUT | | | | | | | | |
| PSR | Offset Voltage, RTI vs Power Supply | $V_S = 2.7\text{ V to }18\text{ V}$, $V_{IN+} = 18\text{ V}$ | | | | 5 | 100 | $\mu\text{V}/\text{V}$ |

Let's calculate the PSRR error in an example system with a nominal load current of 20 amps and ideal shunt resistance of 1 milliohms. We'll pick the INA195 as our amplifier. The ideal shunt voltage is equal to load current times shunt resistance, which results in 20 millivolts. The supply voltage utilized in the system is 15V. As mentioned, if the PSRR is specified logarithmically, first it needs to be converted to a linear specification, but in this case it is already specified linearly.

Using our PSRR error equation, we calculate that the resulting error is 1.5%. The first thing most engineers will ask is, how do we make it better and minimize this error? There are two possible ways to approach this.

First, you can increase the shunt voltage, which means increasing the shunt resistance. Second, you can make the PSRR spec better, which requires selecting a different device.

Increasing the shunt resistance may or may not be feasible due to cost, board space, or power dissipation concerns. Let's consider option 2, selecting a different device with better PSRR spec.

PSRR error example – INA214

Conditions

- PSRR = 10 $\mu\text{V}/\text{V}$ at $V_{S-DS} = 5\text{V}$
- $V_{S-sys} = 15\text{V}$
- $V_{Shunt_ideal} = 20\text{mV}$ ($I_{LOAD} = 20\text{A}$; $R_{SHUNT} = 1\text{m}\Omega$)

6.5 Electrical Characteristics

at $T_A = 25^\circ\text{C}$, $V_{SENSE} = V_{IN+} - V_{IN-}$

INA210, INA213, INA214, and INA215: $V_S = 5\text{V}$, $V_{IN+} = 12\text{V}$, and $V_{REF} = V_S / 2$, unless otherwise noted

INA211 and INA212: $V_S = 12\text{V}$, $V_{IN+} = 12\text{V}$, and $V_{REF} = V_S / 2$, unless otherwise noted

| PARAMETER | | TEST CONDITIONS | MIN | TYP | MAX | UNIT |
|-----------|---------------------------|--|-----|-----------|----------|------------------------|
| INPUT | | | | | | |
| PSRR | RTI vs power supply ratio | $V_S = 2.7\text{V to } 18\text{V}$ $V_{IN+} = 18\text{V}$ $V_{SENSE} = 0\text{mV}$ | | ± 0.1 | ± 10 | $\mu\text{V}/\text{V}$ |

Calculations

$$e_{PSRR} = \frac{ABS(V_{S-DS} - V_{S-sys}) \times PSRR}{V_{Shunt_Ideal}} \times 100\% \quad \longrightarrow \quad e_{PSRR} = \frac{ABS(5\text{V} - 15\text{V}) \times 10\ \mu\text{V}/\text{V}}{20\text{mV}} \times 100\% = \mathbf{0.5\%}$$

Note: Both PSRR and supply voltage delta (ΔV_S) affect the PSRR error

Lets take the same example we looked at previously, but substitute a device with improved PSRR, the INA214 at $10 \mu\text{V} / \text{V}$.

As you can see this results in an error of only 0.5%.

The other factor in the numerator is the major contributor to this error! The offset is specified at a supply of 5V, so by using a 15V system supply, that delta of 10V is greater than in the case of INA195, where the corresponding delta is 3V.

Had we used the same 3V supply voltage delta, the PSRR error would have been only 0.15%, a 10 times improvement over INA195.

PSRR error summary

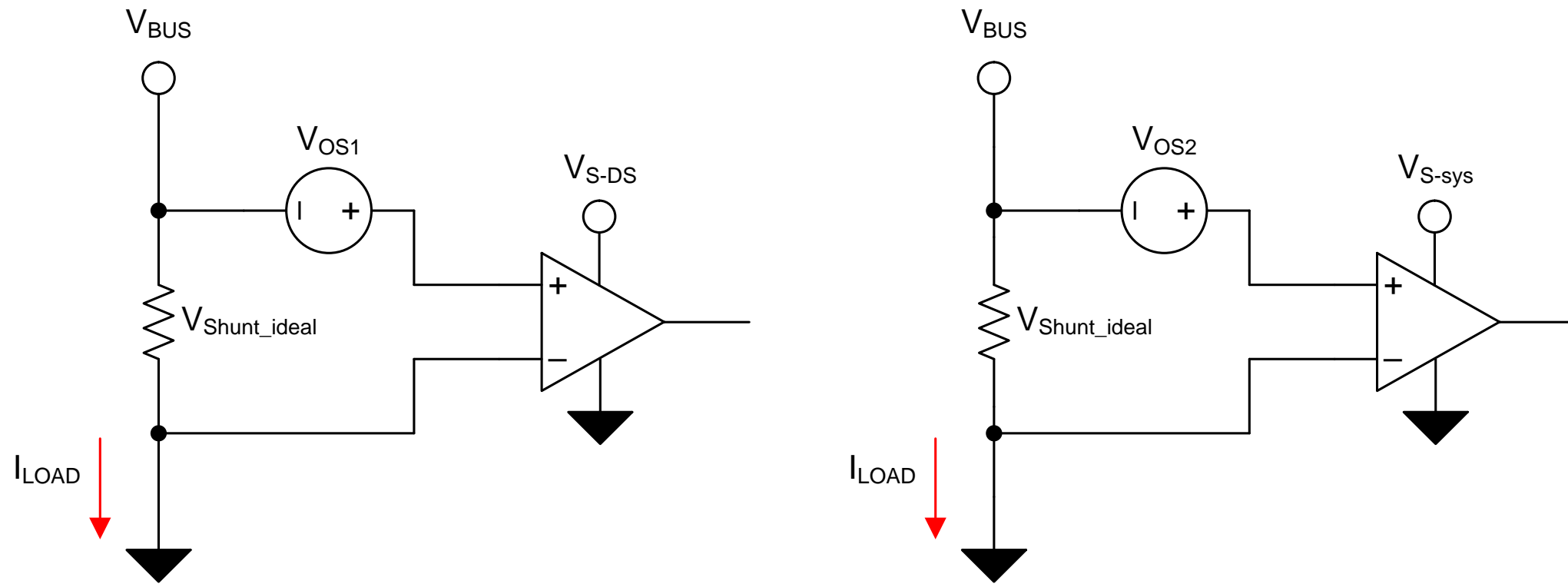

- PSRR error equation:

$$e_{PSRR} = \frac{ABS(V_{S-DS} - V_{S-sys}) \times PSRR}{V_{Shunt_Ideal}} \times 100\%$$

- To minimize PSRR error:

- Increase V_{SHUNT} – increase R_{SHUNT}
- Improve PSRR spec – select a different device

Let's take a minute to summarize what we learned in this video.

1. Power Supply Rejection Ratio is a measure of the change in the device's offset voltage induced by change in the amplifier's supply voltage.
2. Power supply rejection error is calculated with respect to the ideal shunt voltage.
3. Power supply rejection error is proportional to supply voltage delta.
4. To PSRR error, you can either increase V_{shunt} by increasing R_{shunt} , or improve PSRR spec by selecting a different device.

To find more current sense amplifier technical resources and search products, visit ti.com/currentsense

That concludes this video - thank you for watching! Please try the quiz to check your understanding of the content.

For more information and videos on current sense amplifiers please visit [ti.com/currentsense](https://www.ti.com/currentsense).

Power Supply Rejection Error

TI Precision Labs – Current Sense Amplifiers

Quiz

Power supply rejection error – quiz

1. Power supply rejection error is due to the finite rejection of variation in power supply by the current sense amplifier.
 - a) True
 - b) False

2. The power supply in my circuit is 5V, same as indicated by the datasheet “Electrical Characteristics” table test condition. Therefore, the effective PSRR error equals to zero, and can be ignored.
 - a) True
 - b) False

Power supply rejection error – quiz

3. In what unit is power supply rejection typically specified? (select all that apply)
- a) $\mu\text{V}/\text{V}$
 - b) %
 - c) μV
 - d) dB
4. A current sense amplifier has a fixed gain of 20. During characterization, you found that when its DC power supply varied 10V, its output varied 200 μV . What is its PSRR in $\mu\text{V}/\text{V}$?
- a) 2
 - b) 1
 - c) 20
 - d) 10

Answers

Power supply rejection error – quiz

1. Power supply rejection error is due to the finite rejection of variation in power supply by the current sense amplifier.

a) True

b) False

2. The power supply in my circuit is 5V, same as indicated by the datasheet “Electrical Characteristics” table test condition. Therefore, the effective PSRR error equals to zero , and can be ignored.

a) True

b) False

Power supply rejection error – quiz

3. In what unit is power supply rejection typically specified? (select all that apply)

a) $\mu\text{V}/\text{V}$

b) %

c) μV

d) dB

4. A current sense amplifier has a fixed gain of 20. During characterization, you found that when its DC power supply varied 10V, its output varied 200 μV . What is its PSRR in $\mu\text{V}/\text{V}$?

a) 2

b) 1

c) 20

d) 10