

# ISO14xx 5kV<sub>RMS</sub> Isolated RS-485/RS-422 Transceiver With Robust EMC

## 1 Features

- Compatible with TIA/EIA-485-A
- PROFIBUS compatible at 5V bus-side supply
- Bus I/O protection
  - ±30kV HBM
  - ±16kV IEC 61000-4-2 Contact discharge
  - ±4kV IEC 61000-4-4 Electrical fast transient
- Low-EMI 500kbps, 12Mbps and 50Mbps Data Rates
- 1.71V to 5.5V logic-side supply ( $V_{CC1}$ ), 3V to 5.5V bus-side supply ( $V_{CC2}$ )
- Failsafe receiver for bus open, short, and idle
- 1/8 Unit load up to 256 nodes on bus
- 100kV/ $\mu$ s (typical) high common-mode transient immunity
- Extended temperature range from –40°C to 125°C
- Glitch-free power-up and power-down for hot plug-in
- Wide-body SOIC-16 package
- Pin compatible to most isolated RS-485 transceivers
- Safety-related certifications:
  - 7071V<sub>PK</sub>  $V_{IOTM}$  and 1500V<sub>PK</sub>  $V_{IORM}$  (reinforced and basic options) per DIN VDE V 0884-11:2017-01
  - 5000V<sub>RMS</sub> isolation for 1 minute per UL 1577
  - IEC 60950-1, IEC 62368-1, IEC 60601-1 and IEC 61010-1 certifications
  - CQC, TUV, and CSA approvals

## 2 Applications

- [Grid infrastructure](#)
- [Solar inverter](#)
- [Factory automation & control](#)
- [Motor drives](#)
- [HVAC systems](#) and [building automation](#)

## 3 Description

The ISO14xx devices are galvanically-isolated differential line transceivers for TIA/EIA RS-485 and RS-422 applications. These noise-immune transceivers are designed to operate in harsh industrial environments. The bus pins of these devices can endure high levels of IEC electrostatic discharge (ESD) and IEC electrical fast transient (EFT) events which eliminates the need for additional components on bus for system-level protection. The devices are available for both basic and reinforced isolation (see [Reinforced and Basic Isolation Options](#)).

### Package Information

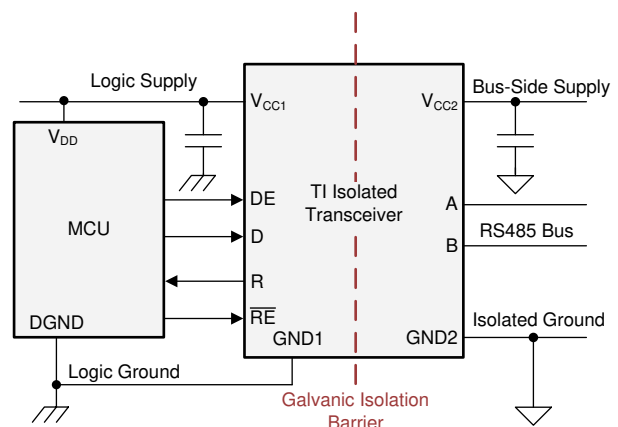
PART NUMBER	PACKAGE <sup>(1)</sup>	PACKAGE SIZE <sup>(2)</sup>
ISO1410, ISO1410B	SOIC (16)	10.30mm × 10.30mm
ISO1412, ISO1412B		
ISO1430, ISO1430B		
ISO1432, ISO1432B		
ISO1450, ISO1450B		
ISO1452, ISO1452B		

(1) For more information, see [Section 15](#).

(2) The package size (length × width) is a nominal value and includes pins, where applicable.

### Reinforced and Basic Isolation Options

Feature	ISO14xx	ISO14xxB
Protection level	Reinforced	Basic
Surge test voltage per VDE	10000V <sub>PK</sub>	6000V <sub>PK</sub>
Isolation rating per UL	5000V <sub>RMS</sub>	5000V <sub>RMS</sub>
Working voltage per VDE	1060V <sub>RMS</sub> / 1500V <sub>PK</sub>	1060V <sub>RMS</sub> / 1500V <sub>PK</sub>



**Simplified Application Schematic**



## Table of Contents

<b>1 Features</b> .....	1	7.16 Typical Characteristics.....	15
<b>2 Applications</b> .....	1	<b>8 Parameter Measurement Information</b> .....	21
<b>3 Description</b> .....	1	<b>9 Detailed Description</b> .....	24
<b>4 Description Continued</b> .....	2	9.1 Overview.....	24
<b>5 Device Comparison Table</b> .....	2	9.2 Functional Block Diagram.....	24
<b>6 Pin Configuration and Functions</b> .....	3	9.3 Feature Description.....	25
Pin Functions: Full-Duplex Device.....	3	9.4 Device Functional Modes.....	26
Pin Functions: Half-Duplex Device.....	4	<b>10 Application and Implementation</b> .....	29
<b>7 Specifications</b> .....	5	10.1 Application Information.....	29
7.1 Absolute Maximum Ratings.....	5	10.2 Typical Application.....	30
7.2 ESD Ratings.....	5	<b>11 Power Supply Recommendations</b> .....	33
7.3 Recommended Operating Conditions.....	6	<b>12 Layout</b> .....	34
7.4 Thermal Information.....	6	12.1 Layout Guidelines.....	34
7.5 Power Ratings.....	6	12.2 Layout Example.....	34
7.6 Insulation Specifications.....	7	<b>13 Device and Documentation Support</b> .....	36
7.7 Safety-Related Certifications.....	8	13.1 Documentation Support.....	36
7.8 Safety Limiting Values.....	8	13.2 Receiving Notification of Documentation Updates.....	36
7.9 Electrical Characteristics: Driver.....	9	13.3 Support Resources.....	36
7.10 Electrical Characteristics: Receiver.....	10	13.4 Trademarks.....	36
7.11 Supply Current Characteristics: Side 1 (I <sub>CC1</sub> ).....	11	13.5 Electrostatic Discharge Caution.....	36
7.12 Supply Current Characteristics: Side 2 (I <sub>CC2</sub> ).....	12	13.6 Glossary.....	37
7.13 Switching Characteristics: Driver.....	13	<b>14 Revision History</b> .....	37
7.14 Switching Characteristics: Receiver.....	14	<b>15 Mechanical, Packaging, and Orderable Information</b> .....	38
7.15 Insulation Characteristics Curves.....	14		

## 4 Description Continued

These devices are used for long distance communications. Isolation breaks the ground loop between the communicating nodes, allowing for a much larger common mode voltage range. The symmetrical isolation barrier of each device is tested to provide 5000V<sub>RMS</sub> of isolation for 1 minute per UL 1577 between the bus-line transceiver and the logic-level interface.

The ISO14xx devices can operate from 1.71V to 5.5V on side 1 which lets the devices be interfaced with low voltage FPGAs and ASICs. The wide supply voltage on side 2 from 3V to 5.5V eliminates the need for a regulated supply voltage on the isolated side. These devices support a wide operating ambient temperature range from –40°C to 125°C.

## 5 Device Comparison Table

The following table shows an overview of the options available for this family of devices.

Device	ISOLATION	DUPLEX	DATA RATE	PACKAGE
ISO1410, ISO1410B	Reinforced, Basic	Half	500Kbps	16-pin DW
ISO1412, ISO1412B		Full	500Kbps	16-pin DW
ISO1430, ISO1430B		Half	12Mbps	16-pin DW
ISO1432, ISO1432B		Full	12Mbps	16-pin DW
ISO1450, ISO1450B		Half	50Mbps	16-pin DW
ISO1452, ISO1452B		Full	50Mbps	16-pin DW

## 6 Pin Configuration and Functions

### Pin Functions: Full-Duplex Device

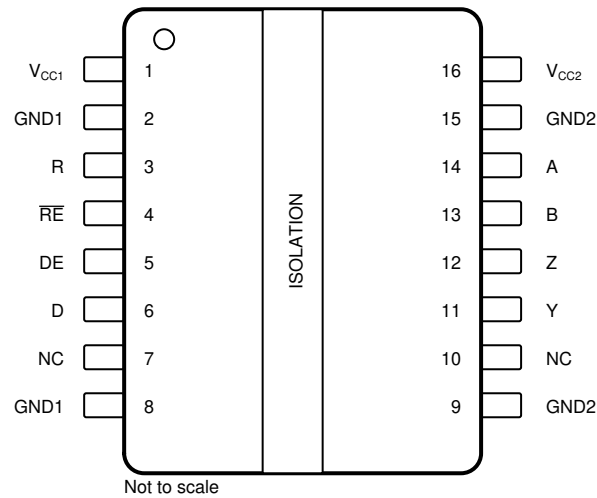


Figure 6-1. DW Package 16-Pin SOIC Full-Duplex Device Top View

PIN		Type <sup>(1)</sup>	DESCRIPTION
NAME	NO.		
A	14	I	Receiver non-inverting input on the bus side
B	13	I	Receiver inverting input on the bus side
D	6	I	Driver input
DE	5	I	Driver enable. This pin enables the driver output when high and disables the driver output when low or open.
GND1 <sup>(2)</sup>	2	—	Ground connection for V <sub>CC1</sub>
GND1 <sup>(2)</sup>	8	—	Ground connection for V <sub>CC1</sub>
GND2 <sup>(2)</sup>	9	—	Ground connection for V <sub>CC2</sub>
GND2 <sup>(2)</sup>	15	—	Ground connection for V <sub>CC2</sub>
NC <sup>(3)</sup>	7	—	No internal connection
NC <sup>(3)</sup>	10	—	No internal connection
R	3	O	Receiver output
RE	4	I	Receiver enable. This pin disables the receiver output when high or open and enables the receiver output when low.
V <sub>CC1</sub>	1	—	Logic-side power supply
V <sub>CC2</sub>	16	—	Transceiver-side power supply
Y	11	O	Driver non-inverting output
Z	12	O	Driver inverting output

(1) I = Input, O = Output

(2) For Logic side, both Pin 2 and Pin 8 must be connected to GND1. For Bus side, both Pin 9 and Pin 15 must be connected to GND2.

(3) Device functionality is not affected if NC pins are connected to supply or ground on PCB

## Pin Functions: Half-Duplex Device

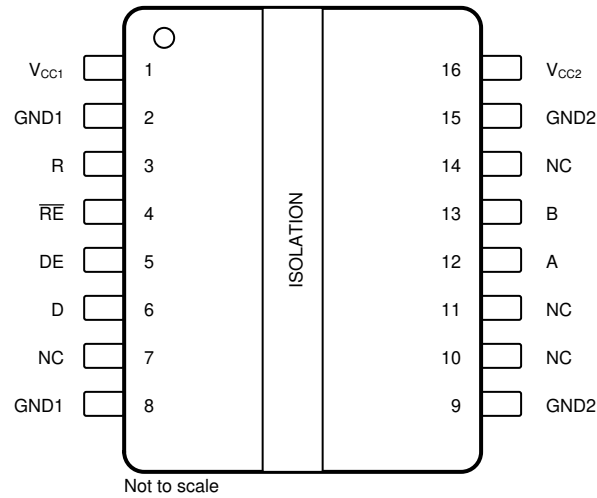


Figure 6-2. DW Package 16-Pin SOIC Half-Duplex Device Top View

PIN		Type <sup>(1)</sup>	DESCRIPTION
NAME	NO.		
A	12	I/O	Transceiver non-inverting input or output (I/O) on the bus side
B	13	I/O	Transceiver inverting input or output (I/O) on the bus side
D	6	I	Driver input
DE	5	I	Driver enable. This pin enables the driver output when high and disables the driver output when low or open.
GND1 <sup>(2)</sup>	2	—	Ground connection for V <sub>CC1</sub>
GND1 <sup>(2)</sup>	8	—	Ground connection for V <sub>CC1</sub>
GND2 <sup>(2)</sup>	9	—	Ground connection for V <sub>CC2</sub>
GND2 <sup>(2)</sup>	15	—	Ground connection for V <sub>CC2</sub>
NC <sup>(3)</sup>	7	—	No internal connection
NC <sup>(3)</sup>	10	—	No internal connection
NC <sup>(3)</sup>	11	—	No internal connection
NC <sup>(3)</sup>	14	—	No internal connection
R	3	O	Receiver output
RE	4	I	Receiver enable. This pin disables the receiver output when high or open and enables the receiver output when low.
V <sub>CC1</sub>	1	—	Logic-side power supply
V <sub>CC2</sub>	16	—	Transceiver-side power supply

(1) I = Input, O = Output, I/O = Input or Output

(2) For Logic side, both Pin 2 and Pin 8 must be connected to GND1. For Bus side, both Pin 9 and Pin 15 must be connected to GND2.

(3) Device functionality is not affected if NC pins are connected to supply or ground on PCB

## 7 Specifications

### 7.1 Absolute Maximum Ratings

Over operating free-air temperature range (unless otherwise noted)<sup>(1) (2)</sup>

		MIN	MAX	UNIT
V <sub>CC1</sub>	Supply voltage, side 1	-0.5	6	V
V <sub>CC2</sub>	Supply voltage, side 2	-0.5	6	V
V <sub>IO</sub>	Logic voltage level (D, DE, $\overline{RE}$ , R)	-0.5	V <sub>CC1</sub> +0.5 <sup>(3)</sup>	V
I <sub>O</sub>	Output current on R pin	-15	15	mA
V <sub>BUS</sub>	Voltage on bus pins (A, B, Y, Z w.r.t GND2)	-18	18	V
T <sub>J</sub>	Junction temperature	-40	150	°C
T <sub>STG</sub>	Storage temperature	-65	150	°C

- (1) Stresses beyond those listed under *Absolute Maximum Ratings* may cause permanent damage to the device. These are stress ratings only, which do not imply functional operation of the device at these or any other conditions beyond those indicated under *Recommended Operating Conditions*. Exposure to absolute-maximum-rated conditions for extended periods may affect device reliability.
- (2) All voltage values except differential I/O bus voltages are with respect to the local ground terminal (GND1 or GND2) and are peak voltage values.
- (3) Maximum voltage must not exceed 6 V

### 7.2 ESD Ratings

			VALUE	UNIT
V <sub>(ESD)</sub>	Contact Discharge, per IEC 61000-4-2	Pins Bus terminals and GND2	±16000	V
V <sub>(ESD)</sub>	Contact Discharge, per IEC 61000-4-2	ISO141x, Pins Bus terminals and GND1 (across isolation barrier)	±8000	V
V <sub>(ESD)</sub>	Contact Discharge, per IEC 61000-4-2	ISO143x, Pins Bus terminals and GND1 (across isolation barrier)	±8000	V
V <sub>(ESD)</sub>	Electrostatic discharge Human body model (HBM), per ANSI/ESDA/JEDEC JS-001	All pins except bus pins <sup>(1)</sup>	±6000	V
		Bus terminals to GND2 <sup>(1)</sup>	±30000	V
	Electrostatic discharge Charged device model (CDM), per JEDEC specification JESD22-C101	All pins <sup>(2)</sup>	±1500	

- (1) JEDEC document JEP155 states that 500-V HBM allows safe manufacturing with a standard ESD control process.
- (2) JEDEC document JEP157 states that 250-V CDM allows safe manufacturing with a standard ESD control process.

### 7.3 Recommended Operating Conditions

		MIN	MAX	UNIT
V <sub>CC1</sub>	Supply Voltage, Side 1, 1.8-V operation	1.71	1.89	V
	Supply Voltage, Side 1, 2.5-V, 3.3-V and 5.5-V operation	2.25	5.5	V
V <sub>CC2</sub>	Supply Voltage, Side 2	3	5.5	V
V <sub>I</sub>	Common Mode voltage at any bus terminal: A or B	-7	12	V
V <sub>IH</sub>	High-level input voltage (D, DE, $\overline{RE}$ inputs)	0.7*V <sub>CC1</sub>	V <sub>CC1</sub>	V
V <sub>IL</sub>	Low-level input voltage (D, DE, $\overline{RE}$ inputs)	0	0.3*V <sub>CC1</sub>	V
V <sub>ID</sub>	Differential input voltage, A with respect to B	-15	15	V
I <sub>O</sub>	Output current, Driver	-60	60	mA
I <sub>OR</sub>	Output current, Receiver	-4	4	mA
R <sub>L</sub>	Differential load resistance	54		Ω
1/t <sub>UI</sub>	Signaling rate ISO141x		500	kbps
1/t <sub>UI</sub>	Signaling Rate ISO143x		12	Mbps
1/t <sub>UI</sub>	Signaling rate ISO145x		50	Mbps
T <sub>A</sub>	Operating ambient temperature	-40	125	°C

### 7.4 Thermal Information

THERMAL METRIC <sup>(1)</sup>		ISO14xx	UNIT
		DW (SOIC)	
		16 PINS	
R <sub>θJA</sub>	Junction-to-ambient thermal resistance	67.9	°C/W
R <sub>θJC(top)</sub>	Junction-to-case (top) thermal resistance	27.7	°C/W
R <sub>θJB</sub>	Junction-to-board thermal resistance	29.4	°C/W
ψ <sub>JT</sub>	Junction-to-top characterization parameter	12.9	°C/W
ψ <sub>JB</sub>	Junction-to-board characterization parameter	28.8	°C/W
R <sub>θJC(bot)</sub>	Junction-to-case (bottom) thermal resistance	—	°C/W

(1) For more information about traditional and new thermal metrics, see the [Semiconductor and IC Package Thermal Metrics application report](#).

### 7.5 Power Ratings

PARAMETER		TEST CONDITIONS	MIN	TYP	MAX	UNIT
<b>ISO1410_ISO1412</b>						
P <sub>D</sub>	Maximum power dissipation (both sides)	V <sub>CC1</sub> = V <sub>CC2</sub> = 5.5 V, T <sub>J</sub> = 150°C, A-B load = 54 Ω   50pF, Load on R=15pF Input a 250kHz 50% duty cycle square wave to D pin with V <sub>DE</sub> =V <sub>CC1</sub> , V <sub>RE</sub> =GND1			556	mW
P <sub>D1</sub>	Maximum power dissipation (side-1)				28	mW
P <sub>D2</sub>	Maximum power dissipation (side-2)				528	mW
<b>ISO1430_ISO1432</b>						
P <sub>D</sub>	Maximum power dissipation (both sides)	V <sub>CC1</sub> = V <sub>CC2</sub> = 5.5 V, T <sub>J</sub> = 150°C, A-B load = 54 Ω   50pF, Load on R=15pF Input a 6MHz 50% duty cycle square wave to D pin with V <sub>DE</sub> =V <sub>CC1</sub> , V <sub>RE</sub> =GND1			352	mW
P <sub>D1</sub>	Maximum power dissipation (side-1)				33	mW
P <sub>D2</sub>	Maximum power dissipation (side-2)				319	mW
<b>ISO1450_ISO1452</b>						
P <sub>D</sub>	Maximum power dissipation (both sides)	V <sub>CC1</sub> = V <sub>CC2</sub> = 5.5 V, T <sub>J</sub> = 150°C, A-B load = 54 Ω   50pF, Load on R=15pF Input a 25MHz 50% duty cycle square wave to D pin with V <sub>DE</sub> =V <sub>CC1</sub> , V <sub>RE</sub> =GND1			588	mW
P <sub>D1</sub>	Maximum power dissipation (side-1)				49	mW
P <sub>D2</sub>	Maximum power dissipation (side-2)				539	mW

## 7.6 Insulation Specifications

PARAMETER		TEST CONDITIONS	SPECIFICATIONS	UNIT
			DW-16	
<b>IEC 60664-1</b>				
CLR	External clearance <sup>(1)</sup>	Side 1 to side 2 distance through air	>8	mm
CPG	External creepage <sup>(1)</sup>	Side 1 to side 2 distance across package surface	>8	mm
DTI	Distance through the insulation	Minimum internal gap (internal clearance)	>17	μm
CTI	Comparative tracking index	IEC 60112; UL 746A	>600	V
	Material Group	According to IEC 60664-1	I	
	Overvoltage category	Rated mains voltage ≤ 600 V <sub>RMS</sub>	I-IV	
		Rated mains voltage ≤ 1000 V <sub>RMS</sub>	I-III	
<b>DIN VDE V 0884-11:2017-01<sup>(2)</sup></b>				
V <sub>IORM</sub>	Maximum repetitive peak isolation voltage	AC voltage (bipolar)	1500	V <sub>PK</sub>
V <sub>IOWM</sub>	Maximum working isolation voltage	AC voltage (sine wave); time-dependent dielectric breakdown (Tddb) test; see <a href="#">Figure 10-7</a>	1060	V <sub>RMS</sub>
		DC voltage	1500	V <sub>DC</sub>
V <sub>IOTM</sub>	Maximum transient isolation voltage	V <sub>TEST</sub> = V <sub>IOTM</sub> , t = 60 s (qualification); V <sub>TEST</sub> = 1.2 × V <sub>IOTM</sub> , t = 1 s (100% production)	7071	V <sub>PK</sub>
V <sub>IOSM</sub>	Maximum surge isolation voltage ISO141x <sup>(3)</sup>	Test method per IEC 62368-1, 1.2/50 μs waveform, V <sub>TEST</sub> = 1.6 × V <sub>IOSM</sub> = 10000 V <sub>PK</sub> (qualification)	6250	V <sub>PK</sub>
	Maximum surge isolation voltage ISO141xB <sup>(3)</sup>	Test method per IEC 62368-1, 1.2/50 μs waveform, V <sub>TEST</sub> = 1.3 × V <sub>IOSM</sub> = 6000 V <sub>PK</sub> (qualification)	4615	V <sub>PK</sub>
q <sub>pd</sub>	Apparent charge <sup>(4)</sup>	Method a: After I/O safety test subgroup 2/3, V <sub>ini</sub> = V <sub>IOTM</sub> , t <sub>ini</sub> = 60 s; V <sub>pd(m)</sub> = 1.2 × V <sub>IORM</sub> , t <sub>m</sub> = 10 s	≤ 5	pC
		Method a: After environmental tests subgroup 1, V <sub>ini</sub> = V <sub>IOTM</sub> , t <sub>ini</sub> = 60 s; ISO14xx: V <sub>pd(m)</sub> = 1.6 × V <sub>IORM</sub> , t <sub>m</sub> = 10 s; ISO14xxB: V <sub>pd(m)</sub> = 1.2 × V <sub>IORM</sub> , t <sub>m</sub> = 10 s	≤ 5	
		Method b1: At routine test (100% production) and preconditioning (type test), V <sub>ini</sub> = V <sub>IOTM</sub> , t <sub>ini</sub> = 1 s; ISO14xx: V <sub>pd(m)</sub> = 1.875 × V <sub>IORM</sub> , t <sub>m</sub> = 1 s; ISO14xxB: V <sub>pd(m)</sub> = 1.5 × V <sub>IORM</sub> , t <sub>m</sub> = 1 s	≤ 5	
C <sub>IO</sub>	Barrier capacitance, input to output <sup>(5)</sup>	V <sub>IO</sub> = 0.4 × sin(2 πft), f = 1 MHz	1	pF
R <sub>IO</sub>	Insulation resistance, input to output <sup>(5)</sup>	V <sub>IO</sub> = 500 V, T <sub>A</sub> = 25°C	> 10 <sup>12</sup>	Ω
		V <sub>IO</sub> = 500 V, 100°C ≤ T <sub>A</sub> ≤ 150°C	> 10 <sup>11</sup>	
		V <sub>IO</sub> = 500 V at T <sub>S</sub> = 150°C	> 10 <sup>9</sup>	
	Pollution degree		2	
	Climatic category		40/125/21	
<b>UL 1577</b>				
V <sub>ISO</sub>	Withstand isolation voltage	V <sub>TEST</sub> = V <sub>ISO</sub> , t = 60 s (qualification); V <sub>TEST</sub> = 1.2 × V <sub>ISO</sub> , t = 1 s (100% production)	5000	V <sub>RMS</sub>

- (1) Creepage and clearance requirements should be applied according to the specific equipment isolation standards of an application. Care should be taken to maintain the creepage and clearance distance of a board design to ensure that the mounting pads of the isolator on the printed-circuit board do not reduce this distance. Creepage and clearance on a printed-circuit board become equal in certain cases. Techniques such as inserting grooves, ribs, or both on a printed circuit board are used to help increase these specifications.
- (2) ISO14xx is suitable for *safe electrical insulation* and ISO14xxB is suitable for *basic electrical insulation* only within the safety ratings. Compliance with the safety ratings shall be ensured by means of suitable protective circuits.
- (3) Testing is carried out in air or oil to determine the intrinsic surge immunity of the isolation barrier.
- (4) Apparent charge is electrical discharge caused by a partial discharge (pd).
- (5) All pins on each side of the barrier tied together creating a two-pin device.

## 7.7 Safety-Related Certifications

VDE	CSA	UL	CQC	TUV
Certified according to DIN VDE V 0884-11:2017- 01	Certified according to IEC 60950-1, IEC 62368-1 and IEC 60601-1	Recognized under UL 1577 Component Recognition Program	Certified according to GB4943.1-2011	Certified according to EN 61010-1:2010/A1:2019, EN 60950-1:2006/A2:2013 and EN 62368-1:2014
Maximum transient isolation voltage, 7071 V <sub>PK</sub> ; Maximum repetitive peak isolation voltage, 1500 V <sub>PK</sub> ; Maximum surge isolation voltage, ISO141x, ISO143x, ISO145x: 6250 V <sub>PK</sub> (Reinforced) ISO141xB, ISO143xB, ISO145xB: 4600 V <sub>PK</sub> (Basic)	CSA 60950-1-07+A1+A2, IEC 60950-1 2nd Ed.+A1+A2, CSA 62368-1-14, and IEC 62368-1 2nd Ed., for pollution degree 2, material group I ISO141x, ISO143x, ISO145x: 800 V <sub>RMS</sub> reinforced isolation ISO141xB, ISO143xB, ISO145xB: 800 V <sub>RMS</sub> basic isolation ----- CSA 60601- 1:14 and IEC 60601-1 Ed. 3.1, ISO141x, ISO143x, ISO145x: 2 MOPP (Means of Patient Protection) 250 V <sub>RMS</sub> (354 V <sub>PK</sub> ) maximum working voltage	Single protection, 5000 V <sub>RMS</sub>	Reinforced insulation, Altitude ≤ 5000 m, Tropical Climate, 700 V <sub>RMS</sub> maximum working voltage	EN 61010-1:2010 / A1:2019 ISO141x, ISO143x, ISO145x: 600 V <sub>RMS</sub> reinforced isolation ISO141xB, ISO143xB, ISO145xB: 1000 V <sub>RMS</sub> basic isolation ----- EN 60950-1:2006/A2:2013 and EN 62368-1:2014 ISO141x, ISO143x, ISO145x: 800 V <sub>RMS</sub> reinforced isolation ISO141xB, ISO143xB, ISO145xB: 1060 V <sub>RMS</sub> basic isolation
Reinforced certificate:40040142 Basic certificate: 40047657	Master contract number: 220991	File number: E181974	Certificate number: CQC15001121716	Client ID number: 77311

## 7.8 Safety Limiting Values

Safety limiting<sup>(1)</sup> intends to minimize potential damage to the isolation barrier upon failure of input or output circuitry.

PARAMETER		TEST CONDITIONS	MIN	TYP	MAX	UNIT
<b>DW-16 PACKAGE</b>						
I <sub>S</sub>	Safety input, output, or supply current	R <sub>θJA</sub> = 67.9°C/W, V <sub>I</sub> = 5.5 V, T <sub>J</sub> = 150°C, T <sub>A</sub> = 25°C, see <a href="#">Figure 7-1</a>			334	mA
		R <sub>θJA</sub> = 67.9°C/W, V <sub>I</sub> = 3.6 V, T <sub>J</sub> = 150°C, T <sub>A</sub> = 25°C, see <a href="#">Figure 7-1</a>			511	
		R <sub>θJA</sub> = 67.9°C/W, V <sub>I</sub> = 2.75 V, T <sub>J</sub> = 150°C, T <sub>A</sub> = 25°C, see <a href="#">Figure 7-1</a>			669	
		R <sub>θJA</sub> = 67.9°C/W, V <sub>I</sub> = 1.89 V, T <sub>J</sub> = 150°C, T <sub>A</sub> = 25°C, see <a href="#">Figure 7-1</a>			974	
P <sub>S</sub>	Safety input, output, or total power	R <sub>θJA</sub> = 67.9°C/W, T <sub>J</sub> = 150°C, T <sub>A</sub> = 25°C, see <a href="#">Figure 7-2</a>			1837	mW
T <sub>S</sub>	Maximum safety temperature				150	°C

- (1) The maximum safety temperature, T<sub>S</sub>, has the same value as the maximum junction temperature, T<sub>J</sub>, specified for the device. The I<sub>S</sub> and P<sub>S</sub> parameters represent the safety current and safety power respectively. The maximum limits of I<sub>S</sub> and P<sub>S</sub> should not be exceeded. These limits vary with the ambient temperature, T<sub>A</sub>. The junction-to-air thermal resistance, R<sub>θJA</sub>, in the table is that of a device installed on a high-K test board for leaded surface-mount packages. Use these equations to calculate the value for each parameter:  
 $T_J = T_A + R_{\theta JA} \times P$ , where P is the power dissipated in the device.  
 $T_{J(max)} = T_S = T_A + R_{\theta JA} \times P_S$ , where T<sub>J(max)</sub> is the maximum allowed junction temperature.  
 $P_S = I_S \times V_I$ , where V<sub>I</sub> is the maximum input voltage.



## 7.9 Electrical Characteristics: Driver

All typical specs are at  $V_{CC1}=3.3V$ ,  $V_{CC2}=5V$ ,  $T_A=27^\circ C$ , (Min/Max specs are over recommended operating conditions unless otherwise noted)

PARAMETER		TEST CONDITIONS	MIN	TYP	MAX	UNIT
V <sub>OD</sub>	Driver differential-output voltage magnitude	Open circuit voltage, unloaded bus, $3V \leq V_{CC2} \leq 5.5V$	1.5	5	$V_{CC2}$	V
		$R_L = 60\ \Omega$ , $-7V \leq V_{TEST} \leq 12V$ (see Figure 8-1), $3V \leq V_{CC2} \leq 3.6V$ , $T_A < 100^\circ C$	1.5	2.3		V
		$R_L = 60\ \Omega$ , $-7V \leq V_{TEST} \leq 12V$ (see Figure 8-1), $3.1V \leq V_{CC2} \leq 3.6V$ , $T_A > 100^\circ C$	1.5	2.3		
		$R_L = 60\ \Omega$ , $-7V \leq V_{TEST} \leq 12V$ , $4.5V < V_{CC2} < 5.5V$ (see Figure 8-1)	2.1	3.7		V
		$R_L = 100\ \Omega$ (see Figure 8-2), RS-422 load	2	4.2		V
		$R_L = 54\ \Omega$ (see Figure 8-2), RS-485 load, $V_{CC2} = 3V$ to $3.6V$	1.5	2.3		V
		$R_L = 54\ \Omega$ (see Figure 8-2), RS-485 load, $4.5V < V_{CC2} < 5.5V$	2.1	3.7		V
$\Delta V_{OD} $	Change in differential output voltage between two states	$R_L = 54\ \Omega$ or $R_L = 100\ \Omega$ , see Figure 8-2	-200		200	mV
V <sub>OC</sub>	Common-mode output voltage	$R_L = 54\ \Omega$ or $R_L = 100\ \Omega$ , see Figure 8-2	1	$0.5 \times V_{CC2}$	3	V
$\Delta V_{OC(SS)}$	change in steady-state common-mode output voltage between two states	$R_L = 54\ \Omega$ or $R_L = 100\ \Omega$ , see Figure 8-2	-200		200	mV
I <sub>OS</sub>	Short-circuit output current	$V_D = V_{CC1}$ or $V_D = V_{GND1}$ , $V_{DE} = V_{CC1}$ , $V_{CC2} = 3.3V \pm 10\%$ $-7V \leq V \leq 12V$ , see Figure 8-11	-250		250	mA
		$V_D = V_{CC1}$ or $V_D = V_{GND1}$ , $V_{DE} = V_{CC1}$ , $V_{CC2} = 5V \pm 10\%$ $-7V \leq V \leq 12V$ , see Figure 8-11		250		mA
I <sub>i</sub>	Input current	$V_D$ and $V_{DE} = 0V$ or $V_D$ and $V_{DE} = V_{CC1}$	-10		10	$\mu A$
CMTI	Common-mode transient immunity	$V_D = V_{CC1}$ or $GND1$ , $V_{CC1} = 1.71V$ to $5.5V$ , $V_{CM} = 1200V$ , ISO141x, See Figure 8-4	85	100		kV/ $\mu s$
CMTI	Common-mode transient immunity	$V_D = V_{CC1}$ or $GND1$ , $V_{CC1} = 1.71V$ to $5.5V$ , $V_{CM} = 1200V$ , ISO143x, See Figure 8-4	85	100		kV/ $\mu s$
CMTI	Common-mode transient immunity	$V_D = V_{CC1}$ or $GND1$ , $V_{CC1} = 2.25V$ to $5.5V$ , $V_{CM} = 1200V$ , ISO145x, See Figure 8-4	85	100		kV/ $\mu s$

## 7.10 Electrical Characteristics: Receiver

All typical specs are at  $V_{CC1}=3.3V$ ,  $V_{CC2}=5V$ ,  $T_A=27^\circ C$ , (Min/Max specs are over recommended operating conditions unless otherwise noted)

PARAMETER		TEST CONDITIONS	MIN	TYP	MAX	UNIT
$I_{I1}$	Bus input current	$V_{DE} = 0\text{ V}$ , $V_{CC2} = 0\text{ V}$ or $V_{CC2} = 5.5\text{ V}$ , 500-kbps devices, $V_I = -7\text{ V}$ or $V_I = 12\text{ V}$ , other input at 0 V	-100		125	$\mu\text{A}$
$I_{I1}$	Bus input current	$V_{DE} = 0\text{ V}$ , $V_{CC2} = 0\text{ V}$ or $V_{CC2} = 5.5\text{ V}$ , 12-Mbps and 50-Mbps devices, $V_I = -7\text{ V}$ or $V_I = 12\text{ V}$ , other input at 0 V	-100		125	$\mu\text{A}$
$I_{I1}$	Bus input current	$V_{DE} = 0\text{ V}$ , $V_{CC2} = 0\text{ V}$ or $V_{CC2} = 5.5\text{ V}$ , 500-kbps devices, $V_I = -15\text{ V}$ or $V_I = 15\text{ V}$ , other input at 0 V	-200		125	$\mu\text{A}$
$I_{I1}$	Bus input current	$V_{DE} = 0\text{ V}$ , $V_{CC2} = 0\text{ V}$ or $V_{CC2} = 5.5\text{ V}$ , 12-Mbps and 50-Mbps devices, $V_I = -15\text{ V}$ or $V_I = 15\text{ V}$ , other input at 0 V	-200		125	$\mu\text{A}$
$V_{TH+}$	Positive-going input threshold voltage	$-15\text{ V} \leq V_{CM} \leq 15\text{ V}$	See (1)	-100	-10	mV
		$-7\text{ V} \leq V_{CM} \leq 12\text{ V}$	See (1)	-100	-20	mV
$V_{TH-}$	Negative-going input threshold voltage	$-15\text{ V} \leq V_{CM} \leq 15\text{ V}$	-200	-130	See (1)	mV
$V_{hys}$	Input hysteresis ( $V_{TH+} - V_{TH-}$ )	$-15\text{ V} \leq V_{CM} \leq 15\text{ V}$		30		mV
$V_{OH}$	Output high voltage on the R pin	$V_{CC1}=5V \pm 10\%$ , $I_{OH} = -4\text{ mA}$ , $V_{ID} = 200\text{ mV}$	$V_{CC1} - 0.4$			V
		$V_{CC1}=3.3V \pm 10\%$ , $I_{OH} = -2\text{ mA}$ , $V_{ID} = 200\text{ mV}$	$V_{CC1} - 0.3$			V
		$V_{CC1}=2.5V \pm 10\%$ , $1.8V \pm 5\%$ , $I_{OH} = -1\text{ mA}$ , $V_{ID} = 200\text{ mV}$	$V_{CC1} - 0.2$			V
$V_{OL}$	Output low voltage on the R pin	$V_{CC1}=5V \pm 10\%$ , $I_{OL} = 4\text{ mA}$ , $V_{ID} = -200\text{ mV}$			0.4	V
		$V_{CC1}=3.3V \pm 10\%$ , $I_{OL} = 2\text{ mA}$ , $V_{ID} = -200\text{ mV}$			0.3	V
		$V_{CC1}=2.5V \pm 10\%$ , $1.8V \pm 5\%$ , $I_{OL} = 1\text{ mA}$ , $V_{ID} = -200\text{ mV}$			0.2	V
$I_{OZ}$	Output high-impedance current on the R pin	$V_R = 0\text{ V}$ or $V_R = V_{CC1}$ , $V_{RE} = V_{CC1}$	-1		1	$\mu\text{A}$
$I_i$	Input current on the $\overline{RE}$ pin	$V_{RE} = 0\text{ V}$ or $V_{RE} = V_{CC1}$	-10		10	$\mu\text{A}$
CMTI	Common-mode transient immunity	$V_{CC1}=1.71\text{ V}$ to $5.5\text{ V}$ , $V_{ID} = 1.5\text{ V}$ or $-1.5\text{ V}$ , $V_{CM} = 1200\text{ V}$ , ISO141x, See <a href="#">Figure 8-4</a>	85	100		kV/ $\mu\text{s}$
CMTI	Common-mode transient immunity	$V_{CC1}=1.71\text{ V}$ to $5.5\text{ V}$ , $V_{ID} = 1.5\text{ V}$ or $-1.5\text{ V}$ , $V_{CM} = 1200\text{ V}$ , ISO143x, See <a href="#">Figure 8-4</a>	85	100		kV/ $\mu\text{s}$
CMTI	Common-mode transient immunity	$V_{CC1}=2.25\text{ V}$ to $5.5\text{ V}$ , $V_{ID} = 1.5\text{ V}$ or $-1.5\text{ V}$ , $V_{CM} = 1200\text{ V}$ , ISO145x, See <a href="#">Figure 8-4</a>	85	100		kV/ $\mu\text{s}$

(1) Under any specific conditions,  $V_{TH+}$  is verified to be at least  $V_{hys}$  higher than  $V_{TH-}$ .

## 7.11 Supply Current Characteristics: Side 1 (I<sub>CC1</sub>)

Bus loaded or unloaded (over recommended operating conditions unless otherwise noted)

PARAMETER	TEST CONDITIONS	MIN	TYP	MAX	UNIT
<b>DRIVER ENABLED, RECEIVER DISABLED</b>					
Logic-side supply current	$V_D = V_{CC1}, V_{CC1} = 5\text{ V} \pm 10\%$		2.6	4.4	mA
Logic-side supply current	$V_D = V_{CC1}, V_{CC1} = 3.3\text{ V} \pm 10\%$		2.6	4.4	mA
Logic-side supply current	ISO141x, D = 500-kbps square wave with 50% duty cycle, $V_{CC1} = 5\text{ V} \pm 10\%$		3.2	5.1	mA
Logic-side supply current	ISO141x, D = 500-kbps square wave with 50% duty cycle, $V_{CC1} = 3.3\text{ V} \pm 10\%$		3.2	5.1	mA
Logic-side supply current	ISO143x, D = 12-Mbps square wave with 50% duty cycle, $V_{CC1} = 5\text{ V} \pm 10\%$		3.2	5.1	mA
Logic-side supply current	ISO143x, D = 12-Mbps square wave with 50% duty cycle, $V_{CC1} = 3.3\text{ V} \pm 10\%$		3.2	5.1	mA
Logic-side supply current	ISO145x, D = 50-Mbps square wave with 50% duty cycle, $V_{CC1} = 5\text{ V} \pm 10\%$		3.6	5.3	mA
Logic-side supply current	ISO145x, D = 50-Mbps square wave with 50% duty cycle, $V_{CC1} = 3.3\text{ V} \pm 10\%$		3.4	5.2	mA
<b>DRIVER ENABLED, RECEIVER ENABLED</b>					
Logic-side supply current	$V_{RE} = V_{GND1}$ , loopback if full-duplex device, $V_D = V_{CC1}, V_{CC1} = 5\text{ V} \pm 10\%$		2.6	4.4	mA
Logic-side supply current	$V_{RE} = V_{GND1}$ , loopback if full-duplex device, $V_D = V_{CC1}, V_{CC1} = 3.3\text{ V} \pm 10\%$		2.6	4.4	mA
Logic-side supply current	ISO141x, $V_{RE} = V_{GND1}$ , loopback if full-duplex device, D = 500-kbps square wave with 50% duty cycle, $V_{CC1} = 5\text{ V} \pm 10\%$ , $C_{L(R)}^{(1)} = 15\text{ pF}$		3.3	5.1	mA
Logic-side supply current	ISO141x, $V_{RE} = V_{GND1}$ , loopback if full-duplex device, D = 500-kbps square wave with 50% duty cycle, $V_{CC1} = 3.3\text{ V} \pm 10\%$ , $C_{L(R)}^{(1)} = 15\text{ pF}$		3.2	5.1	mA
Logic-side supply current	ISO143x, $V_{RE} = V_{GND1}$ , loopback if full-duplex device, D = 12-Mbps square wave with 50% duty cycle, $V_{CC1} = 5\text{ V} \pm 10\%$ , $C_{L(R)}^{(1)} = 15\text{ pF}$		4.1	6	mA
Logic-side supply current	ISO143x, $V_{RE} = V_{GND1}$ , loopback if full-duplex device, D = 12-Mbps square wave with 50% duty cycle, $V_{CC1} = 3.3\text{ V} \pm 10\%$ , $C_{L(R)}^{(1)} = 15\text{ pF}$		3.8	5.7	mA
Logic-side supply current	ISO145x, $V_{RE} = V_{GND1}$ , loopback if full-duplex device, D = 50-Mbps square wave with 50% duty cycle, $V_{CC1} = 5\text{ V} \pm 10\%$ , $C_{L(R)}^{(1)} = 15\text{ pF}$		6.3	8.9	mA
Logic-side supply current	ISO145x, $V_{RE} = V_{GND1}$ , loopback if full-duplex device, D = 50-Mbps square wave with 50% duty cycle, $V_{CC1} = 3.3\text{ V} \pm 10\%$ , $C_{L(R)}^{(1)} = 15\text{ pF}$		5.3	7.8	mA
<b>DRIVER DISABLED, RECEIVER ENABLED</b>					
Logic-side supply current	$V_{(A-B)} \geq 200\text{ mV}, V_D = V_{CC1}, V_{CC1} = 5\text{ V} \pm 10\%$		1.6	3.1	mA
Logic-side supply current	$V_{(A-B)} \geq 200\text{ mV}, V_D = V_{CC1}, V_{CC1} = 3.3\text{ V} \pm 10\%$		1.6	3.1	mA
Logic-side supply current	ISO141x, (A-B) = 500-kbps square wave with 50% duty cycle, $V_D = V_{CC1}, V_{CC1} = 5\text{ V} \pm 10\%$ , $C_{L(R)}^{(1)} = 15\text{ pF}$		1.7	3.1	mA
Logic-side supply current	ISO141x, (A-B) = 500-kbps square wave with 50% duty cycle, $V_D = V_{CC1}, V_{CC1} = 3.3\text{ V} \pm 10\%$ , $C_{L(R)}^{(1)} = 15\text{ pF}$		1.6	3.1	mA
Logic-side supply current	ISO143x, (A-B) = 12-Mbps square wave with 50% duty cycle, $V_D = V_{CC1}, V_{CC1} = 5\text{ V} \pm 10\%$ , $C_{L(R)}^{(1)} = 15\text{ pF}$		2.6	4	mA
Logic-side supply current	ISO143x, (A-B) = 12-Mbps square wave with 50% duty cycle, $V_D = V_{CC1}, V_{CC1} = 3.3\text{ V} \pm 10\%$ , $C_{L(R)}^{(1)} = 15\text{ pF}$		2.2	3.7	mA
Logic-side supply current	ISO145x, (A-B) = 50-Mbps square wave with 50% duty cycle, $V_D = V_{CC1}, V_{CC1} = 5\text{ V} \pm 10\%$ , $C_{L(R)}^{(1)} = 15\text{ pF}$		4.7	6.7	mA
Logic-side supply current	ISO145x, (A-B) = 50-Mbps square wave with 50% duty cycle, $V_D = V_{CC1}, V_{CC1} = 3.3\text{ V} \pm 10\%$ , $C_{L(R)}^{(1)} = 15\text{ pF}$		3.7	5.7	mA
<b>DRIVER DISABLED, RECEIVER DISABLED</b>					
Logic-side supply current	$V_{DE} = V_{GND1}, V_D = V_{CC1}, V_{CC1} = 5\text{ V} \pm 10\%$		1.6	3.1	mA

Bus loaded or unloaded (over recommended operating conditions unless otherwise noted)

PARAMETER	TEST CONDITIONS	MIN	TYP	MAX	UNIT
Logic-side supply current	$V_{DE} = V_{GND1}$ , $V_D = V_{CC1}$ , $V_{CC1} = 3.3\text{ V} \pm 10\%$		1.6	3.1	mA

(1)  $C_{L(R)}$  is the load capacitance on the R pin.

## 7.12 Supply Current Characteristics: Side 2 ( $I_{CC2}$ )

$V_{RE} = V_{GND1}$  or  $V_{RE} = V_{CC1}$  (over recommended operating conditions unless otherwise noted)

PARAMETER	TEST CONDITIONS	MIN	TYP	MAX	UNIT
<b>DRIVER ENABLED, BUS UNLOADED</b>					
Bus-side supply current	$V_D = V_{CC1}$ , $V_{CC2} = 3.3\text{ V} \pm 10\%$		4	6.1	mA
Bus-side supply current	$V_D = V_{CC1}$ , $V_{CC2} = 5\text{ V} \pm 10\%$		4.5	6.6	mA
<b>DRIVER ENABLED, BUS LOADED</b>					
Bus-side supply current	$V_D = V_{CC1}$ , $R_L = 54\ \Omega$ , $V_{CC2} = 3.3\text{ V} \pm 10\%$		48	58	mA
Bus-side supply current	$V_D = V_{CC1}$ , $R_L = 54\ \Omega$ , $V_{CC2} = 5\text{ V} \pm 10\%$		74	88	mA
Bus-side supply current	ISO141x, D = 500-kbps square wave with 50% duty cycle, $R_L = 54\ \Omega$ , $C_L = 50\text{ pF}$ , $V_{CC2} = 3.3\text{ V} \pm 10\%$		63	95	mA
Bus-side supply current	ISO141x, D = 500-kbps square wave with 50% duty cycle, $R_L = 54\ \Omega$ , $C_L = 50\text{ pF}$ , $V_{CC2} = 5\text{ V} \pm 10\%$		113	160	mA
Bus-side supply current	ISO143x, D = 12-Mbps square wave with 50% duty cycle, $R_L = 54\ \Omega$ , $C_L = 50\text{ pF}$ , $V_{CC2} = 3.3\text{ V} \pm 10\%$		56	75	mA
Bus-side supply current	ISO143x, D = 12-Mbps square wave with 50% duty cycle, $R_L = 54\ \Omega$ , $C_L = 50\text{ pF}$ , $V_{CC2} = 5\text{ V} \pm 10\%$		97	122	mA
Bus-side supply current	ISO145x, D = 50-Mbps square wave with 50% duty cycle, $R_L = 54\ \Omega$ , $C_L = 50\text{ pF}$ , $V_{CC2} = 3.3\text{ V} \pm 10\%$		84	103	mA
Bus-side supply current	ISO145x, D = 50-Mbps square wave with 50% duty cycle, $R_L = 54\ \Omega$ , $C_L = 50\text{ pF}$ , $V_{CC2} = 5\text{ V} \pm 10\%$		134	162	mA
<b>DRIVER DISABLED, BUS LOADED OR UNLOADED</b>					
Bus-side supply current	$V_D = V_{CC1}$ , $V_{CC2} = 3.3\text{ V} \pm 10\%$		2.6	4.3	mA
Bus-side supply current	$V_D = V_{CC1}$ , $V_{CC2} = 5\text{ V} \pm 10\%$		2.8	4.5	mA

### 7.13 Switching Characteristics: Driver

All typical specs are at  $V_{CC1}=3.3V$ ,  $V_{CC2}=5V$ ,  $T_A=27^{\circ}C$ , (Min/Max specs are over recommended operating conditions unless otherwise noted)

PARAMETER		TEST CONDITIONS	MIN	TYP	MAX	UNIT
<b>500-kbps DEVICES</b>						
$t_r, t_f$	Differential output rise time and fall time	$R_L = 54 \Omega$ , $C_L = 50 \text{ pF}$ , see <a href="#">Figure 8-3</a>	240	460	680	ns
$t_{PHL}, t_{PLH}$	Propagation delay	$R_L = 54 \Omega$ , $C_L = 50 \text{ pF}$ , see <a href="#">Figure 8-3</a>		310	570	ns
PWD	Pulse width distortion <sup>(1)</sup> , $ t_{PHL} - t_{PLH} $	$R_L = 54 \Omega$ , $C_L = 50 \text{ pF}$ , see <a href="#">Figure 8-3</a>		4	50	ns
$t_{PHZ}, t_{PLZ}$	Disable time	See <a href="#">Figure 8-6</a> , and <a href="#">Figure 8-7</a>		125	200	ns
$t_{PZH}, t_{PZL}$	Enable time	See <a href="#">Figure 8-6</a> , and <a href="#">Figure 8-7</a>		160	600	ns
<b>12-Mbps DEVICES</b>						
$t_r, t_f$	Differential output rise time and fall time	$R_L = 54 \Omega$ , $C_L = 50 \text{ pF}$ , $V_{CC2} = 4.5 \text{ V to } 5.5 \text{ V}$ , see <a href="#">Figure 8-3</a>		10	25	ns
		$R_L = 54 \Omega$ , $C_L = 50 \text{ pF}$ , $V_{CC2} = 3 \text{ V to } 3.6 \text{ V}$ , see <a href="#">Figure 8-3</a>			27.8	ns
$t_{PHL}, t_{PLH}$	Propagation delay	$R_L = 54 \Omega$ , $C_L = 50 \text{ pF}$ , see <a href="#">Figure 8-3</a>		68	125	ns
PWD	Pulse width distortion <sup>(1)</sup> , $ t_{PHL} - t_{PLH} $	$R_L = 54 \Omega$ , $C_L = 50 \text{ pF}$ , see <a href="#">Figure 8-3</a>		2	10	ns
$t_{PHZ}, t_{PLZ}$	Disable time	See <a href="#">Figure 8-6</a> , and <a href="#">Figure 8-7</a>		75	125	ns
$t_{PZH}, t_{PZL}$	Enable time	See <a href="#">Figure 8-6</a> , and <a href="#">Figure 8-7</a>		75	160	ns
<b>50-Mbps DEVICES</b>						
$t_r, t_f$	Differential output rise time and fall time	$R_L = 54 \Omega$ , $C_L = 50 \text{ pF}$ , $V_{CC2} = 4.5 \text{ V to } 5.5 \text{ V}$ , see <a href="#">Figure 8-3</a>		4.7	6	ns
		$R_L = 54 \Omega$ , $C_L = 50 \text{ pF}$ , $V_{CC2} = 3 \text{ V to } 3.6 \text{ V}$ , see <a href="#">Figure 8-3</a>			7.8	ns
$t_{PHL}, t_{PLH}$	Propagation delay	$R_L = 54 \Omega$ , $C_L = 50 \text{ pF}$ , see <a href="#">Figure 8-3</a>		19	41	ns
PWD	Pulse width distortion <sup>(1)</sup> , $ t_{PHL} - t_{PLH} $	$R_L = 54 \Omega$ , $C_L = 50 \text{ pF}$ , see <a href="#">Figure 8-3</a>		1	6	ns
$t_{PHZ}, t_{PLZ}$	Disable time	See <a href="#">Figure 8-6</a> , and <a href="#">Figure 8-7</a>		25	46	ns
$t_{PZH}, t_{PZL}$	Enable time	See <a href="#">Figure 8-6</a> , and <a href="#">Figure 8-7</a>		32	78	ns

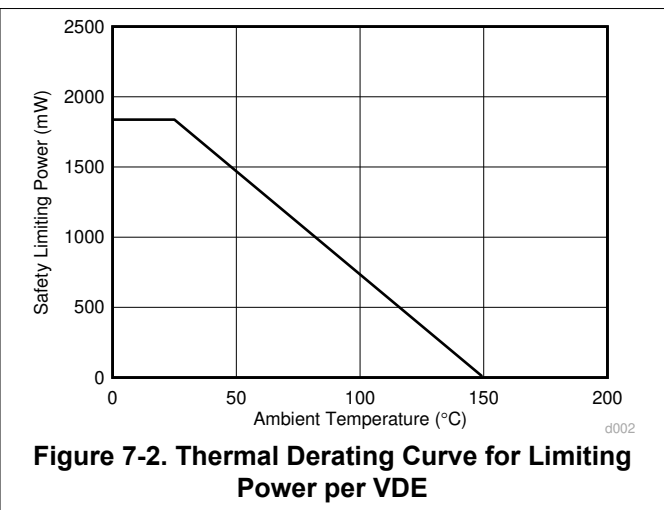
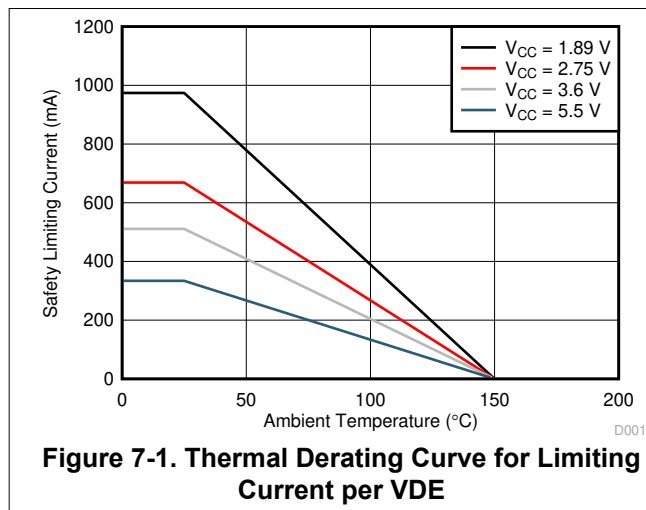
(1) Also known as pulse skew.

## 7.14 Switching Characteristics: Receiver

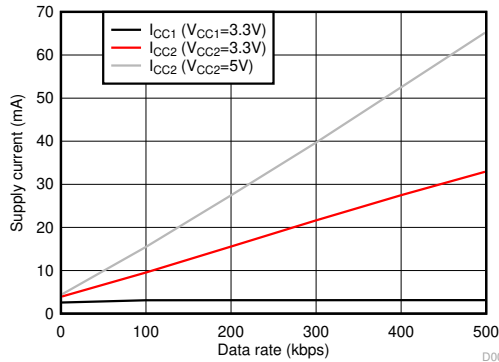
All typical specs are at  $V_{CC1}=3.3V$ ,  $V_{CC2}=5V$ ,  $T_A=27^{\circ}C$ , (Min/Max specs are over recommended operating conditions unless otherwise noted)

PARAMETER		TEST CONDITIONS	MIN	TYP	MAX	UNIT
<b>500-kbps DEVICES</b>						
$t_r, t_f$	Differential output rise time and fall time	$C_L = 15$ pF, see <a href="#">Figure 8-8</a>		1	4	ns
$t_{PHL}, t_{PLH}$	Propagation delay	$C_L = 15$ pF, see <a href="#">Figure 8-8</a>		92	135	ns
PWD	Pulse width distortion <sup>(1)</sup> , $ t_{PHL} - t_{PLH} $	$C_L = 15$ pF, see <a href="#">Figure 8-8</a>		4.5	12.5	ns
$t_{PHZ}, t_{PLZ}$	Disable time	See <a href="#">Figure 8-9</a> and <a href="#">Figure 8-10</a>		9	30	ns
$t_{PZH}, t_{PZL}$	Enable time	See <a href="#">Figure 8-9</a> and <a href="#">Figure 8-10</a>		5	20	ns
<b>12-Mbps DEVICES</b>						
$t_r, t_f$	Differential output rise time and fall time	$C_L = 15$ pF, see <a href="#">Figure 8-8</a>		1	4	ns
$t_{PHL}, t_{PLH}$	Propagation delay	$C_L = 15$ pF, see <a href="#">Figure 8-8</a>		75	120	ns
PWD	Pulse width distortion <sup>(1)</sup> , $ t_{PHL} - t_{PLH} $	$C_L = 15$ pF, see <a href="#">Figure 8-8</a>		1	10	ns
$t_{PHZ}, t_{PLZ}$	Disable time	See <a href="#">Figure 8-9</a> and <a href="#">Figure 8-10</a>		9	30	ns
$t_{PZH}, t_{PZL}$	Enable time	See <a href="#">Figure 8-9</a> and <a href="#">Figure 8-10</a>		5	20	ns
<b>50-Mbps DEVICES</b>						
$t_r, t_f$	Differential output rise time and fall time	$C_L = 15$ pF, see <a href="#">Figure 8-8</a>		1	4	ns
$t_{PHL}, t_{PLH}$	Propagation delay	$C_L = 15$ pF, see <a href="#">Figure 8-8</a>		36	60	ns
PWD	Pulse width distortion <sup>(1)</sup> , $ t_{PHL} - t_{PLH} $	$C_L = 15$ pF, Measured with 50kHz, 50% Duty Clock, see <a href="#">Figure 8-8</a>		2	6	ns
$t_{PHZ}, t_{PLZ}$	Disable time	See <a href="#">Figure 8-9</a> and <a href="#">Figure 8-10</a>		9	30	ns
$t_{PZH}, t_{PZL}$	Enable time	See <a href="#">Figure 8-9</a> and <a href="#">Figure 8-10</a>		5	20	ns

## 7.15 Insulation Characteristics Curves

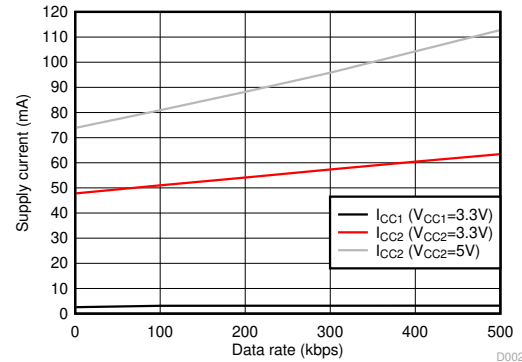


## 7.16 Typical Characteristics



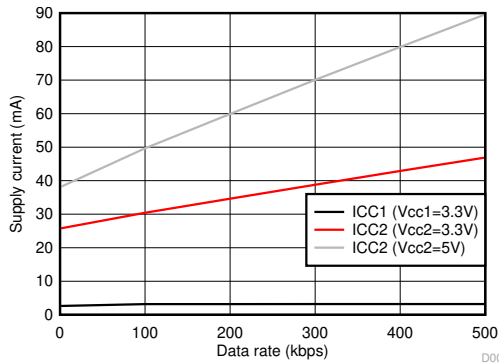
DE = V<sub>CC1</sub>     $\overline{RE}$  = GND1    T<sub>A</sub> = 25°C

**Figure 7-3. ISO141x Supply Current Vs Data Rate - No Load**



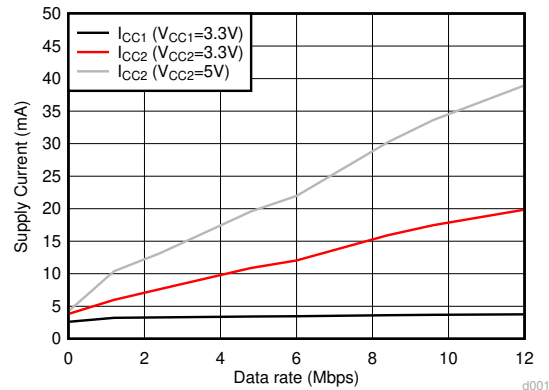
DE = V<sub>CC1</sub>     $\overline{RE}$  = GND1    Driver Load = 54 Ω || 50pF  
T<sub>A</sub> = 25°C    Load On R = 15 pF

**Figure 7-4. ISO141x Supply Current Vs Data Rate - With 54Ω||50pF Load**



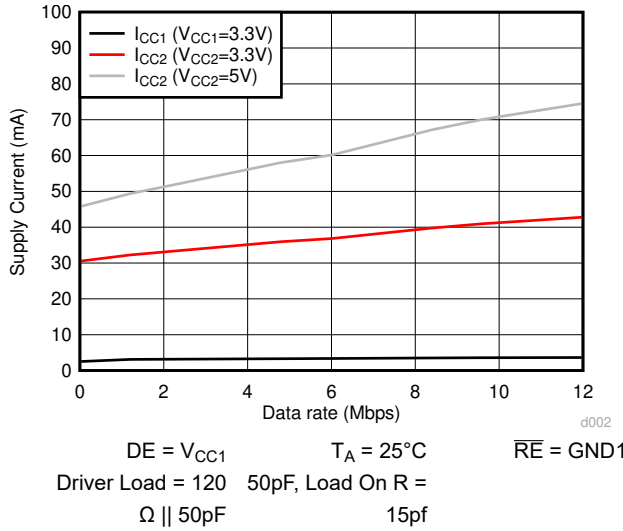
DE = V<sub>CC1</sub>     $\overline{RE}$  = GND1    Driver Load = 120 Ω || 50pF  
T<sub>A</sub> = 25°C    Load On R = 15 pF

**Figure 7-5. ISO141x Supply Current Vs Data Rate - With 120Ω||50pF Load**

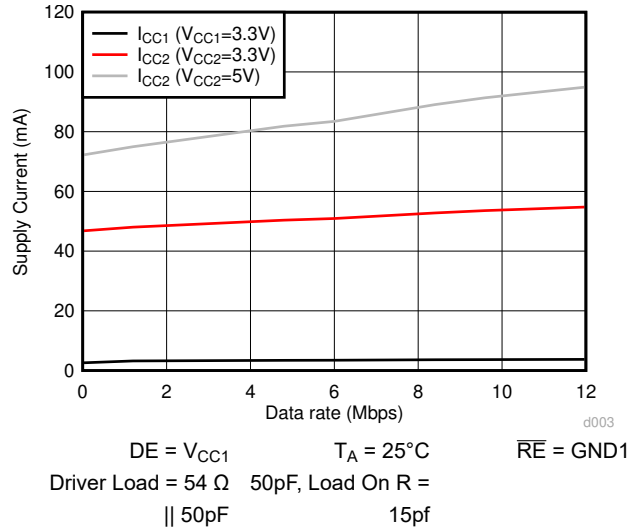


DE = V<sub>CC1</sub>    T<sub>A</sub> = 25°C     $\overline{RE}$  = GND1

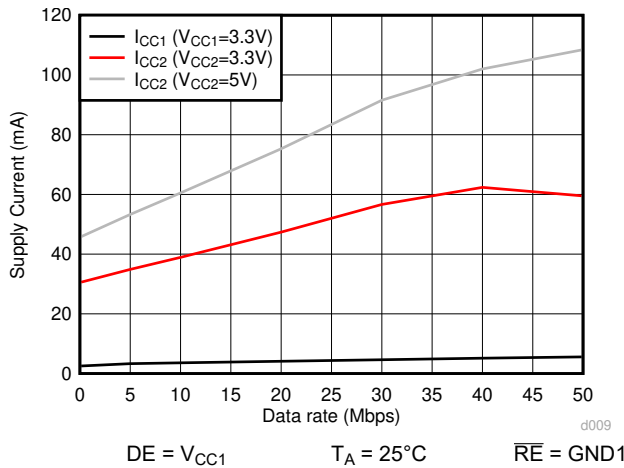
**Figure 7-6. ISO143x Supply Current Vs. Data Rate - No Load**



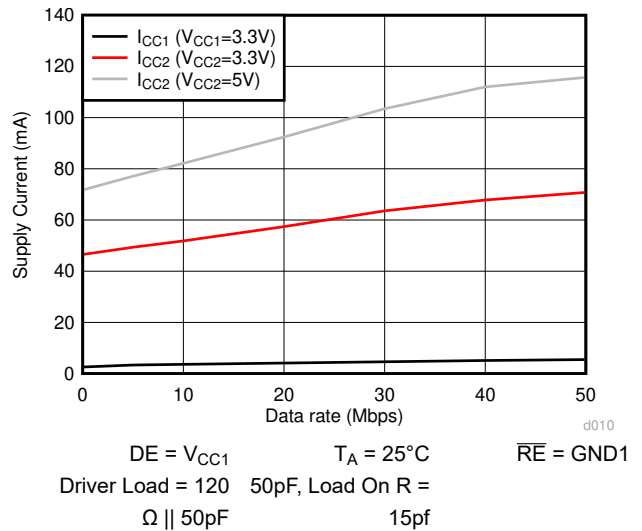
**Figure 7-7. ISO143x Supply Current Vs. Data Rate - 120 $\Omega$ ||50pF Load**



**Figure 7-8. ISO143x Supply Current Vs Data Rate- 54 $\Omega$ ||50pF Load**

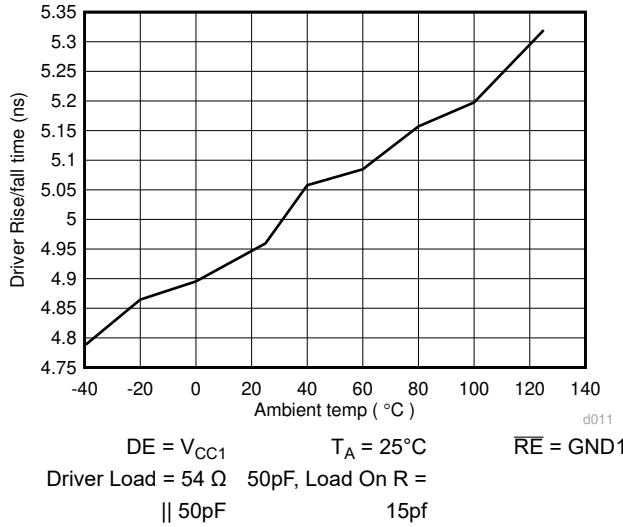


**Figure 7-9. ISO145x Supply Current Vs Data Rate- No Load**

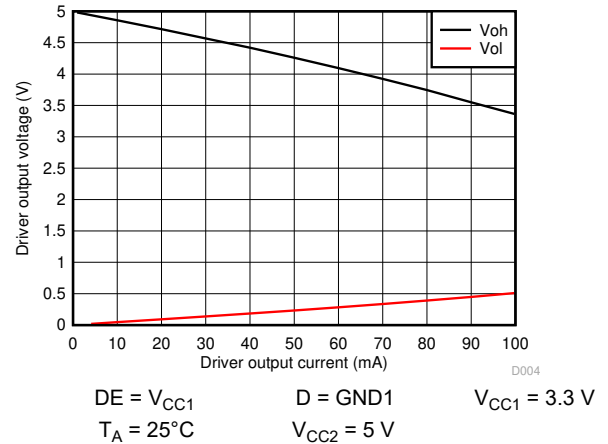


**Figure 7-10. ISO145x Supply Current Vs Data Rate- 120 $\Omega$ ||50pF Load**

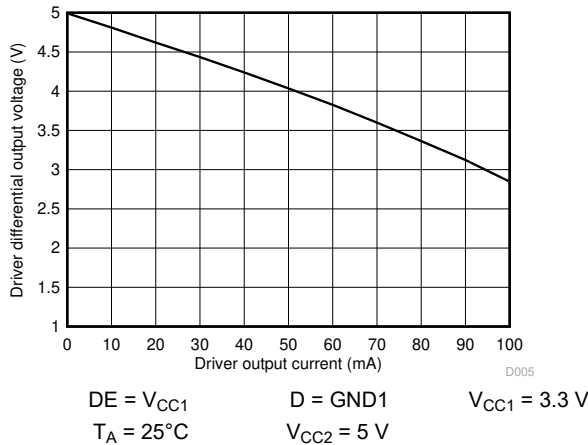




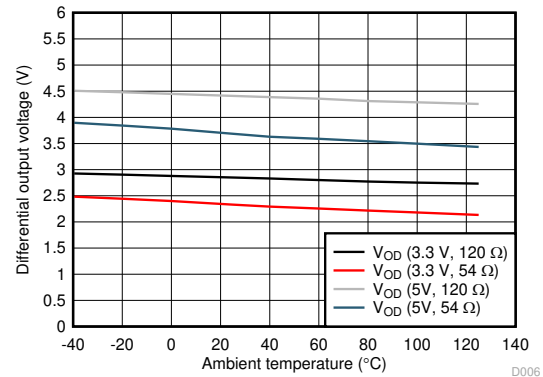
**Figure 7-11. ISO145x Supply Current Vs Data Rate-54Ω||50pF Load**



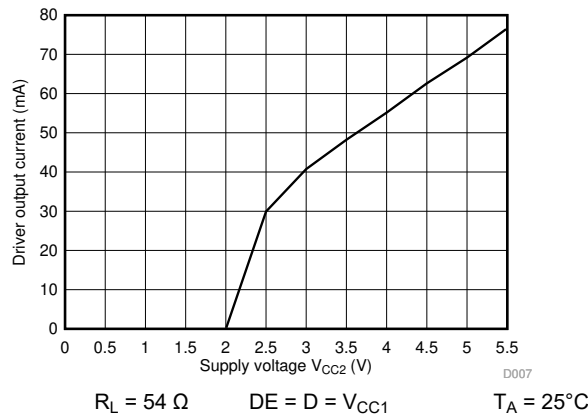
**Figure 7-12. Driver Output Voltage Vs Driver Output Current**



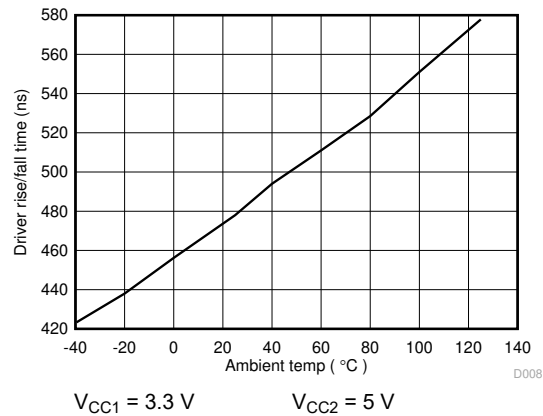
**Figure 7-13. Driver Differential Output Voltage Vs Driver Output Current**



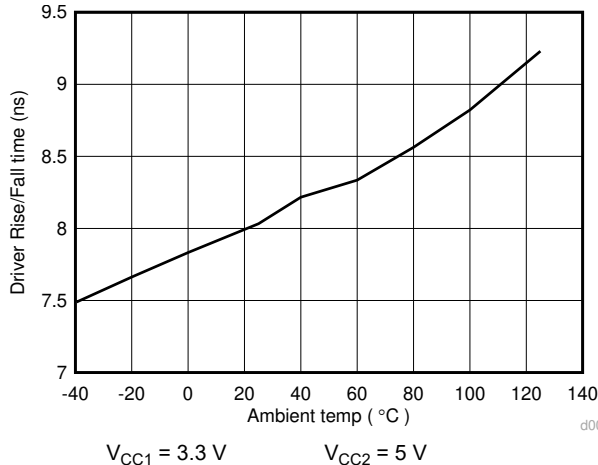
**Figure 7-14. Driver Differential Output Voltage Vs Temperature**



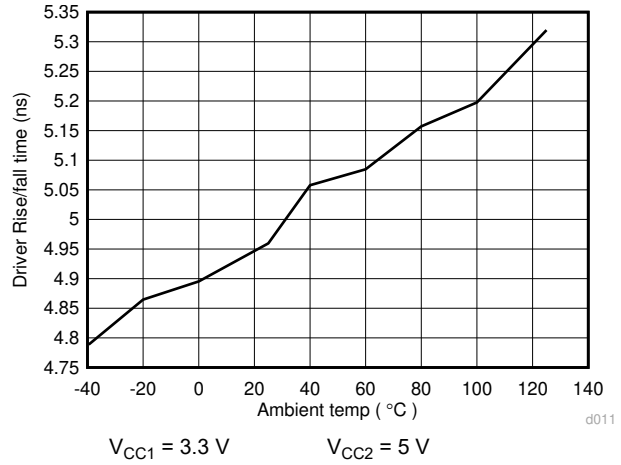
**Figure 7-15. Driver Output Current Vs Supply Voltage (V<sub>CC2</sub>)**



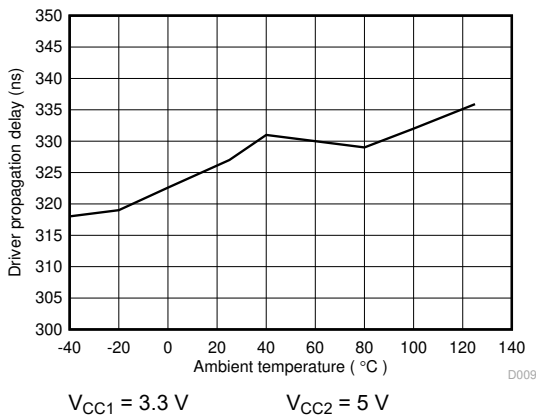
**Figure 7-16. ISO141x Driver Rise/fall Time (ns) Vs Temperature (c)**



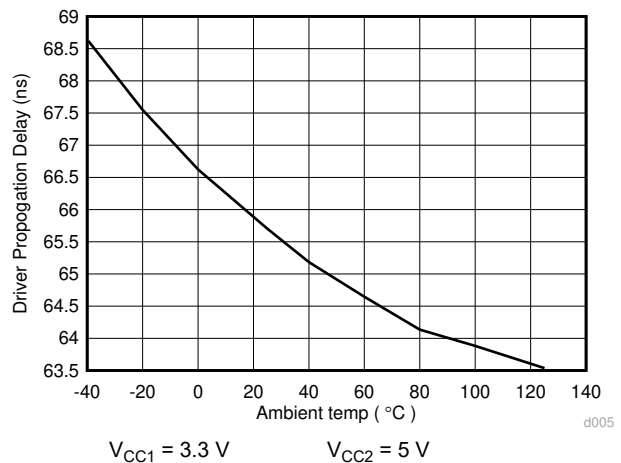
**Figure 7-17. ISO143x Driver Rise/Fall Time (ns) Vs Temperature (C)**



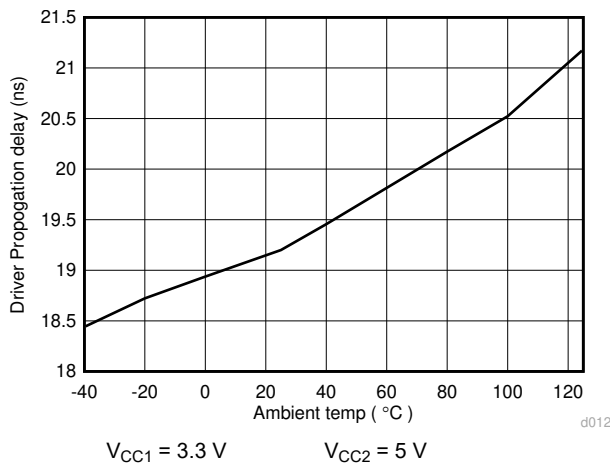
**Figure 7-18. ISO145x Driver Rise/Fall Time (ns) Vs Temperature (C)**



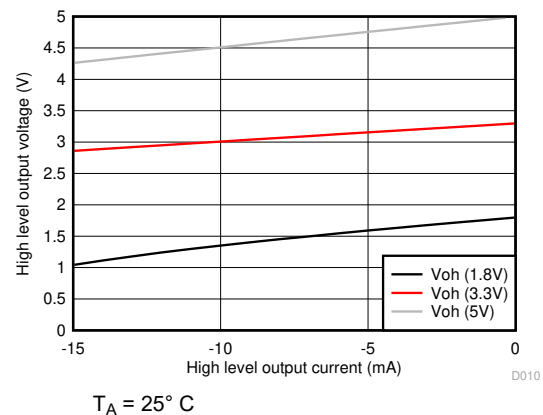
**Figure 7-19. ISO141x Driver Propagation Delay (ns) Vs Temperature (c)**



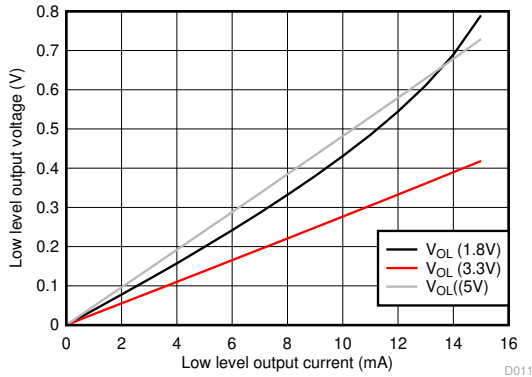
**Figure 7-20. ISO143x Driver Propagation Delay (ns) Vs Temperature (C)**



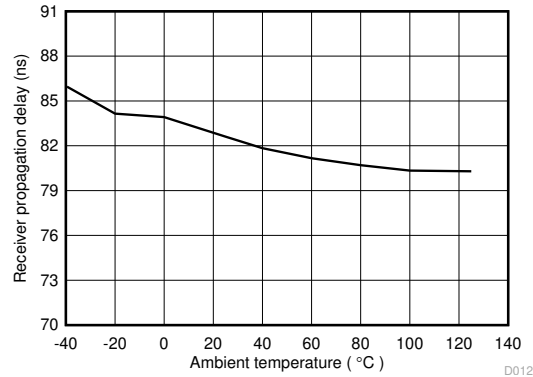
**Figure 7-21. ISO145x Driver Propagation Delay (ns) Vs Temperature (C)**



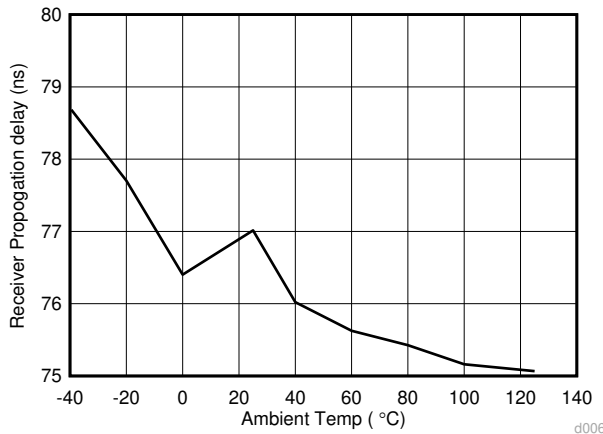
**Figure 7-22. Receiver Buffer High Level Output Voltage Vs High Level Output Current**



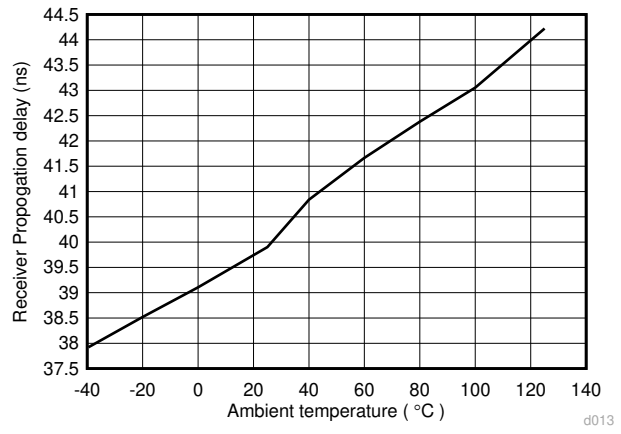
**Figure 7-23. Receiver Buffer Low Level Output Voltage Vs Low Level Output Current**



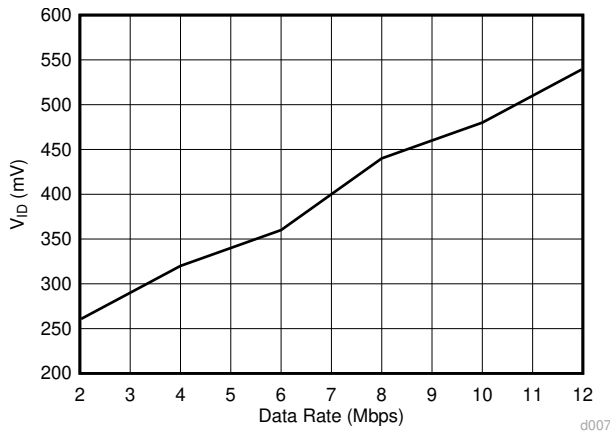
**Figure 7-24. ISO141x Receiver Propagation Delay (ns) Vs Temperature (c)**



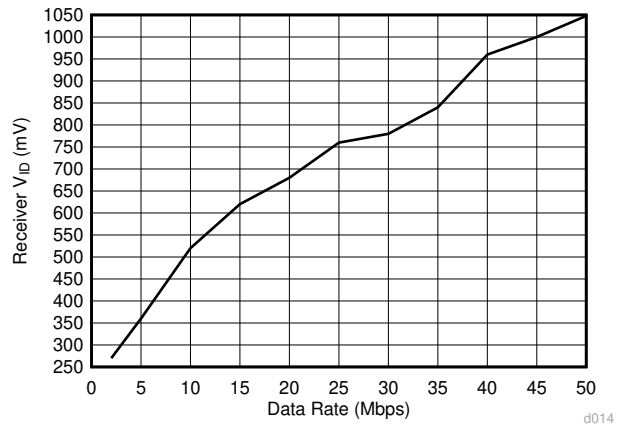
**Figure 7-25. ISO143x Receiver Propagation Delay (ns) Vs. Temperature (C)**



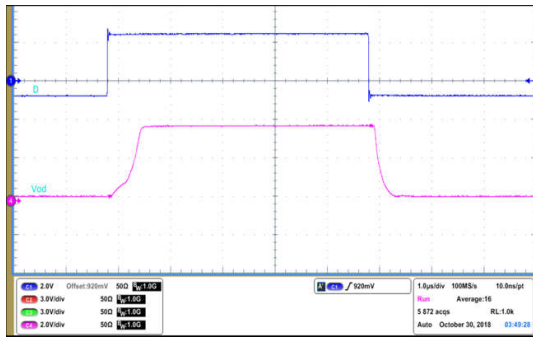
**Figure 7-26. ISO145x Receiver Propagation Delay (ns) Vs. Temperature (C)**



**Figure 7-27. ISO143x Receiver V<sub>ID</sub> vs Signaling Rate**

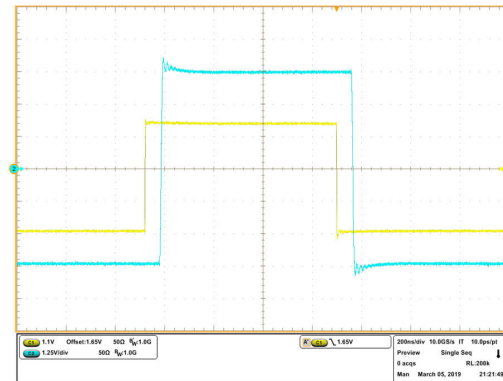


**Figure 7-28. ISO145x Receiver V<sub>ID</sub> vs Signaling Rate**



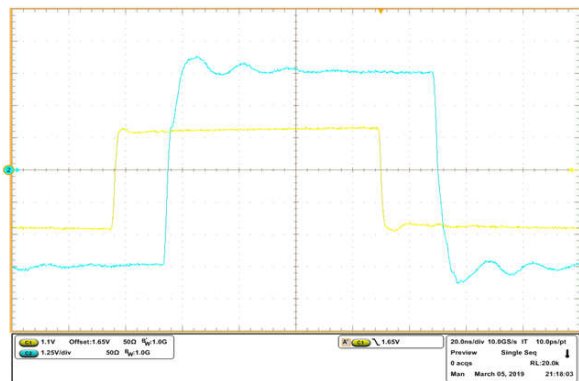
$V_{CC1} = 3.3\text{ V}$        $V_{CC2} = 5\text{ V}$        $T_A = 25^\circ\text{ C}$   
 $DE = V_{CC1}$

**Figure 7-29. ISO141x Driver Propagation Delay**



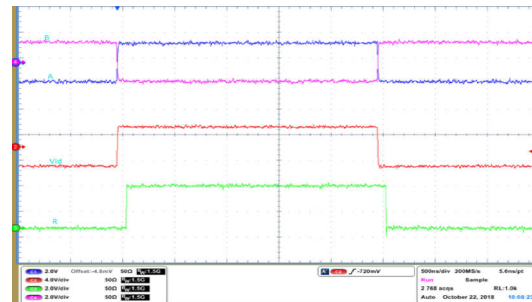
$V_{CC1} = 3.3\text{ V}$        $V_{CC2} = 5\text{ V}$        $T_A = 25^\circ\text{ C}$   
 $DE = V_{CC1}$

**Figure 7-30. ISO143x Driver Propagation Delay**



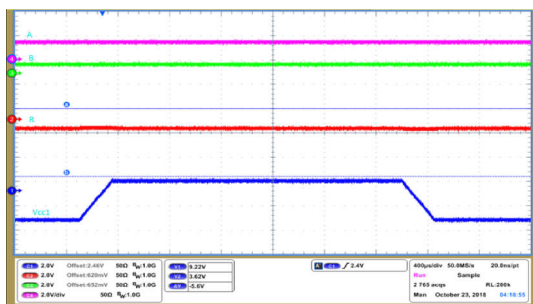
$V_{CC1} = 3.3\text{ V}$        $V_{CC2} = 5\text{ V}$        $T_A = 25^\circ\text{ C}$   
 $DE = V_{CC1}$

**Figure 7-31. ISO145x Driver Propagation Delay**

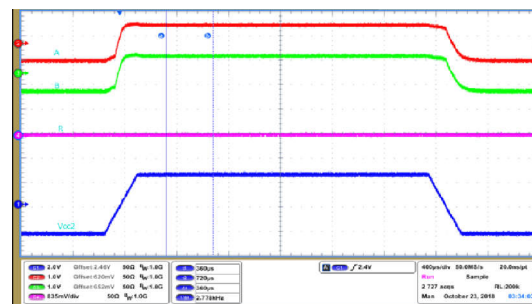


$V_{CC1} = 3.3\text{ V}$        $V_{CC2} = 5\text{ V}$        $T_A = 25^\circ\text{ C}$   
 $DE = \text{GND1}$        $RE = \text{GND1}$

**Figure 7-32. ISO141x Receiver Propagation Delay**



**Figure 7-33.  $V_{CC1}$  Power Up/Power Down - Glitch Free Behavior**



**Figure 7-34.  $V_{CC2}$  Power Up/Power Down - Glitch Free Behavior**

## 8 Parameter Measurement Information

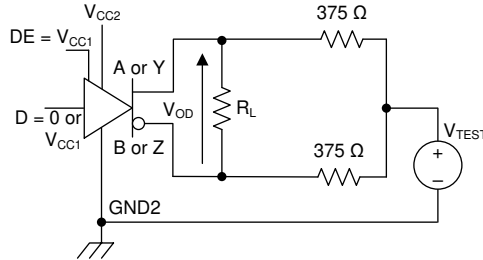
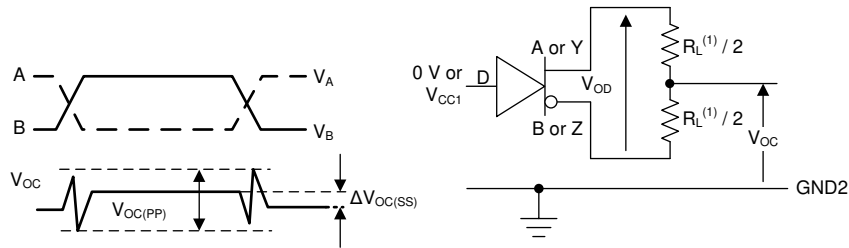
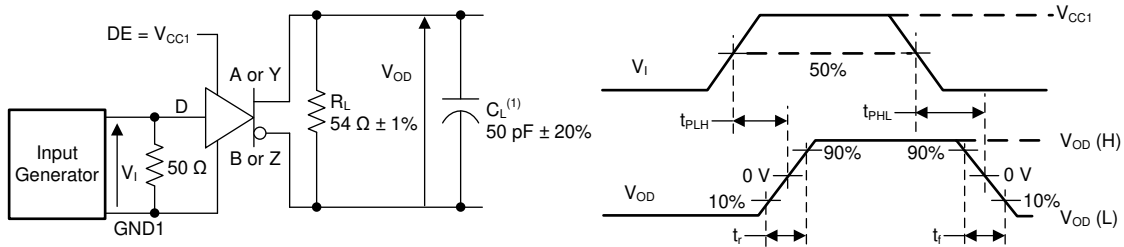


Figure 8-1. Driver Voltages



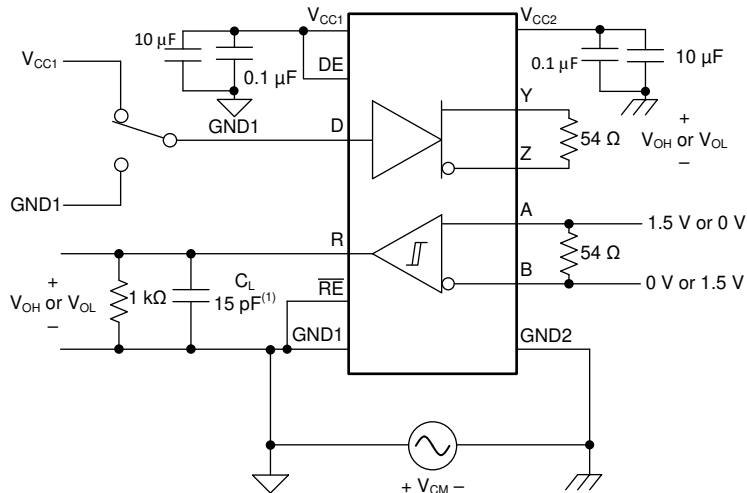
A.  $R_L = 100 \Omega$  for RS422,  $R_L = 54 \Omega$  for RS-485

Figure 8-2. Driver Voltages



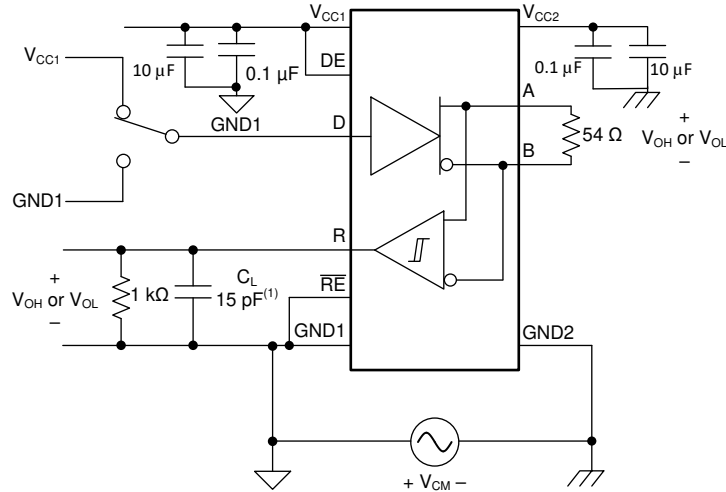
A.  $C_L$  includes fixture and instrumentation capacitance.

Figure 8-3. Driver Switching Specifications



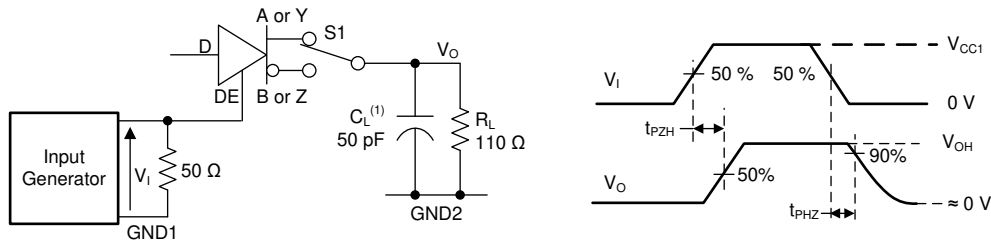
A. Includes probe and fixture capacitance.

Figure 8-4. Common Mode Transient Immunity (CMTI)—Full Duplex



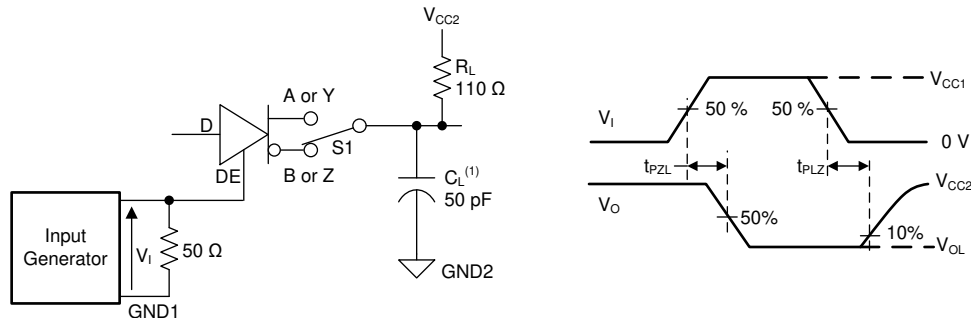
A. Includes probe and fixture capacitance.

**Figure 8-5. Common Mode Transient Immunity (CMTI)—Half Duplex**

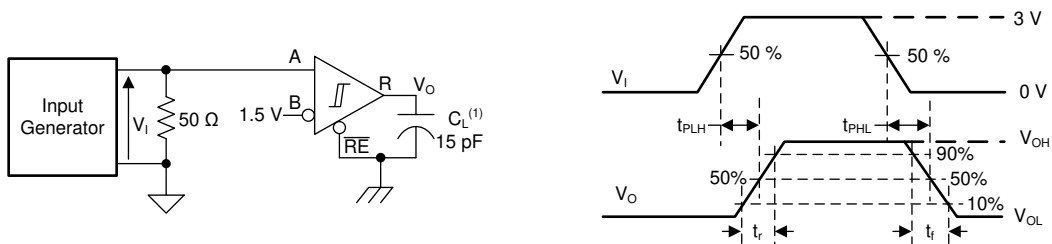


A.  $C_L$  includes fixture and instrumentation capacitance

**Figure 8-6. Driver Enable and Disable Times**



**Figure 8-7. Driver Enable and Disable Times**



A.  $C_L$  includes fixture and instrumentation capacitance.

**Figure 8-8. Receiver Switching Specifications**

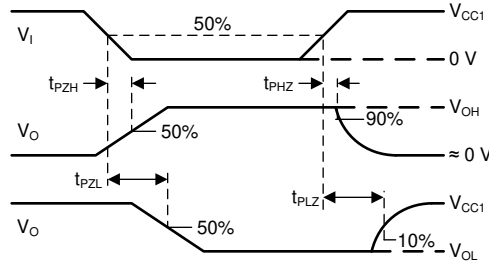


Figure 8-9. Receiver Enable and Disable Times

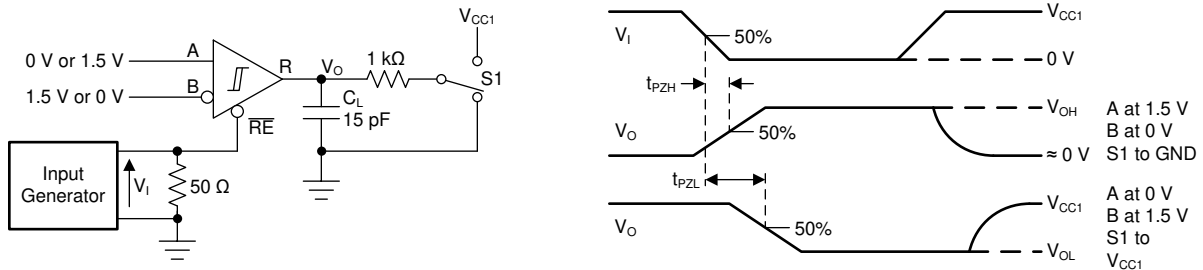
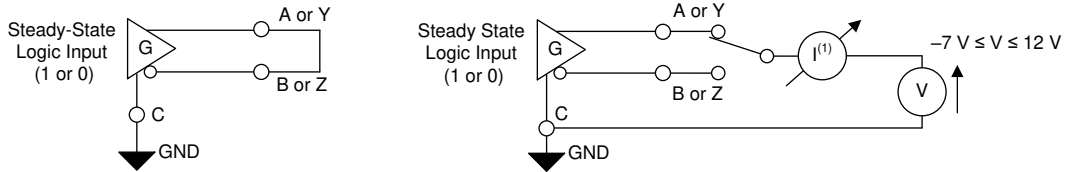


Figure 8-10. Receiver Enable and Disable Times



A. The driver should not sustain any damage with this configuration.

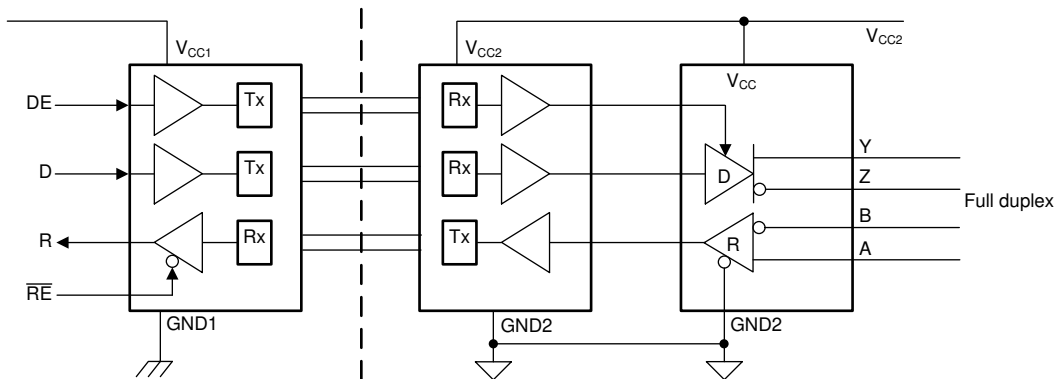
Figure 8-11. Short-Circuit Current Limiting

## 9 Detailed Description

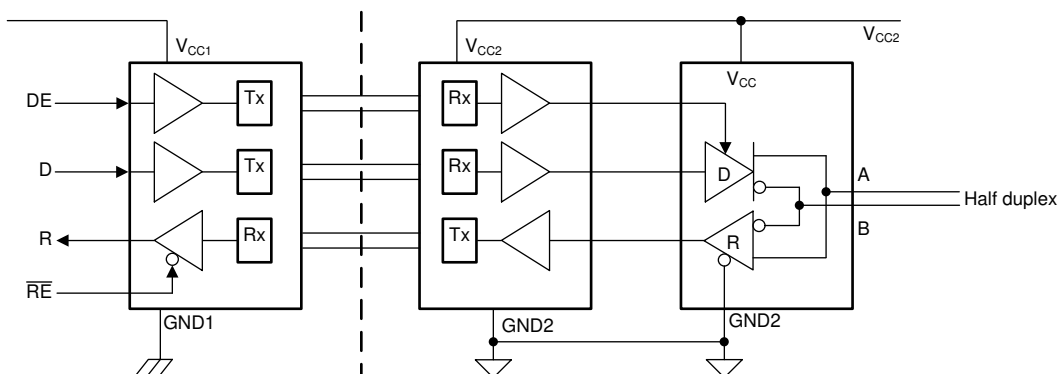
### 9.1 Overview

The ISO14xx devices are isolated RS-485/RS-422 transceivers designed to operate in harsh industrial environments. ISO141x, ISO143x and ISO145x devices support up to 500 kbps, 12 Mbps and 50 Mbps signaling rates respectively. This family of devices has a 3-channel digital isolator and an RS-485 transceiver in a 16-pin wide-body SOIC package. The silicon-dioxide based capacitive isolation barrier supports an isolation withstand voltage of 5 kV<sub>RMS</sub> and an isolation working voltage of 1500 V<sub>PK</sub>. Isolation breaks the ground loop between the communicating nodes and allows for data transfer in the presence of large ground potential differences. These devices have a higher typical differential output voltage ( $V_{OD}$ ) than traditional transceivers for better noise immunity. A minimum differential output voltage of 2.1 V is specified at a  $V_{CC2}$  voltage of 5 V  $\pm$ 10% which meets the requirements for Profibus applications. The wide logic supply of the device ( $V_{CC1}$ ) supports interfacing with 1.8-V, 2.5-V, 3.3-V, and 5-V control logic. The 3-V to 5.5-V bus side supply ( $V_{CC2}$ ) removes the need of a well-regulated isolated supply in end systems. [Figure 9-1](#) shows the functional block diagram of the full-duplex devices and [Figure 9-2](#) shows the functional block diagram of a half-duplex devices.

### 9.2 Functional Block Diagram



**Figure 9-1. Full-Duplex Block Diagram**



**Figure 9-2. Half-Duplex Block Diagram**



## 9.3 Feature Description

### 9.3.1 Electromagnetic Compatibility (EMC) Considerations

Many applications in harsh industrial environment are sensitive to disturbances such as electrostatic discharge (ESD), electrical fast transient (EFT), surge and electromagnetic emissions. These electromagnetic disturbances are regulated by international standards such as IEC 61000-4-x and CISPR 22. Although system-level performance and reliability depends, to a large extent, on the application board design and layout, the ISO14xx devices incorporate dedicated circuitry to protect the transceiver from  $\pm 16$  kV ESD per IEC61000-4-2 and  $\pm 4$  kV EFT per IEC 61000-4-4. System designers can achieve the  $\pm 4$ -kV EFT Criterion A with careful system design (data communication between nodes in the presence of transient noise with minimum to no data loss).

### 9.3.2 Failsafe Receiver

The differential receiver of the ISO14xx devices has failsafe protection from invalid bus states caused by:

- Open bus conditions such as a broken cable or a disconnected connector
- Shorted bus conditions such as insulation breakdown of a cable that shorts the twisted-pair
- Idle bus conditions that occur when no driver on the bus is actively driving

The differential input of the RS-485 receiver is 0 in any of these conditions for a terminated transmission line. The receiver outputs a failsafe logic-high state so that the output of the receiver is not indeterminate.

The receiver thresholds are offset in the receiver failsafe protection so that the indeterminate range of the does not include a 0 V differential. The receiver output must generate a logic high when the differential input ( $V_{ID}$ ) is greater than 200 mV to comply with the RS-485 standard. The receiver output must also generate a output a logic low when  $V_{ID}$  is less than  $-200$  mV to comply with the RS-485 standard. The receiver parameters that determine the failsafe performance are  $V_{TH+}$ ,  $V_{TH-}$ , and  $V_{HYS}$ . Differential signals less than  $-200$  mV always cause a low receiver output as shown in the *Electrical Characteristics* table. Differential signals greater than 200 mV always cause a high receiver output. A differential input signal that is near zero is still greater than the  $V_{TH+}$  threshold which makes the receiver output logic high. The receiver output goes to a low state only when the differential input decreases by  $V_{HYS}$  to less than  $V_{TH+}$ .

The internal failsafe biasing feature removes the need for the two external resistors that are typically required with traditional isolated RS-485 transceivers as shown in [Figure 9-3](#).

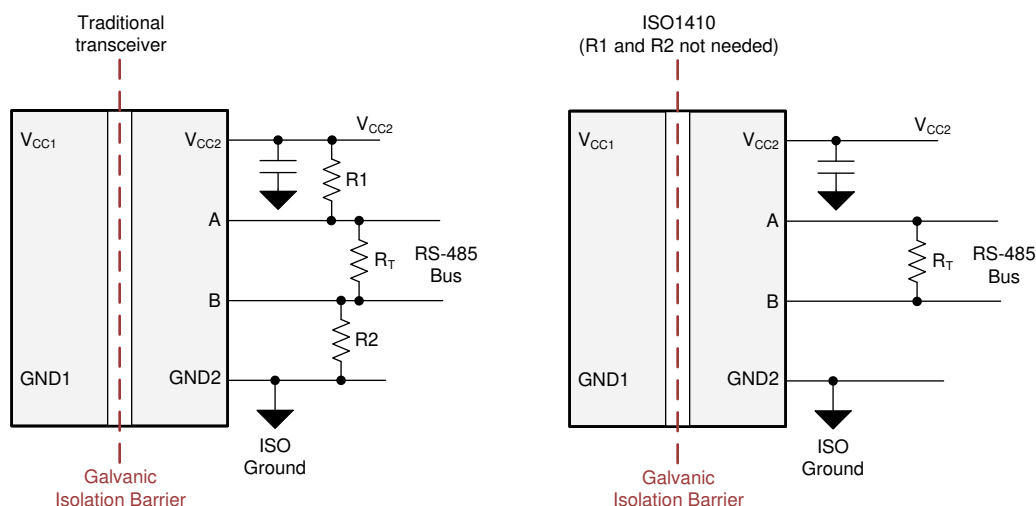


Figure 9-3. Failsafe Transceiver

### 9.3.3 Thermal Shutdown

The ISO14xx devices have a thermal shutdown circuit to protect against damage when a fault condition occurs. A driver output short circuit or bus contention condition can cause the driver current to increase significantly which increases the power dissipation inside the device. An increase in the die temperature is monitored and

the device is disabled when the die temperature becomes 170°C (typical) which lets the device decrease the temperature. The device is enabled when the junction temperature becomes 165°C (typical).

Bus short circuit for an extended duration and/or beyond voltage levels specified in recommended operating condition should be avoided. Repeated or prolonged exposure to bus shorts can result in high junction temperatures and affect device reliability.

### 9.3.4 Glitch-Free Power Up and Power Down

Communication on the bus that already exist between a master node and slave node in an RS485 network must not be disturbed when a new node is swapped in or out of the network. No glitches on the bus occur when the device is:

- Hot plugged into the network in an unpowered state
- Hot plugged into the network in a powered state and disabled state
- Powered up or powered down in a disabled state when already connected to the bus

The ISO14xx devices do not cause any false data toggling on the bus when powered up or powered down in a disabled state with supply ramp rates from 100 µs to 10 ms.

## 9.4 Device Functional Modes

Table 9-1 shows the driver functional modes.

**Table 9-1. Driver Functional Table**

V <sub>CC1</sub> <sup>(1)</sup>	V <sub>CC2</sub> <sup>(1)</sup>	INPUT D	DRIVER ENABLE DE	OUTPUTS <sup>(3)</sup>	
				Y, A	Z, B
PU	PU	H	H	H	L
		L	H	L	H
		X	L	Hi-Z	Hi-Z
		X	Open	Hi-Z	Hi-Z
		Open	H	H	L
PD <sup>(2)</sup>	PU	X	X	Hi-Z	Hi-Z
X	PD	X	X	Hi-Z	Hi-Z

- (1) PU = Powered Up; PD = Powered Down; H = High Level; L = Low level; X = Irrelevant, Hi-Z = High impedance state  
 (2) A strongly driven input signal can weakly power the floating V<sub>CC1</sub> through an internal protection diode and cause an undetermined output.  
 (3) The driver outputs are Y and Z for a full-duplex device. The driver outputs are A and B for a half-duplex device.

The description that follows is specific to half-duplex device but the same logic applies to full-duplex device with the outputs being Y and Z.

When the driver enable pin, DE, is logic high, the differential outputs, A and B, follow the logic states at data input, D. A logic high at the D input causes the A output to go high and the B output to go low. Therefore the differential output voltage defined by Equation 1 is positive.

$$V_{OD} = V_A - V_B \tag{1}$$

A logic low at the D input causes the B output to go high and the A output to go low. Therefore the differential output voltage defined by Equation 1 is negative. A logic low at the DE input causes both outputs to go to the high-impedance (Hi-Z) state. The logic state at the D pin is irrelevant when the DE input is logic low. The DE pin has an internal pulldown resistor to ground. The driver is disabled (bus outputs are in the Hi-Z) by default when the DE pin is left open. The D pin has an internal pullup resistor. The A output goes high and the B output goes low when the D pin is left open while the driver enabled.

Table 9-2 shows the receiver functional modes.

**Table 9-2. Receiver Functional Table**

$V_{CC1}^{(1)}$	$V_{CC2}^{(1)}$	DIFFERENTIAL INPUT	RECEIVER ENABLE $\overline{RE}$	OUTPUT R
		$V_{ID} = V_A - V_B$		
PU	PU	$-0.02\text{ V} \leq V_{ID}$	L	H
		$-0.2\text{ V} < V_{ID} < 0.02\text{ V}$	L	Indeterminate
		$V_{ID} \leq -0.2\text{ V}$	L	L
		X	H	Hi-Z
		X	Open	Hi-Z
		Open, Short, Idle	L	H
PD <sup>(2)</sup>	PU	X	X	Hi-Z
PU	PD	X	L	H
PD <sup>(2)</sup>	PD	X	X	Hi-Z

(1) PU = Powered Up; PD = Powered Down; H = Logic High; L = Logic Low; X = Irrelevant, Hi-Z = High Impedance (OFF) state

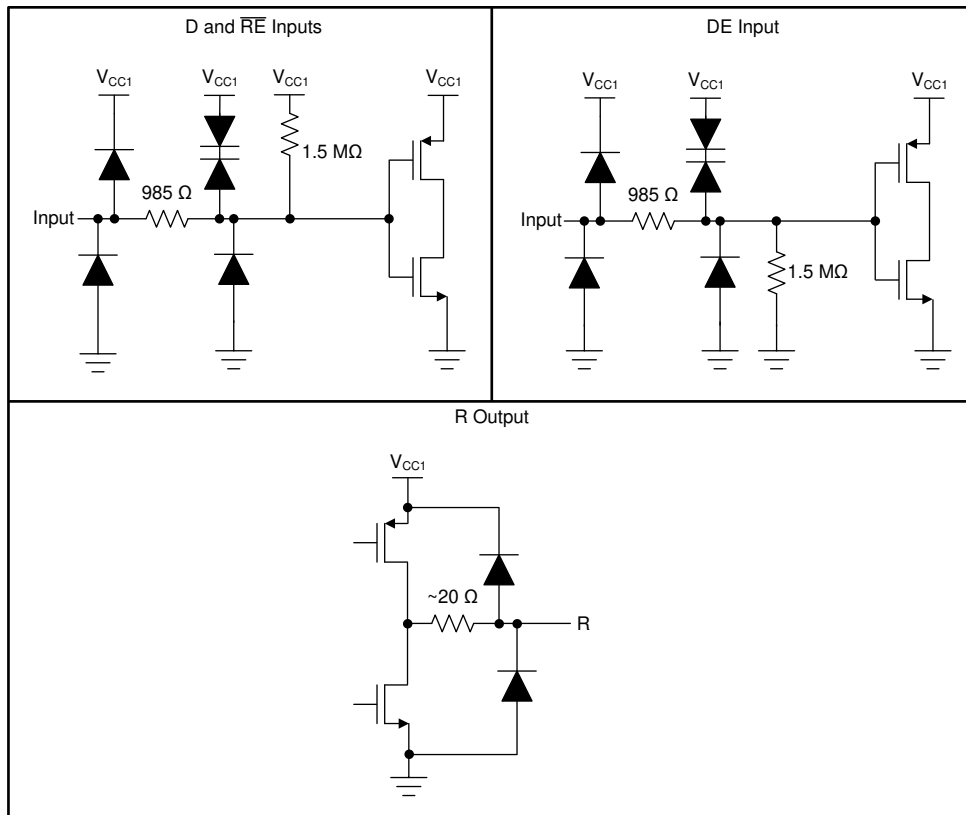
(2) A strongly driven input signal can weakly power the floating  $V_{CC1}$  through an internal protection diode and cause an undetermined output.

The receiver is enabled when the receiver enable pin,  $\overline{RE}$ , is logic low. The receiver output, R, goes high when the differential input voltage defined by Equation 2 is greater than the positive input threshold,  $V_{TH+}$ .

$$V_{ID} = V_A - V_B \quad (2)$$

The receiver output, R, goes low when the differential input voltage defined by Equation 2 is less than the negative input threshold,  $V_{TH-}$ . If the  $V_{ID}$  voltage is between the  $V_{TH+}$  and  $V_{TH-}$  thresholds, the output is indeterminate. The receiver output is in the Hi-Z state and the magnitude and polarity of  $V_{ID}$  are irrelevant when the  $\overline{RE}$  pin is logic high or left open. The internal biasing of the receiver inputs causes the output to go to a failsafe-high when the transceiver is disconnected from the bus (open-circuit), the bus lines are shorted to one another (short-circuit), or the bus is not actively driven (idle bus).

### 9.4.1 Device I/O Schematics



**Figure 9-4. Device I/O Schematics**

## 10 Application and Implementation

### Note

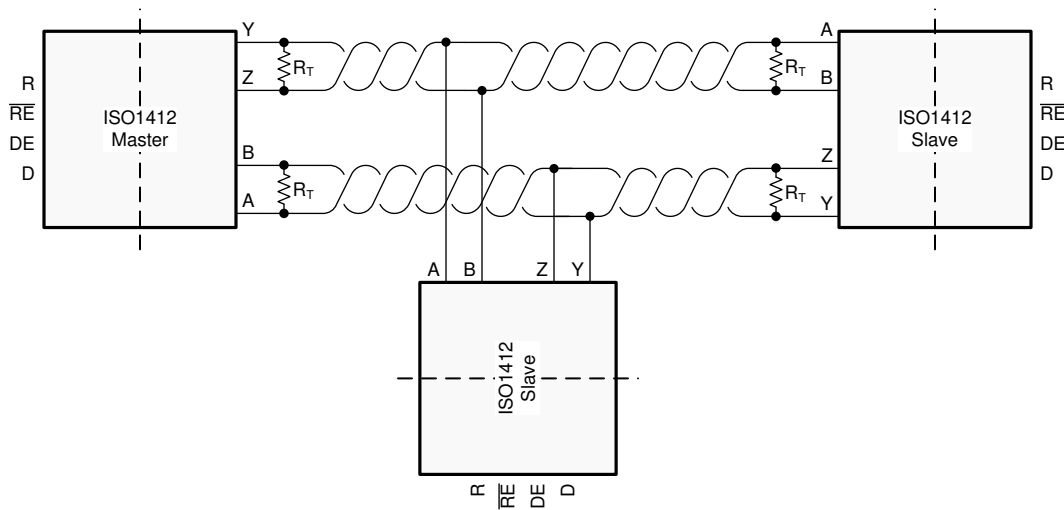
Information in the following applications sections is not part of the TI component specification, and TI does not warrant its accuracy or completeness. TI's customers are responsible for determining suitability of components for their purposes, as well as validating and testing their design implementation to confirm system functionality.

### 10.1 Application Information

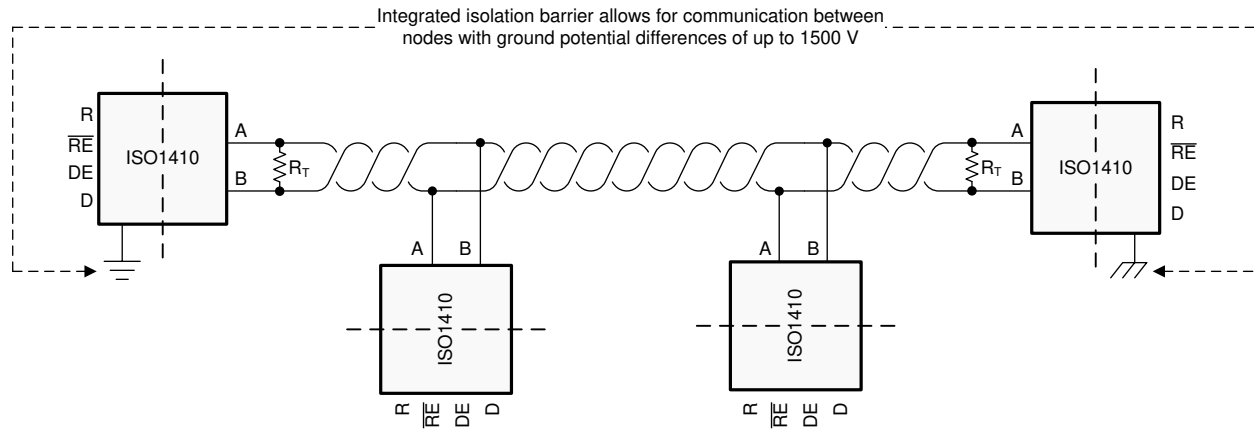
The ISO14xx devices are designed for bidirectional data transfer on multipoint RS-485 networks. The design of each RS-485 node in the network requires an ISO14xx device and an isolated power supply as shown in [Figure 10-3](#).

An RS-485 bus has multiple transceivers that connect in parallel to a bus cable. Both cable ends are terminated with a termination resistor,  $R_T$ , to remove line reflections. The value of  $R_T$  matches the characteristic impedance,  $Z_0$ , of the cable. This method, known as parallel termination, lets higher data rates be used over a longer cable length.

Full-duplex implementation, as shown in [Figure 10-1](#), requires two signal pairs (four wires). Full-duplex implementation lets each node to transmit data on one pair while simultaneously receiving data on the other pair. In half-duplex implementation, as shown in [Figure 10-2](#), the driver and receiver enable pins let any node at any given moment be configured in either transmit or receive mode which decreases cable requirements.



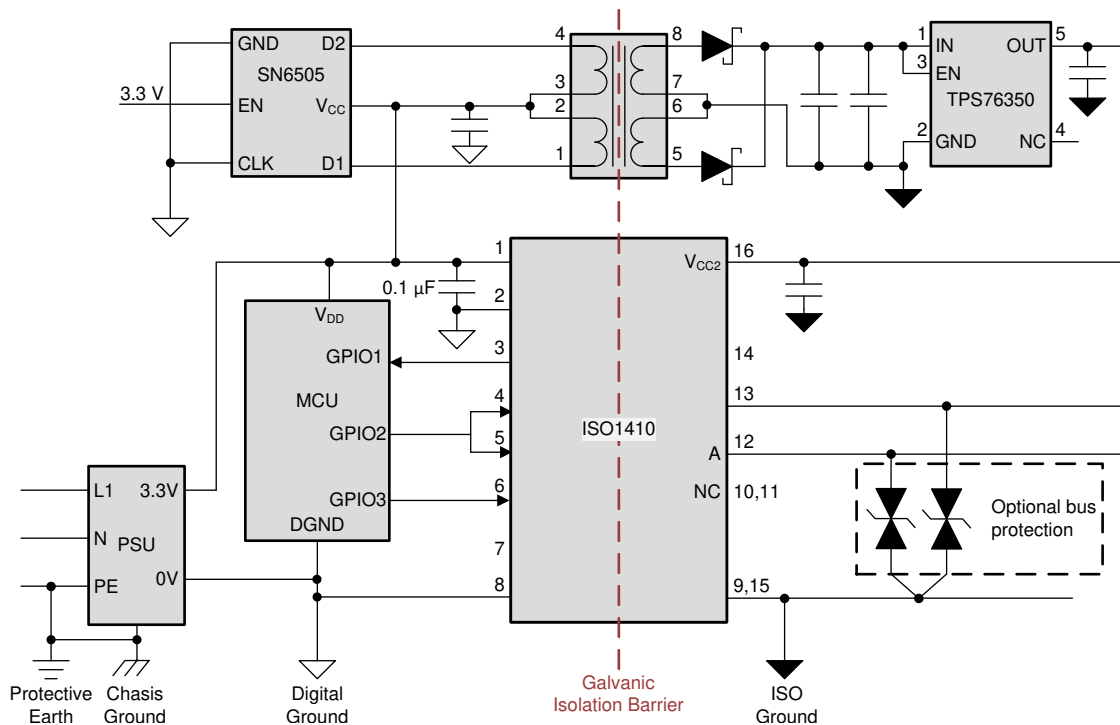
**Figure 10-1. Typical RS-485 Network With Full-Duplex Isolated Transceivers**



**Figure 10-2. Typical RS-485 Network With Half-Duplex Isolated Transceivers**

## 10.2 Typical Application

Figure 10-3 shows the application circuit of the ISO1410 device.



**Figure 10-3. Application Circuit of ISO1410**

### 10.2.1 Design Requirements

Unlike an optocoupler-based solution, which requires several external components to improve performance, provide bias, or limit current, the ISO14xx devices only require external bypass capacitors to operate.

### 10.2.2 Detailed Design Procedure

The RS-485 bus is a robust electrical interface suitable for long-distance communications. The RS-485 interface can be used in a wide range of applications with varying requirements of distance of communication, data rate, and number of nodes.

### 10.2.2.1 Data Rate and Bus Length

The RS-485 standard has typical curves similar to those shown in Figure 10-4. These curves show the inverse relationship between signaling rate and cable length. If the data rate of the payload between two nodes is lower, the cable length between the nodes can be longer.

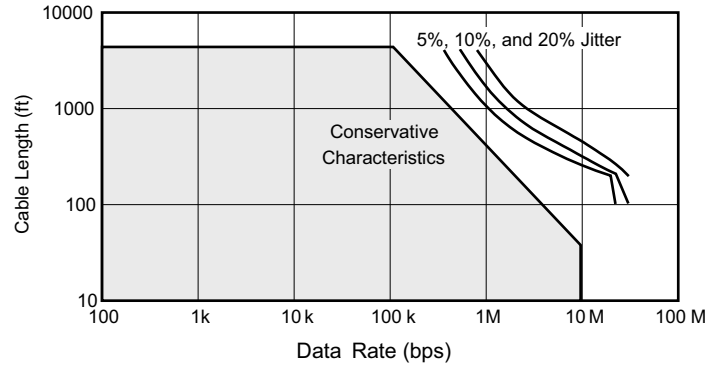


Figure 10-4. Cable Length vs Data Rate Characteristics

Use Figure 10-4 as a guideline for cable selection, data rate, cable length and subsequent jitter budgeting.

### 10.2.2.2 Stub Length

In an RS-485 network, the distance between the transceiver inputs and the cable trunk is known as the *stub*. The stub should be as short as possible when a node is connected to the bus. Stubs are a non-terminated piece of bus line that can introduce reflections of varying phase as the length of the stub increases. The electrical length, or round-trip delay, of a stub should be less than one-tenth of the rise time of the driver as a general guideline. Therefore, the maximum physical stub length ( $L_{(STUB)}$ ) is calculated as shown in Equation 3.

$$L_{(STUB)} \leq 0.1 \times t_r \times v \times c \quad (3)$$

where

- $t_r$  is the 10/90 rise time of the driver.
- $c$  is the speed of light ( $3 \times 10^8$  m/s).
- $v$  is the signal velocity of the cable or trace as a factor of  $c$ .

### 10.2.2.3 Bus Loading

The current supplied by the driver must supply into a load because the output of the driver depends on this current. Add transceivers to the bus to increase the total bus loading. The RS-485 standard specifies a hypothetical term of a unit load (UL) to estimate the maximum number of possible bus loads. The UL represents a load impedance of approximately 12 k $\Omega$ . Standard-compliant drivers must be able to drive 32 of these ULs.

The ISO14xx devices have 1/8 UL impedance transceiver and can connect up to 256 nodes to the bus.

### 10.2.3 Application Curves

Below eye diagram of ISO145x device indicates low jitter and wide open eye at maximum data rate of 50 Mbps.

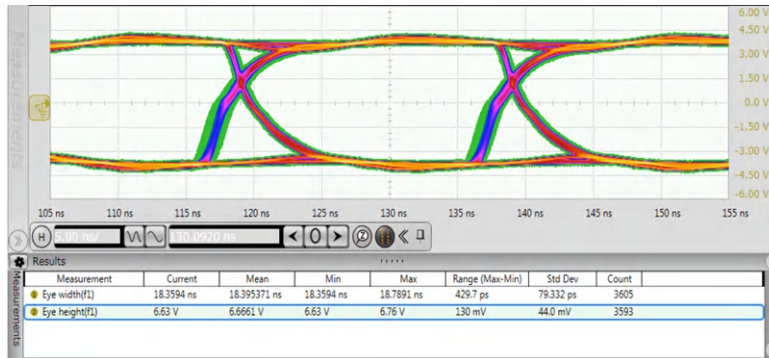


Figure 10-5. Eye Diagram at 50 Mbps Clock,  $V_{CC2} = 5\text{ V}$ ,  $25^{\circ}\text{C}$

### 10.2.3.1 Insulation Lifetime

Insulation lifetime projection data is collected by using industry-standard Time Dependent Dielectric Breakdown (TDDB) test method. In this test, all pins on each side of the barrier are tied together creating a two-terminal device and high voltage applied between the two sides; See Figure 10-6 for TDDB test setup. The insulation breakdown data is collected at various high voltages switching at 60 Hz over temperature. For reinforced insulation, VDE standard requires the use of TDDB projection line with failure rate of less than 1 part per million (ppm). Even though the expected minimum insulation lifetime is 20 years at the specified working isolation voltage, VDE reinforced certification requires additional safety margin of 20% for working voltage and 87.5% for lifetime which translates into minimum required insulation lifetime of 37.5 years at a working voltage that's 20% higher than the specified value.

Figure 10-7 shows the intrinsic capability of the isolation barrier to withstand high voltage stress over its lifetime. Based on the TDDB data, the intrinsic capability of the insulation is  $1060\text{ V}_{\text{RMS}}$  with a lifetime of 220 years. Other factors, such as package size, pollution degree, material group, etc. can further limit the working voltage of the component. The working voltage of DW-16 is specified up to  $1060\text{ V}_{\text{RMS}}$ . At the lower working voltages, the corresponding insulation lifetime is much longer than 220 years.

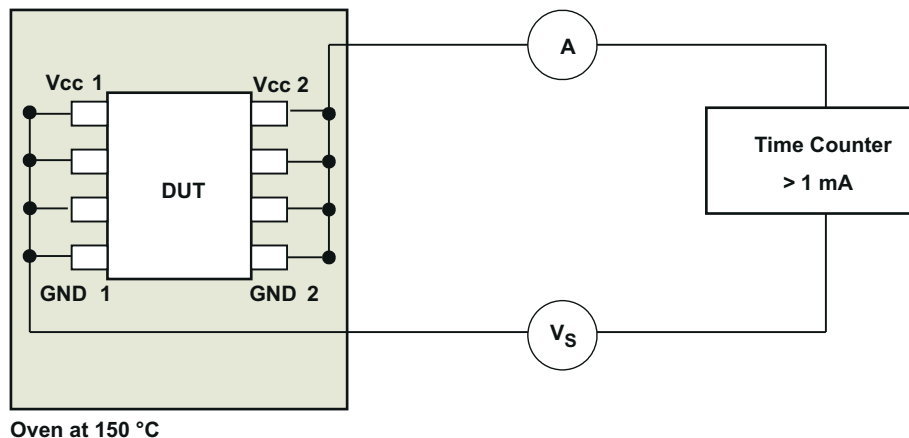
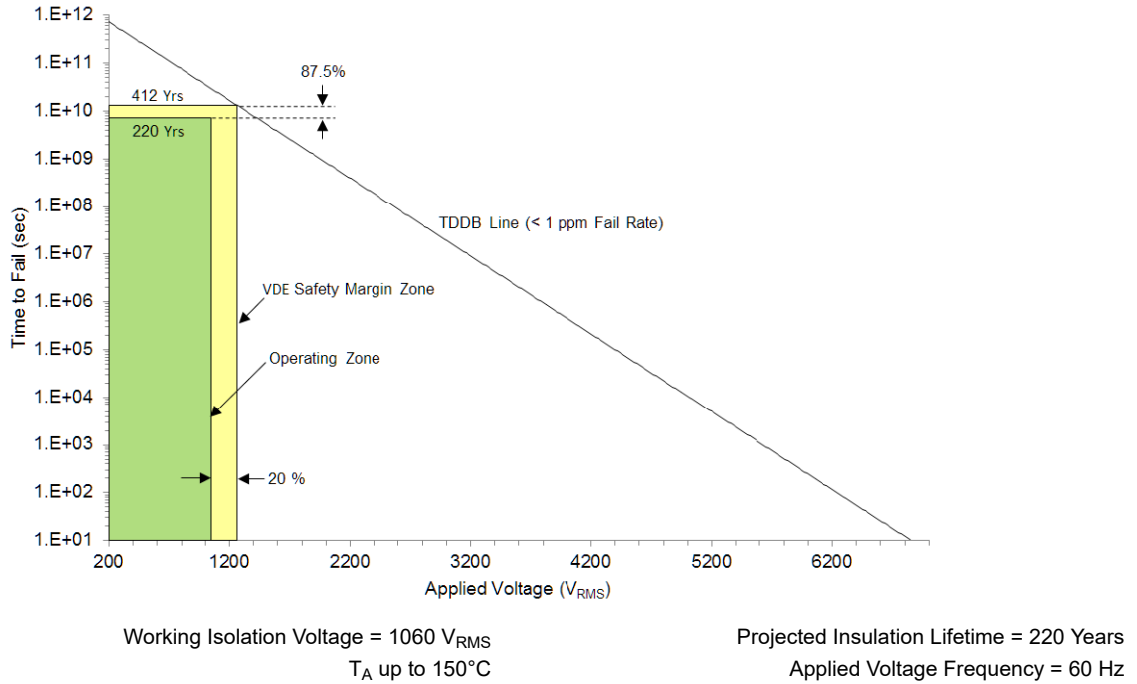


Figure 10-6. Test Setup for Insulation Lifetime Measurement





**Figure 10-7. Insulation Lifetime Projection Data**

## 11 Power Supply Recommendations

To make sure device operation is reliable at all data rates and supply voltages, a 0.1- $\mu$ F bypass capacitor is recommended at the logic and transceiver supply pins ( $V_{CC1}$  and  $V_{CC2}$ ). The capacitors should be placed as near to the supply pins as possible. Additionally, a 10  $\mu$ F bulk capacitor on  $V_{CC2}$  improves transceiver performance during bus transitions in transmit mode. If only one primary-side power supply is available in an application, isolated power can be generated for the secondary-side with the help of a transformer driver such as TI's [SN6505B](#) device. For such applications, detailed power supply design and transformer selection recommendations are available in the [SN6505 Low-Noise 1-A Transformer Drivers for Isolated Power Supplies data sheet](#).

## 12 Layout

### 12.1 Layout Guidelines

A minimum of four layers is required to accomplish a low EMI PCB design (see [Figure 12-2](#)). Layer stacking must be in the following order (top-to-bottom): high-speed signal layer, ground plane, power plane and low-frequency signal layer.

- Routing the high-speed traces on the top layer avoids the use of vias (and the introduction of the inductances) and allows for clean interconnects between the isolator and the transmitter and receiver circuits of the data link.
- Placing a solid ground plane next to the high-speed signal layer establishes controlled impedance for transmission line interconnects and provides an excellent low-inductance path for the return current flow.
- Placing the power plane next to the ground plane creates additional high-frequency bypass capacitance of approximately 100 pF/in<sup>2</sup>.
- Routing the slower speed control signals on the bottom layer allows for greater flexibility as these signal links usually have margin to tolerate discontinuities such as vias.

[Section 12.2](#) shows the recommended placement and routing of the device bypass capacitors and optional TVS diodes. Put the  $V_{CC2}$  bypass capacitors on the top layer and as near to the device pins as possible. Do not use vias to complete the connection to the  $V_{CC2}$  and GND2 pins. If an additional supply voltage plane or signal layer is needed, add a second power or ground plane system to the stack to keep the it symmetrical. This makes the stack mechanically stable and prevents it from warping. Also the power and ground plane of each power system can be placed closer together, thus increasing the high-frequency bypass capacitance significantly.

Refer to the [Digital Isolator Design Guide](#) for detailed layout recommendations.

#### 12.1.1 PCB Material

For digital circuit boards operating at less than 150 Mbps, (or rise and fall times greater than 1 ns), and trace lengths of up to 10 inches, use standard FR-4 UL94V-0 printed circuit board. This PCB is preferred over cheaper alternatives because of lower dielectric losses at high frequencies, less moisture absorption, greater strength and stiffness, and the self-extinguishing flammability-characteristics.

### 12.2 Layout Example

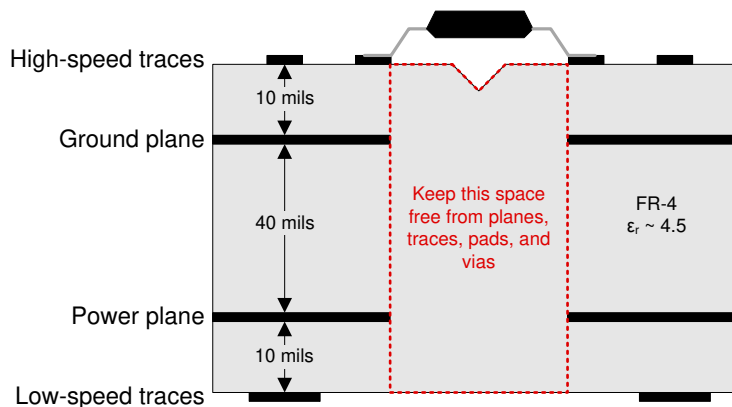
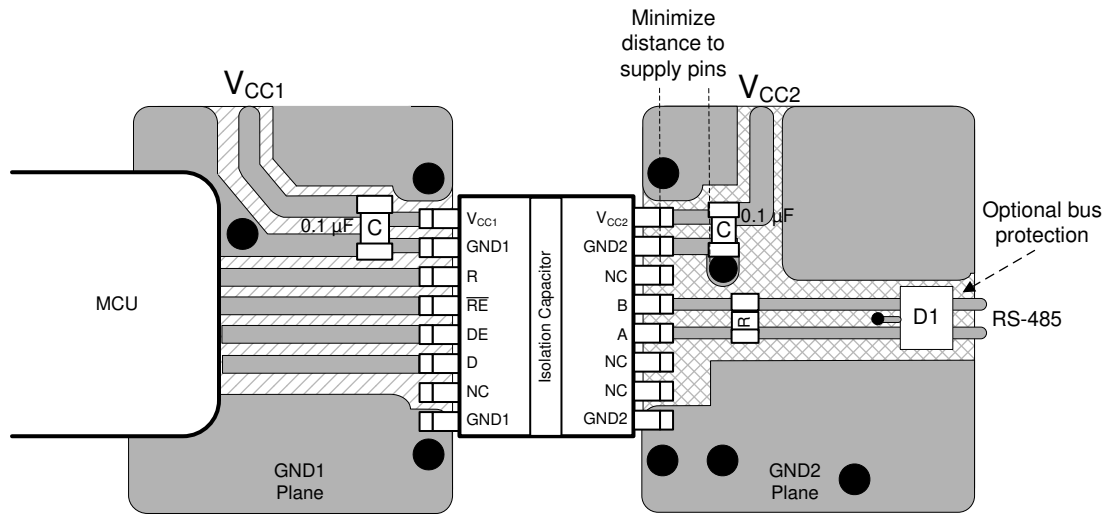


Figure 12-1. Recommended Layer Stack



**Figure 12-2. Layout Example**

## 13 Device and Documentation Support

### 13.1 Documentation Support

#### 13.1.1 Related Documentation

For related documentation see the following:

- Texas Instruments, [Digital Isolator Design Guide](#), application note
- Texas Instruments, [Isolation Glossary](#), application note
- Texas Instruments, [Isolated RS-485 Half-Duplex Evaluation Module](#) user's guide
- Texas Instruments, [How to isolate signal and power for an RS-485 system](#), application brief
- Texas Instruments, [Robust Isolated RS-485 for industrial long-haul communications](#), application brief

#### 13.1.1.1 Related Links

The table below lists quick access links. Categories include technical documents, support and community resources, tools and software, and quick access to order now.

**Table 13-1. Related Links**

PARTS	PRODUCT FOLDER	ORDER NOW	TECHNICAL DOCUMENTS	TOOLS & SOFTWARE	SUPPORT & COMMUNITY
ISO1410	<a href="#">Click here</a>	<a href="#">Click here</a>	<a href="#">Click here</a>	<a href="#">Click here</a>	<a href="#">Click here</a>
ISO1412	<a href="#">Click here</a>	<a href="#">Click here</a>	<a href="#">Click here</a>	<a href="#">Click here</a>	<a href="#">Click here</a>
ISO1430	<a href="#">Click here</a>	<a href="#">Click here</a>	<a href="#">Click here</a>	<a href="#">Click here</a>	<a href="#">Click here</a>
ISO1432	<a href="#">Click here</a>	<a href="#">Click here</a>	<a href="#">Click here</a>	<a href="#">Click here</a>	<a href="#">Click here</a>
ISO1450	<a href="#">Click here</a>	<a href="#">Click here</a>	<a href="#">Click here</a>	<a href="#">Click here</a>	<a href="#">Click here</a>
ISO1452	<a href="#">Click here</a>	<a href="#">Click here</a>	<a href="#">Click here</a>	<a href="#">Click here</a>	<a href="#">Click here</a>
ISO1410B	<a href="#">Click here</a>	<a href="#">Click here</a>	<a href="#">Click here</a>	<a href="#">Click here</a>	<a href="#">Click here</a>
ISO1412B	<a href="#">Click here</a>	<a href="#">Click here</a>	<a href="#">Click here</a>	<a href="#">Click here</a>	<a href="#">Click here</a>
ISO1430B	<a href="#">Click here</a>	<a href="#">Click here</a>	<a href="#">Click here</a>	<a href="#">Click here</a>	<a href="#">Click here</a>
ISO1432B	<a href="#">Click here</a>	<a href="#">Click here</a>	<a href="#">Click here</a>	<a href="#">Click here</a>	<a href="#">Click here</a>
ISO1450B	<a href="#">Click here</a>	<a href="#">Click here</a>	<a href="#">Click here</a>	<a href="#">Click here</a>	<a href="#">Click here</a>
ISO1452B	<a href="#">Click here</a>	<a href="#">Click here</a>	<a href="#">Click here</a>	<a href="#">Click here</a>	<a href="#">Click here</a>

### 13.2 Receiving Notification of Documentation Updates

To receive notification of documentation updates, navigate to the device product folder on [ti.com](#). Click on *Notifications* to register and receive a weekly digest of any product information that has changed. For change details, review the revision history included in any revised document.

### 13.3 Support Resources

[TI E2E™ support forums](#) are an engineer's go-to source for fast, verified answers and design help — straight from the experts. Search existing answers or ask your own question to get the quick design help you need.

Linked content is provided "AS IS" by the respective contributors. They do not constitute TI specifications and do not necessarily reflect TI's views; see TI's [Terms of Use](#).

### 13.4 Trademarks

TI E2E™ is a trademark of Texas Instruments.  
 All trademarks are the property of their respective owners.

### 13.5 Electrostatic Discharge Caution



This integrated circuit can be damaged by ESD. Texas Instruments recommends that all integrated circuits be handled with appropriate precautions. Failure to observe proper handling and installation procedures can cause damage.

ESD damage can range from subtle performance degradation to complete device failure. Precision integrated circuits may be more susceptible to damage because very small parametric changes could cause the device not to meet its published specifications.

## 13.6 Glossary

[TI Glossary](#) This glossary lists and explains terms, acronyms, and definitions.

## 14 Revision History

NOTE: Page numbers for previous revisions may differ from page numbers in the current version.

### Changes from Revision G (May 2020) to Revision H (June 2024) Page

- Updated the number format for tables, figures, and cross-references throughout the document..... 1

### Changes from Revision F (February 2020) to Revision G (May 2020) Page

- Added minimum driver rise/fall time specification of 240 ns to [8.13 Switching characteristics: Driver \(500kbps devices\)](#) ..... 13

### Changes from Revision E (October 2019) to Revision F (February 2020) Page

- Added updated certification information in [Safety-Related Certifications](#) ..... 8

### Changes from Revision D (May 2019) to Revision E (October 2019) Page

- Added footnote to Pin functions table for NC pins ..... 3

### Changes from Revision C (April 2019) to Revision D (May 2019) Page

- Added B part numbers throughout datasheet ..... 1

### Changes from Revision B (November 2018) to Revision C (April 2019) Page

- Added ISO1430, ISO1432, ISO1450, ISO1452 in Device Information table..... 1
- Changed *Device Features* tables to *Device Comparison* table..... 2
- Changed the position of Device Features tables ..... 2
- Added footnote to Pin Functions: Full-Duplex Device..... 3
- Added footnote to Pin Functions: Half-Duplex Device..... 4
- Added Typical curves for ISO143x and ISO145x in [Section 7.16](#) ..... 15
- Added Section 11.2.3 Application Curves and Section 11.2.3.1 Insulation Lifetime..... 31

### Changes from Revision A (August 2018) to Revision B (November 2018) Page

- Changed status to production data ..... 1

### Changes from Revision \* (July 2018) to Revision A (August 2018) Page

- Changed the designator of common mode voltage in Recommended operating condition to  $V_1$  ..... 6
- Added test condition for CMTI in Electrical characteristics: Driver ..... 9
- Added test condition for CMTI in Electrical characteristics: Receiver..... 10
- Changed  $V_{TEST}$  to  $V_{CM}$  in the *Common Mode Transient Immunity (CMTI)—Full Duplex* and *Common Mode Transient Immunity (CMTI)—Half Duplex* figures in the *Parameter Measurement Information* section..... 21

- 
- Changed  $t_{PLH}$  to  $t_{PZH}$  and  $t_{PLZ}$  to  $t_{PHZ}$  in the first *Driver Enable and Disable Times* timing diagram in the *Parameter Measurement Information* section.....21
  - Added  $t_{PHZ}$  to the first *Receiver Enable and Disable Times* timing diagram in the *Parameter Measurement Information* section ..... 21
- 

## 15 Mechanical, Packaging, and Orderable Information

The following pages include mechanical packaging and orderable information. This information is the most current data available for the designated devices. This data is subject to change without notice and revision of this document. For browser-based versions of this data sheet, refer to the left-hand navigation.

**PACKAGING INFORMATION**

Orderable part number	Status (1)	Material type (2)	Package   Pins	Package qty   Carrier	RoHS (3)	Lead finish/ Ball material (4)	MSL rating/ Peak reflow (5)	Op temp (°C)	Part marking (6)
<a href="#">ISO1410BDW</a>	Active	Production	SOIC (DW)   16	40   TUBE	Yes	NIPDAU	Level-2-260C-1 YEAR	-40 to 125	ISO1410B
<a href="#">ISO1410BDWR</a>	Active	Production	SOIC (DW)   16	2000   LARGE T&R	Yes	NIPDAU	Level-2-260C-1 YEAR	-40 to 125	ISO1410B
<a href="#">ISO1410DW</a>	Active	Production	SOIC (DW)   16	40   TUBE	Yes	NIPDAU	Level-2-260C-1 YEAR	-40 to 125	ISO1410
<a href="#">ISO1410DWR</a>	Active	Production	SOIC (DW)   16	2000   LARGE T&R	Yes	NIPDAU	Level-2-260C-1 YEAR	-40 to 125	ISO1410
ISO1410DWRG4	Active	Production	SOIC (DW)   16	2000   LARGE T&R	Yes	NIPDAU	Level-2-260C-1 YEAR	-40 to 125	ISO1410
<a href="#">ISO1412BDW</a>	Active	Production	SOIC (DW)   16	40   TUBE	Yes	NIPDAU	Level-2-260C-1 YEAR	-40 to 125	ISO1412B
<a href="#">ISO1412BDWR</a>	Active	Production	SOIC (DW)   16	2000   LARGE T&R	Yes	NIPDAU	Level-2-260C-1 YEAR	-40 to 125	ISO1412B
<a href="#">ISO1412DW</a>	Active	Production	SOIC (DW)   16	40   TUBE	Yes	NIPDAU	Level-2-260C-1 YEAR	-40 to 125	ISO1412
<a href="#">ISO1412DWR</a>	Active	Production	SOIC (DW)   16	2000   LARGE T&R	Yes	NIPDAU	Level-2-260C-1 YEAR	-40 to 125	ISO1412
<a href="#">ISO1430BDW</a>	Active	Production	SOIC (DW)   16	40   TUBE	Yes	NIPDAU	Level-2-260C-1 YEAR	-40 to 125	ISO1430B
<a href="#">ISO1430BDWR</a>	Active	Production	SOIC (DW)   16	2000   LARGE T&R	Yes	NIPDAU	Level-2-260C-1 YEAR	-40 to 125	ISO1430B
<a href="#">ISO1430DW</a>	Active	Production	SOIC (DW)   16	40   TUBE	Yes	NIPDAU	Level-2-260C-1 YEAR	-40 to 125	ISO1430
<a href="#">ISO1430DWR</a>	Active	Production	SOIC (DW)   16	2000   LARGE T&R	Yes	NIPDAU	Level-2-260C-1 YEAR	-40 to 125	ISO1430
ISO1430DWRG4	Active	Production	SOIC (DW)   16	2000   LARGE T&R	Yes	NIPDAU	Level-2-260C-1 YEAR	-40 to 125	ISO1430
<a href="#">ISO1432BDW</a>	Active	Production	SOIC (DW)   16	40   TUBE	Yes	NIPDAU	Level-2-260C-1 YEAR	-40 to 125	ISO1432B
<a href="#">ISO1432BDWR</a>	Active	Production	SOIC (DW)   16	2000   LARGE T&R	Yes	NIPDAU	Level-2-260C-1 YEAR	-40 to 125	ISO1432B
<a href="#">ISO1432DW</a>	Active	Production	SOIC (DW)   16	40   TUBE	Yes	NIPDAU	Level-2-260C-1 YEAR	-40 to 125	ISO1432
<a href="#">ISO1432DWR</a>	Active	Production	SOIC (DW)   16	2000   LARGE T&R	Yes	NIPDAU	Level-2-260C-1 YEAR	-40 to 125	ISO1432
<a href="#">ISO1450BDW</a>	Active	Production	SOIC (DW)   16	40   TUBE	Yes	NIPDAU	Level-2-260C-1 YEAR	-40 to 125	ISO1450B
<a href="#">ISO1450BDWR</a>	Active	Production	SOIC (DW)   16	2000   LARGE T&R	Yes	NIPDAU	Level-2-260C-1 YEAR	-40 to 125	ISO1450B
ISO1450BDWRG4	Active	Production	SOIC (DW)   16	2000   LARGE T&R	Yes	NIPDAU	Level-2-260C-1 YEAR	-40 to 125	ISO1450B
<a href="#">ISO1450DW</a>	Active	Production	SOIC (DW)   16	40   TUBE	Yes	NIPDAU	Level-2-260C-1 YEAR	-40 to 125	ISO1450
<a href="#">ISO1450DWR</a>	Active	Production	SOIC (DW)   16	2000   LARGE T&R	Yes	NIPDAU	Level-2-260C-1 YEAR	-40 to 125	ISO1450
<a href="#">ISO1452BDW</a>	Active	Production	SOIC (DW)   16	40   TUBE	Yes	NIPDAU	Level-2-260C-1 YEAR	-40 to 125	ISO1452B
<a href="#">ISO1452BDWR</a>	Active	Production	SOIC (DW)   16	2000   LARGE T&R	Yes	NIPDAU	Level-2-260C-1 YEAR	-40 to 125	ISO1452B
<a href="#">ISO1452DW</a>	Active	Production	SOIC (DW)   16	40   TUBE	Yes	NIPDAU	Level-2-260C-1 YEAR	-40 to 125	ISO1452
<a href="#">ISO1452DWR</a>	Active	Production	SOIC (DW)   16	2000   LARGE T&R	Yes	NIPDAU	Level-2-260C-1 YEAR	-40 to 125	ISO1452

(1) **Status:** For more details on status, see our [product life cycle](#).

- (2) **Material type:** When designated, preproduction parts are prototypes/experimental devices, and are not yet approved or released for full production. Testing and final process, including without limitation quality assurance, reliability performance testing, and/or process qualification, may not yet be complete, and this item is subject to further changes or possible discontinuation. If available for ordering, purchases will be subject to an additional waiver at checkout, and are intended for early internal evaluation purposes only. These items are sold without warranties of any kind.
- (3) **RoHS values:** Yes, No, RoHS Exempt. See the [TI RoHS Statement](#) for additional information and value definition.
- (4) **Lead finish/Ball material:** Parts may have multiple material finish options. Finish options are separated by a vertical ruled line. Lead finish/Ball material values may wrap to two lines if the finish value exceeds the maximum column width.
- (5) **MSL rating/Peak reflow:** The moisture sensitivity level ratings and peak solder (reflow) temperatures. In the event that a part has multiple moisture sensitivity ratings, only the lowest level per JEDEC standards is shown. Refer to the shipping label for the actual reflow temperature that will be used to mount the part to the printed circuit board.
- (6) **Part marking:** There may be an additional marking, which relates to the logo, the lot trace code information, or the environmental category of the part.

Multiple part markings will be inside parentheses. Only one part marking contained in parentheses and separated by a "~" will appear on a part. If a line is indented then it is a continuation of the previous line and the two combined represent the entire part marking for that device.

**Important Information and Disclaimer:** The information provided on this page represents TI's knowledge and belief as of the date that it is provided. TI bases its knowledge and belief on information provided by third parties, and makes no representation or warranty as to the accuracy of such information. Efforts are underway to better integrate information from third parties. TI has taken and continues to take reasonable steps to provide representative and accurate information but may not have conducted destructive testing or chemical analysis on incoming materials and chemicals. TI and TI suppliers consider certain information to be proprietary, and thus CAS numbers and other limited information may not be available for release.

In no event shall TI's liability arising out of such information exceed the total purchase price of the TI part(s) at issue in this document sold by TI to Customer on an annual basis.



**TAPE AND REEL INFORMATION**

**QUADRANT ASSIGNMENTS FOR PIN 1 ORIENTATION IN TAPE**

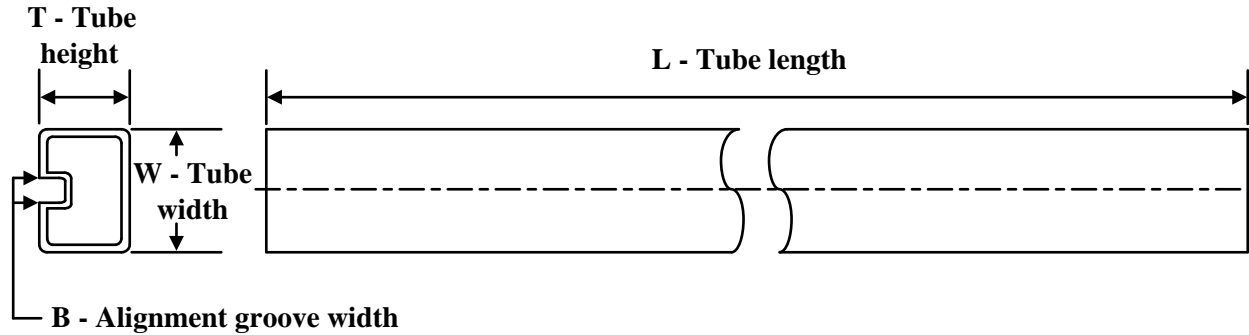

\*All dimensions are nominal

Device	Package Type	Package Drawing	Pins	SPQ	Reel Diameter (mm)	Reel Width W1 (mm)	A0 (mm)	B0 (mm)	K0 (mm)	P1 (mm)	W (mm)	Pin1 Quadrant
ISO1430BDWR	SOIC	DW	16	2000	330.0	16.4	10.75	10.7	2.7	12.0	16.0	Q1
ISO1430DWR	SOIC	DW	16	2000	330.0	16.4	10.75	10.7	2.7	12.0	16.0	Q1
ISO1430DWRG4	SOIC	DW	16	2000	330.0	16.4	10.75	10.7	2.7	12.0	16.0	Q1
ISO1432BDWR	SOIC	DW	16	2000	330.0	16.4	10.75	10.7	2.7	12.0	16.0	Q1
ISO1432DWR	SOIC	DW	16	2000	330.0	16.4	10.75	10.7	2.7	12.0	16.0	Q1
ISO1450BDWR	SOIC	DW	16	2000	330.0	16.4	10.75	10.7	2.7	12.0	16.0	Q1
ISO1450BDWRG4	SOIC	DW	16	2000	330.0	16.4	10.75	10.7	2.7	12.0	16.0	Q1
ISO1450DWR	SOIC	DW	16	2000	330.0	16.4	10.75	10.7	2.7	12.0	16.0	Q1
ISO1452BDWR	SOIC	DW	16	2000	330.0	16.4	10.75	10.7	2.7	12.0	16.0	Q1
ISO1452DWR	SOIC	DW	16	2000	330.0	16.4	10.75	10.7	2.7	12.0	16.0	Q1

**TAPE AND REEL BOX DIMENSIONS**


\*All dimensions are nominal

Device	Package Type	Package Drawing	Pins	SPQ	Length (mm)	Width (mm)	Height (mm)
ISO1430BDWR	SOIC	DW	16	2000	353.0	353.0	32.0
ISO1430DWR	SOIC	DW	16	2000	353.0	353.0	32.0
ISO1430DWRG4	SOIC	DW	16	2000	353.0	353.0	32.0
ISO1432BDWR	SOIC	DW	16	2000	353.0	353.0	32.0
ISO1432DWR	SOIC	DW	16	2000	353.0	353.0	32.0
ISO1450BDWR	SOIC	DW	16	2000	353.0	353.0	32.0
ISO1450BDWRG4	SOIC	DW	16	2000	353.0	353.0	32.0
ISO1450DWR	SOIC	DW	16	2000	353.0	353.0	32.0
ISO1452BDWR	SOIC	DW	16	2000	353.0	353.0	32.0
ISO1452DWR	SOIC	DW	16	2000	353.0	353.0	32.0

**TUBE**


\*All dimensions are nominal

Device	Package Name	Package Type	Pins	SPQ	L (mm)	W (mm)	T (μm)	B (mm)
ISO1410BDW	DW	SOIC	16	40	507	12.83	5080	6.6
ISO1410BDW	DW	SOIC	16	40	506.98	12.7	4826	6.6
ISO1410DW	DW	SOIC	16	40	506.98	12.7	4826	6.6
ISO1410DW	DW	SOIC	16	40	507	12.83	5080	6.6
ISO1412BDW	DW	SOIC	16	40	507	12.83	5080	6.6
ISO1412BDW	DW	SOIC	16	40	506.98	12.7	4826	6.6
ISO1412DW	DW	SOIC	16	40	507	12.83	5080	6.6
ISO1412DW	DW	SOIC	16	40	506.98	12.7	4826	6.6
ISO1430BDW	DW	SOIC	16	40	506.98	12.7	4826	6.6
ISO1430BDW	DW	SOIC	16	40	507	12.83	5080	6.6
ISO1430DW	DW	SOIC	16	40	506.98	12.7	4826	6.6
ISO1430DW	DW	SOIC	16	40	507	12.83	5080	6.6
ISO1432BDW	DW	SOIC	16	40	506.98	12.7	4826	6.6
ISO1432BDW	DW	SOIC	16	40	507	12.83	5080	6.6
ISO1432DW	DW	SOIC	16	40	507	12.83	5080	6.6
ISO1432DW	DW	SOIC	16	40	506.98	12.7	4826	6.6
ISO1450BDW	DW	SOIC	16	40	507	12.83	5080	6.6
ISO1450BDW	DW	SOIC	16	40	506.98	12.7	4826	6.6
ISO1450DW	DW	SOIC	16	40	507	12.83	5080	6.6
ISO1450DW	DW	SOIC	16	40	506.98	12.7	4826	6.6
ISO1452BDW	DW	SOIC	16	40	506.98	12.7	4826	6.6
ISO1452BDW	DW	SOIC	16	40	507	12.83	5080	6.6
ISO1452DW	DW	SOIC	16	40	506.98	12.7	4826	6.6
ISO1452DW	DW	SOIC	16	40	507	12.83	5080	6.6

## GENERIC PACKAGE VIEW

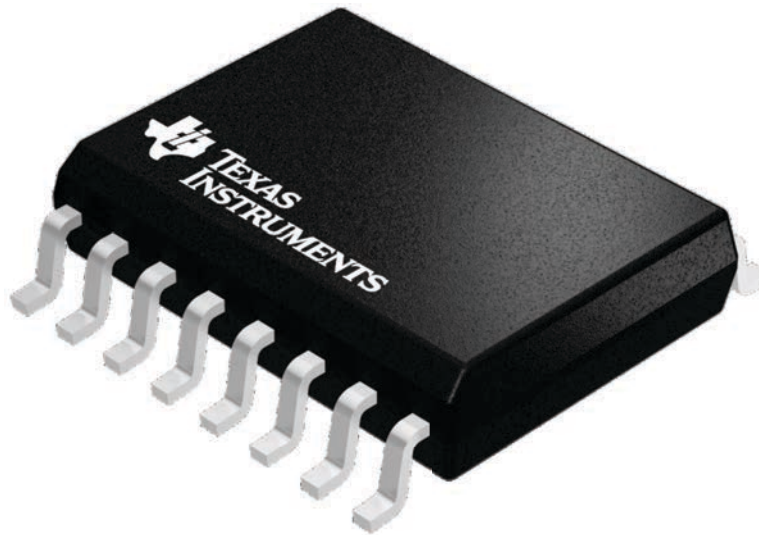
**DW 16**

**SOIC - 2.65 mm max height**

7.5 x 10.3, 1.27 mm pitch

SMALL OUTLINE INTEGRATED CIRCUIT

This image is a representation of the package family, actual package may vary.  
Refer to the product data sheet for package details.



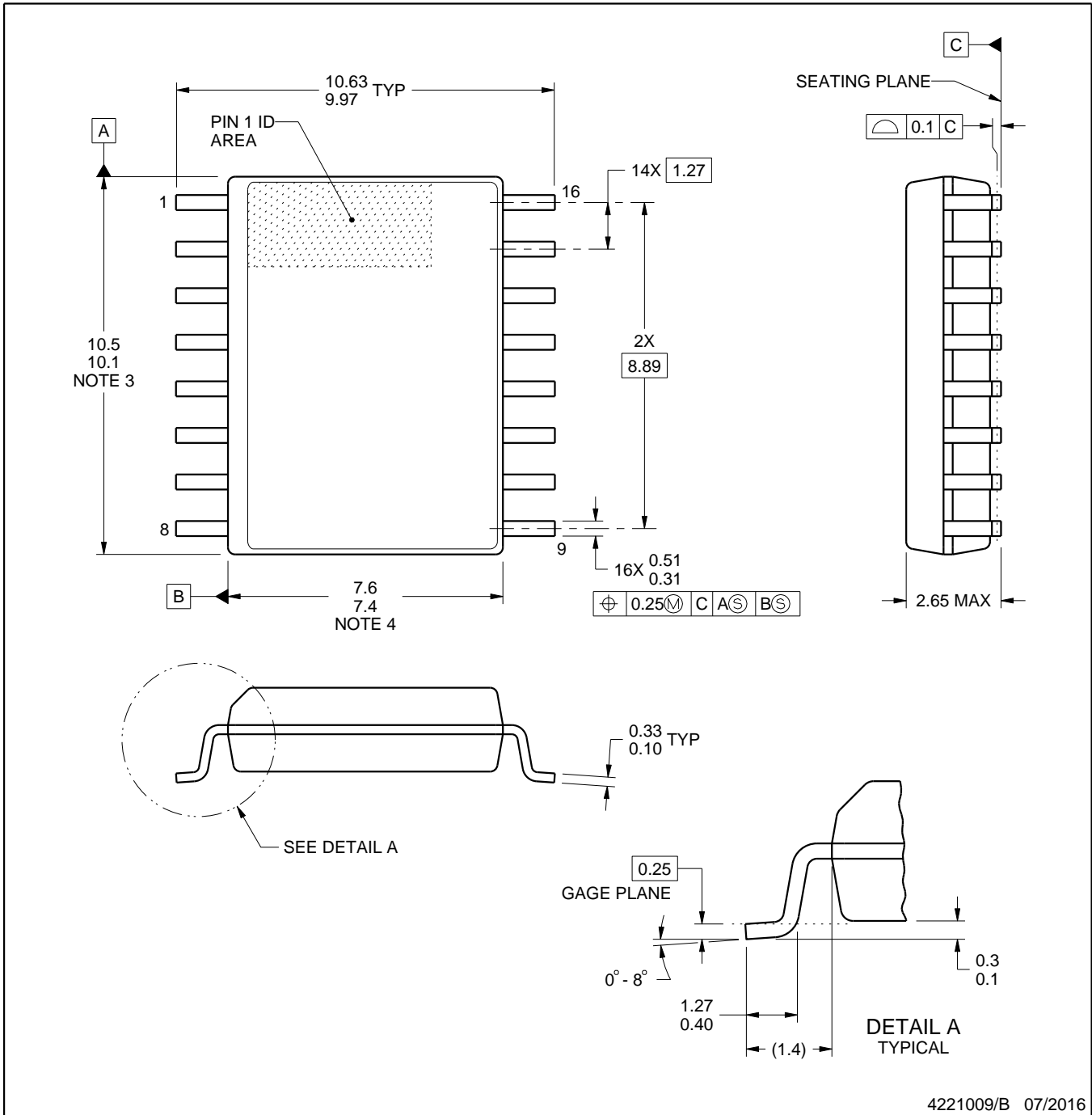
4224780/A



# DW0016B

# PACKAGE OUTLINE SOIC - 2.65 mm max height

SOIC



### NOTES:

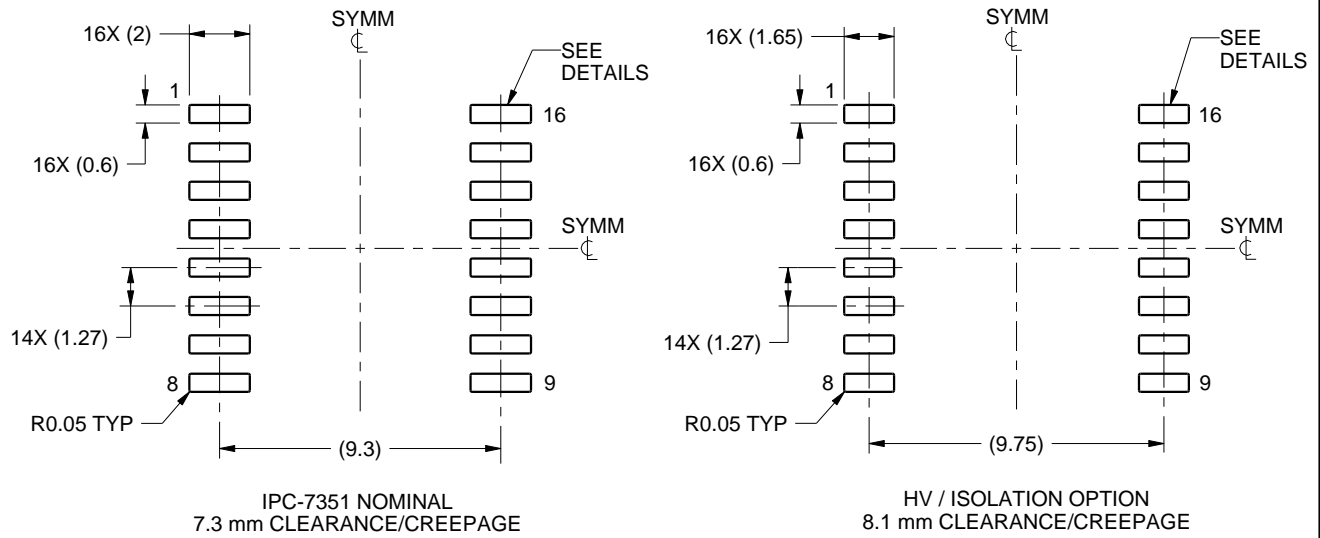
1. All linear dimensions are in millimeters. Dimensions in parenthesis are for reference only. Dimensioning and tolerancing per ASME Y14.5M.
2. This drawing is subject to change without notice.
3. This dimension does not include mold flash, protrusions, or gate burrs. Mold flash, protrusions, or gate burrs shall not exceed 0.15 mm, per side.
4. This dimension does not include interlead flash. Interlead flash shall not exceed 0.25 mm, per side.
5. Reference JEDEC registration MS-013.

# EXAMPLE BOARD LAYOUT

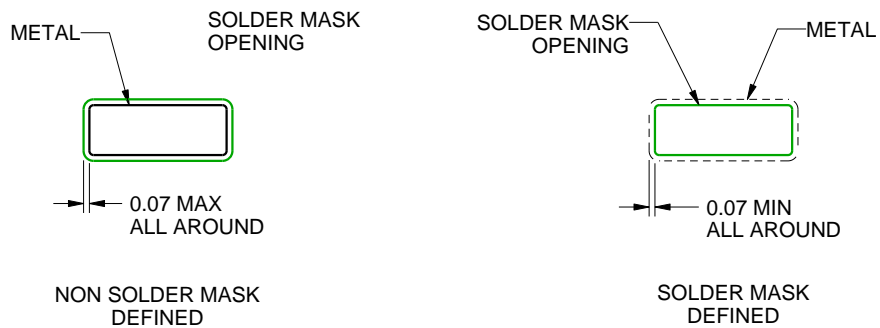
DW0016B

SOIC - 2.65 mm max height

SOIC



LAND PATTERN EXAMPLE  
SCALE:4X



SOLDER MASK DETAILS

4221009/B 07/2016

NOTES: (continued)

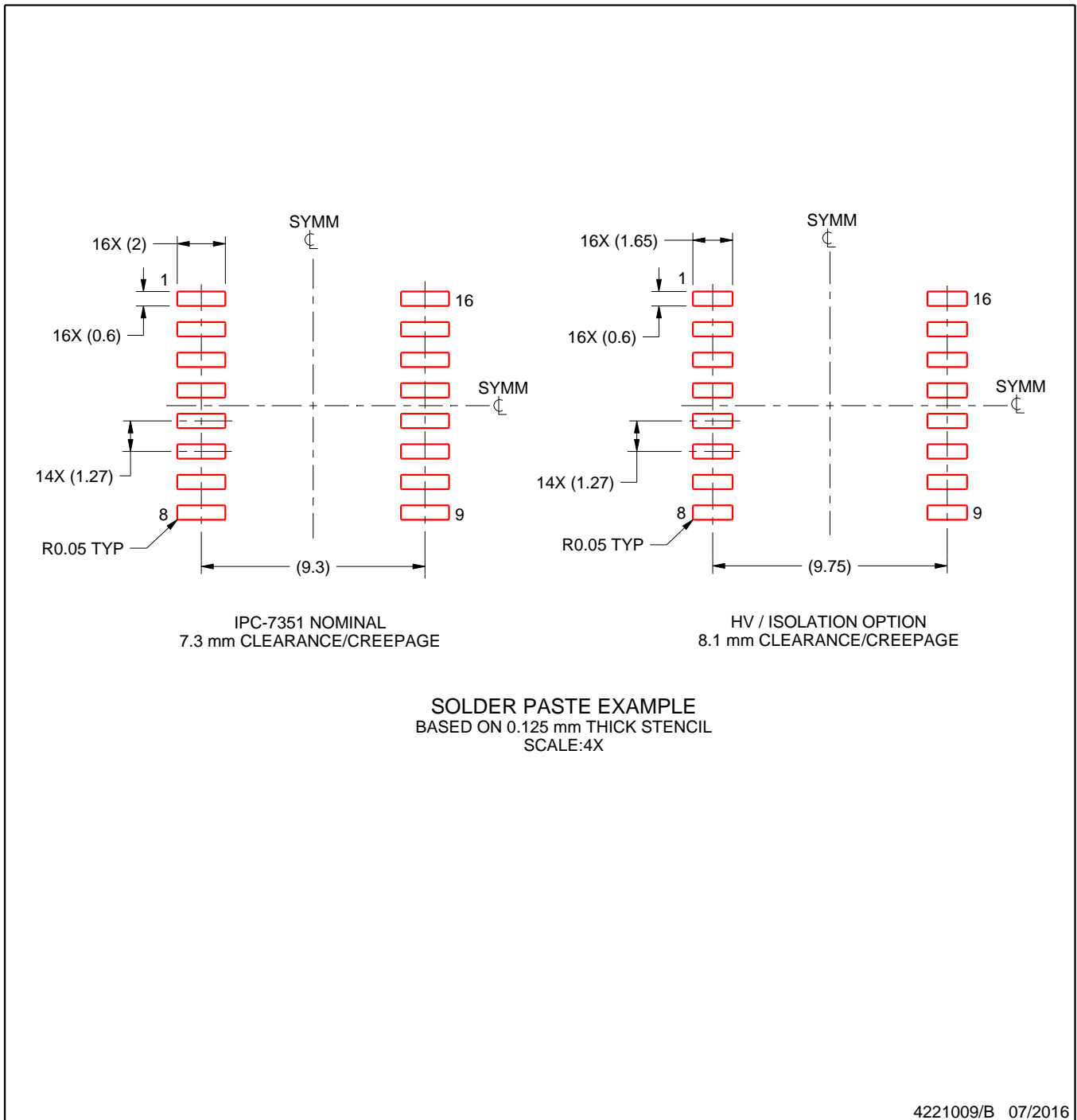
- 6. Publication IPC-7351 may have alternate designs.
- 7. Solder mask tolerances between and around signal pads can vary based on board fabrication site.

# EXAMPLE STENCIL DESIGN

DW0016B

SOIC - 2.65 mm max height

SOIC



NOTES: (continued)

8. Laser cutting apertures with trapezoidal walls and rounded corners may offer better paste release. IPC-7525 may have alternate design recommendations.
9. Board assembly site may have different recommendations for stencil design.

## IMPORTANT NOTICE AND DISCLAIMER

TI PROVIDES TECHNICAL AND RELIABILITY DATA (INCLUDING DATASHEETS), DESIGN RESOURCES (INCLUDING REFERENCE DESIGNS), APPLICATION OR OTHER DESIGN ADVICE, WEB TOOLS, SAFETY INFORMATION, AND OTHER RESOURCES "AS IS" AND WITH ALL FAULTS, AND DISCLAIMS ALL WARRANTIES, EXPRESS AND IMPLIED, INCLUDING WITHOUT LIMITATION ANY IMPLIED WARRANTIES OF MERCHANTABILITY, FITNESS FOR A PARTICULAR PURPOSE OR NON-INFRINGEMENT OF THIRD PARTY INTELLECTUAL PROPERTY RIGHTS.

These resources are intended for skilled developers designing with TI products. You are solely responsible for (1) selecting the appropriate TI products for your application, (2) designing, validating and testing your application, and (3) ensuring your application meets applicable standards, and any other safety, security, regulatory or other requirements.

These resources are subject to change without notice. TI grants you permission to use these resources only for development of an application that uses the TI products described in the resource. Other reproduction and display of these resources is prohibited. No license is granted to any other TI intellectual property right or to any third party intellectual property right. TI disclaims responsibility for, and you fully indemnify TI and its representatives against any claims, damages, costs, losses, and liabilities arising out of your use of these resources.

TI's products are provided subject to [TI's Terms of Sale](#), [TI's General Quality Guidelines](#), or other applicable terms available either on [ti.com](#) or provided in conjunction with such TI products. TI's provision of these resources does not expand or otherwise alter TI's applicable warranties or warranty disclaimers for TI products. Unless TI explicitly designates a product as custom or customer-specified, TI products are standard, catalog, general purpose devices.

TI objects to and rejects any additional or different terms you may propose.

Copyright © 2026, Texas Instruments Incorporated

Last updated 10/2025