

ISO7710 High Speed, Robust EMC Reinforced Single-Channel Digital Isolator

1 Features

- 100Mbps data rate
- Robust isolation barrier:
 - >30-year projected lifetime at 1500V_{RMS} working voltage
 - Up to 5000V_{RMS} isolation rating
 - Up to 12.8kV surge capability
 - ±100kV/μs typical CMTI
- Wide supply range: 2.25V to 5.5V
- 2.25V to 5.5V Level translation
- Default output *high* (ISO7710) and *low* (ISO7710F) options
- Wide temperature range: –55°C to 125°C
- Low power consumption, typical 1.7mA at 1Mbps
- Low propagation delay: 11ns Typical (5V Supplies)
- Robust electromagnetic compatibility (EMC)
 - System-level ESD, EFT, and surge immunity
 - ±8kV IEC 61000-4-2 contact discharge protection across isolation barrier
 - Low emissions
- Wide-SOIC (DW-16) and narrow-SOIC (D-8) package options
- Automotive version available: [ISO7710-Q1](#)
- Safety-related Certifications
 - VDE reinforced insulation per DIN EN IEC 60747-17 (VDE 0884-17)
 - UL 1577 component recognition program
 - IEC 62368-1, IEC 61010-1, IEC 60601-1 and GB 4943.1 certifications

2 Applications

- [Industrial automation](#)
- [Motor control](#)
- [Power supplies](#)
- [Solar inverters](#)
- [Medical equipment](#)

3 Description

The ISO7710 device is a high-performance, single-channel digital isolator with 5000V_{RMS} (DW package) and 3000V_{RMS} (D package) isolation ratings per UL 1577. This device is also certified by VDE, TUV, CSA, and CQC.

The ISO7710 device provides high electromagnetic immunity and low emissions at low power consumption, while isolating CMOS or LVCMOS digital I/Os. The isolation channel has a logic input and output buffer separated by a double capacitive silicon dioxide (SiO₂) insulation barrier. In the event of input power or signal loss, default output is *high* for a device without suffix F and *low* for a device with suffix F. See the [Device Functional Modes](#) section for further details.

Used in conjunction with isolated power supplies, the device helps prevent noise currents on data buses, such as RS-485, RS-232, and CAN, or other circuits from entering the local ground and interfering with or damaging sensitive circuitry. Through innovative chip design and layout techniques, the electromagnetic compatibility of the ISO7710 device has been significantly enhanced to ease system-level ESD, EFT, surge, and emissions compliance. The ISO7710 device is available in 16-pin SOIC wide-body (DW) and 8-pin SOIC narrow-body (D) packages.

Device Information

PART NUMBER	PACKAGE ⁽¹⁾	PACKAGE SIZE ⁽²⁾	BODY SIZE (NOM)
ISO7710	SOIC (D)	4.90mm × 6mm	4.90mm × 3.91mm
	SOIC (DW)	10.30mm × 10.30mm	10.30mm × 7.50mm

(1) For more information, see [Section 11](#).

(2) The package size (length × width) is a nominal value and includes pins, where applicable.

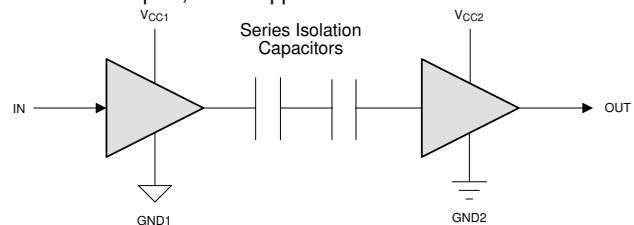

Copyright © 2019, Texas Instruments Incorporated

Simplified Schematic



Table of Contents

1 Features	1	5.18 Insulation Characteristics Curves.....	15
2 Applications	1	5.19 Typical Characteristics.....	16
3 Description	1	6 Parameter Measurement Information	17
4 Pin Configuration and Functions	3	7 Detailed Description	18
Pin Functions.....	3	7.1 Overview.....	18
5 Specifications	4	7.2 Functional Block Diagram.....	18
5.1 Absolute Maximum Ratings.....	5	7.3 Feature Description.....	19
5.2 ESD Ratings.....	5	7.4 Device Functional Modes.....	20
5.3 Recommended Operating Conditions.....	6	8 Application and Implementation	21
5.4 Thermal Information.....	7	8.1 Application Information.....	21
5.5 Power Ratings.....	7	8.2 Typical Application.....	21
5.6 Insulation Specifications.....	8	8.3 Power Supply Recommendations.....	24
5.7 Safety-Related Certifications.....	9	8.4 Layout.....	24
5.8 Safety Limiting Values.....	10	9 Device and Documentation Support	26
5.9 Electrical Characteristics—5-V Supply.....	11	9.1 Documentation Support.....	26
5.10 Supply Current Characteristics—5-V Supply.....	11	9.2 Receiving Notification of Documentation Updates.....	26
5.11 Electrical Characteristics—3.3-V Supply.....	12	9.3 Support Resources.....	26
5.12 Supply Current Characteristics—3.3-V Supply.....	12	9.4 Trademarks.....	26
5.13 Electrical Characteristics—2.5-V Supply.....	13	9.5 Electrostatic Discharge Caution.....	26
5.14 Supply Current Characteristics—2.5-V Supply.....	13	9.6 Glossary.....	26
5.15 Switching Characteristics—5-V Supply.....	14	10 Revision History	26
5.16 Switching Characteristics—3.3-V Supply.....	14	11 Mechanical, Packaging, and Orderable Information	28
5.17 Switching Characteristics—2.5-V Supply.....	15		

4 Pin Configuration and Functions

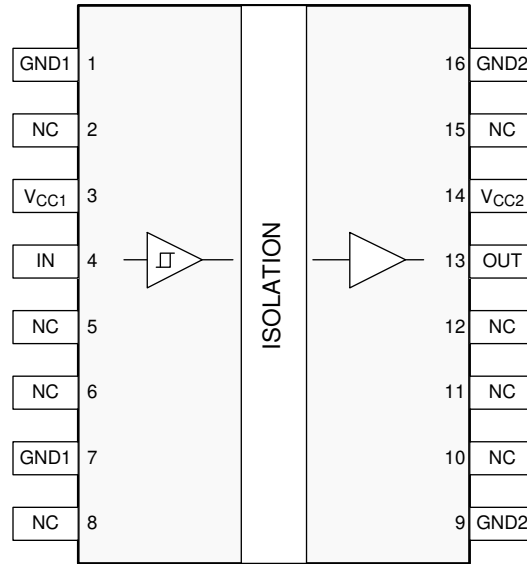

Figure 4-1. DW Package 16-Pin SOIC Top View

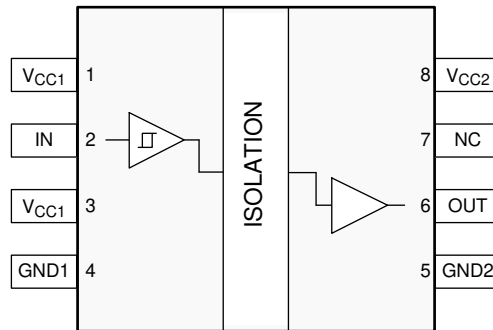

Figure 4-2. D Package 8-Pin SOIC Top View

Pin Functions

NAME	PIN NO.		Type ⁽¹⁾	DESCRIPTION
	DW	D		
V _{CC1}	3	1, 3	—	Power supply, V _{CC1}
V _{CC2}	14	8	—	Power supply, V _{CC2}
GND1	1, 7	4	—	Ground connection for V _{CC1}
GND2	9, 16	5	—	Ground connection for V _{CC2}
IN	4	2	I	Input channel
OUT	13	6	O	Output channel
NC	2, 5, 6, 8, 10, 11, 12, 15	7	—	Not connected. Pin has not internal connection

(1) I = Input, O = Output

5 Specifications

5.1 Absolute Maximum Ratings

See⁽¹⁾

		MIN	MAX	UNIT
V_{CC1}, V_{CC2}	Supply Voltage ⁽²⁾	-0.5	6	V
V	Voltage at INx, OUTx	-0.5	$V_{CCX} + 0.5$ ⁽³⁾	V
I_O	Output current	-15	15	mA
T_J	Junction temperature		150	°C
T_{stg}	Storage temperature	-65	150	°C

- (1) Operation outside the Absolute Maximum Ratings may cause permanent device damage. Absolute Maximum Ratings do not imply functional operation of the device at these or any other conditions beyond those listed under Recommended Operating Conditions. If used outside the Recommended Operating Conditions but within the Absolute Maximum Ratings, the device may not be fully functional, and this may affect device reliability, functionality, performance, and shorten the device lifetime.
- (2) All voltage values except differential I/O bus voltages are with respect to the local ground terminal (GND1 or GND2) and are peak voltage values
- (3) Maximum voltage must not exceed 6 V.

5.2 ESD Ratings

			VALUE	UNIT
V_{ESD}	Electrostatic discharge	Human body model (HBM), per ANSI/ESDA/JEDEC JS-001, all pins ⁽¹⁾	±6000	V
		Charged device model (CDM), per JEDEC specification JESD22-C101, all pins ⁽²⁾	±1500	
		Contact discharge per IEC 61000-4-2; Isolation barrier withstand test ^{(3) (4)}	±8000	

- (1) JEDEC document JEP155 states that 500-V HBM allows safe manufacturing with a standard ESD control process.
- (2) JEDEC document JEP157 states that 250-V CDM allows safe manufacturing with a standard ESD control process.
- (3) IEC ESD strike is applied across the barrier with all pins on each side tied together creating a two-terminal device.
- (4) Testing is carried out in air or oil to determine the intrinsic contact discharge capability of the device.

5.3 Recommended Operating Conditions

		MIN	NOM	MAX	UNIT
V_{CC1}, V_{CC2}	Supply voltage	2.25		5.5	V
$V_{CC(UVLO+)}$	UVLO threshold when supply voltage is rising		2	2.25	V
$V_{CC(UVLO-)}$	UVLO threshold when supply voltage is falling	1.7	1.8		V
$V_{HYS(UVLO)}$	Supply voltage UVLO hysteresis	100	200		mV
I_{OH}	High level output current	$V_{CC2} = 5\text{ V}$		-4	mA
		$V_{CC2} = 3.3\text{ V}$		-2	
		$V_{CC2} = 2.5\text{ V}$		-1	
I_{OL}	Low level output current	$V_{CC2} = 5\text{ V}$		4	mA
		$V_{CC2} = 3.3\text{ V}$		2	
		$V_{CC2} = 2.5\text{ V}$		1	
V_{IH}	High level Input voltage	$0.7 \times V_{CC1}$		V_{CC1}	V
V_{IL}	Low level Input voltage	0		$0.3 \times V_{CC1}$	V
$DR^{(1)}$	Data Rate	0		100	Mbps
T_A	Ambient temperature	-55	25	125	°C

(1) 100 Mbps is the maximum specified data rate, although higher data rates are possible.

5.4 Thermal Information

THERMAL METRIC ⁽¹⁾		ISO7710		UNIT
		DW (SOIC)	D(SOIC)	
		(16-Pin)	(8-Pin)	
$R_{\theta JA}$	Junction-to-ambient thermal resistance	94.4	146.1	°C/W
$R_{\theta JC(top)}$	Junction-to-case (top) thermal resistance	57.3	63.1	°C/W
$R_{\theta JB}$	Junction-to-board thermal resistance	57.1	80.0	°C/W
Ψ_{JT}	Junction-to-top characterization parameter	40.0	9.6	°C/W
Ψ_{JB}	Junction-to-board characterization parameter	56.8	79.0	°C/W
$R_{\theta JC(bot)}$	Junction-to-case (bottom) thermal resistance	—	—	°C/W

(1) For more information about traditional and new thermal metrics, see the [Semiconductor and IC Package Thermal Metrics](#) application note

5.5 Power Ratings

PARAMETER		TEST CONDITIONS	MIN	TYP	MAX	UNIT
ISO7710						
P_D	Maximum power dissipation (both sides)	$V_{CC1} = V_{CC2} = 5.5\text{ V}$, $T_J = 150^\circ\text{C}$, $C_L = 15\text{ pF}$, Input a 50-MHz 50% duty cycle square wave			55	mW
P_{D1}	Maximum power dissipation (side-1)				13	mW
P_{D2}	Maximum power dissipation (side-2)				42	mW

5.6 Insulation Specifications

PARAMETER		TEST CONDITIONS	VALUE		UNIT
			DW-16	D-8	
IEC 60664-1					
CLR	External clearance ⁽¹⁾	Shortest terminal-to-terminal distance through air	8	4	mm
CPG	External creepage ⁽¹⁾	Shortest terminal-to-terminal distance across the package surface	8	4	mm
DTI	Distance through the insulation	Minimum internal gap (internal clearance)	17	17	μm
CTI	Comparative tracking index	DIN EN 60112 (VDE 0303-11); IEC 60112; UL 746A	>600	>600	V
	Material Group	According to IEC 60664-1	I	I	
	Overvoltage category per IEC 60664-1	Rated mains voltage ≤ 150 V _{RMS}	I-IV	I-IV	
		Rated mains voltage ≤ 300 V _{RMS}	I-IV	I-III	
		Rated mains voltage ≤ 600 V _{RMS}	I-IV	n/a	
		Rated mains voltage ≤ 1000 V _{RMS}	I-III	n/a	
DIN EN IEC 60747-17 (VDE 0884-17)⁽²⁾					
V _{IORM}	Maximum repetitive peak isolation voltage	AC voltage (bipolar)	2121	637	V _{PK}
V _{IOWM}	Maximum working isolation voltage	AC voltage; time-dependent dielectric breakdown (TDDB) test, see Section 8.2.3.1	1500	450	V _{RMS}
		DC voltage	2121	637	V _{DC}
V _{IOTM}	Maximum transient isolation voltage	V _{TEST} = V _{IOTM} , t = 60 s (qualification); V _{TEST} = 1.2 × V _{IOTM} , t = 1 s (100% production)	8000	4242	V _{PK}
V _{IMP}	Maximum impulse voltage ⁽³⁾	Tested in air, 1.2/50-μs waveform per IEC 62368-1	8000	5000	V _{PK}
V _{IOSM}	Maximum surge isolation voltage ⁽⁴⁾	V _{IOSM} ≥ 1.3 × V _{IMP} ; Tested in oil (qualification test), 1.2/50-μs waveform per IEC 62368-1	12800	10000	V _{PK}
Q _{pd}	Apparent charge ⁽⁵⁾	Method a: After I/O safety test subgroup 2/3, V _{ini} = V _{IOTM} , t _{ini} = 60 s; V _{pd(m)} = 1.2 × V _{IORM} , t _m = 10 s	≤ 5	≤ 5	pC
		Method a: After environmental tests subgroup 1, V _{ini} = V _{IOTM} , t _{ini} = 60 s; V _{pd(m)} = 1.6 × V _{IORM} , t _m = 10 s	≤ 5	≤ 5	
		Method b: At routine test (100% production) and preconditioning (type test); V _{ini} = 1.2 × V _{IOTM} , t _{ini} = 1 s; V _{pd(m)} = 1.875 × V _{IORM} (ISO7710), t _m = 1 s (method b1) or V _{pd(m)} = V _{ini} , t _m = t _{ini} (method b2)	≤ 5	≤ 5	
C _{IO}	Barrier capacitance, input to output ⁽⁶⁾	V _{IO} = 0.4 × sin(2πft), f = 1 MHz	≈0.4	≈0.4	pF
R _{IO}	Insulation resistance ⁽⁶⁾	V _{IO} = 500 V, T _A = 25°C	> 10 ¹²	> 10 ¹²	Ω
		V _{IO} = 500 V, 100°C ≤ T _A ≤ 125°C	> 10 ¹¹	> 10 ¹¹	
		V _{IO} = 500 V at T _S = 150°C	> 10 ⁹	> 10 ⁹	
	Pollution degree		2	2	
	Climatic category		55/125/ 21	55/125/ 21	
UL 1577					
V _{ISO}	Withstand isolation voltage	V _{TEST} = V _{ISO} , t = 60 s (qualification); V _{TEST} = 1.2 × V _{ISO} , t = 1 s (100% production)	5000	3000	V _{RMS}

- Creepage and clearance requirements should be applied according to the specific equipment isolation standards of an application. Care must be taken to maintain the creepage and clearance distance of a board design to verify that the mounting pads of the isolator on the printed-circuit board do not reduce this distance. Creepage and clearance on a printed-circuit board become equal in certain cases. Techniques such as inserting grooves, ribs, or both on a printed circuit board are used to help increase these specifications.
- This coupler is designed for *safe electrical insulation* only within the safety ratings. Compliance with the safety ratings shall be ensured by means of suitable protective circuits.
- Testing is carried out in air to determine the surge immunity of the package

- (4) Testing is carried out in oil to determine the intrinsic surge immunity of the isolation barrier.
- (5) Apparent charge is electrical discharge caused by a partial discharge (pd).
- (6) All pins on each side of the barrier tied together creating a two-terminal device.

5.7 Safety-Related Certifications

VDE	CSA	UL	CQC	TUV
Certified according to DIN EN IEC 60747-17 (VDE 0884-17)	Certified according to IEC 62368-1 and IEC 60601-1	Certified according to UL 1577 Component Recognition Program	Certified according to GB4943.1	Certified according to EN 61010-1 and EN 62368-1
Maximum transient isolation voltage, 8000 V _{PK} (DW-16, Reinforced) and 4242 V _{PK} (D-8); Maximum repetitive peak isolation voltage, 2121 V _{PK} (DW-16, Reinforced) and 637 V _{PK} (D-8); Maximum surge isolation voltage, 12800 V _{PK} (DW-16, Reinforced) and 10000 V _{PK} (D-8)	Reinforced insulation per CSA 62368-1 and IEC 62368-1, 800 V _{RMS} (DW-16) and 400 V _{RMS} (D-8) max working voltage (pollution degree 2, material group I); 2 MOPP (Means of Patient Protection) per CSA 60601-1 and IEC 60601-1, 250 V _{RMS} (DW-16) max working voltage	DW-16: Single protection, 5000 V _{RMS} ; D-8: Single protection, 3000 V _{RMS}	DW-16: Reinforced Insulation, Altitude ≤ 5000 m, Tropical Climate, 700 V _{RMS} maximum working voltage; D-8: Basic Insulation, Altitude ≤ 5000 m, Tropical Climate, 400 V _{RMS} maximum working voltage	5000 V _{RMS} (DW-16) and 3000 V _{RMS} (D-8) Reinforced insulation per EN 61010-1 up to working voltage of 600 V _{RMS} (DW-16) and 300 V _{RMS} (D-8) 5000 V _{RMS} (DW-16) and 3000 V _{RMS} (D-8) Reinforced insulation per EN 62368-1 up to working voltage of 800 V _{RMS} (DW-16) and 400 V _{RMS} (D-8)
Certificate number: 40040142	Master contract number: 220991	File number: E181974	Certificate numbers: CQC21001304083 (DW-16) CQC15001121656 (D-8)	Client ID number: 77311

5.8 Safety Limiting Values

Safety limiting⁽¹⁾ intends to minimize potential damage to the isolation barrier upon failure of input or output circuitry. A failure of the I/O can allow low resistance to ground or the supply and, without current limiting, dissipate sufficient power to overheat the die and damage the isolation barrier potentially leading to secondary system failures.

PARAMETER		TEST CONDITIONS	MIN	TYP	MAX	UNIT
DW-16 PACKAGE						
I _S	Safety input, output, or supply current	R _{θJA} = 94.4°C/W, V _I = 5.5 V, T _J = 150°C, T _A = 25°C, see Figure 5-1			241	mA
		R _{θJA} = 94.4°C/W, V _I = 3.6 V, T _J = 150°C, T _A = 25°C, see Figure 5-1			368	
		R _{θJA} = 94.4°C/W, V _I = 2.75 V, T _J = 150°C, T _A = 25°C, see Figure 5-1			482	
P _S	Safety input, output, or total power	R _{θJA} = 94.4°C/W, T _J = 150°C, T _A = 25°C, see Figure 5-2			1324	mW
T _S	Maximum safety temperature				150	°C
D-8 PACKAGE						
I _S	Safety input, output, or supply current ⁽¹⁾	R _{θJA} = 146.1°C/W, V _I = 5.5 V, T _J = 150°C, T _A = 25°C, see Figure 5-3			156	mA
		R _{θJA} = 146.1°C/W, V _I = 3.6 V, T _J = 150°C, T _A = 25°C, see Figure 5-3			238	
		R _{θJA} = 146.1°C/W, V _I = 2.75 V, T _J = 150°C, T _A = 25°C, see Figure 5-3			311	
P _S	Safety input, output, or total power ⁽¹⁾	R _{θJA} = 146.1°C/W, T _J = 150°C, T _A = 25°C, see Figure 5-4			856	mW
T _S	Maximum safety temperature ⁽¹⁾				150	°C

- (1) The maximum safety temperature, T_S, has the same value as the maximum junction temperature, T_J, specified for the device. The I_S and P_S parameters represent the safety current and safety power respectively. The maximum limits of I_S and P_S should not be exceeded. These limits vary with the ambient temperature, T_A.
 The junction-to-air thermal resistance, R_{θJA}, in the [Section 5.4](#) table is that of a device installed on a high-K test board for leaded surface-mount packages. Use these equations to calculate the value for each parameter:
 $T_J = T_A + R_{\theta JA} \times P$, where P is the power dissipated in the device.
 $T_{J(max)} = T_S = T_A + R_{\theta JA} \times P_S$, where T_{J(max)} is the maximum allowed junction temperature.
 $P_S = I_S \times V_I$, where V_I is the maximum input voltage.

5.9 Electrical Characteristics—5-V Supply

$V_{CC1} = V_{CC2} = 5\text{ V} \pm 10\%$ (over recommended operating conditions unless otherwise noted)

PARAMETER		TEST CONDITIONS	MIN	TYP	MAX	UNIT
V_{OH}	High-level output voltage	$I_{OH} = -4\text{ mA}$; see Figure 6-1	$V_{CC2} - 0.4$	4.8		V
V_{OL}	Low-level output voltage	$I_{OL} = 4\text{ mA}$; see Figure 6-1		0.2	0.4	V
$V_{IT+(IN)}$	Rising input threshold voltage			$0.6 \times V_{CC1}$	$0.7 \times V_{CC1}$	V
$V_{IT-(IN)}$	Falling input threshold voltage		$0.3 \times V_{CC1}$	$0.4 \times V_{CC1}$		V
$V_{I(HYS)}$	Input threshold voltage hysteresis		$0.1 \times V_{CC1}$	$0.2 \times V_{CC1}$		V
I_{IH}	High-level input current	$V_{IH} = V_{CC1}$ at INx			10	μA
I_{IL}	Low-level input current	$V_{IL} = 0\text{ V}$ at INx	-10			μA
CMTI	Common mode transient immunity	$V_I = V_{CC1}$ or 0 V , $V_{CM} = 1200\text{ V}$; see Figure 6-3	85	100		kV/ μs
C_I	Input Capacitance ⁽¹⁾	$V_I = V_{CC}/2 + 0.4 \times \sin(2\pi ft)$, $f = 1\text{ MHz}$, $V_{CC} = 5\text{ V}$;		2		pF

(1) Measured from input pin to same side ground.

5.10 Supply Current Characteristics—5-V Supply

$V_{CC1} = V_{CC2} = 5\text{ V} \pm 10\%$ (over recommended operating conditions unless otherwise noted)

PARAMETER	TEST CONDITIONS	SUPPLY CURRENT	MIN	TYP	MAX	UNIT	
ISO7710							
Supply current - DC signal	$V_I = V_{CC1}$ (ISO7710), $V_I = 0\text{ V}$ (ISO7710 with F suffix)	I_{CC1}		0.5	1.2	mA	
		I_{CC2}		0.6	1.2		
	$V_I = 0\text{ V}$ (ISO7710), $V_I = V_{CC1}$ (ISO7710 with F suffix)	I_{CC1}		1.6	2.4		
		I_{CC2}		0.6	1.2		
Supply current - AC signal	All channels switching with square wave clock input; $C_L = 15\text{ pF}$	1 Mbps	I_{CC1}		1.1		1.8
			I_{CC2}		0.6		1.3
		10 Mbps	I_{CC1}		1.1		1.9
			I_{CC2}		1.1		1.9
		100 Mbps	I_{CC1}		1.4	2.3	
			I_{CC2}		5.9	7.4	

5.11 Electrical Characteristics—3.3-V Supply

$V_{CC1} = V_{CC2} = 3.3 \text{ V} \pm 10\%$ (over recommended operating conditions unless otherwise noted)

PARAMETER		TEST CONDITIONS	MIN	TYP	MAX	UNIT
V_{OH}	High-level output voltage	$I_{OH} = -2\text{mA}$; see Figure 6-1	$V_{CC2} - 0.3$	3.2		V
V_{OL}	Low-level output voltage	$I_{OL} = 2\text{mA}$; see Figure 6-1		0.1	0.3	V
$V_{IT+(IN)}$	Rising input threshold voltage			$0.6 \times V_{CC1}$	$0.7 \times V_{CC1}$	V
$V_{IT-(IN)}$	Falling input threshold voltage		$0.3 \times V_{CC1}$	$0.4 \times V_{CC1}$		V
$V_{I(HYS)}$	Input threshold voltage hysteresis		$0.1 \times V_{CC1}$	$0.2 \times V_{CC1}$		V
I_{IH}	High-level input current	$V_{IH} = V_{CC1}$ at INx			10	μA
I_{IL}	Low-level input current	$V_{IL} = 0 \text{ V}$ at INx	-10			μA
CMTI	Common mode transient immunity	$V_I = V_{CC1}$ or 0 V , $V_{CM} = 1200 \text{ V}$; see Figure 6-3	85	100		$\text{kV}/\mu\text{s}$

5.12 Supply Current Characteristics—3.3-V Supply

$V_{CC1} = V_{CC2} = 3.3 \text{ V} \pm 10\%$ (over recommended operating conditions unless otherwise noted)

PARAMETER	TEST CONDITIONS	SUPPLY CURRENT	MIN	TYP	MAX	UNIT	
ISO7710							
Supply current - DC signal	$V_I = V_{CC1}$ (ISO7710), $V_I = 0 \text{ V}$ (ISO7710 with F suffix)	I_{CC1}		0.5	1.2	mA	
		I_{CC2}		0.6	1.1		
	$V_I = 0 \text{ V}$ (ISO7710), $V_I = V_{CC1}$ (ISO7710with F suffix)	I_{CC1}		1.6	2.4		
		I_{CC2}		0.6	1.2		
Supply current - AC signal	All channels switching with square wave clock input; $C_L = 15 \text{ pF}$	1 Mbps	I_{CC1}		1.1		1.8
			I_{CC2}		0.6		1.2
		10 Mbps	I_{CC1}		1		1.8
			I_{CC2}		1.1		1.7
		100 Mbps	I_{CC1}		1.3	2.1	
			I_{CC2}		4.3	5.6	

5.13 Electrical Characteristics—2.5-V Supply

$V_{CC1} = V_{CC2} = 2.5\text{ V} \pm 10\%$ (over recommended operating conditions unless otherwise noted)

PARAMETER		TEST CONDITIONS	MIN	TYP	MAX	UNIT
V_{OH}	High-level output voltage	$I_{OH} = -1\text{ mA}$; see Figure 6-1	$V_{CC2} - 0.2$	2.45		V
V_{OL}	Low-level output voltage	$I_{OL} = 1\text{ mA}$; see Figure 6-1		0.05	0.2	V
$V_{IT+(IN)}$	Rising input threshold voltage			$0.6 \times V_{CC1}$	$0.7 \times V_{CC1}$	V
$V_{IT-(IN)}$	Falling input threshold voltage		$0.3 \times V_{CC1}$	$0.4 \times V_{CC1}$		V
$V_{I(HYS)}$	Input threshold voltage hysteresis		$0.1 \times V_{CC1}$	$0.2 \times V_{CC1}$		V
I_{IH}	High-level input current	$V_{IH} = V_{CC1}$ at INx			10	μA
I_{IL}	Low-level input current	$V_{IL} = 0\text{ V}$ at INx	-10			μA
CMTI	Common mode transient immunity	$V_I = V_{CC1}$ or 0 V , $V_{CM} = 1200\text{ V}$; see Figure 6-3	85	100		$\text{kV}/\mu\text{s}$

5.14 Supply Current Characteristics—2.5-V Supply

$V_{CC1} = V_{CC2} = 2.5\text{ V} \pm 10\%$ (over recommended operating conditions unless otherwise noted)

PARAMETER	TEST CONDITIONS	SUPPLY CURRENT	MIN	TYP	MAX	UNIT	
ISO7710							
Supply current - DC signal	$V_I = V_{CC1}$ (ISO7710), $V_I = 0\text{ V}$ (ISO7710 with F suffix)	I_{CC1}		0.5	1.2	mA	
		I_{CC2}		0.6	1.1		
	$V_I = 0\text{ V}$ (ISO7710), $V_I = V_{CC1}$ (ISO7710 with F suffix)	I_{CC1}		1.6	2.3		
		I_{CC2}		0.6	1.2		
Supply current - AC signal	All channels switching with square wave clock input; $C_L = 15\text{ pF}$	1 Mbps	I_{CC1}		1.1		1.8
			I_{CC2}		0.6		1.2
		10 Mbps	I_{CC1}		1.1		1.8
			I_{CC2}		0.9		1.5
		100 Mbps	I_{CC1}		1.2	2	
			I_{CC2}		3.4	4.6	

5.15 Switching Characteristics—5-V Supply

$V_{CC1} = V_{CC2} = 5\text{ V} \pm 10\%$ (over recommended operating conditions unless otherwise noted)

PARAMETER		TEST CONDITIONS	MIN	TYP	MAX	UNIT
t_{PLH} , t_{PHL}	Propagation delay time	See Figure 6-1	6	11	17	ns
PWD	Pulse width distortion ⁽¹⁾ $ t_{PHL} - t_{PLH} $					
$t_{sk(pp)}$	Part-to-part skew time ⁽²⁾				4.5	ns
t_r	Output signal rise time	See Figure 6-1		1.8	3.9	ns
t_f	Output signal fall time			1.9	3.9	ns
t_{DO}	Default output delay time from input power loss	Measured from the time V_{CC1} goes below 1.7V. See Figure 6-2		0.1	0.3	μs
t_{ie}	Time interval error	$2^{16} - 1$ PRBS data at 100 Mbps		1		ns

(1) Also known as pulse skew.

(2) $t_{sk(pp)}$ is the magnitude of the difference in propagation delay times between any terminals of different devices switching in the same direction while operating at identical supply voltages, temperature, input signals and loads.

5.16 Switching Characteristics—3.3-V Supply

$V_{CC1} = V_{CC2} = 3.3\text{ V} \pm 10\%$ (over recommended operating conditions unless otherwise noted)

PARAMETER		TEST CONDITIONS	MIN	TYP	MAX	UNIT
t_{PLH} , t_{PHL}	Propagation delay time	See Figure 6-1	6	11	18.5	ns
PWD	Pulse width distortion ⁽¹⁾ $ t_{PHL} - t_{PLH} $					
$t_{sk(pp)}$	Part-to-part skew time ⁽²⁾				4.5	ns
t_r	Output signal rise time	See Figure 6-1		0.7	3	ns
t_f	Output signal fall time			0.7	3	ns
t_{DO}	Default output delay time from input power loss	Measured from the time V_{CC1} goes below 1.7V. See Figure 6-2		0.1	0.3	μs
t_{ie}	Time interval error	$2^{16} - 1$ PRBS data at 100 Mbps		1		ns

(1) Also known as pulse skew.

(2) $t_{sk(pp)}$ is the magnitude of the difference in propagation delay times between any terminals of different devices switching in the same direction while operating at identical supply voltages, temperature, input signals and loads.

5.17 Switching Characteristics—2.5-V Supply

$V_{CC1} = V_{CC2} = 2.5\text{ V} \pm 10\%$ (over recommended operating conditions unless otherwise noted)

PARAMETER		TEST CONDITIONS	MIN	TYP	MAX	UNIT
t_{PLH}, t_{PHL}	Propagation delay time	See Figure 6-1	7.5	12	21	ns
PWD	Pulse width distortion ⁽¹⁾ $ t_{PHL} - t_{PLH} $					
$t_{sk(pp)}$	Part-to-part skew time ⁽²⁾				4.6	ns
t_r	Output signal rise time	See Figure 6-1		1	3.5	ns
t_f	Output signal fall time			1	3.5	ns
t_{DO}	Default output delay time from input power loss	Measured from the time V_{CC1} goes below 1.7V. See Figure 6-2		0.1	0.3	μ s
t_{ie}	Time interval error	$2^{16} - 1$ PRBS data at 100 Mbps		1		ns

- (1) Also known as pulse skew.
- (2) $t_{sk(pp)}$ is the magnitude of the difference in propagation delay times between any terminals of different devices switching in the same direction while operating at identical supply voltages, temperature, input signals and loads.

5.18 Insulation Characteristics Curves

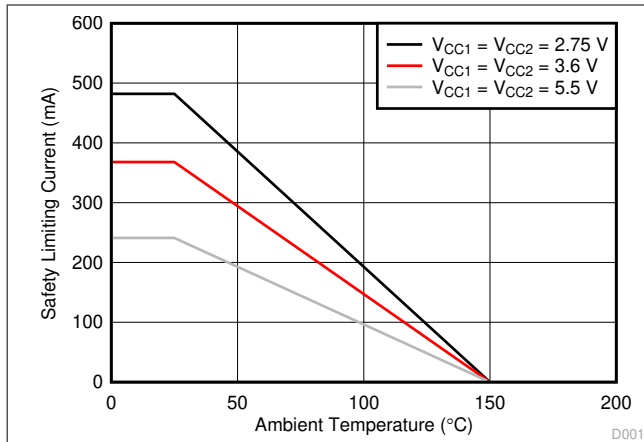

Figure 5-1. Thermal Derating Curve for Limiting Current per VDE for DW-16 Package

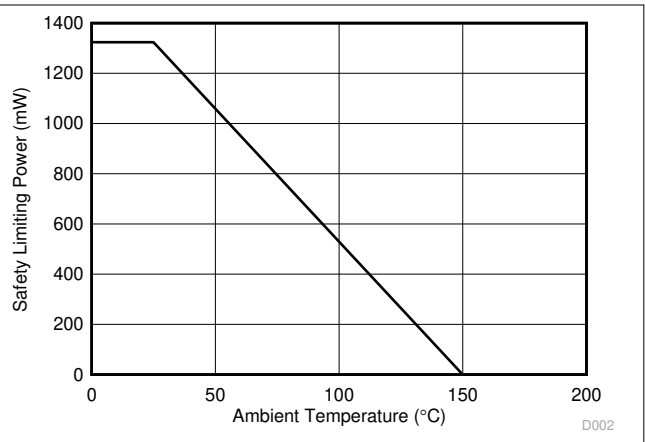

Figure 5-2. Thermal Derating Curve for Limiting Power per VDE for DW-16 Package

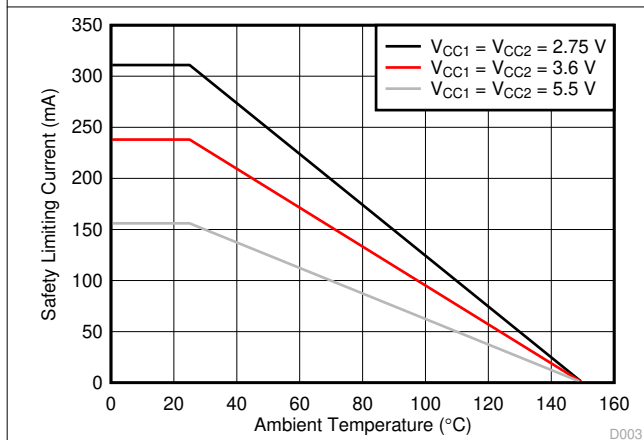

Figure 5-3. Thermal Derating Curve for Limiting Current per VDE for D-8 Package

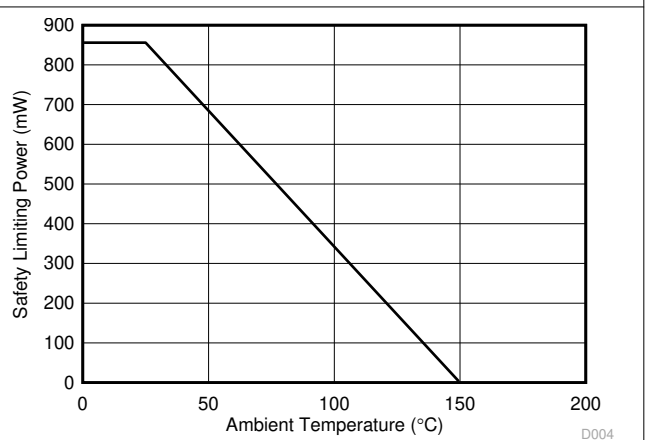

Figure 5-4. Thermal Derating Curve for Limiting Power per VDE for D-8 Package

5.19 Typical Characteristics

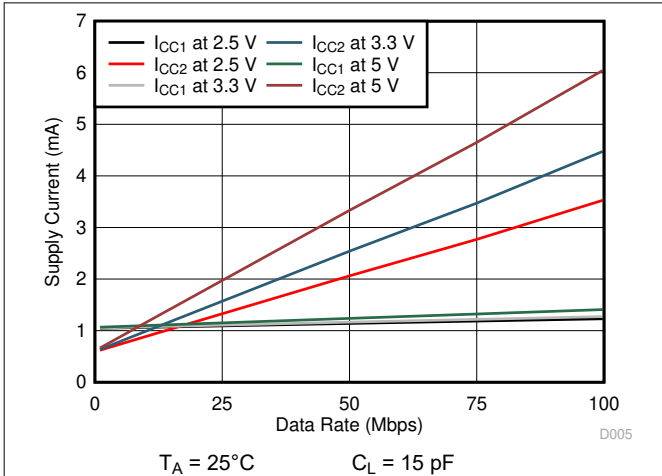

Figure 5-5. ISO7710 Supply Current vs Data Rate (With 15 pF Load)

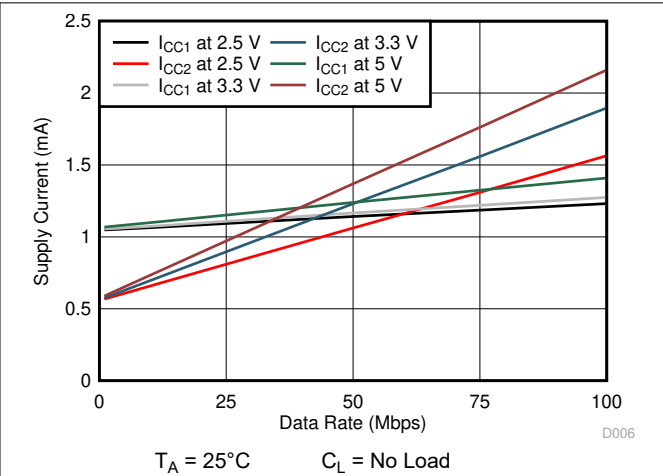

Figure 5-6. ISO7710 Supply Current vs Data Rate (With No Load)

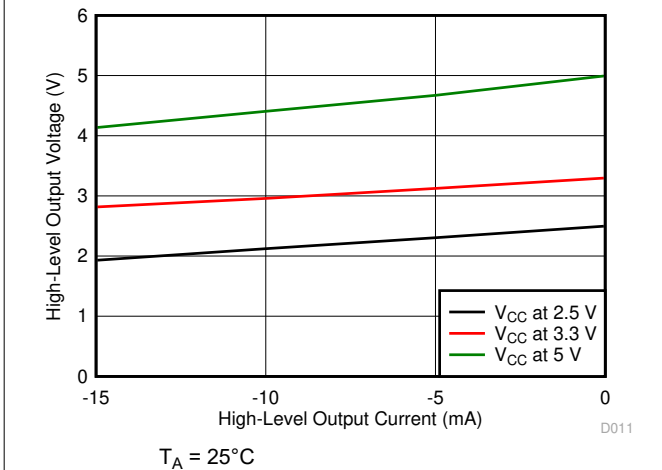

Figure 5-7. High-Level Output Voltage vs High-level Output Current

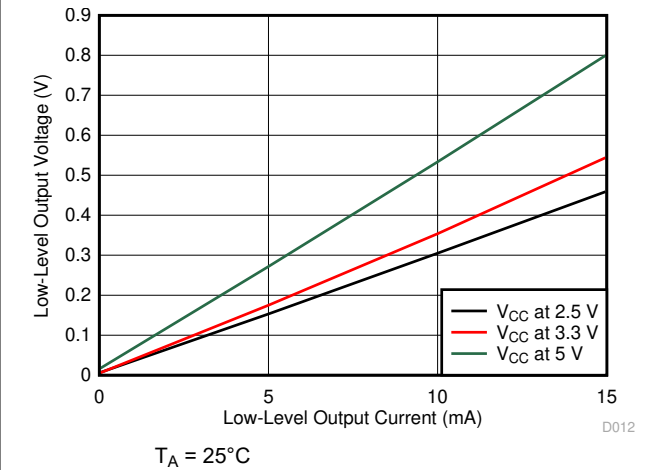

Figure 5-8. Low-Level Output Voltage vs Low-Level Output Current

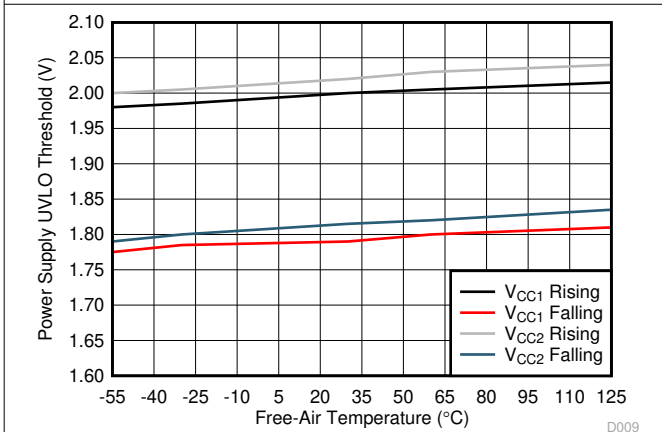

Figure 5-9. Power Supply Undervoltage Threshold vs Free-Air Temperature

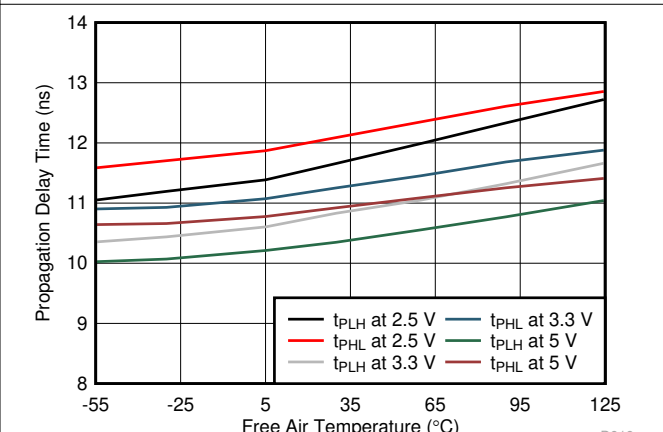
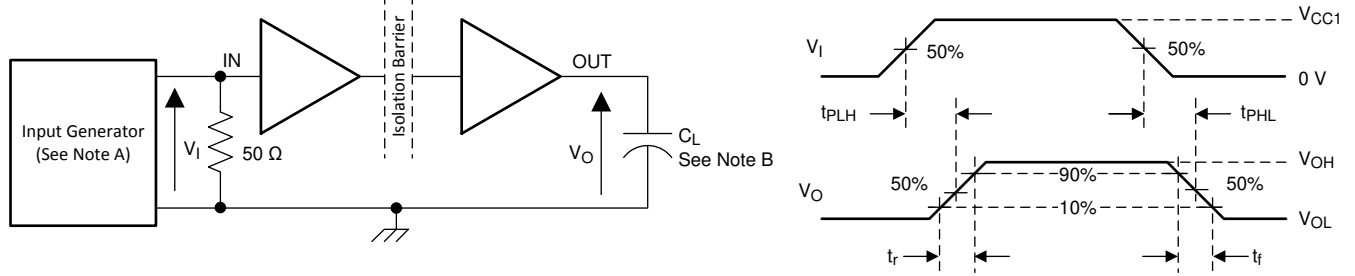

Figure 5-10. Propagation Delay Time vs Free-Air Temperature

6 Parameter Measurement Information



- A. The input pulse is supplied by a generator having the following characteristics: PRR \leq 50 kHz, 50% duty cycle, $t_r \leq$ 3 ns, $t_f \leq$ 3ns, $Z_O = 50\ \Omega$. At the input, $50\ \Omega$ resistor is required to terminate Input Generator signal. The $50\ \Omega$ resistor is not needed in actual application.
- B. $C_L = 15\ \text{pF}$ and includes instrumentation and fixture capacitance within $\pm 20\%$.

Figure 6-1. Switching Characteristics Test Circuit and Voltage Waveforms

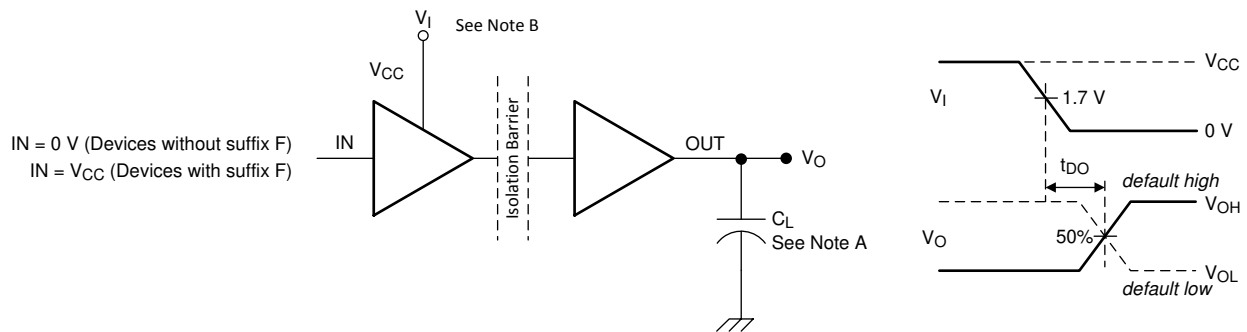

- A. $C_L = 15\ \text{pF}$ and includes instrumentation and fixture capacitance within $\pm 20\%$.
- B. Power Supply Ramp Rate = 10 mV/ns

Figure 6-2. Default Output Delay Time Test Circuit and Voltage Waveforms

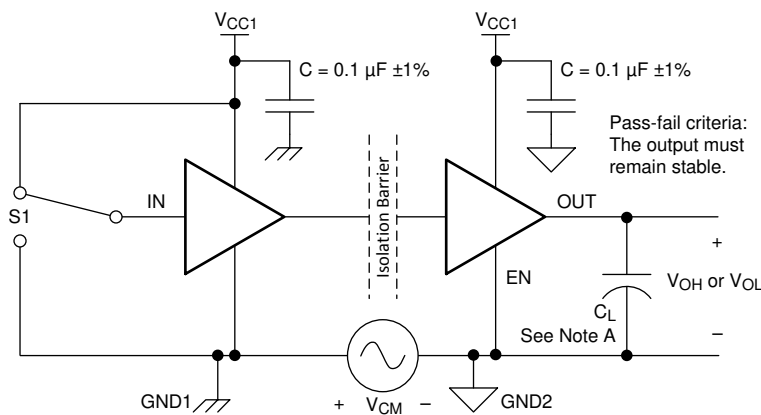

- A. $C_L = 15\ \text{pF}$ and includes instrumentation and fixture capacitance within $\pm 20\%$.

Figure 6-3. Common-Mode Transient Immunity Test Circuit

7 Detailed Description

7.1 Overview

The ISO7710 device has an ON-OFF keying (OOK) modulation scheme to transmit the digital data across a silicon dioxide based isolation barrier. The transmitter sends a high frequency carrier across the barrier to represent one digital state and sends no signal to represent the other digital state. The receiver demodulates the signal after advanced signal conditioning and produces the output through a buffer stage. The device also incorporates advanced circuit techniques to maximize the CMTI performance and minimize the radiated emissions due the high frequency carrier and IO buffer switching. The conceptual block diagram of a digital capacitive isolator, [Figure 7-1](#), shows a functional block diagram of a typical channel.

7.2 Functional Block Diagram

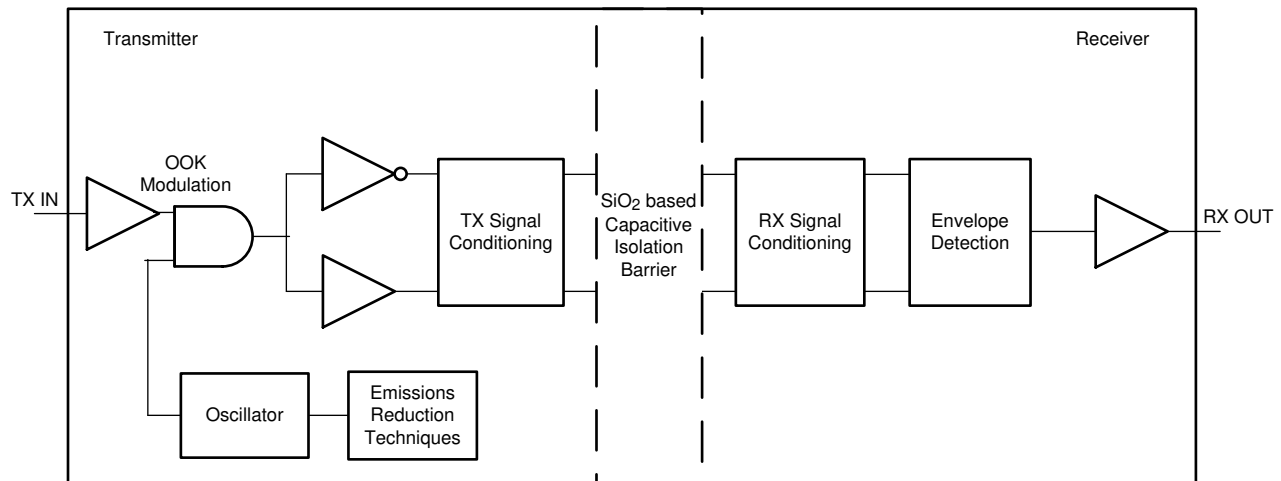

Figure 7-1. Conceptual Block Diagram of a Digital Capacitive Isolator

[Figure 7-2](#) shows a conceptual detail of how the OOK scheme works.

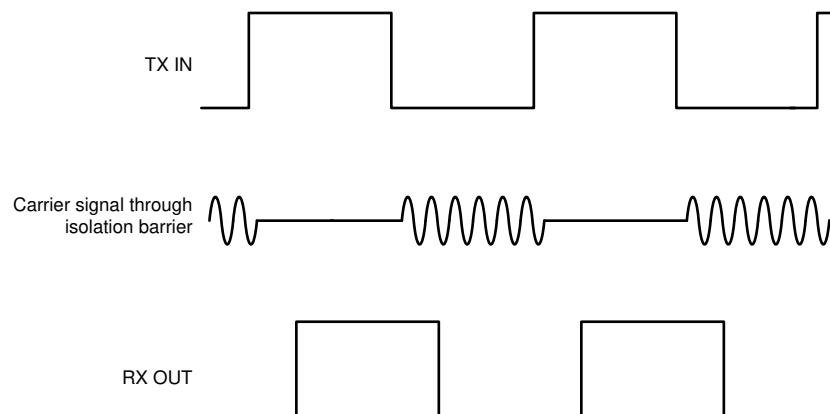

Figure 7-2. On-Off Keying (OOK) Based Modulation Scheme

7.3 Feature Description

The ISO7710 device is available in two default output state options to enable a variety of application uses. [Table 7-1](#) lists the device features.

Table 7-1. Device Features

PART NUMBER	MAXIMUM DATA RATE	CHANNEL DIRECTION	DEFAULT OUTPUT STATE	PACKAGE	RATED ISOLATION ⁽¹⁾
ISO7710	100 Mbps	1 Forward, 0 Reverse	High	DW-16	5000 V _{RMS} / 8000 V _{PK}
				D-8	3000 V _{RMS} / 4242 V _{PK}
ISO7710F	100 Mbps	1 Forward, 0 Reverse	Low	DW-16	5000 V _{RMS} / 8000 V _{PK}
				D-8	3000 V _{RMS} / 4242 V _{PK}

(1) See the [Safety-Related Certifications](#) section for detailed isolation ratings.

7.3.1 Electromagnetic Compatibility (EMC) Considerations

Many applications in harsh industrial environment are sensitive to disturbances such as electrostatic discharge (ESD), electrical fast transient (EFT), surge and electromagnetic emissions. These electromagnetic disturbances are regulated by international standards such as IEC 61000-4-x and CISPR 22. Although system-level performance and reliability depends, to a large extent, on the application board design and layout, the ISO7710 device incorporates many chip-level design improvements for overall system robustness. Some of these improvements include:

- Robust ESD protection cells for input and output signal pins and inter-chip bond pads.
- Low-resistance connectivity of ESD cells to supply and ground pins.
- Enhanced performance of high voltage isolation capacitor for better tolerance of ESD, EFT and surge events.
- Bigger on-chip decoupling capacitors to bypass undesirable high energy signals through a low impedance path.
- PMOS and NMOS devices isolated from each other by using guard rings to avoid triggering of parasitic SCRs.
- Reduced common mode currents across the isolation barrier by providing purely differential internal operation.

7.4 Device Functional Modes

Table 7-2 lists the functional modes of ISO7710 device.

Table 7-2. Function Table

V _{CC1} ⁽¹⁾	V _{CC2}	INPUT (IN) ⁽³⁾	OUTPUT (OUT)	COMMENTS
PU	PU	H	H	Normal Operation: A channel output assumes the logic state of the input.
		L	L	
		Open	Default	Default mode: When IN is open, the corresponding channel output goes to the default logic state. Default is <i>High</i> for ISO7710 and <i>Low</i> for ISO7710F.
PD	PU	X	Default	Default mode: When V _{CC1} is unpowered, a channel output assumes the logic state based on the selected default option. Default is <i>High</i> for ISO7710 and <i>Low</i> for ISO7710F. When V _{CC1} transitions from unpowered to powered-up, a channel output assumes the logic state of the input. When V _{CC1} transitions from powered-up to unpowered, channel output assumes the selected default state.
X	PD	X	Undetermined	When V _{CC2} is unpowered, a channel output is undetermined ⁽²⁾ . When V _{CC2} transitions from unpowered to powered-up, a channel output assumes the logic state of the input

(1) PU = Powered up (V_{CC} ≥ 2.25 V); PD = Powered down (V_{CC} ≤ 1.7 V); X = Irrelevant; H = High level; L = Low level

(2) The outputs are in undetermined state when 1.7 V < V_{CC1}, V_{CC2} < 2.25 V.

(3) A strongly driven input signal can weakly power the floating V_{CC} via an internal protection diode and cause undetermined output.

7.4.1 Device I/O Schematics

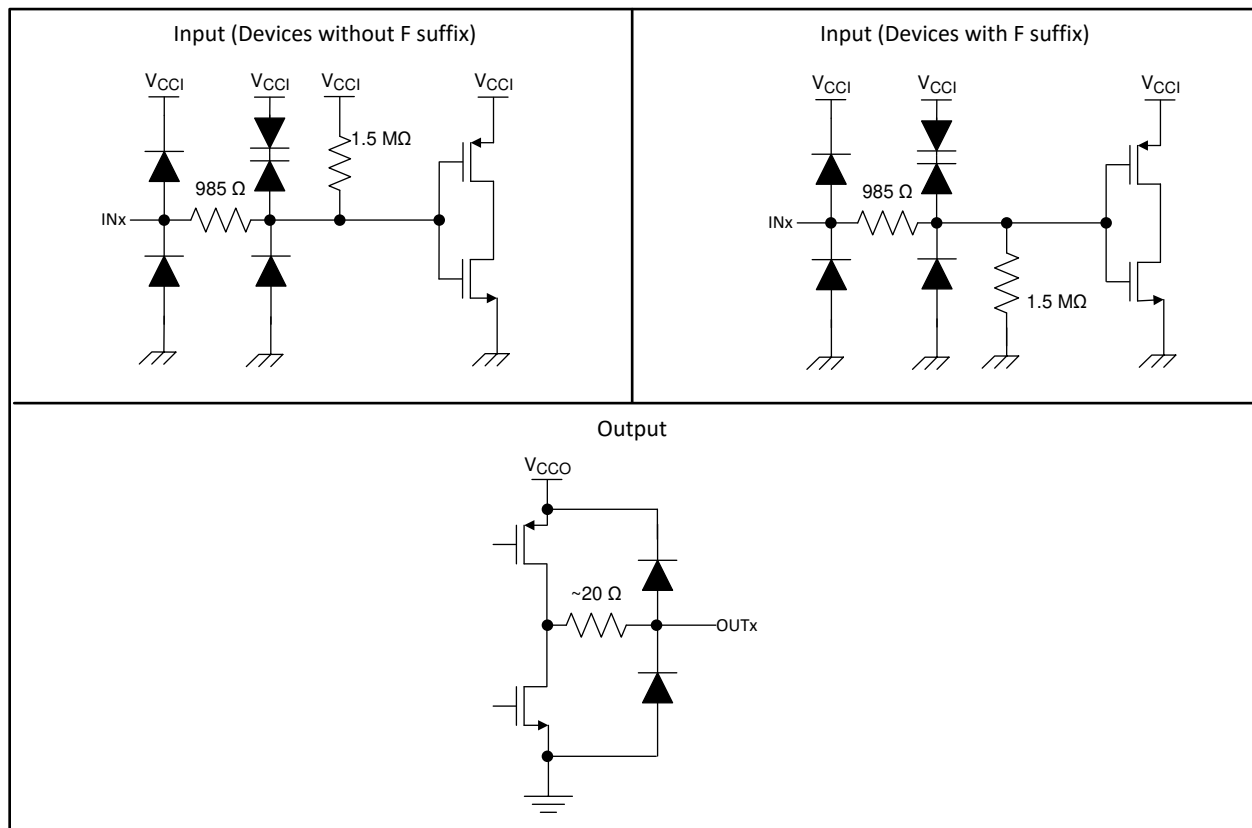

Copyright © 2016, Texas Instruments Incorporated

Figure 7-3. Device I/O Schematics

8 Application and Implementation

Note

Information in the following applications sections is not part of the TI component specification, and TI does not warrant its accuracy or completeness. TI's customers are responsible for determining suitability of components for their purposes. Customers should validate and test their design implementation to confirm system functionality.

8.1 Application Information

The ISO7710 device is a high-performance, single-channel digital isolator. The device uses single-ended CMOS-logic switching technology. The supply voltage range is from 2.25 V to 5.5 V for both supplies, V_{CC1} and V_{CC2} . When designing with digital isolators, keep in mind that because of the single-ended design structure, digital isolators do not conform to any specific interface standard and are only intended for isolating single-ended CMOS or TTL digital signal lines. The isolator is typically placed between the data controller (that is, μC or UART), and a data converter or a line transceiver, regardless of the interface type or standard.

8.2 Typical Application

The ISO7710 device can be used with Texas Instruments' mixed signal microcontroller, CAN transceiver, transformer driver, and low-dropout voltage regulator to create an Isolated CAN Interface as shown below.

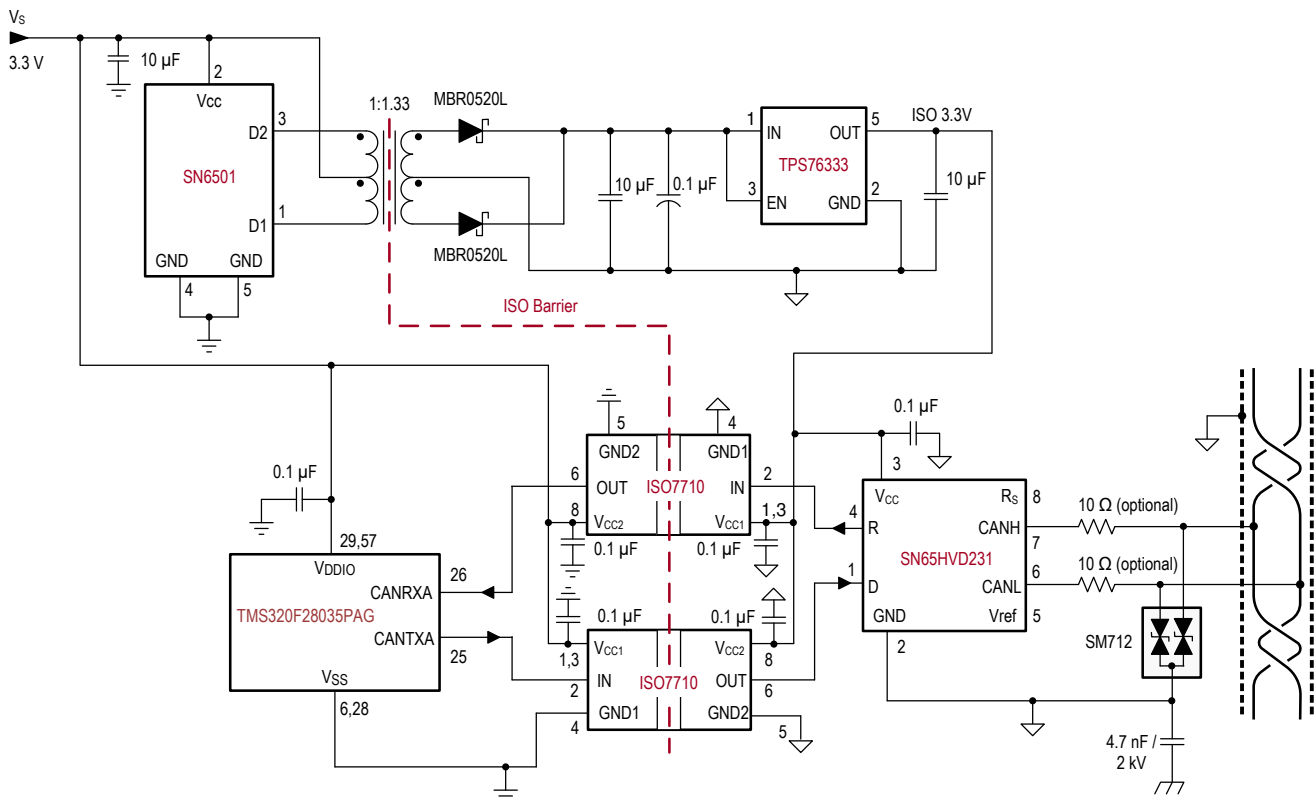

Copyright © 2016, Texas Instruments Incorporated

Figure 8-1. Isolated CAN Interface

8.2.1 Design Requirements

To design with this device, use the parameters listed in [Table 8-1](#).

Table 8-1. Design Parameters

PARAMETER	VALUE
Supply voltage, V_{CC1} and V_{CC2}	2.25 V to 5.5 V
Decoupling capacitor between V_{CC1} and GND1	0.1 μ F
Decoupling capacitor from V_{CC2} and GND2	0.1 μ F

8.2.2 Detailed Design Procedure

Unlike optocouplers, which require components to improve performance, provide bias, or limit current, the ISO7710 device only requires two external bypass capacitors to operate.

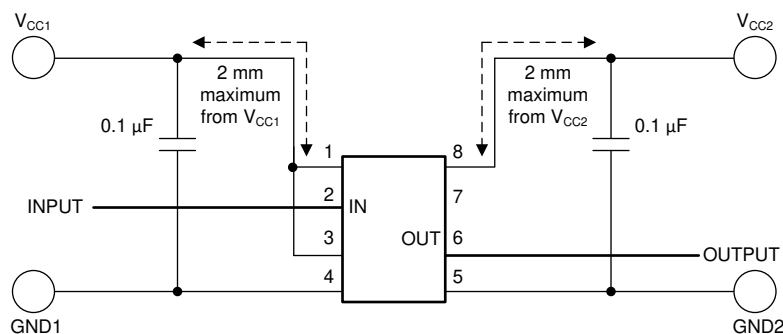

Figure 8-2. Typical ISO7710 Circuit Hook-up

8.2.3 Application Curve

The following typical eye diagram of the ISO7710 device indicates low jitter and wide open eye at the maximum data rate of 100 Mbps.

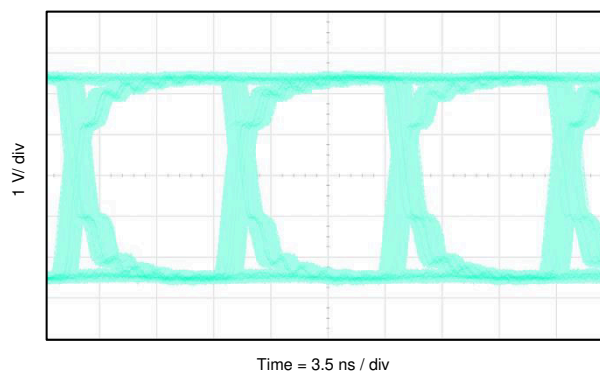

Figure 8-3. ISO7710 Eye Diagram at 100 Mbps PRBS, 5-V Supplies and 25°C

8.2.3.1 Insulation Lifetime

Insulation lifetime projection data is collected by using industry-standard Time Dependent Dielectric Breakdown (TDDB) test method. In this test, all pins on each side of the barrier are tied together creating a two-terminal device and high voltage applied between the two sides; See [Figure 8-4](#) for TDDB test setup. The insulation breakdown data is collected at various high voltages switching at 60 Hz over temperature. For reinforced insulation, VDE standard requires the use of TDDB projection line with failure rate of less than 1 part per million (ppm). Even though the expected minimum insulation lifetime is 20 years at the specified working isolation voltage, VDE reinforced certification requires additional safety margin of 20% for working voltage and 50% for lifetime which translates into minimum required insulation lifetime of 30 years at a working voltage that's 20% higher than the specified value.

[Figure 8-5](#) shows the intrinsic capability of the isolation barrier to withstand high voltage stress over the lifetime of the device. Based on the TDDB data, the intrinsic capability of the insulation is 1500 V_{RMS} with a lifetime of 36 years. Other factors, such as package size, pollution degree, material group, and more can further limit the working voltage of the component. The working voltage of DW-16 package is specified up to 1500 V_{RMS} and D-8 package up to 450 V_{RMS}. At the lower working voltages, the corresponding insulation lifetime is much longer than 36 years.

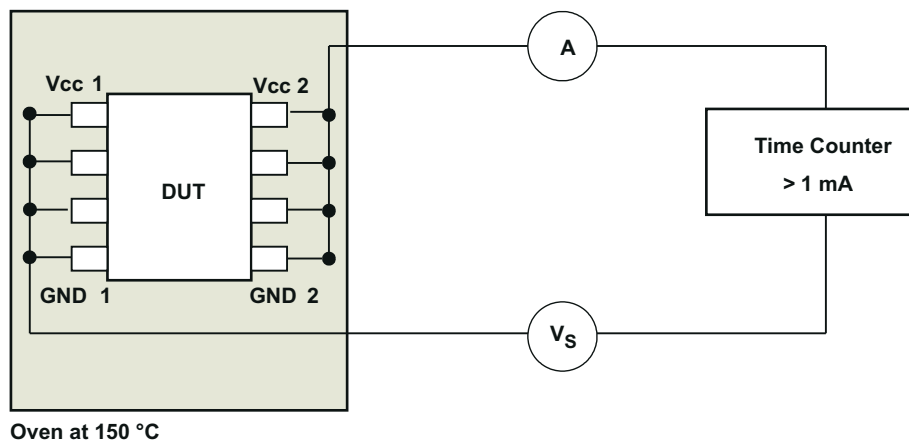

Figure 8-4. Test Setup for Insulation Lifetime Measurement

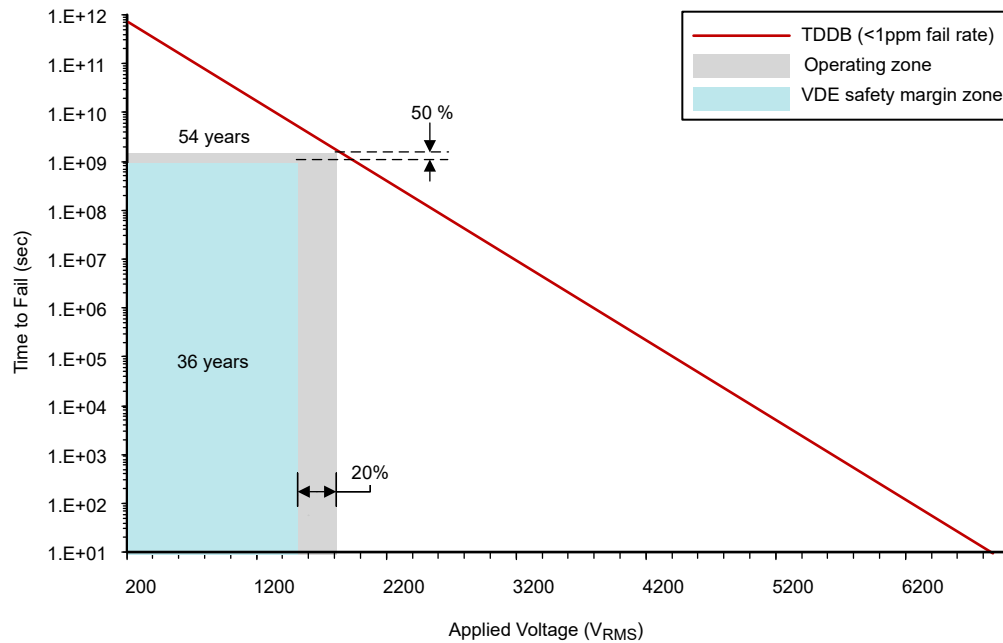

Figure 8-5. Insulation Lifetime Projection Data

8.3 Power Supply Recommendations

To help provide reliable operation at data rates and supply voltages, a 0.1- μF bypass capacitor is recommended at the input and output supply pins (V_{CC1} and V_{CC2}). The capacitors must be placed as close to the supply pins as possible. If only a single primary-side power supply is available in an application, isolated power can be generated for the secondary-side with the help of a transformer driver such as Texas Instruments' [SN6501](#) or [SN6505A](#). For such applications, detailed power supply design and transformer selection recommendations are available in [SN6501 Transformer Driver for Isolated Power Supplies](#) or [SN6505 Low-Noise 1-A Transformer Drivers for Isolated Power Supplies](#).

8.4 Layout

8.4.1 Layout Guidelines

A minimum of four layers is required to accomplish a low EMI PCB design (see [Figure 8-6](#)). Layer stacking must be in the following order (top-to-bottom): high-speed signal layer, ground plane, power plane and low-frequency signal layer.

- Routing the high-speed traces on the top layer avoids the use of vias (and the introduction of their inductances) and allows for clean interconnects between the isolator and the transmitter and receiver circuits of the data link.
- Placing a solid ground plane next to the high-speed signal layer establishes controlled impedance for transmission line interconnects and provides an excellent low-inductance path for the return current flow.
- Placing the power plane next to the ground plane creates additional high-frequency bypass capacitance of approximately 100 pF/in².
- Routing the slower speed control signals on the bottom layer allows for greater flexibility as these signal links usually have margin to tolerate discontinuities such as vias.

If an additional supply voltage plane or signal layer is needed, add a second power or ground plane system to the stack to keep the planes symmetrical. This makes the stack mechanically stable and prevents warping. Also the power and ground plane of each power system can be placed closer together, thus increasing the high-frequency bypass capacitance significantly.

For detailed layout recommendations, refer to the [Digital Isolator Design Guide](#).

8.4.1.1 PCB Material

For digital circuit boards operating at less than 150 Mbps, (or rise and fall times greater than 1 ns), and trace lengths of up to 10 inches, use standard FR-4 UL94V-0 printed circuit board. This PCB is preferred over cheaper alternatives because of lower dielectric losses at high frequencies, less moisture absorption, greater strength and stiffness, and the self-extinguishing flammability-characteristics.

8.4.2 Layout Example

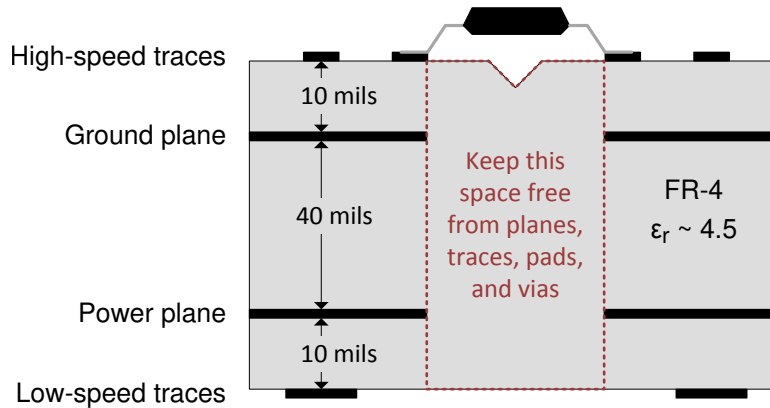

Figure 8-6. Layout Example

9 Device and Documentation Support

9.1 Documentation Support

9.1.1 Related Documentation

For related documentation, see the following:

- Texas Instruments, [Digital Isolator Design Guide](#), application note
- Texas Instruments, [Isolation Glossary](#), application note
- Texas Instruments, [How to use isolation to improve ESD, EFT, and Surge immunity in industrial systems](#), analog design journal
- Texas Instruments, [SN6501 Transformer Driver for Isolated Power Supplies](#), data sheet
- Texas Instruments, [SN65HVD23x 3.3-V CAN Bus Transceivers](#), data sheet
- Texas Instruments, [TMS320F28035 Piccolo™ Microcontrollers](#), data sheet
- Texas Instruments, [TPS76333 Low-Power 150-mA Low-Dropout Linear Regulators](#), data sheet

9.2 Receiving Notification of Documentation Updates

To receive notification of documentation updates, navigate to the device product folder on ti.com. In the upper right corner, click on *Alert me* to register and receive a weekly digest of any product information that has changed. For change details, review the revision history included in any revised document.

9.3 Support Resources

[TI E2E™ support forums](#) are an engineer's go-to source for fast, verified answers and design help — straight from the experts. Search existing answers or ask your own question to get the quick design help you need.

Linked content is provided "AS IS" by the respective contributors. They do not constitute TI specifications and do not necessarily reflect TI's views; see TI's [Terms of Use](#).

9.4 Trademarks

Piccolo™ is a trademark of Texas Instruments.

TI E2E™ is a trademark of Texas Instruments.

All trademarks are the property of their respective owners.

9.5 Electrostatic Discharge Caution



This integrated circuit can be damaged by ESD. Texas Instruments recommends that all integrated circuits be handled with appropriate precautions. Failure to observe proper handling and installation procedures can cause damage.

ESD damage can range from subtle performance degradation to complete device failure. Precision integrated circuits may be more susceptible to damage because very small parametric changes could cause the device not to meet its published specifications.

9.6 Glossary

[TI Glossary](#) This glossary lists and explains terms, acronyms, and definitions.

10 Revision History

NOTE: Page numbers for previous revisions may differ from page numbers in the current version.

Changes from Revision D (March 2023) to Revision E (December 2024)	Page
• Updated the number formatting for tables, figures, and cross-references throughout the document.....	1
• Updated maximum power dissipation in the power ratings section.....	7
• Updated distance through isolation, while maintaining other insulation specifications.....	8
• Updated maximum total current consumption values throughout the supply current characteristics sections.	11
• Updated maximum propagation delay specifications throughout the switching characteristics sections.....	14
• Updated TDDDB plot and the projected lifetime.....	23

Changes from Revision C (April 2020) to Revision D (March 2023)	Page
• Changed standard name from: "DIN V VDE V 0884-11:2017-01" to: "DIN EN IEC 60747-17 (VDE 0884-17)" throughout the document.....	1
• Removed references to standard IEC/EN/CSA 60950-1 throughout the document.....	1
• Removed standard revision and year references from all standard names throughout the document	1
• Added Maximum impulse voltage (V_{IMP}) specification per DIN EN IEC 60747-17 (VDE 0884-17).....	8
• Changed test conditions and values of Maximum surge isolation voltage (V_{IOSM}) specification per DIN EN IEC 60747-17 (VDE 0884-17).....	8
• Clarified method b test conditions of Apparent charge (q_{PD}).....	8
• Changed working voltage lifetime margin from: 87.5% to: 50%, minimum required insulation lifetime from: 37.5 years to: 30 years and insulation lifetime per TDDb from: 135 years to: 169 years in per DIN EN IEC 60747-17 (VDE 0884-17).....	23
• Changed Figure 8-5 per DIN EN IEC 60747-17 (VDE 0884-17).....	23

Changes from Revision B (March 2017) to Revision C (April 2020)	Page
• Made editorial and cosmetic changes throughout the document	1
• Changed From: "Isolation Barrier Life: >40 Years" To: ">100-year projected lifetime at 1500 V_{RMS} working voltage" in Section 1	1
• Added "Up to 5000 V_{RMS} isolation rating" in Section 1	1
• Added "Up to 12.8 kV surge capability" in Section 1	1
• Added "±8 kV IEC 61000-4-2 contact discharge protection across isolation barrier" in Section 1	1
• Added "Automotive version available: <i>ISO7710-Q1</i> " in Section 1	1
• Changed From: "VDE Reinforced Insulation per DIN V VDE V 0884-10 (VDE V 0884-10):2006-12" To: "VDE reinforced insulation per DIN VDE V 0884-11:2017-01" in Section 1	1
• Combined CSA, CQC, and TUV bullets into a single bullet with standard names in Section 1	1
• Deleted "VDE, UL, CSA, and TUV Certifications for DW-16 package complete; all other certifications planned" bullet in Section 1	1
• Updated Simplified Schematic to show two isolation capacitors in series instead of a single isolation capacitor.....	1
• Added "Contact discharge per IEC 61000-4-2" specification of 8000V	5
• Changed "Signaling rate" to "Data rate" and added table note.....	6
• Updated DW-16 package V_{IORM} and V_{IOWM} values.....	8
• Added TDDb figure reference to V_{IOWM}	8
• Updated V_{IOSM} , V_{IOTM} , q_{pd} test conditions.....	8
• Corrected ground symbols for "Input (Devices with F suffix)" in Section 7.4.1	20
• Fixed Figure 8-2 INPUT wire connection.....	22
• Added Section 8.2.3.1 sub-section under Section 8.2.3 section.....	23
• Added ' <i>How to use isolation to improve ESD, EFT, and Surge immunity in industrial systems</i> ' to Section 9.1 section.....	26

Changes from Revision A (December 2016) to Revision B (March 2017)	Page
• Added D-8 values for TUV.....	9
• Changed the <i>Electrostatic Discharge Caution</i> statement	26

Changes from Revision * (November 2016) to Revision A (December 2016)	Page
• Changed <i>Feature</i> From: IEC 60950-1, IEC 60601-1 and IEC 61010-1 End Equipment Standards To: IEC 60950-1 and IEC 60601-1 End Equipment Standards.....	1
• Added Climatic category.....	8
• Updated CSA column and changed DW package to (DW-16).....	9

- Changed t_{ie} TYP value from 1.5 to 1 in Switching Characteristics tables throughout the document..... [14](#)
-

11 Mechanical, Packaging, and Orderable Information

The following pages include mechanical, packaging, and orderable information. This information is the most current data available for the designated devices. This data is subject to change without notice and revision of this document. For browser-based versions of this data sheet, refer to the left-hand navigation.



D0008B

PACKAGE OUTLINE
SOIC - 1.75 mm max height

SMALL OUTLINE INTEGRATED CIRCUIT

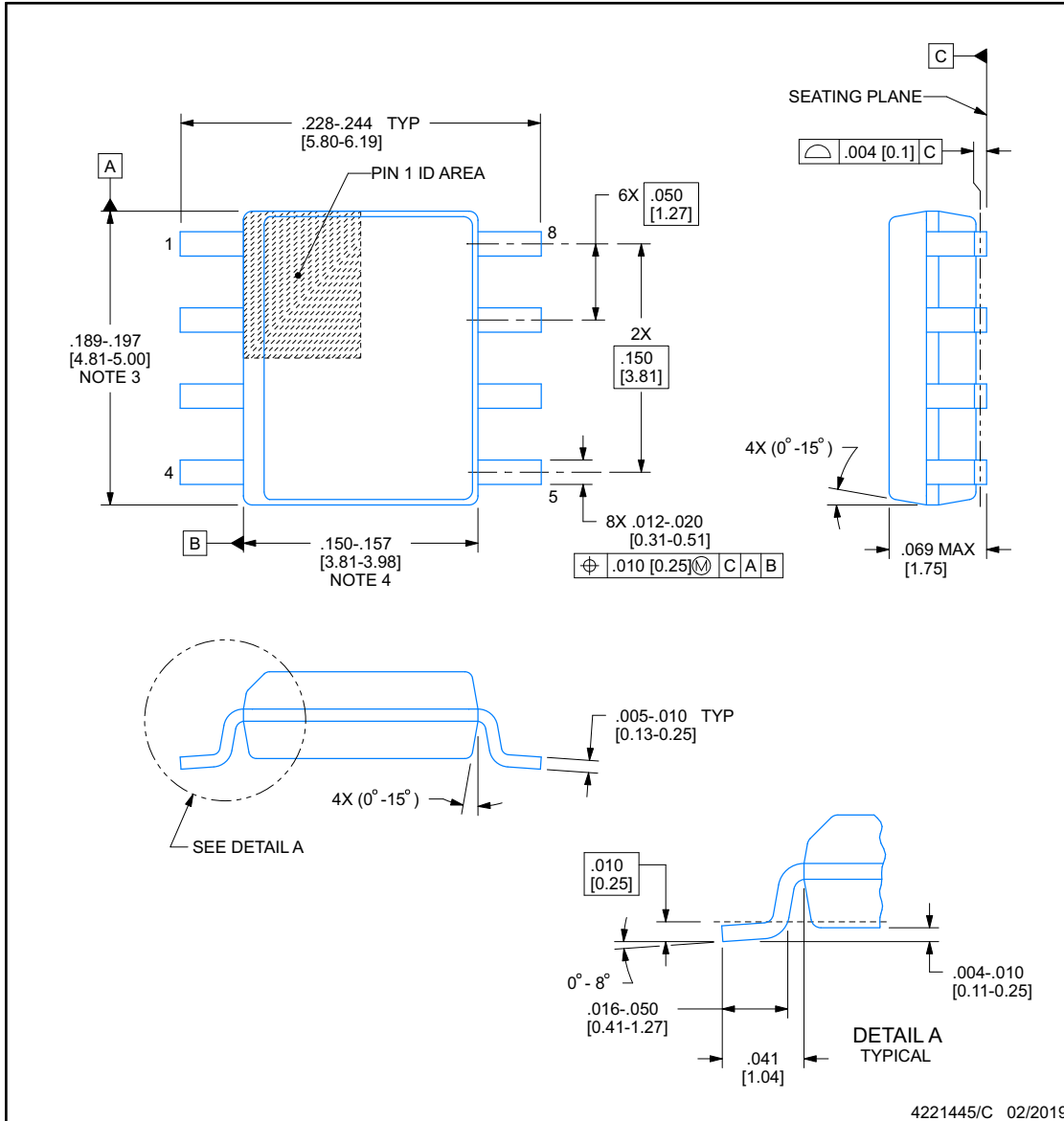

NOTES:

1. Linear dimensions are in inches [millimeters]. Dimensions in parenthesis are for reference only. Controlling dimensions are in inches. Dimensioning and tolerancing per ASME Y14.5M.
2. This drawing is subject to change without notice.
3. This dimension does not include mold flash, protrusions, or gate burrs. Mold flash, protrusions, or gate burrs shall not exceed $.006$ [0.15], per side.
4. This dimension does not include interlead flash.
5. Reference JEDEC registration MS-012, variation AA.

EXAMPLE BOARD LAYOUT

D0008B

SOIC - 1.75 mm max height

SMALL OUTLINE INTEGRATED CIRCUIT

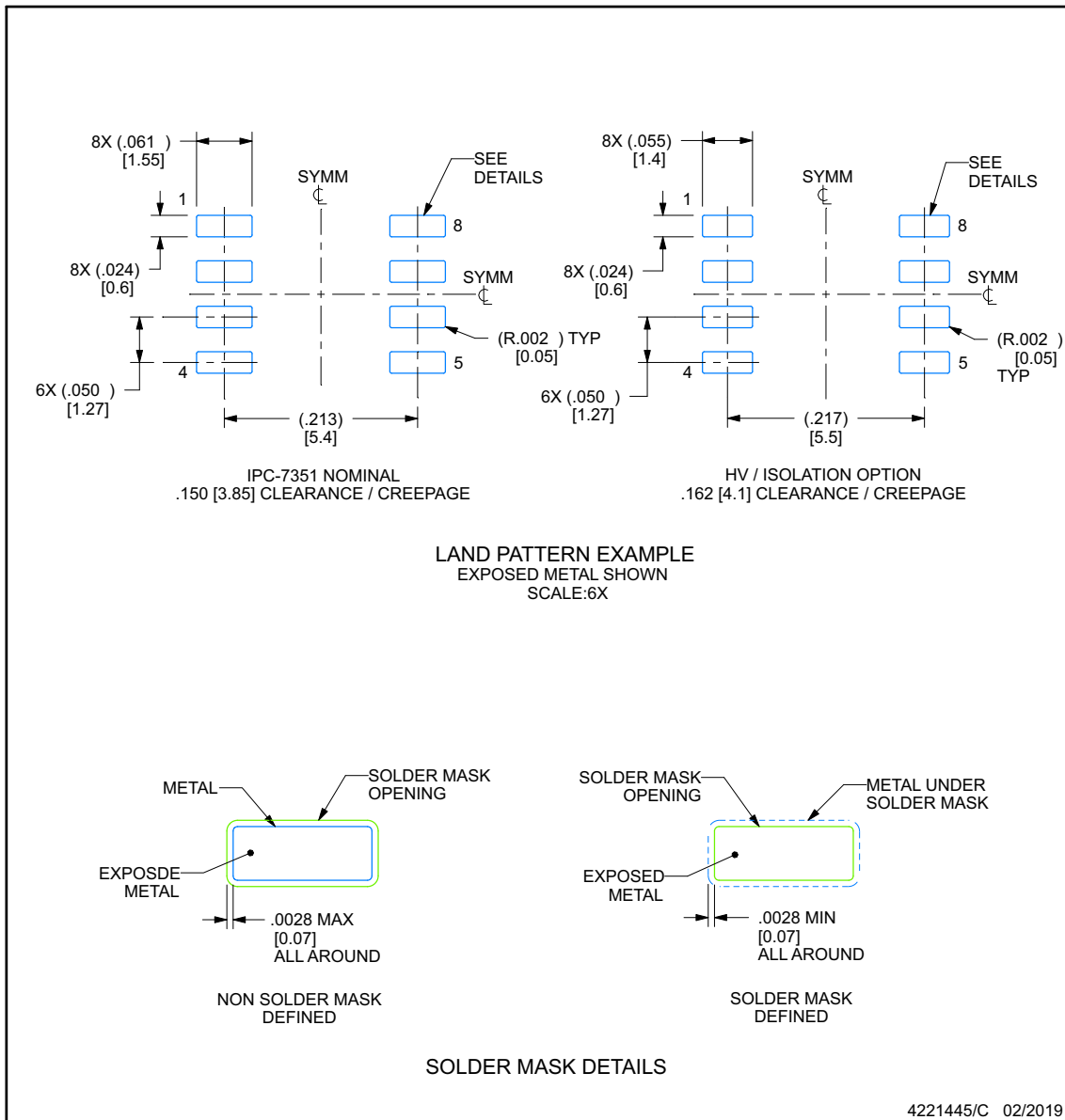

NOTES: (continued)

- 6. Publication IPC-7351 may have alternate designs.
- 7. Solder mask tolerances between and around signal pads can vary based on board fabrication site.

EXAMPLE STENCIL DESIGN

D0008B

SOIC - 1.75 mm max height

SMALL OUTLINE INTEGRATED CIRCUIT

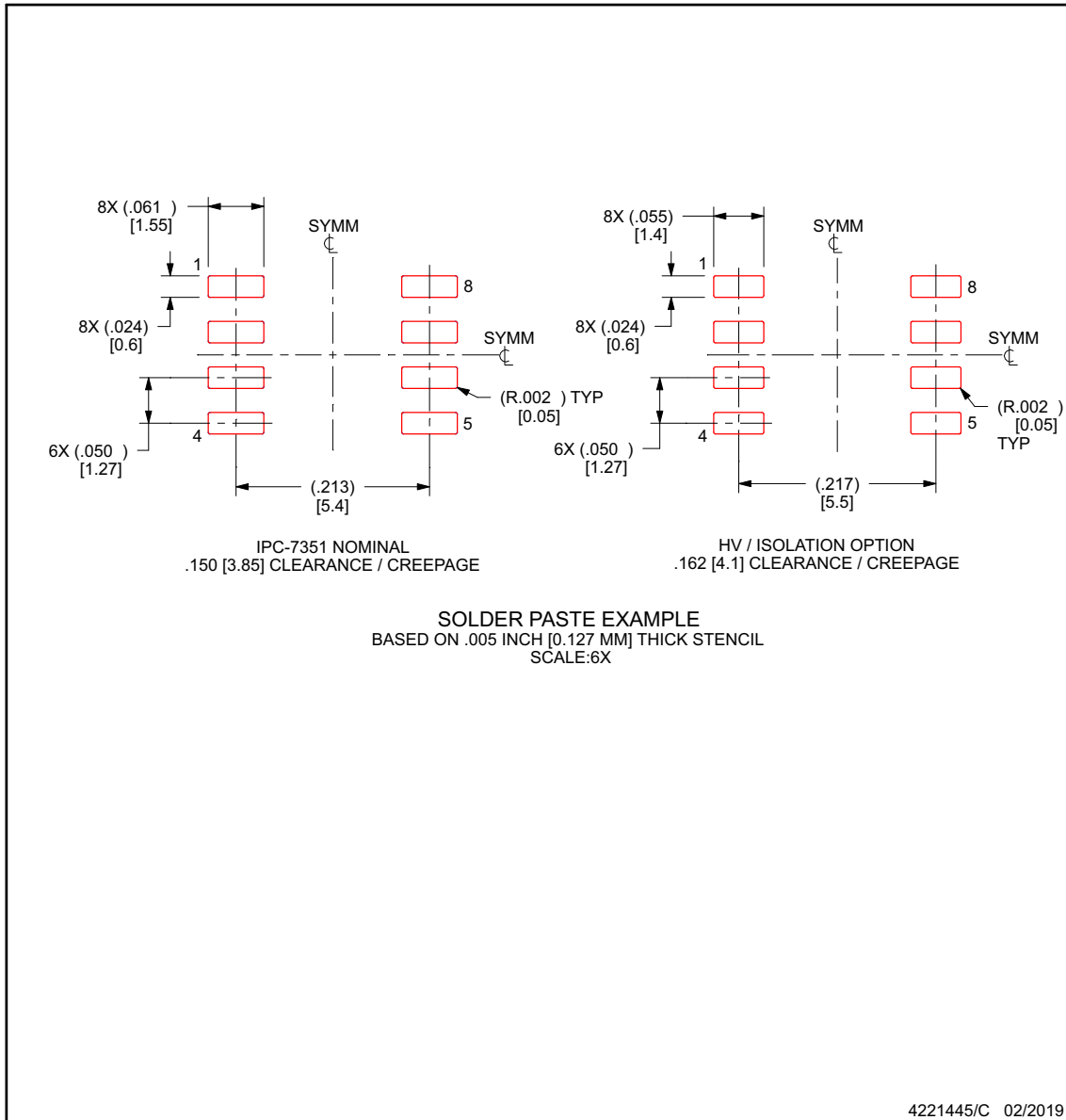

NOTES: (continued)

- 8. Laser cutting apertures with trapezoidal walls and rounded corners may offer better paste release. IPC-7525 may have alternate design recommendations.
- 9. Board assembly site may have different recommendations for stencil design.

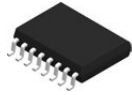

DW0016B

PACKAGE OUTLINE
SOIC - 2.65 mm max height

SOIC

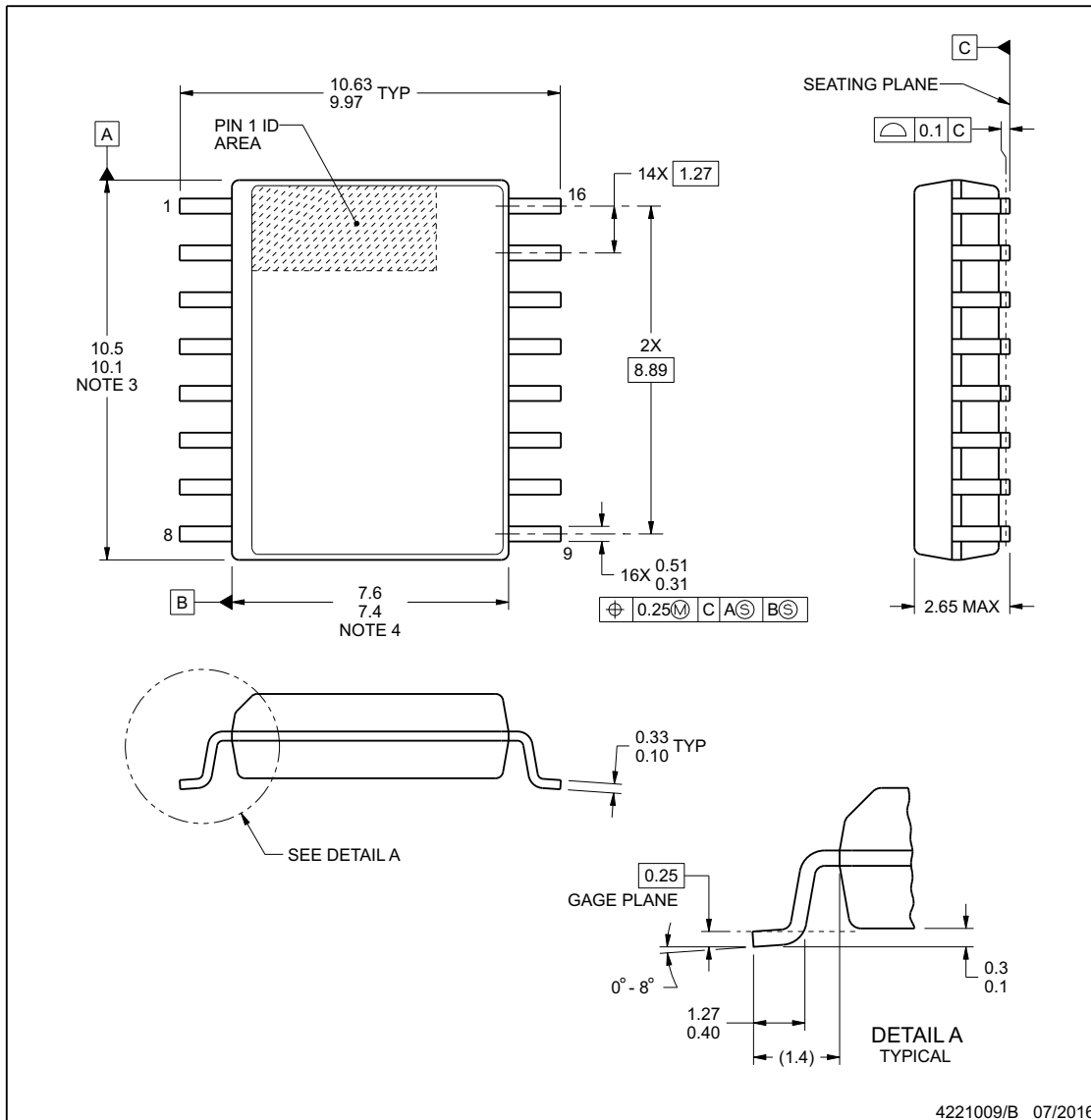

4221009/B 07/2016

NOTES:

1. All linear dimensions are in millimeters. Dimensions in parenthesis are for reference only. Dimensioning and tolerancing per ASME Y14.5M.
2. This drawing is subject to change without notice.
3. This dimension does not include mold flash, protrusions, or gate burrs. Mold flash, protrusions, or gate burrs shall not exceed 0.15 mm, per side.
4. This dimension does not include interlead flash. Interlead flash shall not exceed 0.25 mm, per side.
5. Reference JEDEC registration MS-013.

EXAMPLE BOARD LAYOUT

DW0016B

SOIC - 2.65 mm max height

SOIC

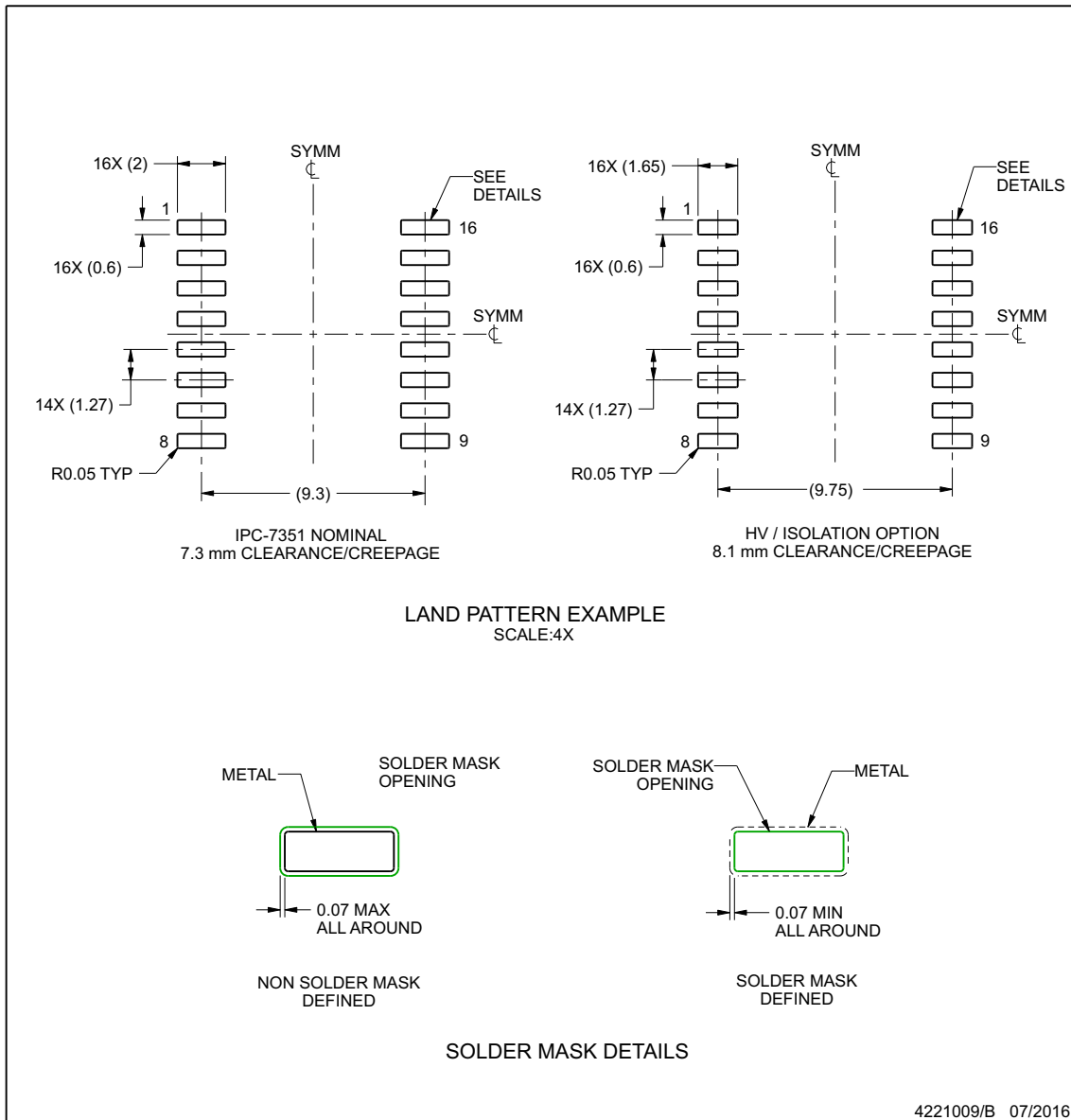

NOTES: (continued)

- 6. Publication IPC-7351 may have alternate designs.
- 7. Solder mask tolerances between and around signal pads can vary based on board fabrication site.

www.ti.com

EXAMPLE STENCIL DESIGN

DW0016B

SOIC - 2.65 mm max height

SOIC

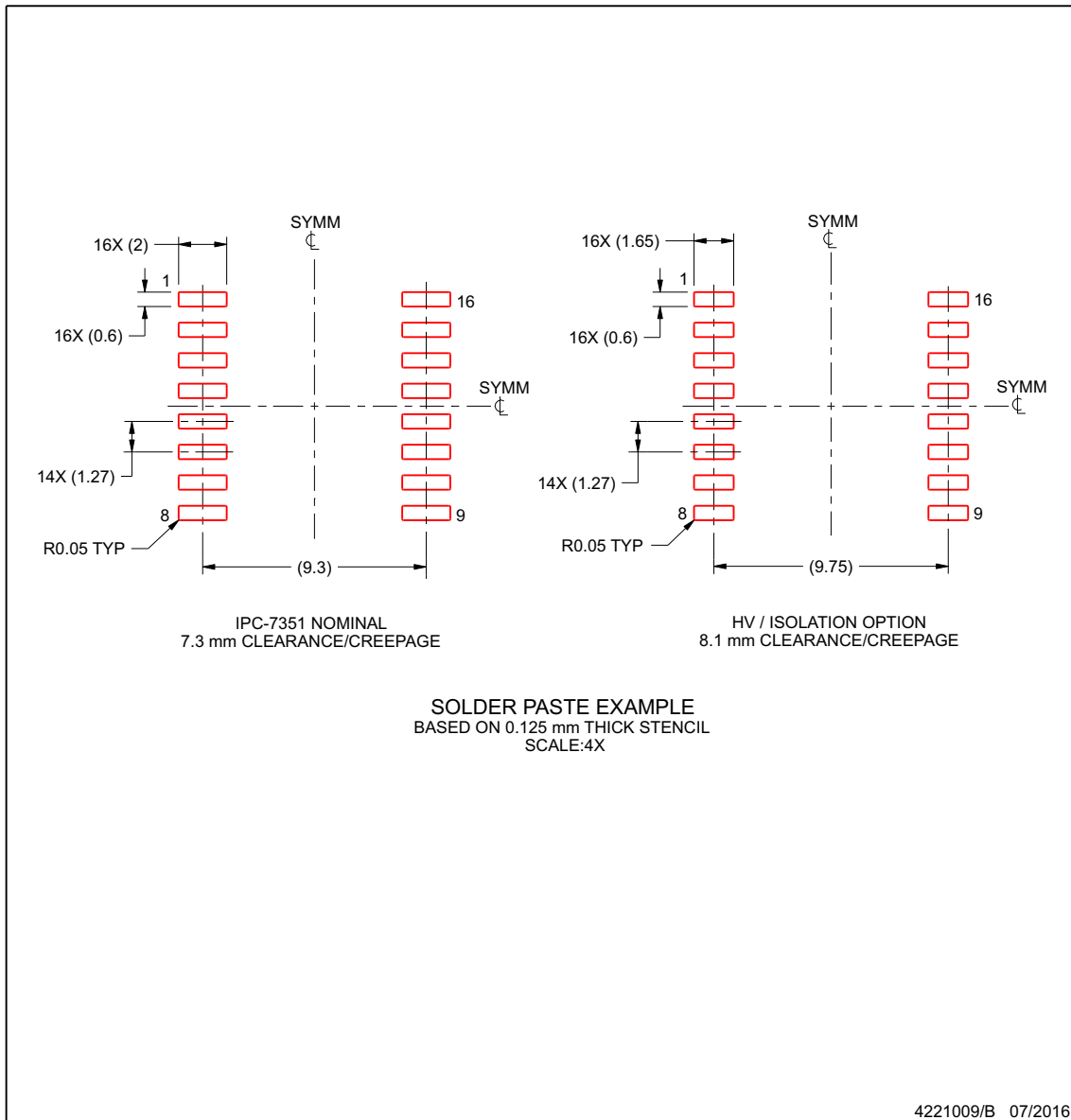

NOTES: (continued)

- 8. Laser cutting apertures with trapezoidal walls and rounded corners may offer better paste release. IPC-7525 may have alternate design recommendations.
- 9. Board assembly site may have different recommendations for stencil design.

www.ti.com

PACKAGING INFORMATION

Orderable part number	Status (1)	Material type (2)	Package Pins	Package qty Carrier	RoHS (3)	Lead finish/ Ball material (4)	MSL rating/ Peak reflow (5)	Op temp (°C)	Part marking (6)
ISO7710DR	Active	Production	SOIC (D) 8	2500 LARGE T&R	Yes	NIPDAU	Level-2-260C-1 YEAR	-55 to 125	7710
ISO7710DR.A	Active	Production	SOIC (D) 8	2500 LARGE T&R	Yes	NIPDAU	Level-2-260C-1 YEAR	-55 to 125	7710
ISO7710DWR	Active	Production	SOIC (DW) 16	2000 LARGE T&R	Yes	NIPDAU	Level-2-260C-1 YEAR	-55 to 125	ISO7710
ISO7710DWR.A	Active	Production	SOIC (DW) 16	2000 LARGE T&R	Yes	NIPDAU	Level-2-260C-1 YEAR	-55 to 125	ISO7710
ISO7710DWRG4	Active	Production	SOIC (DW) 16	2000 LARGE T&R	Yes	NIPDAU	Level-2-260C-1 YEAR	-55 to 125	ISO7710
ISO7710DWRG4.A	Active	Production	SOIC (DW) 16	2000 LARGE T&R	Yes	NIPDAU	Level-2-260C-1 YEAR	-55 to 125	ISO7710
ISO7710FDR	Active	Production	SOIC (D) 8	2500 LARGE T&R	Yes	NIPDAU	Level-2-260C-1 YEAR	-55 to 125	7710F
ISO7710FDR.A	Active	Production	SOIC (D) 8	2500 LARGE T&R	Yes	NIPDAU	Level-2-260C-1 YEAR	-55 to 125	7710F
ISO7710FDWR	Active	Production	SOIC (DW) 16	2000 LARGE T&R	Yes	NIPDAU	Level-2-260C-1 YEAR	-55 to 125	ISO7710F
ISO7710FDWR.A	Active	Production	SOIC (DW) 16	2000 LARGE T&R	Yes	NIPDAU	Level-2-260C-1 YEAR	-55 to 125	ISO7710F

(1) **Status:** For more details on status, see our [product life cycle](#).

(2) **Material type:** When designated, preproduction parts are prototypes/experimental devices, and are not yet approved or released for full production. Testing and final process, including without limitation quality assurance, reliability performance testing, and/or process qualification, may not yet be complete, and this item is subject to further changes or possible discontinuation. If available for ordering, purchases will be subject to an additional waiver at checkout, and are intended for early internal evaluation purposes only. These items are sold without warranties of any kind.

(3) **RoHS values:** Yes, No, RoHS Exempt. See the [TI RoHS Statement](#) for additional information and value definition.

(4) **Lead finish/Ball material:** Parts may have multiple material finish options. Finish options are separated by a vertical ruled line. Lead finish/Ball material values may wrap to two lines if the finish value exceeds the maximum column width.

(5) **MSL rating/Peak reflow:** The moisture sensitivity level ratings and peak solder (reflow) temperatures. In the event that a part has multiple moisture sensitivity ratings, only the lowest level per JEDEC standards is shown. Refer to the shipping label for the actual reflow temperature that will be used to mount the part to the printed circuit board.

(6) **Part marking:** There may be an additional marking, which relates to the logo, the lot trace code information, or the environmental category of the part.

Multiple part markings will be inside parentheses. Only one part marking contained in parentheses and separated by a "~" will appear on a part. If a line is indented then it is a continuation of the previous line and the two combined represent the entire part marking for that device.

Important Information and Disclaimer: The information provided on this page represents TI's knowledge and belief as of the date that it is provided. TI bases its knowledge and belief on information provided by third parties, and makes no representation or warranty as to the accuracy of such information. Efforts are underway to better integrate information from third parties. TI has taken and continues to take reasonable steps to provide representative

and accurate information but may not have conducted destructive testing or chemical analysis on incoming materials and chemicals. TI and TI suppliers consider certain information to be proprietary, and thus CAS numbers and other limited information may not be available for release.

In no event shall TI's liability arising out of such information exceed the total purchase price of the TI part(s) at issue in this document sold by TI to Customer on an annual basis.

OTHER QUALIFIED VERSIONS OF ISO7710 :

- Automotive : [ISO7710-Q1](#)

NOTE: Qualified Version Definitions:

- Automotive - Q100 devices qualified for high-reliability automotive applications targeting zero defects

TAPE AND REEL INFORMATION

QUADRANT ASSIGNMENTS FOR PIN 1 ORIENTATION IN TAPE

*All dimensions are nominal

Device	Package Type	Package Drawing	Pins	SPQ	Reel Diameter (mm)	Reel Width W1 (mm)	A0 (mm)	B0 (mm)	K0 (mm)	P1 (mm)	W (mm)	Pin1 Quadrant
ISO7710DR	SOIC	D	8	2500	330.0	12.4	6.4	5.2	2.1	8.0	12.0	Q1
ISO7710DWR	SOIC	DW	16	2000	330.0	16.4	10.75	10.7	2.7	12.0	16.0	Q1
ISO7710DWRG4	SOIC	DW	16	2000	330.0	16.4	10.75	10.7	2.7	12.0	16.0	Q1
ISO7710FDR	SOIC	D	8	2500	330.0	12.4	6.4	5.2	2.1	8.0	12.0	Q1
ISO7710FDWR	SOIC	DW	16	2000	330.0	16.4	10.75	10.7	2.7	12.0	16.0	Q1

TAPE AND REEL BOX DIMENSIONS

*All dimensions are nominal

Device	Package Type	Package Drawing	Pins	SPQ	Length (mm)	Width (mm)	Height (mm)
ISO7710DR	SOIC	D	8	2500	353.0	353.0	32.0
ISO7710DWR	SOIC	DW	16	2000	353.0	353.0	32.0
ISO7710DWRG4	SOIC	DW	16	2000	353.0	353.0	32.0
ISO7710FDR	SOIC	D	8	2500	353.0	353.0	32.0
ISO7710FDWR	SOIC	DW	16	2000	353.0	353.0	32.0

IMPORTANT NOTICE AND DISCLAIMER

TI PROVIDES TECHNICAL AND RELIABILITY DATA (INCLUDING DATASHEETS), DESIGN RESOURCES (INCLUDING REFERENCE DESIGNS), APPLICATION OR OTHER DESIGN ADVICE, WEB TOOLS, SAFETY INFORMATION, AND OTHER RESOURCES "AS IS" AND WITH ALL FAULTS, AND DISCLAIMS ALL WARRANTIES, EXPRESS AND IMPLIED, INCLUDING WITHOUT LIMITATION ANY IMPLIED WARRANTIES OF MERCHANTABILITY, FITNESS FOR A PARTICULAR PURPOSE OR NON-INFRINGEMENT OF THIRD PARTY INTELLECTUAL PROPERTY RIGHTS.

These resources are intended for skilled developers designing with TI products. You are solely responsible for (1) selecting the appropriate TI products for your application, (2) designing, validating and testing your application, and (3) ensuring your application meets applicable standards, and any other safety, security, regulatory or other requirements.

These resources are subject to change without notice. TI grants you permission to use these resources only for development of an application that uses the TI products described in the resource. Other reproduction and display of these resources is prohibited. No license is granted to any other TI intellectual property right or to any third party intellectual property right. TI disclaims responsibility for, and you fully indemnify TI and its representatives against any claims, damages, costs, losses, and liabilities arising out of your use of these resources.

TI's products are provided subject to [TI's Terms of Sale](#), [TI's General Quality Guidelines](#), or other applicable terms available either on ti.com or provided in conjunction with such TI products. TI's provision of these resources does not expand or otherwise alter TI's applicable warranties or warranty disclaimers for TI products. Unless TI explicitly designates a product as custom or customer-specified, TI products are standard, catalog, general purpose devices.

TI objects to and rejects any additional or different terms you may propose.

Copyright © 2026, Texas Instruments Incorporated

Last updated 10/2025