

SN54LS592, SN54LS593, SN74LS592, SN74LS593 8-BIT BINARY COUNTERS WITH INPUT REGISTERS

SDLS004

D2633, JANUARY 1981 — REVISED MARCH 1988

- Parallel Register Inputs ('LS592)
- Parallel 3-State I/O: Register Inputs/Counter Outputs ('LS593)
- Counter has Direct Overriding Load and Clear
- Accurate Counter Frequency: DC to 20 MHz

description

The 'LS592 comes in a 16-pin package and consists of a parallel input, 8-bit storage register feeding an 8-bit binary counter. Both the register and the counter have individual positive-edge-triggered clocks. In addition, the counter has direct load and clear functions. A low-going \overline{RCO} pulse will be obtained when the counter reaches the hex word FF. Expansion is easily accomplished for two stages by connecting \overline{RCO} of the first stage to \overline{CCKEN} of the second stage. Cascading for larger count chains can be accomplished by connecting \overline{RCO} of each stage to CCK of the following stage.

The 'LS593 comes in a 20-pin package and has all the features of the 'LS592 plus 3-state I/O, which provides parallel counter outputs. The tables below show the operation of the enable (CCKEN, \overline{CCKEN}) inputs. A register clock enable (RCKEN) is also provided.

OUTPUT ENABLE CONTROL ('593 ONLY)

G	\overline{G}	A/Q _A thru H/Q _H
L	L	input mode
L	H	input mode
H	L	output mode
H	H	input mode

COUNTER CLOCK ENABLE CONTROL

CCKEN	\overline{CCKEN}	EFFECT ON CCK
L	L	Enable
L	H	Disable
H	L	Enable
H	H	Enable

SN54LS592 . . . J OR W PACKAGE SN74LS592 . . . N PACKAGE (TOP VIEW)

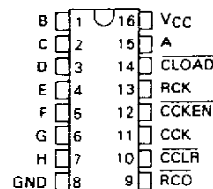

SN54LS592 . . . FK PACKAGE (TOP VIEW)

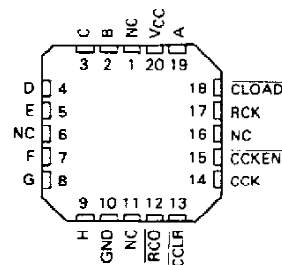

NC — No internal connection

SN54LS593 . . . J OR W PACKAGE SN74LS593 . . . DW OR N PACKAGE (TOP VIEW)

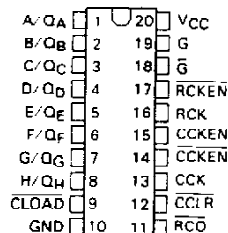

SN54LS593 . . . FK PACKAGE (TOP VIEW)

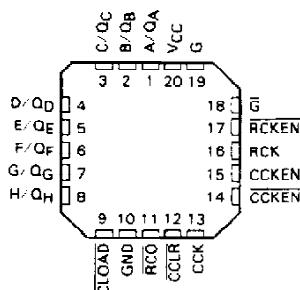

PRODUCTION DATA documents contain information current as of publication date. Products conform to specifications per the terms of Texas Instruments standard warranty. Production processing does not necessarily include testing of all parameters.

TEXAS
INSTRUMENTS

POST OFFICE BOX 655012 • DALLAS, TEXAS 75265

SN54LS592, SN54LS593, SN74LS592, SN74LS593 8-BIT BINARY COUNTERS WITH INPUT REGISTERS

schematics of inputs and outputs

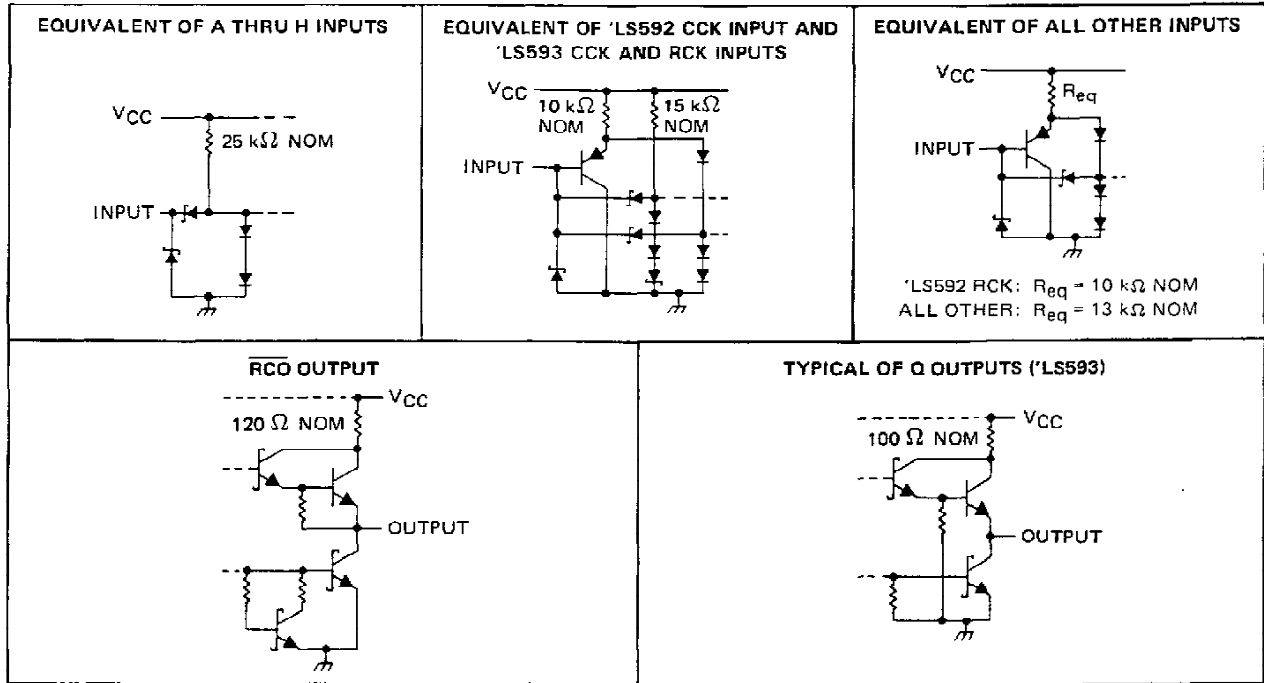

logic symbols†

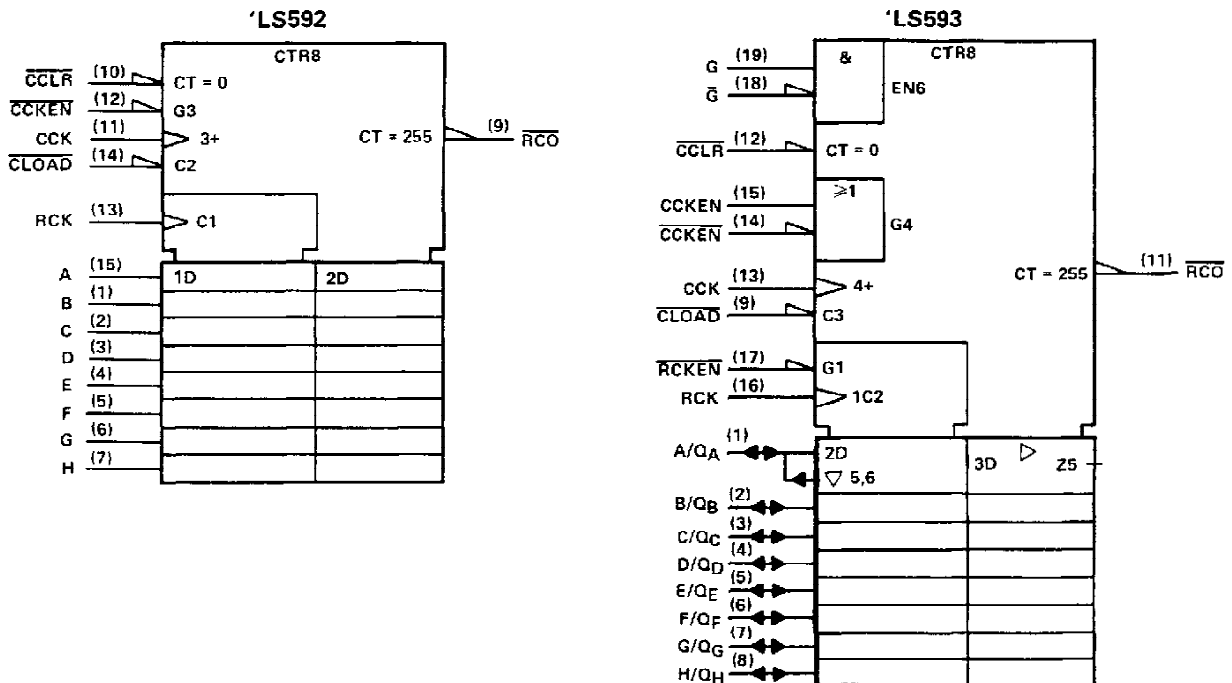

†These symbols are in accordance with ANSI/IEEE Std. 91-1984 and IEC Publication 617-12. Pin numbers shown are for DW, J, N, and W packages.

SN54LS592, SN74LS592 8-BIT BINARY COUNTERS WITH INPUT REGISTERS

logic diagram (positive logic)

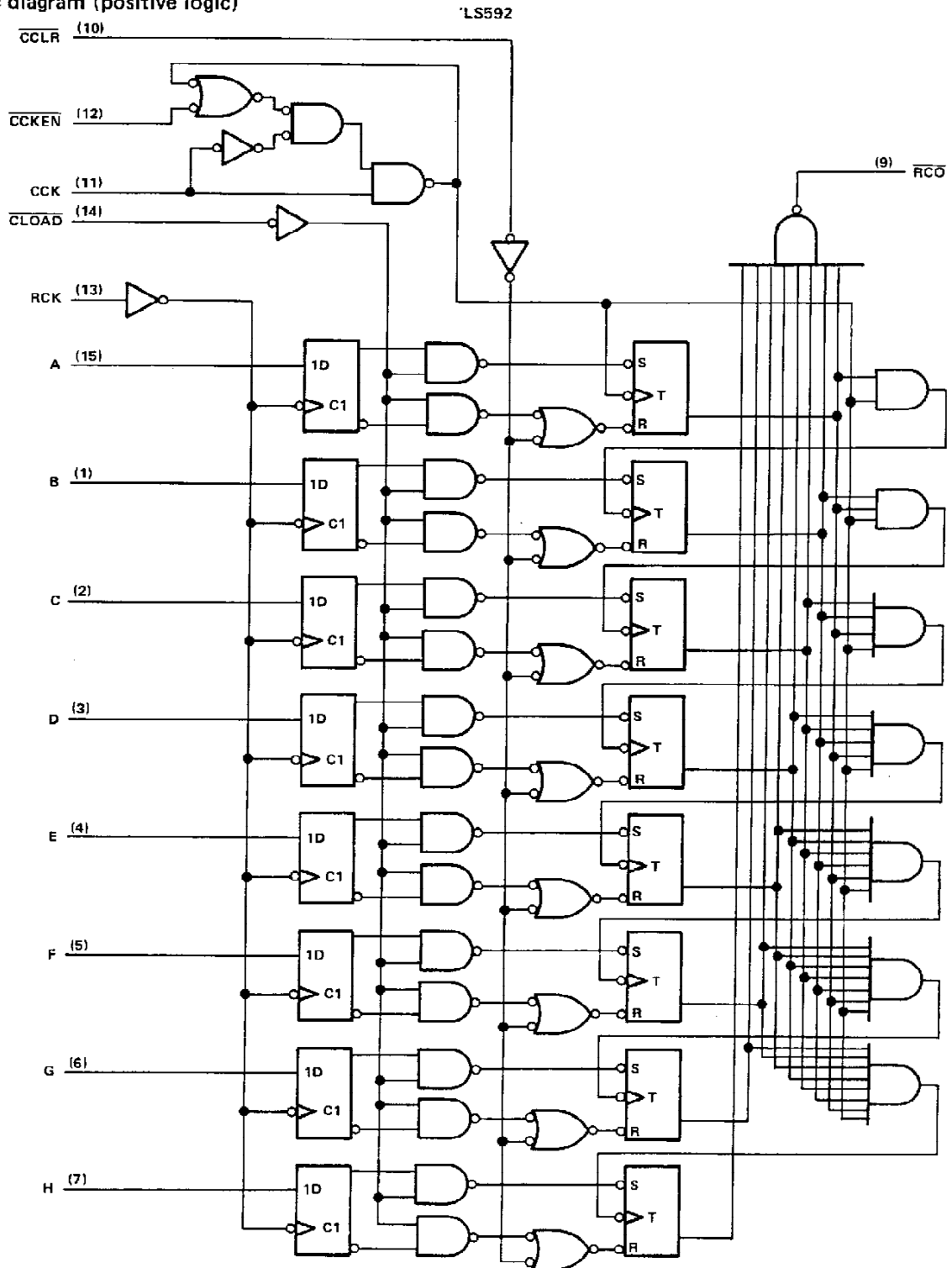

Pin numbers shown are for J, N, and W packages.

SN54LS593, SN74LS593 8-BIT BINARY COUNTERS WITH INPUT REGISTERS

Logic diagram (positive logic)

'LS593

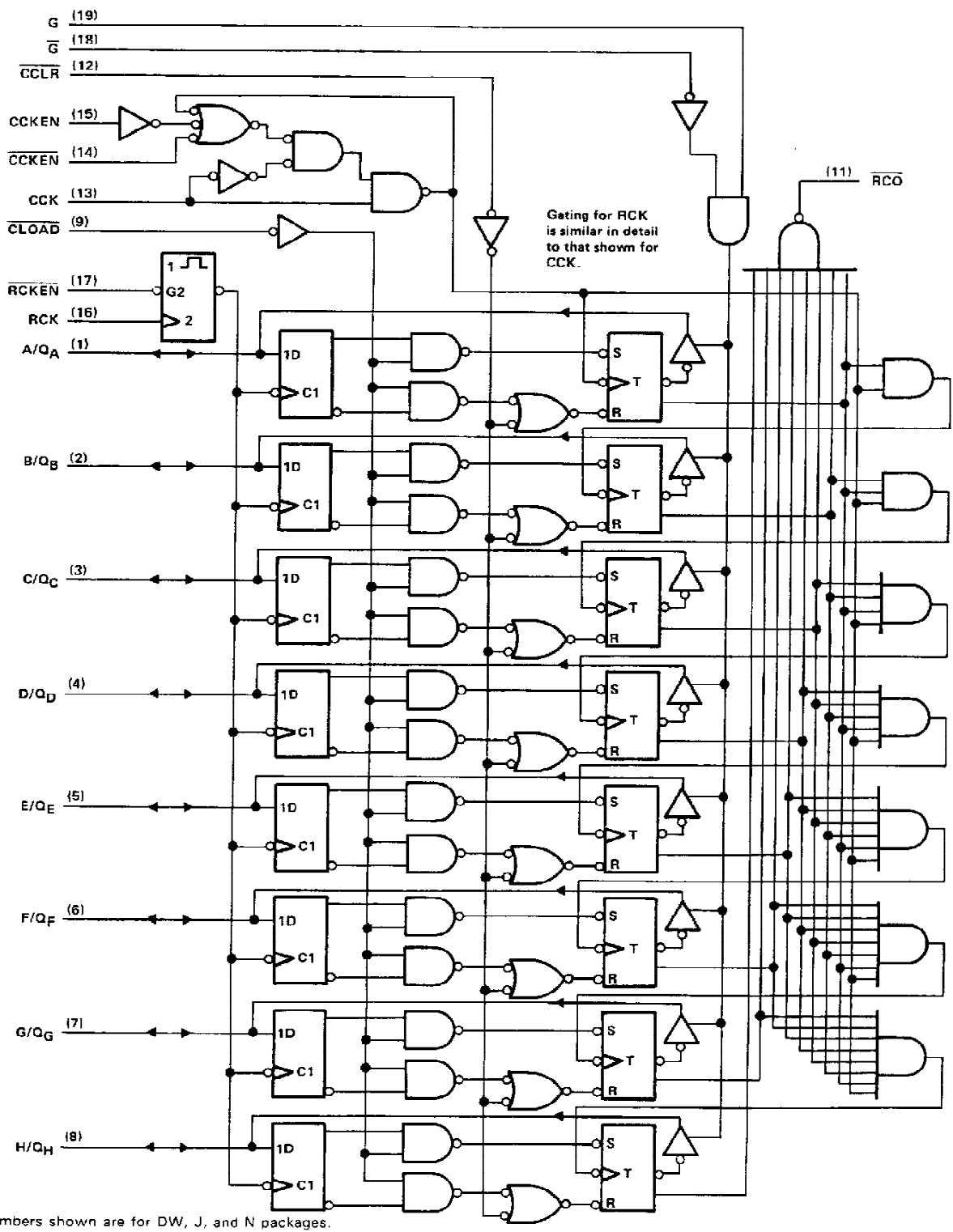

Pin numbers shown are for DW, J, and N packages.

**SN54LS592, SN54LS593, SN74LS592, SN74LS593
8-BIT BINARY COUNTERS WITH INPUT REGISTERS**

typical operating sequences

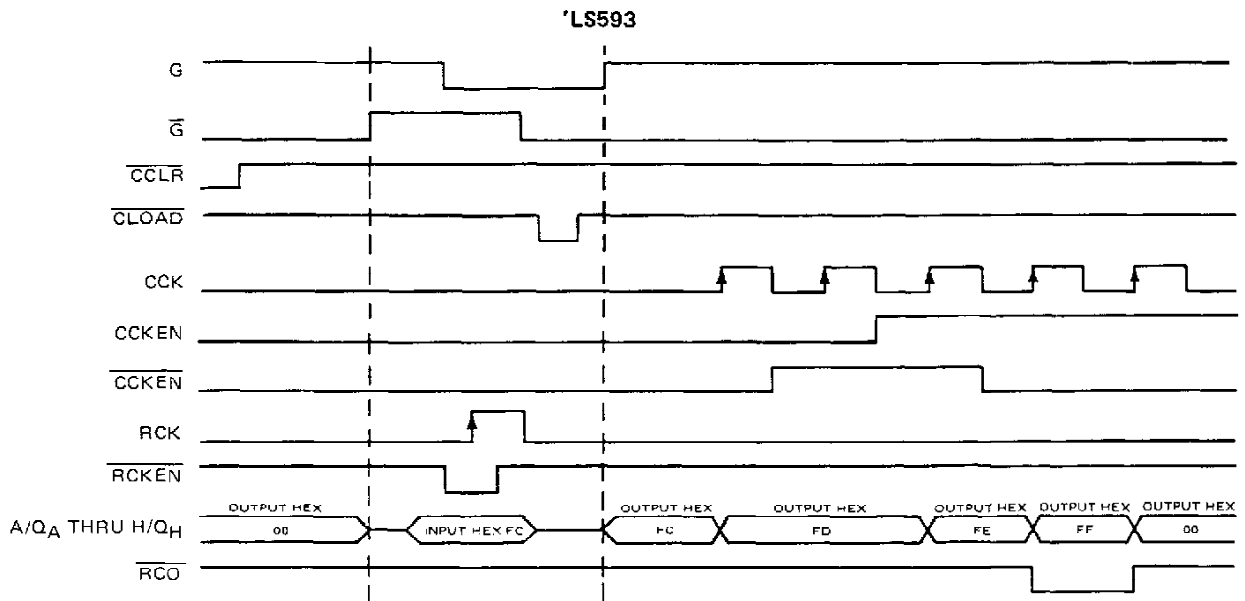
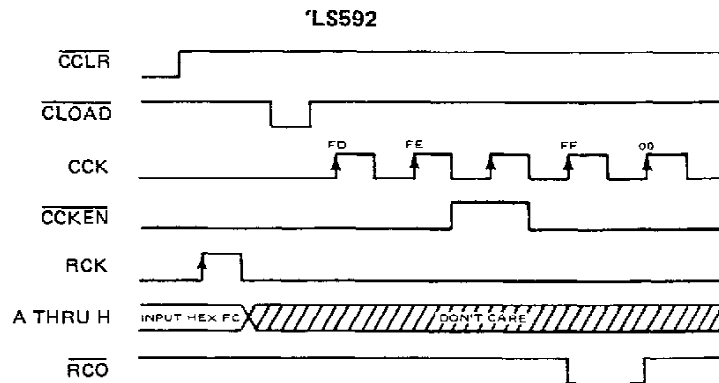

SN54LS592, SN54LS593, SN74LS592, SN74LS593

8-BIT BINARY COUNTERS WITH INPUT REGISTERS

absolute maximum ratings over operating free-air temperature range (unless otherwise noted)

Supply voltage, V_{CC} (see Note 1)	7 V
Input voltage (excluding I/O ports)	7 V
Off-state output voltage (including I/O ports)	5.5 V
Operating free-air temperature range: SN54LS592, SN54LS593	-55°C to 125°C
SN74LS592, SN74LS593	0°C to 70°C
Storage temperature range	-65°C to 150°C

NOTE 1: Voltage values are with respect to the network ground terminal.

recommended operating conditions

		SN54LS'			SN74LS'			UNIT
		MIN	NOM	MAX	MIN	NOM	MAX	
V_{CC}	Supply voltage	4.5	5	5.5	4.75	5	5.25	V
V_{IH}	High-level input voltage	2			2			V
V_{IL}	Low-level input voltage			0.7			0.8	V
I_{OH}	High-level output current	\overline{RCK}		-1	\overline{RCK}		-1	mA
		Q 'LS593 only		-1	Q 'LS593 only		-2.6	
I_{OL}	Low-level output current	\overline{RCK}		8	\overline{RCK}		16	mA
		Q 'LS593 only		12	Q 'LS593 only		24	
f_{CCK}	Counter clock frequency	0		20	0		20	MHz
$t_w(\overline{CCK})$	Duration of counter clock pulse	25			25			ns
$t_w(\overline{CCLR})$	Duration of counter clear pulse	20			20			ns
$t_w(\overline{RCK})$	Duration of register clock pulse	20			20			ns
$t_w(\overline{CLOAD})$	Duration of counter load pulse	40			40			ns
t_{su}	Register enable setup time	\overline{RCKEN} low to $\overline{RCK} \uparrow$, 'LS593		20	\overline{RCKEN} low to $\overline{RCK} \uparrow$, 'LS593		20	ns
t_{su}	Counter enable setup time before $\overline{CCK} \uparrow$	\overline{CCKEN} low, 'LS592		30	\overline{CCKEN} low, 'LS592		30	ns
		\overline{CCKEN} low or \overline{CCKEN} high, 'LS593		30	\overline{CCKEN} low or \overline{CCKEN} high, 'LS593		30	
		\overline{CCLR} inactive before $\overline{CCK} \uparrow$		20	\overline{CCLR} inactive before $\overline{CCK} \uparrow$		20	
t_{su}	Setup time	\overline{CLOAD} inactive before $\overline{CCK} \uparrow$		20	\overline{CLOAD} inactive before $\overline{CCK} \uparrow$		20	ns
		$\overline{RCK} \uparrow$ before $\overline{CLOAD} \uparrow$ (see Note 2)		30	$\overline{RCK} \uparrow$ before $\overline{CLOAD} \uparrow$ (see Note 2)		30	
		Data A thru H before $\overline{RCK} \uparrow$		20	Data A thru H before $\overline{RCK} \uparrow$		20	
		Data A thru H after $\overline{RCK} \uparrow$		0	Data A thru H after $\overline{RCK} \uparrow$		0	
t_h	Hold time	Data A thru H after $\overline{RCK} \uparrow$		0	Data A thru H after $\overline{RCK} \uparrow$		0	ns
		All others		0	All others		0	
T_A	Operating free-air temperature	-55		125	0		70	°C

NOTE 2: This time insures the data saved by $\overline{RCK} \uparrow$ will also be loaded into the counter.



POST OFFICE BOX 655012 • DALLAS, TEXAS 75265

SN54LS592, SN54LS593, SN74LS592, SN74LS593 8-BIT BINARY COUNTERS WITH INPUT REGISTERS

electrical characteristics over recommended operating free-air temperature range (unless otherwise noted)

PARAMETER	TEST CONDITIONS†	SN54LS*		SN74LS*		UNIT			
		MIN	TYP‡	MAX	MIN		TYP‡	MAX	
V_{IK}	$V_{CC} = \text{MIN.}, I_I = -18 \text{ mA}$			-1.5		-1.5	V		
V_{OH}	$V_{CC} = \text{MIN.}, V_{IH} = 2 \text{ V.}, V_{IL} = \text{MAX.}$	$I_{OH} = -1 \text{ mA}$		2.4	3.2		V		
		$I_{OH} = -2.6 \text{ mA}$				2.4		3.1	
		$I_{OH} = -1 \text{ mA}$		2.4	3.2	2.4		3.2	
V_{OL}	$V_{CC} = \text{MIN.}, V_{IH} = 2 \text{ V.}, V_{IL} = \text{MAX.}$	$I_{OL} = 12 \text{ mA}$			0.25	0.4	V		
		$I_{OL} = 24 \text{ mA}$				0.35		0.5	
		$I_{OL} = 8 \text{ mA}$			0.25	0.4		0.25	0.4
		$I_{OL} = 16 \text{ mA}$				0.35		0.5	
I_{OZH}	$V_{CC} = \text{MAX.}, V_{IH} = 2 \text{ V.}, V_{IL} = \text{MAX.}, V_O = 2.7 \text{ V}$					20	μA		
I_{OZL}	$V_{CC} = \text{MAX.}, V_{IH} = 2 \text{ V.}, V_{IL} = \text{MAX.}, V_O = 0.4 \text{ V}$					-0.4	mA		
I_I	$V_{CC} = \text{MAX.}$	$V_I = 5.5 \text{ V}$				0.1	mA		
		$V_I = 7 \text{ V}$				0.1			
I_{IH}	$V_{CC} = \text{MAX.}, V_I = 2.7 \text{ V}$					20	μA		
I_{IL}	$V_{CC} = \text{MAX.}, V_I = 0.4 \text{ V}$	CCK				-0.8	-0.8	mA	
		RCK	'LS592			-0.2	-0.2		
			'LS593			-0.8	-0.8		
		A thru H				-0.4	-0.4		
		Others				-0.2	-0.2		
I_{OS}^{\S}	$V_{CC} = \text{MAX.}, V_O = 0 \text{ V}$	'LS593 Q		-30	-130	-30	-130	mA	
		RCO		-20	-100	-20	-100		
I_{CC}	$V_{CC} = \text{MAX.},$ All possible inputs grounded, All outputs open	'LS592	I_{CCH}	40	60	40	60	mA	
			I_{CCL}	40	60	40	60		
		'LS593	I_{CCH}	47	70	47	70		
			I_{CCL}	53	80	53	80		
			I_{CCZ}	57	85	57	85		

†For conditions shown as MIN or MAX, use the appropriate value specified under recommended operating conditions.

‡All typical values are at $V_{CC} = 5 \text{ V.}, T_A = 25^\circ\text{C.}$

§Not more than one output should be shorted at a time and the duration of the short-circuit should not exceed one second.

TEXAS 
INSTRUMENTS

PDS™ OFFICE BOX 655012 • DALLAS, TEXAS 75265

SN54LS592, SN54LS593, SN74LS592, SN74LS593
8-BIT BINARY COUNTERS WITH INPUT REGISTERS

switching characteristics, $V_{CC} = 5\text{ V}$, $T_A = 25^\circ\text{C}$, (see note 3)

PARAMETER	FROM (INPUT)	TO (OUTPUT)	TEST CONDITIONS	'LS592			'LS593			UNIT
				MIN	TYP	MAX	MIN	TYP	MAX	
f_{max}	CCK ↑	\overline{RCO}	$R_L = 1\text{ k}\Omega$, $C_L = 30\text{ pF}$	20	35		20	35		MHz
t_{PLH}	CCK ↑	Q	$R_L = 667\ \Omega$, $C_L = 45\text{ pF}$				14	21		ns
t_{PHL}	CCK ↑	Q					26	39		ns
t_{PLH}	\overline{CLOAD} ↓	Q					34	51		ns
t_{PHL}	\overline{CLOAD} ↓	Q					28	42		ns
t_{PHL}	\overline{CCLR} ↓	Q					25	38		ns
t_{PZH}	G ↑	Q					31	47		ns
t_{PZL}	G ↑	Q					27	40		ns
t_{PZH}	\overline{G} ↓	Q					29	45		ns
t_{PZL}	\overline{G} ↓	Q					31	47		ns
t_{PHZ}	G ↓	Q					33	50		ns
t_{PLZ}	G ↓	Q	$R_L = 667\ \Omega$, $C_L = 5\text{ pF}$				35	52		ns
t_{PHZ}	\overline{G} ↑	Q					26	39		ns
t_{PLZ}	\overline{G} ↑	Q					28	42		ns
t_{PLH}	CCK ↑	\overline{RCO}								
t_{PHL}	CCK ↑	\overline{RCO}	$R_L = 1\text{ k}\Omega$, $C_L = 30\text{ pF}$	15	23		14	21		ns
t_{PLH}	\overline{CLOAD} ↓	\overline{RCO}		20	30		20	30		ns
t_{PHL}	\overline{CLOAD} ↓	\overline{RCO}		31	47		31	47		ns
t_{PLH}	\overline{CCLR} ↓	\overline{RCO}		27	41		27	41		ns
t_{PHL}	\overline{CCLR} ↓	\overline{RCO}		30	45		30	45		ns
t_{PLH}	RCK ↑	\overline{RCO}	$R_L = 1\text{ k}\Omega$, $C_L = 30\text{ pF}$ $\overline{CLOAD} = L$	35	53		42	63		ns
t_{PHL}	RCK ↑	\overline{RCO}		30	45		33	50		ns

NOTE 3: Load circuits and voltage waveforms are shown in Section 1.

PACKAGING INFORMATION

Orderable part number	Status (1)	Material type (2)	Package Pins	Package qty Carrier	RoHS (3)	Lead finish/ Ball material (4)	MSL rating/ Peak reflow (5)	Op temp (°C)	Part marking (6)
5962-8762101EA	Active	Production	CDIP (J) 16	25 TUBE	No	SNPB	N/A for Pkg Type	-55 to 125	5962-8762101EA SNJ54LS592J
5962-8762101FA	Active	Production	CFP (W) 16	25 TUBE	No	SNPB	N/A for Pkg Type	-55 to 125	5962-8762101FA SNJ54LS592W
5962-8762101FA	Active	Production	CFP (W) 16	25 TUBE	No	SNPB	N/A for Pkg Type	-55 to 125	5962-8762101FA SNJ54LS592W
SN54LS592J	Active	Production	CDIP (J) 16	25 TUBE	No	SNPB	N/A for Pkg Type	-55 to 125	SN54LS592J
SN54LS592J	Active	Production	CDIP (J) 16	25 TUBE	No	SNPB	N/A for Pkg Type	-55 to 125	SN54LS592J
SN54LS592J.A	Active	Production	CDIP (J) 16	25 TUBE	No	SNPB	N/A for Pkg Type	-55 to 125	SN54LS592J
SN54LS592J.A	Active	Production	CDIP (J) 16	25 TUBE	No	SNPB	N/A for Pkg Type	-55 to 125	SN54LS592J
SN54LS593J	Active	Production	CDIP (J) 20	20 TUBE	No	SNPB	N/A for Pkg Type	-55 to 125	SN54LS593J
SN54LS593J	Active	Production	CDIP (J) 20	20 TUBE	No	SNPB	N/A for Pkg Type	-55 to 125	SN54LS593J
SN54LS593J.A	Active	Production	CDIP (J) 20	20 TUBE	No	SNPB	N/A for Pkg Type	-55 to 125	SN54LS593J
SN54LS593J.A	Active	Production	CDIP (J) 20	20 TUBE	No	SNPB	N/A for Pkg Type	-55 to 125	SN54LS593J
SN74LS592D	Active	Production	SOIC (D) 16	40 TUBE	Yes	NIPDAU	Level-1-260C-UNLIM	0 to 70	LS592
SN74LS592D	Active	Production	SOIC (D) 16	40 TUBE	Yes	NIPDAU	Level-1-260C-UNLIM	0 to 70	LS592
SN74LS592D.A	Active	Production	SOIC (D) 16	40 TUBE	Yes	NIPDAU	Level-1-260C-UNLIM	0 to 70	LS592
SN74LS592D.A	Active	Production	SOIC (D) 16	40 TUBE	Yes	NIPDAU	Level-1-260C-UNLIM	0 to 70	LS592
SN74LS592N	Active	Production	PDIP (N) 16	25 TUBE	Yes	NIPDAU	N/A for Pkg Type	0 to 70	SN74LS592N
SN74LS592N	Active	Production	PDIP (N) 16	25 TUBE	Yes	NIPDAU	N/A for Pkg Type	0 to 70	SN74LS592N
SN74LS592N.A	Active	Production	PDIP (N) 16	25 TUBE	Yes	NIPDAU	N/A for Pkg Type	0 to 70	SN74LS592N
SN74LS592N.A	Active	Production	PDIP (N) 16	25 TUBE	Yes	NIPDAU	N/A for Pkg Type	0 to 70	SN74LS592N
SN74LS592NSR	Active	Production	SOP (NS) 16	2000 LARGE T&R	Yes	NIPDAU	Level-1-260C-UNLIM	0 to 70	74LS592
SN74LS592NSR	Active	Production	SOP (NS) 16	2000 LARGE T&R	Yes	NIPDAU	Level-1-260C-UNLIM	0 to 70	74LS592
SN74LS592NSR.A	Active	Production	SOP (NS) 16	2000 LARGE T&R	Yes	NIPDAU	Level-1-260C-UNLIM	0 to 70	74LS592
SN74LS592NSR.A	Active	Production	SOP (NS) 16	2000 LARGE T&R	Yes	NIPDAU	Level-1-260C-UNLIM	0 to 70	74LS592
SN74LS593DW	Obsolete	Production	SOIC (DW) 20	-	-	Call TI	Call TI	0 to 70	LS593
SN74LS593DW	Obsolete	Production	SOIC (DW) 20	-	-	Call TI	Call TI	0 to 70	LS593
SN74LS593DWR	Active	Production	SOIC (DW) 20	2000 LARGE T&R	Yes	NIPDAU	Level-1-260C-UNLIM	0 to 70	LS593
SN74LS593DWR	Active	Production	SOIC (DW) 20	2000 LARGE T&R	Yes	NIPDAU	Level-1-260C-UNLIM	0 to 70	LS593

Orderable part number	Status (1)	Material type (2)	Package Pins	Package qty Carrier	RoHS (3)	Lead finish/ Ball material (4)	MSL rating/ Peak reflow (5)	Op temp (°C)	Part marking (6)
SN74LS593DWR.A	Active	Production	SOIC (DW) 20	2000 LARGE T&R	Yes	NIPDAU	Level-1-260C-UNLIM	0 to 70	LS593
SN74LS593DWR.A	Active	Production	SOIC (DW) 20	2000 LARGE T&R	Yes	NIPDAU	Level-1-260C-UNLIM	0 to 70	LS593
SN74LS593N	Active	Production	PDIP (N) 20	20 TUBE	Yes	NIPDAU	N/A for Pkg Type	0 to 70	SN74LS593N
SN74LS593N	Active	Production	PDIP (N) 20	20 TUBE	Yes	NIPDAU	N/A for Pkg Type	0 to 70	SN74LS593N
SN74LS593N.A	Active	Production	PDIP (N) 20	20 TUBE	Yes	NIPDAU	N/A for Pkg Type	0 to 70	SN74LS593N
SN74LS593N.A	Active	Production	PDIP (N) 20	20 TUBE	Yes	NIPDAU	N/A for Pkg Type	0 to 70	SN74LS593N
SNJ54LS592J	Active	Production	CDIP (J) 16	25 TUBE	No	SNPB	N/A for Pkg Type	-55 to 125	5962-8762101EA SNJ54LS592J
SNJ54LS592J	Active	Production	CDIP (J) 16	25 TUBE	No	SNPB	N/A for Pkg Type	-55 to 125	5962-8762101EA SNJ54LS592J
SNJ54LS592J.A	Active	Production	CDIP (J) 16	25 TUBE	No	SNPB	N/A for Pkg Type	-55 to 125	5962-8762101EA SNJ54LS592J
SNJ54LS592J.A	Active	Production	CDIP (J) 16	25 TUBE	No	SNPB	N/A for Pkg Type	-55 to 125	5962-8762101EA SNJ54LS592J
SNJ54LS592W	Active	Production	CFP (W) 16	25 TUBE	No	SNPB	N/A for Pkg Type	-55 to 125	5962-8762101FA SNJ54LS592W
SNJ54LS592W	Active	Production	CFP (W) 16	25 TUBE	No	SNPB	N/A for Pkg Type	-55 to 125	5962-8762101FA SNJ54LS592W
SNJ54LS592W.A	Active	Production	CFP (W) 16	25 TUBE	No	SNPB	N/A for Pkg Type	-55 to 125	5962-8762101FA SNJ54LS592W
SNJ54LS592W.A	Active	Production	CFP (W) 16	25 TUBE	No	SNPB	N/A for Pkg Type	-55 to 125	5962-8762101FA SNJ54LS592W
SNJ54LS593J	Active	Production	CDIP (J) 20	20 TUBE	No	SNPB	N/A for Pkg Type	-55 to 125	SNJ54LS593J
SNJ54LS593J	Active	Production	CDIP (J) 20	20 TUBE	No	SNPB	N/A for Pkg Type	-55 to 125	SNJ54LS593J
SNJ54LS593J.A	Active	Production	CDIP (J) 20	20 TUBE	No	SNPB	N/A for Pkg Type	-55 to 125	SNJ54LS593J
SNJ54LS593J.A	Active	Production	CDIP (J) 20	20 TUBE	No	SNPB	N/A for Pkg Type	-55 to 125	SNJ54LS593J

(1) **Status:** For more details on status, see our [product life cycle](#).

(2) **Material type:** When designated, preproduction parts are prototypes/experimental devices, and are not yet approved or released for full production. Testing and final process, including without limitation quality assurance, reliability performance testing, and/or process qualification, may not yet be complete, and this item is subject to further changes or possible discontinuation. If available for ordering, purchases will be subject to an additional waiver at checkout, and are intended for early internal evaluation purposes only. These items are sold without warranties of any kind.

(3) **RoHS values:** Yes, No, RoHS Exempt. See the [TI RoHS Statement](#) for additional information and value definition.

(4) **Lead finish/Ball material:** Parts may have multiple material finish options. Finish options are separated by a vertical ruled line. Lead finish/Ball material values may wrap to two lines if the finish value exceeds the maximum column width.

(5) **MSL rating/Peak reflow:** The moisture sensitivity level ratings and peak solder (reflow) temperatures. In the event that a part has multiple moisture sensitivity ratings, only the lowest level per JEDEC standards is shown. Refer to the shipping label for the actual reflow temperature that will be used to mount the part to the printed circuit board.

(6) **Part marking:** There may be an additional marking, which relates to the logo, the lot trace code information, or the environmental category of the part.

Multiple part markings will be inside parentheses. Only one part marking contained in parentheses and separated by a "~" will appear on a part. If a line is indented then it is a continuation of the previous line and the two combined represent the entire part marking for that device.

Important Information and Disclaimer: The information provided on this page represents TI's knowledge and belief as of the date that it is provided. TI bases its knowledge and belief on information provided by third parties, and makes no representation or warranty as to the accuracy of such information. Efforts are underway to better integrate information from third parties. TI has taken and continues to take reasonable steps to provide representative and accurate information but may not have conducted destructive testing or chemical analysis on incoming materials and chemicals. TI and TI suppliers consider certain information to be proprietary, and thus CAS numbers and other limited information may not be available for release.

In no event shall TI's liability arising out of such information exceed the total purchase price of the TI part(s) at issue in this document sold by TI to Customer on an annual basis.

OTHER QUALIFIED VERSIONS OF SN54LS592, SN54LS593, SN74LS592, SN74LS593 :

● Catalog : [SN74LS592](#), [SN74LS593](#)

● Military : [SN54LS592](#), [SN54LS593](#)

NOTE: Qualified Version Definitions:

● Catalog - TI's standard catalog product

● Military - QML certified for Military and Defense Applications

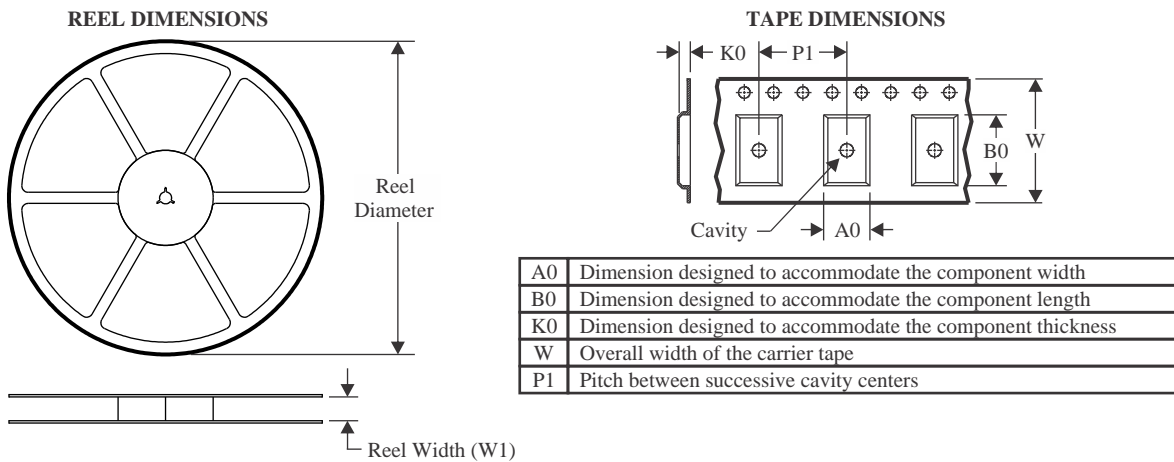
TAPE AND REEL INFORMATION

QUADRANT ASSIGNMENTS FOR PIN 1 ORIENTATION IN TAPE

*All dimensions are nominal

Device	Package Type	Package Drawing	Pins	SPQ	Reel Diameter (mm)	Reel Width W1 (mm)	A0 (mm)	B0 (mm)	K0 (mm)	P1 (mm)	W (mm)	Pin1 Quadrant
SN74LS592NSR	SOP	NS	16	2000	330.0	16.4	8.1	10.4	2.5	12.0	16.0	Q1
SN74LS593DWR	SOIC	DW	20	2000	330.0	24.4	10.8	13.3	2.7	12.0	24.0	Q1

TAPE AND REEL BOX DIMENSIONS

*All dimensions are nominal

Device	Package Type	Package Drawing	Pins	SPQ	Length (mm)	Width (mm)	Height (mm)
SN74LS592NSR	SOP	NS	16	2000	353.0	353.0	32.0
SN74LS593DWR	SOIC	DW	20	2000	356.0	356.0	45.0

TUBE

*All dimensions are nominal

Device	Package Name	Package Type	Pins	SPQ	L (mm)	W (mm)	T (μm)	B (mm)
5962-8762101FA	W	CFP	16	25	506.98	26.16	6220	NA
SN74LS592D	D	SOIC	16	40	507	8	3940	4.32
SN74LS592D.A	D	SOIC	16	40	507	8	3940	4.32
SN74LS592N	N	PDIP	16	25	506	13.97	11230	4.32
SN74LS592N	N	PDIP	16	25	506	13.97	11230	4.32
SN74LS592N.A	N	PDIP	16	25	506	13.97	11230	4.32
SN74LS592N.A	N	PDIP	16	25	506	13.97	11230	4.32
SN74LS593N	N	PDIP	20	20	506	13.97	11230	4.32
SN74LS593N.A	N	PDIP	20	20	506	13.97	11230	4.32
SNJ54LS592W	W	CFP	16	25	506.98	26.16	6220	NA
SNJ54LS592W.A	W	CFP	16	25	506.98	26.16	6220	NA

D (R-PDSO-G16)

PLASTIC SMALL OUTLINE



- NOTES:
- A. All linear dimensions are in inches (millimeters).
 - B. This drawing is subject to change without notice.
 - C. Body length does not include mold flash, protrusions, or gate burrs. Mold flash, protrusions, or gate burrs shall not exceed 0.006 (0,15) each side.
 - D. Body width does not include interlead flash. Interlead flash shall not exceed 0.017 (0,43) each side.
 - E. Reference JEDEC MS-012 variation AC.

J (R-GDIP-T**)

14 LEADS SHOWN

CERAMIC DUAL IN-LINE PACKAGE



DIM \ PINS **	14	16	18	20
A	0.300 (7,62) BSC	0.300 (7,62) BSC	0.300 (7,62) BSC	0.300 (7,62) BSC
B MAX	0.785 (19,94)	.840 (21,34)	0.960 (24,38)	1.060 (26,92)
B MIN	—	—	—	—
C MAX	0.300 (7,62)	0.300 (7,62)	0.310 (7,87)	0.300 (7,62)
C MIN	0.245 (6,22)	0.245 (6,22)	0.220 (5,59)	0.245 (6,22)



4040083/F 03/03

- NOTES:
- All linear dimensions are in inches (millimeters).
 - This drawing is subject to change without notice.
 - This package is hermetically sealed with a ceramic lid using glass frit.
 - Index point is provided on cap for terminal identification only on press ceramic glass frit seal only.
 - Falls within MIL STD 1835 GDIP1-T14, GDIP1-T16, GDIP1-T18 and GDIP1-T20.

W (R-GDFP-F16)

CERAMIC DUAL FLATPACK



- NOTES:
- A. All linear dimensions are in inches (millimeters).
 - B. This drawing is subject to change without notice.
 - C. This package can be hermetically sealed with a ceramic lid using glass frit.
 - D. Index point is provided on cap for terminal identification only.
 - E. Falls within MIL STD 1835 GDFP2-F16

J (R-GDIP-T**)

14 LEADS SHOWN

CERAMIC DUAL IN-LINE PACKAGE



DIM \ PINS **	14	16	18	20
A	0.300 (7,62) BSC	0.300 (7,62) BSC	0.300 (7,62) BSC	0.300 (7,62) BSC
B MAX	0.785 (19,94)	.840 (21,34)	0.960 (24,38)	1.060 (26,92)
B MIN	—	—	—	—
C MAX	0.300 (7,62)	0.300 (7,62)	0.310 (7,87)	0.300 (7,62)
C MIN	0.245 (6,22)	0.245 (6,22)	0.220 (5,59)	0.245 (6,22)



4040083/F 03/03

- NOTES:
- A. All linear dimensions are in inches (millimeters).
 - B. This drawing is subject to change without notice.
 - C. This package is hermetically sealed with a ceramic lid using glass frit.
 - D. Index point is provided on cap for terminal identification only on press ceramic glass frit seal only.
 - E. Falls within MIL STD 1835 GDIP1-T14, GDIP1-T16, GDIP1-T18 and GDIP1-T20.



PACKAGE OUTLINE

NS0016A

SOP - 2.00 mm max height

SOP



4220735/A 12/2021

NOTES:

1. All linear dimensions are in millimeters. Dimensions in parenthesis are for reference only. Dimensioning and tolerancing per ASME Y14.5M.
2. This drawing is subject to change without notice.
3. This dimension does not include mold flash, protrusions, or gate burrs. Mold flash, protrusions, or gate burrs shall not exceed 0.15 mm, per side.
4. This dimension does not include interlead flash. Interlead flash shall not exceed 0.25 mm, per side.

EXAMPLE BOARD LAYOUT

NS0016A

SOP - 2.00 mm max height

SOP



4220735/A 12/2021

NOTES: (continued)

5. Publication IPC-7351 may have alternate designs.

6. Solder mask tolerances between and around signal pads can vary based on board fabrication site.

EXAMPLE STENCIL DESIGN

NS0016A

SOP - 2.00 mm max height

SOP



SOLDER PASTE EXAMPLE
BASED ON 0.125 mm THICK STENCIL
SCALE:7X

4220735/A 12/2021

NOTES: (continued)

7. Laser cutting apertures with trapezoidal walls and rounded corners may offer better paste release. IPC-7525 may have alternate design recommendations.
8. Board assembly site may have different recommendations for stencil design.

N (R-PDIP-T**)

PLASTIC DUAL-IN-LINE PACKAGE

16 PINS SHOWN



- NOTES:
- A. All linear dimensions are in inches (millimeters).
 - B. This drawing is subject to change without notice.
 - Falls within JEDEC MS-001, except 18 and 20 pin minimum body length (Dim A).
 - The 20 pin end lead shoulder width is a vendor option, either half or full width.

DW0020A



PACKAGE OUTLINE

SOIC - 2.65 mm max height

SOIC



4220724/A 05/2016

NOTES:

1. All linear dimensions are in millimeters. Dimensions in parenthesis are for reference only. Dimensioning and tolerancing per ASME Y14.5M.
2. This drawing is subject to change without notice.
3. This dimension does not include mold flash, protrusions, or gate burrs. Mold flash, protrusions, or gate burrs shall not exceed 0.15 mm per side.
4. This dimension does not include interlead flash. Interlead flash shall not exceed 0.43 mm per side.
5. Reference JEDEC registration MS-013.

EXAMPLE BOARD LAYOUT

DW0020A

SOIC - 2.65 mm max height

SOIC



LAND PATTERN EXAMPLE
SCALE:6X



SOLDER MASK DETAILS

4220724/A 05/2016

NOTES: (continued)

- 6. Publication IPC-7351 may have alternate designs.
- 7. Solder mask tolerances between and around signal pads can vary based on board fabrication site.

EXAMPLE STENCIL DESIGN

DW0020A

SOIC - 2.65 mm max height

SOIC

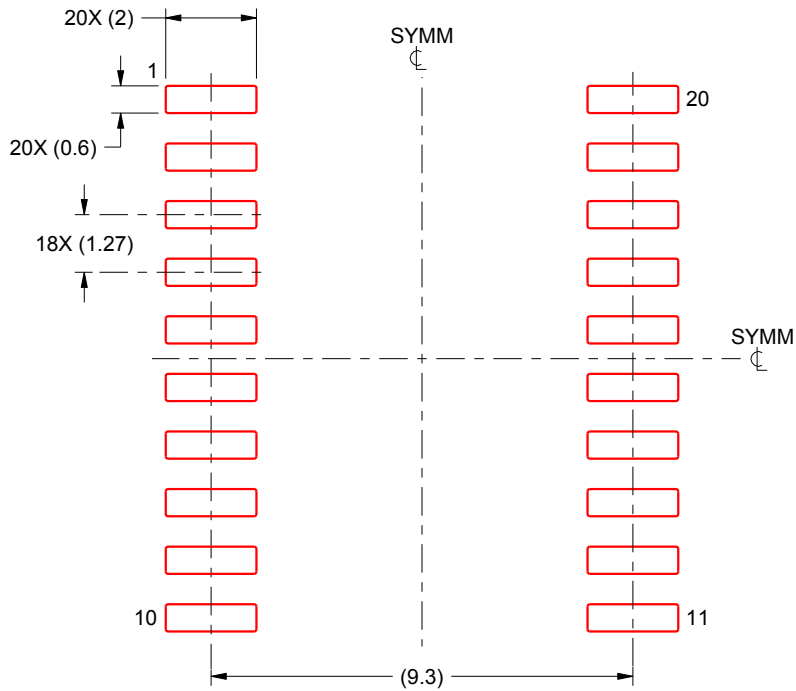

SOLDER PASTE EXAMPLE
BASED ON 0.125 mm THICK STENCIL
SCALE:6X

4220724/A 05/2016

NOTES: (continued)

8. Laser cutting apertures with trapezoidal walls and rounded corners may offer better paste release. IPC-7525 may have alternate design recommendations.
9. Board assembly site may have different recommendations for stencil design.

IMPORTANT NOTICE AND DISCLAIMER

TI PROVIDES TECHNICAL AND RELIABILITY DATA (INCLUDING DATASHEETS), DESIGN RESOURCES (INCLUDING REFERENCE DESIGNS), APPLICATION OR OTHER DESIGN ADVICE, WEB TOOLS, SAFETY INFORMATION, AND OTHER RESOURCES "AS IS" AND WITH ALL FAULTS, AND DISCLAIMS ALL WARRANTIES, EXPRESS AND IMPLIED, INCLUDING WITHOUT LIMITATION ANY IMPLIED WARRANTIES OF MERCHANTABILITY, FITNESS FOR A PARTICULAR PURPOSE OR NON-INFRINGEMENT OF THIRD PARTY INTELLECTUAL PROPERTY RIGHTS.

These resources are intended for skilled developers designing with TI products. You are solely responsible for (1) selecting the appropriate TI products for your application, (2) designing, validating and testing your application, and (3) ensuring your application meets applicable standards, and any other safety, security, regulatory or other requirements.

These resources are subject to change without notice. TI grants you permission to use these resources only for development of an application that uses the TI products described in the resource. Other reproduction and display of these resources is prohibited. No license is granted to any other TI intellectual property right or to any third party intellectual property right. TI disclaims responsibility for, and you fully indemnify TI and its representatives against any claims, damages, costs, losses, and liabilities arising out of your use of these resources.

TI's products are provided subject to [TI's Terms of Sale](#), [TI's General Quality Guidelines](#), or other applicable terms available either on ti.com or provided in conjunction with such TI products. TI's provision of these resources does not expand or otherwise alter TI's applicable warranties or warranty disclaimers for TI products. Unless TI explicitly designates a product as custom or customer-specified, TI products are standard, catalog, general purpose devices.

TI objects to and rejects any additional or different terms you may propose.

Copyright © 2026, Texas Instruments Incorporated

Last updated 10/2025