

SN65MLVD203B Full-Duplex Type-1 Multipoint-LVDS Transceiver With IEC ESD Protection

1 Features

- Compatible with the M-LVDS standard TIA/EIA-899 for multipoint data interchange
- Low-voltage differential 30-Ω to 55-Ω line driver and receiver for signaling rates⁽¹⁾ up to 200 Mbps, clock frequencies up to 100 MHz
 - Type-1 receiver incorporates 25 mV of hysteresis
- Bus I/O protection
 - ±8-kV HBM
 - ±8-kV IEC 61000-4-2 contact discharge
- Controlled driver output voltage transition times for improved signal quality
- –1-V to 3.4-V common-mode voltage range allows data transfer with 2 V of ground noise
- Bus pins high impedance when disabled or $V_{CC} \leq 1.5$ V
- 100-Mbps device available (SN65MLVD202B)
- Improved alternatives to SN65MLVD203¹

2 Applications

- Low-power, high-speed, and short-reach alternative to TIA/EIA-485
- Backplane or cabled multipoint data and clock transmission
- [Cellular base stations](#)
- [Central office switches](#)
- [Network switches and routers](#)

3 Description

The SN65MLVD203B device is a multipoint low-voltage differential signaling (M-LVDS) line driver and receiver which is optimized to operate at signaling rates up to 200 Mbps. This device has a robust 3.3-V driver and receiver in the standard QFN footprint for demanding industrial applications. The bus pins are robust to ESD events, with high levels of protection to human-body model and IEC contact discharge specifications.

The device combines a differential driver and a differential receiver (transceiver), which operates from a single 3.3-V supply. The transceiver is optimized to operate at signaling rates up to 200 Mbps.

The SN65MLVD203B has enhancements over similar devices. Improved features include a controlled slew rate on the driver output to help minimize reflections from unterminated stubs, resulting in better signal integrity. The devices are characterized for operation from –40°C to 125°C.

The SN65MLVD203B M-LVDS transceiver is part of the TI extensive [M-LVDS portfolio](#).

Package Information⁽¹⁾

PART NUMBER	PACKAGE	BODY SIZE (NOM)
SN65MLVD203B	RUM (WQFN, 16)	4.00 mm × 4.00 mm

(1) For all available packages, see the orderable addendum at the end of the data sheet.

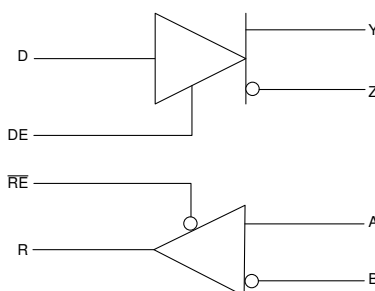

Simplified Schematic, SN65MLVD203B

¹ The signaling rate of a line is the number of voltage transitions that are made per second expressed in the bps of the unit (bits per second).



Table of Contents

1 Features	1	8.1 Overview.....	15
2 Applications	1	8.2 Functional Block Diagrams.....	15
3 Description	1	8.3 Feature Description.....	15
4 Revision History	2	8.4 Device Functional Modes.....	16
5 Pin Configuration and Functions	3	9 Application and Implementation	18
6 Specifications	4	9.1 Application Information.....	18
6.1 Absolute Maximum Ratings	4	9.2 Typical Application.....	18
6.2 ESD Ratings	4	9.3 Power Supply Recommendations.....	23
6.3 Recommended Operating Conditions	4	9.4 Layout.....	23
6.4 Thermal Information	5	10 Device and Documentation Support	28
6.5 Electrical Characteristics	5	10.1 Documentation Support.....	28
6.6 Electrical Characteristics – Driver	5	10.2 Receiving Notification of Documentation Updates.....	28
6.7 Electrical Characteristics – Receiver	7	10.3 Support Resources.....	28
6.8 Switching Characteristics – Driver	7	10.4 Trademarks.....	28
6.9 Switching Characteristics – Receiver	8	10.5 Electrostatic Discharge Caution.....	28
6.10 Typical Characteristics.....	8	10.6 Glossary.....	28
7 Parameter Measurement Information	9	11 Mechanical, Packaging, and Orderable Information	28
8 Detailed Description	15		

4 Revision History

NOTE: Page numbers for previous revisions may differ from page numbers in the current version.

Changes from Revision A (November 2020) to Revision B (November 2022)	Page
• Changed the <i>Device Information</i> table to <i>Package Information</i>	1
• Updated the table note in the <i>Absolute Maximum Ratings</i> section.....	4
• Updated the CDM testing in the ESD Ratings section.....	4
• Added <i>RX Maximum Jitter While DE Toggling</i> section.....	16
• Moved the <i>Power Supply Recommendations</i> and <i>Layout</i> sections to the <i>Application and Implementation</i> section.....	23

Changes from Revision * (September 2020) to Revision A (November 2020)	Page
• Updated device status to <i>Production Data</i>	1
• In Electrical Characteristics - Driver, changed I_{IL} (min) from 0 μ A to -1 μ A.....	5
• In Electrical Characteristics – Receiver, changed I_{IH} (max) from 0 μ A to 1 μ A.....	7
• In Switching Characteristics – Driver, removed $t_{sk(p)}$ pulse skew specification.....	7
• Changed Disabled Time high level to high impedance output from 4 ns typ to 5 ns typ.....	7
• Changed Disable time low level to high impedance output from 4 ns typ to 5 ns typ.....	7
• In Switching Characteristics – Receiver, changed $t_{sk(p)}$ pulse skew max from 300 ps to 600 ps and changed typ from 100 ps to 80 ps.	8

5 Pin Configuration and Functions

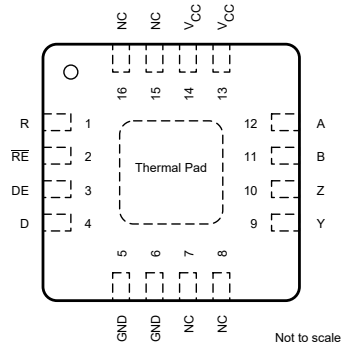

Figure 5-1. RUM Package, 16-Pin WQFN (Top View)

Table 5-1. Pin Functions

PIN		TYPE	DESCRIPTION
NAME	NO.		
R	1	Output	Receiver output
RE	2	Input	Receiver enable pin; High = Disable, Low = Enable
DE	3	Input	Driver enable pin; High = Enable, Low = Disable
D	4	Input	Driver input
GND	5	Power	Supply ground
GND	6	Power	Supply ground
NC	7	NC	No internal connection
NC	8	NC	No internal connection
Y	9	Output	Differential output
Z	10	Output	Differential output
B	11	Input	Differential input
A	12	Input	Differential input
V _{CC}	13	Power	Power supply, 3.3 V
V _{CC}	14	Power	Power supply, 3.3 V
NC	15	NC	No internal connection
NC	16	NC	No internal connection
Thermal Pad		Power	Thermal pad. Connect to a solid ground plane.

6 Specifications

6.1 Absolute Maximum Ratings

over operating free-air temperature range (unless otherwise noted)⁽¹⁾

		MIN	MAX	UNIT
Supply voltage range, V_{CC} ⁽²⁾		-0.5	4	V
Input voltage range	D, DE, \overline{RE}	-0.5	4	V
	A, B	-4	6	V
Output voltage range	R	-0.3	4	V
	Y, Z	-1.8	4	V
Continuous power dissipation		See the <i>Thermal Information</i> table		
Storage temperature, T_{stg}		-65	150	°C

- (1) Operation outside the *Absolute Maximum Ratings* may cause permanent device damage. *Absolute Maximum Ratings* do not imply functional operation of the device at these or any other conditions beyond those listed under *Recommended Operating Conditions*. If used outside the *Recommended Operating Conditions* but within the *Absolute Maximum Ratings*, the device may not be fully functional, and this may affect device reliability, functionality, performance, and shorten the device lifetime.
- (2) All voltage values, except differential I/O bus voltages, are with respect to network ground terminal.

6.2 ESD Ratings

			VALUE	UNIT	
$V_{(ESD)}$	Electrostatic discharge	Contact discharge, per IEC 61000-4-2	A, B, Y and Z	±8000	V
		Human body model (HBM), per ANSI/ESDA/JEDEC JS-001, all pins ⁽¹⁾	A, B, Y and Z	±8000	
			All pins except A, B, Y and Z	±4000	
		Charged device model (CDM), per JEDEC JS-002, all pins ⁽²⁾	All pins	±1500	

- (1) JEDEC document JEP155 states that 500-V HBM allows safe manufacturing with a standard ESD control process.
- (2) JEDEC document JEP157 states that 250-V HBM allows safe manufacturing with a standard ESD control process.

6.3 Recommended Operating Conditions

over operating free-air temperature range (unless otherwise noted)

		MIN	NOM	MAX	UNIT
V_{CC}	Supply voltage	3	3.3	3.6	V
V_{IH}	High-level input voltage	2		V_{CC}	V
V_{IL}	Low-level input voltage	0		0.8	V
	Voltage at any bus terminal V_A , V_B , V_Y or V_Z	-1.4		3.8	V
$ V_{ID} $	Magnitude of differential input voltage			V_{CC}	V
R_L	Differential load resistance	30	50		Ω
$1/t_{UI}$	Signaling rate			200	Mbps
T_A	Operating free-air temperature in RUM package	-40		125	°C

6.4 Thermal Information

THERMAL METRIC ⁽¹⁾		SN65MLVD203B	UNIT
		RUM (WQFN)	
		16 PINS	
R _{θJA}	Junction-to-ambient thermal resistance	39.0	°C/W
R _{θJC(top)}	Junction-to-case (top) thermal resistance	34.7	
R _{θJB}	Junction-to-board thermal resistance	17.7	
ψ _{JT}	Junction-to-top characterization parameter	0.6	
ψ _{JB}	Junction-to-board characterization parameter	17.7	
R _{θJC(bot)}	Junction-to-case (bottom) thermal resistance	7.5	

(1) For more information about traditional and new thermal metrics, see the [Semiconductor and IC Package Thermal Metrics](#) application report.

6.5 Electrical Characteristics

over recommended operating conditions (unless otherwise noted)⁽¹⁾

PARAMETER		TEST CONDITIONS	MIN	TYP	MAX	UNIT	
I _{CC}	Supply current	Driver only	R \bar{E} and DE at V _{CC} , R _L = 50 Ω, All others open		13	22	mA
		Both disabled	R \bar{E} at V _{CC} , DE at 0 V, R _L = No Load, All others open		1	4	
		Both enabled	R \bar{E} at 0 V, DE at V _{CC} , R _L = 50 Ω, All others open		16	24	
		Receiver only	R \bar{E} at 0 V, DE at 0 V, All others open		4	13	
P _D	Device power dissipation	R _L = 50 Ω, Input to D is a 50-MHz 50% duty cycle square wave, DE = high, RE = low, T _A = 85°C			100	mW	

(1) All typical values are at 25°C and with a 3.3-V supply voltage.

6.6 Electrical Characteristics – Driver

over recommended operating conditions unless otherwise noted

PARAMETER		TEST CONDITIONS	MIN ⁽¹⁾	TYP ⁽²⁾	MAX	UNIT
V _{YZ}	Differential output voltage magnitude ⁽⁴⁾	See Figure 7-2	480		650	mV
Δ V _{YZ}	Change in differential output voltage magnitude between logic states		-50		50	mV
V _{OS(SS)}	Steady-state common-mode output voltage	See Figure 7-3	0.8		1.2	V
ΔV _{OS(SS)}	Change in steady-state common-mode output voltage between logic states		-50		50	mV
V _{OS(PP)}	Peak-to-peak common-mode output voltage				150	mV
V _{Y(OC)}	Maximum steady-state open-circuit output voltage	See Figure 7-7	0		2.4	V
V _{Z(OC)}	Maximum steady-state open-circuit output voltage		0		2.4	V
V _{P(H)}	Voltage overshoot, low-to-high level output	See Figure 7-5			1.2 V _{SS}	V
V _{P(L)}	Voltage overshoot, high-to-low level output				-0.2 V _{SS}	V
I _{IH}	High-level input current (D, DE)	V _{IH} = 2 V to V _{CC}	0		10	μA
I _{IL}	Low-level input current (D, DE)	V _{IL} = GND to 0.8 V	-1		10	μA
I _{OS}	Differential short-circuit output current magnitude	See Figure 7-4			24	mA
I _{OZ}	High-impedance state output current (driver only)	-1.4 V ≤ (V _Y or V _Z) ≤ 3.8 V, Other output = 1.2 V	-15		10	μA
I _{O(OFF)}	Power-off output current	-1.4 V ≤ (V _Y or V _Z) ≤ 3.8 V, Other output = 1.2 V, 0 V ≤ V _{CC} ≤ 1.5 V	-10		10	μA
C _Y or C _Z	Output capacitance	V _I = 0.4 sin(30E6πt) + 0.5 V, ⁽³⁾ Other input at 1.2 V, driver disabled			6	pF

over recommended operating conditions unless otherwise noted

PARAMETER		TEST CONDITIONS	MIN ⁽¹⁾	TYP ⁽²⁾	MAX	UNIT
C _{YZ}	Differential output capacitance	V _{AB} = 0.4 sin(30E6πt) V, ⁽³⁾ Driver disabled		4.5		pF
C _{Y/Z}	Output capacitance balance, (C _Y /C _Z)		0.98		1.02	

- (1) The algebraic convention in which the least positive (most negative) limit is designated as minimum is used in this data sheet.
- (2) All typical values are at 25°C and with a 3.3-V supply voltage.
- (3) HP4194A impedance analyzer (or equivalent)
- (4) Measurement equipment accuracy is 10 mV at –40°C

6.7 Electrical Characteristics – Receiver

over recommended operating conditions unless otherwise noted

PARAMETER			TEST CONDITIONS	MIN	TYP ⁽¹⁾	MAX	UNIT
V _{IT+}	Positive-going differential input voltage threshold ⁽²⁾	Type 1	See Figure 7-9 and Table 7-1			50	mV
V _{IT-}	Negative-going differential input voltage threshold ⁽²⁾	Type 1			-50		mV
V _{HYS}	Differential input voltage hysteresis, (V _{IT+} – V _{IT-})	Type 1			25		mV
V _{OH}	High-level output voltage (R)		I _{OH} = -8 mA	2.4			V
V _{OL}	Low-level output voltage (R)		I _{OL} = 8 mA			0.4	V
I _{IH}	High-level input current (RE)		V _{IH} = 2 V to V _{CC}	-10		1	μA
I _{IL}	Low-level input current (RE)		V _{IL} = GND to 0.8 V	-10		0	μA
I _{OZ}	High-impedance output current (R)		V _O = 0 V or 3.6 V	-10		15	μA
C _A or C _B	Input capacitance		V _I = 0.4 sin(30E6πt) + 0.5 V ⁽³⁾ , Other input at 1.2 V		6		pF
C _{AB}	Differential input capacitance		V _{AB} = 0.4 sin(30E6πt) V ⁽³⁾		4.5		pF
C _{A/B}	Input capacitance balance, (C _A /C _B)			0.94		1.06	

- (1) All typical values are at 25°C and with a 3.3-V supply voltage.
(2) Measurement equipment accuracy is 10 mV at -40°C
(3) HP4194A impedance analyzer (or equivalent)

6.8 Switching Characteristics – Driver

over recommended operating conditions unless otherwise noted

PARAMETER		TEST CONDITIONS	MIN	TYP ⁽¹⁾	MAX	UNIT
t _{pLH}	Propagation delay time, low-to-high-level output	See Figure 7-5	2	2.5	3.5	ns
t _{pHL}	Propagation delay time, high-to-low-level output		2	2.5	3.5	ns
t _r	Differential output signal rise time		2.0			ns
t _f	Differential output signal fall time		2.0			ns
t _{sk(pp)}	Part-to-part skew ⁽²⁾				0.9	ns
t _{jit(per)}	Period jitter, rms (1 standard deviation) ⁽³⁾	62.5-MHz clock input ⁽⁴⁾			5	ps
t _{jit(per)}	Period jitter, rms (1 standard deviation) ⁽³⁾	100-MHz clock input ⁽⁴⁾			2	ps
t _{jit(pp)}	Peak-to-peak jitter ^{(3) (6)}	125 Mbps 8b10b input ⁽⁵⁾			250	ps
t _{jit(pp)}	Peak-to-peak jitter ^{(3) (6)}	200 Mbps 8b10b input ⁽⁵⁾			325	ps
t _{jit(pp)}	Peak-to-peak jitter ^{(3) (6)}	200 Mbps 2 ¹⁵ – 1 PRBS input ⁽⁵⁾			325	ps
t _{PHZ}	Disable time, high-level-to-high-impedance output	See Figure 7-6		5	7	ns
t _{PLZ}	Disable time, low-level-to-high-impedance output			5	7	ns
t _{PZH}	Enable time, high-impedance-to-high-level output			4	7	ns
t _{PZL}	Enable time, high-impedance-to-low-level output			4	7	ns

- (1) All typical values are at 25°C and with a 3.3-V supply voltage.
(2) Part-to-part skew is defined as the difference in propagation delays between two devices that operate at the same V/T conditions.
(3) Jitter is ensured by design and characterization. Stimulus jitter has been subtracted from the numbers.
(4) t_r = t_f = 0.5 ns (10% to 90%), measured over 30K samples.
(5) t_r = t_f = 0.5 ns (10% to 90%), measured over 100K samples.
(6) Peak-to-peak jitter includes jitter due to pulse skew (t_{sk(p)}).

6.9 Switching Characteristics – Receiver

over recommended operating conditions unless otherwise noted

PARAMETER		TEST CONDITIONS	MIN	TYP ⁽¹⁾	MAX	UNIT
t_{PLH}	Propagation delay time, low-to-high-level output	$C_L = 15 \text{ pF}$, See Figure 7-10	2	6	10	ns
t_{PHL}	Propagation delay time, high-to-low-level output		2	6	10	ns
t_r	Output signal rise time				2.3	ns
t_f	Output signal fall time				2.3	ns
$t_{sk(p)}$	Pulse skew ($t_{pHL} - t_{pLH}$)	Type 1 $C_L = 15 \text{ pF}$, See Figure 7-10		80	600	ps
$t_{sk(pp)}$	Part-to-part skew ⁽²⁾	$C_L = 15 \text{ pF}$, See Figure 7-10			1	ns
$t_{jit(per)}$	Period jitter, rms (1 standard deviation) ⁽³⁾	62.5-MHz clock input ⁽⁴⁾			5	ps
$t_{jit(per)}$	Period jitter, rms (1 standard deviation) ⁽³⁾	100-MHz clock input ⁽⁴⁾			3	ps
$t_{jit(pp)}$	Peak-to-peak jitter ^{(3) (6)}	Type 1 125 Mbps 8b10b input ⁽⁵⁾			130	ps
$t_{jit(pp)}$	Peak-to-peak jitter ^{(3) (6)}	Type 1 200 Mbps 8b10b input ⁽⁵⁾			250	ps
$t_{jit(pp)}$	Peak-to-peak jitter ^{(3) (6)}	Type 1 200 Mbps 2 ¹⁵ -1 PRBS input ⁽⁵⁾			300	ps
t_{PHZ}	Disable time, high-level-to-high-impedance output	See Figure 7-11		6	10	ns
t_{PLZ}	Disable time, low-level-to-high-impedance output			6	10	ns
t_{PZH}	Enable time, high-impedance-to-high-level output			10	15	ns
t_{PZL}	Enable time, high-impedance-to-low-level output			10	15	ns

(1) All typical values are at 25°C and with a 3.3-V supply voltage.

(2) Part-to-part skew is defined as the difference in propagation delays between two devices that operate at the same V/T conditions.

(3) Jitter is ensured by design and characterization. Stimulus jitter has been subtracted from the numbers.

(4) $V_{ID} = 200 \text{ mV}_{pp}$, $V_{cm} = 1 \text{ V}$, $t_r = t_f = 0.5 \text{ ns}$ (10% to 90%), measured over 30K samples.

(5) $V_{ID} = 200 \text{ mV}_{pp}$, $V_{cm} = 1 \text{ V}$, $t_r = t_f = 0.5 \text{ ns}$ (10% to 90%), measured over 100K samples.

(6) Peak-to-peak jitter includes jitter due to pulse skew ($t_{sk(p)}$)

6.10 Typical Characteristics

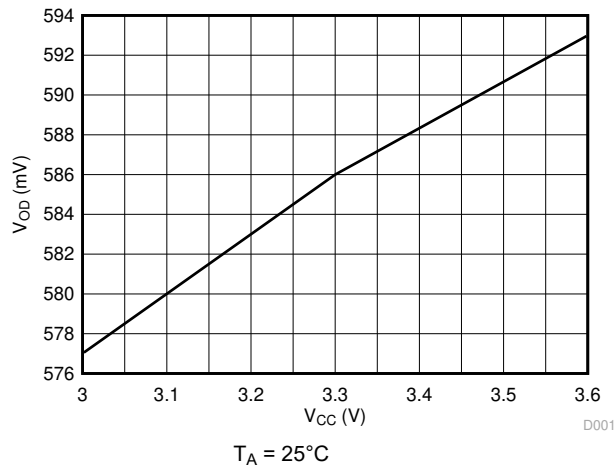

Figure 6-1. Differential Output Voltage vs Supply Voltage

7 Parameter Measurement Information

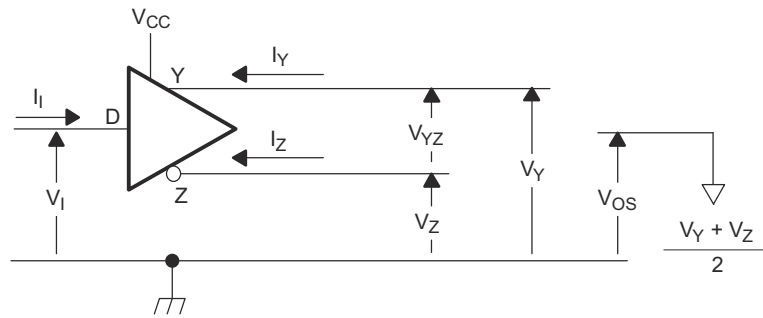
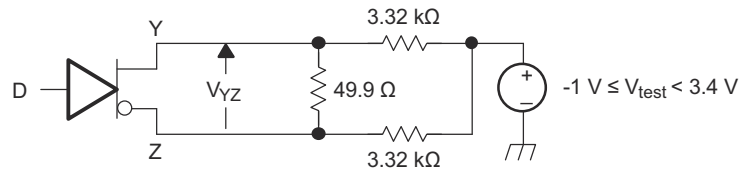
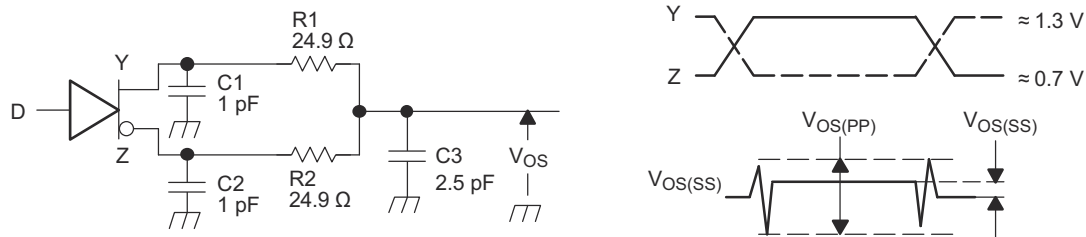

Figure 7-1. Driver Voltage and Current Definitions



- A. All resistors are 1% tolerance.

Figure 7-2. Differential Output Voltage Test Circuit



- A. All input pulses are supplied by a generator having the following characteristics: t_r or $t_f \leq 1$ ns, pulse frequency = 1 MHz, duty cycle = 50 \pm 5%.
- B. C1, C2 and C3 include instrumentation and fixture capacitance within 2 cm of the D.U.T. and are $\pm 20\%$.
- C. R1 and R2 are metal film, surface mount, $\pm 1\%$, and located within 2 cm of the D.U.T.
- D. The measurement of $V_{OS(PP)}$ is made on test equipment with a -3 dB bandwidth of at least 1 GHz.

Figure 7-3. Test Circuit and Definitions for the Driver Common-Mode Output Voltage

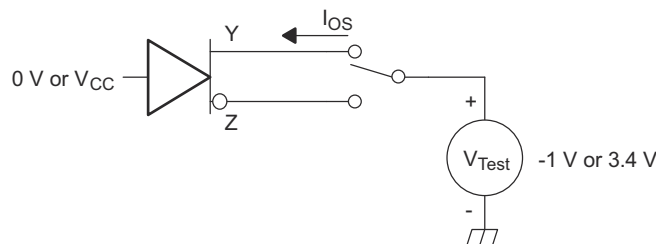
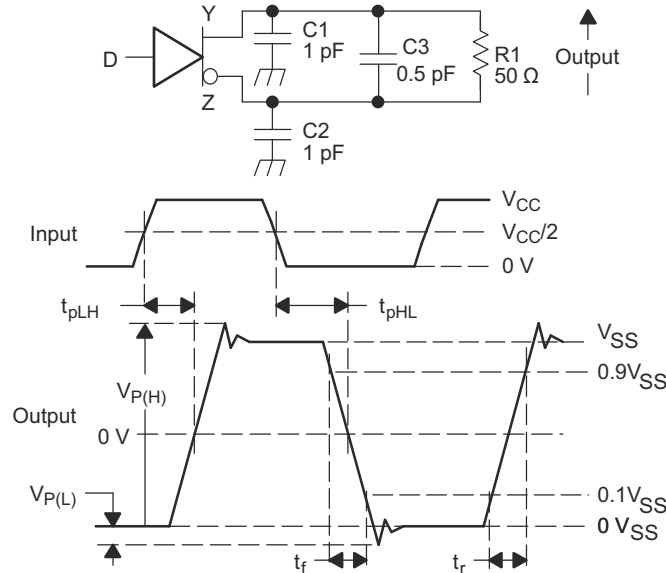
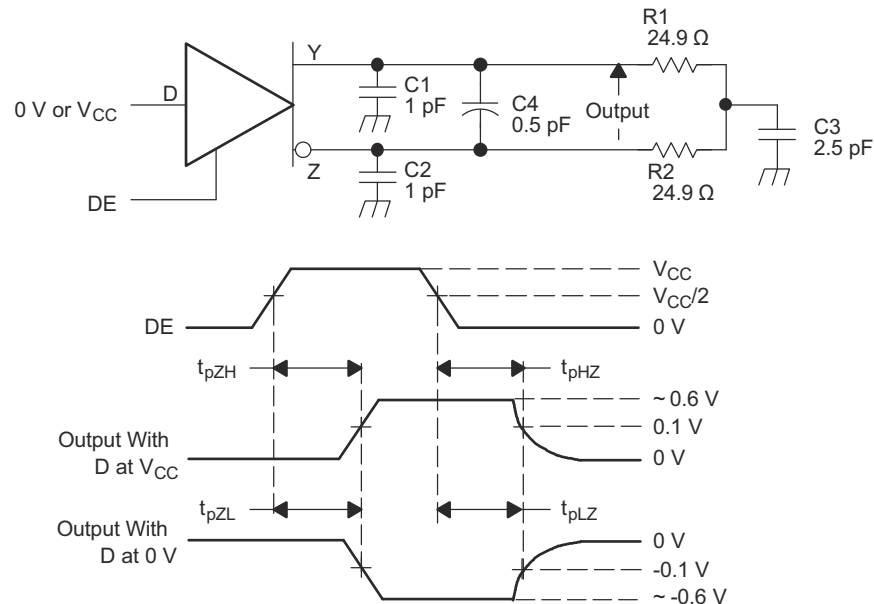

Figure 7-4. Driver Short-Circuit Test Circuit



- A. All input pulses are supplied by a generator having the following characteristics: t_r or $t_f \leq 1$ ns, frequency = 1 MHz, duty cycle = $50 \pm 5\%$.
- B. C1, C2, and C3 include instrumentation and fixture capacitance within 2 cm of the D.U.T. and are $\pm 20\%$.
- C. R1 is a metal film, surface mount, and 1% tolerance and located within 2 cm of the D.U.T.
- D. The measurement is made on test equipment with a -3 dB bandwidth of at least 1 GHz.

Figure 7-5. Driver Test Circuit, Timing, and Voltage Definitions for the Differential Output Signal



- A. All input pulses are supplied by a generator having the following characteristics: t_r or $t_f \leq 1$ ns, frequency = 1 MHz, duty cycle = $50 \pm 5\%$.
- B. C1, C2, C3, and C4 includes instrumentation and fixture capacitance within 2 cm of the D.U.T. and are $\pm 20\%$.
- C. R1 and R2 are metal film, surface mount, and 1% tolerance and located within 2 cm of the D.U.T.
- D. The measurement is made on test equipment with a -3 dB bandwidth of at least 1 GHz.

Figure 7-6. Driver Enable and Disable Time Circuit and Definitions

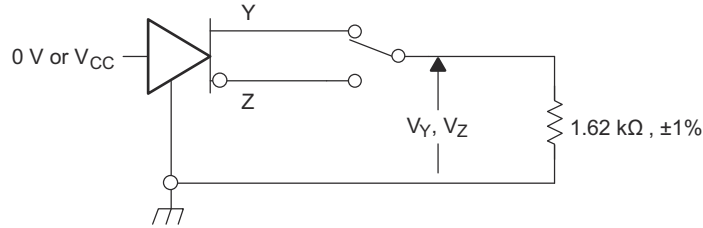
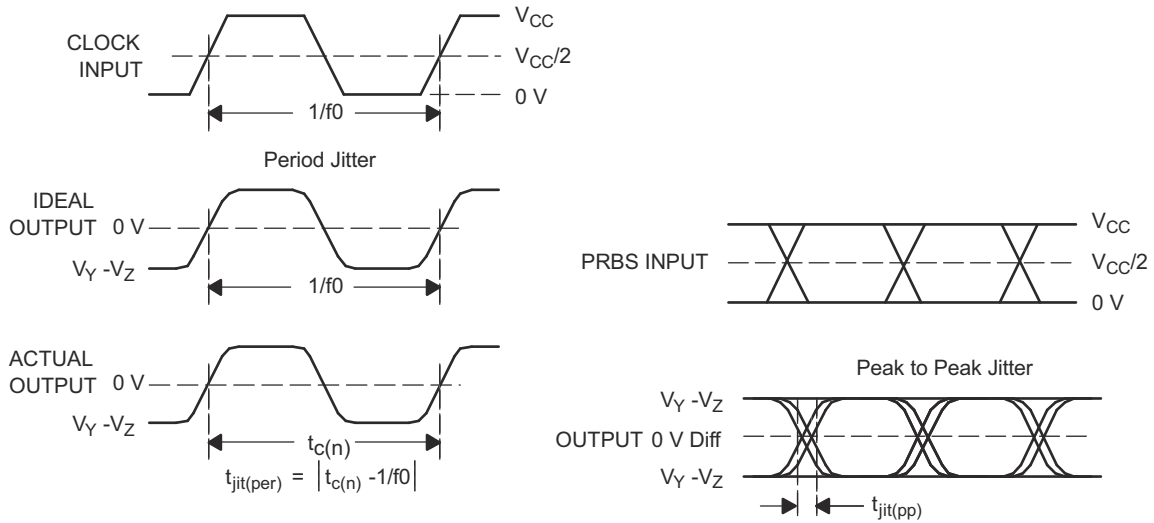
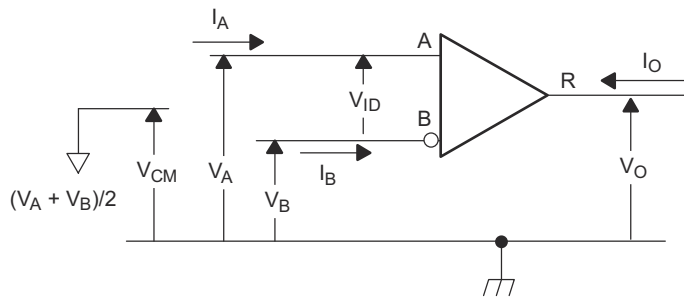

Figure 7-7. Maximum Steady State Output Voltage



- A. All input pulses are supplied by an Agilent 81250 Stimulus System.
- B. The measurement is made on a TEK TDS6604 running TDSJIT3 application software
- C. Period jitter is measured using a 100 MHz 50 ±1% duty cycle clock input.
- D. Peak-to-peak jitter is measured using a 200 Mbps $2^{15}-1$ PRBS input.

Figure 7-8. Driver Jitter Measurement Waveforms



Copyright © 2016, Texas Instruments Incorporated

Figure 7-9. Receiver Voltage and Current Definitions

Table 7-1. Type-1 Receiver Input Threshold Test Voltages

APPLIED VOLTAGES		RESULTING DIFFERENTIAL INPUT VOLTAGE	RESULTING COMMON-MODE INPUT VOLTAGE	RECEIVER OUTPUT
V_{IA}	V_{IB}	V_{ID}	V_{IC}	
2.400	0.000	2.400	1.200	H
0.000	2.400	-2.400	1.200	L
3.425	3.375	0.050	3.4	H
3.375	3.425	-0.050	3.4	L
-0.975	-1.025	0.050	-1	H
-1.025	-0.975	-0.050	-1	L

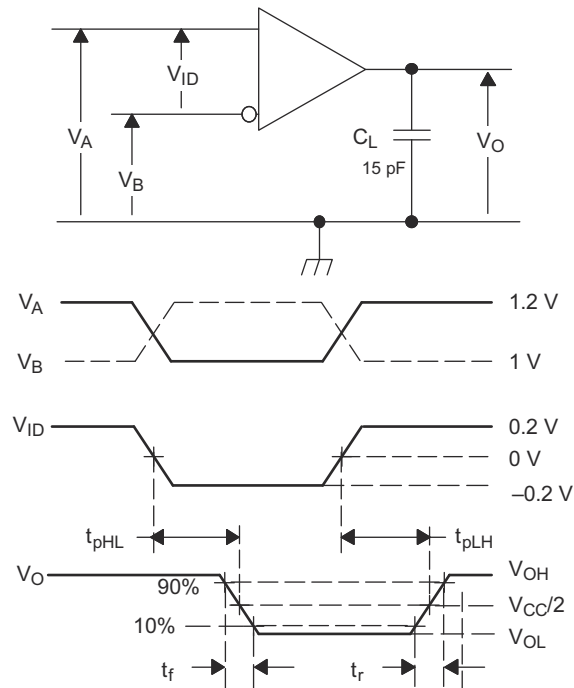

- A. All input pulses are supplied by a generator having the following characteristics: t_r or $t_f \leq 1$ ns, frequency = 1 MHz, duty cycle = $50 \pm 5\%$. C_L is a combination of a 20%-tolerance, low-loss ceramic, surface-mount capacitor and fixture capacitance within 2 cm of the D.U.T.
- B. The measurement is made on test equipment with a -3 dB bandwidth of at least 1 GHz.

Figure 7-10. Receiver Timing Test Circuit and Waveforms

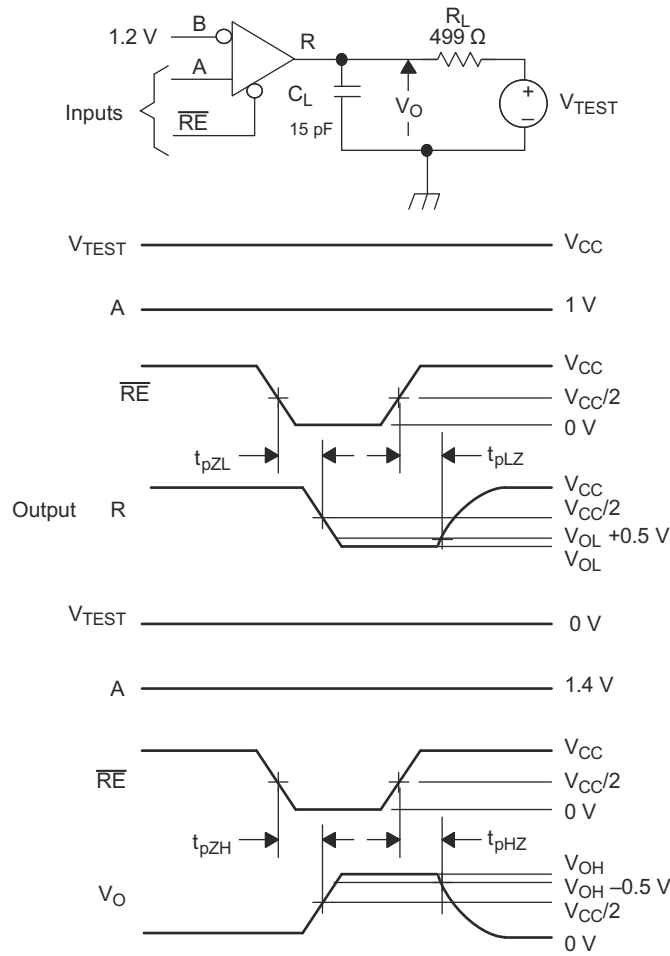

- All input pulses are supplied by a generator having the following characteristics: t_r or $t_f \leq 1$ ns, frequency = 1 MHz, duty cycle = $50 \pm 5\%$.
- R_L is 1% tolerance, metal film, surface mount, and located within 2 cm of the D.U.T.
- C_L is the instrumentation and fixture capacitance within 2 cm of the DUT and $\pm 20\%$.

Figure 7-11. Receiver Enable and Disable Time Test Circuit and Waveforms

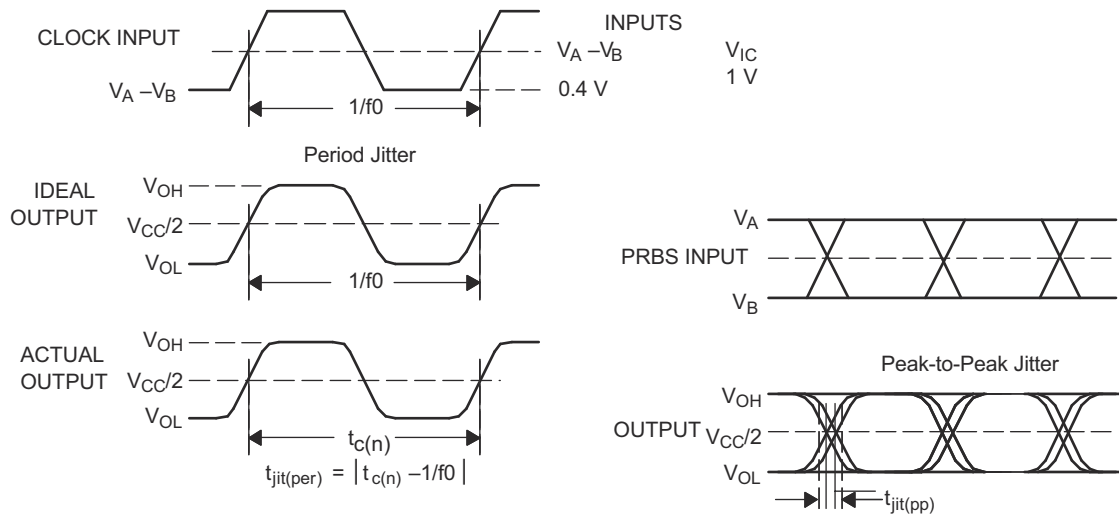

- All input pulses are supplied by an Agilent 8304A Stimulus System.
- The measurement is made on a TEK TDS6604 running TDSJIT3 application software
- Period jitter is measured using a 10 MHz 50 \pm 1% duty cycle clock input.
- Peak-to-peak jitter is measured using a 200 Mbps 2^{15} -1 PRBS input.

Figure 7-12. Receiver Jitter Measurement Waveforms

8 Detailed Description

8.1 Overview

The SN65MLVD203B is a multipoint-low-voltage differential (M-LVDS) line driver and receiver, which is optimized to operate at signaling rates up to 200 Mbps. The device complies with the multipoint low-voltage differential signaling (M-LVDS) standard TIA/EIA-899. This circuit is similar to the TIA/EIA-644 standard compliant LVDS counterpart, with added features to address multipoint applications. The driver output has been designed to support multipoint buses presenting loads as low as 30 Ω, and incorporates controlled transition times to allow for stubs off of the backbone transmission line.

The SN65MLVD203B has a Type-1 receiver that exhibits 25 mV of differential input voltage hysteresis to prevent output oscillations with slowly changing signals or loss of input.

8.2 Functional Block Diagrams

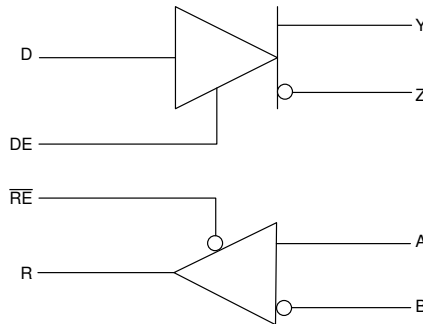

8.3 Feature Description

8.3.1 Power-On-Reset

The SN65MLVD203B operates and meets all the specified performance requirements for supply voltages in the range of 3 V to 3.6 V. When the supply voltage drops below 1.5 V (or is turning on and has not yet reached 1.5 V), power-on reset circuitry sets the driver output to a high-impedance state.

8.3.2 ESD Protection

The bus terminals of the SN65MLVD203B possess on-chip ESD protection against ±8-kV human body model (HBM) and ±8-kV IEC61000-4-2 contact discharge. The IEC-ESD test is far more severe than the HBM-ESD test. The 50% higher charge capacitance, C_s , and 78% lower discharge resistance, R_D of the IEC model produce significantly higher discharge currents than the HBM-model.

As stated in the IEC 61000-4-2 standard, contact discharge is the preferred test method; although IEC air-gap testing is less repeatable than contact testing, air discharge protection levels are inferred from the contact discharge test results.

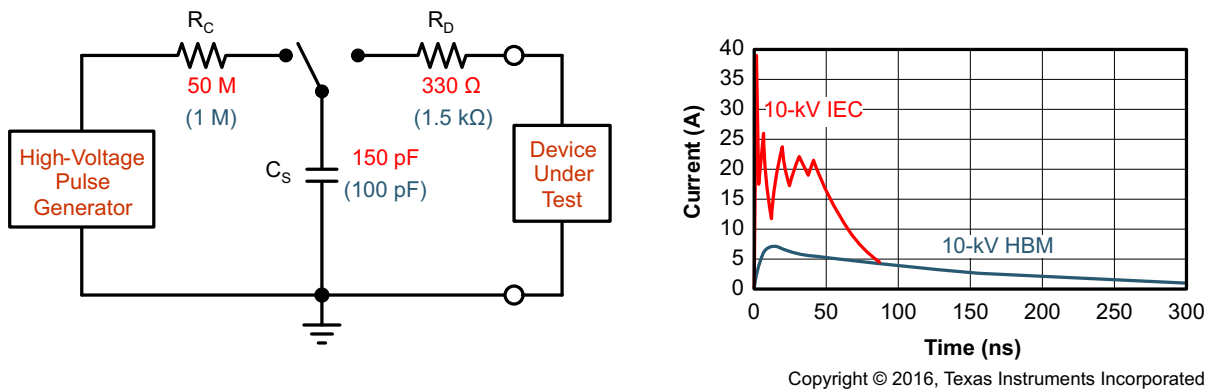

Figure 8-1. HBM and IEC-ESD Models and Currents in Comparison (HBM Values in Parenthesis)

8.3.3 RX Maximum Jitter While DE Toggling

Due to the internal circuitry of the Receiver and Driver Enable/Disable (DE), toggling the DE pin disrupts the biasing of the receiver and results in a current change. This current change adds jitter to the receiver. If the DE pin is toggled, the maximum peak-to-peak jitter of the receiver is estimated to be 2.1 ns.

8.4 Device Functional Modes

8.4.1 Operation with $V_{CC} < 1.5\text{ V}$

Bus pins are high impedance under this condition.

8.4.2 Operations with $1.5\text{ V} \leq V_{CC} < 3\text{ V}$

Operation with supply voltages in the range of $1.5\text{ V} \leq V_{CC} < 3\text{ V}$ is undefined and no specific device performance is guaranteed in this range.

8.4.3 Operation with $3\text{ V} \leq V_{CC} < 3.6\text{ V}$

Operation with the supply voltages greater than or equal to 3 V and less than or equal to 3.6 V is normal operation.

8.4.4 Device Function Tables

Table 8-1. Type-1 Receiver

INPUTS		OUTPUT
$V_{ID} = V_A - V_B$	\overline{RE}	R
$V_{ID} \geq 50\text{ mV}$	L	H
$-50\text{ mV} < V_{ID} < 50\text{ mV}$	L	?
$V_{ID} \leq -50\text{ mV}$	L	L
X	H	Z
X	Open	Z

Table 8-2. Driver

INPUTS	ENABLE	OUTPUTS	
		X	Y
D	DE		
L	H	L	H
H	H	H	L
Open	H	L	H
X	Open	Z	Z
X	L	Z	Z

8.4.5 Equivalent Input and Output Schematic Diagrams

DRIVER INPUT AND DRIVER ENABLE

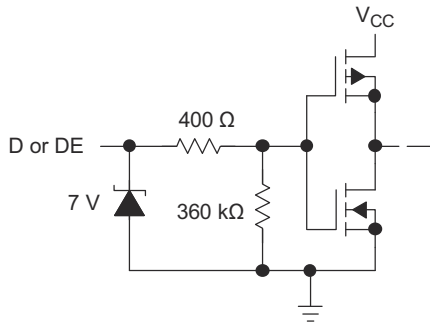

DRIVER OUTPUT

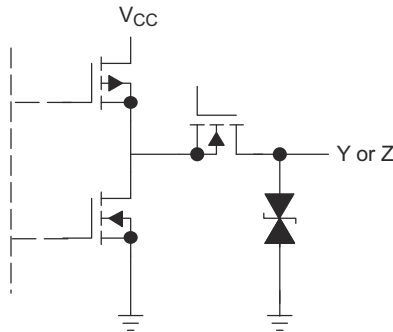

RECEIVER ENABLE

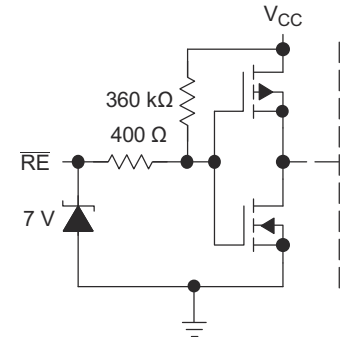

RECEIVER INPUT

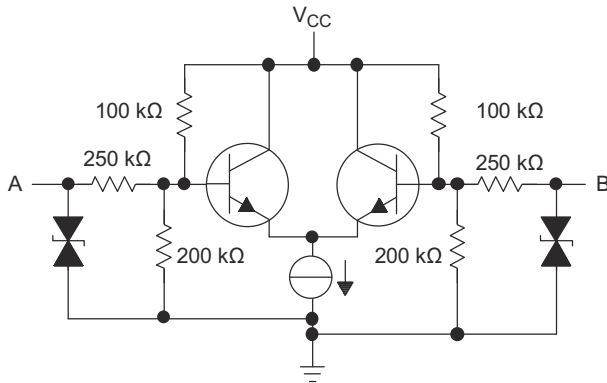

RECEIVER OUTPUT

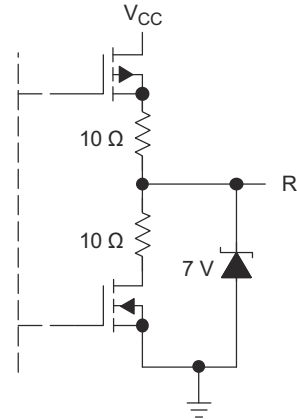

9 Application and Implementation

Note

Information in the following applications sections is not part of the TI component specification, and TI does not warrant its accuracy or completeness. TI's customers are responsible for determining suitability of components for their purposes, as well as validating and testing their design implementation to confirm system functionality.

9.1 Application Information

The SN65MLVD203B is a multipoint line driver and receiver. The functionality of the device is simple, yet extremely flexible, leading to their use in designs ranging from wireless base stations to desktop computers.

9.2 Typical Application

9.2.1 Multipoint Communications

In a multipoint configuration many transmitters and many receivers can be interconnected on a single transmission line. The key difference compared to multi-drop is the presence of two or more drivers. Such a situation creates contention issues that need not be addressed with point-to-point or multidrop systems. Multipoint operation allows for bidirectional, half-duplex communication over a single balanced media pair. To support the location of the various drivers throughout the transmission line, double termination of the transmission line is now necessary.

The major challenge that system designers encounter are the impedance discontinuities that device loading and device connections (stubs) introduce on the common bus. Matching the impedance of the loaded bus and using signal drivers with controlled signal edges are the keys to error-free signal transmissions in multipoint topologies.

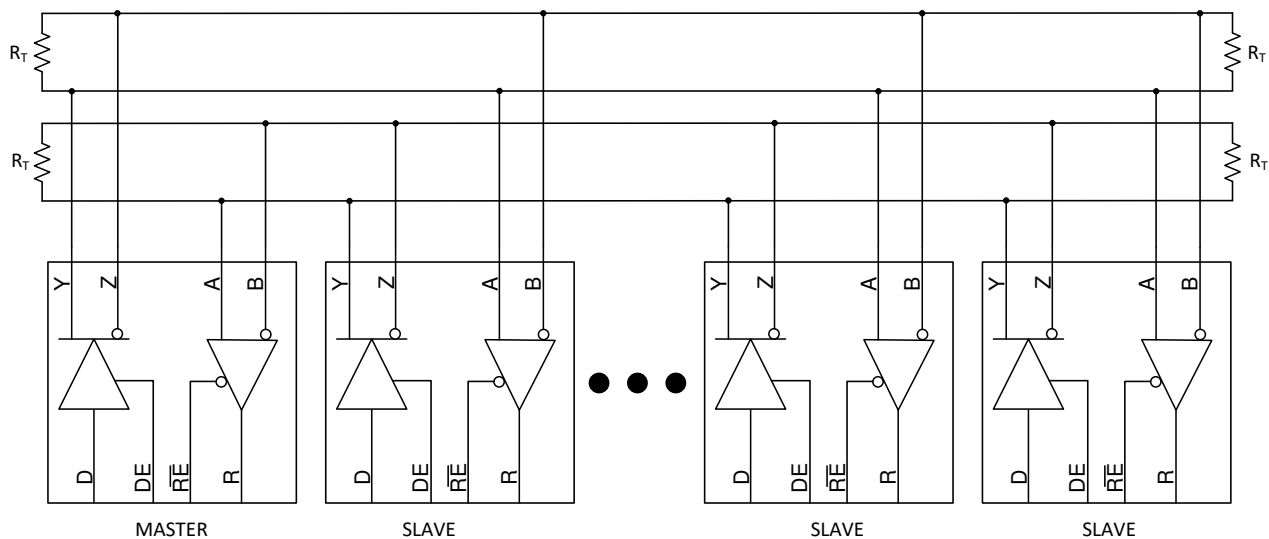

Figure 9-1. Multipoint Configuration

9.2.2 Design Requirements

For this design example, use the parameters listed in [Table 9-1](#).

Table 9-1. Design Parameters

PARAMETERS	VALUES
Driver supply voltage	3 to 3.6 V
Driver input voltage	0.8 to 3.3 V
Driver signaling rate	DC to 200 Mbps
Interconnect characteristic impedance	100 Ω
Termination resistance (differential)	100 Ω
Number of receiver nodes	2 to 32
Receiver supply voltage	3 to 3.6 V
Receiver input voltage	0 to (V _{CC} – 0.8) V
Receiver signaling rate	DC to 200 Mbps
Ground shift between driver and receiver	±1 V

9.2.3 Detailed Design Procedure

9.2.3.1 Supply Voltage

The SN65MLVD203B is operated from a single supply. The device can support operations with a supply as low as 3 V and as high as 3.6 V.

9.2.3.2 Supply Bypass Capacitance

Bypass capacitors play a key role in power distribution circuitry. At low frequencies, power supply offers very low-impedance paths between its terminals. However, as higher frequency currents propagate through power traces, the source is often incapable of maintaining a low-impedance path to ground. Bypass capacitors are used to address this shortcoming. Usually, large bypass capacitors (10 μF to 1000 μF) at the board level do a good job up into the kHz range. Due to their size and length of their leads, large capacitors tend to have large inductance values at the switching frequencies. To solve this problem, smaller capacitors (in the nF to μF range) must be installed locally next to the integrated circuit.

Multilayer ceramic chip or surface-mount capacitors (size 0603 or 0805) minimize lead inductances of bypass capacitors in high-speed environments, because their lead inductance is about 1 nH. For comparison purposes, a typical capacitor with leads has a lead inductance around 5 nH.

The value of the bypass capacitors used locally with M-LVDS chips can be determined by [Equation 1](#) and [Equation 2](#), according to *High Speed Digital Design – A Handbook of Black Magic* by Howard Johnson and Martin Graham (1993). A conservative rise time of 4 ns and a worst-case change in supply current of 100 mA covers the whole range of M-LVDS devices offered by Texas Instruments. In this example, the maximum power supply noise tolerated is 100 mV; however, this figure varies depending on the noise budget available for the design.

$$C_{\text{chip}} = \left(\frac{\Delta I_{\text{Maximum Step Change Supply Current}}}{\Delta V_{\text{Maximum Power Supply Noise}}} \right) \times T_{\text{Rise Time}} \quad (1)$$

$$C_{\text{MLVDS}} = \left(\frac{100 \text{ mA}}{100 \text{ mV}} \right) \times 4 \text{ ns} = 0.004 \text{ } \mu\text{F} \quad (2)$$

[Figure 9-2](#) shows a configuration that lowers lead inductance and covers intermediate frequencies between the board-level capacitor (>10 μF) and the value of capacitance found above (0.004 μF). Place the smallest value of capacitance as close as possible to the chip.

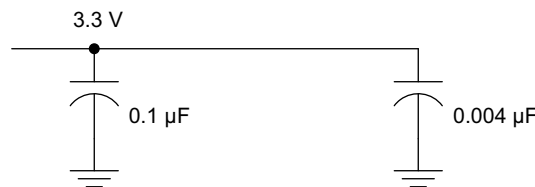

Figure 9-2. Recommended M-LVDS Bypass Capacitor Layout

9.2.3.3 Driver Input Voltage

The input stage accepts LVTTTL signals. The driver operates with a decision threshold of approximately 1.4 V.

9.2.3.4 Driver Output Voltage

The driver outputs a steady state common mode voltage of 1 V with a differential signal of 540 mV under nominal conditions.

9.2.3.5 Termination Resistors

As shown earlier, an M-LVDS communication channel employs a current source driving a transmission line which is terminated with two resistive loads. These loads serve to convert the transmitted current into a voltage at the receiver input. To ensure good signal integrity, the termination resistors should be matched to the characteristic impedance of the transmission line. The designer should ensure that the termination resistors are within 10% of the nominal media characteristic impedance. If the transmission line is targeted for 100-Ω impedance, the termination resistors should be between 90 Ω and 110 Ω. The line termination resistors are typically placed at the ends of the transmission line.

9.2.3.6 Receiver Input Signal

The M-LVDS receivers herein comply with the M-LVDS standard and correctly determine the bus state. These devices have Type-1 and Type-2 receivers that detect the bus state with as little as 50 mV of differential voltage over the common mode range of –1 V to 3.4 V.

9.2.3.7 Receiver Input Threshold (Failsafe)

The MLVDS standard defines a Type-1 and Type-2 receiver. Type-1 receivers have their differential input voltage thresholds near zero volts. Type-2 receivers have their differential input voltage thresholds offset from 0 V to detect the absence of a voltage difference. The impact to receiver output by the offset input can be seen in [Table 9-2](#) and [Figure 9-3](#).

Table 9-2. Receiver Input Voltage Threshold Requirements

RECEIVER TYPE	OUTPUT LOW	OUTPUT HIGH
Type 1	$-2.4 \text{ V} \leq V_{ID} \leq -0.05 \text{ V}$	$0.05 \text{ V} \leq V_{ID} \leq 2.4 \text{ V}$
Type 2	$-2.4 \text{ V} \leq V_{ID} \leq 0.05 \text{ V}$	$0.15 \text{ V} \leq V_{ID} \leq 2.4 \text{ V}$

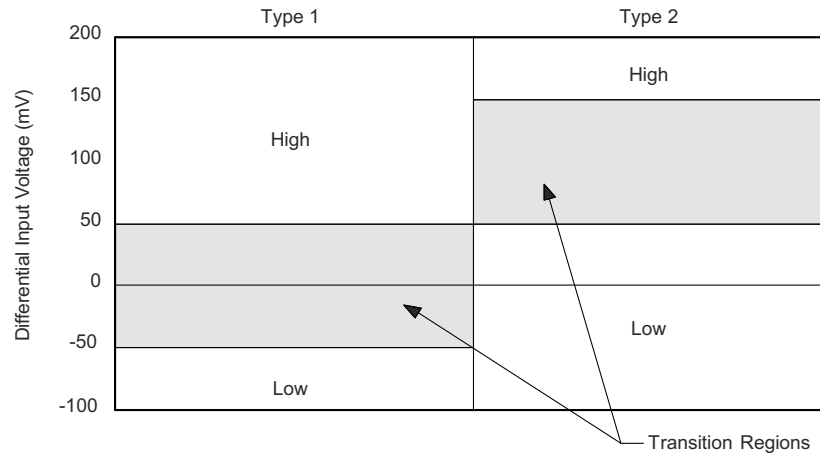

Figure 9-3. Expanded Graph of Receiver Differential Input Voltage Showing Transition Region

9.2.3.8 Receiver Output Signal

Receiver outputs comply with LVTTTL output voltage standards when the supply voltage is within the range of 3 V to 3.6 V.

9.2.3.9 Interconnecting Media

The physical communication channel between the driver and the receiver may be any balanced paired metal conductors meeting the requirements of the M-LVDS standard, the key points which will be included here. This media may be a twisted pair, twinax, flat ribbon cable, or PCB traces.

The nominal characteristic impedance of the interconnect should be between 100 Ω and 120 Ω with variation no more than 10% (90 Ω to 132 Ω).

9.2.3.10 PCB Transmission Lines

As per [SNLA187](#), [Figure 9-4](#) depicts several transmission line structures commonly used in printed-circuit boards (PCBs). Each structure consists of a signal line and a return path with uniform cross-section along its length. A microstrip is a signal trace on the top (or bottom) layer, separated by a dielectric layer from its return path in a ground or power plane. A stripline is a signal trace in the inner layer, with a dielectric layer in between a ground plane above and below the signal trace. The dimensions of the structure along with the dielectric material properties determine the characteristic impedance of the transmission line (also called controlled-impedance transmission line).

When two signal lines are placed close by, they form a pair of coupled transmission lines. [Figure 9-4](#) shows examples of edge-coupled microstrips, and edge-coupled or broad-side-coupled striplines. When excited by differential signals, the coupled transmission line is referred to as a differential pair. The characteristic impedance of each line is called odd-mode impedance. The sum of the odd-mode impedances of each line is the differential impedance of the differential pair. In addition to the trace dimensions and dielectric material properties, the spacing between the two traces determines the mutual coupling and impacts the differential impedance. When the two lines are immediately adjacent; for example, if S is less than $2 \times W$, the differential pair is called a tightly-coupled differential pair. To maintain constant differential impedance along the length, it is important to keep the trace width and spacing uniform along the length, as well as maintain good symmetry between the two lines.

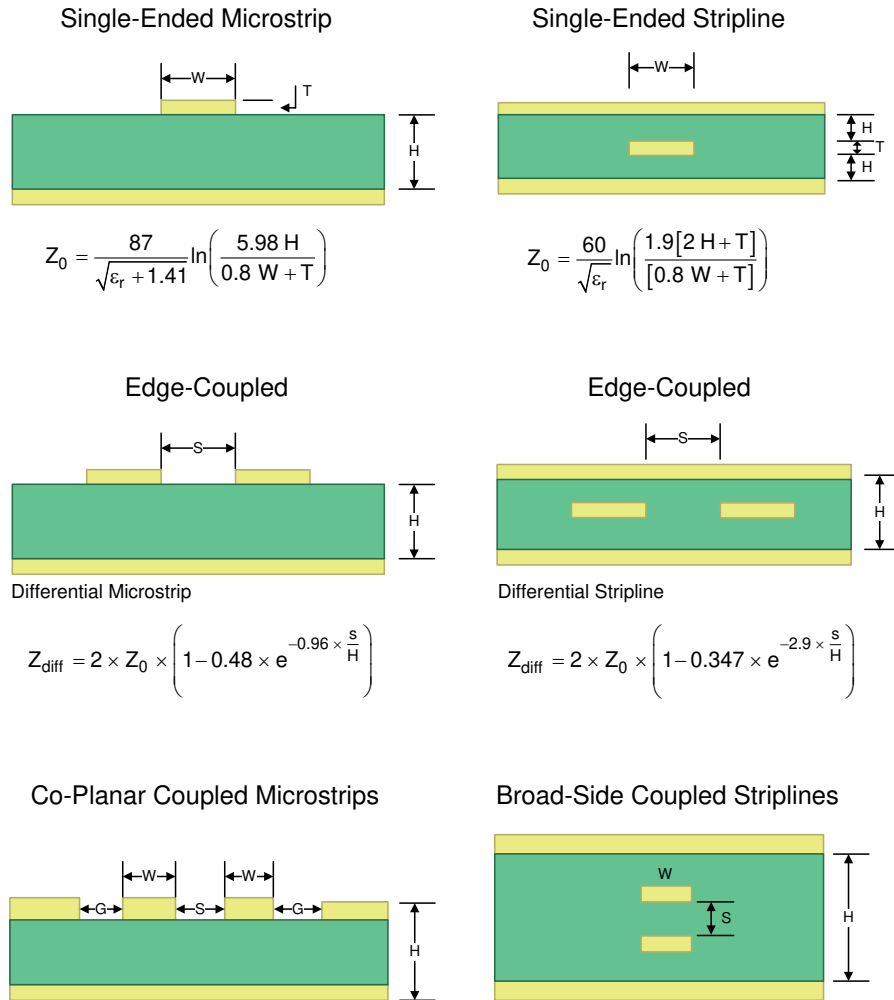
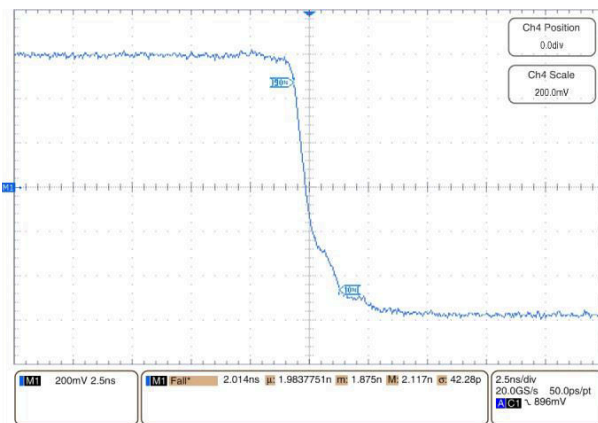

Figure 9-4. Controlled-Impedance Transmission Lines

9.2.4 Application Curves



V_{CC} = 3.3 V T_A = 25°C

Figure 9-5. Driver Fall Time

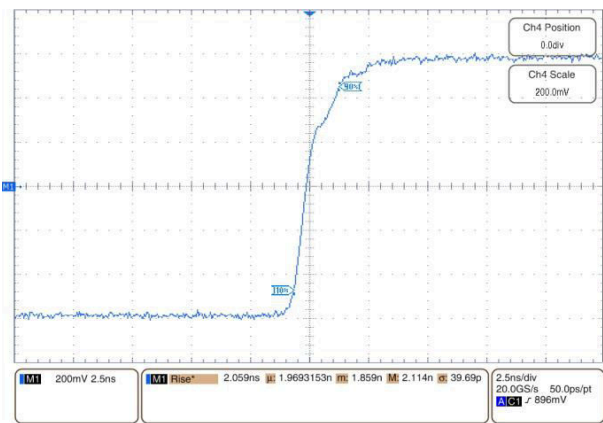

V_{CC} = 3.3 V T_A = 25°C

Figure 9-6. Driver Rise Time

9.3 Power Supply Recommendations

The M-LVDS driver and receivers in this data sheet are designed to operate from a single power supply. Both drivers and receivers operate with supply voltages in the range of 3 V to 3.6 V. In a typical application, a driver and a receiver may be on separate boards, or even separate equipment. In these cases, separate supplies would be used at each location. The expected ground potential difference between the driver power supply and the receiver power supply would be less than ± 1 V. Board level and local device level bypass capacitance should be used and are covered Supply Bypass Capacitance.

9.4 Layout

9.4.1 Layout Guidelines

9.4.1.1 Microstrip vs. Stripline Topologies

As per SLLD009, printed-circuit boards usually offer designers two transmission line options: Microstrip and stripline. Microstrips are traces on the outer layer of a PCB, as shown in Figure 9-7.

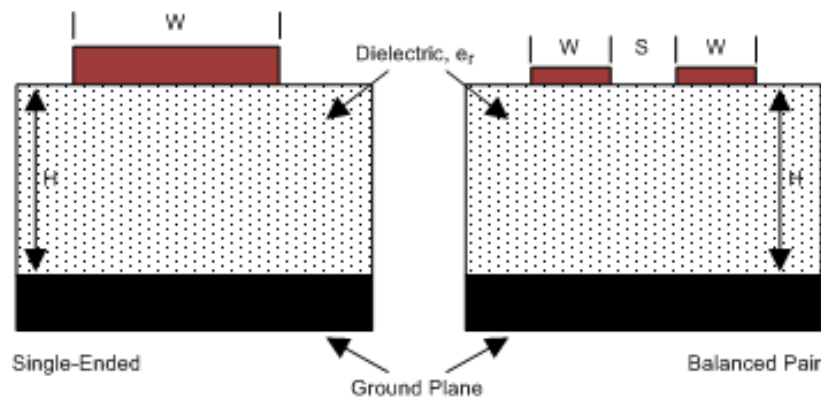

Figure 9-7. Microstrip Topology

On the other hand, striplines are traces between two ground planes. Striplines are less prone to emissions and susceptibility problems because the reference planes effectively shield the embedded traces. However, from the standpoint of high-speed transmission, juxtaposing two planes creates additional capacitance. TI recommends routing M-LVDS signals on microstrip transmission lines if possible. The PCB traces allow designers to specify the necessary tolerances for Z_0 based on the overall noise budget and reflection allowances. Footnotes ², ²³, and ³⁴ provide formulas for Z_0 and t_{PD} for differential and single-ended traces. ² ³ ⁴

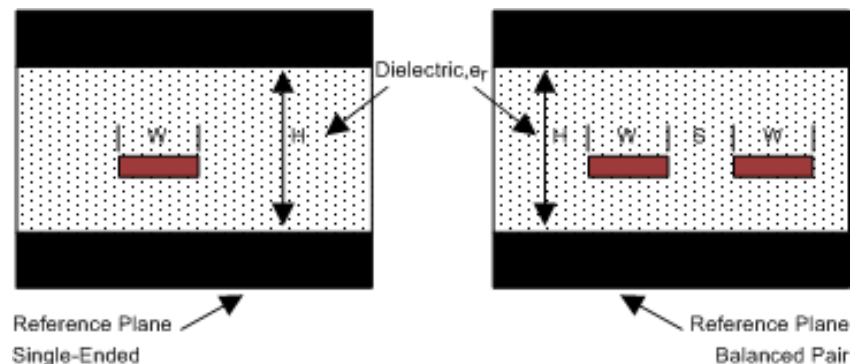

Figure 9-8. Stripline Topology

² Howard Johnson & Martin Graham. 1993. High Speed Digital Design – A Handbook of Black Magic. Prentice Hall PRT. ISBN number 013395724.

³ Mark I. Montrose. 1996. Printed Circuit Board Design Techniques for EMC Compliance. IEEE Press. ISBN number 0780311310.

⁴ Clyde F. Coombs, Jr. Ed, Printed Circuits Handbook, McGraw Hill, ISBN number 0070127549.

9.4.1.2 Dielectric Type and Board Construction

The speeds at which signals travel across the board dictates the choice of dielectric. FR-4, or equivalent, usually provides adequate performance for use with M-LVDS signals. If rise or fall times of TTL/CMOS signals are less than 500 ps, empirical results indicate that a material with a dielectric constant near 3.4, such as Rogers™ 4350 or Nelco N4000-13 is better suited. Once the designer chooses the dielectric, there are several parameters pertaining to the board construction that can affect performance. The following set of guidelines were developed experimentally through several designs involving M-LVDS devices:

- Copper weight: 15 g or 1/2 oz start, plated to 30 g or 1 oz
- All exposed circuitry should be solder-plated (60/40) to 7.62 μm or 0.0003 in (minimum).
- Copper plating should be 25.4 μm or 0.001 in (minimum) in plated-through-holes.
- Solder mask over bare copper with solder hot-air leveling

9.4.1.3 Recommended Stack Layout

Following the choice of dielectrics and design specifications, you must decide how many levels to use in the stack. To reduce the TTL/CMOS to M-LVDS crosstalk, it is a good practice to have at least two separate signal planes as shown in [Figure 9-9](#).

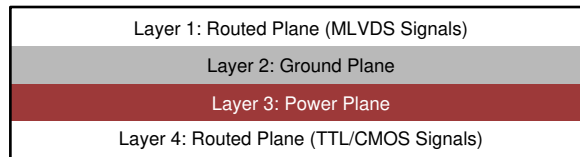

Figure 9-9. Four-Layer PCB Board

Note

The separation between layers 2 and 3 should be 127 μm (0.005 in). By keeping the power and ground planes tightly coupled, the increased capacitance acts as a bypass for transients.

One of the most common stack configurations is the six-layer board, as shown in [Figure 9-10](#).

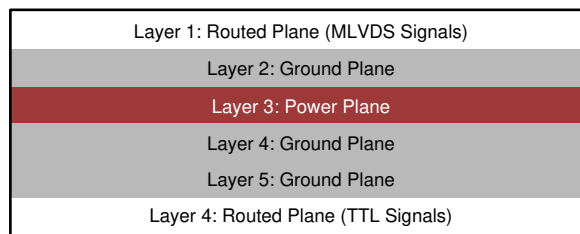

Figure 9-10. Six-Layer PCB Board

In this particular configuration, it is possible to isolate each signal layer from the power plane by at least one ground plane. The result is improved signal integrity; however, fabrication is more expensive. Using the 6-layer board is preferable, because it offers the layout designer more flexibility in varying the distance between signal layers and referenced planes, in addition to ensuring reference to a ground plane for signal layers 1 and 6.

9.4.1.4 Separation Between Traces

The separation between traces depends on several factors; however, the amount of coupling that can be tolerated usually dictates the actual separation. Low noise coupling requires close coupling between the differential pair of an M-LVDS link to benefit from the electromagnetic field cancellation. The traces should be 100-Ω differential and thus coupled in the manner that best fits this requirement. In addition, differential pairs should have the same electrical length to ensure that they are balanced, thus minimizing problems with skew and signal reflection.

In the case of two adjacent single-ended traces, one should use the 3-W rule, which stipulates that the distance between two traces must be greater than two times the width of a single trace, or three times its width measured from trace center to trace center. This increased separation effectively reduces the potential for crosstalk. The same rule should be applied to the separation between adjacent M-LVDS differential pairs, whether the traces are edge-coupled or broad-side-coupled.

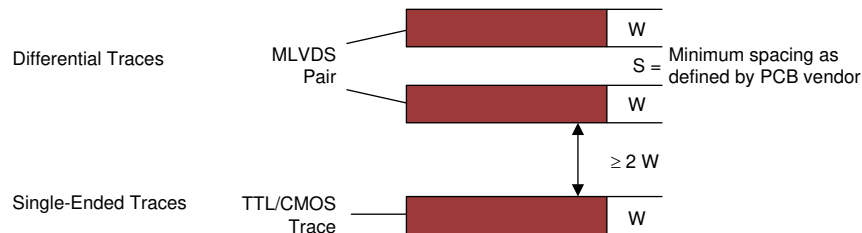

Figure 9-11. 3-W Rule for Single-Ended and Differential Traces (Top View)

You should exercise caution when using autorouters, because they do not always account for all factors affecting crosstalk and signal reflection. For instance, it is best to avoid sharp 90° turns to prevent discontinuities in the signal path. Using successive 45° turns tends to minimize reflections.

9.4.1.5 Crosstalk and Ground Bounce Minimization

To reduce crosstalk, it is important to provide a return path to high-frequency currents that is as close as possible to its originating trace. A ground plane usually achieves this. Because the returning currents always choose the path of lowest inductance, they are most likely to return directly under the original trace, thus minimizing crosstalk. Lowering the area of the current loop lowers the potential for crosstalk. Traces kept as short as possible with an uninterrupted ground plane running beneath them emit the minimum amount of electromagnetic field strength. Discontinuities in the ground plane increase the return path inductance and should be avoided.

9.4.1.6 Decoupling

Each power or ground lead of a high-speed device should be connected to the PCB through a low inductance path. For best results, one or more vias are used to connect a power or ground pin to the nearby plane. Ideally, via placement is immediately adjacent to the pin to avoid adding trace inductance. Placing a power plane closer to the top of the board reduces the effective via length and its associated inductance.

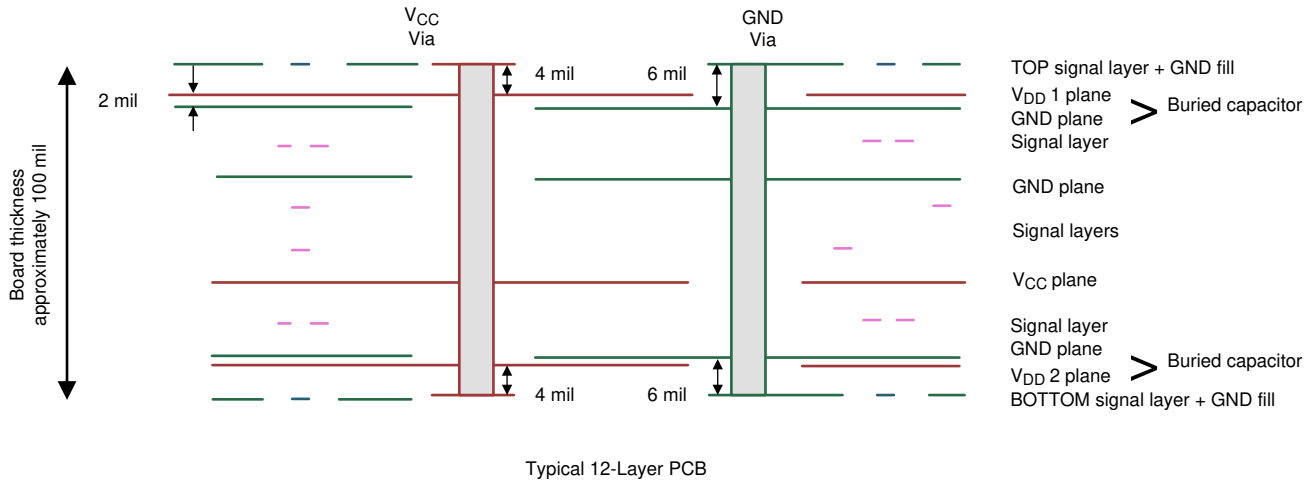
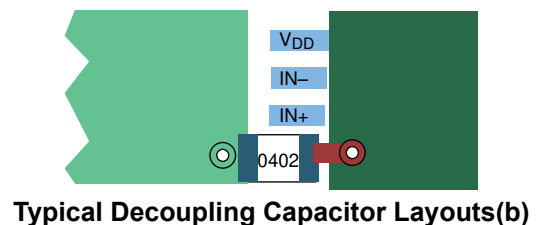
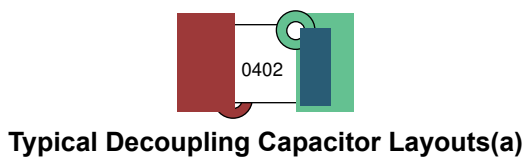

Figure 9-12. Low Inductance, High-Capacitance Power Connection

Bypass capacitors should be placed close to V_{DD} pins. They can be placed conveniently near the corners or underneath the package to minimize the loop area. This extends the useful frequency range of the added capacitance. Small-physical-size capacitors, such as 0402, 0201, or X7R surface-mount capacitors should be used to minimize body inductance of capacitors. Each bypass capacitor is connected to the power and ground plane through vias tangent to the pads of the capacitor as shown in Figure 9-13(a).

An X7R surface-mount capacitor of size 0402 has about 0.5 nH of body inductance. At frequencies above 30 MHz or so, X7R capacitors behave as low-impedance inductors. To extend the operating frequency range to a few hundred MHz, an array of different capacitor values like 100 pF, 1 nF, 0.03 μ F, and 0.1 μ F are commonly used in parallel. The most effective bypass capacitor can be built using sandwiched layers of power and ground at a separation of 2 to 3 mils. With a 2-mil FR4 dielectric, there is approximately 500 pF per square inch of PCB. Many high-speed devices provide a low-inductance GND connection on the backside of the package. This center pad must be connected to a ground plane through an array of vias. The via array reduces the effective inductance to ground and enhances the thermal performance of the small Surface Mount Technology (SMT) package. Placing vias around the perimeter of the pad connection ensures proper heat spreading and the lowest possible die temperature. Placing high-performance devices on opposing sides of the PCB using two GND planes (as shown in Figure 9-4) creates multiple paths for heat transfer. Often thermal PCB issues are the result of one device adding heat to another, resulting in a very high local temperature. Multiple paths for heat transfer minimize this possibility. In many cases the GND pad makes the optimal decoupling layout impossible to achieve due to insufficient pad-to-pad spacing as shown in Figure 9-13(b). When this occurs, placing the decoupling capacitor on the backside of the board keeps the extra inductance to a minimum. It is important to place the V_{DD} via as close to the device pin as possible while still allowing for sufficient solder mask coverage. If the via is left open, solder may flow from the pad and into the via barrel. This will result in a poor solder connection.



9.4.2 Layout Example

At least two or three times the width of an individual trace should separate single-ended traces and differential pairs to minimize the potential for crosstalk. Single-ended traces that run in parallel for less than the wavelength of the rise or fall times usually have negligible crosstalk. Increase the spacing between signal paths for long parallel runs to reduce crosstalk. Boards with limited real estate can benefit from the staggered trace layout, as shown in Figure 9-13.

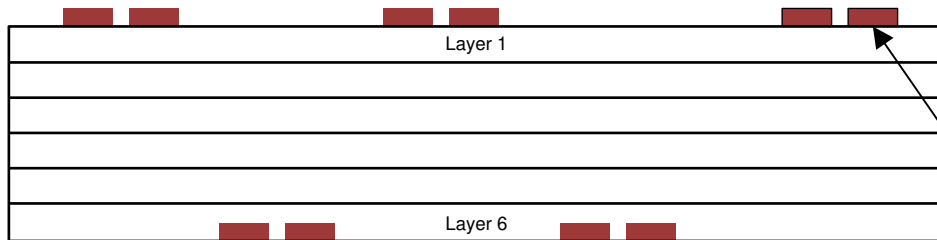

Figure 9-13. Staggered Trace Layout

This configuration lays out alternating signal traces on different layers; thus, the horizontal separation between traces can be less than 2 or 3 times the width of individual traces. To ensure continuity in the ground signal path, TI recommends having an adjacent ground via for every signal via, as shown in Figure 9-14. Note that vias create additional capacitance. For example, a typical via has a lumped capacitance effect of 1/2 pF to 1 pF in FR4.

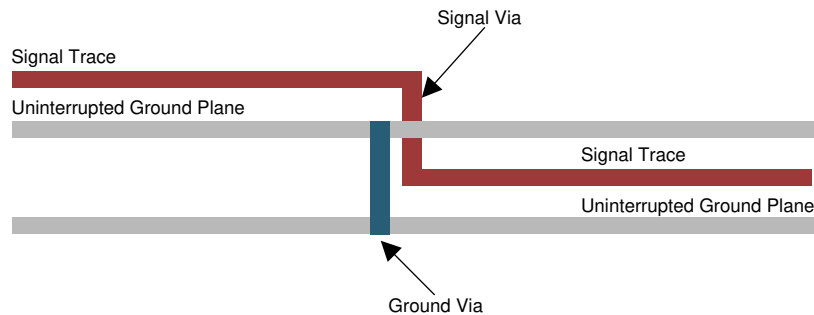

Figure 9-14. Ground Via Location (Side View)

Short and low-impedance connection of the device ground pins to the PCB ground plane reduces ground bounce. Holes and cutouts in the ground planes can adversely affect current return paths if they create discontinuities that increase returning current loop areas.

To minimize EMI problems, TI recommends avoiding discontinuities below a trace (for example, holes, slits, and so on) and keeping traces as short as possible. Zoning the board wisely by placing all similar functions in the same area, as opposed to mixing them together, helps reduce susceptibility issues.

10 Device and Documentation Support

10.1 Documentation Support

10.1.1 Related Documentation

For related documentation, see the following:

1. Howard Johnson & Martin Graham. 1993. High Speed Digital Design – A Handbook of Black Magic. Prentice Hall PRT. ISBN number 013395724.
2. Mark I. Montrose. 1996. Printed Circuit Board Design Techniques for EMC Compliance. IEEE Press. ISBN number 0780311310.
3. Clyde F. Coombs, Jr. Ed, Printed Circuits Handbook, McGraw Hill, ISBN number 0070127549.

10.2 Receiving Notification of Documentation Updates

To receive notification of documentation updates, navigate to the device product folder on ti.com. Click on *Subscribe to updates* to register and receive a weekly digest of any product information that has changed. For change details, review the revision history included in any revised document.

10.3 Support Resources

[TI E2E™ support forums](#) are an engineer's go-to source for fast, verified answers and design help — straight from the experts. Search existing answers or ask your own question to get the quick design help you need.

Linked content is provided "AS IS" by the respective contributors. They do not constitute TI specifications and do not necessarily reflect TI's views; see TI's [Terms of Use](#).

10.4 Trademarks

Rogers™ is a trademark of Rogers Corporation.

TI E2E™ is a trademark of Texas Instruments.

All trademarks are the property of their respective owners.

10.5 Electrostatic Discharge Caution



This integrated circuit can be damaged by ESD. Texas Instruments recommends that all integrated circuits be handled with appropriate precautions. Failure to observe proper handling and installation procedures can cause damage.

ESD damage can range from subtle performance degradation to complete device failure. Precision integrated circuits may be more susceptible to damage because very small parametric changes could cause the device not to meet its published specifications.

10.6 Glossary

[TI Glossary](#) This glossary lists and explains terms, acronyms, and definitions.

11 Mechanical, Packaging, and Orderable Information

The following pages include mechanical, packaging, and orderable information. This information is the most current data available for the designated devices. This data is subject to change without notice and revision of this document. For browser-based versions of this data sheet, refer to the left-hand navigation.

PACKAGING INFORMATION

Orderable part number	Status (1)	Material type (2)	Package Pins	Package qty Carrier	RoHS (3)	Lead finish/ Ball material (4)	MSL rating/ Peak reflow (5)	Op temp (°C)	Part marking (6)
SN65MLVD203BRUMR	Active	Production	WQFN (RUM) 16	3000 LARGE T&R	Yes	SN	Level-1-260C-UNLIM	-40 to 125	MLVD 203B
SN65MLVD203BRUMR.B	Active	Production	WQFN (RUM) 16	3000 LARGE T&R	Yes	SN	Level-1-260C-UNLIM	-40 to 125	MLVD 203B
SN65MLVD203BRUMRG4	Active	Production	WQFN (RUM) 16	3000 LARGE T&R	Yes	NIPDAU	Level-1-260C-UNLIM	-40 to 125	MLVD 203B
SN65MLVD203BRUMRG4.B	Active	Production	WQFN (RUM) 16	3000 LARGE T&R	Yes	NIPDAU	Level-1-260C-UNLIM	-40 to 125	MLVD 203B
SN65MLVD203BRUMT	Active	Production	WQFN (RUM) 16	250 SMALL T&R	Yes	SN	Level-1-260C-UNLIM	-40 to 125	MLVD 203B
SN65MLVD203BRUMT.B	Active	Production	WQFN (RUM) 16	250 SMALL T&R	Yes	SN	Level-1-260C-UNLIM	-40 to 125	MLVD 203B

(1) **Status:** For more details on status, see our [product life cycle](#).

(2) **Material type:** When designated, preproduction parts are prototypes/experimental devices, and are not yet approved or released for full production. Testing and final process, including without limitation quality assurance, reliability performance testing, and/or process qualification, may not yet be complete, and this item is subject to further changes or possible discontinuation. If available for ordering, purchases will be subject to an additional waiver at checkout, and are intended for early internal evaluation purposes only. These items are sold without warranties of any kind.

(3) **RoHS values:** Yes, No, RoHS Exempt. See the [TI RoHS Statement](#) for additional information and value definition.

(4) **Lead finish/Ball material:** Parts may have multiple material finish options. Finish options are separated by a vertical ruled line. Lead finish/Ball material values may wrap to two lines if the finish value exceeds the maximum column width.

(5) **MSL rating/Peak reflow:** The moisture sensitivity level ratings and peak solder (reflow) temperatures. In the event that a part has multiple moisture sensitivity ratings, only the lowest level per JEDEC standards is shown. Refer to the shipping label for the actual reflow temperature that will be used to mount the part to the printed circuit board.

(6) **Part marking:** There may be an additional marking, which relates to the logo, the lot trace code information, or the environmental category of the part.

Multiple part markings will be inside parentheses. Only one part marking contained in parentheses and separated by a "~" will appear on a part. If a line is indented then it is a continuation of the previous line and the two combined represent the entire part marking for that device.

Important Information and Disclaimer: The information provided on this page represents TI's knowledge and belief as of the date that it is provided. TI bases its knowledge and belief on information provided by third parties, and makes no representation or warranty as to the accuracy of such information. Efforts are underway to better integrate information from third parties. TI has taken and continues to take reasonable steps to provide representative and accurate information but may not have conducted destructive testing or chemical analysis on incoming materials and chemicals. TI and TI suppliers consider certain information to be proprietary, and thus CAS numbers and other limited information may not be available for release.

In no event shall TI's liability arising out of such information exceed the total purchase price of the TI part(s) at issue in this document sold by TI to Customer on an annual basis.

TAPE AND REEL INFORMATION

QUADRANT ASSIGNMENTS FOR PIN 1 ORIENTATION IN TAPE

*All dimensions are nominal

Device	Package Type	Package Drawing	Pins	SPQ	Reel Diameter (mm)	Reel Width W1 (mm)	A0 (mm)	B0 (mm)	K0 (mm)	P1 (mm)	W (mm)	Pin1 Quadrant
SN65MLVD203BRUMR	WQFN	RUM	16	3000	330.0	12.4	4.25	4.25	1.15	8.0	12.0	Q2
SN65MLVD203BRUMRG4	WQFN	RUM	16	3000	330.0	12.4	4.25	4.25	1.15	8.0	12.0	Q2
SN65MLVD203BRUMT	WQFN	RUM	16	250	180.0	12.4	4.25	4.25	1.15	8.0	12.0	Q2

TAPE AND REEL BOX DIMENSIONS



*All dimensions are nominal

Device	Package Type	Package Drawing	Pins	SPQ	Length (mm)	Width (mm)	Height (mm)
SN65MLVD203BRUMR	WQFN	RUM	16	3000	367.0	367.0	35.0
SN65MLVD203BRUMRG4	WQFN	RUM	16	3000	367.0	367.0	35.0
SN65MLVD203BRUMT	WQFN	RUM	16	250	210.0	185.0	35.0

GENERIC PACKAGE VIEW

RUM 16

WQFN - 0.8 mm max height

4 x 4, 0.65 mm pitch

PLASTIC QUAD FLATPACK - NO LEAD

This image is a representation of the package family, actual package may vary.
Refer to the product data sheet for package details.

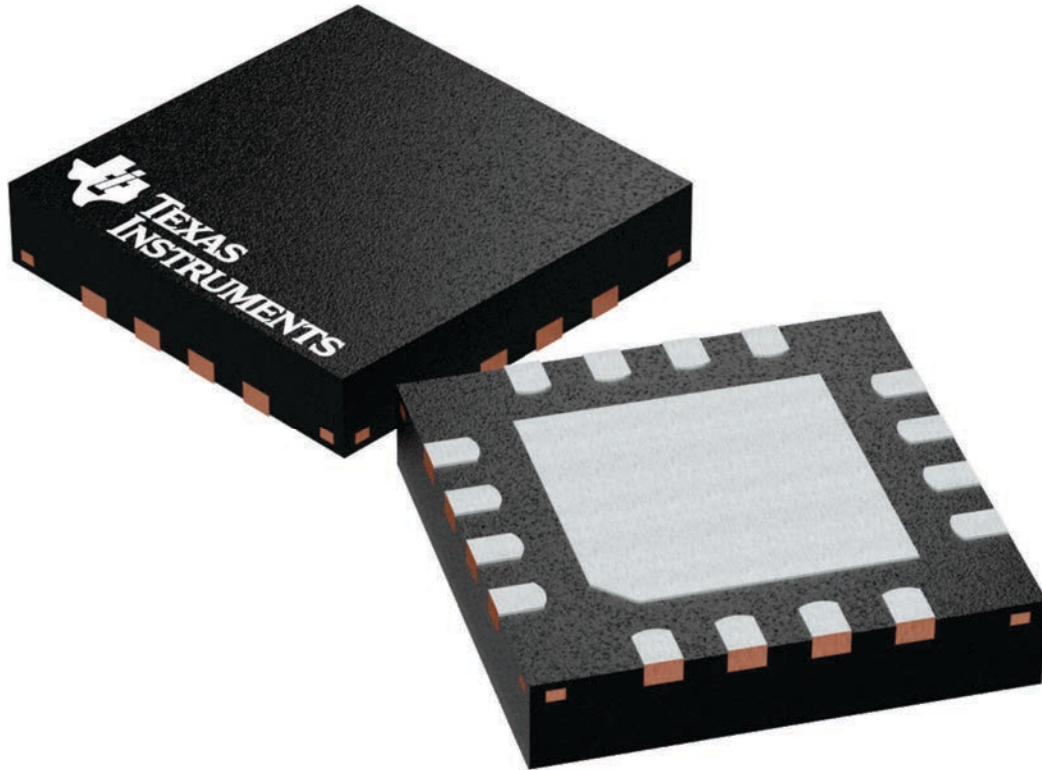

4224843/A

RUM (S-PQFP-N16)

PLASTIC QUAD FLATPACK

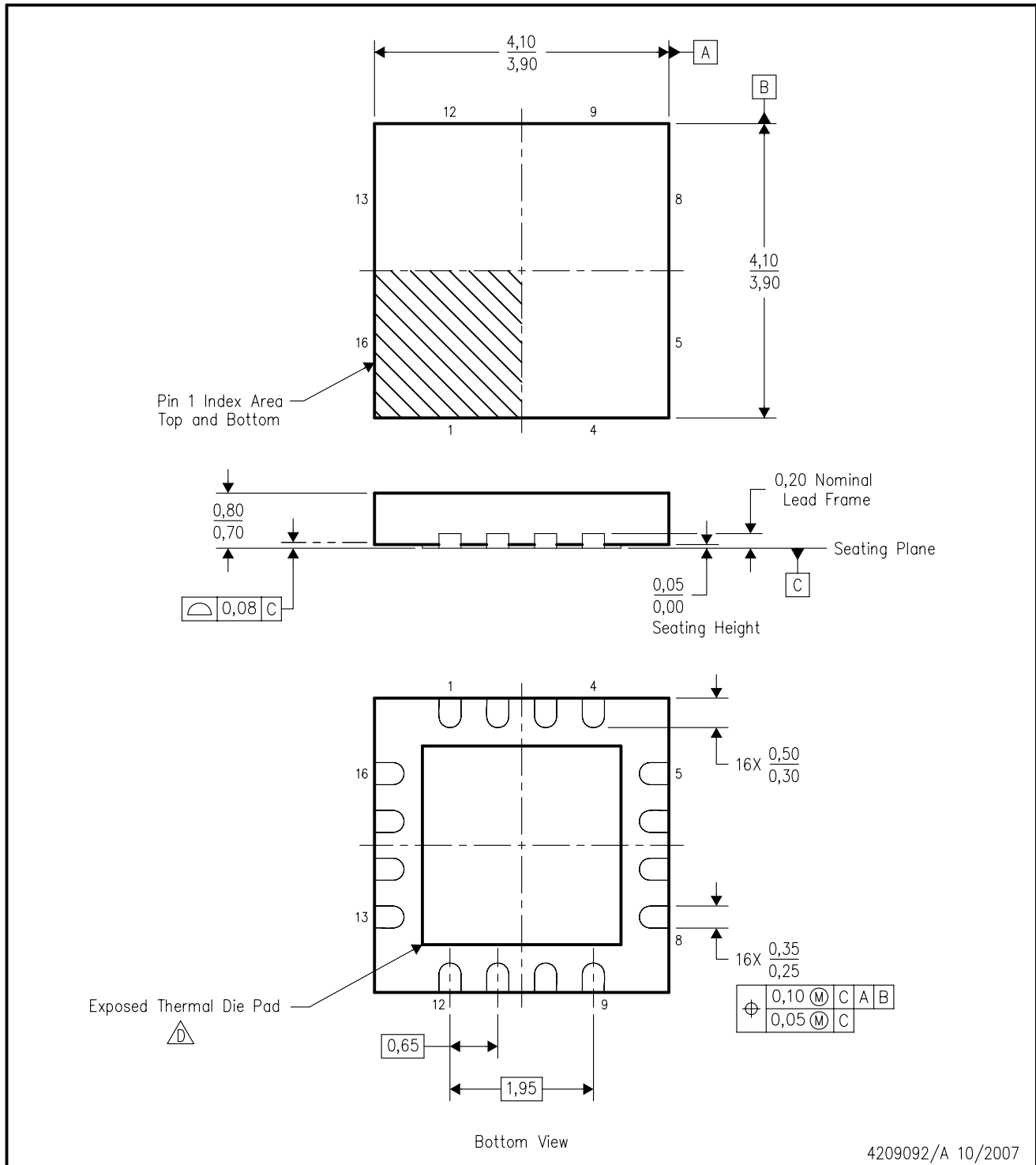

4209092/A 10/2007

- NOTES:
- A. All linear dimensions are in millimeters. Dimensioning and tolerancing per ASME Y14.5M-1994.
 - B. This drawing is subject to change without notice.
 - C. QFN (Quad Flatpack No-Lead) package configuration.
 -  The package thermal pad must be soldered to the board for thermal and mechanical performance. See the Product Data Sheet for details regarding the exposed thermal pad dimensions.
 - E. Package complies to JEDEC MO-220 variation WGGC-3.

THERMAL INFORMATION

This package incorporates an exposed thermal pad that is designed to be attached directly to an external heatsink. The thermal pad must be soldered directly to the printed circuit board (PCB). After soldering, the PCB can be used as a heatsink. In addition, through the use of thermal vias, the thermal pad can be attached directly to the appropriate copper plane shown in the electrical schematic for the device, or alternatively, can be attached to a special heatsink structure designed into the PCB. This design optimizes the heat transfer from the integrated circuit (IC).

For information on the Quad Flatpack No-Lead (QFN) package and its advantages, refer to Application Report, QFN/SON PCB Attachment, Texas Instruments Literature No. SLUA271. This document is available at www.ti.com.

The exposed thermal pad dimensions for this package are shown in the following illustration.

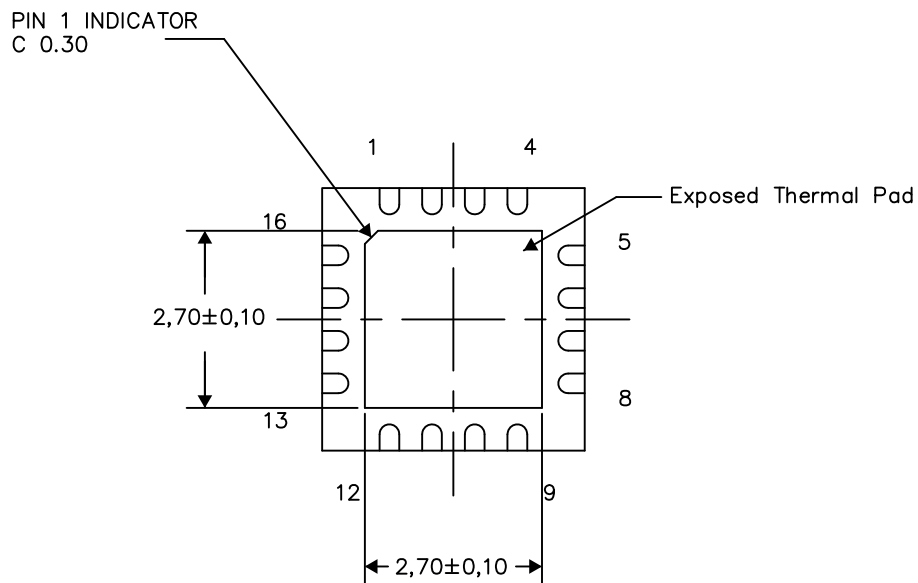

Bottom View

Exposed Thermal Pad Dimensions

4209093-2/F 09/15

NOTES: All linear dimensions are in millimeters

IMPORTANT NOTICE AND DISCLAIMER

TI PROVIDES TECHNICAL AND RELIABILITY DATA (INCLUDING DATASHEETS), DESIGN RESOURCES (INCLUDING REFERENCE DESIGNS), APPLICATION OR OTHER DESIGN ADVICE, WEB TOOLS, SAFETY INFORMATION, AND OTHER RESOURCES "AS IS" AND WITH ALL FAULTS, AND DISCLAIMS ALL WARRANTIES, EXPRESS AND IMPLIED, INCLUDING WITHOUT LIMITATION ANY IMPLIED WARRANTIES OF MERCHANTABILITY, FITNESS FOR A PARTICULAR PURPOSE OR NON-INFRINGEMENT OF THIRD PARTY INTELLECTUAL PROPERTY RIGHTS.

These resources are intended for skilled developers designing with TI products. You are solely responsible for (1) selecting the appropriate TI products for your application, (2) designing, validating and testing your application, and (3) ensuring your application meets applicable standards, and any other safety, security, regulatory or other requirements.

These resources are subject to change without notice. TI grants you permission to use these resources only for development of an application that uses the TI products described in the resource. Other reproduction and display of these resources is prohibited. No license is granted to any other TI intellectual property right or to any third party intellectual property right. TI disclaims responsibility for, and you fully indemnify TI and its representatives against any claims, damages, costs, losses, and liabilities arising out of your use of these resources.

TI's products are provided subject to [TI's Terms of Sale](#), [TI's General Quality Guidelines](#), or other applicable terms available either on [ti.com](#) or provided in conjunction with such TI products. TI's provision of these resources does not expand or otherwise alter TI's applicable warranties or warranty disclaimers for TI products. Unless TI explicitly designates a product as custom or customer-specified, TI products are standard, catalog, general purpose devices.

TI objects to and rejects any additional or different terms you may propose.

Copyright © 2026, Texas Instruments Incorporated

Last updated 10/2025