

TMP118 Ultra-Small (0.336mm²), Ultra-Thin (240µm), Low-Power (65nA, Sleep IQ) ±0.1°C Accurate, I²C Digital Temperature Sensor

1 Features

- **Ultra-small**, ultra-thin PicoStar™ package:
 - Size: 0.55 × 0.61 × 0.24mm
 - Small thermal mass: 0.092mJ/°C
- High-accuracy (V_{DD}= 1.62V to 3.6V):
 - ±0.05°C (typical) from 0°C to 50°C
 - ±0.1°C (maximum) from 20°C to 50°C
 - ±0.15°C (maximum) from 0°C to 50°C
 - ±0.2 °C (maximum) from –20°C to 85°C
 - ±0.4 °C (maximum) from –40°C to 125°C
- Supply range: 1.4V to 5.5V
- 16-bit resolution: 0.0078125°C (LSB)
- Measurement averaging: 0, 4, 8 averages
- Low power consumption:
 - 1.4µA average current, 1Hz conversion cycle
 - 65nA sleep current
- Flexible digital interface:
 - 1.2V compatible logic (independent of V_{DD})
 - I²C and SMBus™ compatible
 - I3C Mixed Bus co-existence capable
- **NIST traceable**: 48-bit unique ID
- Medical grade:
 - Helps meet ASTM E1112 and ISO 80601-2-56
- **GUI-Based C-Code Generator**

2 Applications

- [Mobile Phones](#)
- [Smartwatch](#)
- [Smart Trackers](#)
- [Tablets](#)
- [Medical Sensor Patches](#)

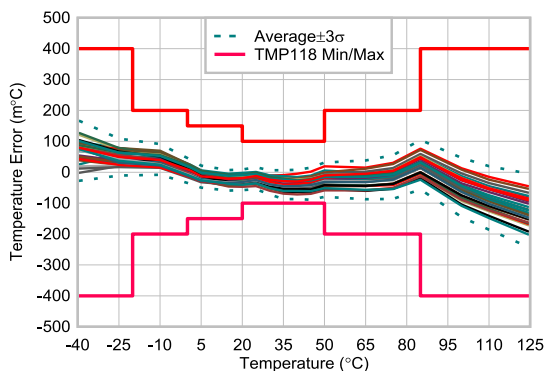

TMP118 Temperature Accuracy (1.8V supply)

3 Description

The TMP118 is an ultra-small, ultra-thin digital temperature sensor in a PicoStar™ package, with an area of 0.336mm², and a maximum height of 240µm. The TMP118 has 16-bit resolution with an LSB of 7.8125m°C, achieving ±0.1°C (max accuracy) from 20°C to 50°C with no additional calibration, which helps meet the system level ASTM E1112 and ISO 80601 accuracy standard for medical-grade electronic thermometers.

Designed for low-power operation, the TMP118 operates from supply voltages as low as 1.4V (up to 5.5V) and draws 55µA when actively converting (approximately 1.4µA at a 1Hz sample rate) and 65nA in shutdown mode, enabling on-demand measurements while maximizing battery life in portable or wearable devices. The TMP118 has an interface that is I²C- and SMBus-compatible and has programmable alert flag functionality. The sensor also supports logic levels down to 1.2V without requiring a level shifter, allowing direct interfacing with low-voltage MCUs.

Additionally, each TMP118 includes a unique device ID for NIST traceability. All units are factory-tested with NIST-traceable equipment calibrated to ISO/IEC 17025 accredited standards.

Package Information

PART NUMBER ⁽¹⁾	PACKAGE	PACKAGE SIZE ⁽²⁾
TMP118	PICOSTAR (4)	0.61mm × 0.55mm

(1) For more information, see [Section 12](#).

(2) The package size (length × width) is a nominal value and includes pins, where applicable.

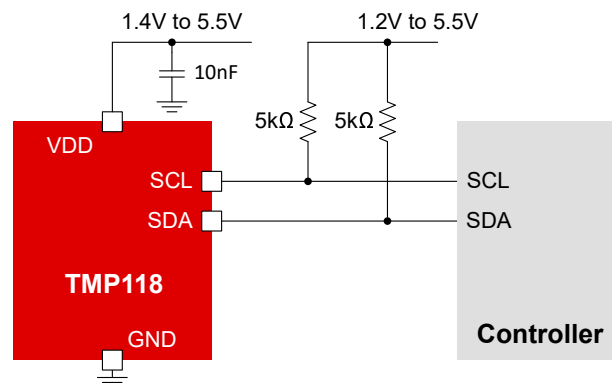

Simplified Schematic



Table of Contents

1 Features	1	7.5 Programming.....	21
2 Applications	1	8 Device Registers	26
3 Description	1	8.1 Register Map.....	26
4 Device Comparison	3	9 Application and Implementation	31
5 Pin Configuration and Functions	5	9.1 Application Information.....	31
6 Specifications	6	9.2 Typical Application.....	31
6.1 Absolute Maximum Ratings.....	6	9.3 Power Supply Recommendations.....	32
6.2 ESD Ratings.....	6	9.4 Layout.....	32
6.3 Recommended Operating Conditions.....	6	10 Device and Documentation Support	34
6.4 Thermal Information.....	6	10.1 Documentation Support.....	34
6.5 Electrical Characteristics.....	7	10.2 Receiving Notification of Documentation Updates..	34
6.6 Two-Wire Interface Timing.....	9	10.3 Support Resources.....	34
6.7 Timing Diagram.....	9	10.4 Trademarks.....	34
6.8 Typical Characteristics.....	10	10.5 Electrostatic Discharge Caution.....	34
7 Detailed Description	14	10.6 Glossary.....	34
7.1 Overview.....	14	11 Revision History	34
7.2 Functional Block Diagrams.....	14	12 Mechanical, Packaging, and Orderable	
7.3 Feature Description.....	14	Information	35
7.4 Device Functional Modes.....	19		

4 Device Comparison

Table 4-1. Device Address Options

DEVICE	7-BIT I ² C TARGET ADDRESS	
	HEX	BINARY
TMP118A/ TMP118MA	0x48	1001000'b
TMP118B/ TMP118MB	0x49	1001001'b
TMP118C/ TMP118MC	0x4A	1001010'b
TMP118D/ TMP118MD	0x4B	1001011'b

Table 4-2. Device Options

Feature	TMP113	TMP114	TMP117	TMP117M	TMP117N	TMP118	TMP118M	TMP119	
V _{DD} (V)	1.4 - 5.5	1.08 - 1.98	1.7 - 5.5	1.7 - 5.5	1.7 - 5.5	1.4 - 5.5	1.4 - 5.5	1.7 - 5.5	
Current Consumption (25°C)									
I _{AVG} at 1Hz (µA)	1.4	0.63	3.5	3.5	3.5	1.4	1.4	3.5	
I _{Q_ACTIVE} (µA)	55	68	135	135	135	55	55	135	
I _{SB} (µA)	0.85	0.26	1.25	1.25	1.25	0.75	0.75	1.25	
I _{SD} (µA)	0.07	0.16	0.25	0.25	0.25	0.065	0.065	0.25	
Accuracy									
0°C to 45°C	(typ)	0.1	0.1	0.05	0.05	0.1	0.05 ⁽¹⁾	0.05 ⁽¹⁾	0.03
	(max)	0.3	0.2	0.1	0.1	0.2	0.15 ⁽¹⁾	0.2 ⁽¹⁾	0.08
-55°C (max)	-	-	0.25	-	0.3	-	-	0.15	
-40°C (max)	0.75	0.5	0.15	-	0.2	0.4	-	0.11	
-20°C (max)	0.5	0.5	0.1	-	0.2	0.2 ⁽¹⁾	0.2 ⁽¹⁾	0.09	
-10°C (max)	0.5	0.3	0.1	-	0.2	0.2 ⁽¹⁾	0.2 ⁽¹⁾	0.09	
0°C (max)	0.3	0.3	0.1	0.15	0.2	0.15 ⁽¹⁾	0.15 ⁽¹⁾	0.08	
20°C (max)	0.3	0.2	0.1	0.1	0.2	0.1 ⁽¹⁾	0.1 ⁽¹⁾	0.08	
45°C (max)	0.3	0.2	0.1	0.1	0.2	0.1 ⁽¹⁾	0.1 ⁽¹⁾	0.08	
60°C (max)	0.3	0.3	0.15	0.15	0.2	0.2 ⁽¹⁾	0.2 ⁽¹⁾	0.09	
85°C (max)	0.5	0.5	0.2	0.2	0.2	0.2 ⁽¹⁾	0.2 ⁽¹⁾	0.15	
100°C (max)	0.75	0.5	0.2	-	0.2	0.4	-	0.15	
125°C (max)	0.75	0.5	0.25	-	0.25	0.4	-	0.2	
150°C (max)	-	-	0.3	-	0.3	-	-	0.2	
Packaging Dimension									
Dimensions [mm × mm × mm]	BGA: 1.49 × 0.95 × 0.531	PicoStar™: 0.76 × 0.76 × 0.15	BGA: 1.49 × 0.95 × 0.531 WSON: 2.0 × 2.0 × 0.8			PicoStar™: 0.61 × 0.55 × 0.24		BGA: 1.49 × 0.95 × 0.525	
Features									
I ² C Addresses	ADD0 Pin (4)	Factory Set (4)	ADD0 Pin (4)			Factory Set (4)		ADD0 Pin (4)	
NIST Traceable	Yes	No	Yes	Yes	Yes	Yes	Yes	Yes	

(1) Accuracy specified over V_{DD} = 1.62 - 3.6V. The max accuracy is ±0.4°C for the full V_{DD} range (1.4V to 5.5V)

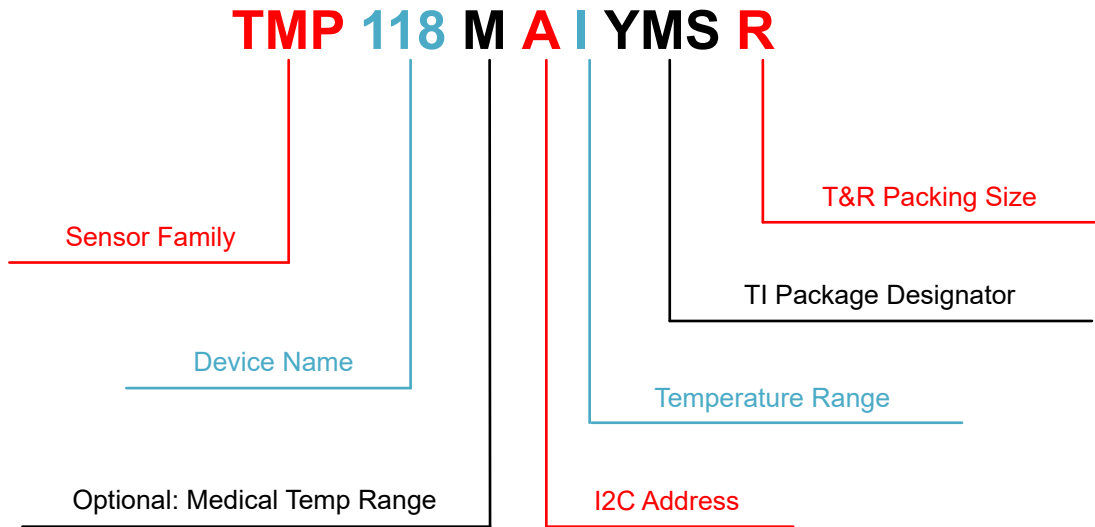

Figure 4-1. TMP118 Device Nomenclature

Table 4-3. TMP118 Device Nomenclature Detail

Field Description	Field Detail
Sensor Family	TMP: Temperature Sensors
Device Name	118
Device Type (Optional)	<ul style="list-style-type: none"> TMP118 TMP118M for Medical Temperature Range
I2C Address	<ul style="list-style-type: none"> TMP118A/ TMP118MA - 0x48/ 1001000'b TMP118B/ TMP118MB - 0x49/ 1001001'b TMP118C/ TMP118MC - 0x4A/ 1001010'b TMP118D/ TMP118MD - 0x4B/ 1001011'b
Temperature Range	<ul style="list-style-type: none"> Standard Temp Range (TMP118xl): -40°C to 125°C Medical Temp Range (TMP118Mxl): -20°C to 85°C
TI Package Designator	YMS, PicoStar™ package, 0.3mm pitch
T&R Packing Size	Large T&R, SPQ = 12,000 units

5 Pin Configuration and Functions

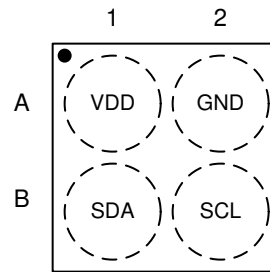

Figure 5-1. YMS Package, 4-Pin PICOSTAR (Top View)

Table 5-1. Pin Functions

PIN		TYPE ⁽¹⁾	DESCRIPTION
NAME	PICOSTAR-4		
VDD	A1	I	Supply voltage
SDA	B1	I/O	Serial data input and open-drain output. Requires a pullup resistor.
GND	A2	-	Ground
SCL	B2	I	Serial Clock

(1) I = Input; O = Output, I/O = Input or Output

6 Specifications

6.1 Absolute Maximum Ratings

Over free-air temperature range unless otherwise noted⁽¹⁾

		MIN	MAX	UNIT
Supply voltage	V_{DD}	-0.3	6	V
Input/Output Voltage	SCL, SDA	-0.3	6	V
Operating temperature, T_A		-40	125	°C
Storage temperature, T_{stg}		-65	150	°C

- (1) Operation outside the *Absolute Maximum Ratings* may cause permanent device damage. *Absolute Maximum Ratings* do not imply functional operation of the device at these or any other conditions beyond those listed under *Recommended Operating Conditions*. If used outside the *Recommended Operating Conditions* but within the *Absolute Maximum Ratings*, the device may not be fully functional, and this may affect device reliability, functionality, performance, and shorten the device lifetime.

6.2 ESD Ratings

			VALUE	UNIT
$V_{(ESD)}$	Electrostatic discharge	Human-body model (HBM), per ANSI/ESDA/JEDEC JS-001 ⁽¹⁾	±2000	V
		Charged-device model (CDM), per JEDEC specification JESD22-C101 ⁽²⁾	±500	

- (1) JEDEC document JEP155 states that 500V HBM allows safe manufacturing with a standard ESD control process.
(2) JEDEC document JEP157 states that 250V CDM allows safe manufacturing with a standard ESD control process.

6.3 Recommended Operating Conditions

		MIN	NOM	MAX	UNIT
V_{DD}	Supply voltage	1.4		5.5	V
V_{IO}	SCL, SDA	1.08		5.5	V
I_{OL}	Output current	0		2	mA
T_A	Operating free-air temperature	-40		125	°C

6.4 Thermal Information

THERMAL METRIC ⁽¹⁾		TMP118	Unit
		YMS (PICOSTAR-4)	
		4 PINS	
$R_{\theta JA}$	Junction-to-ambient thermal resistance	218.7	°C/W
$R_{\theta JC(top)}$	Junction-to-case (top) thermal resistance	2.7	°C/W
$R_{\theta JB}$	Junction-to-board thermal resistance	68.3	°C/W
Ψ_{JT}	Junction-to-top characterization parameter	1.3	°C/W
Ψ_{JB}	Junction-to-board characterization parameter	68.1	°C/W
M_T	Thermal mass	0.092	mJ/°C

- (1) For more information about traditional and new thermal metrics, see the [Semiconductor and IC Package Thermal Metrics](#) application note.

6.5 Electrical Characteristics

Over free-air temperature range and $V_{DD} = 1.4V$ to $5.5V$ for $T_A = -40^\circ C$ to $125^\circ C$ (unless otherwise noted); Typical specifications are at $T_A = 25^\circ C$ and $V_{DD} = 1.8V$ (unless otherwise noted)

PARAMETER		TEST CONDITIONS		MIN	TYP	MAX	UNIT	
TEMPERATURE TO DIGITAL CONVERTER								
T_{ERR}	Temperature accuracy	TMP118	8x averaging 1-Hz conversion cycle, serial bus idle, $V_{DD} = 1.62V$ to $3.6V^{(1)}$	20°C to 50°C	-0.1	±0.05	0.1	°C
				0°C to 50°C	-0.15		0.15	
				-20°C to 85°C	-0.2		0.2	
		TMP118M	8x averaging 1-Hz conversion cycle, serial bus idle, $V_{DD} = 1.4V$ to $5.5V$	-40°C to 125°C	-0.4		0.4	
				20°C to 50°C	-0.1		0.1	
					10°C to 50°C	-0.15		
TMP118M	8x averaging 1-Hz conversion cycle, serial bus idle, $V_{DD} = 1.62V$ to $3.6V^{(1)}$	-20°C to 85°C	-0.2		0.2			
		-20°C to 85°C	-0.4		0.4			
PSR_{DC}	DC power supply sensitivity	1.62V to 5.5V			17		m°C/V	
T_{RES}	Temperature resolution (LSB)				7.8125		m°C	
T_{REPEAT}	Repeatability ⁽²⁾	8x averaging			±1		LSB	
		No averaging			±2			
T_{LTD}	Long-term stability and drift	3000 hours at 125°C, $V_{DD} = 5.5V$			0.024		°C	
T_{HYS}	Temperature cycling and hysteresis ⁽³⁾	8 averages			±2		LSB	
t_{LIQUID}	Response time (stirred liquid)	$\tau = 63\%$ for step response from 25 °C to 75 °C	Single layer Flex PCB 0.13mm thickness		0.11		s	
			Single layer FR4 PCB 1.575mm thickness		1.4		s	
t_{CONV}	Conversion time	One-shot mode			11.1		ms	
T_{GAIN}	Gain error	Temp Error Drift over 10 °C to 50 °C; Continuous sweep; Normalized at 35 °C			-0.4		0.4	%
DIGITAL INPUT/OUTPUT								
C_{IN}	Input capacitance	$f = 100kHz$			3		pF	
V_{IH}	Input logic high level				1		V	
V_{IL}	Input logic low level					0.4	V	
I_{IN}	Input leakage current				-0.1		0.1	µA
V_{OL}	SDA output logic low level	$I_{OL} = -2mA$				0.25	V	
POWER SUPPLY								
I_{DD_ACTIVE}	Supply current during active conversion	Active conversion, serial bus idle			55	100	µA	
I_{DD_AVG}	Average current consumption	Continuous conversion mode 1 Hz conversion frequency	Serial bus idle, no averaging		1.4		4	µA
			Serial bus idle, 8x averaging		4.8		12	
			SCL frequency = 400kHz, no averaging ⁽⁵⁾		5.3			
I_{DD_SB}	Standby current ⁽⁴⁾	Continuous conversion mode, serial bus idle			0.75		3	µA

TMP118

SNIS237A – DECEMBER 2024 – REVISED APRIL 2025

Over free-air temperature range and $V_{DD} = 1.4V$ to $5.5V$ for $T_A = -40^{\circ}C$ to $125^{\circ}C$ (unless otherwise noted); Typical specifications are at $T_A = 25^{\circ}C$ and $V_{DD} = 1.8V$ (unless otherwise noted)

PARAMETER		TEST CONDITIONS		MIN	TYP	MAX	UNIT
I_{DD_SD}	Shutdown current	Serial bus idle	25 °C		0.065	0.25	μA
			0 °C to 55 °C		0.11	0.3	
			-40 °C to 125 °C			1.5	
V_{POR}	Power-on reset threshold voltage	Supply voltage rising		1.07			V
V_{BOR}	Brownout detect	Supply voltage falling				0.9	V
t_{INIT}	Initialization time after power-on reset ⁽⁶⁾				1		ms
t_{RESET}	Reset Time ⁽⁷⁾	General Call Reset			0.1		ms

- (1) For V_{DD} above 3.6V, refer to the PSR_{DC} specification to calculate the accuracy shift as a result of the power supply variation
- (2) Repeatability is the ability to reproduce a reading when the measured temperature is applied consecutively, under the same conditions.
- (3) Hysteresis is defined as the ability to reproduce a temperature reading as the temperature varies from room → hot → room → cold → room. The temperatures used for this test are $-40^{\circ}C$, $25^{\circ}C$, and $125^{\circ}C$.
- (4) Quiescent current between conversions
- (5) For best temperature measurement accuracy, avoid any serial bus traffic during active temperature conversion.
- (6) From device power-on reset to start of temperature conversion
- (7) From General Call Reset command received to start of temperature conversion

6.6 Two-Wire Interface Timing

Over free-air temperature range and $V_{DD} = 1.4V$ to $5.5V$ for $T_A = -40\text{ }^\circ\text{C}$ to $125\text{ }^\circ\text{C}$ (unless otherwise noted)

		STANDARD		FAST-MODE		FAST-MODE PLUS		UNIT
		Min	Max	Min	Max	Min	Max	
$f_{(SCL)}$	SCL operating frequency	1	100	100	400	400	1000	kHz
$t_{(BUF)}$	Bus-free time between STOP and START conditions	4.7		1.3		0.5		μs
$t_{(SUSTA)}$	Repeated START condition setup time	4.7		0.6		0.26		μs
$t_{(HDSTA)}$	Hold time after repeated START condition. After this period, the first clock is generated.	4.0		0.6		0.26		μs
$t_{(SUSTO)}$	STOP condition setup time	4.0		0.6		0.26		μs
$t_{(HDDAT)}$	Data hold time ⁽¹⁾	0		0		0		ns
$t_{(SUDAT)}$	Data setup time	250		100		50		ns
$t_{(LOW)}$	SCL clock low period	4.7		1.3		0.5		μs
$t_{(HIGH)}$	SCL clock high period	4.0		0.6		0.26		μs
$t_{(VDAT)}$	Data valid time (data response time) ⁽²⁾		3.45		0.9		0.45	μs
t_R	SDA, SCL rise time		1000	20	300		120	ns
t_F	SDA, SCL fall time		300		300		120	ns
t_{timeout}	Timeout	30		30		30		ms
t_{LPF}	Glitch suppression filter	50		50		50		ns

(1) The maximum $t_{(HDDAT)}$ can be $0.9\mu\text{s}$ for Fast-Mode, and is less than the maximum $t_{(VDAT)}$ by a transition time.

(2) $t_{(VDAT)}$ = time for data signal from SCL "LOW" to SDA output ("HIGH" to "LOW", depending on which is worse).

6.7 Timing Diagram

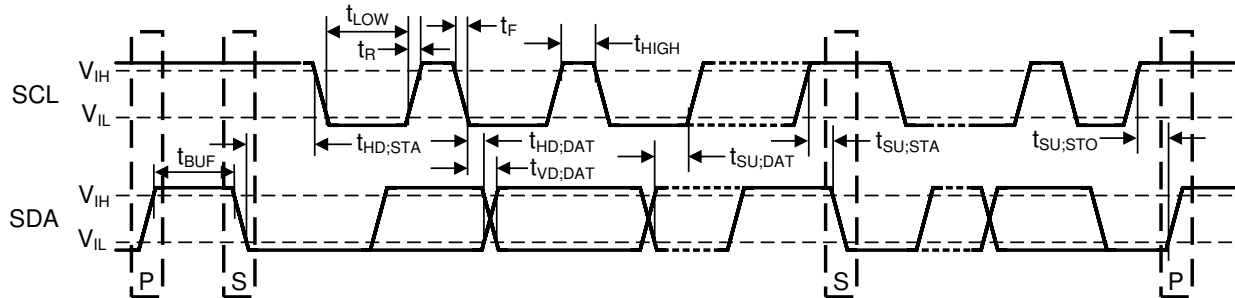

Figure 6-1. Two-Wire Interface Timing Diagram

6.8 Typical Characteristics

at $T_A = 25^\circ\text{C}$, $V_+ = 1.8\text{V}$ (unless otherwise noted)

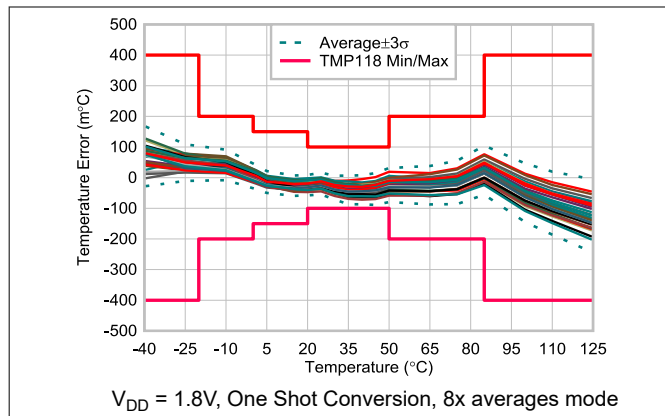

Figure 6-2. TMP118 Temperature Error vs Temperature

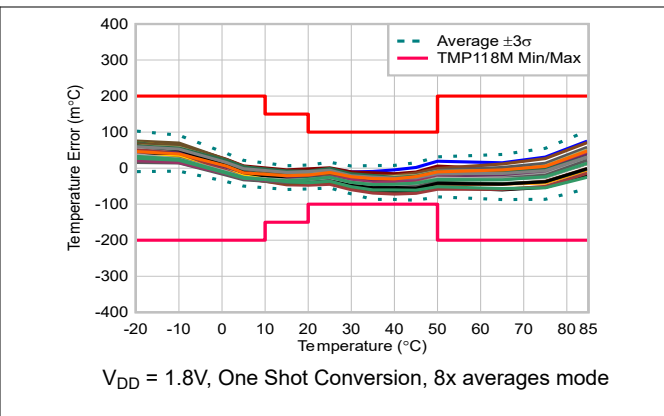

Figure 6-3. TMP118M Temperature Error vs Temperature

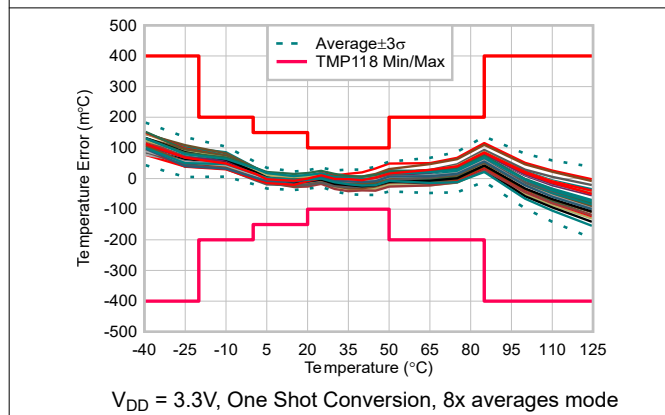

Figure 6-4. TMP118 Temperature Error vs Temperature

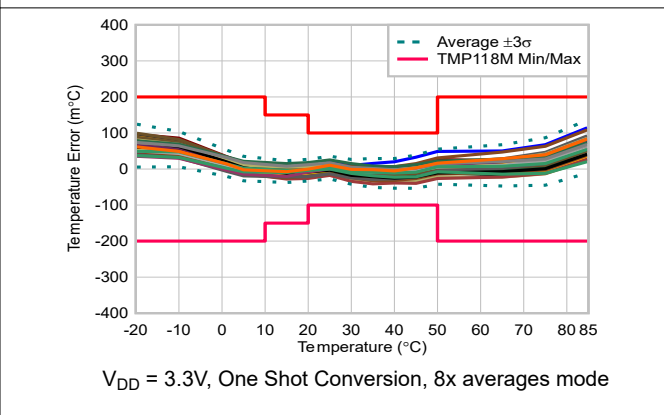

Figure 6-5. TMP118M Temperature Error vs Temperature

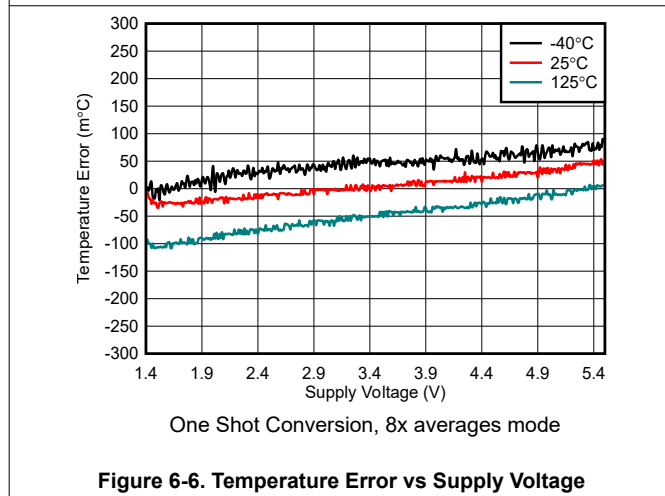

Figure 6-6. Temperature Error vs Supply Voltage

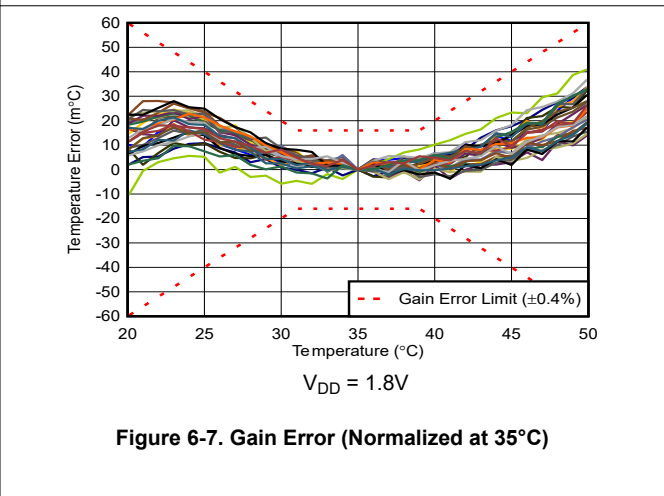
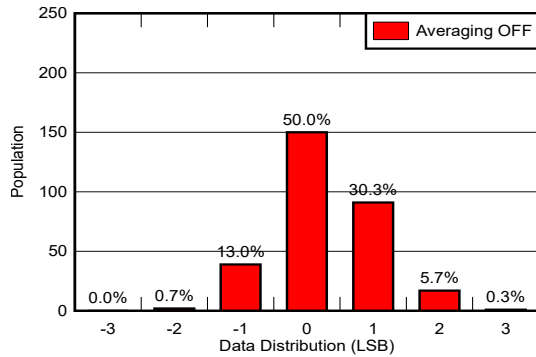

Figure 6-7. Gain Error (Normalized at 35°C)

6.8 Typical Characteristics (continued)

at $T_A = 25^\circ\text{C}$, $V_+ = 1.8\text{V}$ (unless otherwise noted)



One Shot Conversion, No Averaging, $T_A = -40^\circ\text{C}$ to 125°C

Figure 6-8. Temperature Data Noise Distribution

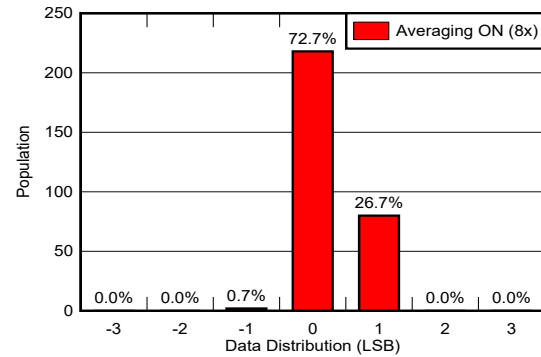

One Shot Conversion, 8x Back-to-back Averaging, $T_A = -40^\circ\text{C}$ to 125°C

Figure 6-9. Temperature Data Noise Distribution

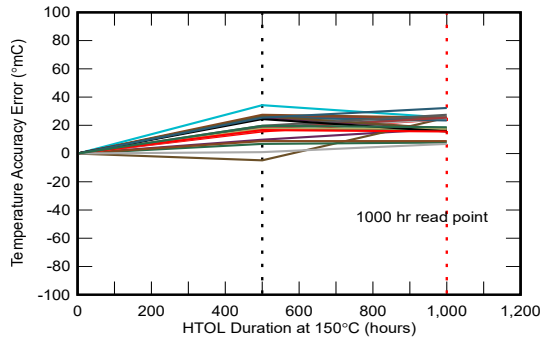

High temperature (150°C) stress testing with temperature error data measurement at 500hr and 1000hr stress duration

Figure 6-10. Long-term Temperature Stability

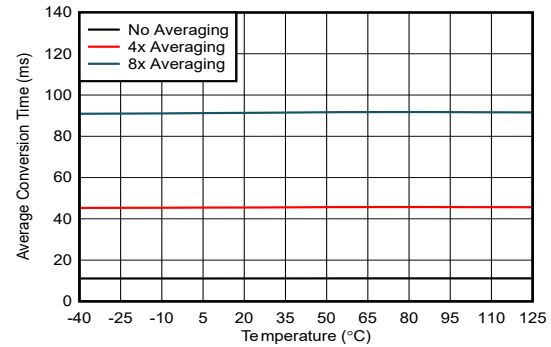

$V_{DD} = 1.4\text{V}$ to 5.5V

Figure 6-11. Average Conversion Time vs Temperature

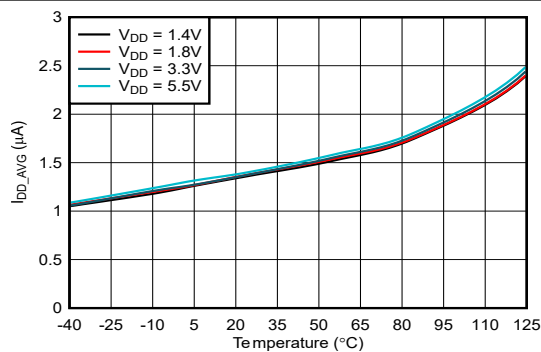

1Hz Conversion Rate, No Averaging

Figure 6-12. Average Quiescent Current vs Temperature

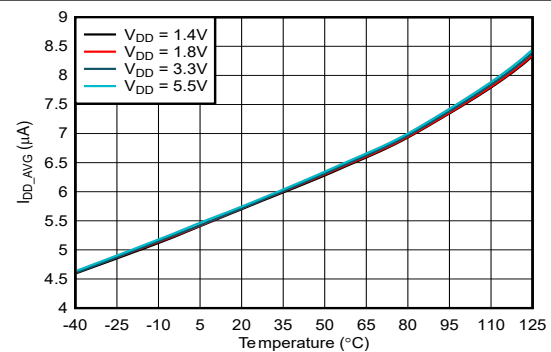

1Hz Conversion Rate, 8x Back-to-back Averaging

Figure 6-13. Average Quiescent Current vs Temperature

6.8 Typical Characteristics (continued)

at $T_A = 25^\circ\text{C}$, $V_+ = 1.8\text{V}$ (unless otherwise noted)

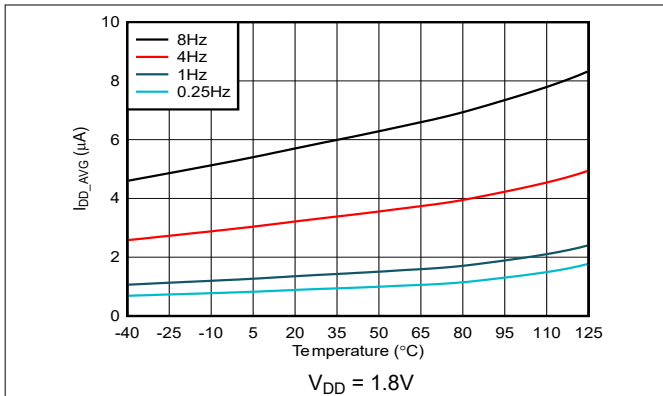

Figure 6-14. Average Quiescent Current vs Temperature

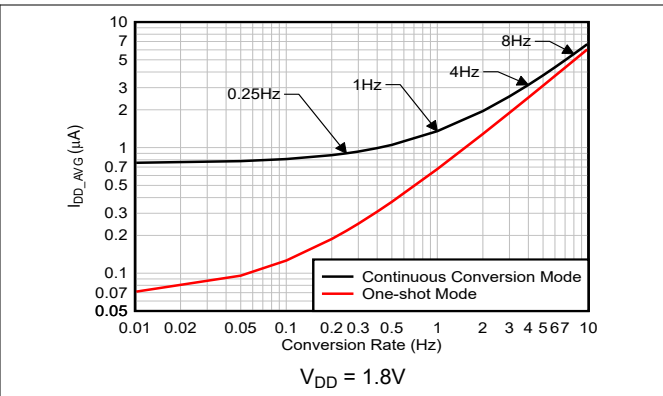

Figure 6-15. Average Quiescent Current vs Conversion Rate

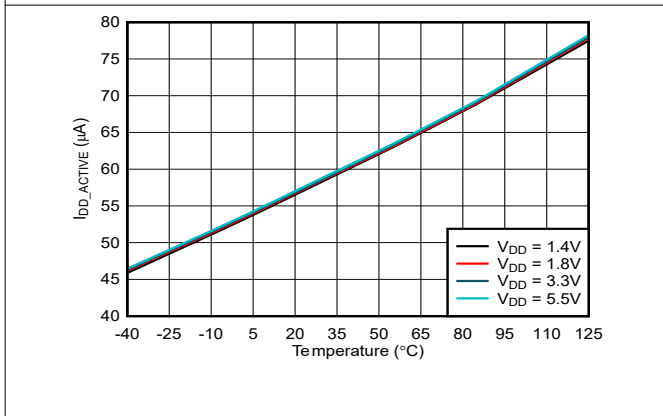

Figure 6-16. Active Conversion Current vs Temperature

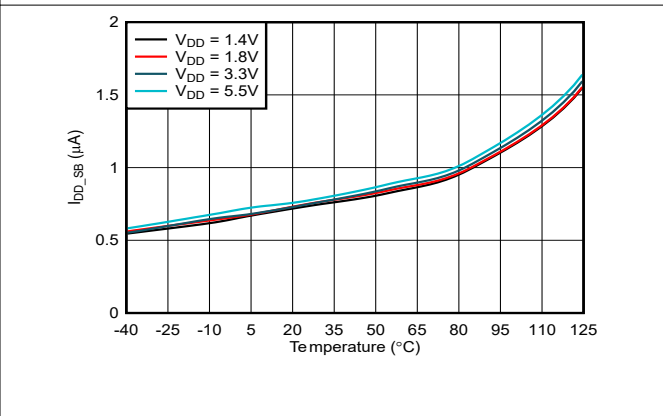

Figure 6-17. Standby Current vs Temperature

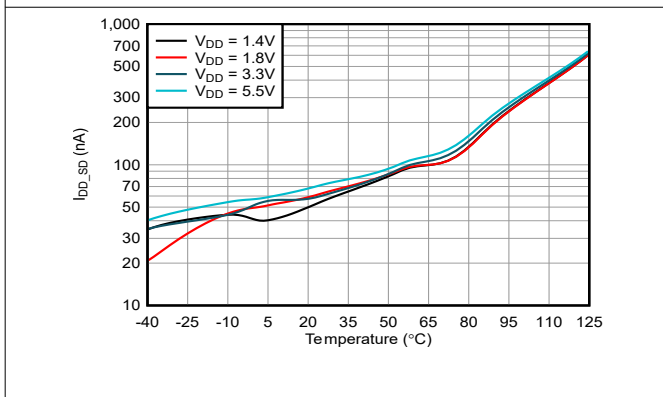

Figure 6-18. Shutdown Current vs Temperature

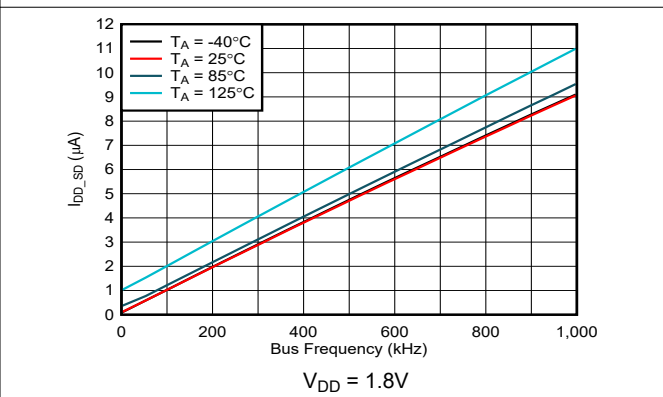

Figure 6-19. Shutdown Current vs Bus Frequency

6.8 Typical Characteristics (continued)

at $T_A = 25^\circ\text{C}$, $V_+ = 1.8\text{V}$ (unless otherwise noted)

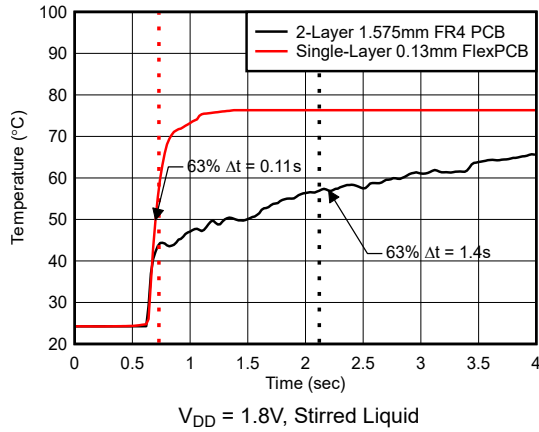

Figure 6-20. Temperature Measurement Response Time

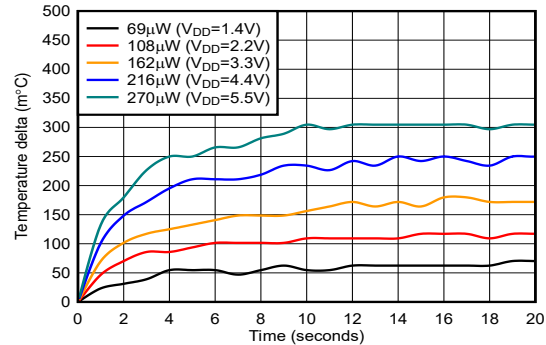

Figure 6-21. Worst Case Temperature Error From Self-heating (8x Back-to-back Averaging)

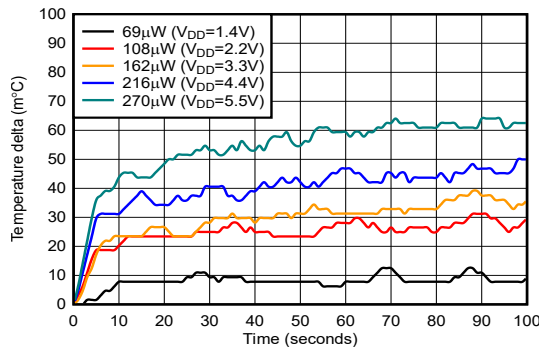

Figure 6-22. Worst Case Temperature Error From Self-heating (8x Back-to-back Averaging)

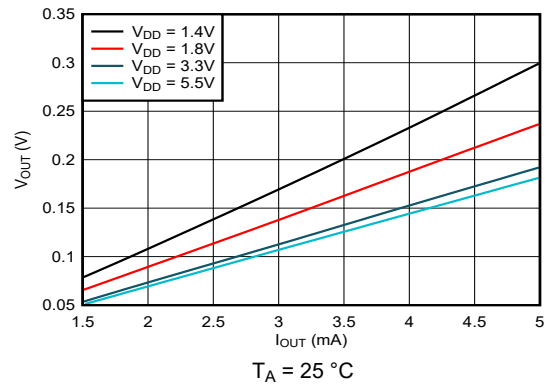

Figure 6-23. SDA Output Voltage vs Load Current

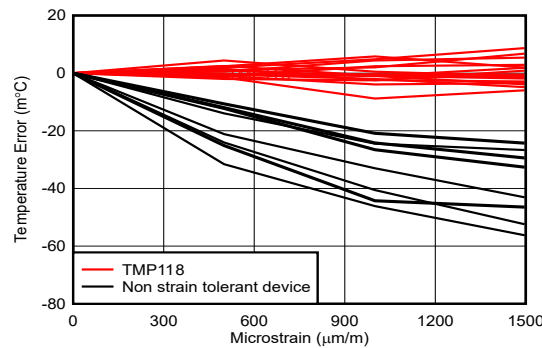

Figure 6-24. Normalized Temperature Error vs Strain

7 Detailed Description

7.1 Overview

The TMP118 is a digital output temperature sensor designed for high-accuracy, space constrained applications that comes factory calibrated for accuracy. The device features a two-wire, SMBus and I²C compatible interface with two modes of operation: continuous conversion mode and one-shot conversion mode. The TMP118 also includes an alert status flag with individual high and low thresholds registers. The device is specified over an ambient air operating temperature range of -40 °C to 125 °C. [Figure 7-1](#) shows a block diagram of the device.

7.2 Functional Block Diagrams

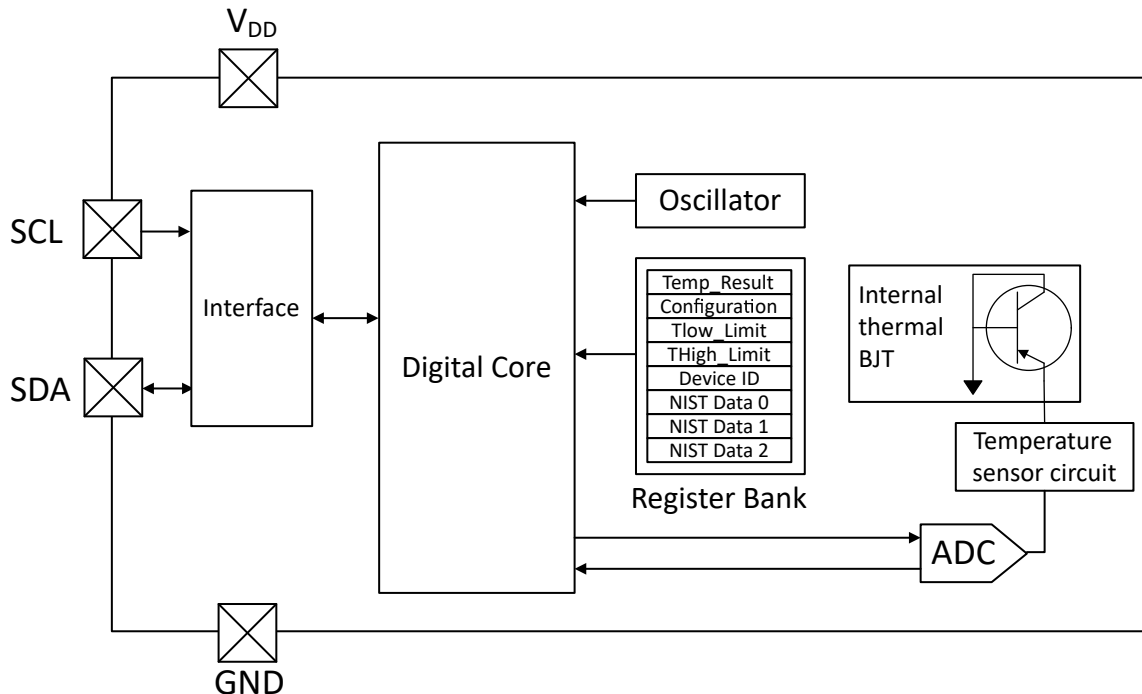

Figure 7-1. Internal Block Diagram

7.3 Feature Description

7.3.1 Digital Temperature Output

The Temp_Result registers use a 16-bit format. Temperature data is represented by a 16-bit 2's complement word with a Least Significant Bit (LSB) equal to 0.0078125°C. The fractional values are included in the temperature readings, which can be denoted using Q notation, a simple way to represent the length of the fractional portion of the value. 2's Compliment is employed to describe negative temperatures. C code can easily convert the 2's Compliment data when the data is typecast into the correct signed data type. For more details on using Q notation to decode digital temperature data, refer to [How to Read and Interpret Digital Temperature Sensor Output Data](#).

Note following power-up or reset, the temperature register reads 0°C until the first conversion is complete. Also note the decoding scheme allows temperature measurement beyond the recommended operating temperature range of -40°C to 125°C, but the device performance is not guaranteed beyond this range.

Table 7-1. Encoding Parameters

Parameter	Value
Bits	16
Q	7
Resolution	0.0078125
Range (+)	255.9921875

Table 7-1. Encoding Parameters (continued)

Parameter	Value
Range (-)	-256
25°C	0xC80

Table 7-2. 16-Bit Q Notation Bit Weights

	15	14	13	12	11	10	9	8	7	6	5	4	3	2	1	0
Sign	128	64	32	16	8	4	2	1	0.5	0.25	0.125	0.0625	0.03125	0.015625	0.0078125	0.00390625
-256	128	64	32	16	8	4	2	1	1/2	1/4	1/8	1/16	1/32	1/64	1/128	1/256
-2 ⁸	2 ⁷	2 ⁶	2 ⁵	2 ⁴	2 ³	2 ²	2 ¹	2 ⁰	2 ⁻¹	2 ⁻²	2 ⁻³	2 ⁻⁴	2 ⁻⁵	2 ⁻⁶	2 ⁻⁷	2 ⁻⁸

```

C Code Examples:
/* 16-bit format has 0 bits discarded by right shift
q7 is 0.0078125 resolution
the following bytes represent 24.5C */
uint8_t byte1 = 0xC;
uint8_t byte2 = 0x40;
float f = ((int8_t) byte1 << 8 | byte2) * 0.0078125f;
int mC = ((int8_t) byte1 << 8 | byte2) * 1000 >> 7;
int c = ((int8_t) byte1 << 8 | byte2) >> 7;
    
```

Table 7-3 shows some example temperatures and the converted register values in binary and hexadecimal format. Go to the [TMP118 GUI-based code generator](#) to find MCU-agnostic C-code driver.

Table 7-3. 16-Bit Temperature Data Format

TEMPERATURE (°C)	DIGITAL OUTPUT (BINARY)	HEX
125	0011 1110 1000 0000	3E80
100	0011 0010 0000 0000	3200
80	0010 1000 0000 0000	2800
75	0010 0101 1000 0000	2580
50	0001 1001 0000 0000	1900
25	0000 1100 1000 0000	0C80
0.25	0000 0000 0010 0000	0020
0.0625	0000 0000 0000 1000	0008
0.0078125	0000 0000 0000 0001	0001
0	0000 0000 0000 0000	0000
-0.0078125	1111 1111 1111 1111	FFFF
-0.0625	1111 1111 1111 1100	FFF8
-0.25	1111 1111 1110 0000	FFE0
-25	1111 0011 1000 0000	F380
-40	1110 1100 0000 0000	EC00

7.3.2 Averaging

The device supports 4 different averaging modes to help suppress noise as well as reduce the impact from external temperature fluctuations. The AVG [3:2] bits in the [Configuration register](#) can be programmed to control the averaging behavior of the device:

- **No Averaging [00b]:** The device performs 1 single conversion per conversion period, and temperature result is stored immediately into the Temp_Result register at the end of every conversion.

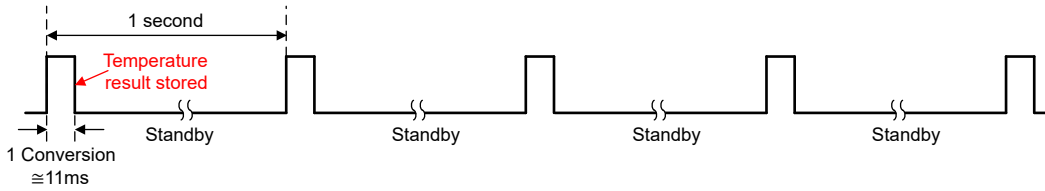

Figure 7-2. Conversion (1Hz Conversion Rate Example) With No Averaging

- Back-to-back Averaging [01b or 10b]: The device accumulates and stores a number of temperature conversion results and reports the average of all the stored results at the end of the process. If AVG [3:2] is set to 01b, 4 conversions are executed back-to-back in every conversion period and the average temperature result is stored into the Temp_Result register after the 4 conversions are completed. If AVG [3:2] is set to 10b, 8 conversions are executed back-to-back in every conversion period and the average temperature result is stored into the Temp_Result register after the 8 conversions are completed.

The Back-to-back Averaging feature is useful to reduce the impact from the internal noise sources of the device, such as the device thermal noise and ADC quantization noise. Figure 6-8 and Figure 6-9 illustrates the improved noise performance of the device as a result of turning on the 8x regular averaging. Note Back-to-back Averaging increases the average current consumption of the device due to increased active conversion time in every conversion period.

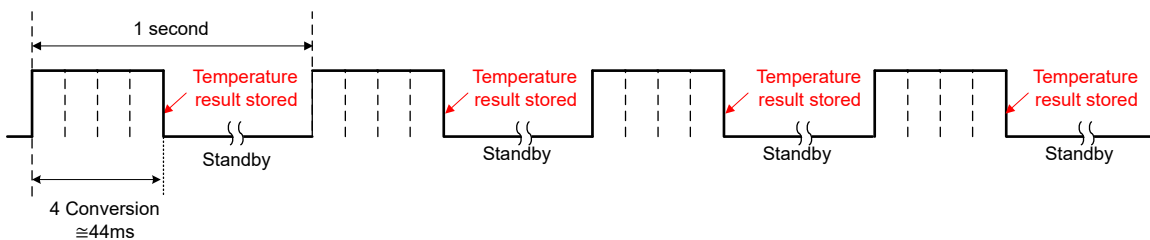

Figure 7-3. Conversion (1Hz Conversion Rate Example) With 4x Back-to-Back Averaging

- Moving 4x Averaging [11b]: If AVG [3:2] is set to 11b, the device performs 1 single conversion per conversion period, and the new temperature result is averaged together with the results from the 3 previous conversion period and stored into the Temp_Result register. The moving averaging feature can be beneficial to filter out fluctuation of external temperature source by taking multiple samples and averaging out the result.

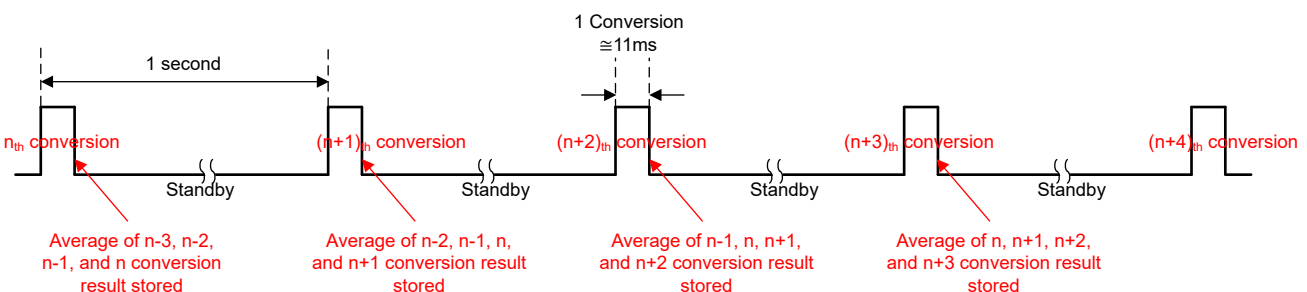

Figure 7-4. Conversion (1Hz Conversion Period) With 4x Running Averaging

Note

Averaging can be used in both the continuous conversion mode and the one-shot mode. Note for the two faster conversion rate settings (Conversion_Rate[1:0]= 10b (15.625ms / 64Hz) or 11b (7.812ms / 128Hz)), 4x Averaging and 8x Averaging cannot be applied due to timing violation. Programming the AVG[1:0] setting to 4x Averaging (01b) or 8x Averaging (10b) causes the device to automatically revert to the 1Hz conversion rate. Using the Moving 4x Averaging (AVG[1:0]= 11b) setting is recommended if averaging feature is desired for the two faster conversion rate settings.

7.3.3 Temperature Comparator and Hysteresis

The TMP118 has a temperature comparator feature that uses the `THigh_Limit` register for high temperature comparator threshold and the `TLow_Limit` register for low temperature comparator threshold. The low temperature comparator threshold is used to program the comparator hysteresis. The comparator thresholds are programmed in the TMP118 in a 16-bit two's complement format and with a resolution of 7.8125m°C. The `Alert_Flag` bit in the `Configuration` register is asserted when the temperature result equals or exceeds the `THigh_Limit` for a consecutive number of conversions as set by the Fault bits in the `Configuration` Register, which can be programmed to 1, 2, 4, or 6 consecutive conversions. The `Alert_Flag` clears when the temperature result drops below the `TLow_Limit` for the same consecutive number of conversions. The difference between the two limits acts as a hysteresis on the comparator output, and the fault counter prevents false alerts as a result of environmental temperature fluctuations. The `Alert_Flag` can be programmed to active low or active high by configuring the Polarity bit in the `Configuration` Register.

As shown in [Figure 7-5](#), the alert status becomes active when the temperature equals or exceeds the value in `THigh_Limit` for Fault number of consecutive conversions. The alert status remains active until the temperature falls below the `TLow_Limit` for the same number of consecutive conversions. The `Alert_Flag` can also be cleared by issuing the General Call Reset command.

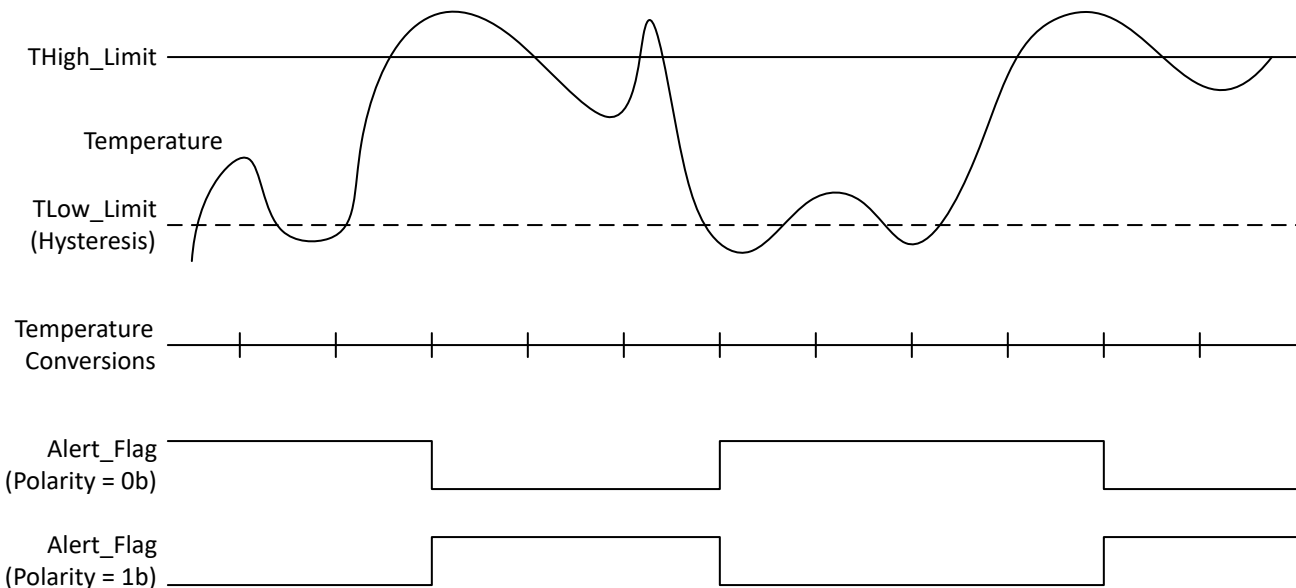

Figure 7-5. Alert_Flag Behavior

7.3.4 Strain Tolerance

The TMP118 features internal strain tolerance that helps mitigate error resulting from strain developed in the PicoStar package from various common manufacturing areas, including but not limited to device solder, molding, under-fill, and board flex.

To demonstrate this capability, multiple TMP118 devices are soldered onto a rigid 62mil thick PCB, and tested under multiple compression and tensile flexing orientations, with pin 1 located both orthogonal and parallel to the applied microstrain examined during the test, measured through a strain gauge. The test is performed under room temperature condition (30°C) V_{DD} of 1.8V, and continuous conversion mode (1Hz conversion interval) with 8x averaging turned on. The resultant temp error under this strain is measured against a known reference, and are recorded at increasing flex levels of the PCB. [Figure 7-6](#) demonstrates device distribution under these microstrain conditions. Several non-strain tolerant devices is also subjected to the same test to demonstrate the difference.

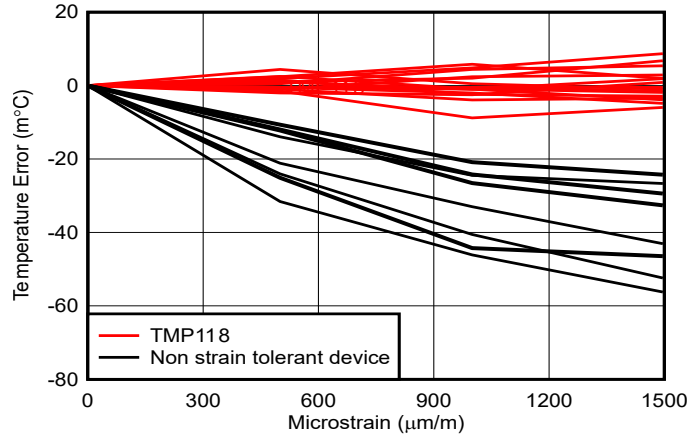

Figure 7-6. Temperature Error vs. Strain

7.3.5 NIST Traceability

The TMP118 offers a 48-bit unique ID, stored across 3 separate registers, to support NIST traceability. These unique IDs can be used to provide an audit trail to standards provided by the National Institute of Standards and Technology (NIST), a US Commerce Department agency. For information on NIST traceability for TI temperature sensors please refer to [NIST Traceability for Temperature and Humidity Sensors \(SBAT024\)](#).

NIST documentation for TI's temperature and humidity sensors is available upon request, and the documentation can be requested using the [NIST request form](#).

Reading the Unique ID registers requires a specific procedure to retrieve the content from the memory. The procedure is as follows:

1. Place the device in Shutdown Mode by setting bit 8 of Register 01h to 1b.

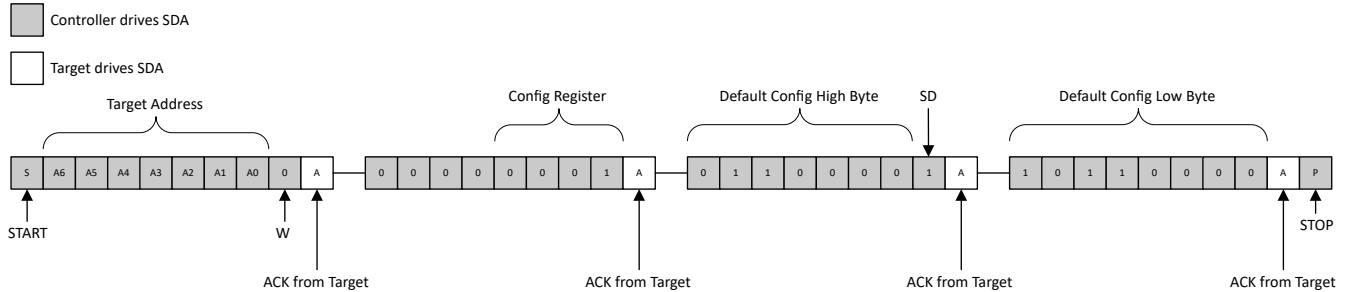

Figure 7-7. Putting Device Into Shutdown (SD) Mode

2. Write 0x0000 to the desired Unique ID pointer address (0Ch, 0Dh, or 0Eh).

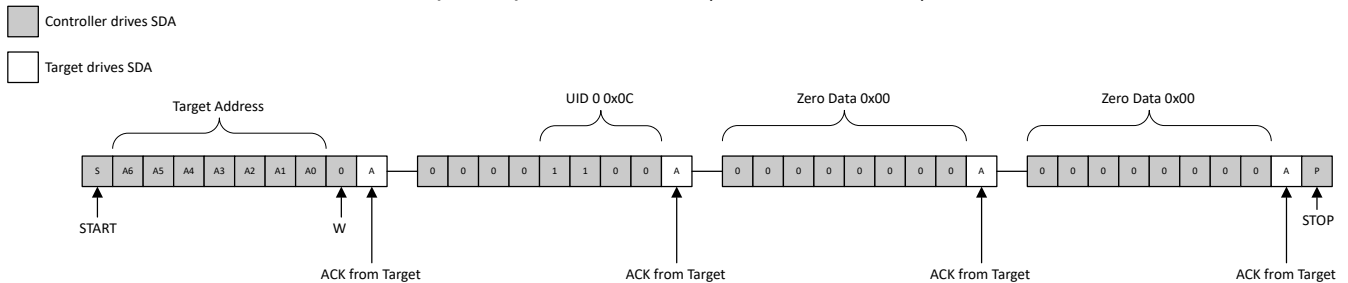

Figure 7-8. Writing 0x0000 to Unique ID 0 (UID 0)

3. Read the Unique ID from the same pointer address.

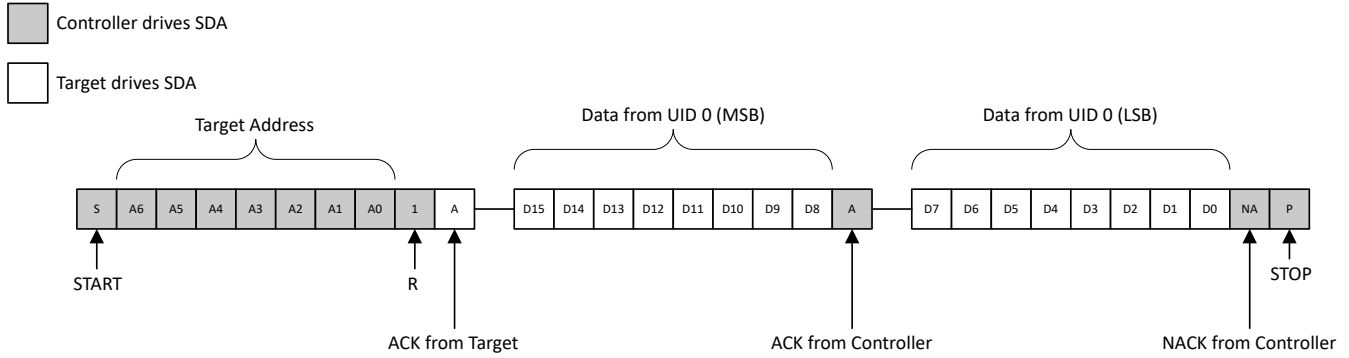

Figure 7-9. Reading Content From UID 0

4. Repeat step 2 for each pointer address, as desired.

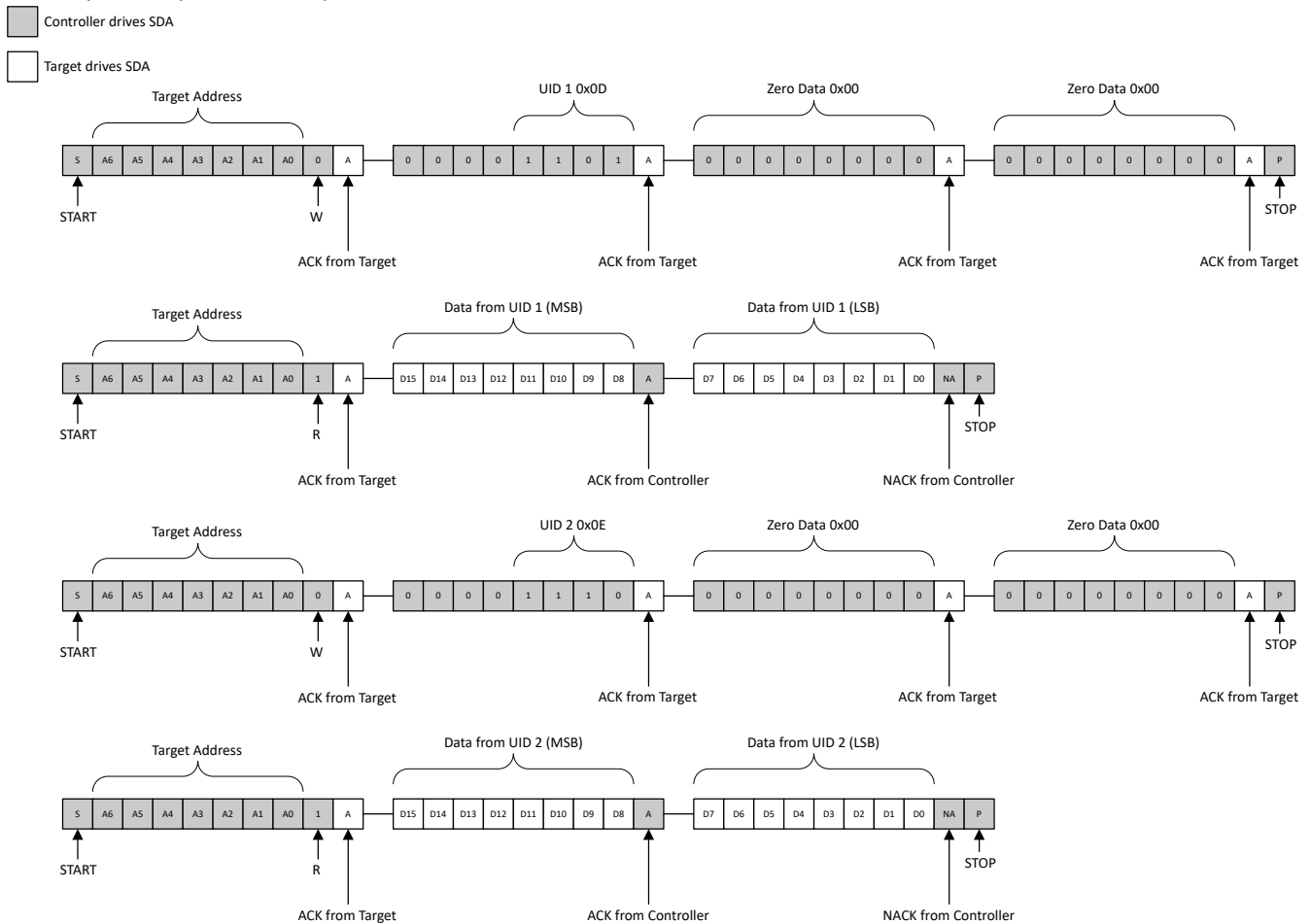

Figure 7-10. Continuing Reading Content From UID 1 and UID 2

7.4 Device Functional Modes

The TMP118 can be configured to operate in continuous or shutdown mode. This flexibility enables designers to balance the requirements of power efficiency and performance.

7.4.1 Continuous Conversion Mode

When the Shutdown bit is set to 0b in the configuration register, the device operates in continuous conversion mode. Figure 7-11 shows the device in a continuous conversion cycle. In this mode, the device performs

conversion at fixed intervals and updates the temperature result register at the end of every conversion, The typical active conversion time is 11ms (with no averaging).

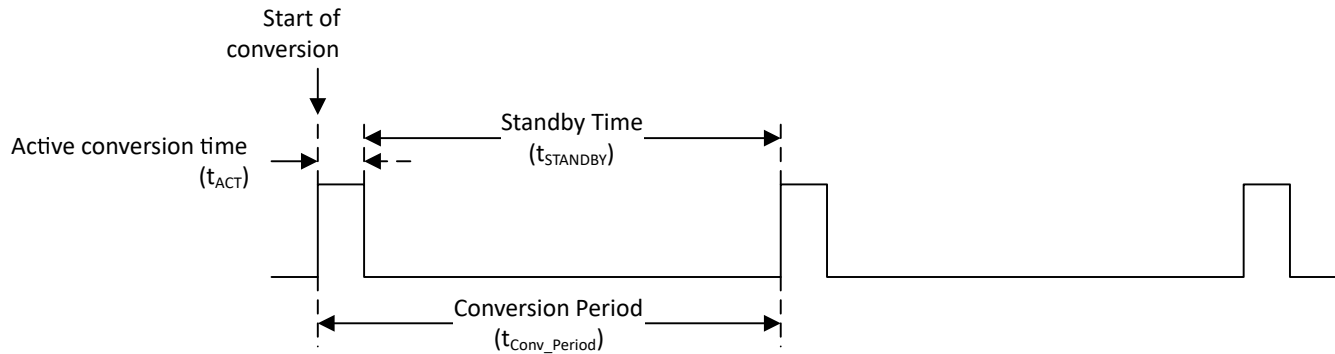

Figure 7-11. Continuous Conversion Cycle Timing Diagram

The Conversion_Rate[1:0] bits in the configuration register controls the rate at which the conversions are performed. The device typically consumes 55 μ A during conversion and 750nA during the low power standby period. By decreasing the rate at which conversions are performed, the application can benefit from reduced average current consumption in continuous mode.

Use [Equation 1](#) to calculate the average current in continuous mode.

$$\text{Average Current} = ((I_{DD_ACTIVE} \times t_{ACT}) + (I_{DD_SB} \times t_{STANDBY})) / t_{Conv_Period} \quad (1)$$

Where

- t_{ACT} = Active conversion time
- t_{Conv_Period} = Conversion Period
- $t_{STANDBY}$ = Standby time between conversions calculated as $t_{Conv_Period} - t_{ACT}$

7.4.2 One-Shot Mode (OS)

The TMP118 features a one-shot temperature-measurement mode. When the device is in shutdown mode (bit Shutdown= 1b in the [Configuration Register](#)), writing 1b to both the OS and Shutdown bits in the [Configuration Register](#) begins a single temperature conversion, which typically takes 12ms. During the conversion, the OS bit reads 0b. The device returns to the shutdown state at the completion of the single conversion. After the conversion, the OS bit reads 1b. To trigger another one-short temperature conversion, write 1b to both the OS and Shutdown bits again in the [Configuration Register](#). This feature is useful for reducing power consumption in the device when continuous temperature monitoring is not required.

In Continuous Conversion Mode (bit Shutdown= 0b in the [Configuration Register](#)), the OS bit always reads 0b.

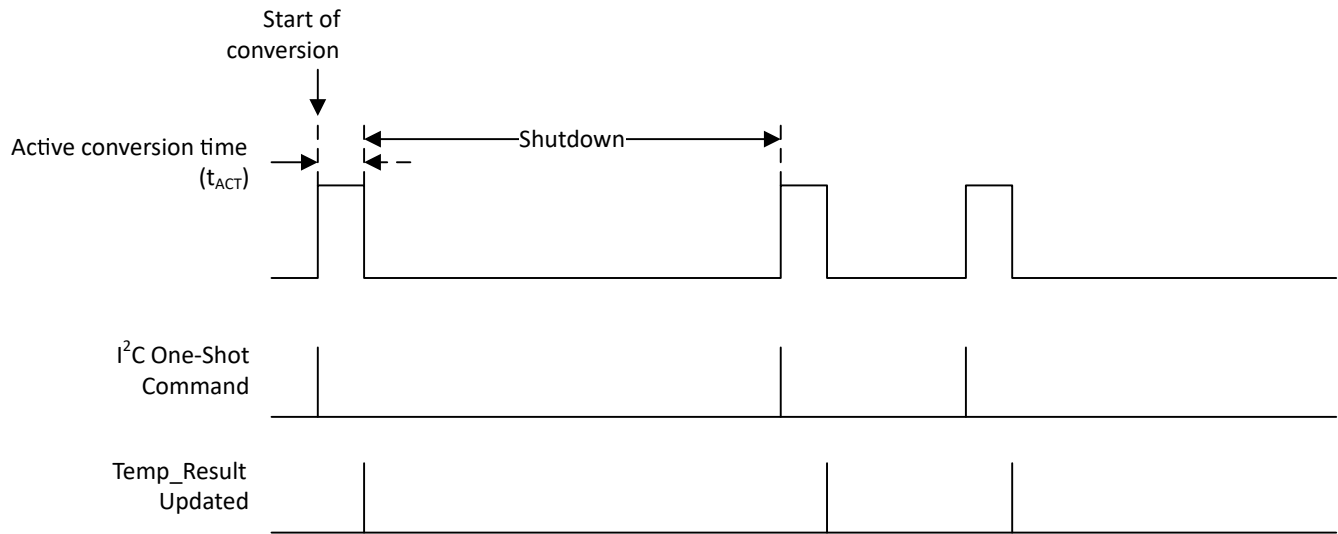

Figure 7-12. One-Shot Timing Diagram

7.5 Programming

7.5.1 I²C and SMBus Interface

7.5.1.1 Serial Interface

The TMP118 has a standard bidirectional I²C interface that is controlled by a controller device. Each target on the I²C bus has a specific device address to differentiate between other target devices that are on the same I²C bus. Many target devices require configuration upon start-up to set the behavior of the device. This is typically done when the controller accesses internal register maps of the target, which have unique register pointers. The TMP118 supports transmission data rates up to 1MHz.

7.5.1.1.1 Bus Overview

The physical I²C interface consists of the serial clock (SCL) and serial data (SDA) lines. Both SDA and SCL lines must be connected to a supply through an external pullup resistor (unless integrated within the controller). The size of the pullup resistor is determined by the amount of capacitance on the I²C lines, the pullup bus voltage, and the communication frequency. For further details, see the [I²C Pullup Resistor Calculation](#) application note. Data transfer can be initiated only when the bus is idle. A bus is considered idle if both SDA and SCL lines are high after a STOP condition.

I²C communication with this device is initiated by the controller sending a START condition and terminated by the controller sending a STOP condition. A high-to-low transition on the SDA line while the SCL is high defines a START condition. A low-to-high transition on the SDA line while the SCL is high defines a STOP condition.

A repeated START condition is similar to a START condition and is used in place of a back-to-back STOP then START condition. A repeated START condition looks identical to a START condition, but differs from a START condition because the condition occurs without a STOP condition (when the bus is not idle).

Table 7-4. Device Address Options

DEVICE	7-BIT I ² C TARGET ADDRESS	
	HEX	BINARY
TMP118A/ TMP118MA	0x48	1001000'b
TMP118B/ TMP118MB	0x49	1001001'b
TMP118C/ TMP118MC	0x4A	1001010'b
TMP118D/ TMP118MD	0x4B	1001011'b

7.5.1.1.3 Writing and Reading Operation

7.5.1.1.3.1 Writes

To write on the I²C bus, the controller sends a START condition on the bus with the address of the target, as well as the last bit (the R/W bit) set to 0b, which signifies a write. The target acknowledges, letting the controller know the target is present on the bus and ready. After this, the controller starts sending the register pointer and register data to the target until the controller has sent all the data necessary, and the controller terminates the transmission with a STOP condition.

Writes to read-only registers or register locations outside of the register map are ignored. The TMP118 still acknowledges (ACK) when writing outside of the register map. Figure 7-15 shows an example of writing 2-byte data to a single register.

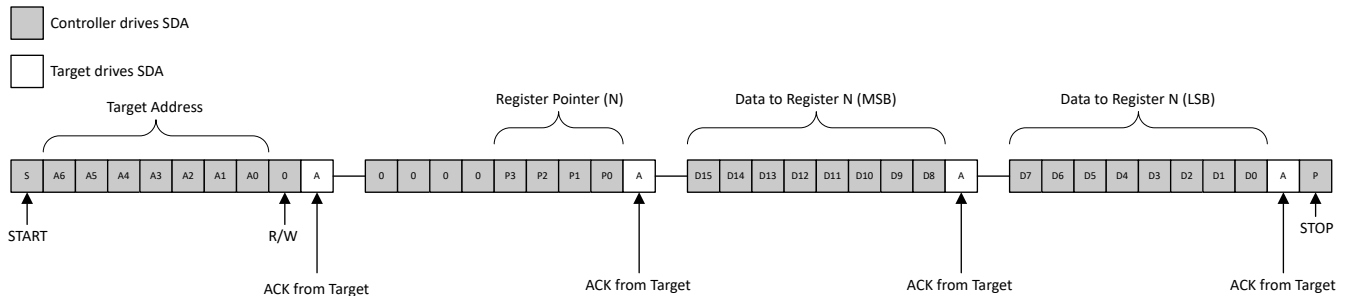

Figure 7-15. Write to Single Register

7.5.1.1.3.2 Reads

For a read operation the controller sends a START condition, followed by the target address with the R/W bit set to 0b (signifying a write). The target acknowledges the write request, and the controller then sends the register pointer in the next frame. The controller then initiates a START or RESTART followed by the target address with the R/W bit set to 1b (signifying a read). A START initiates communication with an target, while a RESTART allows the controller to access different registers on the same target without needing to send a full STOP signal first. The controller continues to send out clock pulses but releases the SDA line so that the target can transmit data. At the end of every byte of data, the controller sends an ACK to the target, letting the target know that the controller is ready for more data. Once the controller has received the number of bytes the controller is expecting, the controller sends a NACK, signaling to the target to halt communications and release the SDA line. The controller follows this up with a STOP condition.

Note that:

- If the controller needs to read from the same register repeatedly, the controller is not required to resend the pointer over and over again. The pointer value is stored in the device.
- The default pointer value upon device POR is 0h, so the controller can immediately proceed to read the temperature result after device power-up without sending the pointer value for the Temp_Result register.
- Reading from a non-indexed register location returns 0x0h.

Figure 7-16 shows an example of reading a single word from a target register.

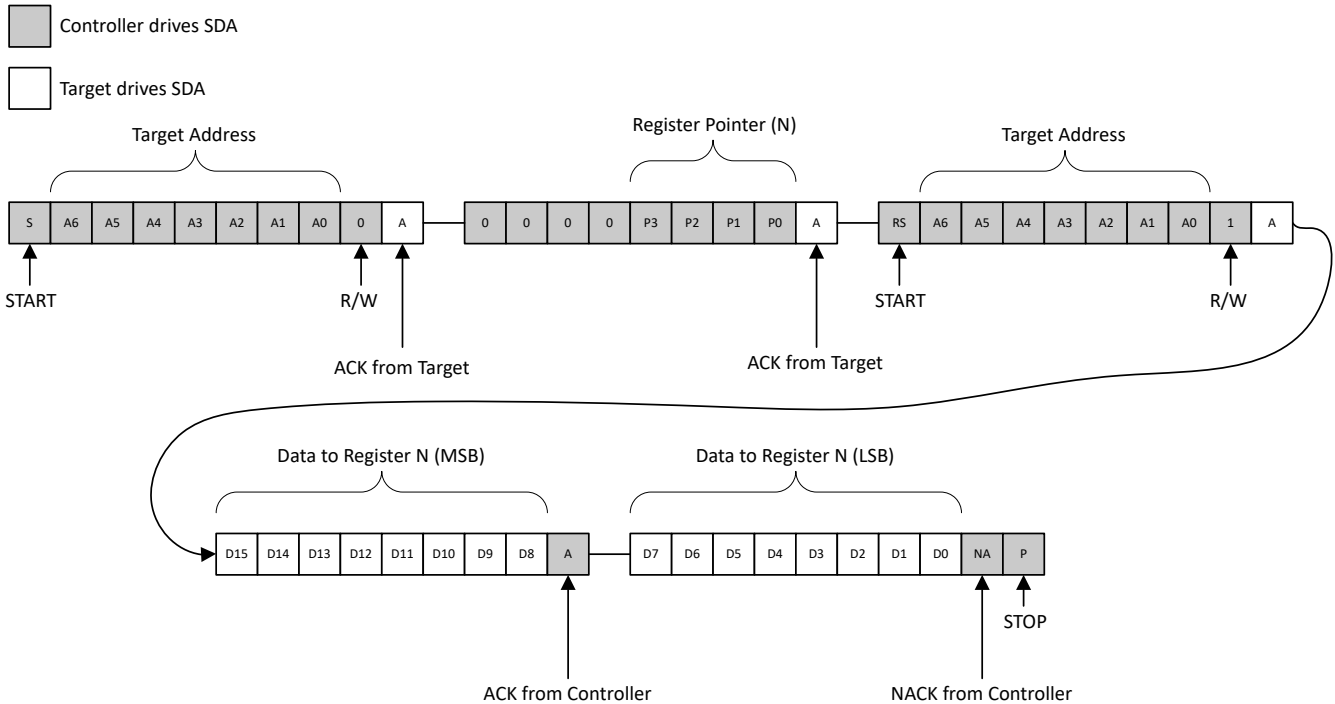

Figure 7-16. Read from Single Register

7.5.1.1.4 General-Call Reset Function

A "General-Call Reset Function" in SMBus refers to a mechanism where a controller can send a signal to all target devices on the bus simultaneously, essentially initiating a reset operation on every connected device by broadcasting a special address known as the "General Call Address" instead of addressing to a specific target address. The feature allows for a coordinated reset across all devices on the bus, often used for system-wide initialization or error recovery scenarios.

The TMP118 responds to a two-wire, general-call address (0000000b) if the eighth bit is 0b. The device acknowledges the general-call address and responds to commands in the second byte. If the second byte is 00000110b or 06h, the TMP118 internal registers are reset to power-up values as shown in Figure 7-17.

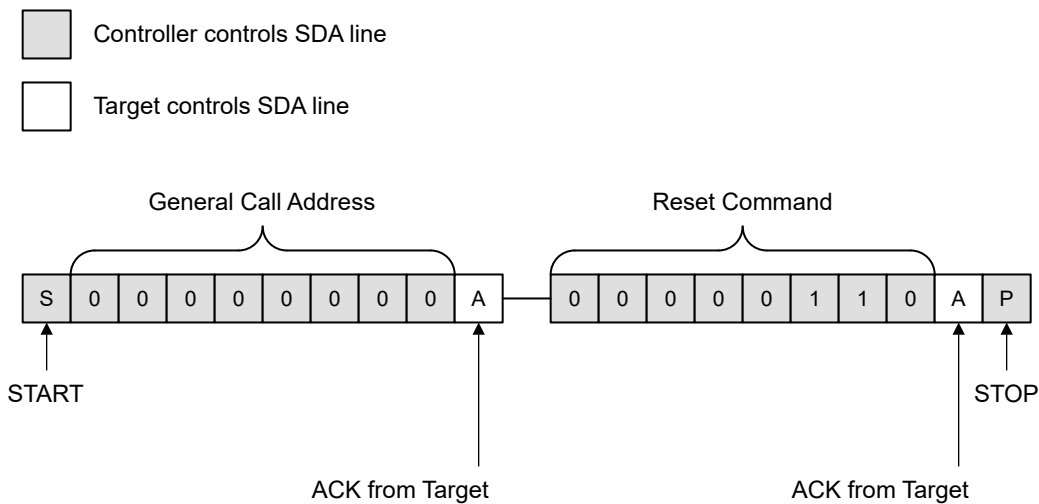

Figure 7-17. SMBus General Call Reset Diagram

7.5.1.1.5 Timeout Function

The TMP118 resets the internal serial interface if the SCL line is held low by the controller or the SDA line is held low by the TMP118 for longer than 30ms (typical) between a START and STOP condition. The TMP118 releases the SDA line if the SCL pin is pulled low and waits for a START condition from the controller. To avoid activating the timeout function, maintain a communication speed of at least 1kHz for the SCL operating frequency.

7.5.1.1.6 Coexistence on I3C Mixed Bus

A bus with both I3C and I²C interfaces is referred to as a mixed bus with clock speeds up to 12.5MHz. The TMP118 is an I²C device that can be on the same bus that has an I3C device attached as the device incorporates a spike suppression filter of 50ns on the SDA and SCL pins to filter out any communication above 4Mhz. The filter helps avoid any interference to the bus when I3C communication takes place on the bus. I²C bus targets (with 50ns filter) can coexist with I3C controllers operating at 12.5MHz, enabling the migration of existing I²C bus designs to the I3C specification.

8 Device Registers

8.1 Register Map

Table 8-1. TMP118 Register Map

POINTER	TYPE	RESET	ACRONYM	REGISTER NAME	SECTION
0h (default pointer)	R	0000h	Temp_Result	Temperature Register	Go
1h	R/W	60B0h	Configuration	Configuration Register	Go
2h	R/W	2580h	TLow_Limit	Temperature Low Limit	Go
3h	R/W	2800h	THigh_Limit	Temperature High Limit	Go
Bh	R	1180h	Device_ID	Device ID	Go
Ch	R	xxxxh	Unique_ID0	NIST Data 0 Register	Go
Dh	R	xxxxh	Unique_ID1	NIST Data 1 Register	Go
Eh	R	xxxxh	Unique_ID2	NIST Data 2 Register	Go

Table 8-2. TMP118 Register Section/Block Access Type Codes

Access Type	Code	Description
Read Type		
R	R	Read
RC	R C	Read to Clear
R-0	R -0	Read Returns 0s
Write Type		
W	W	Write
W0CP	W 0C P	W 0 to clear Requires privileged access
Reset or Default Value		
-n		Value after reset or the default value

8.1.1 Temp_Result Register (address = 00h) [reset = 0000h]

This register stores the latest temperature conversion result in a 16-bit two's complement format with a LSB equal to 0.0078125 °C.

Return to [Register Map](#).

Table 8-3. Temp_Result Register

15	14	13	12	11	10	9	8
Temp_Result[15:8]							
R-00h							
7	6	5	4	3	2	1	0
Temp_Result[7:0]							
R-00h							

Table 8-4. Temp_Result Register Field Description

Bit	Field	Type	Reset	Description
15:0	Temp_Result[15:0]	R	0000h	16-bit temperature conversion result Temperature data is represented by a 16-bit, two's complement word with an LSB equal to 0.0078125 °C.

8.1.2 Configuration Register (address = 01h) [reset = 60B0h]

This register is used to configure the operation of the TMP118 and also provides the alert status.

Return to [Register Map](#).

Table 8-5. Configuration Register

15	14	13	12	11	10	9	8
One_Shot	Reserved		Fault[1:0]		Polarity	Reserved	Shutdown
R/W-0b	R-11b		R/W-00b		R/W-0b	R-0b	R/W-0b
7	6	5	4	3	2	1	0
Conversion_Rate[1:0]		Alert	Reserved	AVG[1:0]		Reserved	
R/W-10b		R-1b	R-1b	R/W-00b		R-00b	

Table 8-6. Configuration Register Field Description

Bit	Field	Type	Reset	Description
15	One_Shot	R/W	0b	One-shot conversion trigger applicable in shutdown mode only. In continuous conversion mode the bit reads 0b. Writing a 1 to this bit triggers a single temperature conversion. During the conversion, this bit reads 0. The device returns to the shutdown state at the completion of the single conversion. 0b = Active conversion ongoing 1b = Trigger a one-shot conversion by writing this bit to 1b
14:13	Reserved	R	11b	Reserved
12:11	Fault[1:0]	R/W	00b	The fault bit is used to count the number of consecutive conversions for which the alert condition exists before the status bit is set. 00b = 1 fault 01b = 2 faults 10b = 4 faults 11b = 6 faults
10	Polarity	R/W	0b	The polarity bit allows the host to adjust the polarity of the Alert_Flag bit. 0b = Alert_Flag is active low 1b = Alert_Flag is active high
9	Reserved	R	0b	Reserved. Program the value to 0b.
8	Shutdown	R/W	0b	The shutdown bit is used to change the device conversion mode. 0b = Continuous conversion mode 1b = Shutdown mode
7:6	Conversion_Rate[1:0]	R/W	10b	The conversion rate bits configure the device conversion interval. The default is conversion every 250ms. 00b = 4s / 0.25Hz 01b = 1s / 1Hz 10b = 0.25s / 4Hz 11b = 125ms / 8Hz
5	Alert_Flag	R	1b	The Alert_Flag bit is a read-only bit which provides the information about the alert status. The Polarity bit affects the Alert_Flag value.
4	Reserved	R	1b	Reserved

Table 8-6. Configuration Register Field Description (continued)

Bit	Field	Type	Reset	Description
3:2	AVG[1:0]	R/W	00b	Averaging enable bit. Averaging forces every measurement including one-shot measurements to be averaged with the following conversions modes: 00b = No Averaging 01b = 4x Back-to-back Averaging 10b = 8x Back-to-back Averaging 11b = Moving 4x Averaging
1:0	Reserved	R	00b	Reserved.

8.1.3 TLow_Limit Register (address = 02h) [reset = 2580h]

This register is used to configure the low temperature comparator threshold of the device. The limit is formatted in a 16-bit two's complement format with a LSB (Least Significant Bit) equal to 0.0078125 °C. The default value on start-up is 2580h or 75 °C.

Return to [Register Map](#).

Table 8-7. THigh_Limit Register

15	14	13	12	11	10	9	8
TLow_Limit[15:8]							
R/W-25h							
7	6	5	4	3	2	1	0
TLow_Limit[7:0]							
R/W-80h							

Table 8-8. THigh_Limit Register Field Description

Bit	Field	Type	Reset	Description
15:0	TLow_Limit[15:0]	R/W	2580h	16-bit temperature low limit setting to be used to program the temperature comparator hysteresis. Temperature low limit is represented by a 16-bit, two's complement word with an LSB equal to 0.0078125 °C. The default setting for this is 75 °C.

8.1.4 THigh_Limit Register (address = 03h) [reset = 2800h]

This register is used to configure the high temperature comparator threshold of the device. The limit is formatted in a 16-bit two's complement format with a LSB (Least Significant Bit) equal to 0.0078125 °C. The default value on start-up is 2800h or 80 °C.

Return to [Register Map](#).

Table 8-9. THigh_Limit Register

15	14	13	12	11	10	9	8
THigh_Limit[15:8]							
R/W-28h							
7	6	5	4	3	2	1	0
THigh_Limit[7:0]							
R/W-00h							

Table 8-10. THigh_Limit Register Field Description

Bit	Field	Type	Reset	Description
15:0	THigh_Limit[15:0]	R/W	2800h	16-bit temperature high limit setting. Temperature high limit is represented by a 16-bit, two's complement word with an LSB equal to 0.0078125 °C. The default setting for this is 80 °C.

8.1.5 Device ID Register (Address = 0Bh) [reset = 1180h]

This read-only register indicates the device ID and revision number.

Return to [Register Map](#).

Table 8-11. Device_ID Register

15	14	13	12	11	10	9	8
DID[11:4]							
R-11h							
7	6	5	4	3	2	1	0
DID[3:0]				Rev[3:0]			
R-8h				R-0h			

Table 8-12. Device_ID Register Field Description

Bit	Field	Type	Reset	Description
15:4	DID[11:0]	R	118h	Indicates the device ID.
3:0	Rev[3:0]	R	0h	Indicates the revision number.

8.1.6 Unique_ID0 Register (Address = 0Ch) [reset = xxxh]

This register contains the value of the first Unique ID for the device. The Unique ID of the device is used for NIST traceability purposes.

Reading the Unique ID registers requires a specific procedure to retrieve the content from the memory. Follow the procedure described in [Section 7.3.5](#).

Return to [Register Map](#).

Table 8-13. Unique_ID0 Register

15	14	13	12	11	10	9	8
Unique_ID0[15:8]							
R-xxh							
7	6	5	4	3	2	1	0
Unique_ID0[7:0]							
R-xxh							

Table 8-14. Unique_ID0 Register Field Description

Bit	Field	Type	Reset	Description
15:0	Unique_ID0[15:0]	R	xxxh	Unique ID register 0 content

8.1.7 Unique_ID1 Register (Address = 0Dh) [reset = xxxh]

This register contains the value of the second Unique ID for the device. The Unique ID of the device is used for NIST traceability purposes.

Reading the Unique ID registers requires a specific procedure to retrieve the content from the memory. Follow the produce described in [Section 7.3.5](#).

Return to [Register Map](#).

Table 8-15. Unique_ID1 Register

15	14	13	12	11	10	9	8
Unique_ID1[15:8]							

Table 8-15. Unique_ID1 Register (continued)

R-xxh							
7	6	5	4	3	2	1	0
Unique_ID1[7:0]							
R-xxh							

Table 8-16. Unique_ID1 Register Field Description

Bit	Field	Type	Reset	Description
15:0	Unique_ID1[15:0]	R	xxxxh	Unique ID register 1 content

8.1.8 Unique_ID2 Register (Address = 0Eh) [reset = xxxxh]

This register contains the value of the third Unique ID for the device. The Unique ID of the device is used for NIST traceability purposes.

Reading the Unique ID registers requires a specific procedure to retrieve the content from the memory. Follow the procedure described in [Section 7.3.5](#).

Return to [Register Map](#).

Table 8-17. Unique_ID2 Register

15	14	13	12	11	10	9	8
Unique_ID2[15:8]							
R-xxh							
7	6	5	4	3	2	1	0
Unique_ID2[7:0]							
R-xxh							

Table 8-18. Unique_ID2 Register Field Description

Bit	Field	Type	Reset	Description
15:0	Unique_ID2[15:0]	R	xxxxh	Unique ID register 2 content

9 Application and Implementation

Note

Information in the following applications sections is not part of the TI component specification, and TI does not warrant its accuracy or completeness. TI's customers are responsible for determining suitability of components for their purposes, as well as validating and testing their design implementation to confirm system functionality.

9.1 Application Information

The TMP118 is used to measure the temperature of the mounting location. The different address options allow four TMP118 sensors on a single serial bus. For more information, refer to the related [Considerations for Measuring Ambient Air Temperature](#), [Replacing resistance temperature detectors with the TMP116 temp sensor](#), and [Temperature sensors: PCB guidelines for surface mount devices](#) application notes on ti.com.

9.2 Typical Application

9.2.1 Separate I²C Pullup and Supply Application

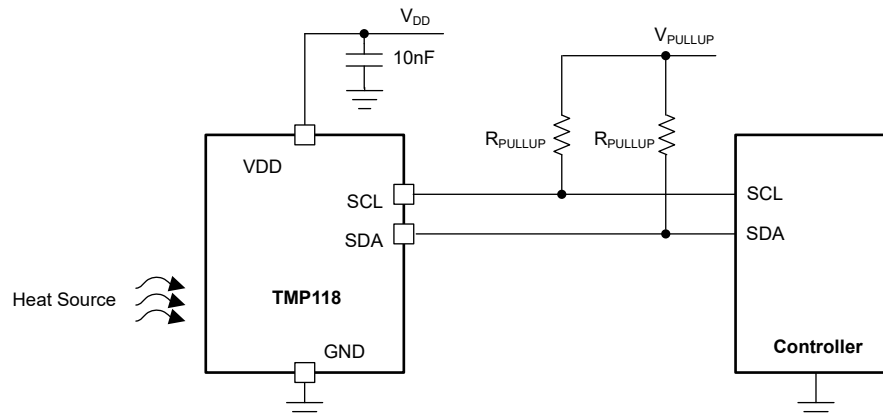

Figure 9-1. Separate I2C Pullup and Supply Voltage Application

9.2.1.1 Design Requirements

For this design example, use the parameters listed below.

Table 9-1. Design Parameters

PARAMETER	VALUE
Supply (V_{DD})	1.4V to 5.5V
V_{PULLUP}	1.2V
R_{PULLUP}	$V_{PULLUP} / 1\text{mA}$

9.2.1.2 Detailed Design Procedure

The TMP118 converts temperature at fixed intervals in continuous conversion mode. The SDA and SCL pin voltage of the TMP118 can be at a different voltage than the V_{DD} pin voltage, removing the need for power sequencing when using the TMP118. The I/O current is rated up to 2mA. The pullup resistors can be selected such that the I/O current is below the I/O current (1mA in this design example).

The TMP118 is a very small package with low thermal mass and can be placed as close to the temperature source as possible for better thermal coupling.

9.2.2 Equal I²C Pullup and Supply Voltage Application

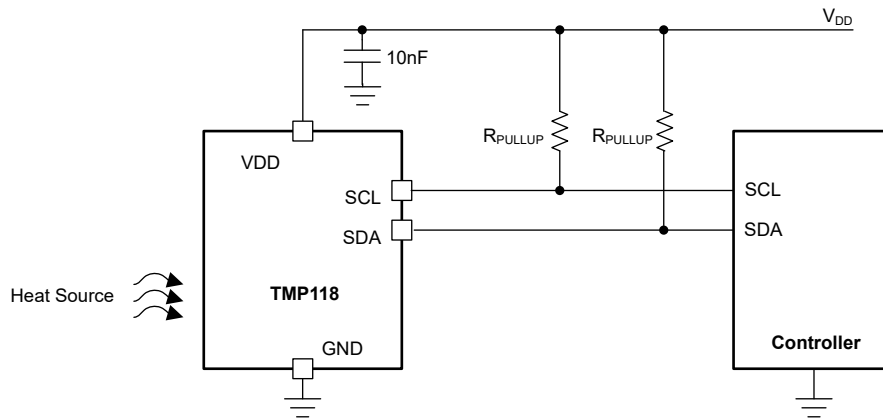

Figure 9-2. Equal I²C Pullup and Supply Voltage Application

9.2.2.1 Design Requirements

For this design example, use the parameters listed below.

Table 9-2. Design Parameters

PARAMETER	VALUE
Supply (V_{DD})	1.4V to 5.5V
V_{PULLUP}	V_{DD}
R_{PULLUP}	$V_{DD} / 1mA$

9.2.2.2 Detailed Design Procedure

The SDA and SCL pin voltage of the TMP118 can be the same as the supply voltage V_{DD} . The accuracy of the device is not affected by the pullup voltage. The I/O current is rated up to 2mA. The pullup resistors must be selected such that the I/O current is below the I/O current (1mA in this design example).

9.3 Power Supply Recommendations

9.4 Layout

9.4.1 Layout Guidelines

The TMP118 is a simple device to layout. Place the power-supply bypass capacitor as close as possible to the supply and ground pins. The recommended value of this bypass capacitor is 10nF. Pull up the open-drain output pin SDA and the I²C clock SCL through R_{PULLUP} pullup resistors. In some cases, the pullup resistor can be the heat source, therefore, maintain some distance between the resistor and the device. Ideally, the pullup resistors should be placed near the controller's I²C SDA/SCL lines. Place the TMP118 as far away as possible from light sources as excessive light exposure can affect the device's measurement accuracy and current consumption.

For systems reliant on fast response times, it is recommended to use a Flexible Printed Circuit (FPC) board to extract the best response time from the TMP118. See [Improving the Response Time of the TMP118](#) for more information on the benefits of using an FPC board. The [TMP118EVM](#) also features the TMP118 temperature

sensor on an FPC board to demonstrate the device's competitive response time and can be ordered for evaluation.

For more information on board layout, refer to the related [Precise temperature measurements with TMP116 and TMP117](#) and [Wearable temperature-sensing layout considerations optimized for thermal response](#) application notes on ti.com. The following sections provide additional guidelines on board layout:

1. If the device is used to measure PCB temperature:
 - Use PCB with minimal thickness.
 - Prevent PCB bending which can create a mechanical stress to package.
 - Cover bottom of the PCB with copper plane.
2. If the device is used to measure ambient air temperature (moving or still air):
 - Use a PCB with thicker copper layers if possible.
 - Place PCB vertically along air to increase air contact surface area and reduce dust collection
 - Miniaturize the board to reduce thermal mass. Smaller thermal mass results in faster thermal response.
 - Thermal isolation is required to avoid thermal coupling from heat source components through the PCB.
 - Avoid running the copper plane underneath the temperature sensor.
 - Maximize the air gap between the sensor and the surrounding copper areas (anti-etch), especially when close to the heat source.
 - Create a PCB cutout between sensor and other circuits.
 - If the heat source is top side, avoid running traces on top; instead, route all signals on the bottom side.
3. If designing the TMP118 on an Flexible Printed Circuit (FPC) board:
 - a. Ensure the vendor has the capabilities to create a footprint for a 0.3 mm pitch device, and if possible, use Flex Solder Mask to prevent any possible layout issues which may result from conventional solder mask.
 - b. If the board will be subject to physical torque from bending, it is highly recommended to add stiffener to the layer under the TMP118 to ensure structural integrity of solder joints.

9.4.2 Layout Examples

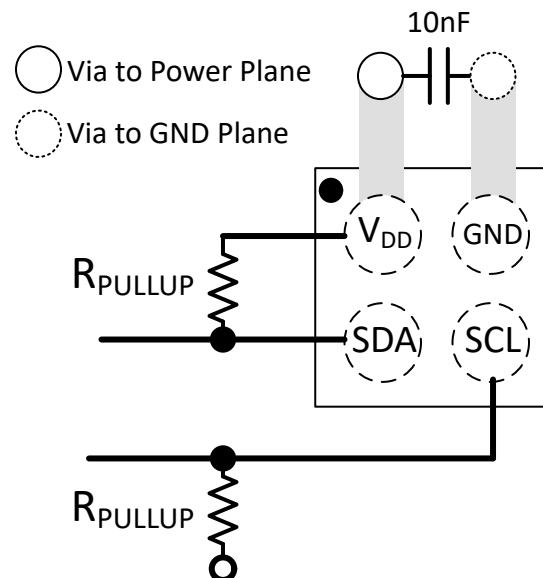

Figure 9-3. YMS Layout Recommendation

10 Device and Documentation Support

10.1 Documentation Support

10.1.1 Related Documentation

For related documentation see the following:

- Texas Instruments, [Design Considerations for Measuring Ambient Air Temperature](#) application note
- Texas Instruments, [How to Read and Interpret Digital Temperature Sensor Output Data](#) application note
- Texas Instruments, [Low-Power Design Techniques for Temperature-Sensing Applications](#) application note
- Texas Instruments, [Replacing Resistance Temperature Detectors With the TMP116 Temp Sensor](#) application note
- Texas Instruments, [Temperature Sensors: PCB Guidelines for Surface Mount Devices](#) application note
- Texas Instruments, [Precise Temperature Measurements With TMP116 and TMP117](#) application note
- Texas Instruments, [Wearable Temperature-sensing Layout Considerations Optimized for Thermal Response](#) application note
- Texas Instruments, [NIST Traceability for Temperature and Humidity Sensors](#)

10.2 Receiving Notification of Documentation Updates

To receive notification of documentation updates, navigate to the device product folder on ti.com. Click on *Notifications* to register and receive a weekly digest of any product information that has changed. For change details, review the revision history included in any revised document.

10.3 Support Resources

[TI E2E™ support forums](#) are an engineer's go-to source for fast, verified answers and design help — straight from the experts. Search existing answers or ask your own question to get the quick design help you need.

Linked content is provided "AS IS" by the respective contributors. They do not constitute TI specifications and do not necessarily reflect TI's views; see TI's [Terms of Use](#).

10.4 Trademarks

TI E2E™ is a trademark of Texas Instruments.

All trademarks are the property of their respective owners.

10.5 Electrostatic Discharge Caution



This integrated circuit can be damaged by ESD. Texas Instruments recommends that all integrated circuits be handled with appropriate precautions. Failure to observe proper handling and installation procedures can cause damage.

ESD damage can range from subtle performance degradation to complete device failure. Precision integrated circuits may be more susceptible to damage because very small parametric changes could cause the device not to meet its published specifications.

10.6 Glossary

[TI Glossary](#) This glossary lists and explains terms, acronyms, and definitions.

11 Revision History

NOTE: Page numbers for previous revisions may differ from page numbers in the current version.

Changes from Revision * (December 2024) to Revision A (April 2025)	Page
• Updated the numbering format for tables, figures, and cross-references throughout the document.....	1
• Updated thermal mass to 0.092 mJ/°C from 0.14mJ/°C.....	6
• Added additional specification for 0°C to 50°C for TMP118.....	7
• Added additional specification for 10°C to 50°C for TMP118M.....	7
• Updated the ±0.2°C accuracy specification temperature range to –20°C to 85°C from 0°C to 85°C.....	7
• Added additional specification for -20°C to 85°C for TMP118M from V _{DD} = 1.4V to 5.5V.....	7
• Changed maximum active current over temperature and supply to 100µA from 95µA.....	7

- Removed the max spec for Data Hold Time.....9
- Updated the TLow_Limit to 16-bit format from 12-bit format.....28
- Updated the THigh_Limit to 16-bit format from 12-bit format.....28

12 Mechanical, Packaging, and Orderable Information

The following pages include mechanical, packaging, and orderable information. This information is the most current data available for the designated devices. This data is subject to change without notice and revision of this document. For browser-based versions of this data sheet, refer to the left-hand navigation.

Table 12-1. YMS Package Dimensions

	Body length (mm)	Body width (mm)	Height (mm)
MIN	0.59	0.53	0.2
NOMINAL	0.61	0.55	0.22
MAX	0.63	0.57	0.24

PACKAGING INFORMATION

Orderable part number	Status (1)	Material type (2)	Package Pins	Package qty Carrier	RoHS (3)	Lead finish/ Ball material (4)	MSL rating/ Peak reflow (5)	Op temp (°C)	Part marking (6)
TMP118AIYMSR	Active	Production	PICOSTAR (YMS) 4	12000 LARGE T&R	Yes	NIPD	Level-1-260C-UNLIM	-40 to 125	D
TMP118AIYMSR.A	Active	Production	PICOSTAR (YMS) 4	12000 LARGE T&R	Yes	NIPD	Level-1-260C-UNLIM	-40 to 125	D
TMP118BIYMSR	Active	Production	PICOSTAR (YMS) 4	12000 LARGE T&R	Yes	NIPD	Level-1-260C-UNLIM	-40 to 125	E
TMP118BIYMSR.A	Active	Production	PICOSTAR (YMS) 4	12000 LARGE T&R	Yes	NIPD	Level-1-260C-UNLIM	-40 to 125	E
TMP118CIYMSR	Active	Production	PICOSTAR (YMS) 4	12000 LARGE T&R	Yes	Call TI	Level-1-260C-UNLIM	-40 to 125	6
TMP118CIYMSR.A	Active	Production	PICOSTAR (YMS) 4	12000 LARGE T&R	Yes	Call TI	Level-1-260C-UNLIM	-40 to 125	6
TMP118DIYMSR	Active	Production	PICOSTAR (YMS) 4	12000 LARGE T&R	Yes	Call TI	Level-1-260C-UNLIM	-40 to 125	5
TMP118DIYMSR.A	Active	Production	PICOSTAR (YMS) 4	12000 LARGE T&R	Yes	Call TI	Level-1-260C-UNLIM	-40 to 125	5
TMP118MAIYMSR	Active	Production	PICOSTAR (YMS) 4	12000 LARGE T&R	Yes	NIPD	Level-1-260C-UNLIM	-25 to 85	P
TMP118MAIYMSR.A	Active	Production	PICOSTAR (YMS) 4	12000 LARGE T&R	Yes	NIPD	Level-1-260C-UNLIM	-40 to 125	P
TMP118MBIYMSR	Active	Production	PICOSTAR (YMS) 4	12000 LARGE T&R	Yes	NIPD	Level-1-260C-UNLIM	-25 to 85	Q
TMP118MBIYMSR.A	Active	Production	PICOSTAR (YMS) 4	12000 LARGE T&R	Yes	NIPD	Level-1-260C-UNLIM	-40 to 125	Q
TMP118MCIYMSR	Active	Production	PICOSTAR (YMS) 4	12000 LARGE T&R	Yes	Call TI	Level-1-260C-UNLIM	-25 to 85	W
TMP118MCIYMSR.A	Active	Production	PICOSTAR (YMS) 4	12000 LARGE T&R	Yes	Call TI	Level-1-260C-UNLIM	-40 to 125	W
TMP118MDIYMSR	Active	Production	PICOSTAR (YMS) 4	12000 LARGE T&R	Yes	Call TI	Level-1-260C-UNLIM	-25 to 85	X
TMP118MDIYMSR.A	Active	Production	PICOSTAR (YMS) 4	12000 LARGE T&R	Yes	Call TI	Level-1-260C-UNLIM	-40 to 125	X

(1) **Status:** For more details on status, see our [product life cycle](#).

(2) **Material type:** When designated, preproduction parts are prototypes/experimental devices, and are not yet approved or released for full production. Testing and final process, including without limitation quality assurance, reliability performance testing, and/or process qualification, may not yet be complete, and this item is subject to further changes or possible discontinuation. If available for ordering, purchases will be subject to an additional waiver at checkout, and are intended for early internal evaluation purposes only. These items are sold without warranties of any kind.

(3) **RoHS values:** Yes, No, RoHS Exempt. See the [TI RoHS Statement](#) for additional information and value definition.

(4) **Lead finish/Ball material:** Parts may have multiple material finish options. Finish options are separated by a vertical ruled line. Lead finish/Ball material values may wrap to two lines if the finish value exceeds the maximum column width.

(5) **MSL rating/Peak reflow:** The moisture sensitivity level ratings and peak solder (reflow) temperatures. In the event that a part has multiple moisture sensitivity ratings, only the lowest level per JEDEC standards is shown. Refer to the shipping label for the actual reflow temperature that will be used to mount the part to the printed circuit board.

(6) Part marking: There may be an additional marking, which relates to the logo, the lot trace code information, or the environmental category of the part.

Multiple part markings will be inside parentheses. Only one part marking contained in parentheses and separated by a "-" will appear on a part. If a line is indented then it is a continuation of the previous line and the two combined represent the entire part marking for that device.

Important Information and Disclaimer:The information provided on this page represents TI's knowledge and belief as of the date that it is provided. TI bases its knowledge and belief on information provided by third parties, and makes no representation or warranty as to the accuracy of such information. Efforts are underway to better integrate information from third parties. TI has taken and continues to take reasonable steps to provide representative and accurate information but may not have conducted destructive testing or chemical analysis on incoming materials and chemicals. TI and TI suppliers consider certain information to be proprietary, and thus CAS numbers and other limited information may not be available for release.

In no event shall TI's liability arising out of such information exceed the total purchase price of the TI part(s) at issue in this document sold by TI to Customer on an annual basis.

TAPE AND REEL INFORMATION

QUADRANT ASSIGNMENTS FOR PIN 1 ORIENTATION IN TAPE

*All dimensions are nominal

Device	Package Type	Package Drawing	Pins	SPQ	Reel Diameter (mm)	Reel Width W1 (mm)	A0 (mm)	B0 (mm)	K0 (mm)	P1 (mm)	W (mm)	Pin1 Quadrant
TMP118AIYMSR	PICOSTAR	YMS	4	12000	180.0	8.4	0.7	0.64	0.32	2.0	8.0	Q1
TMP118BIYMSR	PICOSTAR	YMS	4	12000	180.0	8.4	0.7	0.64	0.32	2.0	8.0	Q1
TMP118CIYMSR	PICOSTAR	YMS	4	12000	180.0	8.4	0.7	0.64	0.32	2.0	8.0	Q1
TMP118DIYMSR	PICOSTAR	YMS	4	12000	180.0	8.4	0.7	0.64	0.32	2.0	8.0	Q1
TMP118MAIYMSR	PICOSTAR	YMS	4	12000	180.0	8.4	0.7	0.64	0.32	2.0	8.0	Q1
TMP118MBIYMSR	PICOSTAR	YMS	4	12000	180.0	8.4	0.7	0.64	0.32	2.0	8.0	Q1
TMP118MCIYMSR	PICOSTAR	YMS	4	12000	180.0	8.4	0.7	0.64	0.32	2.0	8.0	Q1
TMP118MDIYMSR	PICOSTAR	YMS	4	12000	180.0	8.4	0.7	0.64	0.32	2.0	8.0	Q1

TAPE AND REEL BOX DIMENSIONS

*All dimensions are nominal

Device	Package Type	Package Drawing	Pins	SPQ	Length (mm)	Width (mm)	Height (mm)
TMP118AIYMSR	PICOSTAR	YMS	4	12000	182.0	182.0	20.0
TMP118BIYMSR	PICOSTAR	YMS	4	12000	182.0	182.0	20.0
TMP118CIYMSR	PICOSTAR	YMS	4	12000	182.0	182.0	20.0
TMP118DIYMSR	PICOSTAR	YMS	4	12000	182.0	182.0	20.0
TMP118MAIYMSR	PICOSTAR	YMS	4	12000	182.0	182.0	20.0
TMP118MBIYMSR	PICOSTAR	YMS	4	12000	182.0	182.0	20.0
TMP118MCIYMSR	PICOSTAR	YMS	4	12000	182.0	182.0	20.0
TMP118MDIYMSR	PICOSTAR	YMS	4	12000	182.0	182.0	20.0

YMS0004A



PACKAGE OUTLINE

PicoStar™ - 0.24 mm max height

PicoStar

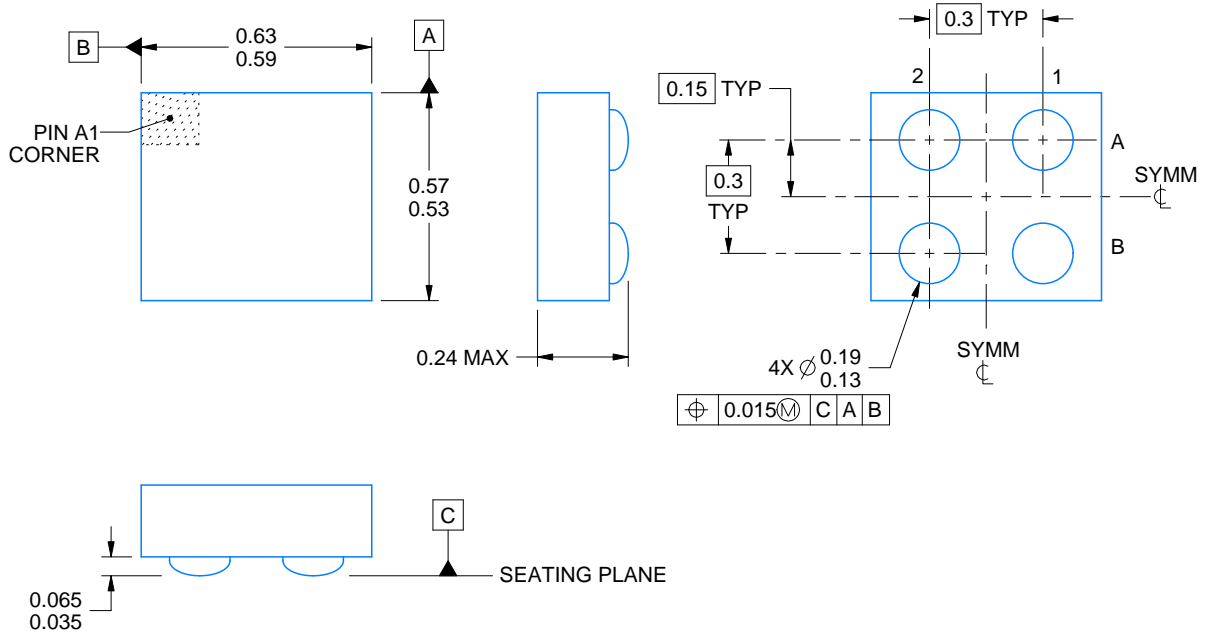

4230353/C 06/2024

NOTES:

PicoStar is a trademark of Texas Instruments.

1. All linear dimensions are in millimeters. Any dimensions in parenthesis are for reference only. Dimensioning and tolerancing per ASME Y14.5M.
2. This drawing is subject to change without notice.

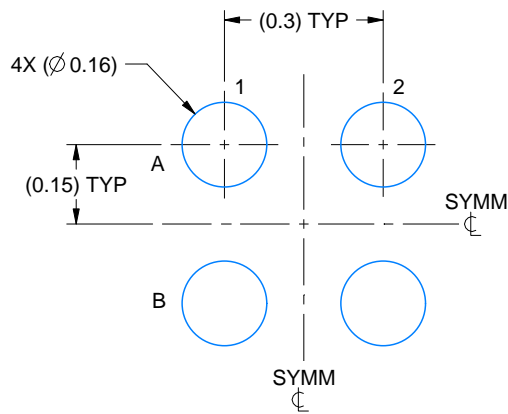

LAND PATTERN EXAMPLE
EXPOSED METAL SHOWN
SCALE:70X

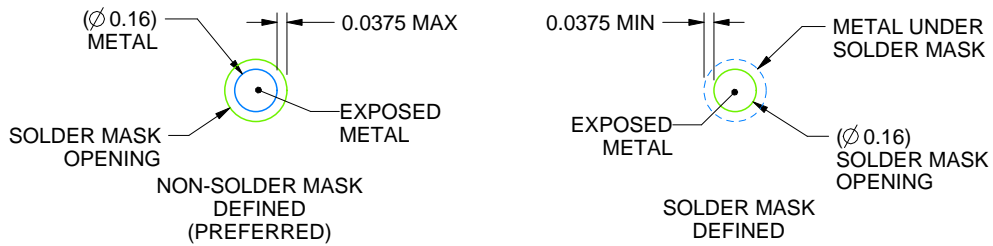

SOLDER MASK DETAILS
NOT TO SCALE

4230353/C 06/2024

NOTES: (continued)

- Final dimensions may vary due to manufacturing tolerance considerations and also routing constraints. For more information, see Texas Instruments literature number SLUA271 (www.ti.com/lit/slua271).

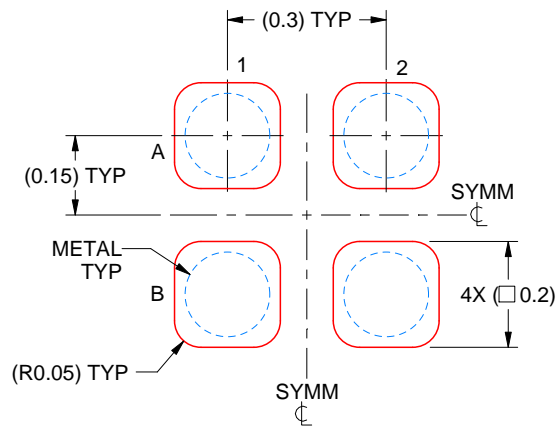

SOLDER PASTE EXAMPLE
BASED ON 0.075 mm THICK STENCIL
SCALE:70X

4230353/C 06/2024

NOTES: (continued)

4. Laser cutting apertures with trapezoidal walls and rounded corners may offer better paste release.

IMPORTANT NOTICE AND DISCLAIMER

TI PROVIDES TECHNICAL AND RELIABILITY DATA (INCLUDING DATASHEETS), DESIGN RESOURCES (INCLUDING REFERENCE DESIGNS), APPLICATION OR OTHER DESIGN ADVICE, WEB TOOLS, SAFETY INFORMATION, AND OTHER RESOURCES "AS IS" AND WITH ALL FAULTS, AND DISCLAIMS ALL WARRANTIES, EXPRESS AND IMPLIED, INCLUDING WITHOUT LIMITATION ANY IMPLIED WARRANTIES OF MERCHANTABILITY, FITNESS FOR A PARTICULAR PURPOSE OR NON-INFRINGEMENT OF THIRD PARTY INTELLECTUAL PROPERTY RIGHTS.

These resources are intended for skilled developers designing with TI products. You are solely responsible for (1) selecting the appropriate TI products for your application, (2) designing, validating and testing your application, and (3) ensuring your application meets applicable standards, and any other safety, security, regulatory or other requirements.

These resources are subject to change without notice. TI grants you permission to use these resources only for development of an application that uses the TI products described in the resource. Other reproduction and display of these resources is prohibited. No license is granted to any other TI intellectual property right or to any third party intellectual property right. TI disclaims responsibility for, and you fully indemnify TI and its representatives against any claims, damages, costs, losses, and liabilities arising out of your use of these resources.

TI's products are provided subject to [TI's Terms of Sale](#), [TI's General Quality Guidelines](#), or other applicable terms available either on [ti.com](#) or provided in conjunction with such TI products. TI's provision of these resources does not expand or otherwise alter TI's applicable warranties or warranty disclaimers for TI products. Unless TI explicitly designates a product as custom or customer-specified, TI products are standard, catalog, general purpose devices.

TI objects to and rejects any additional or different terms you may propose.

Copyright © 2026, Texas Instruments Incorporated

Last updated 10/2025