

# TPS542A50 4-V to 18-V Input, 15-A, Synchronous Buck Converter With Differential Remote Sense and I<sup>2</sup>C

## 1 Features

- Integrated 9.1-mΩ and 2.6-mΩ MOSFETs support up to 15-A output current
- 0.5-V to 5.5-V output voltage range
- Fixed-frequency voltage control mode with selectable internal compensation
- Seven selectable frequency settings from 400 kHz to 2.2 MHz
- Synchronizes to an external clock
- Fully differential remote sense
- Device configurable by analog pinstrap resistors or through I<sup>2</sup>C interface
- V<sub>OUT</sub> adjustment with controlled slew rate through I<sup>2</sup>C from –20% to +10% in 0.028% steps
- Six selectable overcurrent limits, four soft-start slew rates, and two I<sup>2</sup>C addresses
- Monotonic start-up into pre-biased outputs
- EN pin allowing for adjustable input UVLO
- Power good indicator
- 17-μA typical shutdown quiescent current draw
- Selectable FCCM or PFM for light load efficiency
- –40 to +150°C operating junction temperature
- 4-mm × 4.5-mm VQFN package
- Create a custom design using the TPS542A50 with the [WEBENCH® Power Designer](#)

## 2 Applications

- [Enterprise storage, SSD](#)
- [ASIC, SoC, FPGA, DSP core, and I/O rails](#)
- [Wired networking switches and routers](#)
- [Industrial machines and machine tools](#)

## 3 Description

The TPS542A50 is a high-efficiency synchronous buck converter with differential remote sense and I<sup>2</sup>C. This device features fixed-frequency, voltage-control mode with pinstrap selectable internal compensation for reduced system cost and complexity. The PWM can be synchronized to an external clock through the SYNC pin. Other key features include PFM for high light load efficiency, low shutdown quiescent current draw, adjustable UVLO through the EN pin and monotonic start up into pre-biased conditions. This device also features an I<sup>2</sup>C interface for device configuration and output voltage adjustment. The TPS542A50 is a lead-free device. It is fully RoHS compliant without exemption.

### Device Information

| PART NUMBER | PACKAGE <sup>(1)</sup> | BODY SIZE (NOM)   |
|-------------|------------------------|-------------------|
| TPS542A50   | VQFN (33)              | 4.50 mm × 4.00 mm |

(1) For all available packages, see the orderable addendum at the end of the data sheet.

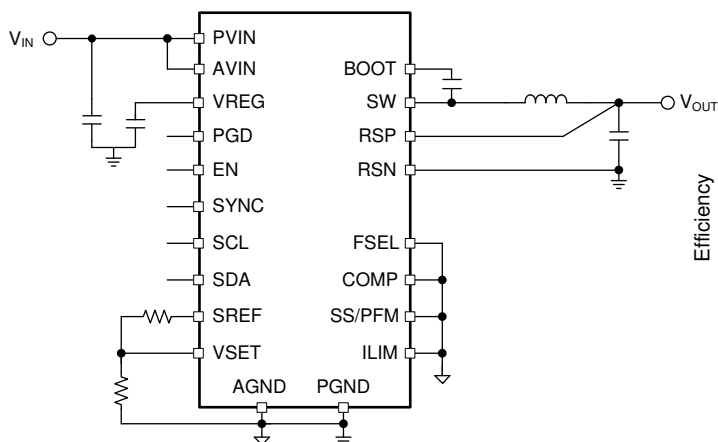

**Simplified Schematic**

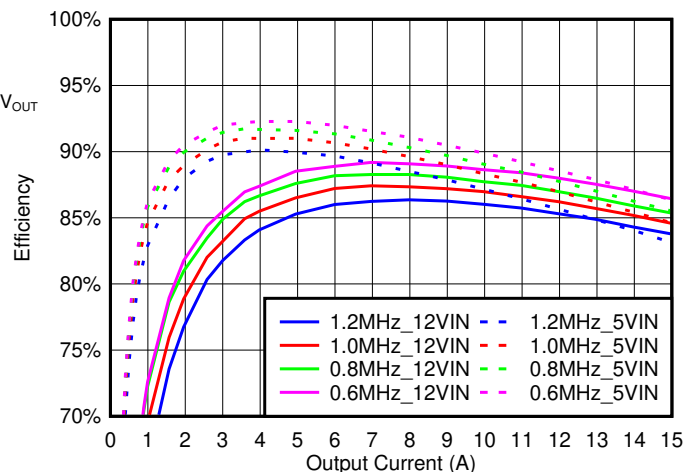

**Typical Efficiency at 1 V<sub>OUT</sub>**



## Table of Contents

|  |    |  |    |
|--|----|--|----|
| <b>1 Features</b> .....                        | 1  | 7.6 Pin-Strap Programming.....                                   | 22 |
| <b>2 Applications</b> .....                    | 1  | 7.7 Register Maps.....   | 23 |
| <b>3 Description</b> .....                     | 1  | <b>8 Application and Implementation</b> .....                    | 26 |
| <b>4 Revision History</b> .....                | 2  | 8.1 Application Information.....                                 | 26 |
| <b>5 Pin Configuration and Functions</b> ..... | 3  | 8.2 Typical Application.....                                     | 26 |
| <b>6 Specifications</b> .....                  | 4  | <b>9 Power Supply Recommendations</b> .....                      | 32 |
| 6.1 Absolute Maximum Ratings.....              | 4  | <b>10 Layout</b> .....   | 33 |
| 6.2 ESD Ratings.....                           | 4  | 10.1 Layout Guidelines.....                                      | 33 |
| 6.3 Recommended Operating Conditions.....      | 4  | 10.2 Layout Example.....   | 34 |
| 6.4 Thermal Information.....                   | 5  | <b>11 Device and Documentation Support</b> .....                 | 35 |
| 6.5 Electrical Characteristics.....            | 5  | 11.1 Device Support.....   | 35 |
| 6.6 Typical Characteristics.....               | 9  | 11.2 Receiving Notification of Documentation Updates..           | 35 |
| <b>7 Detailed Description</b> .....            | 14 | 11.3 Support Resources.....                                      | 35 |
| 7.1 Overview.....                              | 14 | 11.4 Trademarks.....   | 35 |
| 7.2 Functional Block Diagram.....              | 14 | 11.5 Electrostatic Discharge Caution.....                        | 36 |
| 7.3 Feature Description.....                   | 15 | 11.6 Glossary.....   | 36 |
| 7.4 Device Functional Modes.....               | 21 | <b>12 Mechanical, Packaging, and Orderable Information</b> ..... | 37 |
| 7.5 Programming.....                           | 21 |  |    |

## 4 Revision History

NOTE: Page numbers for previous revisions may differ from page numbers in the current version.

| Changes from Revision B (October 2021) to Revision C (December 2021)   | Page |
|--|------|
| • Updated $V_{OUT}$ adjustment controlled slew rate percentage value.....                                      | 1    |
| • Added the pulse-width limitations on the enable pin.....   | 15   |
| • Added the resistance-tolerance value recommended to be placed on the $V_{SET}$ resistor divider network..... | 15   |
| • Added the maximum voltage ringing level value recommended.....   | 16   |
| • Added clarification on when Power Good is forced low.....  | 19   |
| • Added methods on how to prevent an over-current fault trigger at start-up.....                               | 19   |

| Changes from Revision A (October 2020) to Revision B (October 2021)   | Page |
|---|------|
| • Changed " $V_{VRSF}$ " to " $V_{RSP}$ " for $I_Q$ - PFM Mode current test condition in the <i>Electrical Characteristics</i> table.....             | 5    |
| • Changed $R_{FSEL}$ test condition values under <i>Switching Frequency</i> in the <i>Electrical Characteristics</i> .....                            | 5    |
| • Changed $R_{ILIM}$ test condition values under <i>Current Sense and Protection</i> in the <i>Electrical Characteristics</i> .....                   | 5    |
| • Changed title from "Line Regulation" to "Load Regulation" in <a href="#">Figure 6-8</a> and <a href="#">Figure 6-9</a> .....                        | 9    |
| • Removed "Chroma" from title of <a href="#">Figure 6-23</a> and <a href="#">Figure 6-24</a> .....  | 9    |
| • Updated $R_{FSEL}$ , $R_{COMP}$ , $R_{SS/PFM}$ and $R_{ILIM}$ with correct values across document.....  | 14   |
| • Changed $R_{FSEL}$ values in <a href="#">Table 7-1</a> .....  | 16   |
| • Changed $R_{COMP}$ values in <a href="#">Table 7-2</a> .....  | 16   |
| • Changed $R_{SS/PFM}$ values in <a href="#">Table 7-5</a> .....  | 18   |
| • Changed $R_{ILIM}$ values in <a href="#">Table 7-7</a> .....  | 19   |
| • Changed $R_{COMP}$ values in <a href="#">Table 7-8</a> .....  | 21   |
| • Updated the output voltage increments percentage value and removed the tables which included the binary codes for adjusting the output voltage..... | 22   |
| • Updated the RESERVED field to a R/W type.....   | 24   |
| • Updated all figures in <a href="#">Section 8.2.1.4</a> to demonstrate new $R_{FSEL}$ , $R_{COMP}$ , $R_{SS/PFM}$ and $R_{ILIM}$ values.....         | 31   |
| • Added information on Fusion Digital Power™ designer software tool.....  | 35   |

## 5 Pin Configuration and Functions

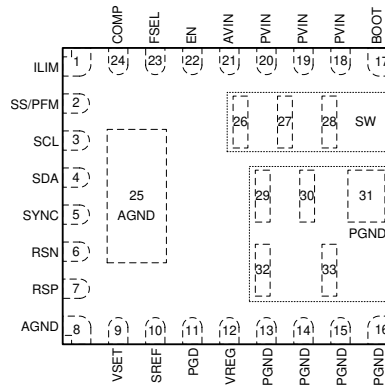

Figure 5-1. 33-Pin VQFN RJM Package (Top View)

Table 5-1. Pin Functions

| PIN    |              | I/O | DESCRIPTION  |
|--------|--------------|-----|--|
| NAME   | NO.          |     |  |
| AGND   | 8, 25        | G   | Ground of the internal analog and digital circuitry  |
| AVIN   | 21           | P   | Power input to the controller. Tie this pin to PVIN. It is best to use an RC filter from PVIN such as 10 $\Omega$ and 100 nF to 1 $\mu$ F.                                       |
| BOOT   | 17           | P   | Gate drive voltage for high-side FET. Connect a bootstrap capacitor between this pin and SW.   |
| COMP   | 24           | I   | A resistor to ground sets the I <sup>2</sup> C address and compensation network. This pin can be grounded to select the default compensation and reduce BOM count.               |
| EN     | 22           | I   | Enable pin. Float to enable, enable/disable with an external signal, or adjust the input undervoltage lockout with a resistor divider.   |
| FSEL   | 23           | I   | A resistor to ground sets the switching frequency of the converter. This pin can be grounded to select the default switching frequency to reduce BOM count.                      |
| ILIM   | 1            | I   | A resistor to ground sets the overcurrent protection limit. This pin can be grounded to select default settings and reduce BOM count.  |
| PGD    | 11           | O   | Open-drain power good status   |
| PGND   | 13-16, 29-33 | G   | Power ground. These pins are internally connected to the return of the internal low-side FET.  |
| PVIN   | 18-20        | P   | Power inputs to the power stage. Low impedance bypassing of these pins to PGND is critical. At least 10 nF to 100 nF capacitor from PVIN to PGND is required.                    |
| RSN    | 6            | I   | Remote sense ground return   |
| RSP    | 7            | I   | Remote sense connection to V <sub>OUT</sub>  |
| SCL    | 3            | I   | Clock input for I <sup>2</sup> C programming   |
| SDA    | 4            | I/O | Data input for I <sup>2</sup> C programming  |
| SREF   | 10           | O   | 1.2-V nominal system reference   |
| SS/PFM | 2            | I   | A resistor to ground sets the soft-start slew rate and PFM mode. To reduce BOM count this pin can be grounded to use the default soft-start rate and enable PFM mode.            |
| SYNC   | 5            | I   | In shutdown mode, an active high puts the IC into programming mode. In operation, this pin is a clock input for synchronizing the oscillator.                                    |
| SW     | 26-28        | O   | Switch node output of the converter. Connect this pin to the output inductor.  |
| VREG   | 12           | I/O | Bypass pin for the internal power stage LDO. It is recommended to use 4.7- $\mu$ F ceramic capacitor to ground.  |
| VSET   | 9            | I   | Output voltage reference for the control loop. This must be the mid-point of a resistive divider from SREF to AGND. Set this voltage to be 1/5 of the desired V <sub>OUT</sub> . |

## 6 Specifications

### 6.1 Absolute Maximum Ratings

over operating free-air temperature range (unless otherwise noted)<sup>(1)</sup>

|  |                                    | MIN  | MAX  | UNIT |
|--|------------------------------------|------|------|------|
| Input  | PVIN, AVIN                         | -0.3 | 20   | V    |
|  | PVIN - SW                          | -0.3 | 24   |      |
|  | BOOT                               | -0.3 | 27.5 |      |
|  | BOOT-SW                            | -0.3 | 5.5  |      |
|  | EN, SYNC, SDA, SCL                 | -0.3 | 6    |      |
|  | FS, COMP, ILIM, SS/PFM, SREF, VSET | -0.3 | 1.98 |      |
|  | RSP                                | -0.3 | 6    |      |
|  | PGD                                | -0.3 | 6    |      |
| Output   | SW                                 | -0.3 | 22   | V    |
|  | SW transient (<10 ns)              | -2   | 22   |      |
|  | VREG                               | -0.3 | 6    |      |
| Operating junction temperature, T <sub>J</sub> |                                    | -40  | 150  | °C   |
| Storage temperature, T <sub>stg</sub>          |                                    | -55  | 150  | °C   |

- (1) Stresses beyond those listed under *Absolute Maximum Rating* may cause permanent damage to the device. These are stress ratings only, which do not imply functional operation of the device at these or any other conditions beyond those indicated under *Recommended Operating Conditions*. Exposure to absolute-maximum-rated conditions for extended periods may affect device reliability.

### 6.2 ESD Ratings

|                    |                         |  | VALUE | UNIT |
|--------------------|-------------------------|--|-------|------|
| V <sub>(ESD)</sub> | Electrostatic discharge | Human body model (HBM), per ANSI/ESDA/ JEDEC JS-001, all pins <sup>(1)</sup>             | ±2500 | V    |
|                    |                         | Charged device model (CDM), per JEDEC specification JESD22-C101, all pins <sup>(2)</sup> | ±1000 |      |

- (1) JEDEC document JEP155 states that 500-V HBM allows safe manufacturing with a standard ESD control process.  
(2) JEDEC document JEP157 states that 250-V CDM allows safe manufacturing with a standard ESD control process.

### 6.3 Recommended Operating Conditions

T<sub>J</sub> = -40°C to 150°C (unless otherwise noted)

|  |                      | MIN | NOM | MAX | UNIT |
|--|----------------------|-----|-----|-----|------|
| PVIN, AVIN                             | Input voltage        | 4   | 12  | 18  | V    |
| VOUT                                   | Output voltage       | 0.5 |     | 5.5 | V    |
| IOUT                                   | Output current       | 0   |     | 15  | A    |
| EN, SDA, SCL                           |                      | 0   |     | 5.5 | V    |
| SYNC                                   |                      | 0   |     | 3.3 | V    |
| FS, COMP, ILIM, SS/<br>PFM, SREF, VSET |                      | 0   |     | 1.8 | V    |
| T <sub>J</sub>                         | Junction temperature | -40 |     | 150 | °C   |

## 6.4 Thermal Information

| THERMAL METRIC <sup>(1)</sup> |   | TPS542A50  | UNIT |
|-------------------------------|---|------------|------|
|                               |   | RJM (VQFN) |      |
|                               |   | 33 PINS    |      |
| R <sub>θJA</sub>              | Junction-to-ambient thermal resistance                | 54.9       | °C/W |
| R <sub>θJA</sub>              | Junction-to-ambient thermal resistance EVM PCB Layout | 22.3       | °C/W |
| R <sub>θJC(top)</sub>         | Junction-to-case (top) thermal resistance             | 23.3       | °C/W |
| R <sub>θJB</sub>              | Junction-to-board thermal resistance                  | 17.7       | °C/W |
| Ψ <sub>JT</sub>               | Junction-to-top characterization parameter            | 2.7        | °C/W |
| Ψ <sub>JB</sub>               | Junction-to-board characterization parameter          | 17.5       | °C/W |
| R <sub>θJC(bot)</sub>         | Junction-to-case (bottom) thermal resistance          | N/A        | °C/W |

(1) For more information about traditional and new thermal metrics, see the *Semiconductor and IC Package Thermal Metrics* application report, [SPRA953](#).

## 6.5 Electrical Characteristics

T<sub>J</sub> = -40°C to 150°C (unless otherwise noted)

| PARAMETER <sup>(1)</sup>                          |                                  | TEST CONDITIONS   | MIN  | TYP  | MAX  | UNIT |
|---|----------------------------------|---|------|------|------|------|
| <b>INPUT SUPPLY (PVIN, AVIN PINS)</b>             |                                  |   |      |      |      |      |
| V <sub>IN</sub>                                   | PVIN and AVIN supply range       |   | 4    | 12   | 18   | V    |
| I <sub>Q</sub>                                    | Shutdown current                 | EN < 0.4 V  |      | 17   |      | μA   |
|   | PFM Mode current                 | V <sub>IN</sub> = 12 V, V <sub>OUT</sub> = 1 V, EN > 1.2 V, no switching, V <sub>RSP</sub> > 5*V <sub>SET</sub> |      | 1800 |      |      |
| <b>ENABLE and UVLO (EN PIN)</b>                   |                                  |   |      |      |      |      |
| V <sub>EN</sub>                                   | Enable threshold: ON/OFF         | Rising and falling  |      | 1.2  |      | V    |
| I <sub>EN</sub>                                   | Enable input current             | Enable threshold – 50 mV  |      | –0.6 |      | μA   |
|   |                                  | Enable threshold + 50 mV  |      | –5   |      |      |
| <b>UVLO (AVIN, PVIN PINS)</b>                     |                                  |   |      |      |      |      |
| AVIN, PVIN  | UVLO rising threshold            |   | 3.75 | 3.85 | 4    | V    |
|   | UVLO falling threshold           |   | 3.50 | 3.6  | 3.7  |      |
|   | Hysteresis                       |   |      | 0.25 |      |      |
| <b>INTERNAL REGULATOR, POWER STAGE (VREG PIN)</b> |                                  |   |      |      |      |      |
| V <sub>VREG</sub>                                 | LDO output voltage               | LDO output current = 0A   | 4.3  | 4.7  | 4.96 | V    |
| V <sub>VREG</sub>                                 | LDO output voltage               | LDO output current = 30mA   |      | 4.7  |      | V    |
|   | Output current limit             | V <sub>VREG</sub> = 4.7V  | 120  | 170  | 220  | mA   |
|   | Nominal output current           | f <sub>sw</sub> = 2.2 MHz, output current = 15 A, V <sub>VREG</sub> = 4.7V                                      |      | 30   |      | mA   |
| V <sub>REG(UVLO)</sub>                            | UVLO rising threshold            |   |      | 2.8  |      | V    |
|   | UVLO falling threshold           |   |      | 2.6  |      |      |
|   | UVLO hysteresis                  |   |      | 0.2  |      |      |
| <b>CONTROL REFERENCE VOLTAGE (SREF PIN)</b>       |                                  |   |      |      |      |      |
| V <sub>SREF</sub>                                 | SREF output voltage              | Tolerance included in RSP/RSN accuracy  |      | 1.2  |      | V    |
| ISREF   | SREF current sourcing capability | Resistance > 6 kΩ   |      |      | 200  | μA   |

**TPS542A50**

SNVSB00C – SEPTEMBER 2020 – REVISED DECEMBER 2021

 $T_J = -40^{\circ}\text{C}$  to  $150^{\circ}\text{C}$  (unless otherwise noted)

| PARAMETER <sup>(1)</sup>                  |   | TEST CONDITIONS  | MIN   | TYP  | MAX  | UNIT |
|---|---|--|-------|------|------|------|
| <b>OUTPUT VOLTAGE REGULATION ACCURACY</b> |   |  |       |      |      |      |
|   | Output Voltage Accuracy; $V_{out} = 1\text{V}$                        | Total internal accuracy, measured at the RSP and RSN pins = $5 \times V_{SET}$ , $V_{SET} = 0.2\text{V}$ , $-40$ to $150^{\circ}\text{C}$  | -15   |      | 15   | mV   |
|   | Output Voltage Accuracy; $V_{out} = 1\text{V}$                        | Total internal accuracy, measured at the RSP and RSN pins = $5 \times V_{SET}$ , $V_{SET} = 0.2\text{V}$ , $-40$ to $125^{\circ}\text{C}$  | -13   |      | 13   | mV   |
|   | Output Voltage Accuracy; $V_{out} = 1\text{V}$                        | Total internal accuracy, measured at the RSP and RSN pins = $5 \times V_{SET}$ , $V_{SET} = 0.2\text{V}$ , $0$ to $105^{\circ}\text{C}$    | -11.0 |      | 9.0  | mV   |
|   | Output Voltage Accuracy; $V_{out} = 0.8\text{V}$                      | Total internal accuracy, measured at the RSP and RSN pins = $5 \times V_{SET}$ , $V_{SET} = 0.16\text{V}$ , $-40$ to $150^{\circ}\text{C}$ | -15   |      | 15   | mV   |
|   | Output Voltage Accuracy; $V_{out} = 1.2\text{V}$                      | Total internal accuracy, measured at the RSP and RSN pins = $5 \times V_{SET}$ , $V_{SET} = 0.24\text{V}$ , $-40$ to $150^{\circ}\text{C}$ | -15   |      | 15   | mV   |
|   | Output Voltage Accuracy; $V_{out} = 5.5\text{V}$ <sup>(1)</sup>       | Total internal accuracy, measured at the RSP and RSN pins = $5 \times V_{SET}$ , $V_{SET} = 1.1\text{V}$ , $-40$ to $150^{\circ}\text{C}$  | -30   |      | 30   | mV   |
| <b>REMOTE SENSE AMPLIFIER</b>             |   |  |       |      |      |      |
|   | Unity gain bandwidth <sup>(1)</sup>                                   |  |       | 7    |      | MHz  |
|   | Open loop gain <sup>(1)</sup>   |  |       | 83   |      | dB   |
|   | Slew rate <sup>(1)</sup>  |  |       | 2.5  |      | V/us |
|   | Input common mode range <sup>(1)</sup>                                |  | -0.05 |      | 1.1  | V    |
| $V_{os}$                                  | Input offset voltage (RSA and EA combined offset trim) <sup>(1)</sup> |  |       | 0.25 |      | mV   |
| <b>SWITCHING FREQUENCY</b>                |   |  |       |      |      |      |
| FSW_1MHz                                  | Switching frequency 1MHz  | $R_{FSEL} = 35.7\text{ k}\Omega$ or Short  | 900   | 1000 | 1100 | kHz  |
| FSW_400kHz                                | Switching frequency 400kHz  | $R_{FSEL} = 7.5\text{ k}\Omega$  | -10   |      | +15  | %    |
| FSW_600kHz                                | Switching frequency 600kHz  | $R_{FSEL} = 18.2\text{ k}\Omega$   | -10   |      | +15  | %    |
| FSW_800kHz                                | Switching frequency 800kHz  | $R_{FSEL} = 26.1\text{ k}\Omega$   | -10   |      | +15  | %    |
| FSW_1.2MHz                                | Switching frequency 1.2MHz  | $R_{FSEL} = 47.5\text{ k}\Omega$   | -9    |      | +11  | %    |
| FSW_2MHz                                  | Switching frequency 2MHz  | $R_{FSEL} = 61.9\text{ k}\Omega$   | -10   |      | +15  | %    |
| FSW_2.2MHz                                | Switching frequency 2.2MHz  | $R_{FSEL} = 78.7\text{ k}\Omega$   | -10   |      | +15  | %    |
|   | Minimum On-Time   |  |       | 12   |      | ns   |
|   | Minimum Off-Time  |  |       | 85   |      | ns   |
| <b>SYNC</b>                               |   |  |       |      |      |      |
| $V_{IH(SYNC)}$                            | High-level input voltage  | EN = High  | 1.35  |      |      | V    |
| $V_{IL(SYNC)}$                            | Low-level input voltage   |  |       |      | 0.8  | V    |
|   | Sync input minimum pulse width  |  |       |      | 50   | ns   |
| $\Delta f_{SYNC}$                         | SYNC pin frequency range from $f_{SW}$                                |  | -10%  |      | 15%  |      |
| $V_{IH(SYNC)-PROG}$                       | High-level input voltage to enter programming mode when EN = 0V       | EN = Low   | 1.35  |      |      | V    |
| <b>I2C COMMUNICATION (SDA, SCL)</b>       |   |  |       |      |      |      |
| $V_{IH(I2C)}$                             | High-level input voltage  |  | 1.35  |      |      | V    |
| $V_{IL(I2C)}$                             | Low-level input voltage   |  |       |      | 0.8  | V    |

$T_J = -40^{\circ}\text{C}$  to  $150^{\circ}\text{C}$  (unless otherwise noted)

| PARAMETER <sup>(1)</sup>                   |  | TEST CONDITIONS   | MIN   | TYP  | MAX   | UNIT                  |
|--|--|---|-------|------|-------|-----------------------|
| $I_{IH(I2C)}$                              | High-level input leakage current                           |   | -5    |      | 5     | $\mu\text{A}$         |
| $I_{IL(I2C)}$                              | Low-level input leakage current                            |   | -5    |      | 5     | $\mu\text{A}$         |
| $V_{OL(I2C)}$                              | Low-level output voltage                                   | $I_{PULLUP} = 20\text{mA}$  |       |      | 0.4   | V                     |
| $I_{PULLUP}$                               | Current through pull-up resistor                           |   |       |      | 20    | mA                    |
| $f_{CLK(I2C)}$                             | I2C operating frequency                                    |   | 10    |      | 1000  | kHz                   |
| $C_{Pin}$                                  | Typical pin capacitance for each line (SDA, SCL)           |   |       | 10   |       | pF                    |
| <b>POWER STAGE</b>                         |  |   |       |      |       |                       |
| $R_{ds(on)1}$                              | Main high-side MOSFET on-resistance                        | $V_{VREG} = 4.7\text{V}$ , $T_J = 25^{\circ}\text{C}$               |       | 9.1  |       | $\text{m}\Omega$      |
| $R_{ds(on)2}$                              | Main Low-side MOSFET on-resistance                         | $V_{VREG} = 4.7\text{V}$ , $T_J = 25^{\circ}\text{C}$               |       | 2.6  |       | $\text{m}\Omega$      |
| $Tdt(L-H)$                                 | Dead-time between low-side off and high-side on transition | $V_{VREG} = 4.7\text{V}$ , $T_J = 25^{\circ}\text{C}$               |       | 10   |       | ns                    |
| $Tdt(H-L)$                                 | Dead-time between high-side off and low-side on transition | $V_{VREG} = 4.7\text{V}$ , $T_J = 25^{\circ}\text{C}$               |       | 10   |       | ns                    |
| <b>CURRENT SENSE AND PROTECTION</b>        |  |   |       |      |       |                       |
| IS1  | OC limit HS FET  |   |       | 20   |       | A                     |
| IS2  | OC limit LS FET 6  | $R_{ILIM} = 61.9\text{ k}\Omega$                                    | 17.60 | 20   | 22    | A                     |
|  | OC limit LS FET 5  | $R_{ILIM} = 47.5\text{ k}\Omega$                                    | 14.78 | 16.5 | 18.48 |                       |
|  | OC limit LS FET 4  | $R_{ILIM} = 35.7\text{ k}\Omega$                                    | 11.56 | 13   | 15.62 |                       |
|  | OC limit LS FET 3  | $R_{ILIM} = 26.1\text{ k}\Omega$                                    | 9.26  | 10.5 | 13.56 |                       |
|  | OC limit LS FET 2  | $R_{ILIM} = 18.2\text{ k}\Omega$                                    | 6.96  | 8    | 11.60 |                       |
|  | OC limit LS FET 1  | $R_{ILIM} = 7.5\text{ k}\Omega$                                     | 4.66  | 5.5  | 9.60  |                       |
| IS2  | Negative OC limit LS FET                                   |   |       | -8.5 |       | A                     |
| IS2  | Zero-cross detection comparator trip point                 |   |       | 135  |       | mA                    |
| <b>SOFT-START COUNTER</b>                  |  |   |       |      |       |                       |
| $t_{SS}$                                   | SS setting 1: 2.0MHz CLK                                   | $V_{VSET} = 0.1\text{V}$ to $0.28\text{V}$                          |       | 0.45 |       | ms                    |
|  | SS setting 2: 1.0MHz CLK                                   | $V_{VSET} = 0.1\text{V}$ to $0.28\text{V}$                          |       | 0.9  |       |                       |
|  | SS setting 3: 0.5MHz CLK                                   | $V_{VSET} = 0.1\text{V}$ to $0.28\text{V}$                          |       | 1.8  |       |                       |
|  | SS setting 4: 0.25MHz CLK                                  | $V_{VSET} = 0.1\text{V}$ to $0.28\text{V}$                          |       | 3.6  |       |                       |
| <b>OUTPUT ADJUSTMENT</b>                   |  |   |       |      |       |                       |
|  | Output voltage adjust upper limit                          |   |       | 10   |       | %                     |
|  | Output voltage adjust lower limit                          |   |       | -20  |       | %                     |
|  | Step size  |   |       |      | 0.5   | %                     |
| <b>INTERNAL BOOTSTRAP SWITCH</b>           |  |   |       |      |       |                       |
|  | Forward voltage  | $V_{VREG(BOOT)}$ , $I_F = 10\text{mA}$ , $T_A = 25^{\circ}\text{C}$ |       | 0.16 | 0.3   | V                     |
| <b>OUTPUT VOLTAGE OVERTHOOT REDUCTION</b>  |  |   |       |      |       |                       |
| <b>POWER-ON DELAY</b>                      |  |   |       |      |       |                       |
|  | Power-on delay time  | From EN to SS; $V_{IN} > 4\text{V}$                                 |       | 500  |       | us                    |
| <b>POWER GOOD and OV/UV WARNING</b>        |  |   |       |      |       |                       |
| $V_{RSP}$                                  | OV warning level   | RSP rising (fault)  | 105   | 110  | 115   | % $5^{\circ}V_{VSET}$ |
|  | OV warning level   | RSP falling (reset)   | 100   | 105  | 109   |                       |
|  | UV warning level   | RSP falling (fault)   | 87    | 90   | 93.5  |                       |
|  | UV warning level   | RSP rising (reset)  | 91    | 95   | 99    |                       |
|  | PGD delay time   | Delay from SS finish to PGD high                                    |       | 500  |       | $\mu\text{s}$         |
| $R_{ds(on)PGFET}$                          |  | PGD FET On Resistance, $I_{PGOOD} = 5\text{mA}$                     | 4.1   | 5.8  | 9.1   | $\Omega$              |
| <b>OUTPUT OVERVOLTAGE PROTECTION (OVP)</b> |  |   |       |      |       |                       |

**TPS542A50**

SNVSB00C – SEPTEMBER 2020 – REVISED DECEMBER 2021

 $T_J = -40^{\circ}\text{C}$  to  $150^{\circ}\text{C}$  (unless otherwise noted)

| PARAMETER <sup>(1)</sup>                    |                                     | TEST CONDITIONS                                | MIN | TYP | MAX | UNIT                     |
|---|-------------------------------------|--|-----|-----|-----|--------------------------|
| V <sub>RSP</sub>                            | OVP trip level                      | RSP rising (fault), V <sub>VSET</sub> ≤ 1.04 V | 110 | 115 | 120 | %                        |
|   | OVP reset level                     | RSP falling                                    | 76  | 80  | 84  | 5*V <sub>VSET</sub>      |
|   | OVP delay                           |  |     | 100 |     | ns                       |
| <b>OUTPUT UNDERVOLTAGE PROTECTION (UVP)</b> |                                     |  |     |     |     |                          |
| V <sub>RSP</sub>                            | UVP detect voltage                  |  | 76  | 80  | 84  | %<br>5*V <sub>VSET</sub> |
|   | UV delay                            |  |     | 100 |     | ns                       |
| <b>THERMAL SHUTDOWN</b>                     |                                     |  |     |     |     |                          |
| T <sub>SDN</sub>                            | Shutdown temperature <sup>(1)</sup> |  | 155 | 165 |     | °C                       |
|   | Hysteresis <sup>(1)</sup>           |  |     | 15  |     | °C                       |

(1) Specified by design. Not production tested.



## 6.6 Typical Characteristics

Measured at 25°C unless otherwise specified

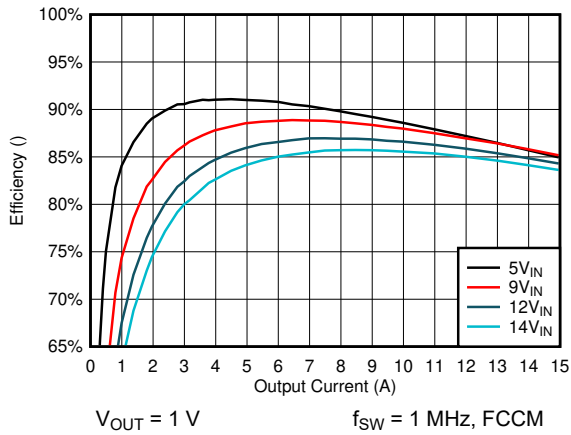

**Figure 6-1. Efficiency vs Output Current**

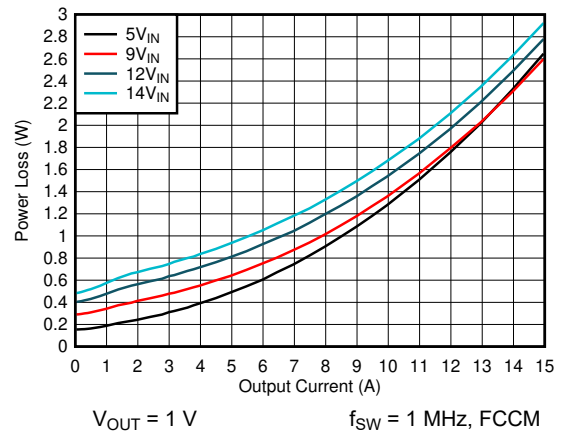

**Figure 6-2. Power Loss vs Output Current**

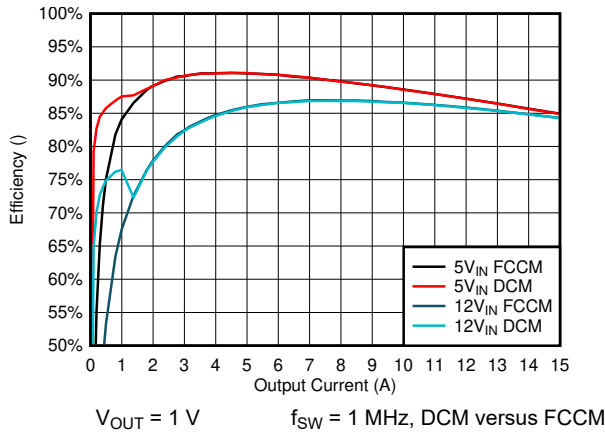

**Figure 6-3. Efficiency vs Output Current**

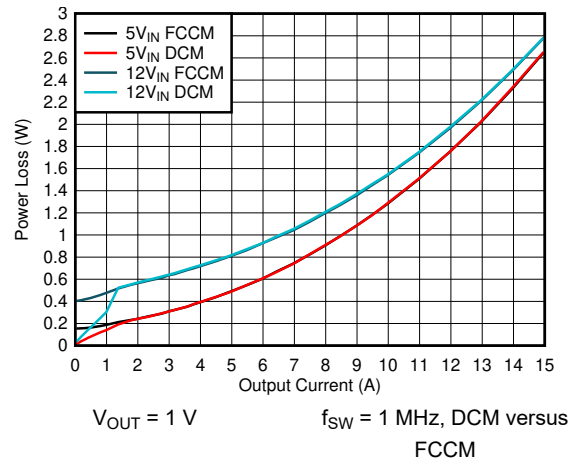

**Figure 6-4. Power Loss vs Output Current**

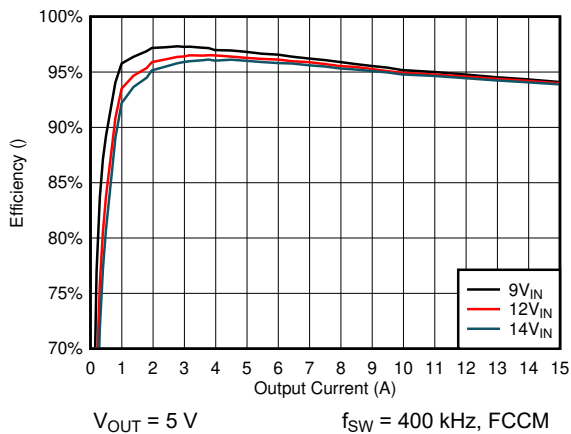

**Figure 6-5. Efficiency vs Output Current**

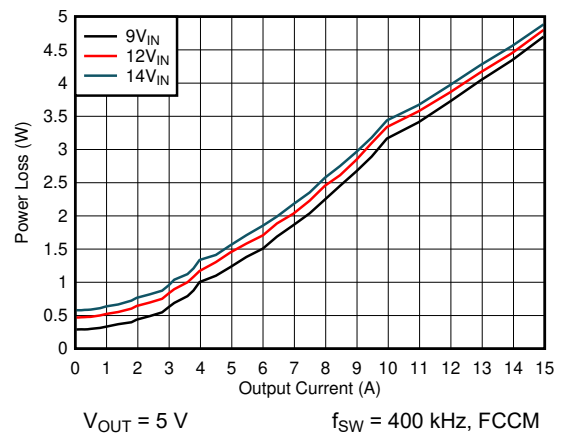

**Figure 6-6. Power Loss vs Output Current**

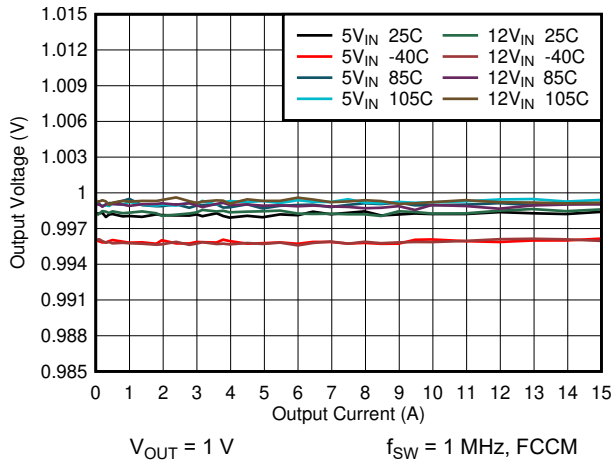

**Figure 6-7. Load Regulation**

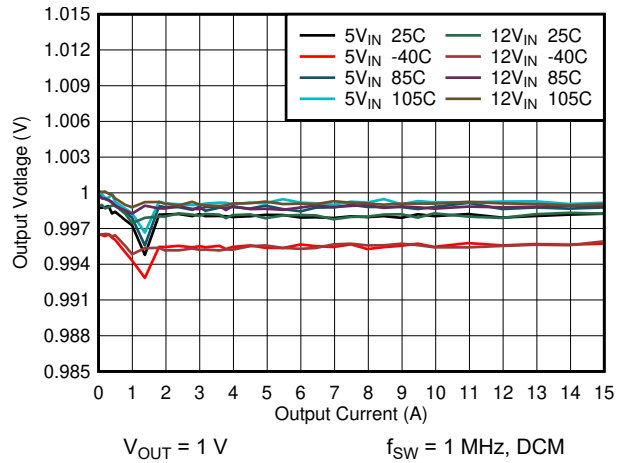

**Figure 6-8. Load Regulation**

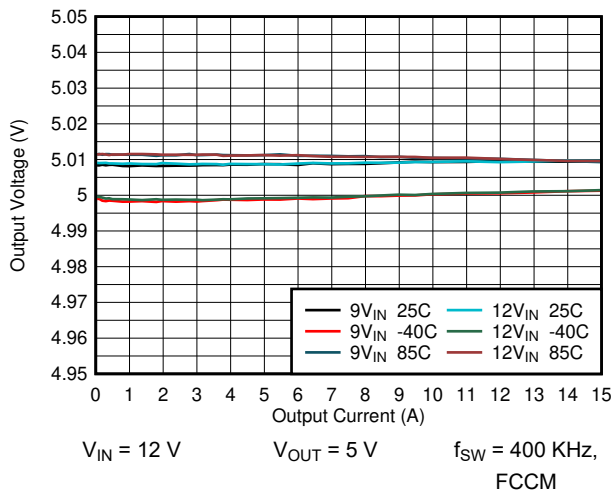

**Figure 6-9. Load Regulation**

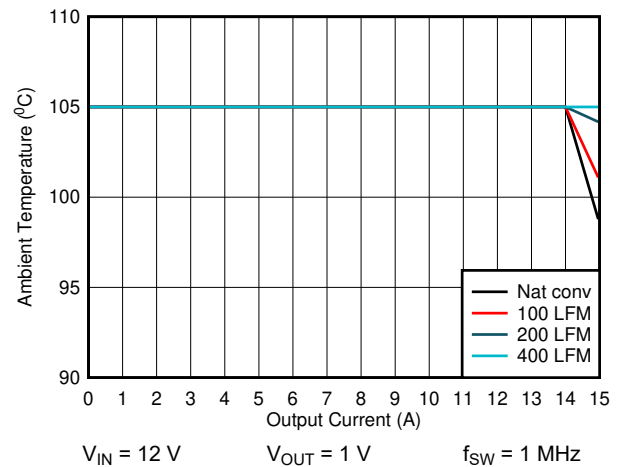

**Figure 6-10. Ambient Temperature vs Output Current**

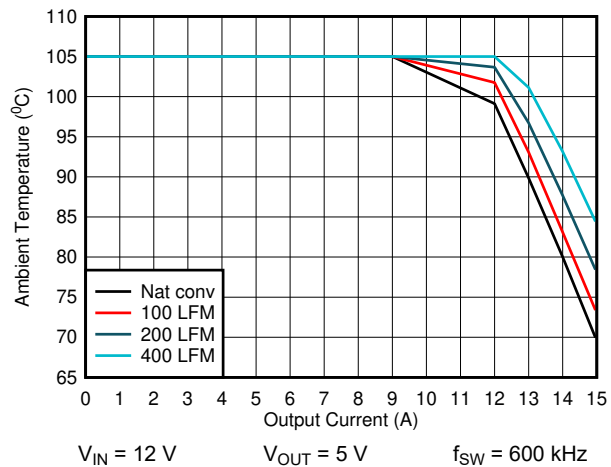

**Figure 6-11. Ambient Temperature vs Output Current**

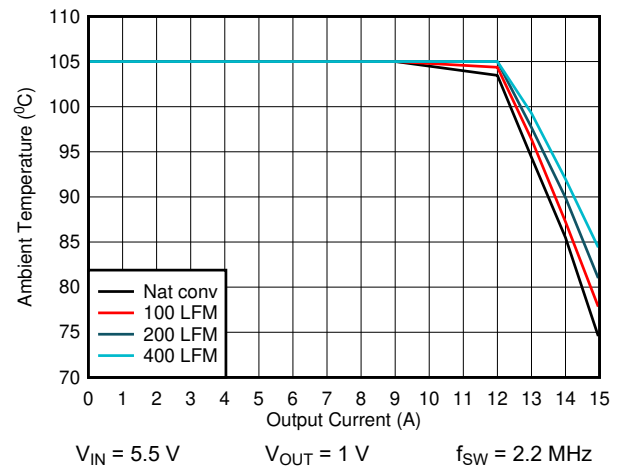

**Figure 6-12. Ambient Temperature vs Output Current**



$V_{IN} = 12\text{ V}$      $V_{OUT} = 1\text{ V}$      $f_{SW} = 1\text{ MHz}$

Figure 6-13. Thermal Image at 15-A Output Current



$V_{IN} = 5.5\text{ V}$      $V_{OUT} = 1\text{ V}$      $f_{SW} = 2.2\text{ MHz}$

Figure 6-14. Thermal Image at 14-A Output Current

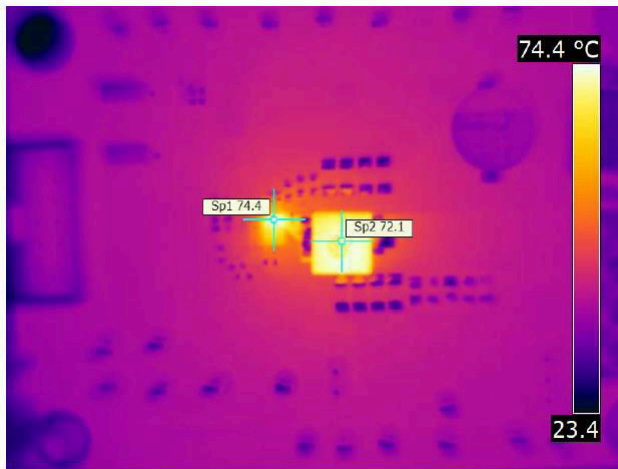

$V_{IN} = 12\text{ V}$      $V_{OUT} = 5\text{ V}$      $f_{SW} = 0.6\text{ MHz}$

Figure 6-15. Thermal Image at 12-A Output Current

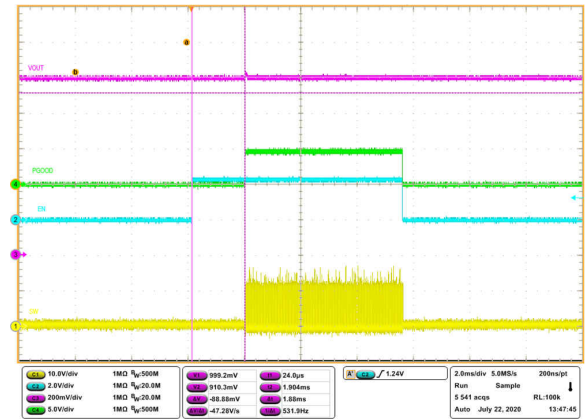

$V_{IN} = 12\text{ V}$      $V_{OUT} = 1\text{ V}$      $f_{SW} = 1.0\text{ MHz BOM}$

Figure 6-16. 100% Pre-biased Start-up by EN at 0-A Output Current

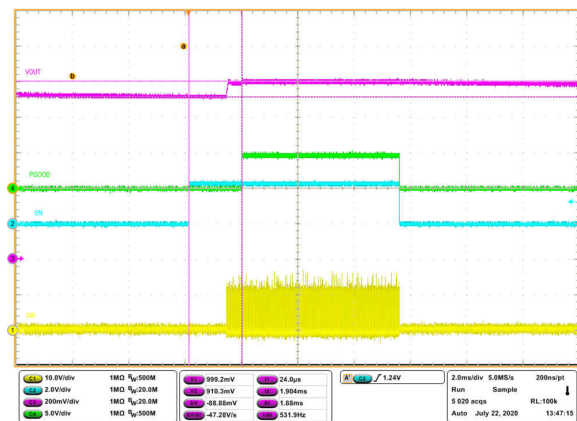

$V_{IN} = 12\text{ V}$      $V_{OUT} = 1\text{ V}$      $f_{SW} = 1.0\text{ MHz BOM}$

Figure 6-17. 90% Pre-biased Start-up by EN at 0-A Output Current

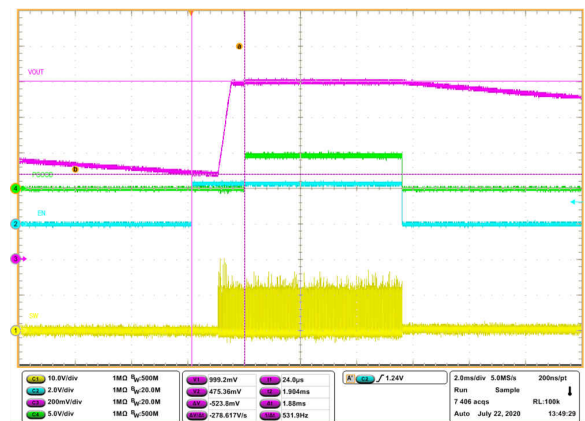

$V_{IN} = 12\text{ V}$      $V_{OUT} = 1\text{ V}$      $f_{SW} = 1.0\text{ MHz BOM}$

Figure 6-18. 50% Pre-biased Start-up by EN at 0-A Output Current

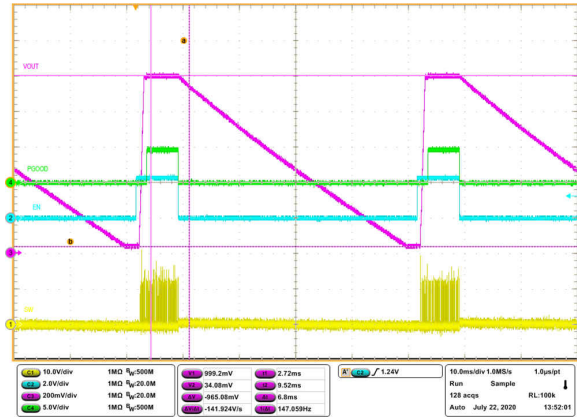

$V_{IN} = 12\text{ V}$        $V_{OUT} = 1\text{ V}$        $f_{SW} = 1.0\text{ MHz BOM}$

**Figure 6-19. Start-up and Shutdown by EN at 0-A Output Current**

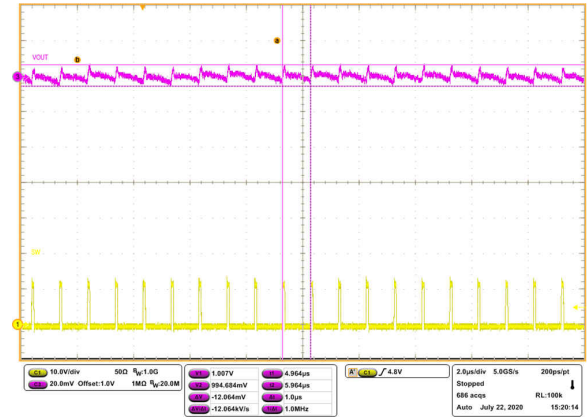

$V_{IN} = 12\text{ V}$        $V_{OUT} = 1\text{ V}$        $f_{SW} = 1.0\text{ MHz BOM}$

**Figure 6-20. Steady State at 0-A Output Current**

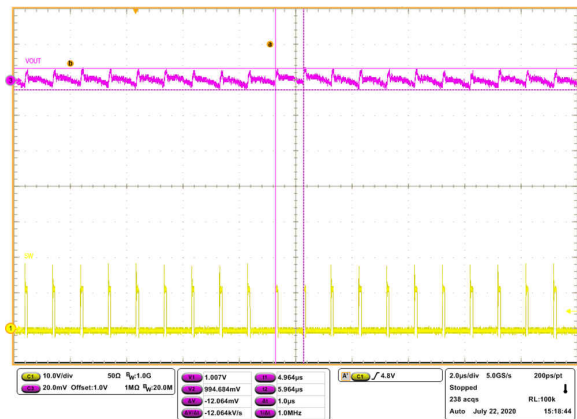

$V_{IN} = 12\text{ V}$        $V_{OUT} = 1\text{ V}$        $f_{SW} = 1.0\text{ MHz BOM}$

**Figure 6-21. Steady State at 10-A Output Current**



$V_{IN} = 12\text{ V}$        $V_{OUT} = 1\text{ V}$        $f_{SW} = 1.0\text{ MHz BOM}$

**Figure 6-22. Switch Node Ringing and Dead-Time at 10-A Output Current**

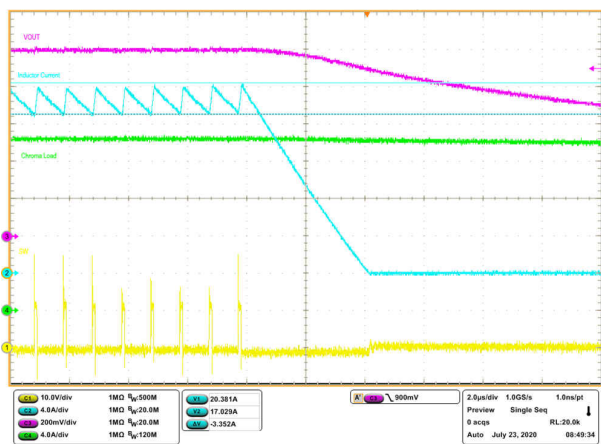

$V_{IN} = 12\text{ V}$        $V_{OUT} = 1\text{ V}$        $f_{SW} = 1.0\text{ MHz BOM}$

**Figure 6-23. 20-A Overcurrent Protection by Electronic Load**

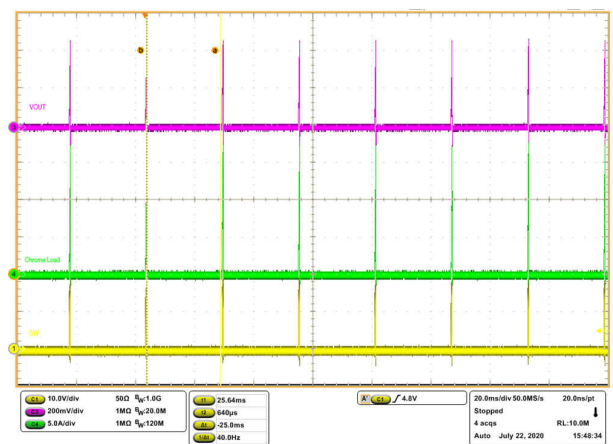

$V_{IN} = 12\text{ V}$        $V_{OUT} = 1\text{ V}$        $f_{SW} = 1.0\text{ MHz BOM}$

**Figure 6-24. Short Overcurrent Protection Hiccup by Electronic Load**

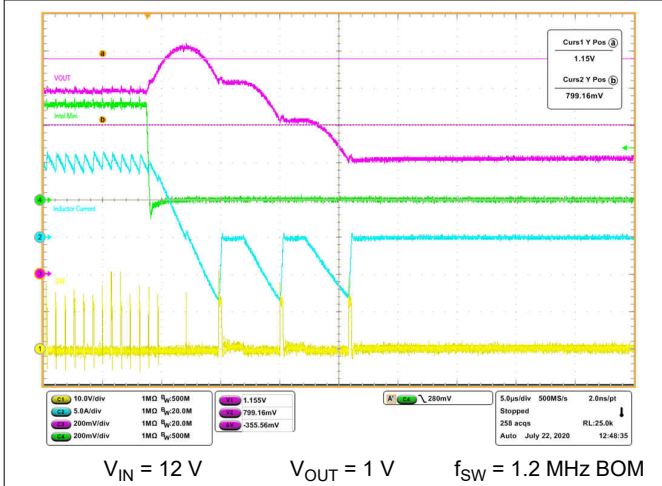

**Figure 6-25. Overvoltage Protection, Negative OCP, then Undervoltage Protection by Load Stepdown**

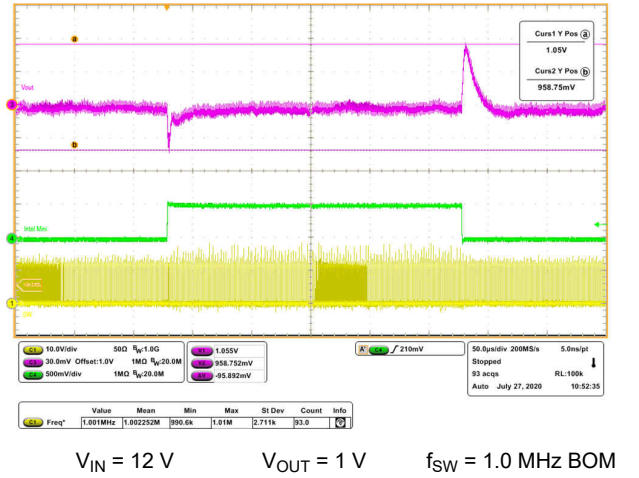

**Figure 6-26. Load Transient 2 A to 12 A to 2 A at 20 A/μs**

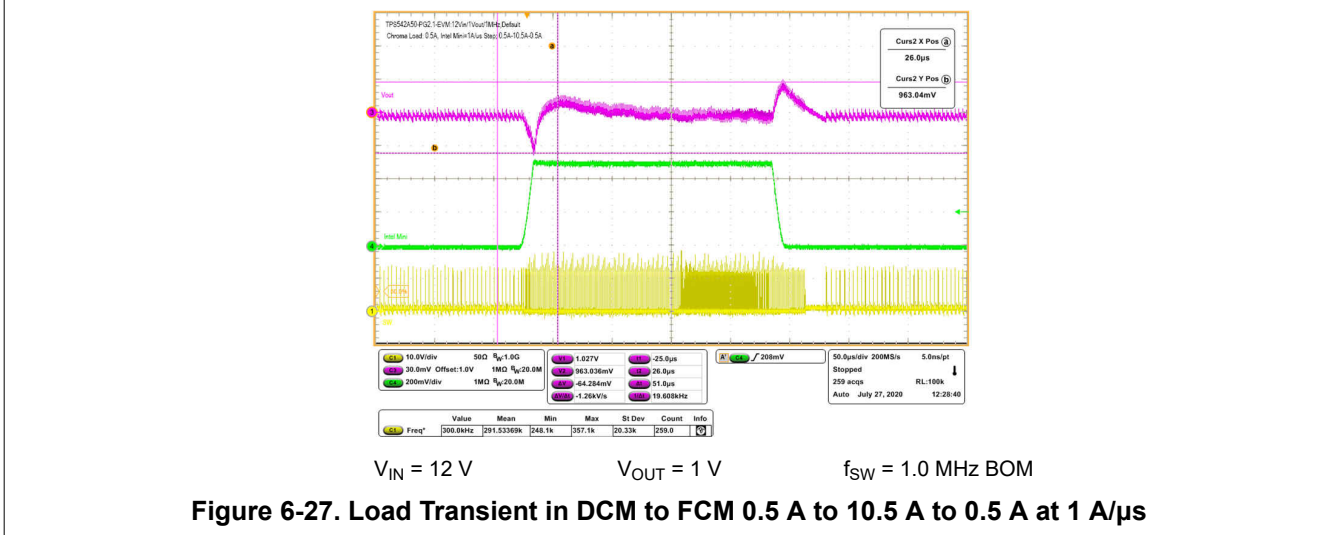

**Figure 6-27. Load Transient in DCM to FCM 0.5 A to 10.5 A to 0.5 A at 1 A/μs**



## 7 Detailed Description

### 7.1 Overview

The TPS542A50 is a high-efficiency, single-channel, synchronous buck converter with integrated n-channel MOSFETs. The device suits low-output voltage point-of-load applications with 15-A or lower current. The TPS542A50 has a maximum operating junction temperature of 150°C, making it suitable for high-ambient temperature applications such as wireless infrastructure. The input voltage range is 4 V to 18 V, and the output voltage range is 0.5 V to 5.5 V. The device features a fixed-frequency, voltage-control mode with a switching frequency range of 400 kHz to 2.2 MHz, allowing for efficiency and size optimization when selecting output filter components. The controller features selectable internal compensation that makes the device easy to use with low external component count. The internal compensation networks support a wide range of output inductance and capacitance, supporting all types of capacitors. The controller uses a digital PWM modulator that allows for very narrow on-times with low jitter, making it ideal for high-frequency and high-step down ratio applications. The switching frequency of the device can be synchronized to an external clock applied to the SYNC pin. The TPS542A50 also features an I<sup>2</sup>C interface for device configuration and output voltage adjustment.

### 7.2 Functional Block Diagram

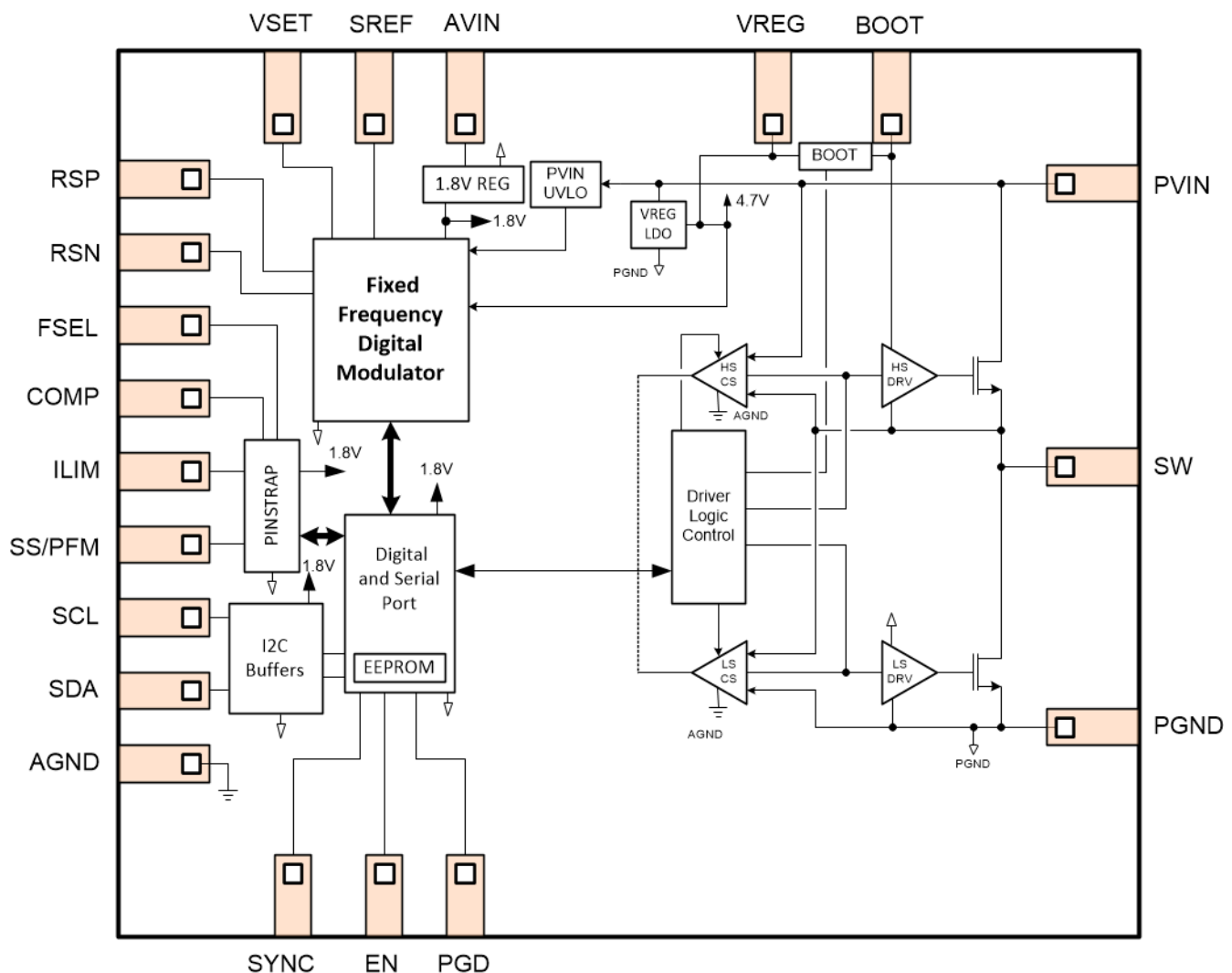

## 7.3 Feature Description

### 7.3.1 Enable and Adjustable Undervoltage Lockout

The EN pin provides electrical on/off control of the device. Once the EN pin voltage exceeds the threshold voltage (typically 1.2 V), the device starts operation. If the EN pin voltage is pulled below the threshold voltage, the regulator stops switching and enters low power shutdown.

The EN pin has an internal pullup current source, allowing the user to float the EN pin for enabling the device. The EN pin can also be externally driven high or low. When the pulse-width is less than 22us, the EN pin will detect the pulse as a low and cause the device to enter hiccup-mode. If the pulse-width is greater than 22us, then the EN pin will detect the pulse as low but will not enter hiccup-mode.

For adjustable input undervoltage lockout (UVLO), connect the EN pin to the middle point of an external resistor divider. Once the EN pin voltage exceeds the threshold, an additional 5 μA of hysteresis current is added to facilitate UVLO hysteresis. Equation 1 shows the calculation of resistor divider network.

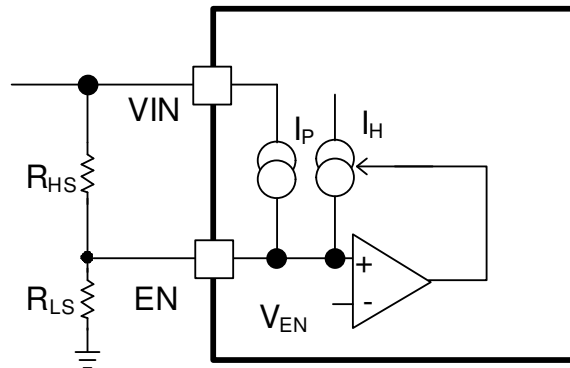

Figure 7-1. EN UVLO

$$R_{HS} = \frac{V_{START} - V_{STOP}}{I_H}$$

$$R_{LS} = \frac{R_{HS} \cdot V_{EN}}{V_{STOP} - V_{EN} + R_{HS}(I_P + I_H)}$$

$$V_{EN} = 1.2V; I_P = 0.6\mu A; I_H = 5\mu A \quad (1)$$

### 7.3.2 Input and VREG Undervoltage Lockout Protection

The TPS542A50 provides fixed VIN and VREG UVLO thresholds and hysteresis. The typical VIN turnon threshold is 3.85 V and hysteresis is 0.25 V. The typical VREG turnon threshold is 2.8 and hysteresis is 0.2 V. There is no power-up sequence. Once all of the UVLO requirements have been met and the EN pin voltage exceeds the enable threshold, the converter begins operation.

### 7.3.3 Voltage Reference and Setting the Output Voltage

The device has a 1.2-V reference that comes out on the SREF pin. To set the reference voltage of the converter, connect the VSET pin to the mid-point of a resistor divider between SREF and AGND. TI recommends that the total impedance of this divider network be > 6 kΩ. For best accuracy, the resistor's tolerance of 0.1% is recommended. Do not connect anything other than a resistor divider network to SREF.

There is an internal 5:1 resistor divider between the RSP and RSN feedback pins, so the VSET voltage must be set to 1/5 of the desired output voltage. VSET can be programmed to any value between 0.1 and 1.1 V.

### 7.3.4 Remote Sense Function

RSP and RSN pins are used for remote sensing purposes. Always connect RSP to the positive sensing point of the load, and always connect the RSN pin to the load return. There is an internal 5:1 divider in the device, so do

not connect an external feedback resistor divider. The converter loop gain can tolerate between 10  $\Omega$  to 50  $\Omega$  in series with RSP and output voltage.

### 7.3.5 Switching Frequency

The internal oscillator of the device can be set to one of seven switching frequencies by a resistor to ground on the FSEL pin or through I<sup>2</sup>C programming. The FSEL pin can be shorted to ground to reduce BOM component count. When shorted to ground, the default converter switching frequency is used. If the user programs the switching frequency using the I<sup>2</sup>C interface, TI recommends shorting the FSEL pin to ground to reduce component count. The following frequencies can be programmed on the FSEL pin.

**Table 7-1. Frequency Resistor Selection**

| R <sub>FSEL</sub> (k $\Omega$ ) | f <sub>sw</sub> (kHz) |
|---------------------------------|-----------------------|
| Short                           | 1000                  |
| 7.5                             | 400                   |
| 18.2                            | 600                   |
| 26.1                            | 800                   |
| 35.7                            | 1000                  |
| 47.5                            | 1200                  |
| 61.9                            | 2000                  |
| 78.7                            | 2200                  |

The oscillator can also be synchronized to an external clock on the SYNC pin. The external clock frequency must be within -10% and +15% of the programmed frequency of the converter. The SYNC pin has an internal pulldown so it can be left floating externally.

When the converter operates at 2 MHz or 2.2 MHz, it is recommended to set the OCP at 13 A or lower and without a snubber circuit. For operation with OCP at 16.5 A, a snubber circuit is required. The snubber circuit components can start with a 470-pF cap and 2- $\Omega$  resistor to help reduce voltage ringing levels. It is recommended for the ringing levels to be 2-V below the Absolute Maximum Ratings between SW and GND at room temperature. The component values will need to be tuned to achieve optimal results.

### 7.3.6 Voltage Control Mode Internal Compensation

The TPS542A50 has 15 unique internal compensation settings to cover a wide range of output inductors and capacitors. For each switching frequency option, there are four compensation options that can be chosen using a single resistor to ground on the COMP pin or through I<sup>2</sup>C programming.

In addition to selecting the compensation option, the COMP pin also selects the device I<sup>2</sup>C address. The following compensation settings and I<sup>2</sup>C address combinations can be programmed on the COMP pin.

**Table 7-2. Compensation and I<sup>2</sup>C Address Resistor Selection**

| R <sub>COMP</sub> (k $\Omega$ ) | I <sup>2</sup> C ADDRESS | COMPENSATION SETTING |
|---------------------------------|--------------------------|----------------------|
| Short                           | 0x60                     | COMP 2               |
| 7.5                             | 0x60                     | COMP 1               |
| 18.2                            |                          | COMP 2               |
| 26.1                            |                          | COMP 3               |
| 35.7                            |                          | COMP 4               |
| 47.5                            |                          | COMP 1               |
| 61.9                            | 0x61                     | COMP 2               |
| 78.7                            |                          | COMP 3               |
| 102                             |                          | COMP 4               |



Each compensation network consists of two zeros and one high frequency pole. [Table 7-3](#) maps the compensation settings to the first zero frequency at different output voltage range, second zero frequency, and high frequency pole.

**Table 7-3. Compensation Settings**

| FREQUENCY (kHz) | COMPENSATION SETTING | ZERO 1 (kHz) FOR VOUT = 0.5 V-1.1 V | ZERO 1 (kHz) for VOUT = 1.2 V-1.5 V | ZERO 1 (kHz) FOR VOUT = 1.6 V-2.8 V | ZERO 1 (kHz) FOR VOUT = 2.9 V-4.0 V | ZERO 1 (kHz) for VOUT = 4.1 V-5.5 V | ZERO 2 (kHz) | POLE (kHz) |
|-----------------|----------------------|-------------------------------------|-------------------------------------|-------------------------------------|-------------------------------------|-------------------------------------|--------------|------------|
| 400             | COMP 1               | 2.2                                 | 2.1                                 | 1.8                                 | 1.6                                 | 1.2                                 | 5.5          | 60         |
|                 | COMP 2               | 2.2                                 | 2.1                                 | 1.8                                 | 1.6                                 | 1.2                                 | 7.3          | 80         |
|                 | COMP 3               | 3.6                                 | 3.4                                 | 3.0                                 | 2.7                                 | 2.0                                 | 14.5         | 159        |
|                 | COMP 4               | 7.2                                 | 7.0                                 | 6.1                                 | 5.4                                 | 4.1                                 | 28.4         | 312        |
| 600             | COMP 1               | 2.2                                 | 2.1                                 | 1.8                                 | 1.6                                 | 1.2                                 | 5.5          | 60         |
|                 | COMP 2               | 2.7                                 | 2.6                                 | 2.3                                 | 2.0                                 | 1.5                                 | 11.0         | 121        |
|                 | COMP 3               | 4.5                                 | 4.3                                 | 3.8                                 | 3.4                                 | 2.5                                 | 18.1         | 199        |
|                 | COMP 4               | 10.5                                | 10.1                                | 8.8                                 | 7.9                                 | 5.9                                 | 45.2         | 497        |
| 800             | COMP 1               | 2.2                                 | 2.1                                 | 1.8                                 | 1.6                                 | 1.2                                 | 7.3          | 80         |
|                 | COMP 2               | 3.6                                 | 3.4                                 | 3.0                                 | 2.7                                 | 2.0                                 | 14.5         | 159        |
|                 | COMP 3               | 7.2                                 | 7.0                                 | 6.0                                 | 5.4                                 | 4.1                                 | 28.4         | 312        |
|                 | COMP 4               | 13.5                                | 13                                  | 11.4                                | 10.1                                | 7.6                                 | 55.6         | 612        |
| 1000            | COMP 1               | 2.2                                 | 2.1                                 | 1.9                                 | 1.7                                 | 1.2                                 | 9.0          | 99         |
|                 | COMP 2               | 4.5                                 | 4.3                                 | 3.8                                 | 3.4                                 | 2.5                                 | 18.1         | 199        |
|                 | COMP 3               | 9.0                                 | 8.7                                 | 7.6                                 | 6.7                                 | 5.1                                 | 37.1         | 408        |
|                 | COMP 4               | 18.8                                | 18.2                                | 15.9                                | 14.1                                | 10.6                                | 72.3         | 796        |
| 1200            | COMP 1               | 2.7                                 | 2.6                                 | 2.3                                 | 2.0                                 | 1.5                                 | 11.0         | 121        |
|                 | COMP 2               | 4.5                                 | 4.3                                 | 3.8                                 | 3.4                                 | 2.5                                 | 18.1         | 199        |
|                 | COMP 3               | 10.5                                | 10.1                                | 8.8                                 | 7.9                                 | 5.9                                 | 45.2         | 497        |
|                 | COMP 4               | 23.5                                | 22.7                                | 19.9                                | 17.7                                | 13.3                                | 90.4         | 995        |
| 2000            | COMP 1               | 4.5                                 | 4.3                                 | 3.8                                 | 3.4                                 | 2.5                                 | 18.1         | 199        |
|                 | COMP 2               | 9                                   | 8.7                                 | 7.6                                 | 6.7                                 | 5.1                                 | 37.1         | 408        |
|                 | COMP 3               | 18.8                                | 18.2                                | 15.9                                | 14.1                                | 10.6                                | 72.3         | 796        |
|                 | COMP 4               | 37.7                                | 36.4                                | 31.8                                | 28.3                                | 21.2                                | 144.7        | 1592       |
| 2200            | COMP 1               | 4.5                                 | 4.3                                 | 3.8                                 | 3.4                                 | 2.5                                 | 18.1         | 199        |
|                 | COMP 2               | 9                                   | 8.7                                 | 7.6                                 | 6.7                                 | 5.1                                 | 37.1         | 408        |
|                 | COMP 3               | 18.8                                | 18.2                                | 15.9                                | 14.1                                | 10.6                                | 72.3         | 796        |
|                 | COMP 4               | 37.7                                | 36.4                                | 31.8                                | 28.3                                | 21.2                                | 144.7        | 1592       |

[Table 7-4](#) shows the second zero frequency placement about two times based on a ratio ( $f_0/f_{SW}$ ) of the LC frequency ( $f_0$ ) to the switching frequency and lists the values in [Table 7-3](#). The second zero frequency does not change with the output voltage. The high frequency pole is about 10 times of the second zero frequency to attenuate the switching frequency noise and to have a safe gain margin.

The output filter LC frequency must be designed between the first and second zero frequencies. The ratio of the LC frequency to the switching frequency in [Table 7-4](#) is a guide to select the LC frequency  $f_0$ . For example, the LC frequency for 1-MHz switching frequency is 10 kHz at 1% ratio. Given 1-V output voltage, COMP2 has the first zero at 4.5 kHz to compensate the LC filter double poles. For the same LC filter and switching frequencies of 3.3-V output voltage, COMP3 has the first zero at 6.7 kHz to compensate the LC filter double poles. The compensation setting needs to consider for the output capacitor derating, especially ceramic capacitor, and inductor tolerance. It is recommended to verify the load transient and bode plot based upon the compensation selection.

**Table 7-4. Second Zero Frequency**

| $f_o/f_{sw}$ | COMPENSATION SETTING | SECOND ZERO FREQUENCY    |
|--------------|----------------------|--------------------------|
| 0.5%         | COMP 1               | ~2X of 0.5% $f_o/f_{sw}$ |
| 1%           | COMP 2               | ~2X of 1% $f_o/f_{sw}$   |
| 2%           | COMP 3               | ~2X of 2% $f_o/f_{sw}$   |
| 4%           | COMP 4               | ~2X of 4% $f_o/f_{sw}$   |

### 7.3.7 Soft Start and Prebiased Output Start-up

The TPS542A50 uses a programmable soft-start rate to gradually ramp the output voltage reference to reduce inrush currents. The device prevents current from being discharged from the output during start-up when a pre-biased condition exists. No switching pulses occur until the internal soft-start reference exceeds the voltage on the error amplifier input voltage (RSP and RSN pins). The TPS542A50 supports the output voltage with pre-biased up to 100%.

The soft-start clock in [Table 7-5](#) can be programmed on the SS/PFM pin along with enabling/disabling PFM and hiccup time. These same options can also be programmed through the I<sup>2</sup>C interface. The SS/PFM pin can be shorted to ground to reduce BOM component count. When shorted to ground the default soft-start slew rate is used, and PFM is disabled. If the user programs these functions frequently using the I<sup>2</sup>C interface, TI recommends shorting the SS/PFM pin to ground to reduce component count. The soft-start timing in [Table 7-6](#) can be programmed based upon the output voltage and soft-start clock. There are four choices of soft-start times to select different soft-start clocks. To prevent an OC fault trigger at start-up, it is recommended to increase the length of soft-start time to reduce the inrush current from exceeding the peak current limit. Using 1-V output voltage as an example, the soft-start time equals to 1.8 ms at 0.5-MHz SS CLK and 0.45 ms at 2.0-MHz SS CLK.

**Table 7-5. Soft-Start CLK and PFM Resistor Selection and Hiccup Time**

| R <sub>SS/PFM</sub> (k $\Omega$ ) | PFM     | SS CLK (MHz) | HICCUP DURATION (ms) |
|-----------------------------------|---------|--------------|----------------------|
| Short                             | Disable | 1.0          | 25.2                 |
| 7.5                               | Enable  | 2.0          | 12.6                 |
| 18.2                              |         | 1.0          | 25.2                 |
| 26.1                              |         | 0.50         | 50.4                 |
| 35.7                              |         | 0.25         | 100.8                |
| 47.5                              | Disable | 2.0          | 12.6                 |
| 61.9                              |         | 1.0          | 25.2                 |
| 78.7                              |         | 0.50         | 50.4                 |
| 102                               |         | 0.25         | 100.8                |

**Table 7-6. Soft-Start Timing versus Output Voltage**

| VSET (V) | VOUT (V) | LSB SIZE (mV) | SS TIMING (ms) AT<br>CLK: 2.0 MHz | SS TIMING (ms) AT<br>CLK: 1.0 MHz | SS TIMING (ms) AT<br>CLK: 0.5 MHz | SS TIMING (ms) AT<br>CLK: 0.25 MHz |
|----------|----------|---------------|-----------------------------------|-----------------------------------|-----------------------------------|------------------------------------|
| 0.1      | 0.5      | 0.112         | 0.45                              | 0.9                               | 1.8                               | 3.6                                |
| 0.2      | 1        | 0.223         | 0.45                              | 0.9                               | 1.8                               | 3.6                                |
| 0.28     | 1.4      | 0.313         | 0.45                              | 0.9                               | 1.8                               | 3.6                                |
| 0.3      | 1.5      | 0.167         | 0.9                               | 1.8                               | 3.6                               | 7.2                                |
| 0.4      | 2.0      | 0.223         | 0.9                               | 1.8                               | 3.6                               | 7.2                                |
| 0.5      | 2.5      | 0.279         | 0.9                               | 1.8                               | 3.6                               | 7.2                                |
| 0.56     | 2.8      | 0.313         | 0.9                               | 1.8                               | 3.6                               | 7.2                                |
| 0.6      | 3.0      | 0.167         | 1.8                               | 3.6                               | 7.2                               | 14.4                               |
| 0.7      | 3.5      | 0.195         | 1.8                               | 3.6                               | 7.2                               | 14.4                               |
| 0.8      | 4        | 0.223         | 1.8                               | 3.6                               | 7.2                               | 14.4                               |
| 0.9      | 4.5      | 0.251         | 1.8                               | 3.6                               | 7.2                               | 14.4                               |
| 1        | 5.0      | 0.279         | 1.8                               | 3.6                               | 7.2                               | 14.4                               |

### 7.3.8 Power Good

The power good pin is an open-drain output and needs to pull up to a voltage supply if a designer uses this feature. During normal converter operation, the device leaves this pin floating. Power good warnings occur if the output voltage is not within the OV or UV warning levels. Power Good (PGD) is forced low if OV or UV is exceeded, when the converter is in soft start, and when the converter is in shutdown or programming mode. The PGD pin is released to floating after the PGD delay time when all of the above conditions are met.

TI recommends connecting a pullup resistor to a voltage source that is 5.5 V or less, such as to the device VREG pin.

### 7.3.9 Overvoltage and Undervoltage Protection

An output overvoltage (OV) fault is triggered if the output voltage, sensed by RSP/RSN, is greater than the OVP trip level. When this condition is detected, the converter terminates the switching cycle and turns on the low-side FET to discharge the output voltage. The low-side FET remains on until the low-side FET current reaches the negative overcurrent limit. When the negative overcurrent limit is reached, the low set FET turns off for 2000 ns. After the 2000 ns delay, the low-side FET turns back on until the negative overcurrent limit is reached. This process repeats until the output voltage is discharged below the undervoltage fault threshold (typically 80% set  $V_{OUT}$ ). The converter then enters hiccup for seven cycles of soft-start CLK frequency due to the output voltage being below the UV threshold.

An output undervoltage fault is triggered if the output voltage, sensed by RSP/RSN, is less than UVP threshold. When this condition is detected, power conversion is disabled, and the converter enters hiccup for seven cycles of soft-start CLK frequency.

### 7.3.10 Overcurrent Protection

The device senses overcurrent (OC) in both the high-side and low-side power MOSFETs using cycle by cycle detection. OC is detected in the low-side FET by sensing the voltage across the FET while it is on. After the low-side FET turns on, there is a blanking time of approximately 70 ns to allow noise to settle before the OC comparator begins sensing. If the peak current limit is hit, then an OC fault condition is detected which causes the device to stop switching and enter hiccup for seven cycles of soft-start CLK frequency. The overcurrent limit is set through a single resistor to ground on the ILIM pin or through I<sup>2</sup>C programming. The ILIM pin can be shorted to ground to reduce BOM component count. When shorted to ground, the default current limit is used. If the user programs the current limit using the I<sup>2</sup>C interface, TI recommends shorting the ILIM pin to ground to reduce component count. Current limits shown in [Table 7-7](#) can be programmed on the ILIM pin.

**Table 7-7. Current Limit Resistor Selection**

| $R_{ILIM}$ (k $\Omega$ ) | TYPICAL LIMIT (A) |
|--------------------------|-------------------|
| Short                    | 20                |
| 7.5                      | 5.5               |
| 18.2                     | 8                 |
| 26.1                     | 10.5              |
| 35.7                     | 13                |
| 47.5                     | 16.5              |
| 61.9                     | 20                |

The device also senses negative overcurrent in the low-side FET by sensing the voltage across the FET while it is on. After the low-side FET turns on, there is a blanking time to allow noise to settle before the OC comparator begins sensing. Once a negative OC fault condition is detected, the device stops switching and enters hiccup for seven cycles of soft-start CLK frequency. The negative overcurrent threshold is fixed to a single value.

Overcurrent is detected in the high-side FET by sensing the voltage across the FET while it is on. After the high-side FET turns on, there is a blanking time to allow noise to settle before the OC comparator begins sensing. Once an OC fault condition is detected, the device stops switching and enters hiccup for seven cycles of soft-start CLK frequency. At start-up, the inrush current has the potential of exceeding the peak current limit, thereby causing the device to enter hiccup. To prevent an OC fault trigger at start-up, it is recommended to increase the soft-start time or decrease the load at the output to reduce the inrush current from exceeding the peak current limit. The high-side overcurrent threshold is fixed to a single value. For an application with on-time less than 70 ns, the high-side FET overcurrent is not guaranteed to enable. In this case, the low-side OC will dominate and protect the load while the output current ramps up gradually. With on-times less than 70 ns and a hard short at the load, the controller loop will extend the on-time to respond to the output voltage drooping, and as a result, both high-side and low-side OC protections will engage to protect the load.

### 7.3.11 High-Side FET Throttling

When the high-side FET turns on or off, the ringing voltage across the FET depends on the output current, loop inductance, and PCB parasitic inductance. To diminish the ringing voltage during turning on or off, the TPS542A50 reduces the gate driver strength when TPS542A50 detects PVIN higher than 14 V with 0.5-V hysteresis.

### 7.3.12 Overtemperature Protection

When the device senses a temperature above the thermal shutdown limit (typically 165°C), power conversion is disabled. The converter remains disabled until the temperature cools down to the thermal recovery limit (typically 150°C). At this point, the converter enters hiccup for seven cycles of soft-start CLK frequency.

## 7.4 Device Functional Modes

### 7.4.1 Pulse-Frequency Modulation Eco-mode™ Light Load Operation

When the SS/PFM pin is terminated with a 35.7-kΩ or lower resistance, the TPS542A50 operates in pulse-frequency modulation (PFM) for light load conditions to maintain high efficiency.

As the output current decreases from heavy-load conditions, the inductor current also decreases until the valley of the inductor current reaches zero amps, which is the boundary between continuous-conduction mode (CCM) and discontinuous-conduction mode (DCM). The synchronous MOSFET turns off when this zero inductor current is detected. As the load current decreases further, the converter runs in DCM. In DCM operation, the on-time is maintained to a level approximately the same as during CCM and the converter off-time is modulated to maintain the proper output voltage. For the application of 5-V input voltage, it is not recommended to operate in PFM due to the accuracy of the zero comparator which will be reduced because of the low input voltage.

### 7.4.2 Forced Continuous-Conduction Mode

When the SS/PFM pin is terminated with a 47.5-kΩ or higher resistance, the TPS542A50 operates in forced continuous conduction mode (FCCM) for all load currents. During FCCM, the switching frequency is set by an internal oscillator for which the frequency can either be selected by the FSEL pin, programmed through I<sup>2</sup>C, or synchronized to an external clock on the SYNC pin.

### 7.4.3 Soft Start

The TPS542A50 operates in FCCM during soft start regardless of the setting selected by the SS/PFM pin. If PFM is enabled by the SS/PFM pin, the PFM operation begins after PGD is asserted. The delay between soft start finishing and PGD being asserted is typically 500 μs. During the start-up, the TPS542A50 has the low-side current limit at 16.5 A when the OCP configures 20 A. However, if the OCP configures below 16.5 A such as 13 A, then the current limit during soft start sets to be at 13 A. To prevent an OC fault trigger at start-up, it is recommended to increase the length of soft-start time to reduce the inrush current from exceeding the peak current limit.

## 7.5 Programming

### 7.5.1 I<sup>2</sup>C Address Selection

The I<sup>2</sup>C address is selected by a single resistor to ground on the COMP pin. Note that this function is combined with setting the compensation value. Refer to [Table 7-8](#) for selecting a COMP pin resistor value for your application.

**Table 7-8. COMP Resistor Selection for I<sup>2</sup>C Address**

| R <sub>COMP</sub> (kΩ) | I <sup>2</sup> C ADDRESS |
|------------------------|--------------------------|
| ≤ 35.7                 | 0x60                     |
| ≥ 47.5                 | 0x61                     |

### 7.5.2 Powering Device Into Programming Mode

The TPS542A50 can be powered on into programming mode for pre-operation configuration by bringing the SYNC pin above the SYNC threshold. This wakes up the device from low-power shutdown mode and the I<sup>2</sup>C interface is active for communication. Once the device configuration is complete, the EN pin can be brought above the EN threshold to begin power conversion. After this, the SYNC pin can either be driven low, Hi-Z, or used to synchronize the switching frequency to an external clock.

### 7.5.3 Device Configuration

The device settings can be configured when in programming mode before the device begins power conversion. When in programming mode, the switching frequency, current limit, internal compensation, soft-start rate, and FCCM enable/disable can be configured. Once the voltage on the EN pin exceeds the EN threshold and power conversion begins, these registers are read only. Configuration settings will be lost if device is allowed to go back into low-power shutdown mode.

When the TPS542A50 detects an individual fault of OCP, OT, OV, or UV, the STATUS register (0x01) asserts a logic high or "1" in its respective bit field. The asserted fault bits will remain high even after the fault is removed. To clear the asserted fault bits, cycle power to the device, or write a logic high to the bit field of the STATUS register for the desired bits to be cleared. Bits can be cleared individually or all at once by writing "0xDE." In the case of both OCP and OT bits detection, they are designed to automatically clear one another. For example, in the case of an OCP fault followed by an OT fault, the OCP will initially assert a logic high, but when the OT is encountered, the OCP will automatically clear to a logic low or "0", and only the OT fault bit will remain asserted as a logic high. If the events are encountered in the reverse order, then only the OCP will remain asserted as a logic high and the OT fault bit will be cleared to a logic low.

### 7.5.4 Output Voltage Adjustment

The TPS542A50 output voltage can be adjusted in ~0.028% increments from -20% to +10% of the set output voltage. This function can only be performed after PGOOD goes high. During programming mode, these registers are read only.

For positive margin, write to 0x02 and 0x03 registers. Writing *only* to the 0x02 register does not adjust the output voltage. Writing to both registers, 0x02 and 0x03, *does* adjust the output voltage. Bits [7:3] of register 0x02 must be equal to 0000 for a positive output voltage adjustment. Bits [7:3] of register 0x02 must be 1111 for a negative output voltage adjustment.

- Writing 0x01 to 0x02 register and 0x66 to 0x03 register will margin the output voltage +10%. The output voltage will transition with a slew rate of soft start.
- Writing 0xFD to 0x02 register and 0x34 to 0x03 register will margin the output voltage -20%.
- Writing 0x01 to the 0x03 register will step the output voltage margin by one positive step. The 0x02 register does not have to be written for small positive steps.

### 7.6 Pin-Strap Programming

Table 7-9 and Table 7-10 provide the binary code for these pin-strap pins.

**Table 7-9. Pin-Strap Programming 1**

| R <sub>LIM</sub> (kΩ) | R <sub>FSEL</sub> (kΩ) | BINARY CODE |
|-----------------------|------------------------|-------------|
| 7.5                   | 7.5                    | 000         |
| 18.2                  | 18.2                   | 001         |
| 26.1                  | 26.1                   | 010         |
| 35.7                  | 35.7                   | 011         |
| 47.5                  | 47.5                   | 100         |
| 61.9                  | 61.9                   | 101         |
| N/A                   | 78.7                   | 110         |
| N/A                   | N/A                    | 111         |

**Table 7-10. Pin-Strap Programming 2**

| R <sub>SS/PFM</sub> (kΩ) | BINARY CODE | COMPENSATION SETTING | I <sup>2</sup> C ADDRESS | BINARY CODE |
|--------------------------|-------------|----------------------|--------------------------|-------------|
| 7.5                      | 00          | COMP 1               | 0x60                     | 00          |
| 18.2                     | 01          | COMP 2               |                          | 01          |
| 26.1                     | 10          | COMP 3               |                          | 10          |
| 35.7                     | 11          | COMP 4               |                          | 11          |
| 47.5                     | 00          | COMP 1               | 0x61                     | 00          |
| 61.9                     | 01          | COMP 2               |                          | 01          |
| 78.7                     | 10          | COMP 3               |                          | 10          |
| 102                      | 11          | COMP 4               |                          | 11          |

## 7.7 Register Maps

Table 7-11 lists the memory-mapped registers for the Device registers. All register offset addresses not listed in Table 7-11 should be considered as reserved locations and the register contents should not be modified.

**Table 7-11. Device Registers**

| Offset | Acronym   | Register Name | Section            |
|--------|-----------|---------------|--------------------|
| 0x0    | ID        |               | <a href="#">Go</a> |
| 0x1    | STATUS    |               | <a href="#">Go</a> |
| 0x2    | VOUT_ADJ1 |               | <a href="#">Go</a> |
| 0x3    | VOUT_ADJ2 |               | <a href="#">Go</a> |
| 0x4    | CONFIG1   |               | <a href="#">Go</a> |
| 0x5    | CONFIG2   |               | <a href="#">Go</a> |

Complex bit access types are encoded to fit into small table cells. Table 7-12 shows the codes that are used for access types in this section.

**Table 7-12. Device Access Type Codes**

| Access Type            | Code | Description                            |
|------------------------|------|--|
| Read Type              |      |  |
| R                      | R    | Read                                   |
| Write Type             |      |  |
| W                      | W    | Write                                  |
| Reset or Default Value |      |  |
| -n                     |      | Value after reset or the default value |

### 7.7.1 ID Register (Offset = 0x0) [reset = 0x21]

ID is shown in Figure 7-2 and described in Table 7-13.

Return to [Summary Table](#).

**Figure 7-2. ID Register**

|             |   |   |   |   |   |   |   |
|-------------|---|---|---|---|---|---|---|
| 7           | 6 | 5 | 4 | 3 | 2 | 1 | 0 |
| IC_Revision |   |   |   |   |   |   |   |
| R-0x21      |   |   |   |   |   |   |   |

**Table 7-13. ID Register Field Descriptions**

| Bit | Field       | Type | Reset | Description |
|-----|-------------|------|-------|-------------|
| 7-0 | IC_Revision | R    | 0x21  | IC Revision |

### 7.7.2 STATUS Register (Offset = 0x1) [reset = 0x0]

STATUS is shown in Figure 7-3 and described in Table 7-14.

Return to [Summary Table](#).

**Figure 7-3. STATUS Register**

|          |   |   |          |          |          |          |         |
|----------|---|---|----------|----------|----------|----------|---------|
| 7        | 6 | 5 | 4        | 3        | 2        | 1        | 0       |
| RESERVED |   |   | OT_FAULT | OC_FAULT | OV_FAULT | UV_FAULT | PGOOD   |
| R-0x0    |   |   | R/W-0x0  | R/W-0x0  | R/W-0x0  | R/W-0x0  | R/W-0x0 |

**Table 7-14. STATUS Register Field Descriptions**

| Bit | Field    | Type | Reset | Description                    |
|-----|----------|------|-------|--------------------------------|
| 7-5 | RESERVED | R    | 0x0   | Reserved                       |
| 4   | OT_FAULT | R/W  | 0x0   | Overtemperature Fault Flag     |
| 3   | OC_FAULT | R/W  | 0x0   | Overcurrent Fault Flag         |
| 2   | OV_FAULT | R/W  | 0x0   | Output Overvoltage Fault Flag  |
| 1   | UV_FAULT | R/W  | 0x0   | Output Undervoltage Fault Flag |
| 0   | PGOOD    | R/W  | 0x0   | Power Good Indicator           |

**7.7.3 VOUT\_ADJ1 Register (Offset = 0x2) [reset = 0x0]**

VOUT\_ADJ1 is shown in [Figure 7-4](#) and described in [Table 7-15](#).

Return to [Summary Table](#).

**Figure 7-4. VOUT\_ADJ1 Register**

| 7        | 6 | 5 | 4 | 3        | 2 | 1 | 0 |
|----------|---|---|---|----------|---|---|---|
| RESERVED |   |   |   | VOUT_ADJ |   |   |   |
| R/W-0x0  |   |   |   | R/W-0x0  |   |   |   |

**Table 7-15. VOUT\_ADJ1 Register Field Descriptions**

| Bit | Field    | Type | Reset | Description                                     |
|-----|----------|------|-------|---|
| 7-4 | RESERVED | R/W  | 0x0   | Reserved  |
| 3-0 | VOUT_ADJ | R/W  | 0x0   | Output Voltage Adjustment Most Significant Bits |

For the command to work, bits [7:4] must match bit 3. For example, bit [7:4] = 0000 then bit 3 must equal 0. Otherwise, no changes are made.

**7.7.4 VOUT\_ADJ2 Register (Offset = 0x3) [reset = 0x0]**

VOUT\_ADJ2 is shown in [Figure 7-5](#) and described in [Table 7-16](#).

Return to [Summary Table](#).

**Figure 7-5. VOUT\_ADJ2 Register**

| 7        | 6 | 5 | 4 | 3 | 2 | 1 | 0 |
|----------|---|---|---|---|---|---|---|
| VOUT_ADJ |   |   |   |   |   |   |   |
| R/W-0x0  |   |   |   |   |   |   |   |

**Table 7-16. VOUT\_ADJ2 Register Field Descriptions**

| Bit | Field    | Type | Reset | Description                                      |
|-----|----------|------|-------|--|
| 7-0 | VOUT_ADJ | R/W  | 0x0   | Output Voltage Adjustment Least Significant Bits |

**7.7.5 CONFIG1 Register (Offset = 0x4) [reset = 0x0B]**

CONFIG1 is shown in [Figure 7-6](#) and described in [Table 7-17](#).

Return to [Summary Table](#).

**Figure 7-6. CONFIG1 Register**

| 7        | 6        | 5        | 4       | 3 | 2       | 1 | 0 |
|----------|----------|----------|---------|---|---------|---|---|
| RESERVED | RESERVED | RESERVED | COMP    |   | FSW     |   |   |
| R-0x0    | R-0x0    | R-0x0    | R/W-0x1 |   | R/W-0x3 |   |   |



**Table 7-17. CONFIG1 Register Field Descriptions**

| Bit | Field    | Type | Reset | Description           |
|-----|----------|------|-------|-----------------------|
| 7   | RESERVED | R    | 0x0   | Reserved              |
| 6   | RESERVED | R    | 0x0   | Reserved              |
| 5   | RESERVED | R    | 0x0   | Reserved              |
| 4-3 | COMP     | R/W  | 0x1   | Internal Compensation |
| 2-0 | FSW      | R/W  | 0x3   | Switching Frequency   |

### 7.7.6 CONFIG2 Register (Offset = 0x5) [reset = 0x2D]

CONFIG2 is shown in [Figure 7-7](#) and described in [Table 7-18](#).

Return to [Summary Table](#).

**Figure 7-7. CONFIG2 Register**

|          |   |         |   |         |   |         |   |
|----------|---|---------|---|---------|---|---------|---|
| 7        | 6 | 5       | 4 | 3       | 2 | 1       | 0 |
| RESERVED |   | ILIM    |   | FCCM    |   | SS      |   |
| R-0x0    |   | R/W-0x3 |   | R/W-0x1 |   | R/W-0x1 |   |

**Table 7-18. CONFIG2 Register Field Descriptions**

| Bit | Field    | Type | Reset | Description                      |
|-----|----------|------|-------|----------------------------------|
| 7-6 | RESERVED | R    | 0x0   | Reserved                         |
| 5-3 | ILIM     | R/W  | 0x3   | Overcurrent Limit                |
| 2   | FCCM     | R/W  | 0x1   | Force Continuous Conduction Mode |
| 1-0 | SS       | R/W  | 0x1   | Soft Start Rate                  |

## 8 Application and Implementation

### Note

Information in the following applications sections is not part of the TI component specification, and TI does not warrant its accuracy or completeness. TI's customers are responsible for determining suitability of components for their purposes, as well as validating and testing their design implementation to confirm system functionality.

### 8.1 Application Information

The TPS542A50 is a high-efficiency, single-channel, synchronous buck converter with integrated n-channel MOSFETs. The device suits low-output voltage point-of-load applications with 15-A or lower current. The TPS542A50 has a maximum operating junction temperature of 150°C, which makes it suitable for high-ambient temperature applications such as wireless infrastructure. The input voltage range is 4 V to 18 V, and the output voltage range is 0.5 V to 5.5 V. The device features a fixed-frequency voltage-control mode with a switching frequency range of 400 kHz to 2.2 MHz, allowing for efficiency and size optimization when selecting output filter components. The controller features selectable internal compensation making the device easy to use with a low external-component count. The internal compensation networks are able to support a wide range of output inductance and capacitance, supporting all types of capacitors. The controller utilizes a digital PWM modulator that allows for very narrow on-times making it ideal for high-frequency and high-step down ratio applications. The switching frequency of the device can be synchronized to an external clock applied to the SYNC pin. The TPS542A50 also features an I<sup>2</sup>C interface for device configuration and output voltage adjustments.

### 8.2 Typical Application

#### 8.2.1 Full Analog Configuration

A resistor to ground on the FSEL, COMP, SS/PFM, and ILIM pins configure the device. Any of these pins can be grounded to use the default values and reduce component count.

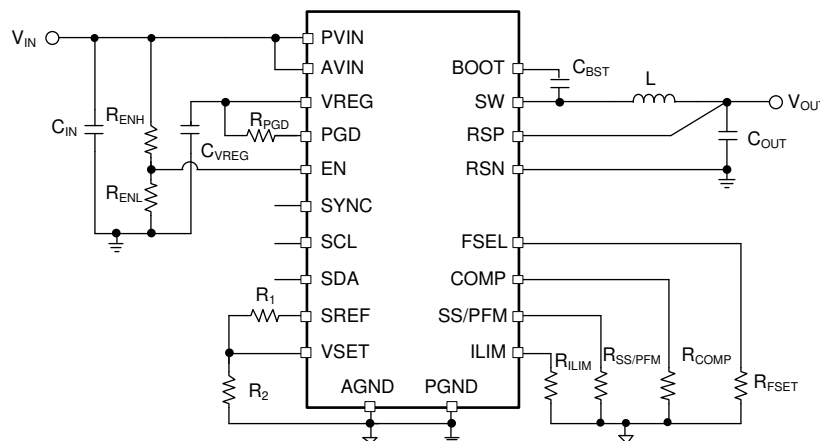

Figure 8-1. Full Analog Configuration

#### 8.2.1.1 Design Requirements

For this design example, use the input parameters shown in [Table 8-1](#).

Table 8-1. Design Example Specifications

| PARAMETER                                      | TEST CONDITION | MIN | TYP | MAX | UNIT |
|--|----------------|-----|-----|-----|------|
| V <sub>IN</sub> , Input Voltage                |                | 9   | 12  | 14  | V    |
| V <sub>IN(ripple)</sub> , Input Ripple Voltage |                |     |     | 0.2 | V    |
| V <sub>OUT</sub> , Output Voltage              |                |     | 1   |     | V    |
| V <sub>PP</sub> , Output Ripple Voltage        |                |     | 15  |     | mV   |

**Table 8-1. Design Example Specifications (continued)**

| PARAMETER  | TEST CONDITION                    | MIN | TYP | MAX | UNIT |
|--|-----------------------------------|-----|-----|-----|------|
| V <sub>OVER</sub> , Transient Response Overshoot   | I <sub>STEP</sub> = 5 A at 1 A/μs |     | 30  |     | mV   |
| V <sub>UNDER</sub> , Transient Response Undershoot | I <sub>STEP</sub> = 5 A at 1 A/μs |     | 30  |     | mV   |
| I <sub>OUT</sub> , Output Current                  |                                   |     | 10  |     | A    |
| I <sub>OC</sub> , Over-Current Trip Point          |                                   |     | 16  |     | A    |
| F <sub>SW</sub> , Switching Frequency              |                                   |     | 1.2 |     | MHz  |
| t <sub>SS</sub> , Soft-start time                  |                                   |     | 0.5 |     | ms   |

### 8.2.1.2 Detailed Design Procedure

#### 8.2.1.2.1 Custom Design With WEBENCH® Tools

[Click here](#) to create a custom design using the TPS542A50 device with the WEBENCH® Power Designer.

1. Start by entering the input voltage (V<sub>IN</sub>), output voltage (V<sub>OUT</sub>), and output current (I<sub>OUT</sub>) requirements.
2. Optimize the design for key parameters such as efficiency, footprint, and cost using the optimizer dial.
3. Compare the generated design with other possible solutions from Texas Instruments.

The WEBENCH Power Designer provides a customized schematic along with a list of materials with real-time pricing and component availability.

In most cases, these actions are available:

- Run electrical simulations to see important waveforms and circuit performance
- Run thermal simulations to understand board thermal performance
- Export customized schematic and layout into popular CAD formats
- Print PDF reports for the design, and share the design with colleagues

Get more information about WEBENCH tools at [www.ti.com/WEBENCH](http://www.ti.com/WEBENCH).

#### 8.2.1.2.2 Output Voltage Calculation

The output voltage equals five times of VSET. To set VSET voltage, a resistor divider network is required from SREF (1.2 V). [Equation 2](#) shows the output voltage calculation. It is recommended to use R<sub>1</sub> and R<sub>2</sub> in the range of 1 kΩ to 100 kΩ with a resistance-tolerance of 0.1% for best accuracy and that the total impedance of this divider network be > 6 kΩ. For example, R<sub>1</sub> equals 50 kΩ and R<sub>2</sub> equals 10 kΩ for 1-V output voltage.

$$V_{OUT} = 5 \times V_{SET}$$

$$V_{SET} = \frac{R_2}{R_1 + R_2} \times 1.2$$

$$V_{OUT} = 5 \times \frac{R_2}{R_1 + R_2} \times 1.2 \tag{2}$$

#### 8.2.1.2.3 Switching Frequency Selection

There is a trade off between higher and lower switching frequencies. Higher switching frequencies can produce a smaller solution size using lower valued inductors and smaller output capacitors compared to a power supply that switches at a lower frequency. However, the higher switching frequency causes extra switching losses, which decreases efficiency and impacts thermal performance. In this design, a moderate switching frequency of 1.2 MHz that achieves both a small solution size and a high efficiency operation is selected. TPS542A50 offers seven choices of switching frequency in [Table 7-1](#). RFSET equals to 47.5 kΩ for 1.2-MHz switching frequency.

#### 8.2.1.2.4 Inductor Selection

The inductor value is a compromise between having a good load step transient response, output ripple voltage, and efficiency. A good practice is to select the inductor ripple current value between 15% to 50% of the maximum output current. The output capacitor absorbs the inductor-ripple current. Therefore, selecting a high inductor-ripple current impacts the selection of the output capacitor because the output capacitor must have

a ripple-current rating equal to or greater than the inductor-ripple current. Using 35% target ripple current, the required inductor size can be calculated as shown in [Equation 3](#).

$$L = \frac{V_{OUT} \times (V_{IN} - V_{OUT})}{V_{IN} \times f_{SW} \times I_{OUT} \times 0.35} = \frac{1.0 \text{ V} \times (12 \text{ V} - 1.0 \text{ V})}{12 \text{ V} \times 1.2 \text{ MHz} \times 10 \text{ A} \times 0.35} = 218 \text{ nH} \quad (3)$$

A standard inductor value of 220 nH is selected.

#### 8.2.1.2.5 Input Capacitor Selection

The TPS542A50 requires a high-quality, ceramic, type X5R or X7R, input decoupling capacitor with a value of at least 1  $\mu\text{F}$  of effective capacitance on the PVIN pin, relative to PGND. The power stage input decoupling capacitance (effective capacitance at the PVIN and PGND pins) must be sufficient to supply the high switching currents demanded when the high-side MOSFET switches on, while providing minimal input voltage ripple as a result. This effective capacitance includes any DC bias effects. The voltage rating of the input capacitor must be greater than the maximum input voltage. The capacitor must also have a ripple current rating greater than the maximum input current ripple to the device during full load. The input ripple current can be calculated by [Equation 4](#).

$$I_{CIN(rms)} = I_{OUT(max)} \times \sqrt{\frac{V_{OUT}}{V_{IN}} \times \frac{(V_{IN} - V_{OUT})}{V_{IN}}} = 2.8 \text{ Amps} \quad (4)$$

The minimum input capacitance and ESR values for a given input voltage ripple specification,  $V_{IN(ripple)}$ , are shown in [Equation 5](#). The input ripple is composed of a capacitive portion,  $V_{IN(RIPPLE\_CAP)}$ , and a resistive portion,  $V_{IN(RIPPLE\_ESR)}$ .

$$C_{IN(min)} = \frac{I_{OUT(max)} \times (1 - D) \times D}{V_{IN(RIPPLE\_CAP)} \times f_{SW}} = 6.4 \mu\text{F}$$

$$ESR_{CIN(max)} = \frac{V_{IN(RIPPLE\_ESR)}}{I_{OUT(max)} + \frac{I_{RIPPLE}}{2}} = 8.5 \text{ m}\Omega$$

where

- D is the duty cycle (5)

The value of a ceramic capacitor varies significantly over temperature and the amount of DC bias applied to the capacitor. The capacitance variations due to temperature can be minimized by selecting a dielectric material that is stable over temperature. X5R and X7R ceramic dielectrics are usually selected for power regulator capacitors because they have a high capacitance to volume ratio and are fairly stable over temperature. The input capacitor must also be selected with the DC bias taken into account. For this example design, a ceramic capacitor with at least a 25-V voltage rating is required to support the maximum input voltage. For this design, allow 0.1-V input ripple for  $V_{IN(RIPPLE\_CAP)}$ , and 0.1-V input ripple for  $V_{IN(RIPPLE\_ESR)}$ . Using [Equation 5](#), the minimum input capacitance for this design is 6.4  $\mu\text{F}$ , and the maximum ESR is 8.5 m $\Omega$ . In a real application, it is recommended to use a combination of small capacitors such as 0.1  $\mu\text{F}$  and larger value 10- $\mu\text{F}$  or 22- $\mu\text{F}$  ceramic capacitors in parallel for the power stage.

#### 8.2.1.2.6 Bootstrap Capacitor Selection

A ceramic capacitor with a value of 0.1  $\mu\text{F}$  must be connected between the BOOT and SW pins for proper operation. It is recommended to use a ceramic capacitor with X5R or better grade dielectric. Use a capacitor with a voltage rating of 25 V or higher.

#### 8.2.1.2.7 R-C Snubber and VIN Pin High-Frequency Bypass

Though it is possible to operate the TPS542A50 within absolute maximum ratings without voltage ringing reduction techniques, some designs may require external components to further reduce ringing levels. This example uses two approaches: a high frequency power stage bypass capacitor on the VIN pins, and an R-C snubber between the SW area and GND.

The high-frequency VIN bypass capacitor is a lossless ringing reduction technique which helps minimize the outboard parasitic inductances in the power stage, which store energy during the high-side MOSFET on-time, and discharge once the high-side MOSFET is turned off. For this example two of 0.1-μF to 1-μF, 25-V, 0402-sized high-frequency capacitors are used. The placement of these capacitors is critical to its effectiveness.

Additionally, an optional R-C snubber circuit is added to this example. To balance efficiency and spike levels, a 220-pF capacitor and a 2-Ω resistor are chosen. In this example, a 0805-sized resistor is chosen, which is rated for 0.125 W, nearly twice the estimated power dissipation. It is recommended for the R-C snubber circuit to sustain the ringing levels 2-V below the absolute maximum ratings at room temperature. See the [Seminar 900 Topic 2 - Snubber Circuits: Theory, Design and Application](#) application note for more information about snubber circuits.

#### 8.2.1.2.8 Output Capacitor Selection

There are three primary considerations for selecting the value of the output capacitor. The output capacitor affects three criteria:

- Stability
- Regulator response to a change in load current or load transient
- Output voltage ripple

These three considerations are important when designing regulators that must operate where the electrical conditions are unpredictable. The output capacitance needs to be selected based on the most stringent of these three criteria.

#### 8.2.1.2.9 Response to a Load Transient

The output capacitance must supply the load with the required current when current is not immediately provided by the regulator. When the output capacitor supplies load current, the impedance of the capacitor greatly affects the magnitude of voltage deviation (such as undershoot and overshoot) during the transient.

Use [Equation 6](#) and [Equation 7](#) to calculate the minimum output capacitance to meet the undershoot and overshoot requirements. For this example, C<sub>OUT(min\_undershoot)</sub> is 136 μF and 92 μF for C<sub>OUT(min\_overshoot)</sub>. In a real application, the value of a ceramic capacitor varies significantly over temperature and the amount of DC bias applied to the capacitor. It is recommended to check the capacitor datasheet and account for the capacitance derating.

$$C_{OUT(min\_undershoot)} = \frac{L \times \Delta I_{LOAD(max)}^2}{2 \times \Delta V_{LOAD(insert)} \times (V_{IN} - V_{OUT})} + \frac{\Delta I_{LOAD(max)} \times (1 - D) \times t_{SW}}{\Delta V_{LOAD(insert)}} \quad (6)$$

$$C_{OUT(min\_overshoot)} = \frac{L_{OUT} \times (\Delta I_{LOAD(max)})^2}{2 \times \Delta V_{LOAD(release)} \times V_{OUT}} \quad (7)$$

where

- C<sub>OUT(min\_undershoot)</sub> is the minimum output capacitance to meet the undershoot requirement
- C<sub>OUT(min\_overshoot)</sub> is the minimum output capacitance to meet the overshoot requirement
- D is the duty cycle
- L is the output inductance value (0.22 μH)
- ΔI<sub>LOAD(max)</sub> is the maximum transient step (5 A)
- V<sub>OUT</sub> is the output voltage value (1 V)
- t<sub>SW</sub> is the switching period (0.833 μs)
- V<sub>IN</sub> is the minimum input voltage for the design (12 V)
- ΔV<sub>LOAD(insert)</sub> is the undershoot requirement (30 mV)
- ΔV<sub>LOAD(release)</sub> is the overshoot requirement (30 mV)

TPS542A50

SNVSB00C – SEPTEMBER 2020 – REVISED DECEMBER 2021

8.2.1.2.10 Pin-Strap Setting

For overcurrent protection at 16.5 A, 47.5 kΩ is chosen from Table 7-7. For 0.5-ms soft start and FCCM operation, 47.5 kΩ is chosen from Table 7-5 and Table 7-6.

For converter stability and selecting the compensation network, Table 7-3 provides four compensation choices. First, the power stage double pole filter frequency needs to be known. For this example, the output capacitor bank selects as 4x100-μF ceramic capacitors in 0805 size to account the capacitor de-rate factors. Next, the LC filter frequency is calculated to 17 kHz. Finally, COMP3 becomes the best choice to select by using a 26.1-kΩ or 78.7-kΩ resistor on the COMP pin to GND.

8.2.1.3 Application Curves

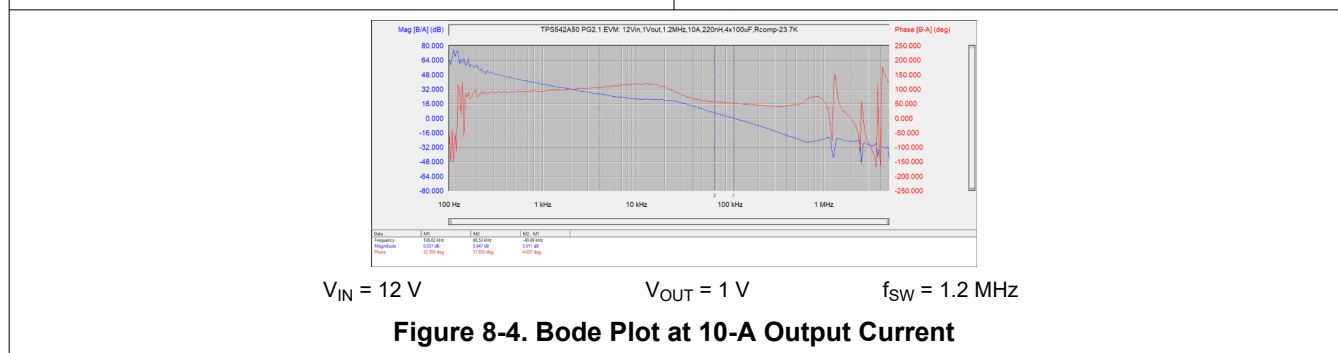
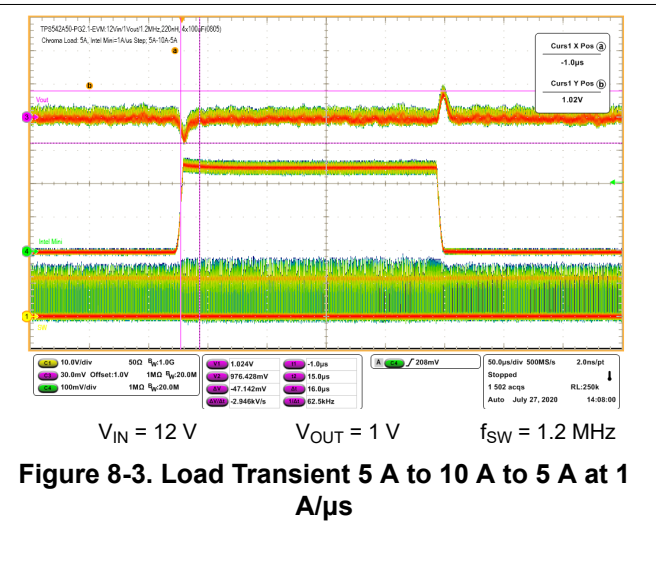
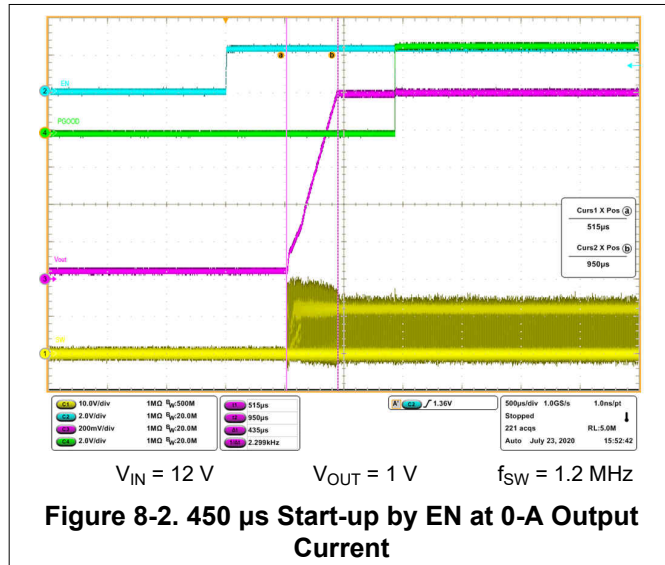

### 8.2.1.4 Typical Application Circuits

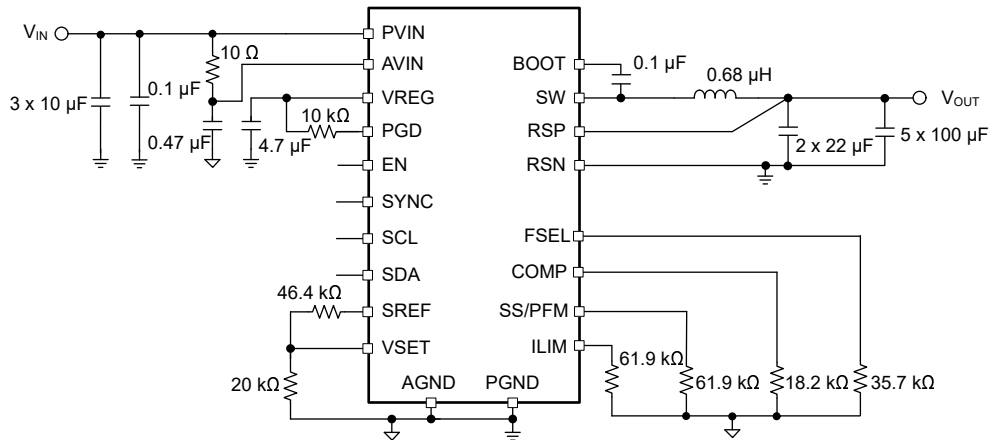

**Figure 8-5. Typical Application Circuit for 1.8-V Output at 1.0 MHz**

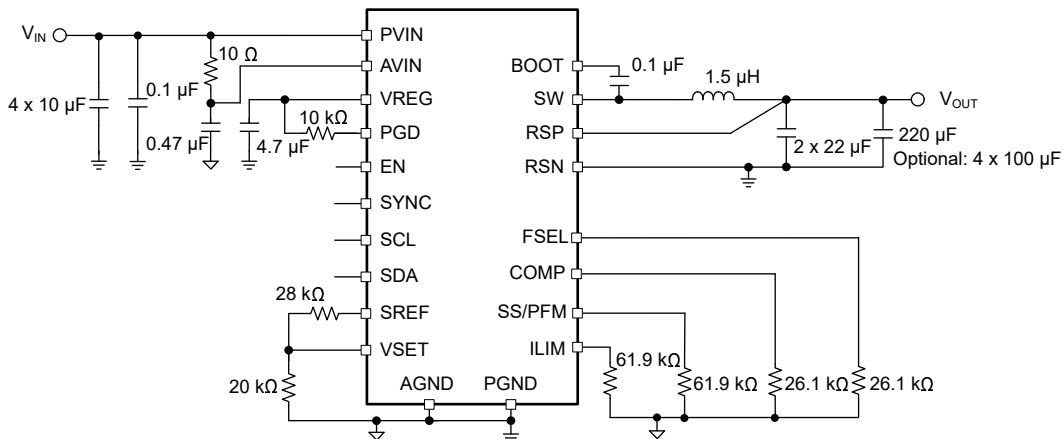

**Figure 8-6. Typical Application Circuit for 2.5-V Output at 0.8 MHz**

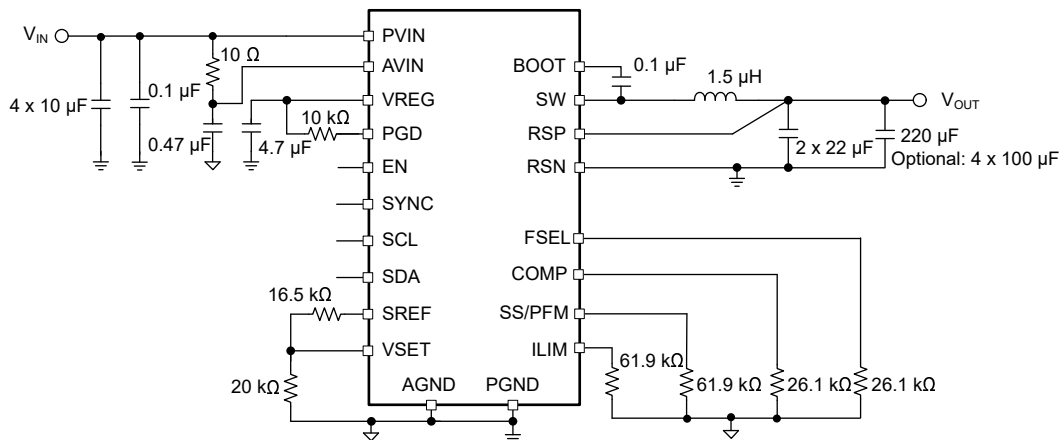

**Figure 8-7. Typical Application Circuit for 3.3-V Output at 0.8 MHz**

**TPS542A50**

SNVSB00C – SEPTEMBER 2020 – REVISED DECEMBER 2021

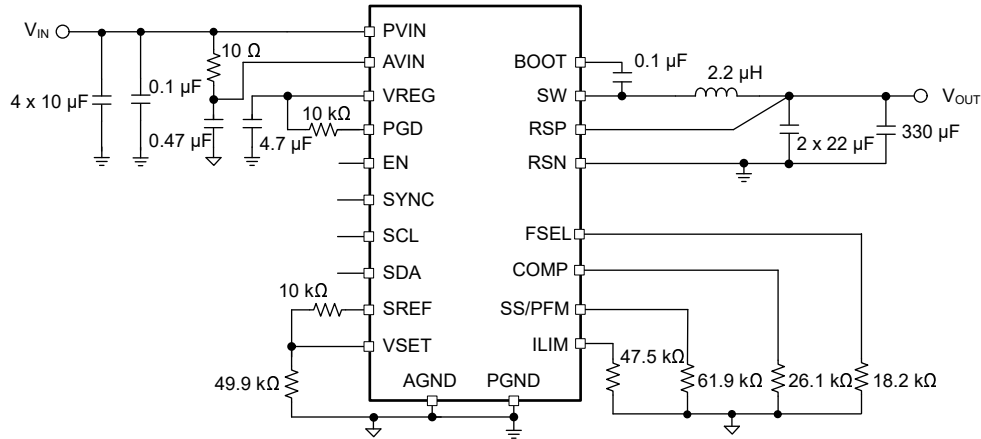

**Figure 8-8. Typical Application Circuit for 5-V Output at 0.6 MHz**

### 9 Power Supply Recommendations

The device is designed to operate from an input voltage supply range between 4 V and 18 V. This input supply must be well regulated. Proper bypassing of input supplies (AVIN and PVIN) is critical for noise performance, as is the PCB layout and grounding scheme. See the recommendations in [Section 10](#).



## 10 Layout

### 10.1 Layout Guidelines

- The PVIN pins are the power inputs to the main half bridge and AVIN is the power input to the controller.
- Connect AVIN and PVIN together on the PCB. It is important that these pins are at the same voltage potential because the controller feedforward block uses this voltage information in the modulator to increase transient performance. For AVIN, it is best to use RC filter from PVIN such as 10-Ω and 100 nF.
- To minimize the power loop inductance for the half bridge, place the bypassing capacitors as close as possible to the PVIN pins on the converter. When using a multilayer PCB (more than two layers), the power loop inductance is minimized by having the return path to the input capacitor small and directly underneath the first layer as shown below. Loop inductance is reduced due to flux cancellation as the return current is directly underneath and flowing in the opposite direction.
- Place the bias capacitor for VREG pin as close as possible to the pin as shown below.
- The resistor divider network for SREF and VSET needs to be placed as close as possible to the pins. Limit the high frequency noise source coupling onto these components.
- RSP and RSN signals are best to route parallel to the load sense location. It is recommended to limit high frequency noise source coupling onto these traces.
- PGND thermal vias: It is recommended to add vias under and outside the IC of PGND plane as shown below.
- AGND thermal vias: It is recommended to add at least two vias under the IC of AGND plane as shown below.
- AGND plane can be routed as a separate island in an internal layer. AGND can connect as a net tied to PGND between the two thermal grounds under the IC as shown below.
- Total PCB area can be routed in 17 mm by 14 mm as shown below. See the [Using the TPS542A50EVM-059](#) user's guide for more details.

## 10.2 Layout Example

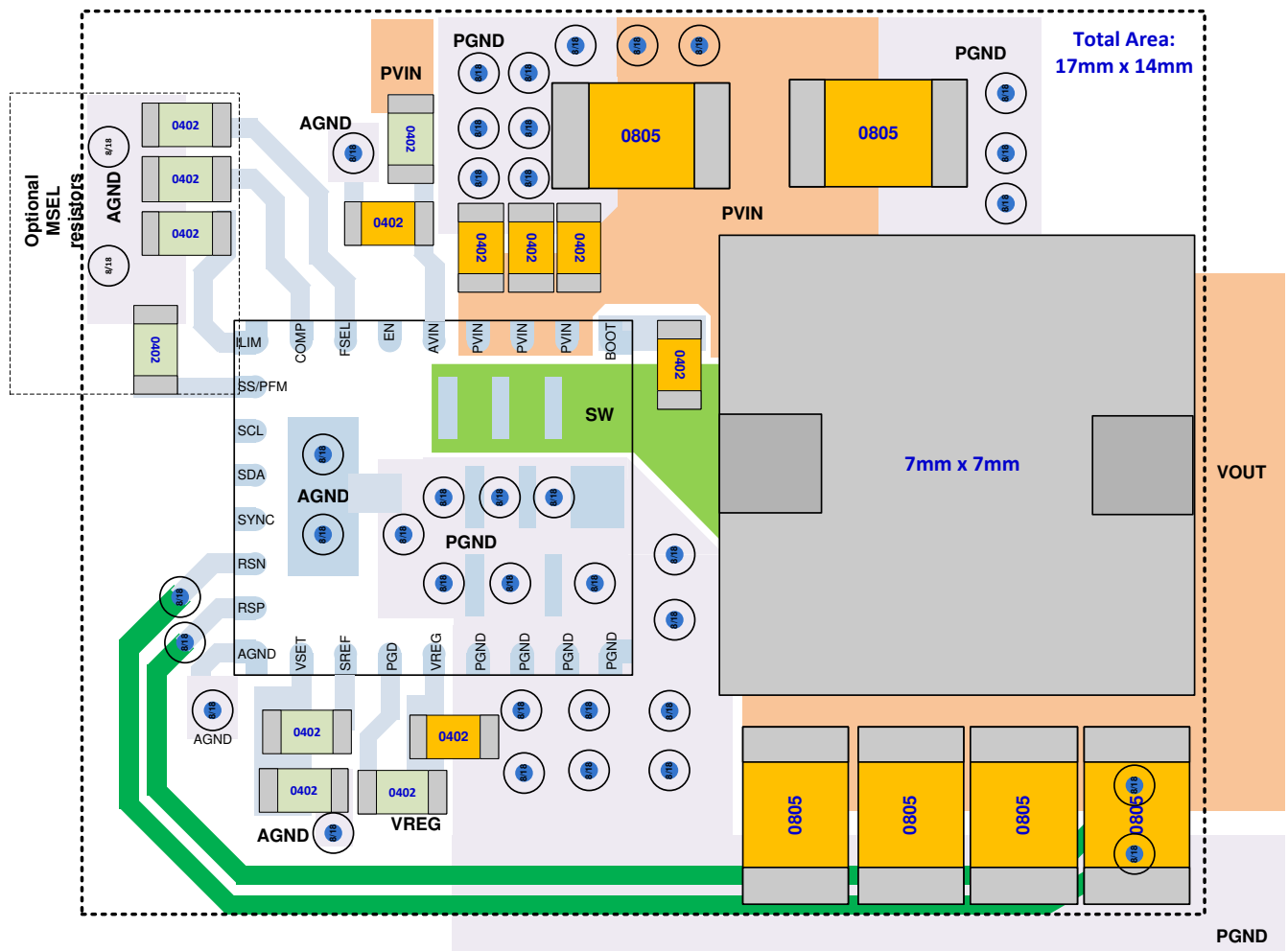

Figure 10-1. Example PCB Layout

## 11 Device and Documentation Support

### 11.1 Device Support

#### 11.1.1 Development Support

##### 11.1.1.1 Fusion Digital Power™ Designer Tool

[Click here](#) to download the Graphical User Interface (GUI) used to configure and monitor the TPS542A50 with the Fusion Digital Power™ designer.

The Fusion Digital Power™ designer uses the PMBus protocol to communicate with the device over serial bus by way of a TI USB adapter.

Some of the tasks you can perform with the GUI include:

- Turn on or off the power supply output, either through hardware control line or the PMBus OPERATION command.
- Monitor real-time data. Items such as input voltage, output voltage, output current, temperature, and warnings/faults are continuously monitored and displayed by the GUI.

Get more information about the software tool at [www.ti.com/tool/FUSION\\_DIGITAL\\_POWER\\_DESIGNER](http://www.ti.com/tool/FUSION_DIGITAL_POWER_DESIGNER).

##### 11.1.1.2 Custom Design With WEBENCH® Tools

[Click here](#) to create a custom design using the TPS542A50 device with the WEBENCH® Power Designer.

1. Start by entering the input voltage ( $V_{IN}$ ), output voltage ( $V_{OUT}$ ), and output current ( $I_{OUT}$ ) requirements.
2. Optimize the design for key parameters such as efficiency, footprint, and cost using the optimizer dial.
3. Compare the generated design with other possible solutions from Texas Instruments.

The WEBENCH Power Designer provides a customized schematic along with a list of materials with real-time pricing and component availability.

In most cases, these actions are available:

- Run electrical simulations to see important waveforms and circuit performance
- Run thermal simulations to understand board thermal performance
- Export customized schematic and layout into popular CAD formats
- Print PDF reports for the design, and share the design with colleagues

Get more information about WEBENCH tools at [www.ti.com/WEBENCH](http://www.ti.com/WEBENCH).

### 11.2 Receiving Notification of Documentation Updates

To receive notification of documentation updates, navigate to the device product folder on [ti.com](http://ti.com). Click on *Subscribe to updates* to register and receive a weekly digest of any product information that has changed. For change details, review the revision history included in any revised document.

### 11.3 Support Resources

[TI E2E™ support forums](#) are an engineer's go-to source for fast, verified answers and design help — straight from the experts. Search existing answers or ask your own question to get the quick design help you need.

Linked content is provided "AS IS" by the respective contributors. They do not constitute TI specifications and do not necessarily reflect TI's views; see TI's [Terms of Use](#).

### 11.4 Trademarks

Eco-mode™ and TI E2E™ are trademarks of Texas Instruments.

WEBENCH® is a registered trademark of Texas Instruments.

All trademarks are the property of their respective owners.

## 11.5 Electrostatic Discharge Caution



This integrated circuit can be damaged by ESD. Texas Instruments recommends that all integrated circuits be handled with appropriate precautions. Failure to observe proper handling and installation procedures can cause damage.

ESD damage can range from subtle performance degradation to complete device failure. Precision integrated circuits may be more susceptible to damage because very small parametric changes could cause the device not to meet its published specifications.

## 11.6 Glossary

### [TI Glossary](#)

This glossary lists and explains terms, acronyms, and definitions.

## 12 Mechanical, Packaging, and Orderable Information

The following pages include mechanical, packaging, and orderable information. This information is the most current data available for the designated devices. This data is subject to change without notice and revision of this document. For browser-based versions of this data sheet, refer to the left-hand navigation.

## PACKAGING INFORMATION

| Orderable part number         | Status<br>(1) | Material type<br>(2) | Package   Pins     | Package qty   Carrier | RoHS<br>(3) | Lead finish/<br>Ball material<br>(4) | MSL rating/<br>Peak reflow<br>(5) | Op temp (°C) | Part marking<br>(6) |
|-------------------------------|---------------|----------------------|--------------------|-----------------------|-------------|--------------------------------------|-----------------------------------|--------------|---------------------|
| <a href="#">TPS542A50RJMR</a> | Active        | Production           | VQFN-HR (RJM)   33 | 3000   LARGE T&R      | Yes         | NIPDAU                               | Level-2-260C-1 YEAR               | -40 to 150   | 542A50              |
| TPS542A50RJMR.A               | Active        | Production           | VQFN-HR (RJM)   33 | 3000   LARGE T&R      | Yes         | NIPDAU                               | Level-2-260C-1 YEAR               | -40 to 150   | 542A50              |
| TPS542A50RJMR.B               | Active        | Production           | VQFN-HR (RJM)   33 | 3000   LARGE T&R      | -           | Call TI                              | Call TI                           | -40 to 150   |                     |
| TPS542A50RJMRG4               | Active        | Production           | VQFN-HR (RJM)   33 | 3000   LARGE T&R      | Yes         | NIPDAU                               | Level-2-260C-1 YEAR               | -40 to 150   | 542A50              |
| TPS542A50RJMRG4.A             | Active        | Production           | VQFN-HR (RJM)   33 | 3000   LARGE T&R      | Yes         | NIPDAU                               | Level-2-260C-1 YEAR               | -40 to 150   | 542A50              |
| TPS542A50RJMRG4.B             | Active        | Production           | VQFN-HR (RJM)   33 | 3000   LARGE T&R      | -           | Call TI                              | Call TI                           | -40 to 150   |                     |

(1) **Status:** For more details on status, see our [product life cycle](#).

(2) **Material type:** When designated, preproduction parts are prototypes/experimental devices, and are not yet approved or released for full production. Testing and final process, including without limitation quality assurance, reliability performance testing, and/or process qualification, may not yet be complete, and this item is subject to further changes or possible discontinuation. If available for ordering, purchases will be subject to an additional waiver at checkout, and are intended for early internal evaluation purposes only. These items are sold without warranties of any kind.

(3) **RoHS values:** Yes, No, RoHS Exempt. See the [TI RoHS Statement](#) for additional information and value definition.

(4) **Lead finish/Ball material:** Parts may have multiple material finish options. Finish options are separated by a vertical ruled line. Lead finish/Ball material values may wrap to two lines if the finish value exceeds the maximum column width.

(5) **MSL rating/Peak reflow:** The moisture sensitivity level ratings and peak solder (reflow) temperatures. In the event that a part has multiple moisture sensitivity ratings, only the lowest level per JEDEC standards is shown. Refer to the shipping label for the actual reflow temperature that will be used to mount the part to the printed circuit board.

(6) **Part marking:** There may be an additional marking, which relates to the logo, the lot trace code information, or the environmental category of the part.

Multiple part markings will be inside parentheses. Only one part marking contained in parentheses and separated by a "~" will appear on a part. If a line is indented then it is a continuation of the previous line and the two combined represent the entire part marking for that device.

**Important Information and Disclaimer:** The information provided on this page represents TI's knowledge and belief as of the date that it is provided. TI bases its knowledge and belief on information provided by third parties, and makes no representation or warranty as to the accuracy of such information. Efforts are underway to better integrate information from third parties. TI has taken and continues to take reasonable steps to provide representative and accurate information but may not have conducted destructive testing or chemical analysis on incoming materials and chemicals. TI and TI suppliers consider certain information to be proprietary, and thus CAS numbers and other limited information may not be available for release.

In no event shall TI's liability arising out of such information exceed the total purchase price of the TI part(s) at issue in this document sold by TI to Customer on an annual basis.



**TAPE AND REEL INFORMATION**

**QUADRANT ASSIGNMENTS FOR PIN 1 ORIENTATION IN TAPE**

\*All dimensions are nominal

| Device          | Package Type | Package Drawing | Pins | SPQ  | Reel Diameter (mm) | Reel Width W1 (mm) | A0 (mm) | B0 (mm) | K0 (mm) | P1 (mm) | W (mm) | Pin1 Quadrant |
|-----------------|--------------|-----------------|------|------|--------------------|--------------------|---------|---------|---------|---------|--------|---------------|
| TPS542A50RJMR   | VQFN-HR      | RJM             | 33   | 3000 | 330.0              | 12.4               | 4.25    | 4.75    | 1.2     | 8.0     | 12.0   | Q3            |
| TPS542A50RJMRG4 | VQFN-HR      | RJM             | 33   | 3000 | 330.0              | 12.4               | 4.25    | 4.75    | 1.2     | 8.0     | 12.0   | Q3            |



**TAPE AND REEL BOX DIMENSIONS**

\*All dimensions are nominal

| Device          | Package Type | Package Drawing | Pins | SPQ  | Length (mm) | Width (mm) | Height (mm) |
|-----------------|--------------|-----------------|------|------|-------------|------------|-------------|
| TPS542A50RJMR   | VQFN-HR      | RJM             | 33   | 3000 | 367.0       | 367.0      | 38.0        |
| TPS542A50RJMRG4 | VQFN-HR      | RJM             | 33   | 3000 | 367.0       | 367.0      | 38.0        |

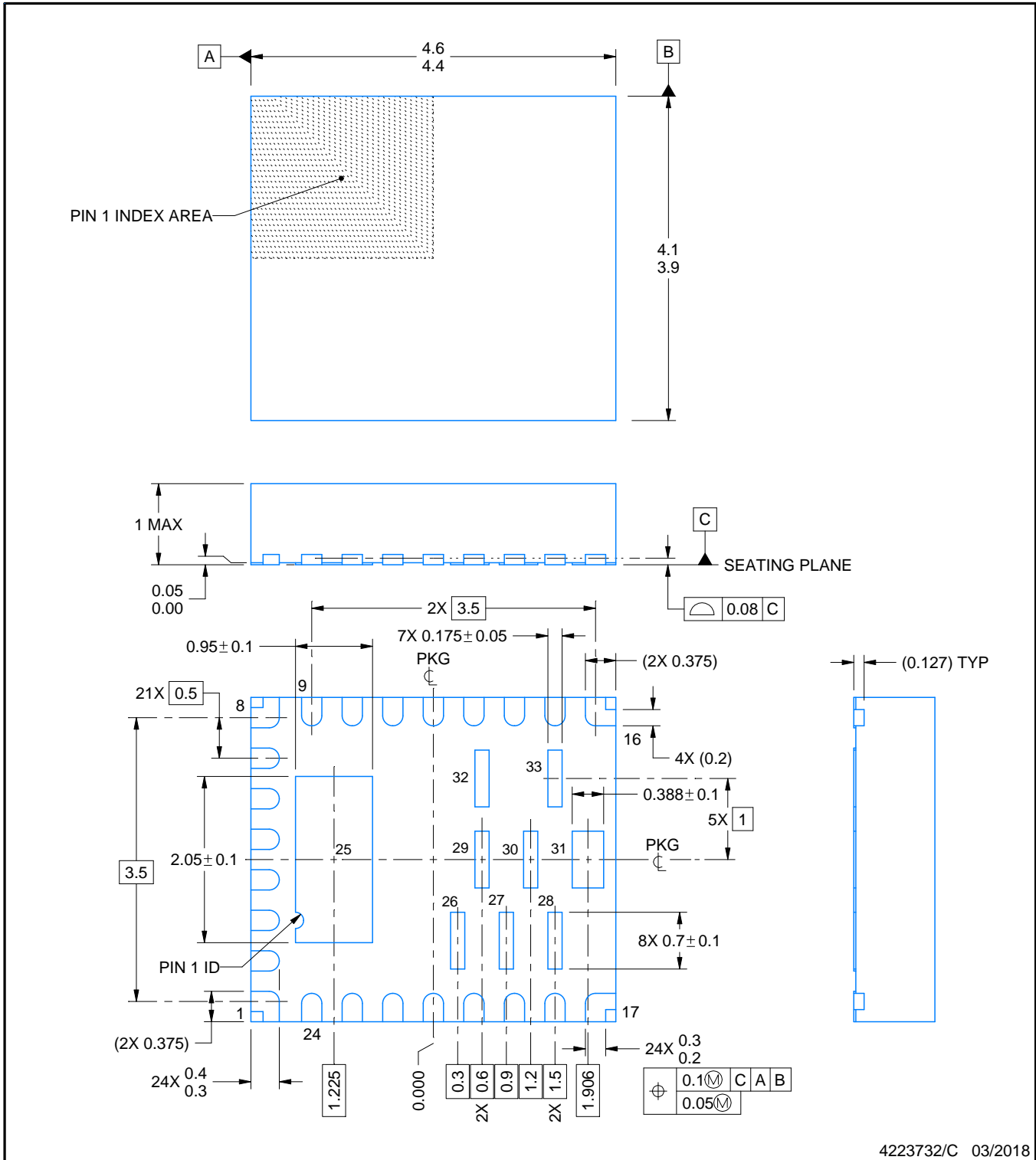

4223732/C 03/2018

NOTES:

1. All linear dimensions are in millimeters. Any dimensions in parenthesis are for reference only. Dimensioning and tolerancing per ASME Y14.5M.
2. This drawing is subject to change without notice.
3. The package thermal pad must be soldered to the printed circuit board for thermal and mechanical performance.

# EXAMPLE BOARD LAYOUT

RJM0033A

VQFN-HR - 1 mm max height

PLASTIC QUAD FLATPACK - NO LEAD

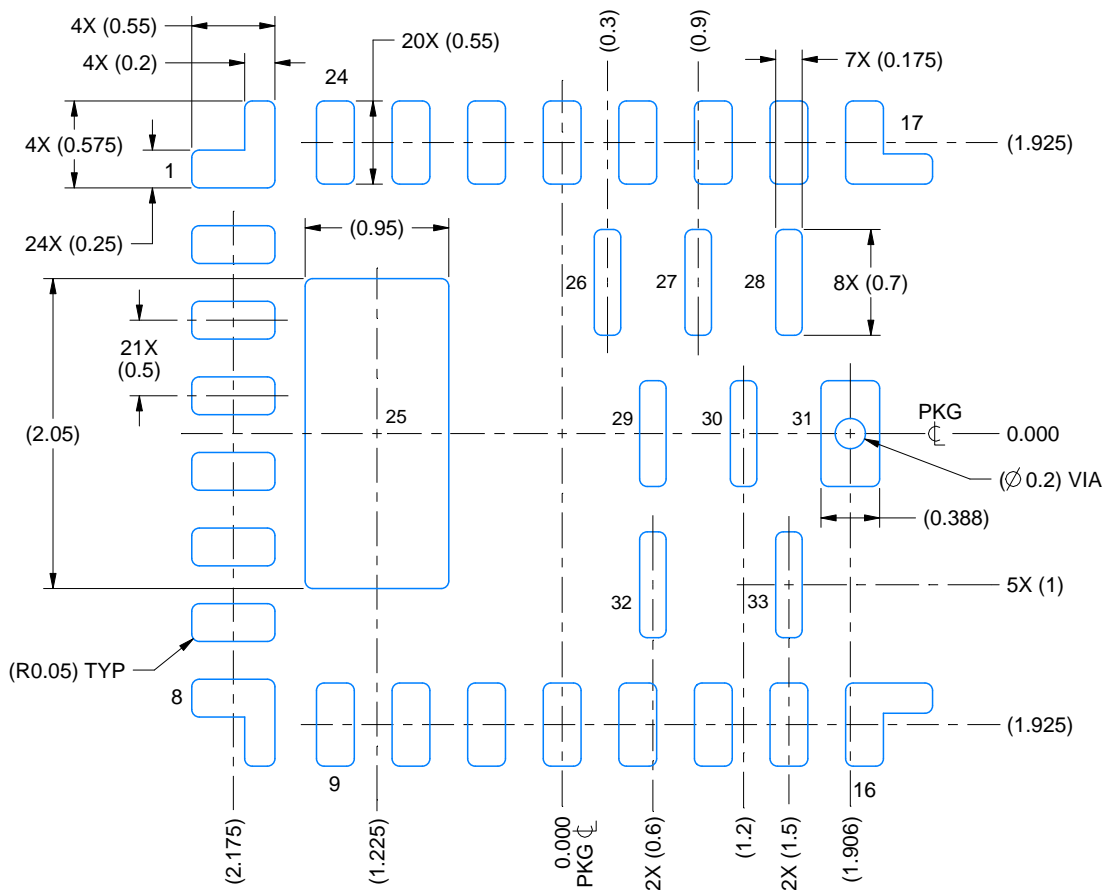

LAND PATTERN EXAMPLE  
EXPOSED METAL SHOWN  
SCALE:20X

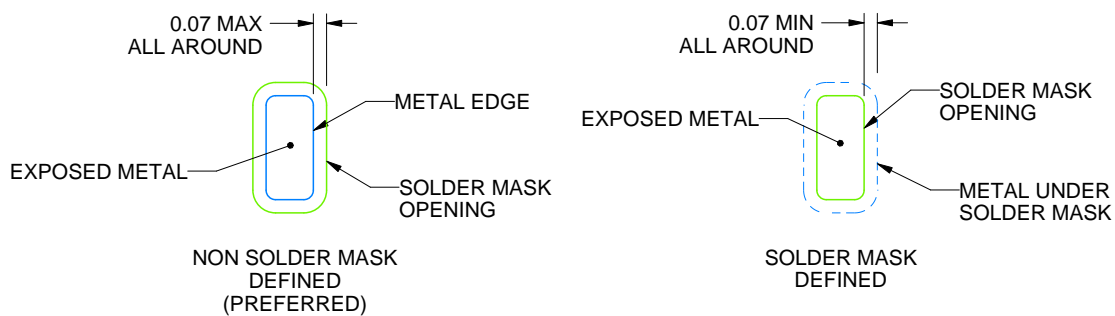

SOLDER MASK DETAILS

4223732/C 03/2018

NOTES: (continued)

- This package is designed to be soldered to a thermal pad on the board. For more information, see Texas Instruments literature number SLUA271 ([www.ti.com/lit/slua271](http://www.ti.com/lit/slua271)).
- Vias are optional depending on application, refer to device data sheet. If any vias are implemented, refer to their locations shown on this view. It is recommended that vias under paste be filled, plugged or tented.

# EXAMPLE STENCIL DESIGN

RJM0033A

VQFN-HR - 1 mm max height

PLASTIC QUAD FLATPACK - NO LEAD

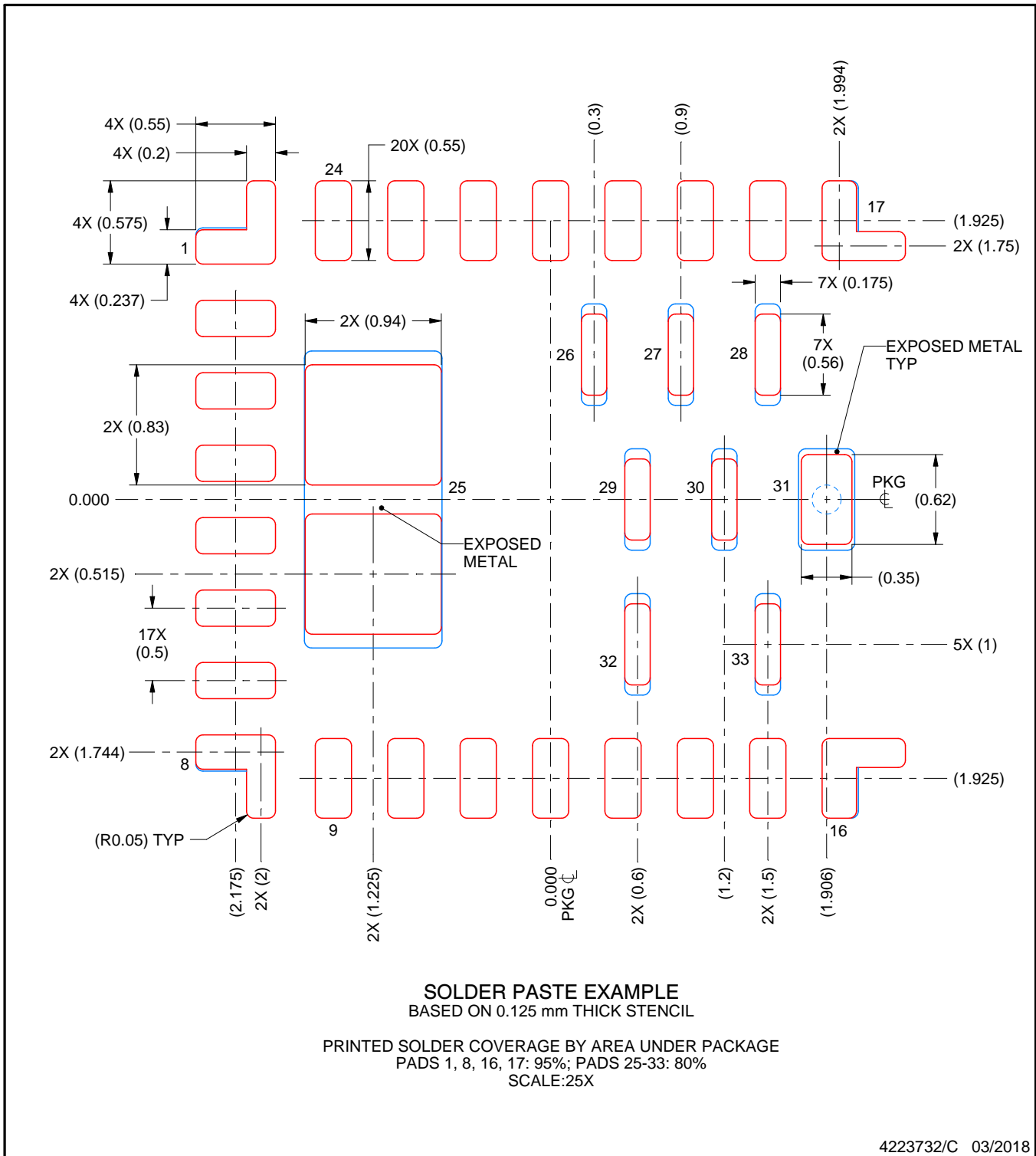

NOTES: (continued)

6. Laser cutting apertures with trapezoidal walls and rounded corners may offer better paste release. IPC-7525 may have alternate design recommendations.

## IMPORTANT NOTICE AND DISCLAIMER

TI PROVIDES TECHNICAL AND RELIABILITY DATA (INCLUDING DATASHEETS), DESIGN RESOURCES (INCLUDING REFERENCE DESIGNS), APPLICATION OR OTHER DESIGN ADVICE, WEB TOOLS, SAFETY INFORMATION, AND OTHER RESOURCES "AS IS" AND WITH ALL FAULTS, AND DISCLAIMS ALL WARRANTIES, EXPRESS AND IMPLIED, INCLUDING WITHOUT LIMITATION ANY IMPLIED WARRANTIES OF MERCHANTABILITY, FITNESS FOR A PARTICULAR PURPOSE OR NON-INFRINGEMENT OF THIRD PARTY INTELLECTUAL PROPERTY RIGHTS.

These resources are intended for skilled developers designing with TI products. You are solely responsible for (1) selecting the appropriate TI products for your application, (2) designing, validating and testing your application, and (3) ensuring your application meets applicable standards, and any other safety, security, regulatory or other requirements.

These resources are subject to change without notice. TI grants you permission to use these resources only for development of an application that uses the TI products described in the resource. Other reproduction and display of these resources is prohibited. No license is granted to any other TI intellectual property right or to any third party intellectual property right. TI disclaims responsibility for, and you fully indemnify TI and its representatives against any claims, damages, costs, losses, and liabilities arising out of your use of these resources.

TI's products are provided subject to [TI's Terms of Sale](#), [TI's General Quality Guidelines](#), or other applicable terms available either on [ti.com](http://ti.com) or provided in conjunction with such TI products. TI's provision of these resources does not expand or otherwise alter TI's applicable warranties or warranty disclaimers for TI products. Unless TI explicitly designates a product as custom or customer-specified, TI products are standard, catalog, general purpose devices.

TI objects to and rejects any additional or different terms you may propose.

Copyright © 2025, Texas Instruments Incorporated

Last updated 10/2025