

# TPS61390 85-V<sub>OUT</sub> Boost Converter With Current Mirror and Sample / Hold

## 1 Features

- Input voltage range: 2.5 V to 5.5 V
- Output voltage range: up to 85 V
- $R_{(DS)on}$  of switching FET: 0.9  $\Omega$
- Switch current limit: 1000 mA
- Sample window with minimum 400-ns
- High optical power protection with 0.5- $\mu$ s response time
- Switching frequency: 700 kHz
- Quiescent current: 110  $\mu$ A from VIN, 340  $\mu$ A from VOUT, 140  $\mu$ A from AVCC
- Soft-start time: 4.8 ms
- Package: 3 mm  $\times$  3 mm  $\times$  0.75 mm QFN

## 2 Applications

- APD bias
- Optical line terminal
- High-voltage sensor supply

## 3 Description

The TPS61390 is a 700-kHz pulse-width modulating (PWM) step-up converter with an 85-V switch FET with an input ranging from 2.5 V to 5.5 V. The switching peak current is up to 1000 mA. The TPS61390 includes accurate current mirror with two gain options selectable (1 : 5 or 4 : 5).

Additionally, the TPS61390 integrates a sample-and-hold circuitry for the burst-mode optical receiver applications to capture the current flowing through the APD and pass the current to an external ADC. The device supports fast response time during the transition between strong and weak optical density. The TPS61390 also provides high optical-power protection with an additional FET in series with the APD power path with the typical response time of 0.5  $\mu$ s. It can recover automatically once the high optical releasing.

The TPS61390 is available in 3 mm  $\times$  3 mm QFN package with exposed pad underneath.

### Device Information<sup>(1)</sup>

PART NUMBER	PACKAGE	BODY SIZE (NOM)
TPS61390	WQFN (16)	3.00 mm $\times$ 3.00 mm

(1) For all available packages, see the orderable addendum at the end of the data sheet.

### Typical Application Circuit

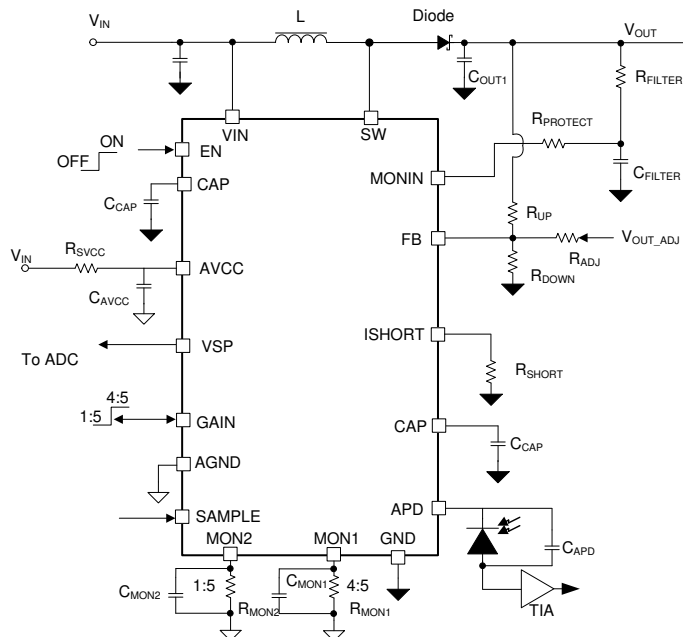

## Table of Contents

<b>1 Features</b> .....	<b>1</b>	7.4 Device Functional Mode .....	<b>12</b>
<b>2 Applications</b> .....	<b>1</b>	<b>8 Application and Implementation</b> .....	<b>13</b>
<b>3 Description</b> .....	<b>1</b>	8.1 Application Information.....	<b>13</b>
<b>4 Revision History</b> .....	<b>2</b>	8.2 Typical Application .....	<b>13</b>
<b>5 Pin Configuration and Functions</b> .....	<b>3</b>	<b>9 Power Supply Recommendations</b> .....	<b>17</b>
<b>6 Specifications</b> .....	<b>4</b>	<b>10 Layout</b> .....	<b>18</b>
6.1 Recommended Operating Conditions .....	4	10.1 Layout Guidelines .....	18
6.2 Absolute Maximum Ratings .....	4	10.2 Layout Example .....	18
6.3 ESD Ratings.....	4	<b>11 Device and Documentation Support</b> .....	<b>19</b>
6.4 Thermal Information .....	4	11.1 Receiving Notification of Documentation Updates .....	19
6.5 Electrical Characteristics.....	5	11.2 Community Resources.....	19
6.6 Typical Characteristics .....	7	11.3 Trademarks .....	19
<b>7 Detailed Description</b> .....	<b>9</b>	11.4 Electrostatic Discharge Caution.....	19
7.1 Overview .....	9	11.5 Glossary .....	19
7.2 Functional Block Diagram .....	10	<b>12 Mechanical, Packaging, and Orderable Information</b> .....	<b>19</b>
7.3 Feature Description.....	10		

## 4 Revision History

NOTE: Page numbers for previous revisions may differ from page numbers in the current version.

<b>Changes from Revision A (June 2019) to Revision B</b>	<b>Page</b>
<ul style="list-style-type: none"> <li>Changed text string in <a href="#">Current Mirror</a> section from "The voltage of MON1 is up to 400 mV....." to "The maximum voltage of MON1 and MON2 is 2.5 V." .....</li> </ul>	<b>11</b>

<b>Changes from Original (April 2019) to Revision A</b>	<b>Page</b>
<ul style="list-style-type: none"> <li>Changed status to Production Data .....</li> </ul>	<b>1</b>

## 5 Pin Configuration and Functions

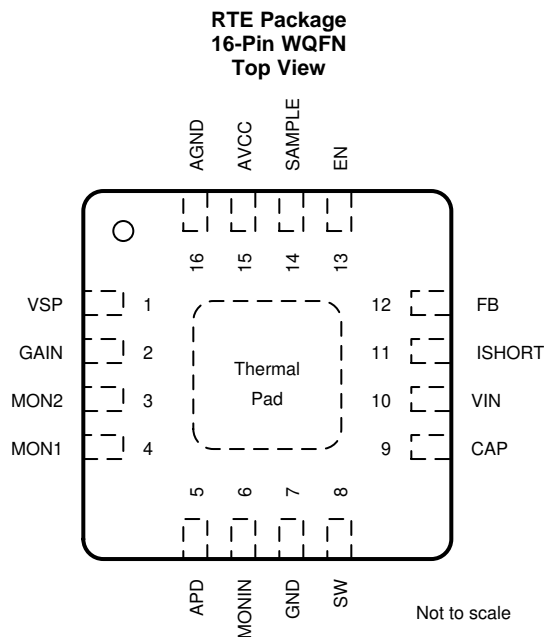

### Pin Functions

PIN		I/O	DESCRIPTION
NAME	NO.		
VSP	1	O	Sample/Hold voltage output with single-ended output.
GAIN	2	I	GAIN of the current mirror selection indicator of the sample/hold output:
			Output low: sample/hold for current mirror gain 4 : 5;
			Output high: sample/hold for current mirror gain 1 : 5;
			This pin can also be any input pin:
			Input low: sample/hold for current mirror gain 4 : 5;
			Input high: sample/hold for current mirror gain 1 : 5
MON2	3	O	Current mirror output pin of 1 : 5 ratio (Mirror current: APD current)
MON1	4	O	Current mirror output pin of 4 : 5 ratio (Mirror current: APD current)
APD	5	O	Power supply for the APD, connect this pin with the cathode of APD
MONIN	6	I	Current mirror input pin
GND	7	–	Power Ground
SW	8	PWR	The switching node pin of the converter. It is connected to the drain of the internal low-side power MOSFET and the source of the internal high-side power MOSFET
CAP	9	O	Connecting a capacitor externally to lower the noise for current mirror.
VIN	10	I	IC power supply input
ISHORT	11	O	Programming the current limit for high optical power protection by a resistor between this pin and GND.
FB	12	I	Feedback voltage
EN	13	I	Enable logic input. Logic high level enables the device. Logic low level disables the device and turns it into shutdown mode
SAMPLE	14	I	The sample trigger pin, the rising edge of this pin to trigger the sample and falling edge to hold the sampled voltage.
AVCC	15	I	Power supply for the sample/hold circuitry
AGND	16	–	Analog ground for the sample / hold and current mirror circuitry
Exposed Thermal Pad			Connect with GND, TI recommends connecting to Power GND on PCB

## 6 Specifications

### 6.1 Recommended Operating Conditions

over operating free-air temperature range (unless otherwise noted)

		MIN	NOM	MAX	UNIT
V <sub>IN</sub>	Input voltage	2.5		5.5	V
V <sub>OUT</sub>	Output voltage	20		85	V
T <sub>J</sub>	Junction temperature	–40		125	°C
L	Effective Inductance		4.7		μH
C <sub>IN</sub>	Effective Input Capacitance		1		μF
C <sub>OUT</sub>	Effective Output Capacitance		0.1		μF

### 6.2 Absolute Maximum Ratings

over operating free-air temperature range (unless otherwise noted)<sup>(1)</sup>

		MIN	MAX	UNIT
Voltage	SW, APD, MONIN,CAP	–0.3	85	V
	Other pins	–0.3	6	V
T <sub>J</sub>	Operating junction temperature	–40	125	°C
T <sub>stg</sub>	Storage temperature	–65	150	°C

- (1) Stresses beyond those listed under *Absolute Maximum Rating* may cause permanent damage to the device. These are stress ratings only, which do not imply functional operation of the device at these or any other conditions beyond those indicated under *Recommended Operating Condition*. Exposure to absolute-maximum-rated conditions for extended periods may affect device reliability.

### 6.3 ESD Ratings

			VALUE	UNIT
V <sub>(ESD)</sub>	Electrostatic discharge	Human body model (HBM), per ANSI/ESDA/JEDEC JS-001, allpins <sup>(1)</sup>	±1500	V
		Charged device model (CDM), per JEDEC specification JESD22-C101, all pins <sup>(2)</sup>	±500	

- (1) JEDEC document JEP155 states that 500-V HBM allows safe manufacturing with a standard ESD control process.  
 (2) JEDEC document JEP157 states that 250-V CDM allows safe manufacturing with a standard ESD control process.

### 6.4 Thermal Information

THERMAL METRIC <sup>(1)</sup>		TPS61390	UNIT
		RTE (WQFN)	
		16 PINS	
R <sub>θJA</sub>	Junction-to-ambient thermal resistance	52.9	°C/W
R <sub>θJC(top)</sub>	Junction-to-case (top) thermal resistance	54.4	°C/W
R <sub>θJB</sub>	Junction-to-board thermal resistance	27.9	°C/W
Ψ <sub>JT</sub>	Junction-to-top characterization parameter	2.0	°C/W
Y <sub>JB</sub>	Junction-to-board characterization parameter	27.8	°C/W
R <sub>θJC(bot)</sub>	Junction-to-case (bottom) thermal resistance	12.8	°C/W

- (1) For more information about traditional and new thermal metrics, see the [Semiconductor and IC Package Thermal Metrics](#) application report.

## 6.5 Electrical Characteristics

Over recommended free-air temperature range,  $V_{IN} = 3.3\text{ V}$ ,  $AV_{CC} = 3.3\text{ V}$ ,  $V_{MONIN} = 20\text{ V}$  to  $85\text{ V}$ ,  $T_J = -40^\circ\text{C}$  to  $125^\circ\text{C}$ , typical values are at  $T_A = 25^\circ\text{C}$  (unless otherwise noted)

PARAMETER		TEST CONDITIONS	MIN	TYP	MAX	UNIT
<b>POWER SUPPLY</b>						
$V_{IN}$	Input voltage range		2.5		5.5	V
$V_{UVLO}$	Under voltage lock out	$V_{IN}$ falling		2.4	2.5	V
	Under voltage lock out hysteresis	$V_{UVLO}$ rising - $V_{UVLO}$ falling		200		mV
$I_{Q\_IN}$	Quiescent current into VIN pin	$V_{IN} = 3.3\text{ V}$ , $V_{FB} = V_{REF} + 0.1\text{ V}$ , No switching, $-40^\circ\text{C} \leq T_J \leq 85^\circ\text{C}$		110	140	$\mu\text{A}$
$I_{Q\_OUT}$	Quiescent current into VOUT pin	$V_{IN} = 3.3\text{ V}$ , $V_{FB} = V_{REF} + 0.1\text{ V}$ , No switching, $-40^\circ\text{C} \leq T_J \leq 85^\circ\text{C}$		340	430	$\mu\text{A}$
$I_{Q\_VCC}$	Quiescent current into AVCC pin	$AV_{CC} = 3.3\text{ V}$ $-40^\circ\text{C} \leq T_J \leq 85^\circ\text{C}$		140	180	$\mu\text{A}$
$I_{SD}$	Shutdown current into VIN pin	$2.5\text{ V} \leq V_{IN} \leq 5.5\text{ V}$ , $EN = 0$ , $-40^\circ\text{C} \leq T_J \leq 85^\circ\text{C}$			1	$\mu\text{A}$
	Shutdown current into VOUT pin	$EN = 0$ , $-40^\circ\text{C} \leq T_J \leq 85^\circ\text{C}$			1	$\mu\text{A}$
	Shutdown current into AVCC pin	$AV_{CC} = 3.3\text{ V}$ , $EN = 0$ , $-40^\circ\text{C} \leq T_J \leq 85^\circ\text{C}$			1	$\mu\text{A}$
<b>OUTPUT</b>						
$V_{OUT}$	Output voltage range				85	V
$V_{REF}$	Feedback regulation reference voltage	$V_{IN} = 2.5\text{ V}$ to $5.5\text{ V}$ , $T_J = 25^\circ\text{C}$	1.188	1.2	1.212	V
		$V_{IN} = 2.5\text{ V}$ to $5.5\text{ V}$ , $-40^\circ\text{C} \leq T_J \leq 125^\circ\text{C}$	1.182	1.2	1.218	V
$I_{FB}$	Feedback input leakage current			1	25	nA
<b>POWER SWITCH</b>						
$R_{DS(on)}$	Low-side FET on resistance	$3\text{ V} \leq V_{IN} \leq 5.5\text{ V}$		900	1300	m $\Omega$
<b>SWITCHING CHARACTERISTIC</b>						
$f_{SW}$	Switching frequency	$V_{IN} = 3.3\text{ V}$ , $V_{OUT} = 60\text{ V}$	600	700	800	kHz
<b>CURRENT MIRROR</b>						
$k_{MON1}$	4:5 Current mirror gain	$I_{APD} = 5\text{ }\mu\text{A}$ to $200\text{ }\mu\text{A}$	0.76	0.8	0.84	
$k_{MON2}$	1:5 Current mirror gain	$I_{APD} = 100\text{ }\mu\text{A}$ to $2\text{ mA}$	0.19	0.2	0.21	
$V_{MON}$	MON1 / MON2 Threshold		380	400	420	mV
$V_{APD\_DRP}$	Current mirror voltage drop	$I_{APD} = 1\text{ mA}$	2.2	2.5	2.8	V
		$I_{APD} = 5\text{ }\mu\text{A}$		2.45		V
$I_{BIAS}$	Current mirror bias current		15	20	25	$\mu\text{A}$
<b>SAMPLE / HOLD</b>						
$V_{ERROR}$	Sample/hold output error steady, +/-6 sigma	$I_{APD} = 20\text{ }\mu\text{A}$ , $GAIN = 0.8$ , $R_{MON} = 3\text{ k}\Omega$	-15		+15	%
$V_{ERROR}$	Sample/hold output error steady, +/-6 sigma	$I_{APD} = 500\text{ }\mu\text{A}$ , $GAIN = 0.2$ , $R_{MON} = 3\text{ k}\Omega$	-5		+5	%
$t_{SP\_DEL}$	Amplifier settling down time				10	$\mu\text{s}$
$t_{GAIN\_COMP}$	Gain selection comparator time	+/-20% gap of threshold			8	$\mu\text{s}$
$V_{DROP\_SP}$	Drop voltage during sample/hold	Sample voltage sensing value variation at 10-100 $\mu\text{s}$ , (Max-Min)/Average			1	%
<b>CURRENT LIMIT</b>						
$I_{LIM\_SW}$	Peak switching current limit	$V_{IN} = 3.3\text{ V}$ , $V_{OUT} = 60\text{ V}$	800	1000	1200	mA
$I_{SHORT}$	High optical power current limit	$R_{ISHORT} = 25\text{ k}\Omega$	3.7	4	4.3	mA
		$R_{ISHORT} = 50\text{ k}\Omega$	1.8	2	2.2	mA

## Electrical Characteristics (continued)

Over recommended free-air temperature range,  $V_{IN} = 3.3\text{ V}$ ,  $AV_{CC} = 3.3\text{ V}$ ,  $V_{MONIN} = 20\text{ V}$  to  $85\text{ V}$ ,  $T_J = -40^\circ\text{C}$  to  $125^\circ\text{C}$ , typical values are at  $T_A = 25^\circ\text{C}$  (unless otherwise noted)

PARAMETER		TEST CONDITIONS	MIN	TYP	MAX	UNIT
<b>CONTROL (EN, SAMPLE, GAIN)</b>						
$V_{EN\_H}$	EN Logic high threshold				1.2	V
$V_{EN\_L}$	EN Logic low threshold		0.4			V
$R_{EN}$	EN pull down resistor			800		k $\Omega$
$V_{SAMPLE\_H}$	Sample Logic high threshold				0.7 x AVCC	V
$V_{SAMPLE\_L}$	Sample Logic low threshold		0.3 x AVCC			V
$V_{GAIN\_H}$	Gain Logic high threshold				0.7 x AVCC	V
$V_{GAIN\_L}$	Gain Logic low threshold		0.3 x AVCC			V
$R_{GAIN\_OUT}$	Output resistor			5.5		k $\Omega$
<b>TIMING</b>						
$t_{SS}$	Soft start time	Ref voltage 0 to 1.2V		4.8		ms
$t_{DELAY}$	Delay time for high optical power protection	$I_{APD} = 5\text{ mA}$ , $I_{SHORT} = 3\text{ mA}$		0.5		$\mu\text{s}$
<b>THERMAL PROTECTION</b>						
$T_{SD}$	Thermal shutdown threshold	$T_J$ rising		150		$^\circ\text{C}$
$T_{SD\_HYS}$	Thermal shutdown hysteresis	$T_J$ falling below $T_{SD}$		20		$^\circ\text{C}$

## 6.6 Typical Characteristics

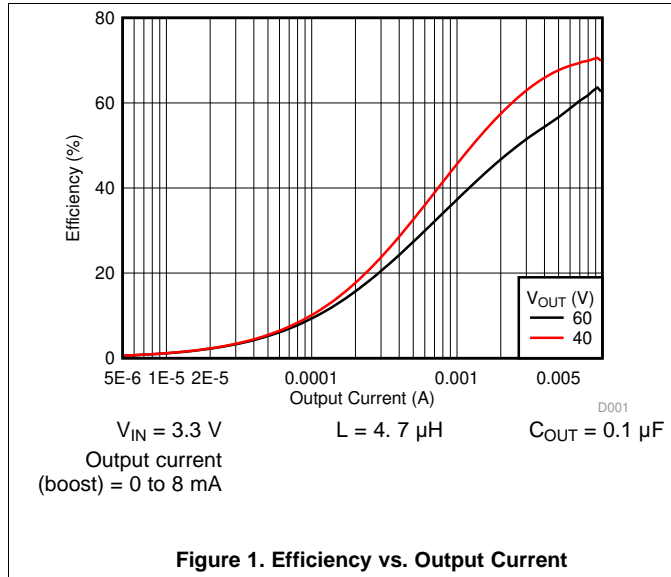

Figure 1. Efficiency vs. Output Current

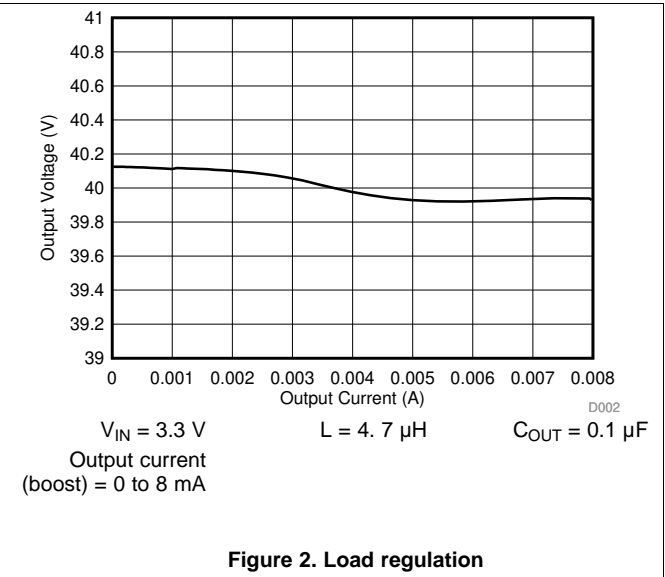

Figure 2. Load regulation

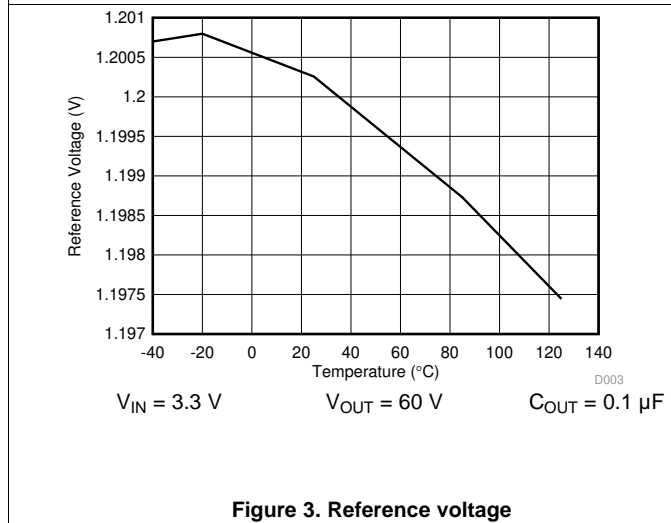

Figure 3. Reference voltage

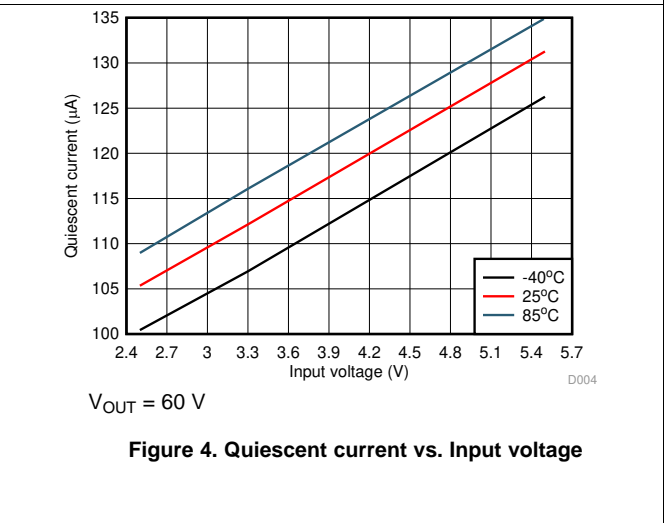

Figure 4. Quiescent current vs. Input voltage

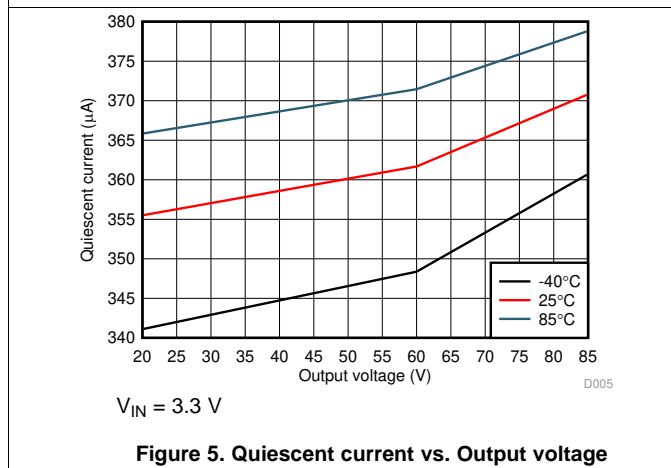

Figure 5. Quiescent current vs. Output voltage

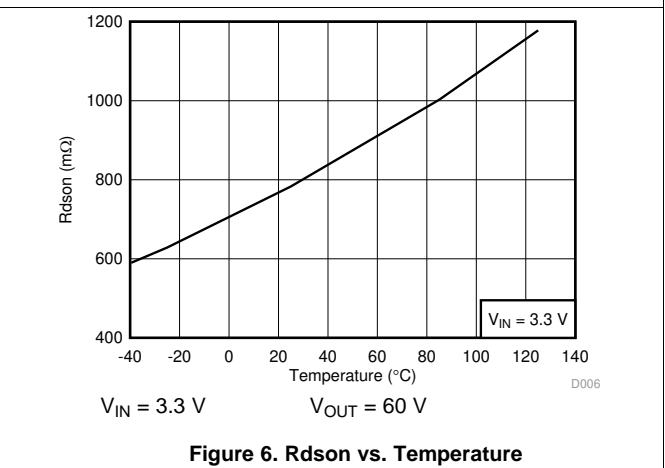
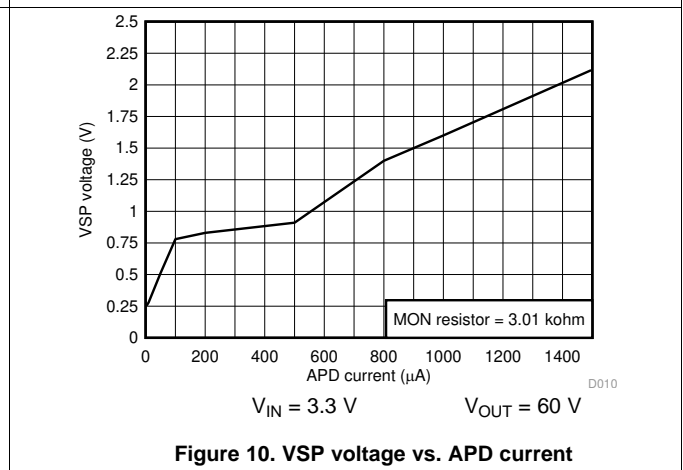
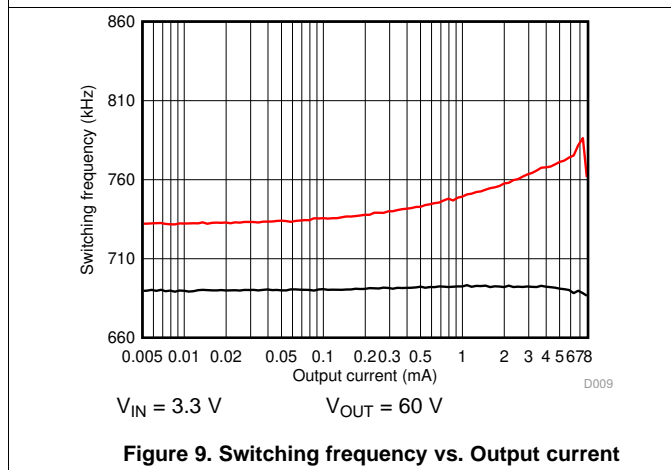
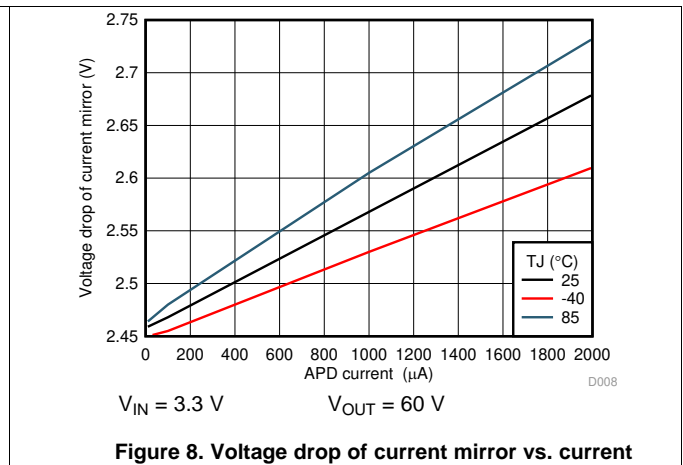
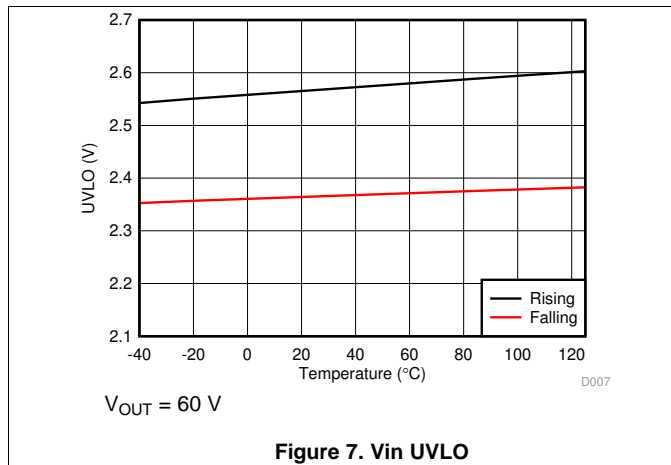

Figure 6.  $R_{ds(on)}$  vs. Temperature

Typical Characteristics (continued)



## 7 Detailed Description

### 7.1 Overview

The TPS61390 is a fully integrated boost converter with an 85-V FET to convert a low input voltage to a higher voltage for biasing the APD. The TPS61390 supports an input voltage ranging from 2.5 V to 5.5 V. The device operates at a 700 kHz pulse-width modulation (PWM) crossing the whole load range.

The device can accurately mirror the APD current ranging from 0.5  $\mu$ A to 2 mA. There are two ratio options for the current proportional to APD current: the MON1 (4 : 5) and MON2 (1 : 5). By connecting a resistor from the mirror output (MON1 or MON2) to GND, the current flowing through the APD is converted into the voltage crossing the resistor from MON1 / MON2 to GND.

With the sample / hold circuitry built-in and triggered by an external sampling clock, the current mirror signal (voltage) is transferred and stored on the holdup capacitor, the voltage on the holdup capacitor is then passed over to the output of an operational amplifier. An external ADC can sense the voltage of the output of the operational amplifier to measure the optical intensity.

Additionally, a high power optical protection is integrated by clamping the pre-set current limit (program by the  $I_{\text{SHORT}}$  resistor). The response time of the high optical power is typically 0.5  $\mu$ s. The device could recovery automatically when the high optical power is removed.

The device comes in a 3-mm  $\times$  3-mm QFN package with the operating junction temperature covering from  $-40^{\circ}\text{C}$  to  $125^{\circ}\text{C}$ .

## 7.2 Functional Block Diagram

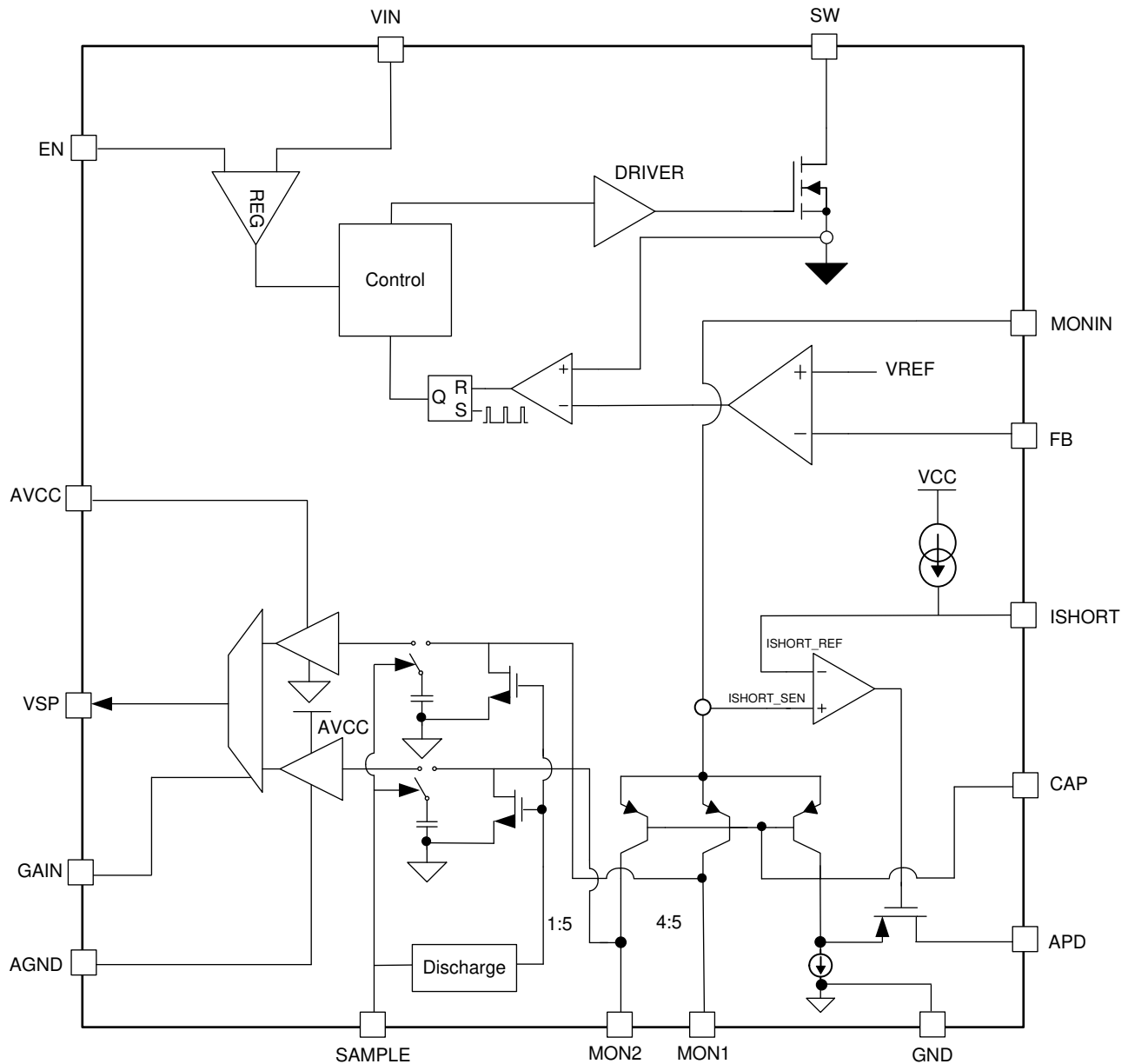

## 7.3 Feature Description

### 7.3.1 Undervoltage Lockout

An undervoltage lockout (UVLO) circuit stops the operation of the converter when the input voltage drops below the typical UVLO threshold of 2.5 V. A hysteresis of 200 mV is added so that the device cannot be enabled again until the input voltage goes up to 200 mV.

### 7.3.2 Enable and Disable

When the input voltage is above maximal UVLO rising threshold of 2.5 V and the EN pin is pulled above the high threshold (1.2 V min.), the TPS61390 is enabled. When the EN pin is pulled below the low threshold (0.4 maximum), the device goes into shutdown mode.

## Feature Description (continued)

### 7.3.3 Current Mirror

There are two current mirror options for TPS61390: the gain of 4: 5 (MON1) and 1: 5 (MON2). The maximum voltage of MON1 and MON2 is 2.5 V.

### 7.3.4 Sample and Hold

The TPS61390 has the sample-and-hold circuitry built in, including a holdup capacitor for storing the voltage capture, a FET switch, and one operational amplifier, illustrated in [Functional Block Diagram](#).

To sample the current mirror signal, the switch connects the capacitor to the input of the common-mode operational amplifier. The amplifier converts the voltage of the capacitor to the output terminal with 4:1 ratio.

In hold mode the switch disconnects the hold-up capacitor from the operation amplifier, the voltage of the capacitor is discharged to 0 before connecting with current mirror output terminal (MON1 and MON2).

These are two ratios of the current mirror that can be selected automatically by comparing the MON1 voltage with the internal 400-mV reference. The voltage of MON1 is sampled if the MON1 voltage is below 400 mV, while the voltage of MON2 is sampled if MON1 being larger than 400 mV. The GAIN pin reports which ratio is selected for the sample and hold, the logic low (0) for MON1 while logic high (AVCC) for MON2 selected.

Also, the GAIN can be externally selected, pulling low to select the 1 : 5 while high for 4 : 5 ratio.

The voltage measured on VSP pin is calculated by [Equation 1](#) and [Equation 2](#) :

$$VSP = 4 \times (0.8 \times I_{APD} \times R_{MON1}) + 4 \times (I_{BIAS} \times R_{MON1})$$

where

- VSP is the voltage sampled on VSP pin
  - $I_{APD}$  is the current flowing through the APD pin.
  - $R_{MON1}$  is the resistor connecting with MON1 pin
  - $I_{BIAS}$  is the bias current of current mirror
- (1)

$$VSP = 4 \times (0.2 \times I_{APD} \times R_{MON2}) + 4 \times (I_{BIAS} \times R_{MON2})$$

where

- $R_{MON2}$  is the resistor connecting with MON2 pin
- (2)

The bias current is around 20  $\mu$ A (typical) when there is no APD current flowing through. The bias voltage of MON1 or MON2 is 60 mV given a 3-k $\Omega$  MON resistor connected with MON1 or MON2. Also, the VSP voltage is reset to 250 mV prior to every sample clock coming. The maximum voltage of the MON1 is clamped to 400 mV while maximum of MON2 is 2.5 V. The maximum voltage of VSP is close to the  $A_{VCC}$  (0.1 V lower typically), which is the supply voltage of the sample and hold circuitry.

As the timing diagram shown in [Figure 11](#), the sample and hold is enabled by the rising edge of an external clock connecting to the SAMPLE pin, the holdup capacitor captures the voltage of current mirror signal (the voltage of MON1 and MON2).

At the falling edge, the sampling is stopped, and the voltage stored on the holdup capacitor is transferred to the output of the operational amplifier. The minimum time of the sampling time the TPS61390 supports is 350 ns (typically). The voltage on the stored capacitor is switched to the amplifier's input voltage. There is approximately 10- $\mu$ s delay time to make the output voltage of the amplifier ready.

The GAIN selector is always active and the GAIN value is captured by the falling edge of the sample signal.

## Feature Description (continued)

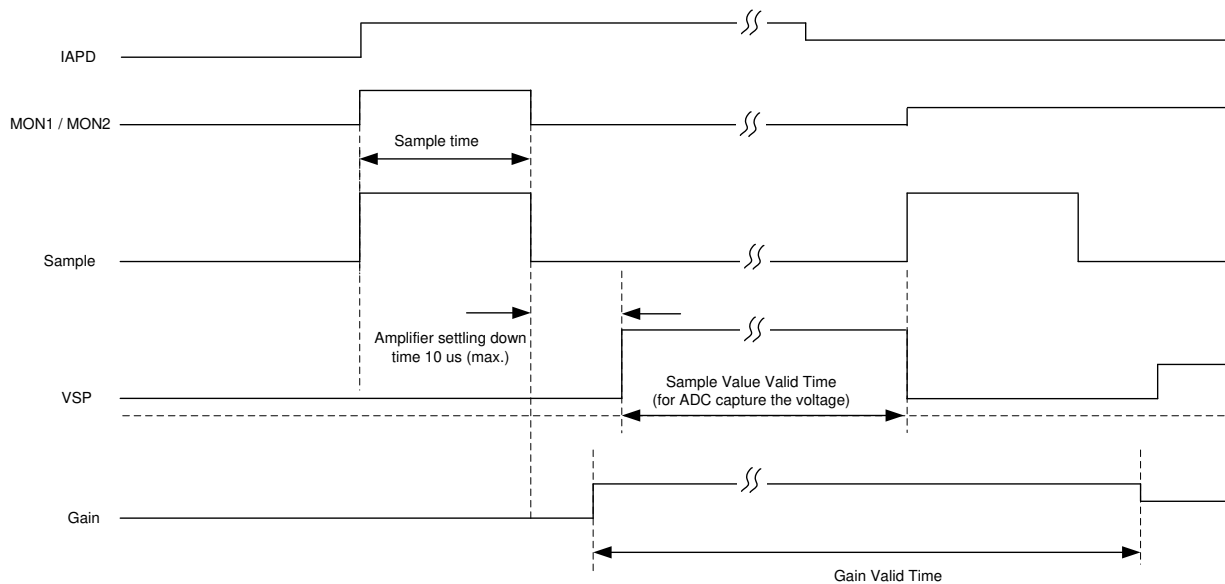

**Figure 11. TPS61390 Sample / Hold Circuit Timing**

The output settling time of the operational amplifier is 10  $\mu\text{s}$  while the maximum duration time is 100  $\mu\text{s}$  with 1% derating (with the nominal voltage).

### 7.3.5 High Optical Power Protection

There is an additional FET in series of power path connecting with the APD. When the current flowing through the APD exceeds the short protection threshold (set by connecting the resistor from  $I_{\text{SHORT}}$  to GND), the on resistance of the FET becomes larger to clamp the current within the protection threshold by lowering the APD bias voltage. It takes typically 0.5  $\mu\text{s}$  for the FET to respond in case of high optical power occurring.

When the high optical power condition releases, the TPS61390 recovers automatically back to the normal operation mode.

## 7.4 Device Functional Mode

### 7.4.1 PFM Operation

The TPS61390 integrates a power save mode with pulse frequency modulation (PFM) at the light load. When a light load condition occurs, the COMP pin voltage naturally decreases and reduces the peak current. When the COMP pin voltage further goes down with the load lowered and reaches the pre-set low threshold, the output of the error amplifier is clamped at this threshold and does not go down any more. If the load is further lowered, the device skips the switching cycles and reduces the switching losses and improves efficiency at the light load condition by reducing the average switching frequency.

## 8 Application and Implementation

### NOTE

Information in the following applications sections is not part of the TI component specification, and TI does not warrant its accuracy or completeness. TI's customers are responsible for determining suitability of components for their purposes. Customers should validate and test their design implementation to confirm system functionality.

### 8.1 Application Information

The TPS61390 is a step-up DC/DC converter with current monitor and sample / hold circuitry integrated. The following design procedure can be used to select component values for the TPS61390. This section presents a simplified discussion of the design process.

### 8.2 Typical Application

This application is designed for 2.5-V to 5.5-V input, and 60-V output user case

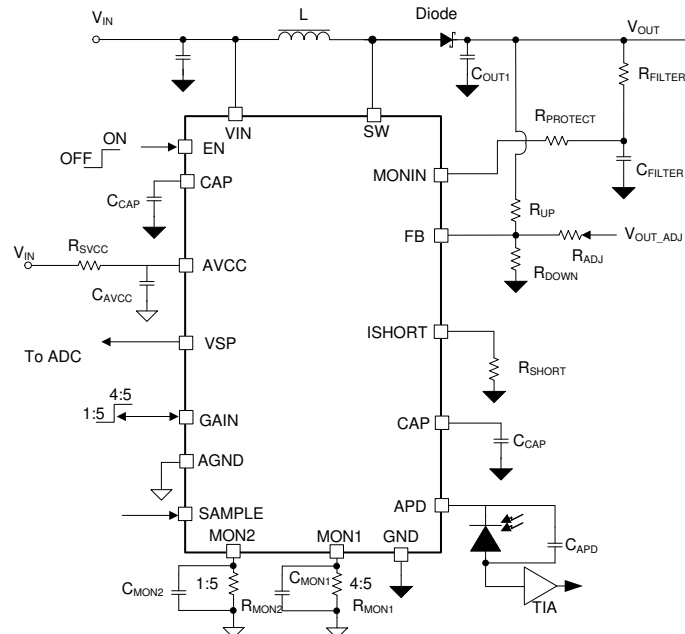

Figure 12. TPS61390 Typical Application

#### 8.2.1 Design Requirement

For this design example, use [Table 1](#) as the design parameters.

Table 1. Design Parameters

PARAMETER	VALUE
Input voltage range	2.5 V to 5.5 V
Output voltage	60 V
Operating frequency	700 kHz
APD Current	0 to 2 mA

## 8.2.2 Detailed Design Procedure

### 8.2.2.1 Selecting the Rectifier Diode

A Schottky diode is the preferred type for the rectifier diode due to its low forward voltage drop and small reverse recovery charge. Low reverse leakage current is important parameter when selecting the Schottky diode. The diode must be rated to handle the maximum output voltage plus the switching node ringing. Also, it must be able to handle the average output current.

### 8.2.2.2 Selecting the Inductor

It is suggested that the TPS61390 device works in the DCM operation; otherwise the output voltage would not be delivered for low input voltage to high output voltage.

With the device working in DCM operation, the maximum inductor could be calculated by equation [Equation 3](#) and [Equation 4](#):

$$L_{MAX} = \frac{V_{IN} \times D}{f_{SW} \times I_{LIM}}$$

where

- $V_{IN}$  is input voltage
- $D$  is duty cycle
- $f_{SW}$  is switching frequency
- $I_{LIM}$  is current limit

(3)

For instance, if  $V_{IN} = 3.3\text{ V}$ ,  $V_{OUT} = 60\text{ V}$ ,  $f_{SW} = 600\text{ kHz}$ ,  $I_{LIM} = 0.8\text{ A}$ , the  $L_{MAX} = 6.5\text{ }\mu\text{H}$

However, there is minimum inductance is determined by the power delivered to the output side at given input condition.

$$L_{MIN} = 2 \times \frac{V_{OUT} \times I_{OUT}}{\text{eff} \times f_{SW} \times I_{LIM}^2}$$

where

- $V_{OUT}$  is output voltage
- $I_{OUT}$  is output current
- $\text{eff}$  is the efficiency
- $f_{SW}$  is switching frequency
- $I_{LIM}$  is current limit

(4)

For instance, if  $I_{OUT} = 8\text{ mA}$ ,  $V_{OUT} = 60\text{ V}$ ,  $f_{SW} = 600\text{ kHz}$ ,  $I_{LIM} = 0.8\text{ A}$ ,  $\text{eff} = 0.6$ , the  $L_{MIN} = 4.2\text{ }\mu\text{H}$

With the calculation aforementioned, the operating inductor is recommended between the  $L_{MIN}$  and  $L_{MAX}$ .

The  $4.7\text{ }\mu\text{H}$  inductance is optimum value for using the TPS61390 in application.

### 8.2.2.3 Selecting Output Capacitor

Use low ESR capacitors at the output to minimize output voltage ripple. Use only X5R and X7R types, which retain their capacitance over wider voltage and temperature ranges than other types. Typically use a  $0.1\text{-}\mu\text{F}$  to  $1\text{-}\mu\text{F}$  capacitor for output voltage. Take care when evaluating the derating of a ceramic capacitor under the DC bias. Ceramic capacitors can derate its capacitance at its rated voltage. Therefore, consider enough margins on the voltage rating to ensure adequate capacitance at the required output voltage.

### 8.2.2.4 Selecting Filter Resistor and Capacitor

TI recommends an additional R-C filter be added for low ripple applications. The filter parameters is characterized based on the ripple requirement. Typically, use a  $100\text{-}\Omega$  and  $0.1\text{-}\mu\text{F}$  filter to reduce the switching output ripple.

### 8.2.2.5 Setting the Output Voltage

The output voltage of the TPS61390 is externally adjustable using a resistor divider network. The relationship between the output voltage and the resistor divider is given by [Equation 5](#).

$$V_{OUT} = V_{FB} \times \left(1 + \frac{R_{UP}}{R_{DOWN}}\right)$$

where

- $V_{OUT}$  is the output voltage
  - $R_{UP}$  the top divider resistor
  - $R_{DOWN}$  is the bottom divider resistor
- (5)

Choose  $R_{DOWN}$  to be approximately 10 k $\Omega$ . Slightly increasing or decreasing  $R_{DOWN}$  can result in closer output voltage matching when using standard value resistors. In this design,  $R_{DOWN} = 10$  k $\Omega$  and  $R_{UP} = 487$  k $\Omega$ , resulting in an output voltage of 60 V.

### 8.2.2.6 Selecting Sample Window

A pulse signal is connected with SAMPLE pin; the minimum window is 350 ns while the frequency of the pulse is lower than 100 kHz.

### 8.2.2.7 Selecting Capacitor for CAP pin

TI recommends placing a ceramic capacitor from CAP pin to GND to lower the noise for the APD current mirror. A ceramic capacitor between 10 nF and 100 nF is recommended from CAP pin to GND.

### 8.2.2.8 Selecting Capacitor for AVCC pin

The control circuitry is powered by AVCC. A ceramic capacitor must be placed close to AVCC, with a typical capacitor value of 2.2  $\mu$ F.

### 8.2.2.9 Selecting Capacitor for APD pin

A ceramic capacitor is required to make the APD current mirror more accurately against the noise coupling. The recommended values are from 100 pF to 470 pF.

### 8.2.2.10 Selecting the Resistors of MON1 or MON2

The TPS61390 provides two currents proportional to APD current on the MON pins, 4 : 5 and 1 : 5. The voltage of the resistors connecting to the MON pins convert the APD current to voltage. The relation between APD current and the voltage on MON 1 or MON 2 pins is shown in [Equation 1](#) and [Equation 2](#).

The resistor value depends on the VSP pin voltage. While RC time constant of MON 1 and MON 2 is recommended to be 1/10 of the sample window time.

### 8.2.2.11 Selecting the Capacitors of MON1 or MON2

The capacitors are added to the MON1 or MON2 pins to decouple the noise of APD transient current. Suggested RC time (formed by the MON1 or MON2 is 1/10 with that of the sample window. With 3-k $\Omega$   $R_{MON}$  resistance, TI recommends a 10-pF capacitor connecting MON1 or MON2 pins to make sure the voltage on MON1 or MON2 is stable before sample signal coming.

It is recommended that RC time constant of MON 1 and MON 2 is around 1/10 of the sample window time.

### 8.2.2.12 Selecting the Resistor of Gain pin

The GAIN pin can be configured as both input and output. If the GAIN pin is configured as output pin, TI recommends that it be directly connected with the external I/O.

If the pin is configured as the input pin to select the current mirror ratio, the pull up or pull down resistor must be lower than 1-k $\Omega$  as there is an internal 5-k $\Omega$  resistor on the GAIN pin.

### 8.2.2.13 Selecting the Short Current Limit

The output current short-protection threshold of the TPS61390 can be programmed by an external resistor with [Equation 6](#). The short protection threshold is calculated by [Equation 1](#) and [Equation 2](#):

$$I_{SHORT} = \frac{100}{R_{SHORT}}$$

where

- $I_{SHORT}$  (mA) is the short protection threshold
- $R_{SHORT}(k\Omega)$  is the resistor connecting from ISHORT pin to GND

For instance, if  $R_{SHORT} = 25\text{ k}\Omega$ , the  $I_{SHORT} = 4\text{ mA}$ .

### 8.2.3 Application Curves

Typical condition  $V_{IN} = 3.3\text{ V}$ ,  $V_{OUT} = 60\text{ V}$ ,  $R_{SHORT} = 5\text{ k}\Omega$ ,  $R_{MON1/2} = 3.01\text{ k}\Omega$  and  $C_{MON1/2} = 10\text{ pF}$ .

Application waveforms are measured with the inductor  $4.7\text{ }\mu\text{H}$  and the output capacitance  $0.1\text{ }\mu\text{F}$  at room temperature.

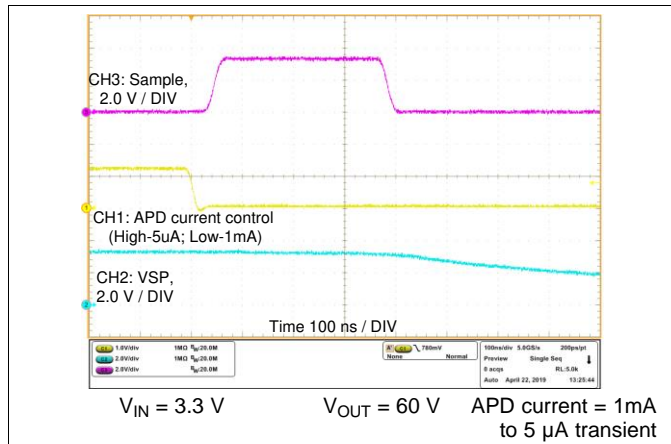

Figure 13. APD current transient

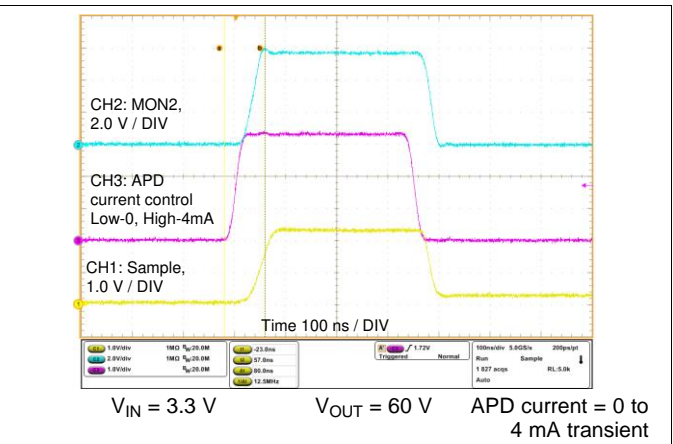

Figure 14. High optical current protection

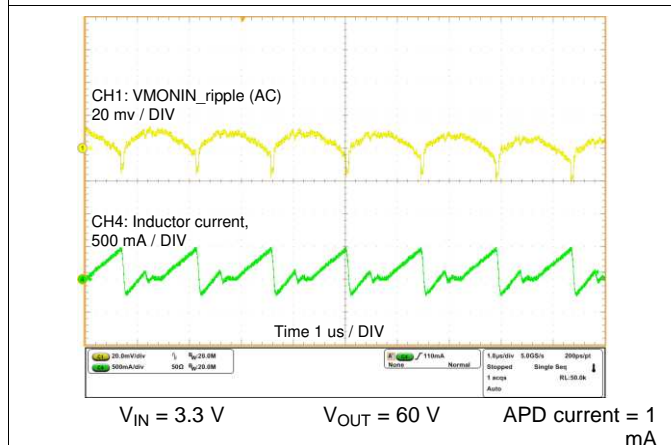

Figure 15. Output voltage ripple with  $100\text{ }\Omega$  /  $0.1\text{ }\mu\text{F}$  filter

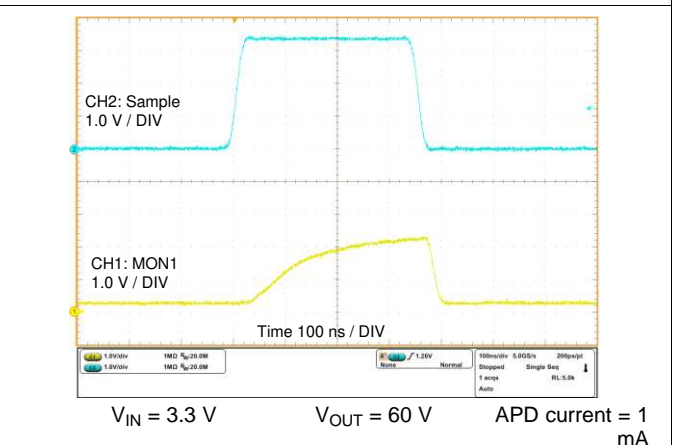
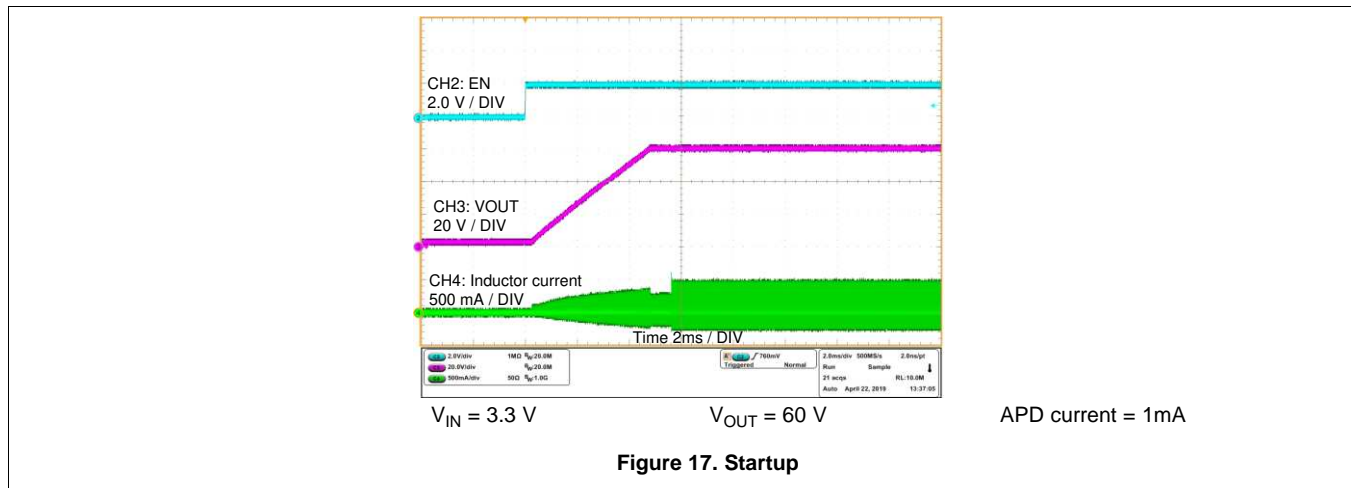

Figure 16. MON 1 settling time



## 9 Power Supply Recommendations

The device is designed to operate from an input voltage supply range between 2.5 V and 5.5 V. This input supply must be well regulated. If the input supply is located more than a few inches from the device, the bulk capacitance may be required in addition to the ceramic bypass capacitors. An electrolytic capacitor with a value of 47  $\mu\text{F}$  is a typical choice.

## 10 Layout

### 10.1 Layout Guidelines

The basic PCB board layout requires a separation of sensitive signal and power paths. If the layout is not carefully done, the regulator could suffer from the instability or noise problems. Use the following checklist to get good performance for a well-designed board:

- Minimize the high current path including the switch FET, rectifier FET, and the output capacitor. This loop contains high  $di/dt$  switching currents (nano seconds per ampere) and easy to transduce the high frequency noise;
- Place the noise sensitive network like sample hold and current mirror output (MON1, MON2) being far away from the SW trace;
- Split the ground for the power GND, signal GND. Use a separate ground trace to connect the sample/hold and boost circuitry. Connect this ground trace to the main power ground at a single point to minimize circulating currents.

### 10.2 Layout Example

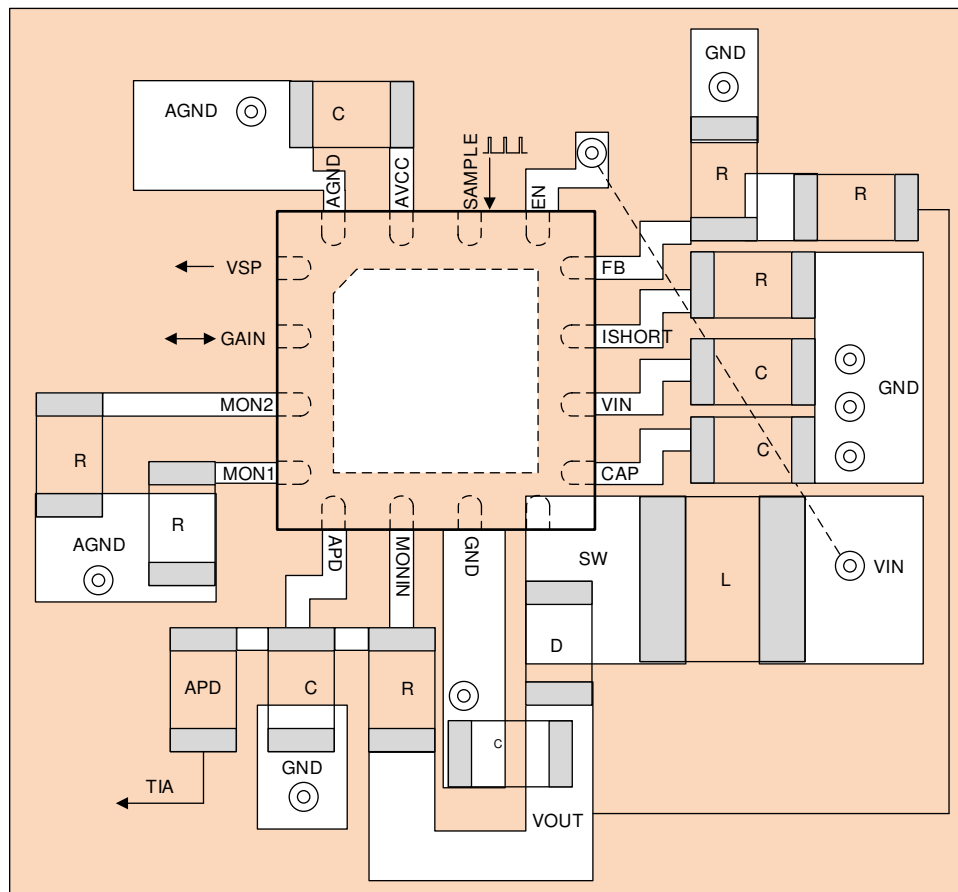

**Figure 18. Layout Example**

## 11 Device and Documentation Support

### 11.1 Receiving Notification of Documentation Updates

To receive notification of documentation updates, navigate to the device product folder on ti.com. In the upper right corner, click on *Alert me* to register and receive a weekly digest of any product information that has changed. For change details, review the revision history included in any revised document.

### 11.2 Community Resources

TI E2E™ support forums are an engineer's go-to source for fast, verified answers and design help — straight from the experts. Search existing answers or ask your own question to get the quick design help you need.

Linked content is provided "AS IS" by the respective contributors. They do not constitute TI specifications and do not necessarily reflect TI's views; see TI's [Terms of Use](#).

### 11.3 Trademarks

E2E is a trademark of Texas Instruments.  
All other trademarks are the property of their respective owners.

### 11.4 Electrostatic Discharge Caution



This integrated circuit can be damaged by ESD. Texas Instruments recommends that all integrated circuits be handled with appropriate precautions. Failure to observe proper handling and installation procedures can cause damage.

ESD damage can range from subtle performance degradation to complete device failure. Precision integrated circuits may be more susceptible to damage because very small parametric changes could cause the device not to meet its published specifications.

### 11.5 Glossary

[SLYZ022](#) — *TI Glossary*.

This glossary lists and explains terms, acronyms, and definitions.

## 12 Mechanical, Packaging, and Orderable Information

The following pages include mechanical, packaging, and orderable information. This information is the most current data available for the designated devices. This data is subject to change without notice and revision of this document. For browser-based versions of this data sheet, refer to the left-hand navigation.

**PACKAGING INFORMATION**

Orderable part number	Status (1)	Material type (2)	Package   Pins	Package qty   Carrier	RoHS (3)	Lead finish/ Ball material (4)	MSL rating/ Peak reflow (5)	Op temp (°C)	Part marking (6)
<a href="#">TPS61390RTER</a>	Active	Production	WQFN (RTE)   16	3000   LARGE T&R	Yes	SN	Level-1-260C-UNLIM	-40 to 125	1XQH
TPS61390RTER.A	Active	Production	WQFN (RTE)   16	3000   LARGE T&R	Yes	SN	Level-1-260C-UNLIM	-40 to 125	1XQH
<a href="#">TPS61390RTET</a>	Active	Production	WQFN (RTE)   16	250   SMALL T&R	Yes	SN	Level-1-260C-UNLIM	-40 to 125	1XQH
TPS61390RTET.A	Active	Production	WQFN (RTE)   16	250   SMALL T&R	Yes	SN	Level-1-260C-UNLIM	-40 to 125	1XQH

(1) **Status:** For more details on status, see our [product life cycle](#).

(2) **Material type:** When designated, preproduction parts are prototypes/experimental devices, and are not yet approved or released for full production. Testing and final process, including without limitation quality assurance, reliability performance testing, and/or process qualification, may not yet be complete, and this item is subject to further changes or possible discontinuation. If available for ordering, purchases will be subject to an additional waiver at checkout, and are intended for early internal evaluation purposes only. These items are sold without warranties of any kind.

(3) **RoHS values:** Yes, No, RoHS Exempt. See the [TI RoHS Statement](#) for additional information and value definition.

(4) **Lead finish/Ball material:** Parts may have multiple material finish options. Finish options are separated by a vertical ruled line. Lead finish/Ball material values may wrap to two lines if the finish value exceeds the maximum column width.

(5) **MSL rating/Peak reflow:** The moisture sensitivity level ratings and peak solder (reflow) temperatures. In the event that a part has multiple moisture sensitivity ratings, only the lowest level per JEDEC standards is shown. Refer to the shipping label for the actual reflow temperature that will be used to mount the part to the printed circuit board.

(6) **Part marking:** There may be an additional marking, which relates to the logo, the lot trace code information, or the environmental category of the part.

Multiple part markings will be inside parentheses. Only one part marking contained in parentheses and separated by a "~" will appear on a part. If a line is indented then it is a continuation of the previous line and the two combined represent the entire part marking for that device.

**Important Information and Disclaimer:** The information provided on this page represents TI's knowledge and belief as of the date that it is provided. TI bases its knowledge and belief on information provided by third parties, and makes no representation or warranty as to the accuracy of such information. Efforts are underway to better integrate information from third parties. TI has taken and continues to take reasonable steps to provide representative and accurate information but may not have conducted destructive testing or chemical analysis on incoming materials and chemicals. TI and TI suppliers consider certain information to be proprietary, and thus CAS numbers and other limited information may not be available for release.

In no event shall TI's liability arising out of such information exceed the total purchase price of the TI part(s) at issue in this document sold by TI to Customer on an annual basis.

## TAPE AND REEL INFORMATION



### QUADRANT ASSIGNMENTS FOR PIN 1 ORIENTATION IN TAPE



\*All dimensions are nominal

Device	Package Type	Package Drawing	Pins	SPQ	Reel Diameter (mm)	Reel Width W1 (mm)	A0 (mm)	B0 (mm)	K0 (mm)	P1 (mm)	W (mm)	Pin1 Quadrant
TPS61390RTER	WQFN	RTE	16	3000	330.0	12.4	3.3	3.3	1.1	8.0	12.0	Q2
TPS61390RTET	WQFN	RTE	16	250	180.0	12.4	3.3	3.3	1.1	8.0	12.0	Q2

**TAPE AND REEL BOX DIMENSIONS**

\*All dimensions are nominal

Device	Package Type	Package Drawing	Pins	SPQ	Length (mm)	Width (mm)	Height (mm)
TPS61390RTER	WQFN	RTE	16	3000	367.0	367.0	35.0
TPS61390RTET	WQFN	RTE	16	250	210.0	185.0	35.0

## GENERIC PACKAGE VIEW

**RTE 16**

**WQFN - 0.8 mm max height**

3 x 3, 0.5 mm pitch

PLASTIC QUAD FLATPACK - NO LEAD

This image is a representation of the package family, actual package may vary.  
Refer to the product data sheet for package details.

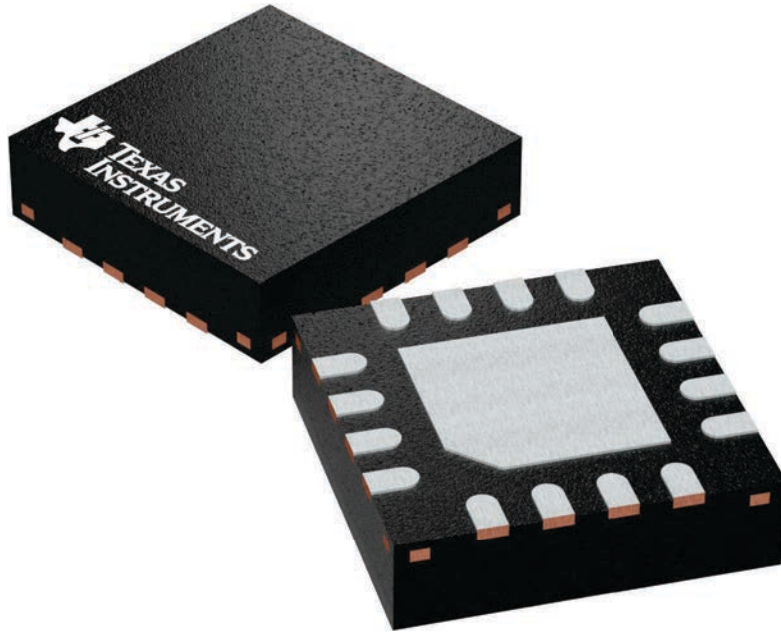

4225944/A

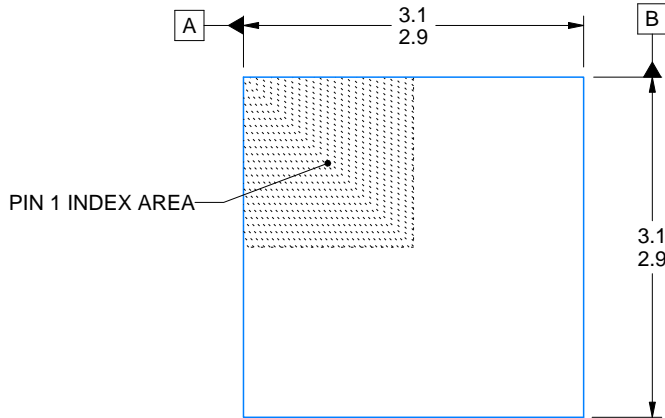

SIDE WALL METAL THICKNESS DIM A	
OPTION 1	OPTION 2
0.1	0.2

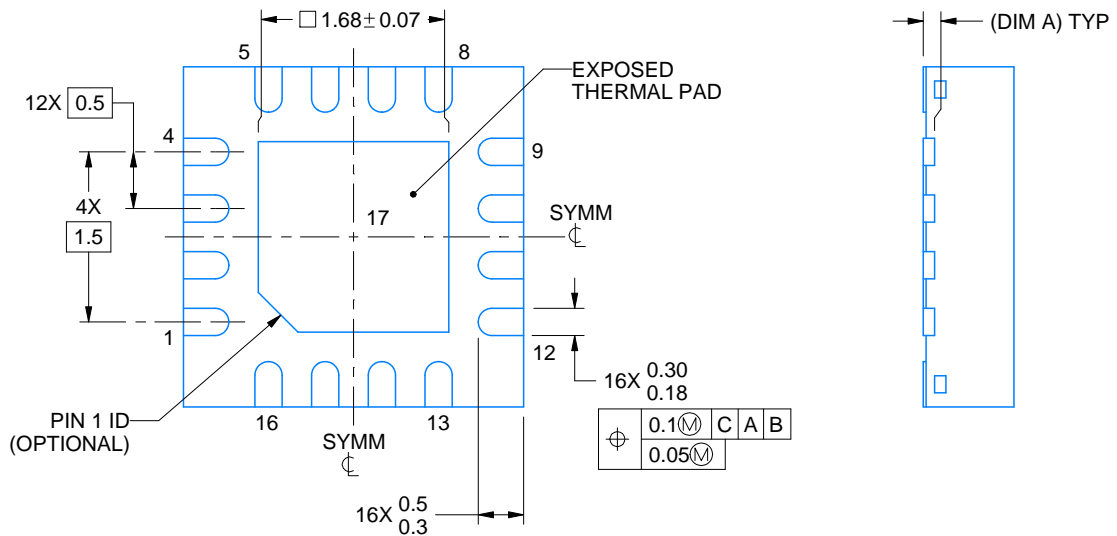
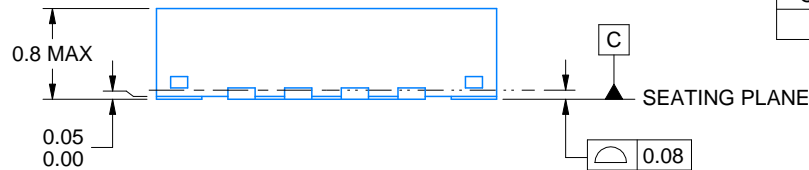

4219117/B 04/2022

NOTES:

1. All linear dimensions are in millimeters. Any dimensions in parenthesis are for reference only. Dimensioning and tolerancing per ASME Y14.5M.
2. This drawing is subject to change without notice.
3. The package thermal pad must be soldered to the printed circuit board for thermal and mechanical performance.

# EXAMPLE BOARD LAYOUT

RTE0016C

WQFN - 0.8 mm max height

PLASTIC QUAD FLATPACK - NO LEAD

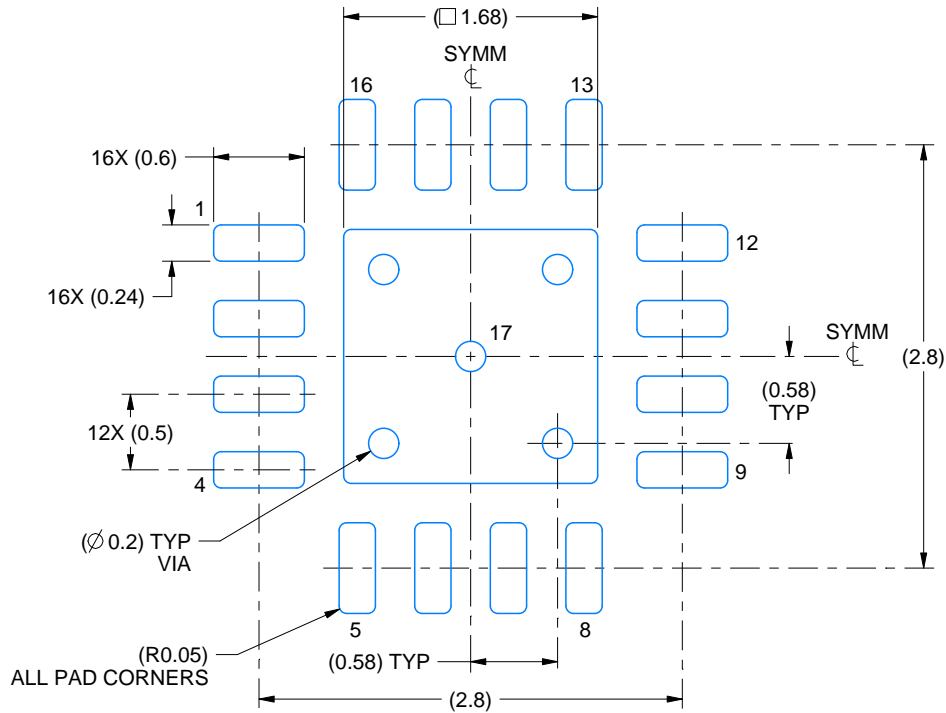

LAND PATTERN EXAMPLE  
EXPOSED METAL SHOWN  
SCALE:20X

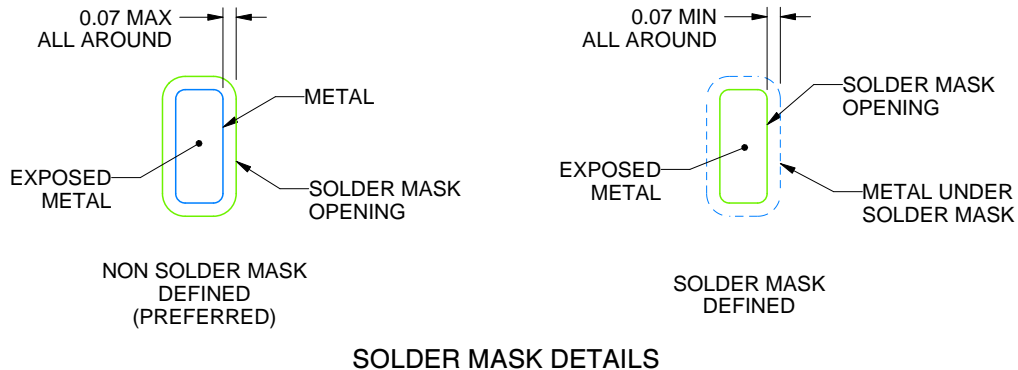

SOLDER MASK DETAILS

4219117/B 04/2022

NOTES: (continued)

- This package is designed to be soldered to a thermal pad on the board. For more information, see Texas Instruments literature number SLUA271 ([www.ti.com/lit/sl原因271](http://www.ti.com/lit/sl原因271)).
- Vias are optional depending on application, refer to device data sheet. If any vias are implemented, refer to their locations shown on this view. It is recommended that vias under paste be filled, plugged or tented.

# EXAMPLE STENCIL DESIGN

RTE0016C

WQFN - 0.8 mm max height

PLASTIC QUAD FLATPACK - NO LEAD

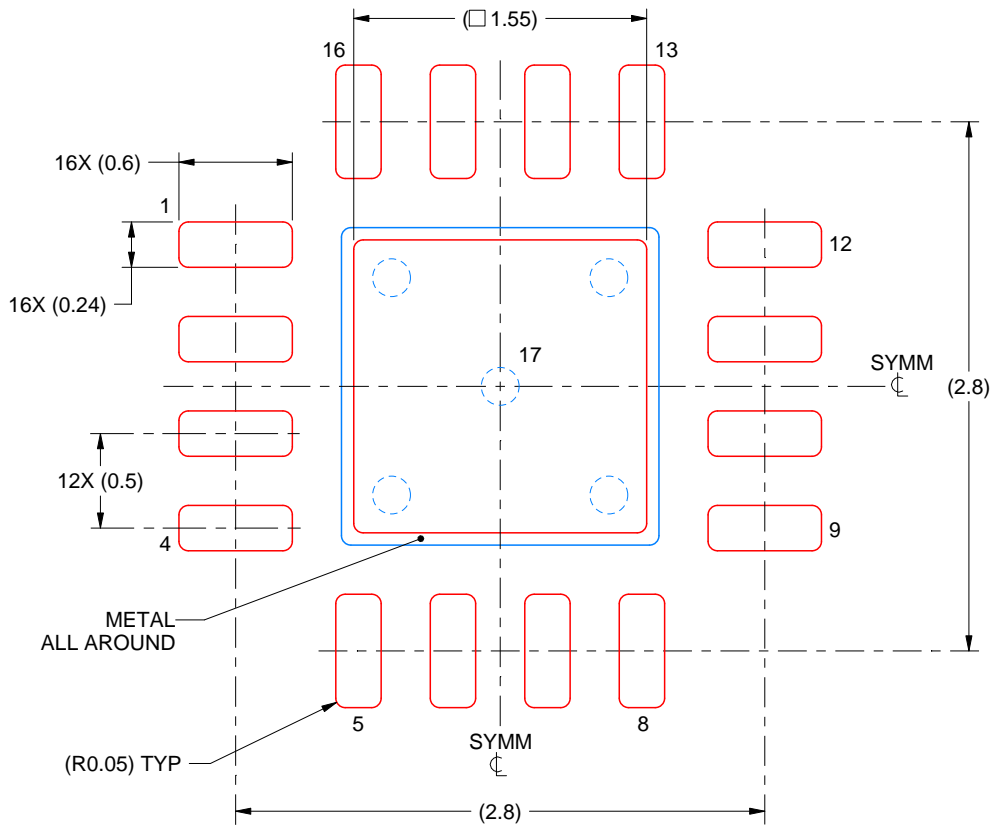

**SOLDER PASTE EXAMPLE**  
BASED ON 0.125 mm THICK STENCIL

EXPOSED PAD 17:  
85% PRINTED SOLDER COVERAGE BY AREA UNDER PACKAGE  
SCALE:25X

4219117/B 04/2022

NOTES: (continued)

6. Laser cutting apertures with trapezoidal walls and rounded corners may offer better paste release. IPC-7525 may have alternate design recommendations.

## IMPORTANT NOTICE AND DISCLAIMER

TI PROVIDES TECHNICAL AND RELIABILITY DATA (INCLUDING DATASHEETS), DESIGN RESOURCES (INCLUDING REFERENCE DESIGNS), APPLICATION OR OTHER DESIGN ADVICE, WEB TOOLS, SAFETY INFORMATION, AND OTHER RESOURCES "AS IS" AND WITH ALL FAULTS, AND DISCLAIMS ALL WARRANTIES, EXPRESS AND IMPLIED, INCLUDING WITHOUT LIMITATION ANY IMPLIED WARRANTIES OF MERCHANTABILITY, FITNESS FOR A PARTICULAR PURPOSE OR NON-INFRINGEMENT OF THIRD PARTY INTELLECTUAL PROPERTY RIGHTS.

These resources are intended for skilled developers designing with TI products. You are solely responsible for (1) selecting the appropriate TI products for your application, (2) designing, validating and testing your application, and (3) ensuring your application meets applicable standards, and any other safety, security, regulatory or other requirements.

These resources are subject to change without notice. TI grants you permission to use these resources only for development of an application that uses the TI products described in the resource. Other reproduction and display of these resources is prohibited. No license is granted to any other TI intellectual property right or to any third party intellectual property right. TI disclaims responsibility for, and you fully indemnify TI and its representatives against any claims, damages, costs, losses, and liabilities arising out of your use of these resources.

TI's products are provided subject to [TI's Terms of Sale](#), [TI's General Quality Guidelines](#), or other applicable terms available either on [ti.com](http://ti.com) or provided in conjunction with such TI products. TI's provision of these resources does not expand or otherwise alter TI's applicable warranties or warranty disclaimers for TI products. Unless TI explicitly designates a product as custom or customer-specified, TI products are standard, catalog, general purpose devices.

TI objects to and rejects any additional or different terms you may propose.

Copyright © 2026, Texas Instruments Incorporated

Last updated 10/2025