

250mA Dual Outputs AMOLED Display Power Supply

Check for Samples: [TPS65137AS](#)

FEATURES

- 2.5 V to 4.8 V Input Voltage Range
- 0.8% Output Voltage Accuracy V_{POS}
- Excellent Line Transient Regulation
- 250 mA Output Current
- Fixed 4.6 V V_{POS} Output Voltage
- Digitally Programmable V_{NEG} , -2.2V to -5.2V
- -4.9V Default Value for V_{NEG}
- Short Circuit Protection
- Thermal Shutdown
- 3mm × 3mm 10-Pin QFN Package

DESCRIPTION

The TPS65137AS is designed to drive AMOLED displays (Active Matrix Organic Light Emitting Diode) requiring positive and negative voltage supply rails. The device integrates a boost converter with LDO post regulator and an inverting buckboost converter suitable for battery operated products. The digital control pin (CTRL) allows programming the negative output voltage in digital steps. The TPS65137AS uses a novel technology enabling excellent line and load regulation. This is required to avoid disturbance of the AMOLED display by the input voltage regulation during transmit periods in mobile phones.

APPLICATIONS

- Active Matrix OLED

TYPICAL APPLICATION

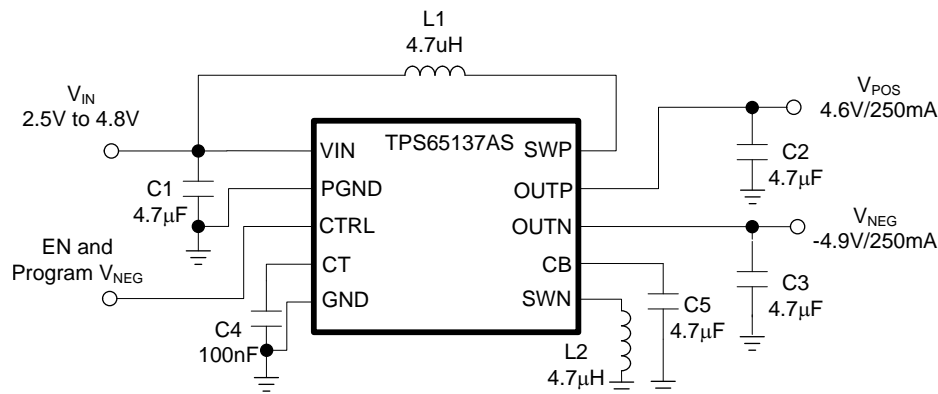

Please be aware that an important notice concerning availability, standard warranty, and use in critical applications of Texas Instruments semiconductor products and disclaimers thereto appears at the end of this data sheet.



This integrated circuit can be damaged by ESD. Texas Instruments recommends that all integrated circuits be handled with appropriate precautions. Failure to observe proper handling and installation procedures can cause damage.

ESD damage can range from subtle performance degradation to complete device failure. Precision integrated circuits may be more susceptible to damage because very small parametric changes could cause the device not to meet its published specifications.

ORDERING INFORMATION^{(1) (2)}

T _A	PACKAGE ⁽²⁾	ORDERABLE PART NUMBER	TOP-SIDE MARKING
-40°C to 85°C	10-Pin 3x3 QFN	TPS65137ASDSCR	PPGC

- (1) For the most current package and ordering information, see the Package Option Addendum at the end of this document, or see the TI web site at www.ti.com.
- (2) Package drawings, thermal data, and symbolization are available at www.ti.com/packaging.

ABSOLUTE MAXIMUM RATINGS

over operating free-air temperature range (unless otherwise noted)⁽¹⁾

		VALUE		UNIT
		MIN	MAX	
Pin Voltage ⁽²⁾	PVIN, SWP, OUTP, CTRL, VL, CB		5.5	V
	OUTN		-6.5	V
	SWN	-6.5	5.5	V
	CT		3.6	V
ESD rating	HBM		2	kV
	MM		200	V
	CDM		500	V
T _J	Operating junction temperature range	-40	50	°C
T _A	Operating ambient temperature range	-40	85	°C
T _{stg}	Storage temperature range	-65	150	°C

- (1) Stresses beyond those listed under *absolute maximum ratings* may cause permanent damage to the device. These are stress ratings only, and functional operation of the device at these or any other conditions beyond those indicated under *recommended operating conditions* is not implied. Exposure to absolute-maximum-rated conditions for extended periods may affect device reliability.
- (2) With respect to GND pin.

THERMAL INFORMATION

THERMAL METRIC ⁽¹⁾		TPS65137AS	UNITS
		DSC	
		10	
θ _{JA}	Junction-to-ambient thermal resistance	56.5	°C/W
θ _{JB}	Junction-to-board thermal resistance	25.2	
ψ _{JT}	Junction-to-top characterization parameter	1.0	
ψ _{JB}	Junction-to-board characterization parameter	17.9	

- (1) For more information about traditional and new thermal metrics, see the IC Package Thermal Metrics application report, [SPRA953](#).

RECOMMENDED OPERATING CONDITIONS

		MIN	TYP	MAX	UNIT
V _{IN}	Input supply voltage range	2.5	3.7	4.8	V
T _A	Operating ambient temperature	-40	25	85	°C
T _J	Operating junction temperature	-40	85	125	°C

ELECTRICAL CHARACTERISTICS

$V_{IN} = 3.7V$, $CTRL = V_{IN}$, $V_{POS} = 4.6V$, $V_{NEG} = -4.9V$, $T_A = -40^{\circ}C$ to $85^{\circ}C$, typical values are at $T_A = 25^{\circ}C$ (unless otherwise noted)

PARAMETER		TEST CONDITIONS	MIN	TYP	MAX	UNIT
SUPPLY CURRENT AND THERMAL PROTECTION						
V_{IN}	Input voltage range		2.5		4.8	V
I_Q	Operating quiescent current into V_{IN}	V_{POS} and V_{NEG} have no load ⁽¹⁾		16		mA
I_{SD}	Shutdown current into V_{IN}	$CTRL = GND$		0.1		μA
V_{UVLO}	Under-voltage lockout threshold	V_{IN} falling			2.0	V
		V_{IN} rising			2.3	
	Thermal shutdown			145		$^{\circ}C$
OUTPUT V_{POS}						
V_{POS}	Positive output voltage regulation		-0.8%	4.6	0.8%	V
$r_{DS(ON)}$	SWP MOSFET on-resistance	$I_{SWP} = 200$ mA		200		$m\Omega$
	SWP MOSFET rectifier on-resistance	$I_{SWP} = 200$ mA		250		$m\Omega$
f_{SWP}	SWP Switching frequency	$I_{POS} = 0$ mA		1.6		MHz
I_{SWP}	SWP switch current limit	Inductor valley current	0.9	1.2		A
$V_{P(SCP)}$	Short circuit threshold in operation	V_{POS} falling		3.7		V
I_{PLEAK}	Leakage current into V_{POS}	$CTRL = GND$		2	5	μA
V_{DROP}	LDO drop out voltage	$I_{POS} = 100$ mA		400		mV
	Line regulation	$I_{POS} = 0$ mA		0		%/V
	Load regulation	$I_{POS} = 0$ to 250 mA		0.28		%/A
OUTPUT V_{NEG}						
V_{NEG}	Negative output voltage default			-4.9		V
	Negative output voltage range		-2.2		-5.2	V
	Negative output voltage regulation	$-5.2 \leq V_{NEG} \leq -4.2$		-1%		1%
$-4.2 < V_{NEG} \leq -2.2$			-1.5%		1.5%	
$r_{DS(ON)}$	SWN MOSFET on-resistance	$I_{SWN} = 200$ mA		200		$m\Omega$
	SWN MOSFET rectifier on-resistance	$I_{SWN} = 200$ mA		300		
f_{SWN}	SWN switching frequency	$I_{NEG} = 100$ mA		1.7		MHz
I_{SWN}	SWN switch current limit	$V_{IN} = 2.9$ V	1.2	2.2		A
$V_{N(SCP)}$	Short circuit threshold in operation	Voltage drop from programmed V_{NEG}		420		mV
	Short circuit threshold in start-up		0.18	0.21	0.24	V
$t_{N(SCP)}$	Short circuit detection time in start-up			10		ms
I_{NLEAK}	Leakage current out of V_{NEG}	$CTRL = GND$		2	5	μA
$R_{N(PD)}$	V_{NEG} Pull down resistor before start up	$I_{NEG} = 1$ mA		300		Ω
	Line regulation			0		%/V
	Load regulation	$I_{NEG} = 0$ to 250 mA		0.28		%/A
CTRL INTERFACE						
V_H	Logic high-level voltage		1.2			V
V_L	Logic low-level voltage				0.4	V
R	Pull down resistor		150	400	860	k Ω
t_{INIT}	Initialization time			300	400	μs
t_{OFF}	Shutdown time period		30		80	μs
t_{HIGH}	Pulse high level time period		2	10	25	μs
t_{LOW}	Pulse low level time period		2	10	25	μs
t_{STORE}	Data storage/accept time period		30		80	μs
R_T	C_T pin output impedance		150	325	500	k Ω

(1) With inductor DFE252012C 4.7 μH from TOKO

DEVICE INFORMATION

**10 PIN TQFN PACKAGE
(TOP VIEW)**

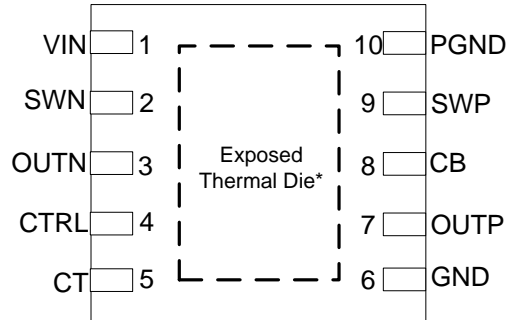

Pin Functions

PIN		I/O ⁽¹⁾	DESCRIPTION
NO.	NAME		
1	VIN	I	Input supply for the negative buck-boost converter generating V_{NEG}
2	SWN	I	Switch pin of the negative buck-boost converter
3	OUTN	O	Output of negative buck-boost converter
4	CTRL	I	Combined enable and V_{NEG} programming pin.
5	CT	O	Sets the settling time for the voltage on V_{NEG} when programmed to a new value
6	GND	G	Analog ground
7	OUTP	O	Output of the boost converter
8	CB	O	Internal boost converter bypass capacitor
9	SWP	I	Switch pin of the boost converter
10	PGND	G	Power ground of boost converter
Exposed thermal die		G	Connect this pad to analog GND.

(1) G = Ground, I = Input, O = Output

FUNCTIONAL BLOCK DIAGRAM

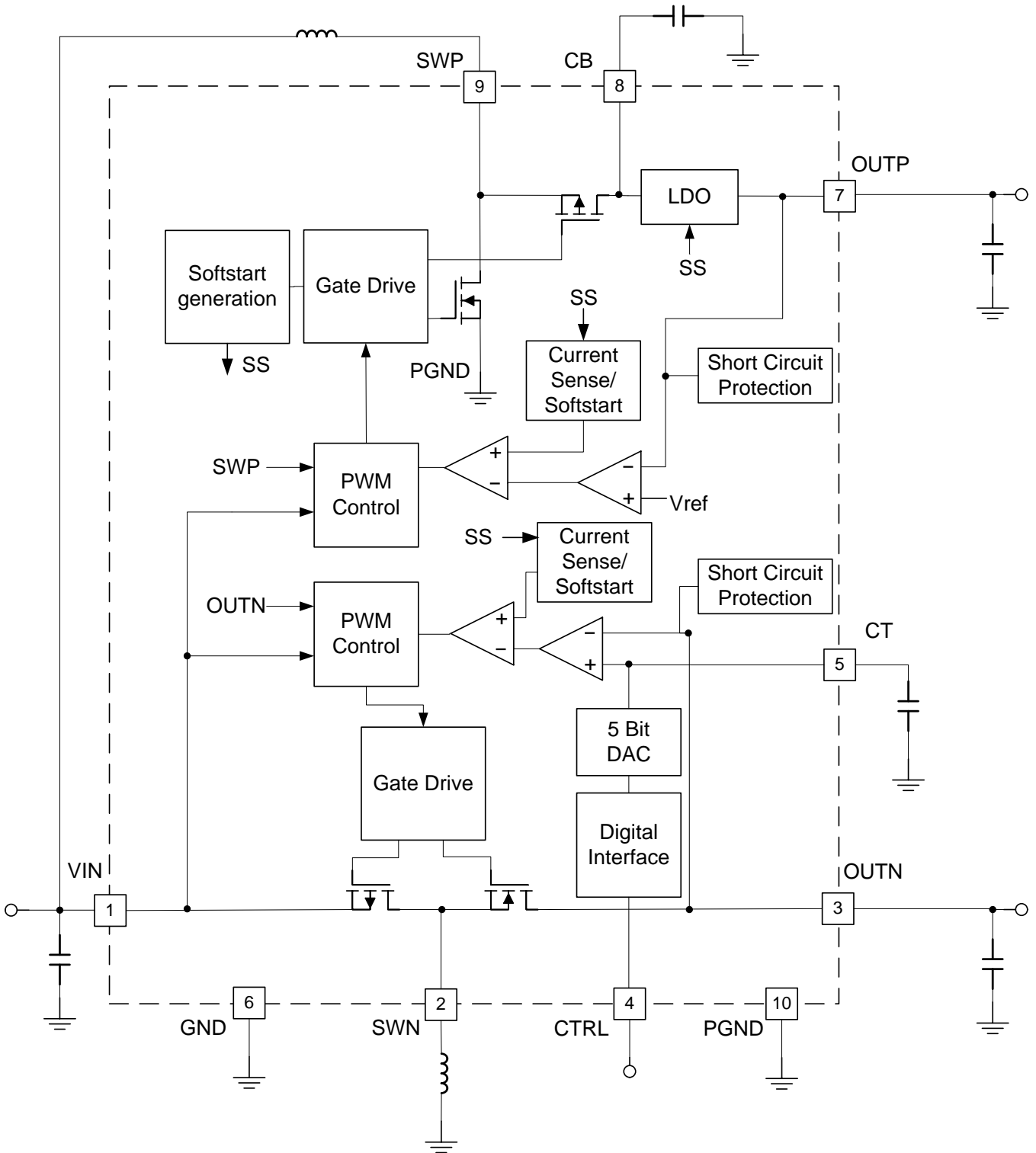

TYPICAL CHARACTERISTICS

TABLE OF GRAPHS

		FIGURE
Efficiency versus Output current (Output current is from V_{POS} to V_{NEG})	$V_{POS} = 4.6\text{ V}$, $V_{NEG} = -4.9\text{ V}$	Figure 1
Startup		Figure 2
Switch pins and output waveforms (Output current is from V_{POS} to V_{NEG})	$I_{OUT} = 100\text{ mA}$, Boost and BuckBoost	Figure 3
	$I_{OUT} = 250\text{ mA}$, Boost and BuckBoost	Figure 4
	$I_{OUT} = 250\text{ mA}$, Boost	Figure 5
	$I_{OUT} = 250\text{ mA}$, BuckBoost	Figure 6

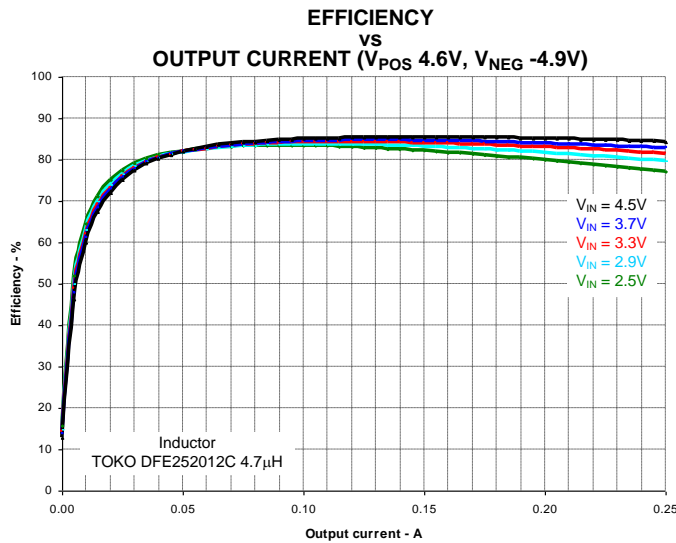

Figure 1.

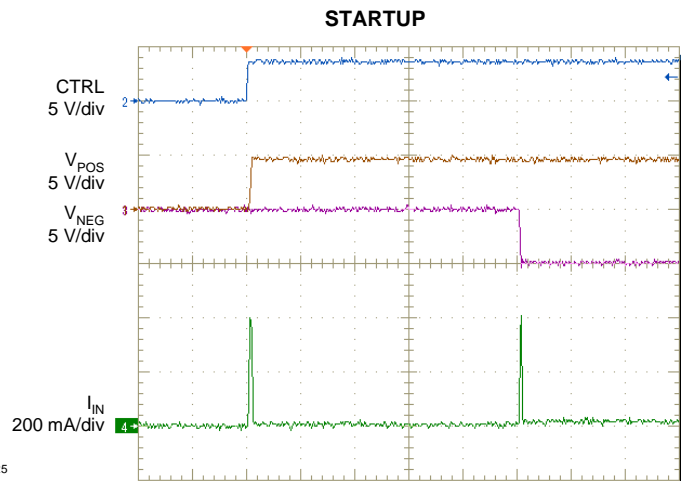

Figure 2.

SWITCH PINS AND OUTPUTS BOOST AND BUCKBOOST, $I_{OUT} 100\text{mA}$

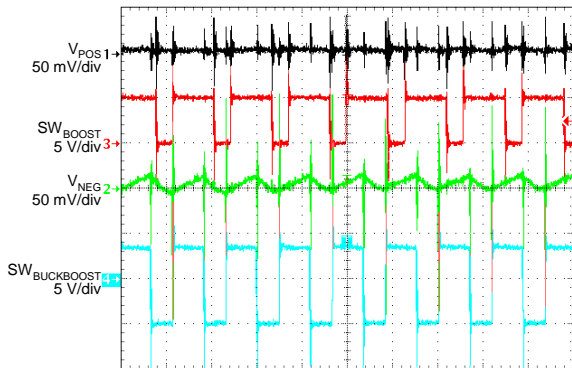

Figure 3.

SWITCH PINS AND OUTPUTS BOOST AND BUCKBOOST, $I_{OUT} 250\text{mA}$

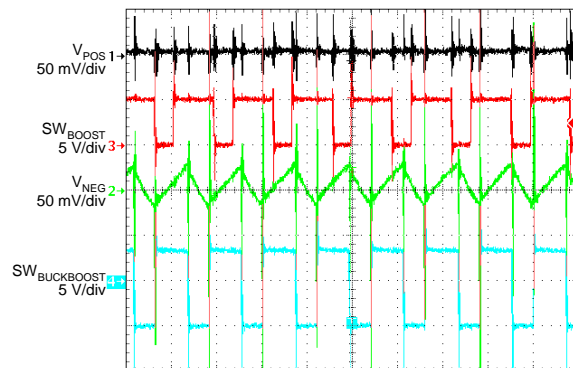
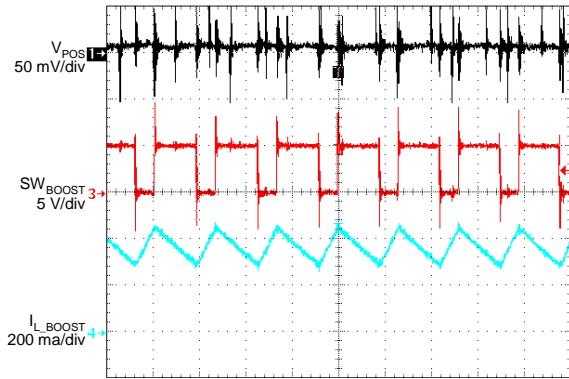

Figure 4.

SWITCH PINS AND OUTPUTS BOOST, I_{OUT} 250mA



500 ns/div
Figure 5.

SWITCH PINS AND OUTPUTS BUCKBOOST, I_{OUT} 250mA

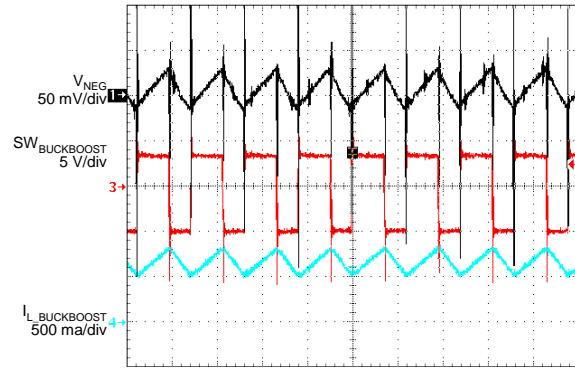

500 ns/div
Figure 6.

APPLICATION FOR TYPICAL CHARACTERISTICS

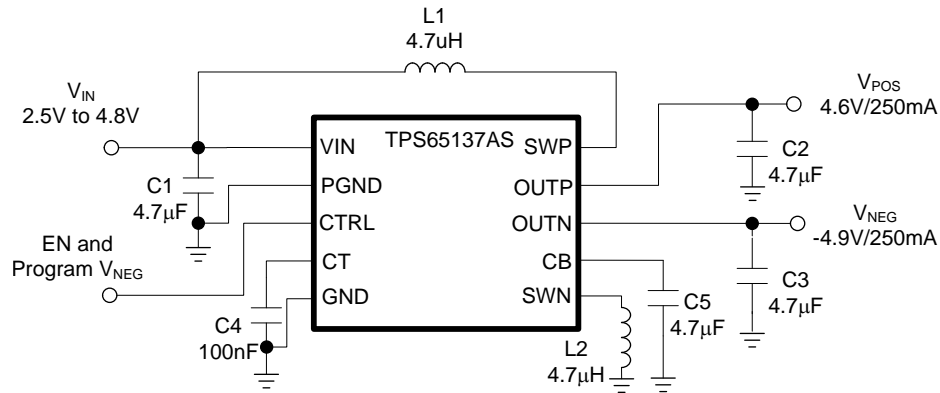

Figure 7. Application for Typical Characteristics

Table 1. Bill of Materials for Typical Characteristics

	Value	Part Number	Manufacturer
C1, C2, C3, C5	4.7 µF, X5R	GRM21BR61C475KA88	Murata
C4	100 nF, X7R	GRM21BR71E104KA01	Murata
L1, L2	4.7 µH	DFE252012C 4.7 µH	TOKO

DETAILED DESCRIPTION

The TPS65137AS consists of a boost converter using an LDO as post regulator and an inverting buck-boost converter. The positive output is fixed at 4.6V. The negative output is programmable by a digital interface in the range of -2.2V to -5.2V , the default is -4.9V . The transition time of the negative output is adjustable by the CT pin capacitor.

SOFT START and START-UP SEQUENCE

The device has a soft start to limit the in-rush current. When the device is enabled by the CTRL pin going HIGH, the boost converter starts with a reduced switch current limit. 8ms after CTRL going HIGH, the buck-boost converter starts with the default value of -4.9V . The typical start-up sequence is shown in [Figure 8](#).

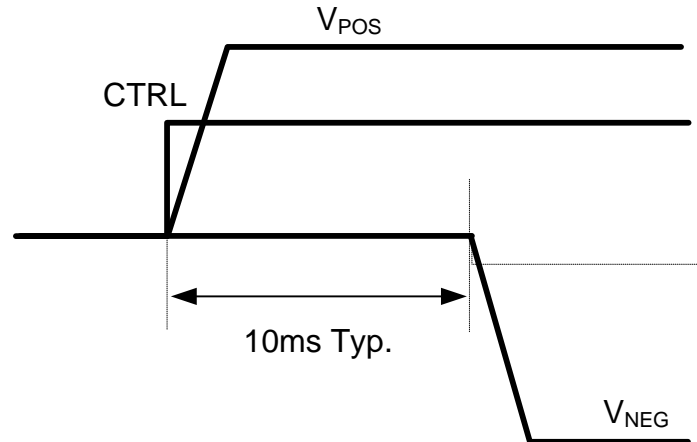

Figure 8. Start-up Sequence

SHORT CIRCUIT PROTECTION

The device is protected against short circuits of the outputs to ground and short circuit of the outputs to each other. During normal operation, an error condition is detected if V_{POS} falls below 3.7V for more than 3ms or V_{NEG} gets above 420mV above the programmed value for more than 3ms. In either case, the device goes into shutdown and this state is latched. The input and the outputs are disconnected. To resume normal operation, V_{IN} has to cycle below UVLO or CTRL has to toggle LOW and HIGH.

During start up, an error condition is detected in the following cases:

- V_{POS} is not in regulation 10ms after CTRL goes HIGH.
- V_{NEG} is higher than threshold level 10ms after CTRL goes HIGH.
- V_{NEG} is not in regulation 20ms after CTRL goes HIGH.

In the above cases, the device goes into shutdown and this state is latched. The input and the outputs are disconnected. To resume normal operation, V_{IN} has to cycle below UVLO or CTRL has to toggle LOW and HIGH.

ENABLE (CTRL PIN)

The CTRL pin serves two functions. One is to enable and disable the device the other is the output voltage programming of the device. If the digital interface is not required the CTRL pin can be used as a standard enable pin for the device and the device will come up with its default value on V_{NEG} of -4.9V . When CTRL is pulled high, the device is enabled. The device is shut down with CTRL low.

DIGITAL INTERFACE (CTRL)

The digital interface allows programming the negative output voltage V_{NEG} in digital steps. If the digital output voltage setting is not required then the CTRL pin can also be used as a standard enable pin.

The digital output voltage programming of V_{NEG} is implemented by a simple digital interface with the timing shown in Figure 9.

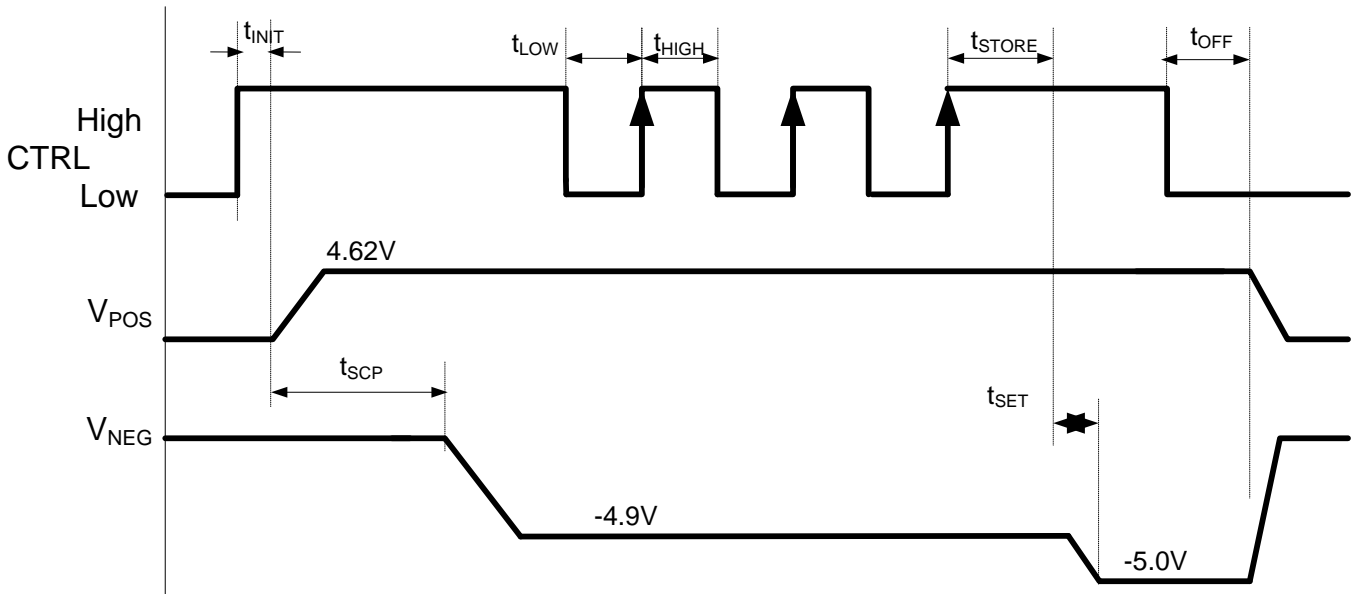

Figure 9. Digital Interface Using CTRL

Once CTRL is pulled high the device will come up with its default voltage of $-4.9V$. The device has a 6-bit DAC implemented with the corresponding output voltages as given in the table below. The interface counts now the rising edges applied to the CTRL pin once the device is enabled. For the example above, V_{NEG} is programmed to $-5.0V$ since 3 rising edges are detected. Other output voltages can be programmed according Table 2.

Table 2. Programming Table for V_{NEG}

BIT/RISING EDGES	V_{NEG}	DAC VALUE	BIT/RISING EDGES	V_{NEG}	DAC VALUE
0/ no pulse	$-4.9 V$	00000	16	$-3.7 V$	10000
1	$-5.2 V$	00001	17	$-3.6 V$	10001
2	$-5.1 V$	00010	18	$-3.5 V$	10010
3	$-5.0 V$	00011	19	$-3.4 V$	10011
4	$-4.9 V$	00100	20	$-3.3 V$	10100
5	$-4.8 V$	00101	21	$-3.2 V$	10101
6	$-4.7 V$	00110	22	$-3.1 V$	10110
7	$-4.6 V$	00111	23	$-3.0 V$	10111
8	$-4.5 V$	01000	24	$-2.9 V$	11000
9	$-4.4 V$	01001	25	$-2.8 V$	11001
10	$-4.3 V$	01010	26	$-2.7 V$	11010
11	$-4.2 V$	01011	27	$-2.6 V$	11011
12	$-4.1 V$	01100	28	$-2.5 V$	11100
13	$-4.0 V$	01101	29	$-2.4 V$	11101
14	$-3.9 V$	01110	30	$-2.3 V$	11110
15	$-3.8 V$	01111	31	$-2.2 V$	11111

SETTING TRANSITION TIME t_{set} for V_{NEG} (C_T)

The device allows setting the transition time t_{set} using an external capacitor connected to pin CT. The transition time is the time period required to move V_{NEG} from one voltage level to the next programmed voltage level. The capacitor connected to pin CT does not influence the soft start time t_{ss} of the V_{NEG} default value. When the CT pin is left open then the shortest possible transition time is programmed. When connecting a capacitor to the CT pin then the transition time is given by an R-C time constant. This is given by the output impedance of the CT pin typically 325k Ω and the external capacitance. Within one τ the output voltage V_{NEG} has reached 70% of its programmed value. An example is given when using 100nF for C_T .

$$\tau \approx t_{set70\%} = 325 \text{ k}\Omega \times C_T = 325 \text{ k}\Omega \times 100 \text{ nF} = 32.5 \text{ mS}$$

The output voltage is almost at its programmed value after 3τ .

PCB LAYOUT

Figure 10 and Figure 11 show an example of a PCB layout design.

1. Place the input capacitor on VIN and the output capacitor on OUTN as close as possible to the device.
Use short and wide traces to connect the input capacitor to VIN and the output capacitor to OUTN.
2. Place the output capacitor on OOTP and the capacitor on CB as close as possible to the device.
Use short and wide traces to connect the output capacitor to OOTP.
3. Connect the ground of the CT capacitor to the GND pin, pin 6, directly.
4. Connect the input ground and the output ground on the same board layer, not through vias.

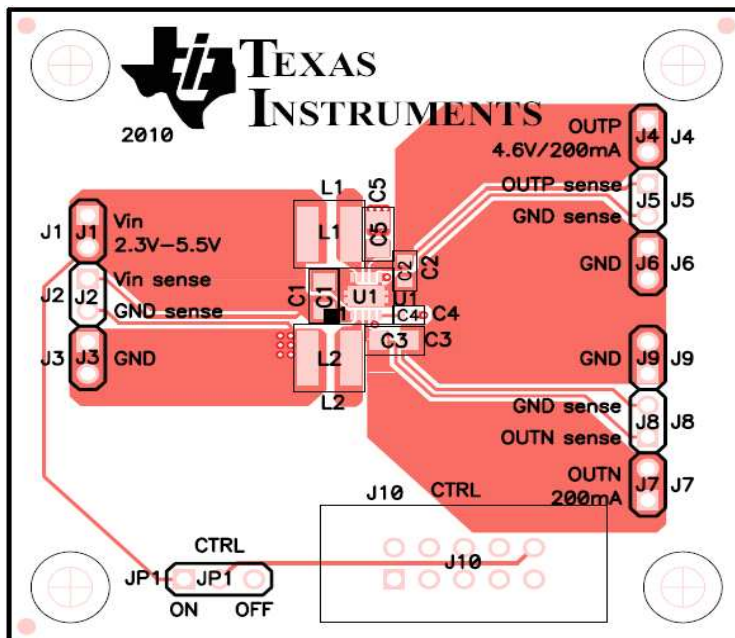

Figure 10. Example of PCB Layout Design (Top layer)

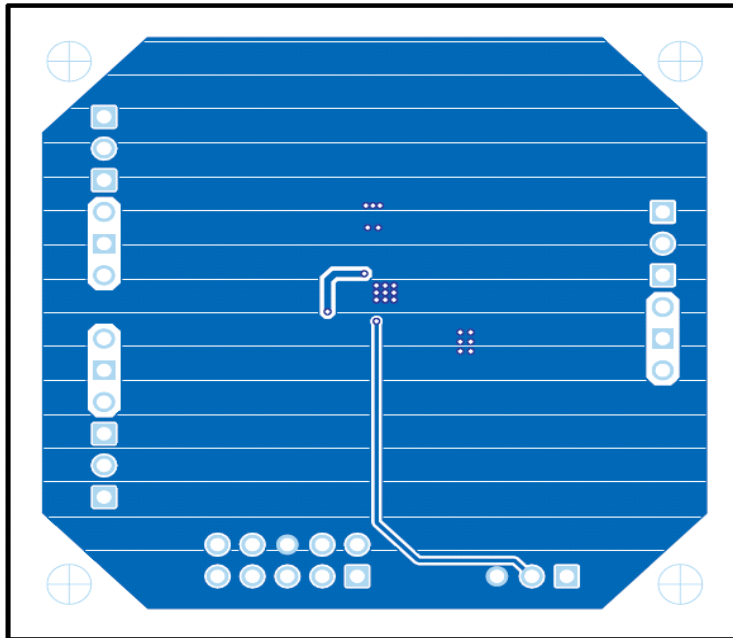

Figure 11. Example of PCB Layout Design (Bottom layer)

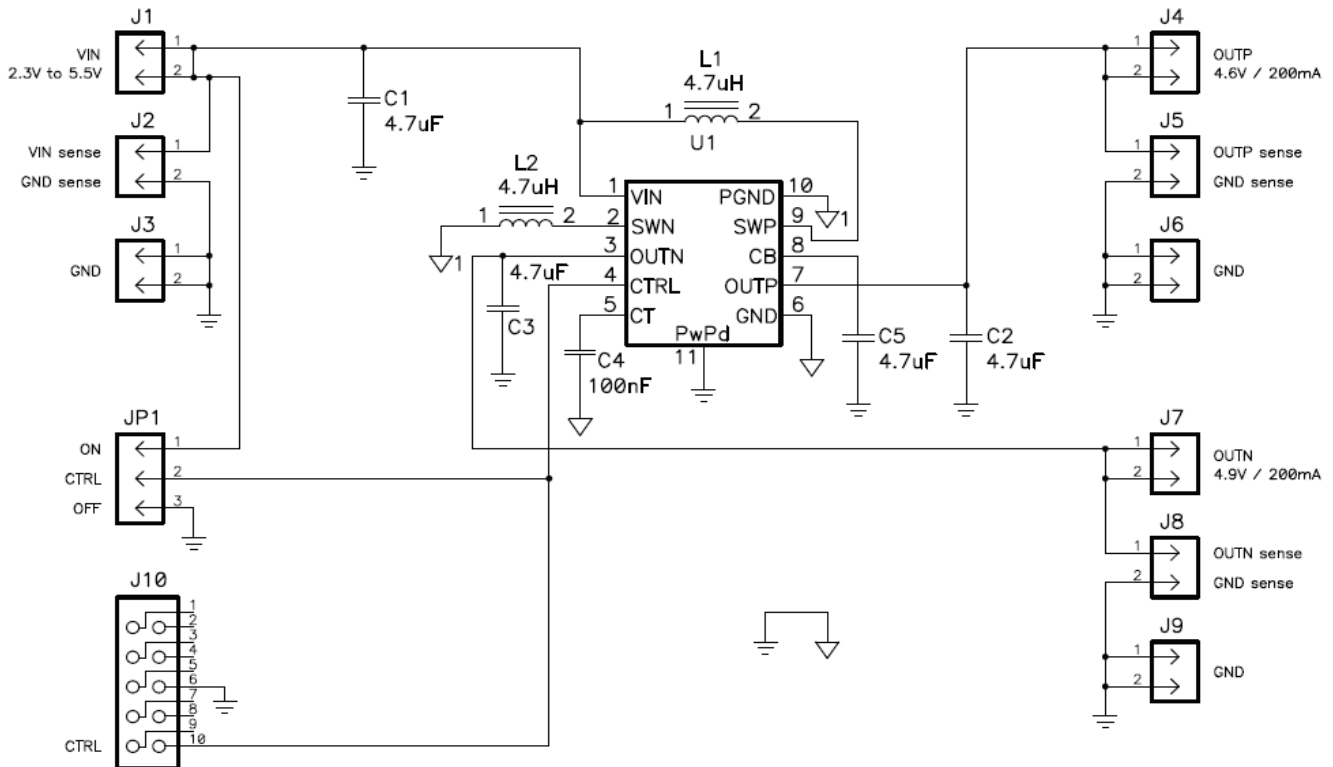

Figure 12. Schematic for the Example of PCB Layout Design

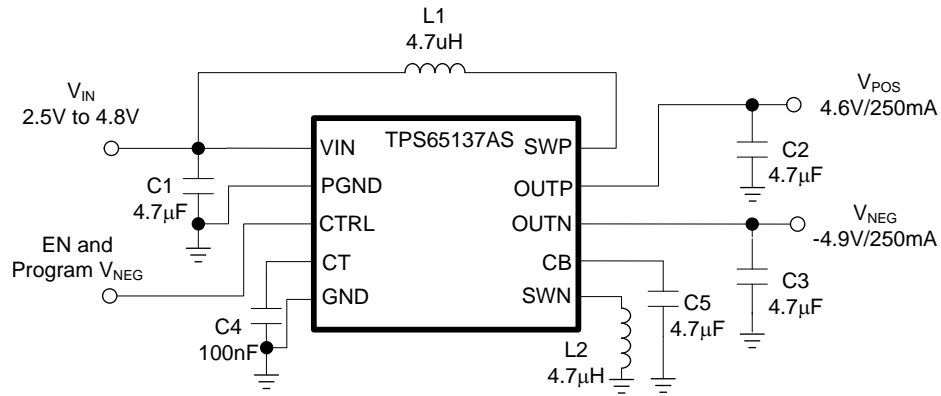

Figure 13. Typical Application Circuit

PACKAGING INFORMATION

Orderable part number	Status (1)	Material type (2)	Package Pins	Package qty Carrier	RoHS (3)	Lead finish/ Ball material (4)	MSL rating/ Peak reflow (5)	Op temp (°C)	Part marking (6)
TPS65137ASDSCR	Active	Production	WSON (DSC) 10	3000 LARGE T&R	Yes	NIPDAU	Level-2-260C-1 YEAR	-40 to 85	PPGC
TPS65137ASDSCR.B	Active	Production	WSON (DSC) 10	3000 LARGE T&R	Yes	NIPDAU	Level-2-260C-1 YEAR	-40 to 85	PPGC

(1) **Status:** For more details on status, see our [product life cycle](#).

(2) **Material type:** When designated, preproduction parts are prototypes/experimental devices, and are not yet approved or released for full production. Testing and final process, including without limitation quality assurance, reliability performance testing, and/or process qualification, may not yet be complete, and this item is subject to further changes or possible discontinuation. If available for ordering, purchases will be subject to an additional waiver at checkout, and are intended for early internal evaluation purposes only. These items are sold without warranties of any kind.

(3) **RoHS values:** Yes, No, RoHS Exempt. See the [TI RoHS Statement](#) for additional information and value definition.

(4) **Lead finish/Ball material:** Parts may have multiple material finish options. Finish options are separated by a vertical ruled line. Lead finish/Ball material values may wrap to two lines if the finish value exceeds the maximum column width.

(5) **MSL rating/Peak reflow:** The moisture sensitivity level ratings and peak solder (reflow) temperatures. In the event that a part has multiple moisture sensitivity ratings, only the lowest level per JEDEC standards is shown. Refer to the shipping label for the actual reflow temperature that will be used to mount the part to the printed circuit board.

(6) **Part marking:** There may be an additional marking, which relates to the logo, the lot trace code information, or the environmental category of the part.

Multiple part markings will be inside parentheses. Only one part marking contained in parentheses and separated by a "~" will appear on a part. If a line is indented then it is a continuation of the previous line and the two combined represent the entire part marking for that device.

Important Information and Disclaimer:The information provided on this page represents TI's knowledge and belief as of the date that it is provided. TI bases its knowledge and belief on information provided by third parties, and makes no representation or warranty as to the accuracy of such information. Efforts are underway to better integrate information from third parties. TI has taken and continues to take reasonable steps to provide representative and accurate information but may not have conducted destructive testing or chemical analysis on incoming materials and chemicals. TI and TI suppliers consider certain information to be proprietary, and thus CAS numbers and other limited information may not be available for release.

In no event shall TI's liability arising out of such information exceed the total purchase price of the TI part(s) at issue in this document sold by TI to Customer on an annual basis.

TAPE AND REEL INFORMATION

QUADRANT ASSIGNMENTS FOR PIN 1 ORIENTATION IN TAPE

*All dimensions are nominal

Device	Package Type	Package Drawing	Pins	SPQ	Reel Diameter (mm)	Reel Width W1 (mm)	A0 (mm)	B0 (mm)	K0 (mm)	P1 (mm)	W (mm)	Pin1 Quadrant
TPS65137ASDSCR	WSO	DSC	10	3000	330.0	12.4	3.3	3.3	1.1	8.0	12.0	Q2

TAPE AND REEL BOX DIMENSIONS

*All dimensions are nominal

Device	Package Type	Package Drawing	Pins	SPQ	Length (mm)	Width (mm)	Height (mm)
TPS65137ASDSCR	WSON	DSC	10	3000	552.0	346.0	36.0

TUBE

*All dimensions are nominal

Device	Package Name	Package Type	Pins	SPQ	L (mm)	W (mm)	T (μm)	B (mm)
TPS65137ASDSCR	DSC	WSON	10	3000	381	4.83	2286	0
TPS65137ASDSCR.B	DSC	WSON	10	3000	381	4.83	2286	0

GENERIC PACKAGE VIEW

DSC 10

WSON - 0.8 mm max height

PLASTIC SMALL OUTLINE - NO LEAD

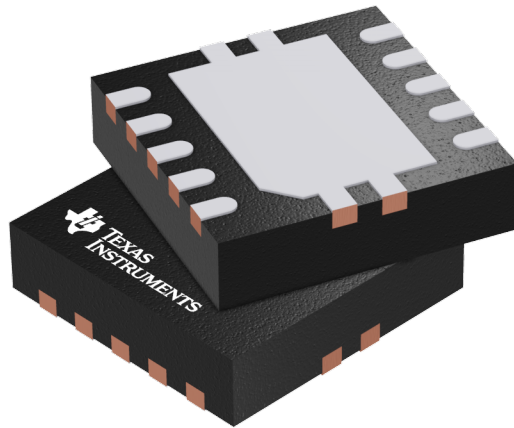

Images above are just a representation of the package family, actual package may vary.
Refer to the product data sheet for package details.

4207383/F

EXAMPLE BOARD LAYOUT

DSC0010J

WSON - 0.8 mm max height

PLASTIC SMALL OUTLINE - NO LEAD



LAND PATTERN EXAMPLE
EXPOSED METAL SHOWN
SCALE:20X



SOLDER MASK DETAILS

4221826/D 08/2018

NOTES: (continued)

4. This package is designed to be soldered to a thermal pad on the board. For more information, see Texas Instruments literature number SLUA271 (www.ti.com/lit/sluea271).
5. Vias are optional depending on application, refer to device data sheet. If any vias are implemented, refer to their locations shown on this view. It is recommended that vias under paste be filled, plugged or tented.

EXAMPLE STENCIL DESIGN

DSC0010J

WSON - 0.8 mm max height

PLASTIC SMALL OUTLINE - NO LEAD

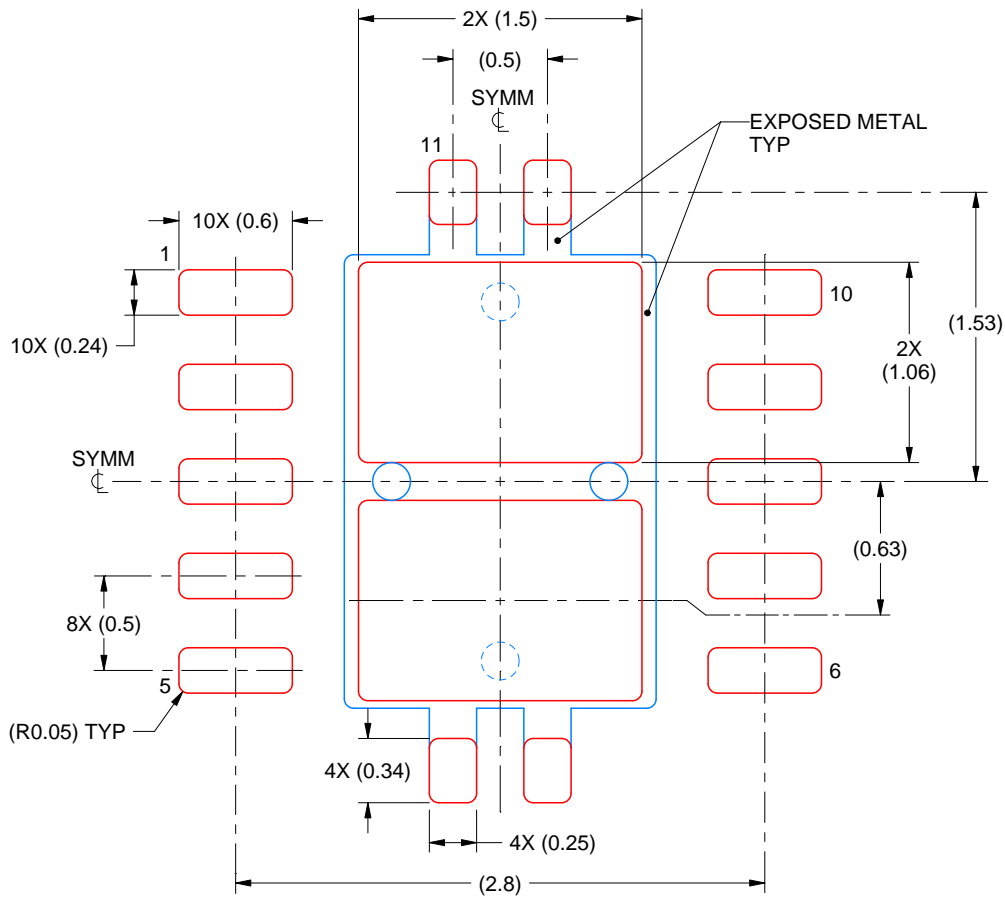

SOLDER PASTE EXAMPLE
BASED ON 0.125 mm THICK STENCIL

EXPOSED PAD 11:
80% PRINTED SOLDER COVERAGE BY AREA
SCALE:25X

4221826/D 08/2018

NOTES: (continued)

6. Laser cutting apertures with trapezoidal walls and rounded corners may offer better paste release. IPC-7525 may have alternate design recommendations.

IMPORTANT NOTICE AND DISCLAIMER

TI PROVIDES TECHNICAL AND RELIABILITY DATA (INCLUDING DATASHEETS), DESIGN RESOURCES (INCLUDING REFERENCE DESIGNS), APPLICATION OR OTHER DESIGN ADVICE, WEB TOOLS, SAFETY INFORMATION, AND OTHER RESOURCES "AS IS" AND WITH ALL FAULTS, AND DISCLAIMS ALL WARRANTIES, EXPRESS AND IMPLIED, INCLUDING WITHOUT LIMITATION ANY IMPLIED WARRANTIES OF MERCHANTABILITY, FITNESS FOR A PARTICULAR PURPOSE OR NON-INFRINGEMENT OF THIRD PARTY INTELLECTUAL PROPERTY RIGHTS.

These resources are intended for skilled developers designing with TI products. You are solely responsible for (1) selecting the appropriate TI products for your application, (2) designing, validating and testing your application, and (3) ensuring your application meets applicable standards, and any other safety, security, regulatory or other requirements.

These resources are subject to change without notice. TI grants you permission to use these resources only for development of an application that uses the TI products described in the resource. Other reproduction and display of these resources is prohibited. No license is granted to any other TI intellectual property right or to any third party intellectual property right. TI disclaims responsibility for, and you fully indemnify TI and its representatives against any claims, damages, costs, losses, and liabilities arising out of your use of these resources.

TI's products are provided subject to [TI's Terms of Sale](#), [TI's General Quality Guidelines](#), or other applicable terms available either on [ti.com](#) or provided in conjunction with such TI products. TI's provision of these resources does not expand or otherwise alter TI's applicable warranties or warranty disclaimers for TI products. Unless TI explicitly designates a product as custom or customer-specified, TI products are standard, catalog, general purpose devices.

TI objects to and rejects any additional or different terms you may propose.

Copyright © 2025, Texas Instruments Incorporated

Last updated 10/2025