

## DUAL-OUTPUT, LOW DROPOUT VOLTAGE REGULATORS WITH INTEGRATED SVS FOR SPLIT VOLTAGE SYSTEMS

 Check for Samples: [TPS70445](#), [TPS70448](#), [TPS70451](#), [TPS70458](#), [TPS70402](#)

### FEATURES

- Dual Output Voltages for Split-Supply Applications
- Independent Enable Functions (See Part Number [TPS703xx](#) for Sequenced Outputs)
- Output Current Range of 1 A on Regulator 1 and 2 A on Regulator 2
- Fast Transient Response
- Voltage Options: 3.3-V/2.5-V, 3.3-V/1.8-V, 3.3-V/1.5-V, 3.3-V/1.2-V, and Dual Adjustable Outputs
- Open Drain Power-On Reset with 120-ms Delay
- Open Drain Power Good for Regulator 1 and Regulator 2
- Ultralow 185 $\mu$ A (typ) Quiescent Current
- 2 $\mu$ A Input Current During Standby
- Low Noise: 78 $\mu$ V<sub>RMS</sub> Without Bypass Capacitor
- Quick Output Capacitor Discharge Feature
- One Manual Reset Input
- 2% Accuracy Over Load and Temperature
- Undervoltage Lockout (UVLO) Feature
- 24-Pin PowerPAD™ TSSOP Package
- Thermal Shutdown Protection

### DESCRIPTION

The TPS704xx family of devices consists of dual-output, low-dropout voltage regulators with integrated SVS (RESET, POR, or power on reset) and power good (PG) functions. These devices are capable of supplying 1 A and 2 A by regulator 1 and regulator 2 respectively. Quiescent current is typically 185  $\mu$ A at full load. Differentiated features, such as accuracy, fast transient response, SVS supervisory circuit (power on reset), manual reset input, and independent enable functions provide a complete system solution.

PWP PACKAGE  
(TOP VIEW)

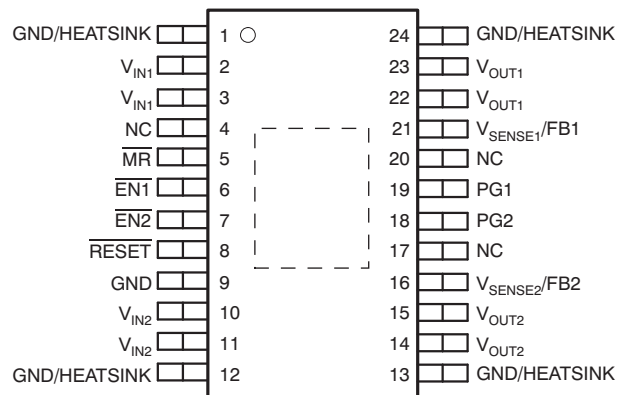

NC = No internal connection

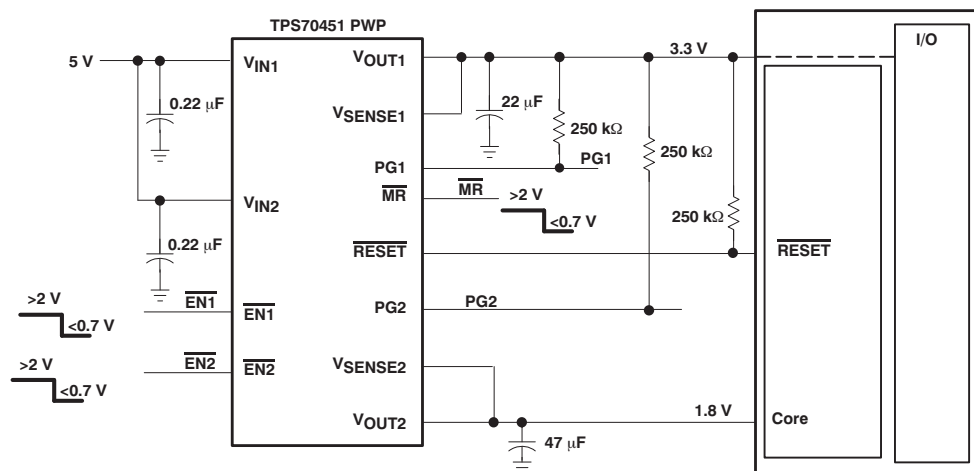

Please be aware that an important notice concerning availability, standard warranty, and use in critical applications of Texas Instruments semiconductor products and disclaimers thereto appears at the end of this data sheet.

PowerPAD is a trademark of Texas Instruments.  
All other trademarks are the property of their respective owners.

The TPS704xx family of voltage regulators offers very low dropout voltage and dual outputs. These devices have extremely low noise output performance without using any added filter bypass capacitors and are designed to have a fast transient response and be stable with 47- $\mu$ F low ESR capacitors.

These devices have fixed 3.3-V/2.5-V, 3.3-V/1.8-V, 3.3-V/1.5-V, 3.3-V/1.2-V, and adjustable voltage options. Regulator 1 can support up to 1 A, and regulator 2 can support up to 2 A. Separate voltage inputs allow the designer to configure the source power.

Because the PMOS device behaves as a low-value resistor, the dropout voltage is very low (typically 160 mV on regulator 1) and is directly proportional to the output current. Additionally, since the PMOS pass element is a voltage-driven device, the quiescent current is very low and independent of output loading (maximum of 250  $\mu$ A over the full range of output current and full range of temperature). This LDO family also features a sleep mode; applying a high signal to EN1 or EN2 (enable) shuts down regulator 1 or regulator 2, respectively. When a high signal is applied to both EN1 and EN2, both regulators enter sleep mode, thereby reducing the input current to 2  $\mu$ A at  $T_J = +25^\circ\text{C}$ .

For each regulator, there is an internal discharge transistor to discharge the output capacitor when the regulator is turned off (disabled).

The PG1 pin reports the voltage condition at  $V_{OUT1}$ . The PG1 pin can be used to implement a SVS (RESET, POR, or power on reset) for the circuitry supplied by regulator 1. The PG2 pin reports the voltage conditions at  $V_{OUT2}$ . The PG2 pin can be used to implement a SVS (power on reset) for the circuitry supplied by regulator 2.

The TPS704xx features a RESET (SVS, POR, or power on reset). RESET is an active low, open drain output and requires a pull-up resistor for normal operation. When pulled up, RESET goes into a high impedance state (that is, logic high) after a 120-ms delay when both of the following conditions are met. First,  $V_{IN1}$  must be above the undervoltage condition. Second, the manual reset (MR) pin must be in a high impedance state. To monitor  $V_{OUT1}$ , the PG1 output pin can be connected to MR. To monitor  $V_{OUT2}$ , the PG2 output pin can be connected to MR. RESET can be used to drive power on reset or a low-battery indicator. If RESET is not used, it can be left floating.

Internal bias voltages are powered by  $V_{IN1}$  and require 2.7 V for full functionality. Each regulator input has an undervoltage lockout circuit that prevents each output from turning on until the respective input reaches 2.5 V.



This integrated circuit can be damaged by ESD. Texas Instruments recommends that all integrated circuits be handled with appropriate precautions. Failure to observe proper handling and installation procedures can cause damage.

ESD damage can range from subtle performance degradation to complete device failure. Precision integrated circuits may be more susceptible to damage because very small parametric changes could cause the device not to meet its published specifications.

### ORDERING INFORMATION<sup>(1)</sup>

PRODUCT	VOLTAGE (V) <sup>(2)</sup>		PACKAGE-LEAD (DESIGNATOR)	SPECIFIED TEMPERATURE RANGE (T <sub>J</sub> )	ORDERING NUMBER	TRANSPORT MEDIA, QUANTITY
	V <sub>OUT1</sub>	V <sub>OUT2</sub>				
TPS70402	Adjustable	Adjustable	HTSSOP-24 (PWP)	–40°C to +125°C	TPS70402PWP	Tube, 60
					TPS70402PWPR	Tape and Reel, 2000
TPS70445	3.3 V	1.2 V	HTSSOP-24 (PWP)	–40°C to +125°C	TPS70445PWP	Tube, 60
					TPS70445PWPR	Tape and Reel, 2000
TPS70448	3.3 V	1.5 V	HTSSOP-24 (PWP)	–40°C to +125°C	TPS70448PWP	Tube, 60
					TPS70448PWPR	Tape and Reel, 2000
TPS70451	3.3 V	1.8 V	HTSSOP-24 (PWP)	–40°C to +125°C	TPS70451PWP	Tube, 60
					TPS70451PWPR	Tape and Reel, 2000
TPS70458	3.3 V	2.5 V	HTSSOP-24 (PWP)	–40°C to +125°C	TPS70458PWP	Tube, 60
					TPS70458PWPR	Tape and Reel, 2000

(1) For the most current package and ordering information, see the Package Option Addendum at the end of this document, or visit the device product folder at [ti.com](http://ti.com).

(2) For fixed 1.20 V operation, tie FB to OUT.

### ABSOLUTE MAXIMUM RATINGS<sup>(1)</sup>

Over operating free-air temperature range (unless otherwise noted).

	TPS704xx	UNIT
Input voltage range: V <sub>IN1</sub> , V <sub>IN2</sub> <sup>(2)</sup>	–0.3 to +7	V
Voltage range at $\overline{EN1}$ , $\overline{EN2}$	–0.3 to +7	V
Output voltage range (V <sub>OUT1</sub> , V <sub>SENSE1</sub> )	5.5	V
Output voltage range (V <sub>OUT2</sub> , V <sub>SENSE2</sub> )	5.5	V
Maximum RESET, PG1, PG2 voltage	7	V
Maximum MR voltage	V <sub>IN1</sub>	V
Peak output current	Internally limited	—
Continuous total power dissipation	See <a href="#">Dissipation Ratings Table</a>	—
Operating virtual junction temperature range, T <sub>J</sub>	–40 to +150	°C
Storage temperature range, T <sub>stg</sub>	–65 to +150	°C
ESD rating, HBM	2	kV

(1) Stresses beyond those listed under absolute maximum ratings may cause permanent damage to the device. These are stress ratings only, and functional operation of the device at these or any other conditions beyond those indicated under recommended operating conditions is not implied. Exposure to absolute-maximum-rated conditions for extended periods may affect device reliability.

(2) All voltages are tied to network ground.

## DISSIPATION RATINGS

PACKAGE	AIR FLOW (CFM)	T <sub>A</sub> ≤ +25°C	DERATING FACTOR	T <sub>A</sub> = +70°C	T <sub>A</sub> = +85°C
PWP <sup>(1)</sup>	0	3.067W	30.67mW/°C	1.687W	1.227W
	250	4.115W	41.15mW/°C	2.265W	1.646W

(1) This parameter is measured with the recommended copper heat sink pattern on a 4-layer PCB, 1 oz. copper on a 4-in by 4-in ground layer. For more information, refer to TI technical brief [SLMA002](#).

## RECOMMENDED OPERATING CONDITIONS

Over operating temperature range (unless otherwise noted).

	MIN	MAX	UNIT
Input voltage, V <sub>I</sub> <sup>(1)</sup> (regulator 1 and 2)	2.7	6	V
Output current, I <sub>O</sub> (regulator 1)	0	1	A
Output current, I <sub>O</sub> (regulator 2)	0	2	A
Output voltage range (for adjustable option)	1.22	5.5	V
Operating virtual junction temperature, T <sub>J</sub>	-40	+125	°C

(1) To calculate the minimum input voltage for maximum output current, use the following equation:  $V_{I(\min)} = V_{O(\max)} + V_{DO(\max \text{ load})}$ .

## ELECTRICAL CHARACTERISTICS

Over recommended operating junction temperature range ( $T_J = -40^\circ\text{C}$  to  $+125^\circ\text{C}$ ),  $V_{IN1}$  or  $V_{IN2} = V_{OUT(nom)} + 1\text{ V}$ ,  $I_O = 1\text{ mA}$ ,  $\overline{EN} = 0\text{ V}$ ,  $C_{OUT1} = 22\text{ }\mu\text{F}$ , and  $C_{OUT2} = 47\text{ }\mu\text{F}$  (unless otherwise noted).

PARAMETER		TEST CONDITIONS		MIN	TYP	MAX	UNIT
$V_O$	Reference voltage	$2.7\text{ V} < V_{IN} < 6\text{ V}$ , $T_J = +25^\circ\text{C}$	FB connected to $V_O$		1.22		V
		$2.7\text{ V} < V_{IN} < 6\text{ V}$ ,	FB connected to $V_O$	1.196		1.244	
	1.2 V Output ( $V_{OUT2}$ )	$2.7\text{ V} < V_{IN} < 6\text{ V}$ ,	$T_J = +25^\circ\text{C}$		1.2		
		$2.7\text{ V} < V_{IN} < 6\text{ V}$ ,		1.176		1.224	
	1.5 V Output ( $V_{OUT2}$ )	$2.7\text{ V} < V_{IN} < 6\text{ V}$ ,	$T_J = +25^\circ\text{C}$		1.5		
		$2.7\text{ V} < V_{IN} < 6\text{ V}$ ,		1.47		1.53	
	1.8 V Output ( $V_{OUT2}$ )	$2.8\text{ V} < V_{IN} < 6\text{ V}$ ,	$T_J = +25^\circ\text{C}$		1.8		
		$2.8\text{ V} < V_{IN} < 6\text{ V}$ ,		1.764		1.836	
	2.5 V Output ( $V_{OUT2}$ )	$3.5\text{ V} < V_{IN} < 6\text{ V}$ ,	$T_J = +25^\circ\text{C}$		2.5		
		$3.5\text{ V} < V_{IN} < 6\text{ V}$ ,		2.45		2.55	
3.3 V Output ( $V_{OUT2}$ )	$4.3\text{ V} < V_{IN} < 6\text{ V}$ ,	$T_J = +25^\circ\text{C}$		3.3			
	$4.3\text{ V} < V_{IN} < 6\text{ V}$ ,		3.234		3.366		
Quiescent current (GND current) for regulator 1 and regulator 2, $\overline{EN1} = \overline{EN2} = 0\text{ V}^{(1)}$		See <sup>(2)</sup>	$T_J = +25^\circ\text{C}$		185		$\mu\text{A}$
		See <sup>(2)</sup>				250	
Output voltage line regulation ( $\Delta V_O/V_O$ ) for regulator 1 and regulator 2 <sup>(3)</sup>		$V_O + 1\text{ V} < V_{IN} \leq 6\text{ V}$ ,	$T_J = +25^\circ\text{C}^{(1)}$		0.01		%V
		$V_O + 1\text{ V} < V_{IN} \leq 6\text{ V}$	<sup>(1)</sup>			0.1	
Load regulation for $V_{OUT1}$ and $V_{OUT2}$		$T_J = +25^\circ\text{C}$			1		mV
$V_n$	Output noise voltage (TPS70451)	Regulator 1	BW = 300 Hz to 50 kHz, $C_O = 33\text{ }\mu\text{F}$ , $T_J = +25^\circ\text{C}$		79		$\mu\text{V}_{\text{RMS}}$
		Regulator 2			77		
Output current limit		Regulator 1	$V_{OUT} = 0\text{ V}$		1.75	2.2	A
		Regulator 2			3.8	4.5	
Thermal shutdown junction temperature					+150		$^\circ\text{C}$
$I_i$	Standby current (standby)	Regulator 1	$\overline{EN1} = V_{IN}$ , $\overline{EN2} = V_{IN}$	$T_J = +25^\circ\text{C}$	1	2	$\mu\text{A}$
		Regulator 2	$\overline{EN1} = V_{IN}$ , $\overline{EN2} = V_{IN}$			10	
PSRR	Power-supply ripple rejection (TPS70451)	Regulator 1	$f = 1\text{ kHz}$	$T_J = +25^\circ\text{C}^{(1)}$	65		dB
		Regulator 2	$f = 1\text{ kHz}$	$T_J = +25^\circ\text{C}^{(1)}$	60		
<b>RESET Terminal</b>							
Minimum input voltage for valid $\overline{\text{RESET}}$		$I_{\text{RESET}} = 300\text{ }\mu\text{A}$ ,	$V_{(\text{RESET})} \leq 0.8\text{ V}$		1.0	1.3	V
$t_{(\text{RESET})}$		$\overline{\text{RESET}}$ pulse duration			80	120	160
Output low voltage		$V_{IN} = 3.5\text{ V}$ ,	$I_{(\text{RESET})} = 1\text{ mA}$		0.15	0.4	V
Leakage current		$V_{(\text{RESET})} = 6\text{ V}$				1	$\mu\text{A}$

(1) Minimum input operating voltage is  $2.7\text{ V}$  or  $V_{O(\text{typ})} + 1\text{ V}$ , whichever is greater. Maximum input voltage =  $6\text{ V}$ , minimum output current =  $1\text{ mA}$ .

(2)  $I_O = 1\text{ mA}$  to  $1\text{ A}$  for Regulator 1 and  $1\text{ mA}$  to  $2\text{ A}$  for Regulator 2.

(3) If  $V_O < 1.8\text{ V}$  then  $V_{\text{Imax}} = 6\text{ V}$ ,  $V_{\text{Imin}} = 2.7\text{ V}$ :  
 Line regulation (mV) = (%/V)  $\times V_O \times \frac{(V_{\text{Imax}} - 2.7)}{100} \times 1000$   
 If  $V_O > 2.5\text{ V}$  then  $V_{\text{Imax}} = 6\text{ V}$ ,  $V_{\text{Imin}} = V_O + 1\text{ V}$ :  
 Line regulation (mV) = (%/V)  $\times V_O \times \frac{[V_{\text{Imax}} - (V_O + 1)]}{100} \times 1000$

## ELECTRICAL CHARACTERISTICS (continued)

Over recommended operating junction temperature range ( $T_J = -40^\circ\text{C}$  to  $+125^\circ\text{C}$ ),  $V_{IN1}$  or  $V_{IN2} = V_{OUT(nom)} + 1\text{ V}$ ,  
 $I_O = 1\text{ mA}$ ,  
 $\overline{EN} = 0\text{ V}$ ,  $C_{OUT1} = 22\text{ }\mu\text{F}$ , and  $C_{OUT2} = 47\text{ }\mu\text{F}$  (unless otherwise noted).

PARAMETER	TEST CONDITIONS	MIN	TYP	MAX	UNIT
<b><math>V_{IN1}/V_{IN2}</math> Terminal</b>					
UVLO threshold		2.4		2.65	V
UVLO hysteresis			110		mV
<b>PG1/PG2 Terminal</b>					
Minimum input voltage for valid PGx	$I_{(PGx)} = 300\text{ }\mu\text{A}$ , $V_{(PGx)} \leq 0.8\text{ V}$		1.0	1.3	V
Trip threshold voltage	$V_O$ decreasing	92	95	98	% $V_{OUT}$
Hysteresis voltage	Measured at $V_O$		0.5		% $V_{OUT}$
$t_{r(PGx)}$	Rising edge deglitch		30		$\mu\text{s}$
Output low voltage	$V_{IN} = 2.7\text{ V}$ , $I_{(PGx)} = 1\text{ mA}$		0.15	0.4	V
Leakage current	$V_{(PGx)} = 6\text{ V}$			1	$\mu\text{A}$
<b>EN1/EN2 Terminal</b>					
High-level $\overline{ENx}$ input voltage		2			V
Low-level $\overline{ENx}$ input voltage				0.7	V
Input current ( $\overline{ENx}$ )		-1		1	$\mu\text{A}$
<b>MR Terminal</b>					
High-level input voltage		2			V
Low-level input voltage				0.7	V
Pull-up current source			6		$\mu\text{A}$
<b><math>V_{OUT1}</math> Terminal</b>					
Dropout voltage <sup>(4)</sup>	$I_O = 1\text{ A}$ , $V_{IN1} = 3.2\text{ V}$ $T_J = +25^\circ\text{C}$		160		mV
	$I_O = 1\text{ A}$ , $V_{IN1} = 3.2\text{ V}$			250	
Peak output current	2 ms pulse width		1.2		A
Discharge transistor current	$V_{OUT1} = 1.5\text{ V}$		7.5		mA
<b><math>V_{OUT2}</math> Terminal</b>					
Peak output current	2 ms pulse width		3		A
Discharge transistor current	$V_{OUT2} = 1.5\text{ V}$		7.5		mA
<b>FB Terminal</b>					
Input current: TPS70402	FB = 1.8 V			1	$\mu\text{A}$

(4) Input voltage ( $V_{IN1}$  or  $V_{IN2}$ ) =  $V_{O(typ)} - 100\text{ mV}$ . For 1.5-V, 1.8-V, and 2.5-V regulators, the dropout voltage is limited by input voltage range. The 3.3-V regulator input is set to 3.2 V to perform this test.

## DEVICE INFORMATION

### Fixed Voltage Version

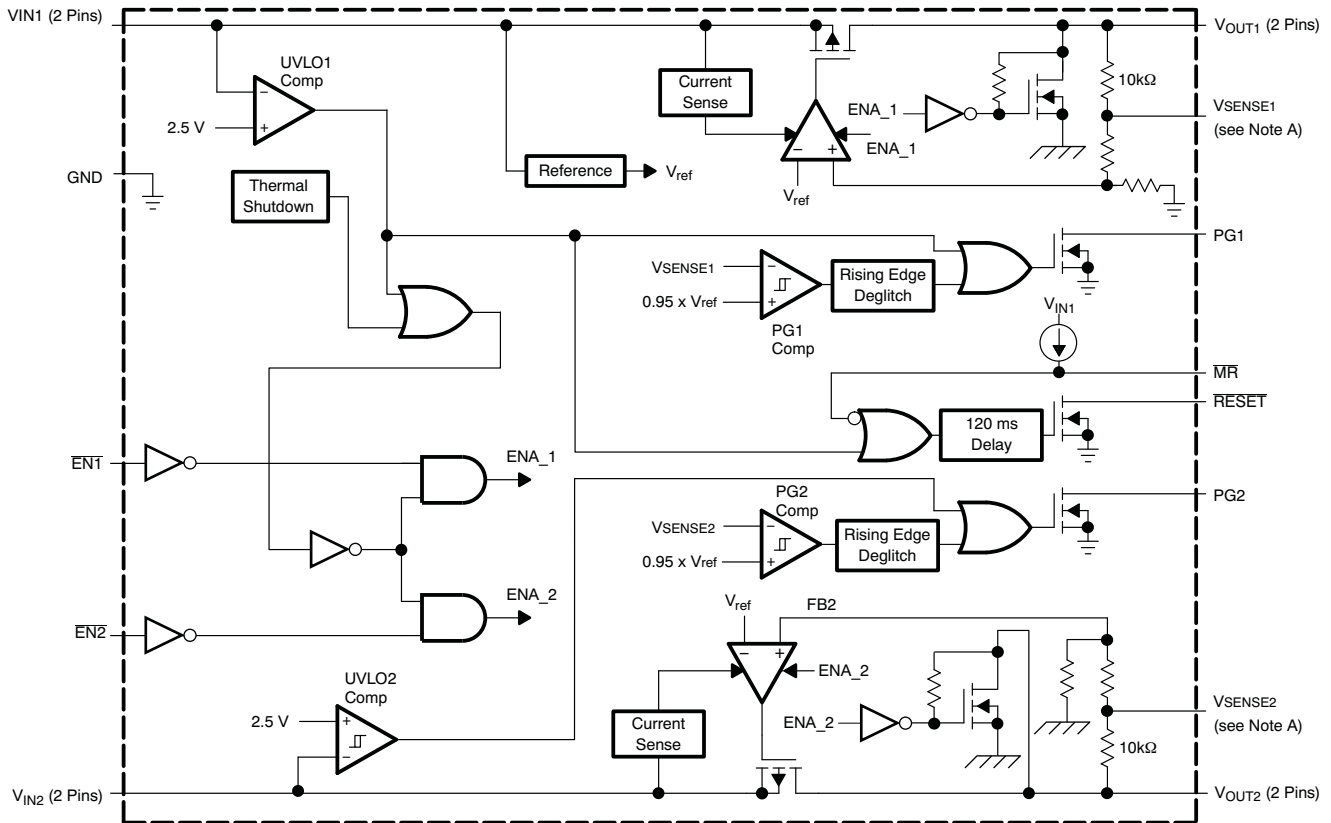

- A. For most applications,  $V_{SENSE1}$  and  $V_{SENSE2}$  should be externally connected to  $V_{OUT1}$  and  $V_{OUT2}$ , respectively, as close as possible to the device. For other implementations, refer to SENSE terminal connection discussion in the [Application Information](#) section.

### Adjustable Voltage Version

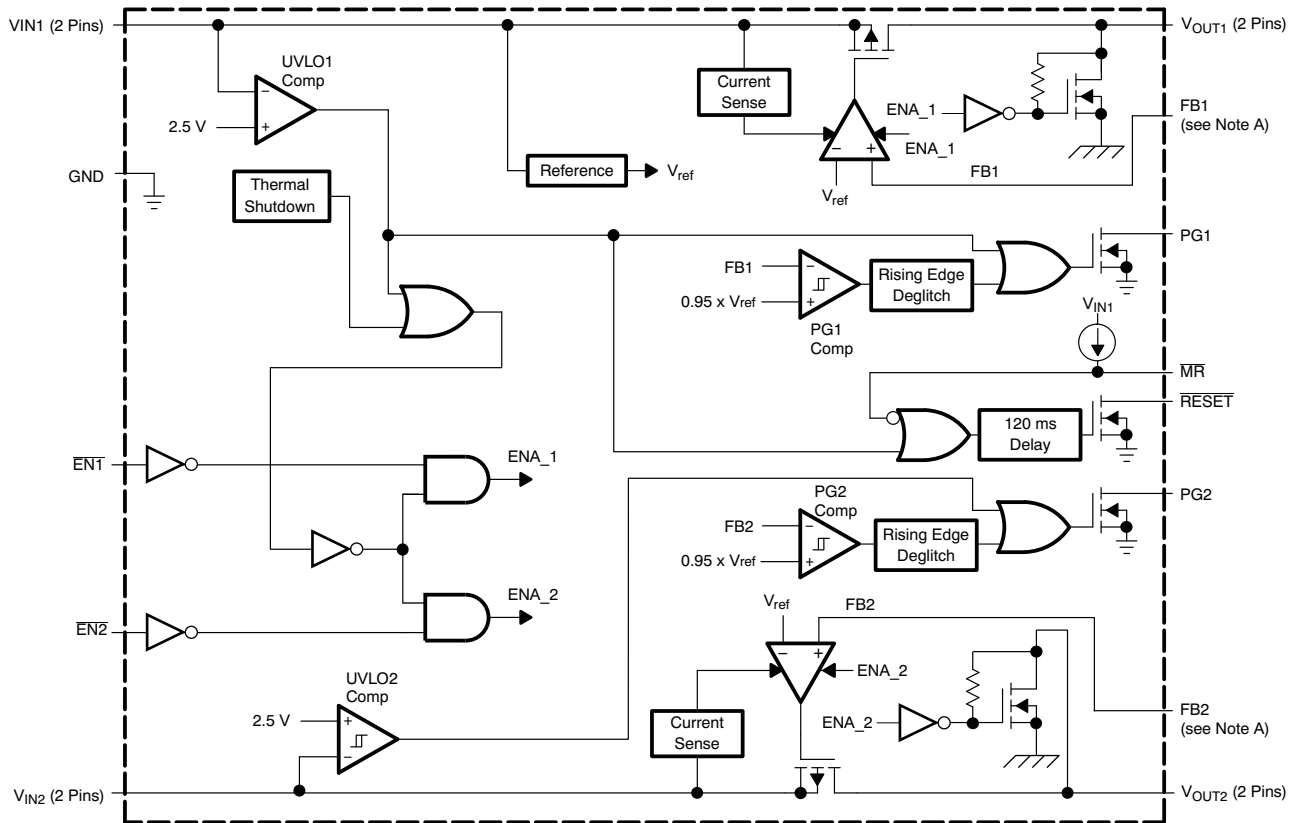

- A. For most applications, FB1 and FB2 should be externally connected to resistor dividers as close as possible to the device. For other implementations, refer to FB terminals connection discussion in the [Application Information](#) section.



### RESET Timing Diagram

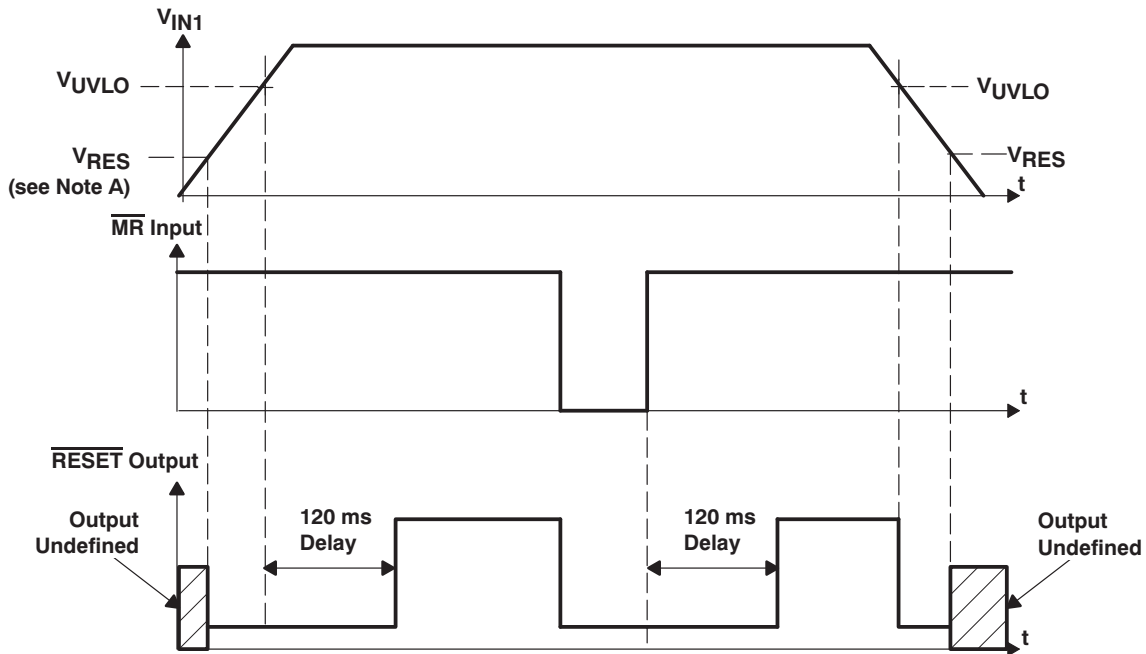

NOTE A:  $V_{RES}$  is the minimum input voltage for a valid  $\overline{RESET}$ . The symbol  $V_{RES}$  is not currently listed within EIA or JEDEC standards for semiconductor symbology.

### PG1 Timing Diagram

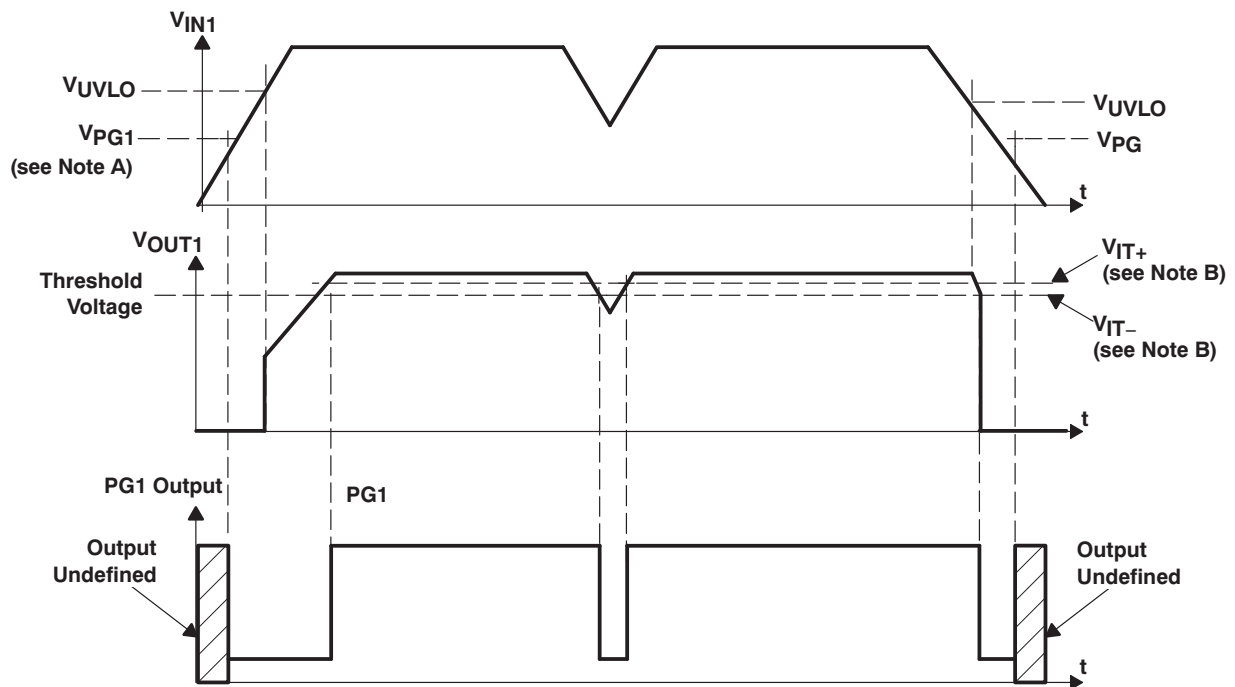

NOTES A:  $V_{PG1}$  is the minimum input voltage for a valid PG. The symbol  $V_{PG1}$  is not currently listed within EIA or JEDEC standards for semiconductor symbology.

B:  $V_{IT-}$  trip voltage is typically 5% lower than the output voltage ( $95\%V_O$ ).  $V_{IT-}$  to  $V_{IT+}$  is the hysteresis voltage.

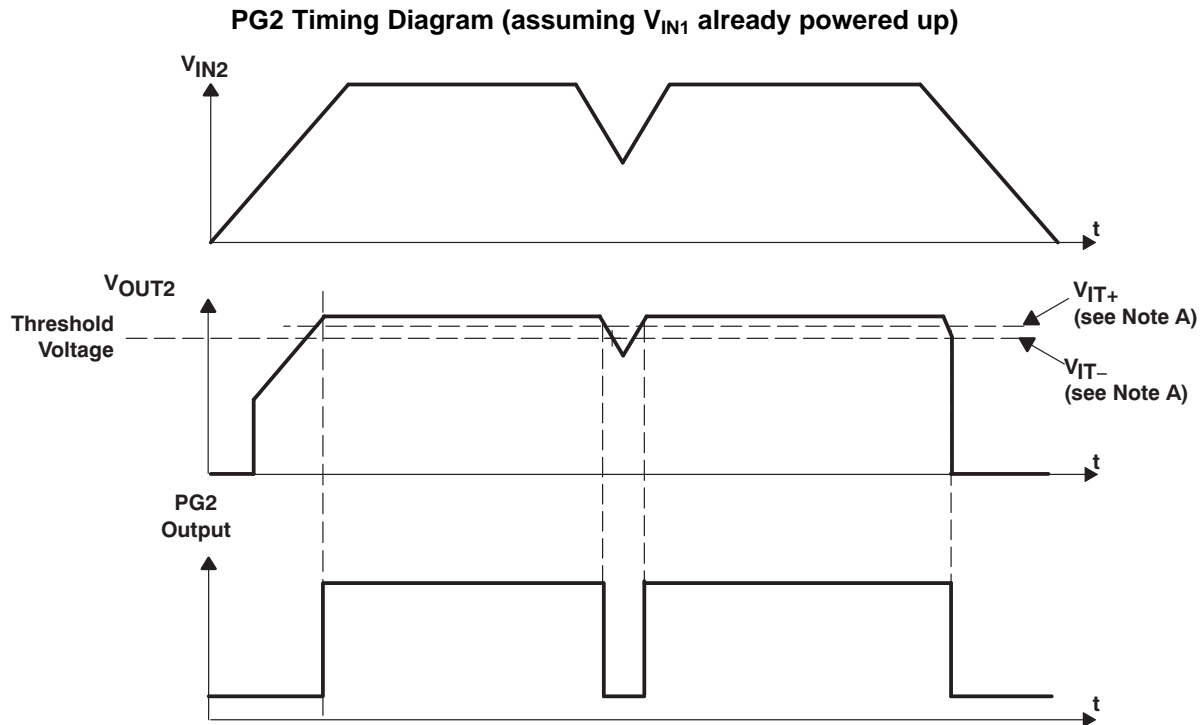

NOTE A:  $V_{IT-}$  trip voltage is typically 5% lower than the output voltage ( $95\%V_O$ ).  $V_{IT-}$  to  $V_{IT+}$  is the hysteresis voltage.

### TERMINAL FUNCTIONS

TERMINAL		I/O	DESCRIPTION
NAME	NO.		
$\overline{EN1}$	6	I	Active low enable for $V_{OUT1}$
$\overline{EN2}$	7	I	Active low enable for $V_{OUT2}$
GND	9	—	Ground
GND/HEATSINK	1, 12, 13, 24	—	Ground/heatsink
$\overline{MR}$	5	I	Manual reset input, active low, pulled up internally
NC	4, 17, 20	—	No connection
PG1	19	O	Open drain output, low when $V_{OUT1}$ voltage is less than 95% of the nominal regulated voltage
PG2	18	O	Open drain output, low when $V_{OUT2}$ voltage is less than 95% of the nominal regulated voltage
$\overline{RESET}$	8	O	Open drain output, SVS (power-on reset) signal, active low
$V_{IN1}$	2, 3	I	Input voltage of regulator 1
$V_{IN2}$	10, 11	I	Input voltage of regulator 2
$V_{OUT1}$	22, 23	O	Output voltage of regulator 1
$V_{OUT2}$	14, 15	O	Output voltage of regulator 2
$V_{SENSE1}/FB1$	21	I	Regulator 1 output voltage sense/regulator 1 feedback for adjustable
$V_{SENSE2}/FB2$	16	I	Regulator 2 output voltage sense/regulator 2 feedback for adjustable

## Detailed Description

The TPS704xx low dropout regulator family provides dual regulated output voltages with independent enable functions. These devices provide fast transient response and high accuracy with small output capacitors, while drawing low quiescent current. Other features are integrated SVS (power-on reset,  $\overline{\text{RESET}}$ ) and power good (PG1, PG2) that monitor output voltages and provide logic output to the system. These differentiated features provide a complete power solution.

The TPS704xx, unlike many other LDOs, features very low quiescent current that remains virtually constant even with varying loads. Conventional LDO regulators use a PNP pass element, the base current of which is directly proportional to the load current through the regulator ( $I_B = I_C/\beta$ ). The TPS704xx uses a PMOS transistor to pass current; because the gate of the PMOS is voltage-driven, operating current is low and stable over the full load range.

## Pin Functions

### Enable ( $\overline{\text{EN1}}$ , $\overline{\text{EN2}}$ )

The  $\overline{\text{EN}}$  terminals are inputs that enable or shut down each respective regulator. If  $\overline{\text{EN}}$  is at a voltage high signal, the respective regulator is in shutdown mode. When  $\overline{\text{EN}}$  goes to voltage low, the respective regulator is enabled.

### Power-Good (PG1, PG2)

The PG terminals are open drain, active high output terminals that indicate the status of each respective regulator. When  $V_{\text{OUT1}}$  reaches 95% of its regulated voltage, PG1 goes to a high impedance state. When  $V_{\text{OUT2}}$  reaches 95% of its regulated voltage, PG2 goes to a high impedance state. Each PG goes to a low impedance state when its respective output voltage is pulled below 95% (that is, goes to an overload condition) of its regulated voltage. The open drain outputs of the PG terminals require a pull-up resistor.

### Manual Reset Pin

$\overline{\text{MR}}$  is an active low input terminal used to trigger a reset condition. When  $\overline{\text{MR}}$  is pulled to logic low, a POR ( $\overline{\text{RESET}}$ ) occurs. The terminal has a 6- $\mu\text{A}$  pull-up current to  $V_{\text{IN1}}$ ; however, it is recommended that the pin be pulled high to  $V_{\text{IN1}}$  when it is not used.

### Sense ( $V_{\text{SENSE1}}$ , $V_{\text{SENSE2}}$ )

The sense terminals of fixed-output options must be connected to the regulator outputs, and the connection should be as short as possible. Internally, the sense terminal connects to high-impedance, wide-bandwidth amplifiers through a resistor-divider network and noise pickup feeds through to the regulator output. It is essential to route the sense connection in such a way as to minimize or avoid noise pickup. Adding RC networks between sense terminals and  $V_{\text{OUT}}$  terminals to filter noise is not recommended because these networks can cause the regulators to oscillate.

## FB1 and FB2

FB1 and FB2 are input terminals used for adjustable-output devices and must be connected to the external feedback resistor divider. FB1 and FB2 connections should be as short as possible. It is essential to route them in such a way as to minimize or avoid noise pickup. Adding RC networks between FB terminals and  $V_{OUT}$  terminals to filter noise is not recommended because these networks can cause the regulators to oscillate.

## RESET Indicator

$\overline{RESET}$  is an active low, open drain output and requires a pullup resistor for normal operation. When pulled up,  $\overline{RESET}$  goes into a high impedance state (that is, logic high) after a 120-ms delay when both of the following conditions are met. First,  $V_{IN1}$  must be above the undervoltage condition. Second, the manual reset ( $\overline{MR}$ ) pin must be in a high impedance state. To monitor  $V_{OUT1}$ , the PG1 output pin can be connected to  $\overline{MR}$ . To monitor  $V_{OUT2}$ , the PG2 output pin can be connected to  $\overline{MR}$ . If  $\overline{RESET}$  is not used, it can be left floating.

## $V_{IN1}$ and $V_{IN2}$

$V_{IN1}$  and  $V_{IN2}$  are inputs to each regulator. **Internal bias voltages are powered by  $V_{IN1}$ .**

## $V_{OUT1}$ and $V_{OUT2}$

$V_{OUT1}$  and  $V_{OUT2}$  are output terminals of each regulator.

## TYPICAL CHARACTERISTICS

Table of Graphs

			FIGURE
$V_O$	Output voltage	vs Output current	Figure 1 and Figure 2
		vs Junction temperature	Figure 3 to Figure 4
	Ground current	vs Junction temperature	Figure 5
PSRR	Power-supply rejection ratio	vs Frequency	Figure 6 to Figure 9
	Output spectral noise density	vs Frequency	Figure 10 to Figure 13
$Z_O$	Output impedance	vs Frequency	Figure 14 to Figure 17
	Dropout voltage	vs Temperature	Figure 18 and Figure 19
		vs Input voltage	Figure 20 and Figure 21
	Load transient response		Figure 22 and Figure 23
	Line transient response ( $V_{OUT1}$ )		Figure 24
	Line transient response ( $V_{OUT2}$ )		Figure 25
$V_O$	Output voltage	vs Time (start-up)	Figure 26 and Figure 27
		Equivalent series resistance (ESR)	Figure 29 to Figure 32

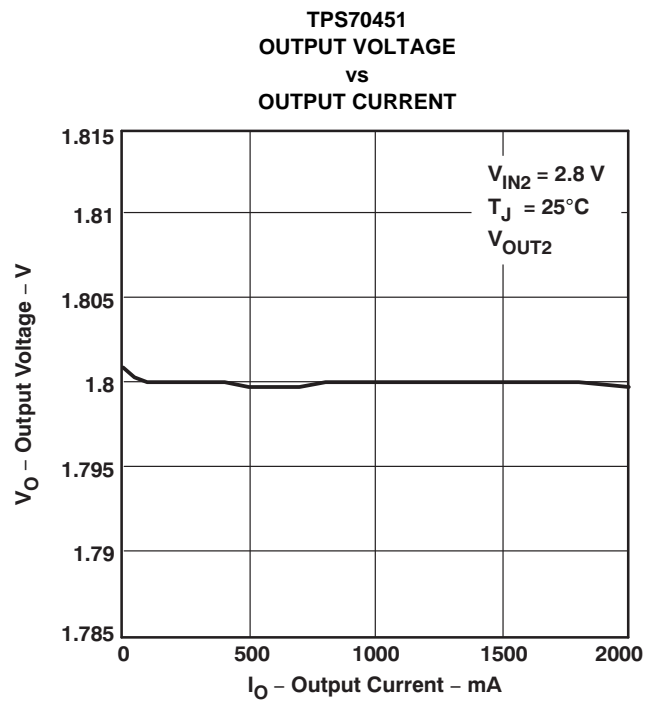
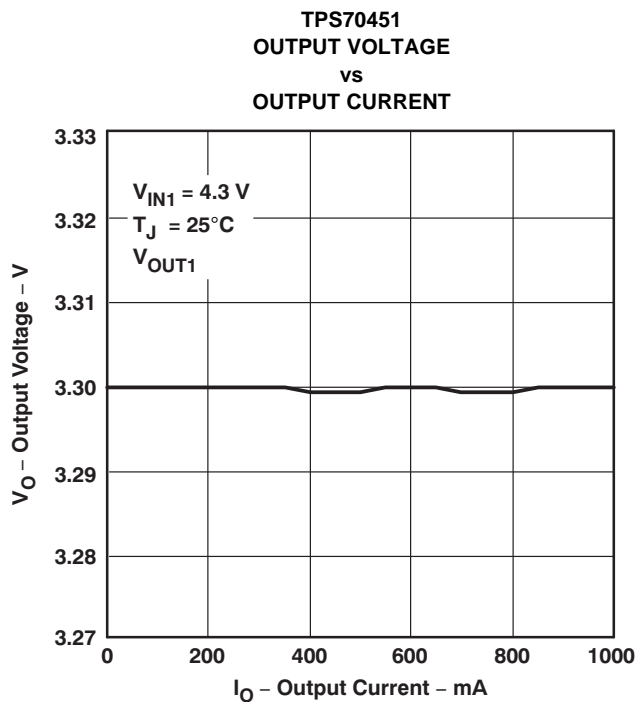

TYPICAL CHARACTERISTICS (continued)

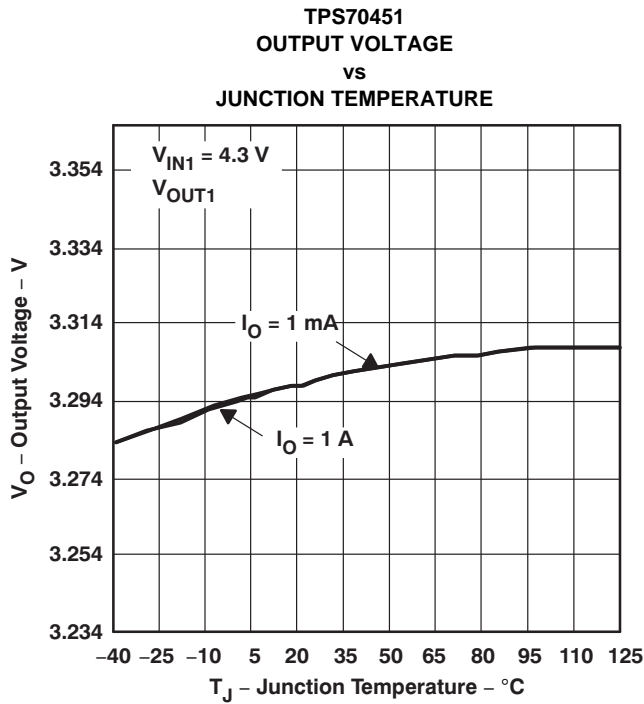

Figure 3.

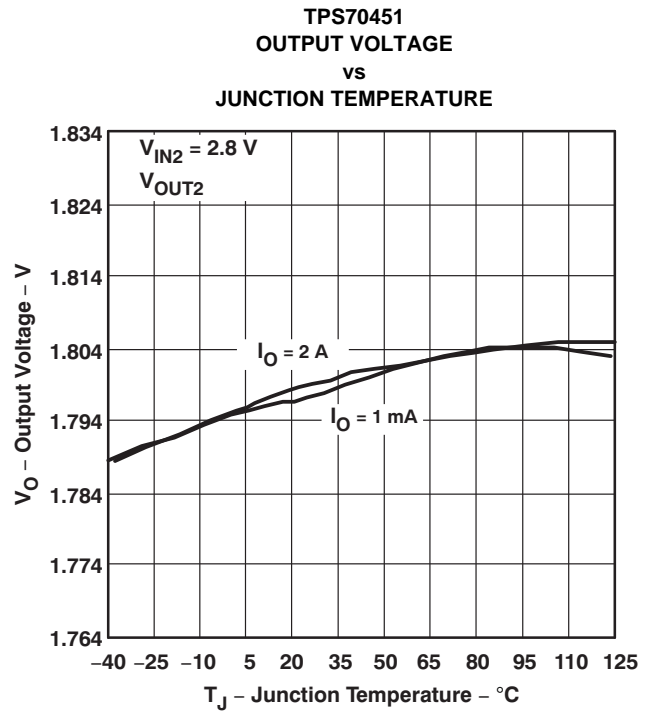

Figure 4.

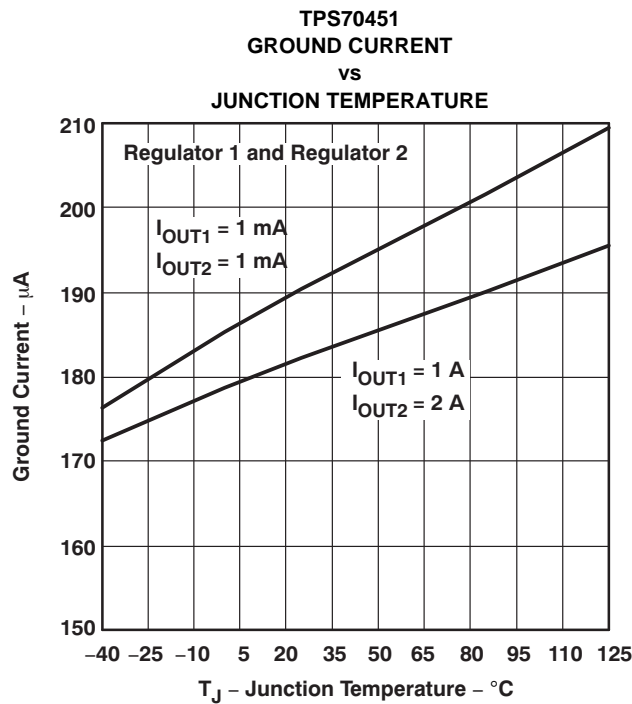

Figure 5.

TYPICAL CHARACTERISTICS (continued)

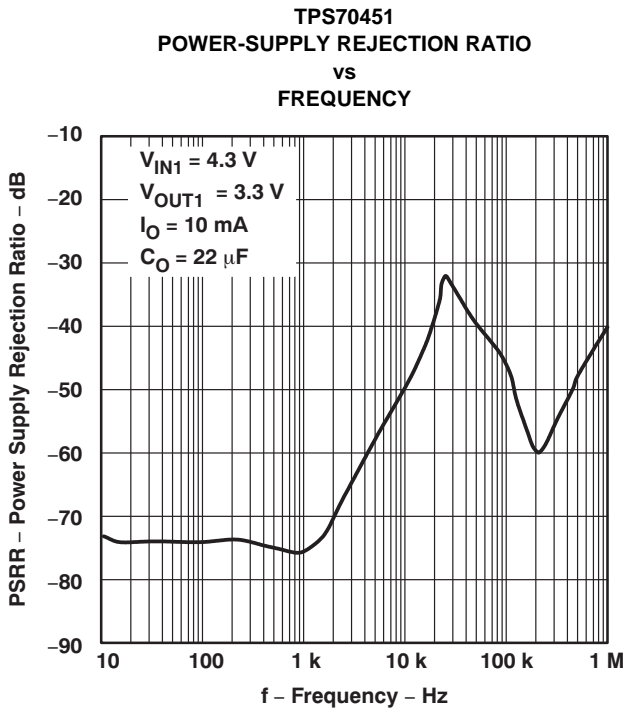

Figure 6.

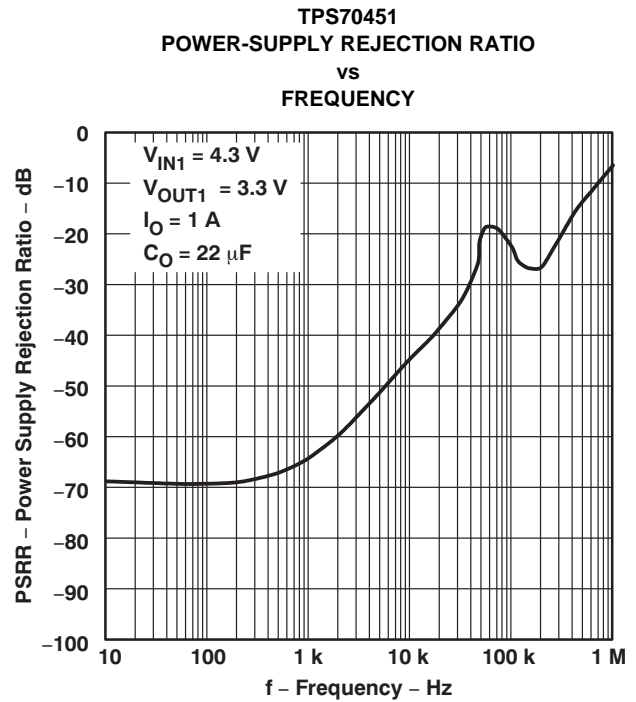

Figure 7.

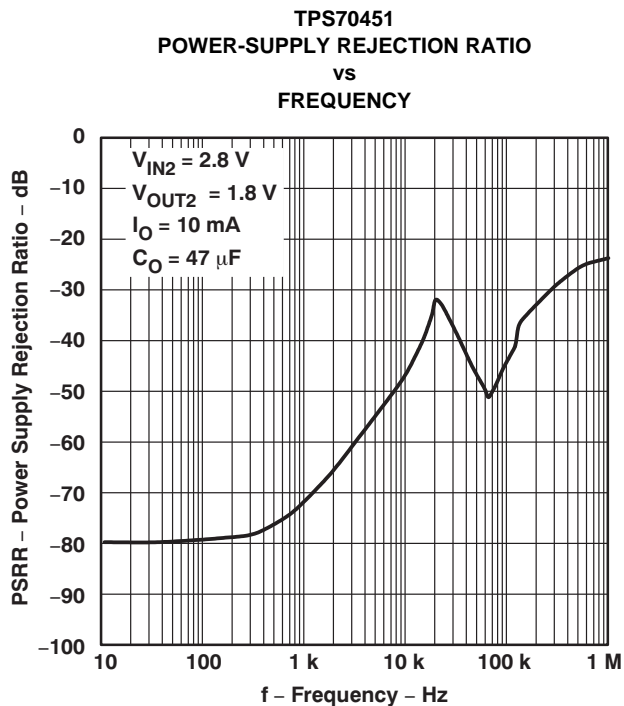

Figure 8.

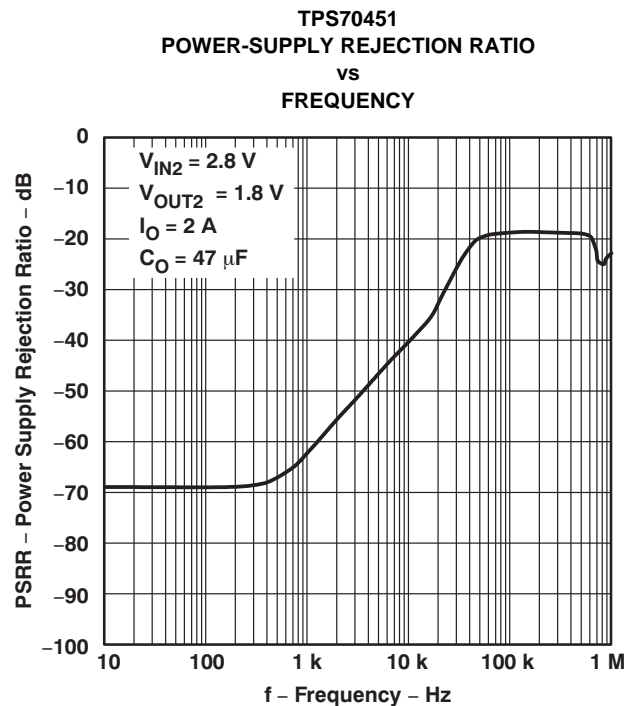

Figure 9.

TYPICAL CHARACTERISTICS (continued)

OUTPUT SPECTRAL NOISE DENSITY  
 vs  
 FREQUENCY

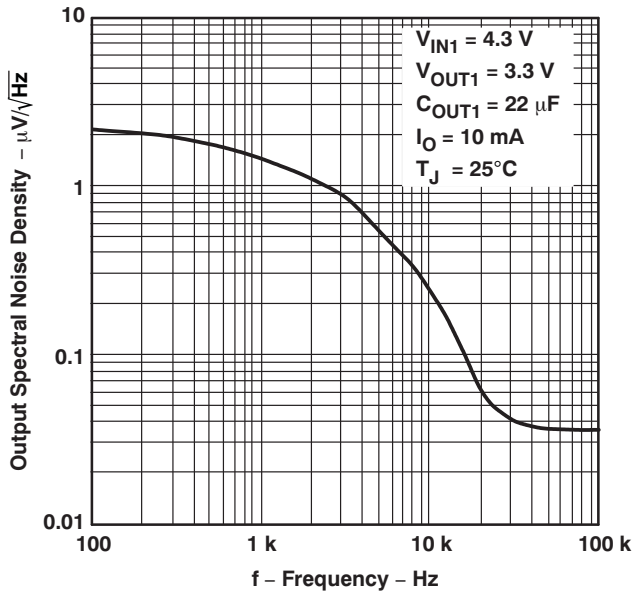

Figure 10.

OUTPUT SPECTRAL NOISE DENSITY  
 vs  
 FREQUENCY

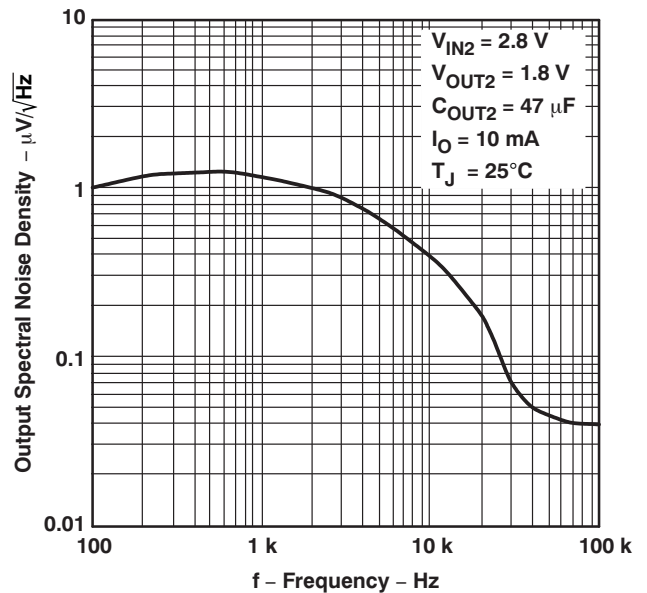

Figure 11.

OUTPUT SPECTRAL NOISE DENSITY  
 vs  
 FREQUENCY

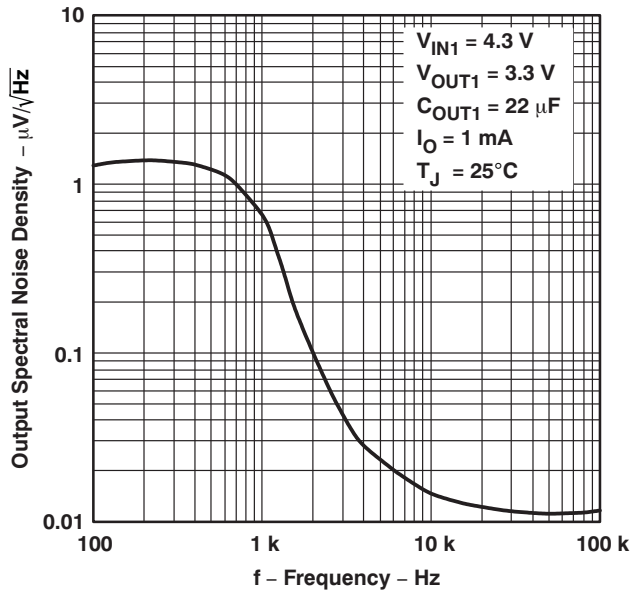

Figure 12.

OUTPUT SPECTRAL NOISE DENSITY  
 vs  
 FREQUENCY

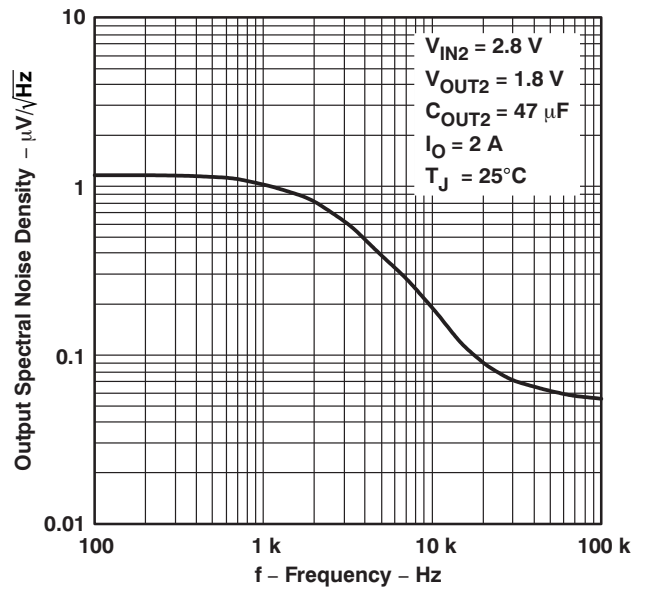

Figure 13.



TYPICAL CHARACTERISTICS (continued)

OUTPUT IMPEDANCE  
vs  
FREQUENCY

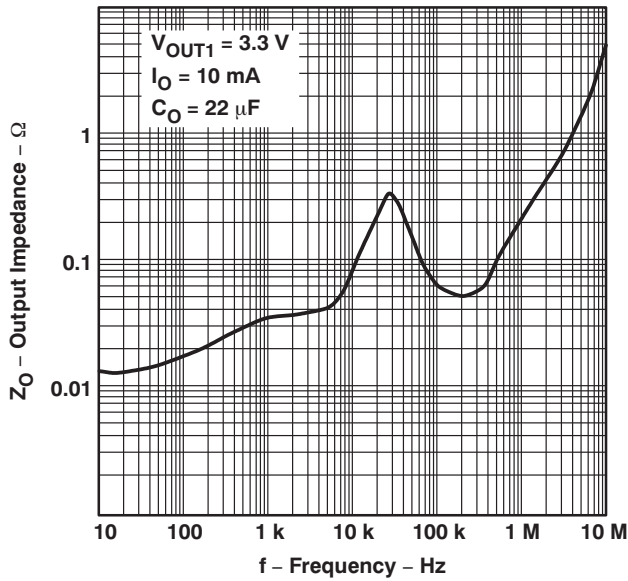

Figure 14.

OUTPUT IMPEDANCE  
vs  
FREQUENCY

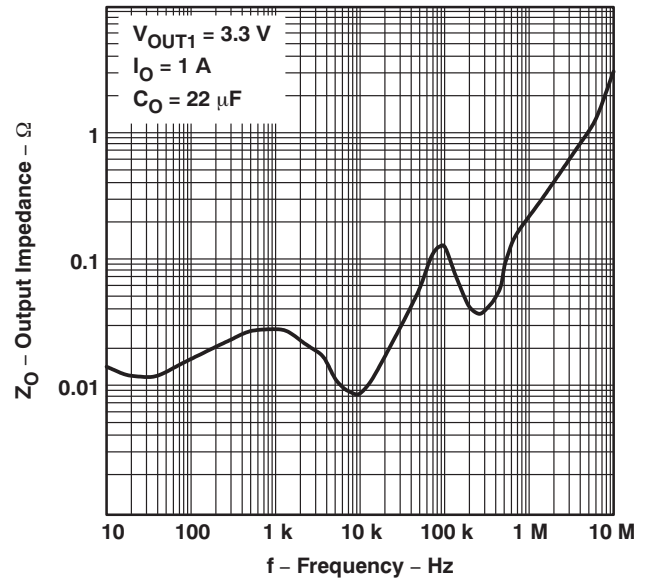

Figure 15.

OUTPUT IMPEDANCE  
vs  
FREQUENCY

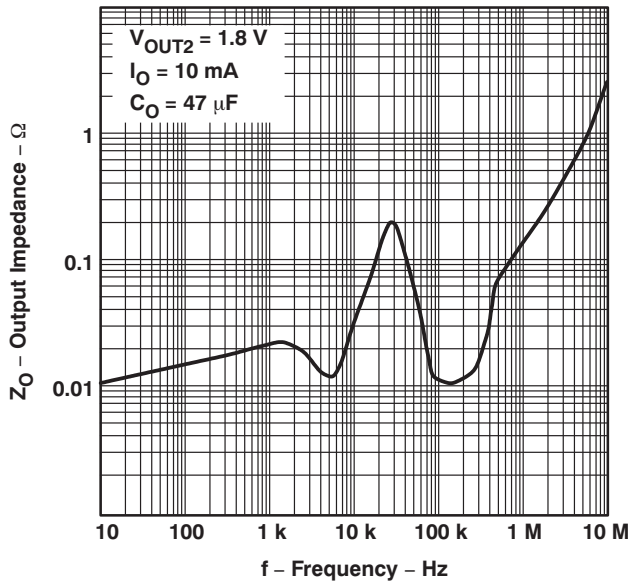

Figure 16.

OUTPUT IMPEDANCE  
vs  
FREQUENCY

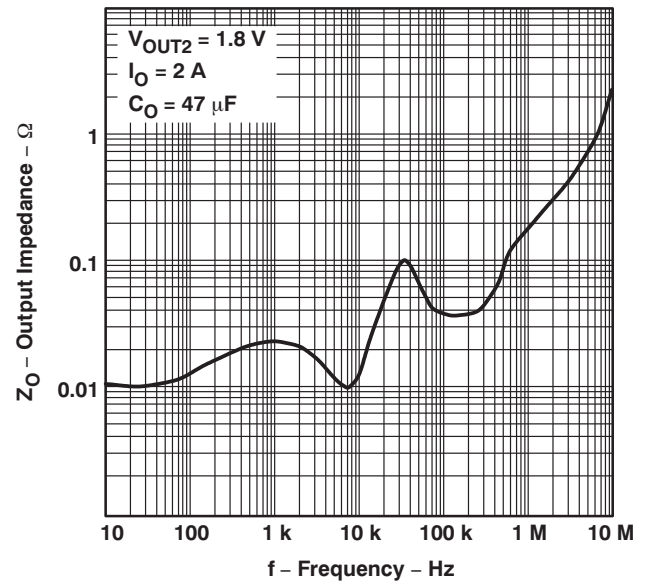
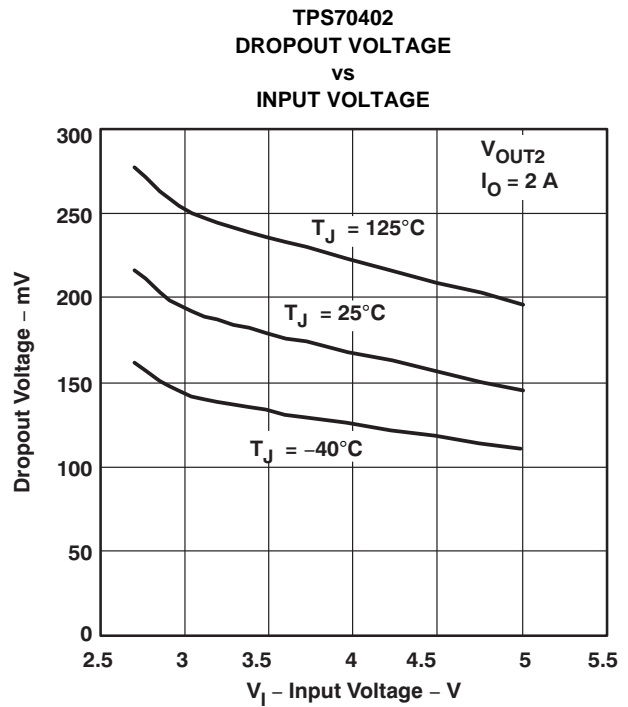
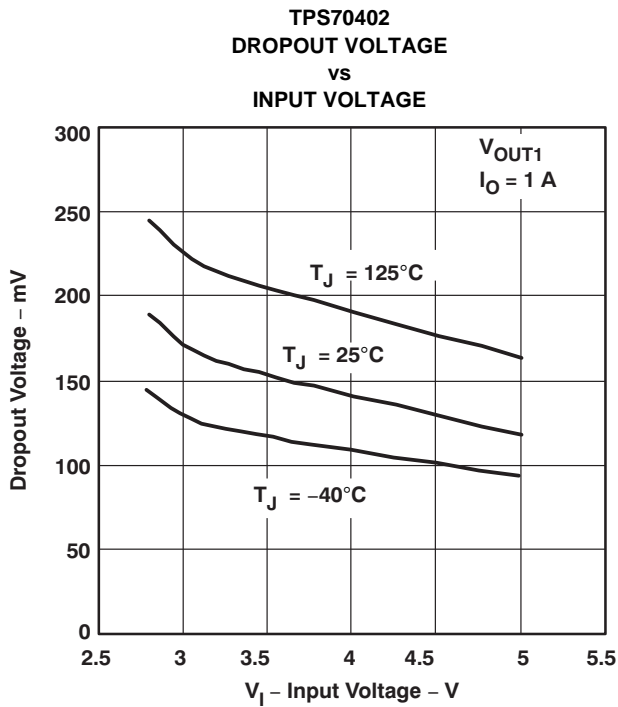
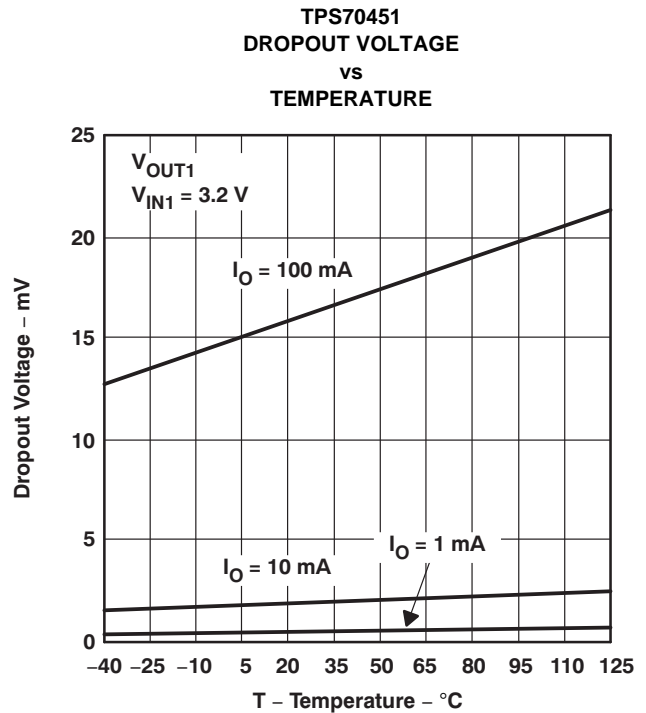
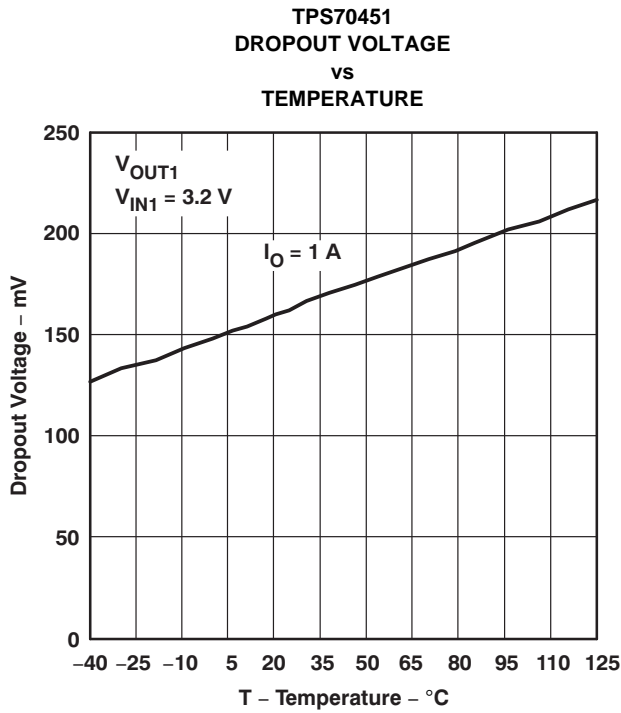

Figure 17.

TYPICAL CHARACTERISTICS (continued)



TYPICAL CHARACTERISTICS (continued)

LOAD TRANSIENT RESPONSE

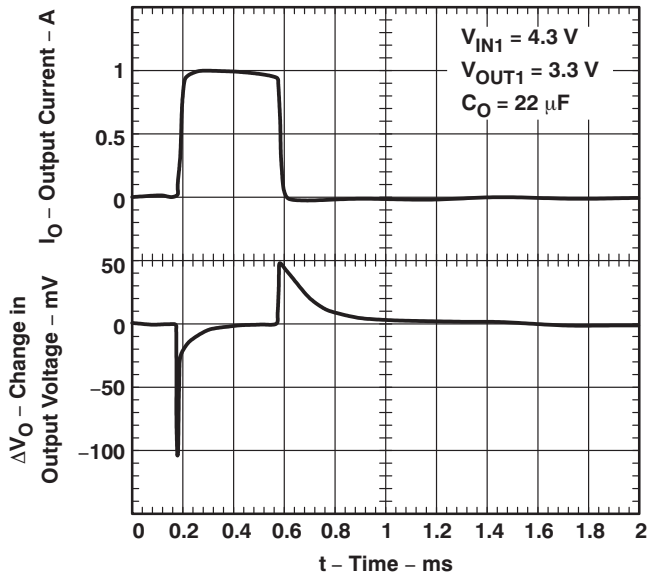

Figure 22.

LOAD TRANSIENT RESPONSE

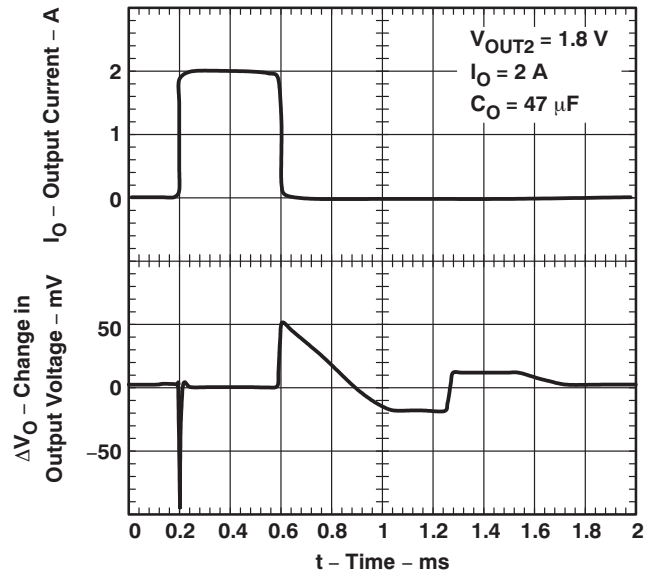

Figure 23.

LINE TRANSIENT RESPONSE

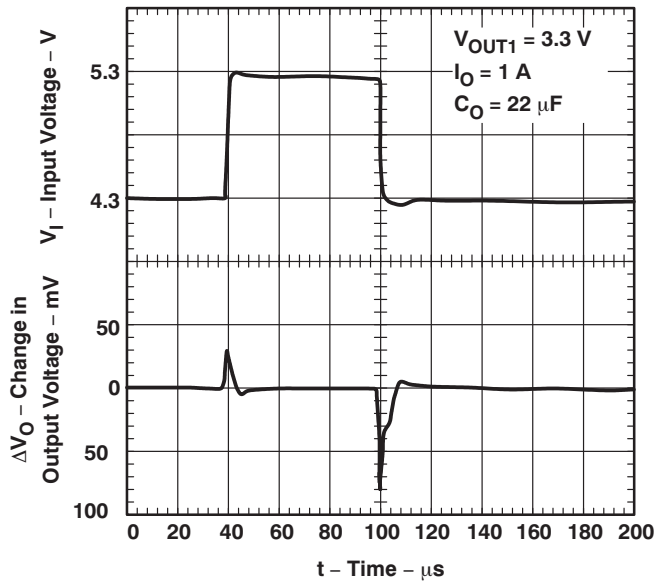

Figure 24.

LINE TRANSIENT RESPONSE

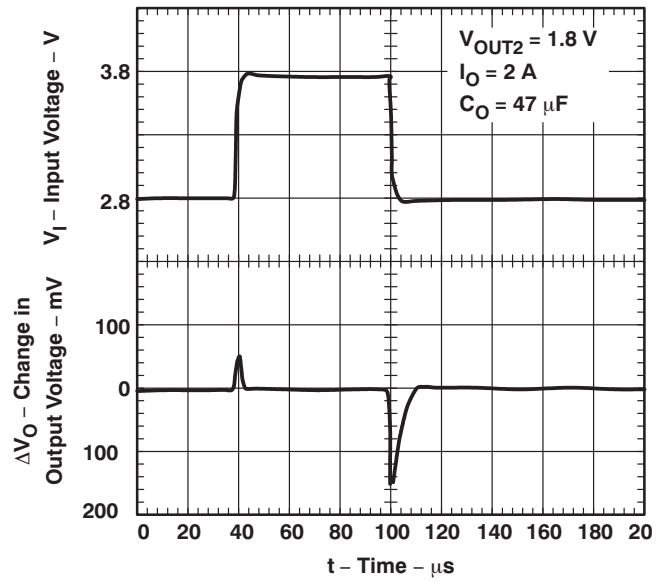

Figure 25.

TYPICAL CHARACTERISTICS (continued)

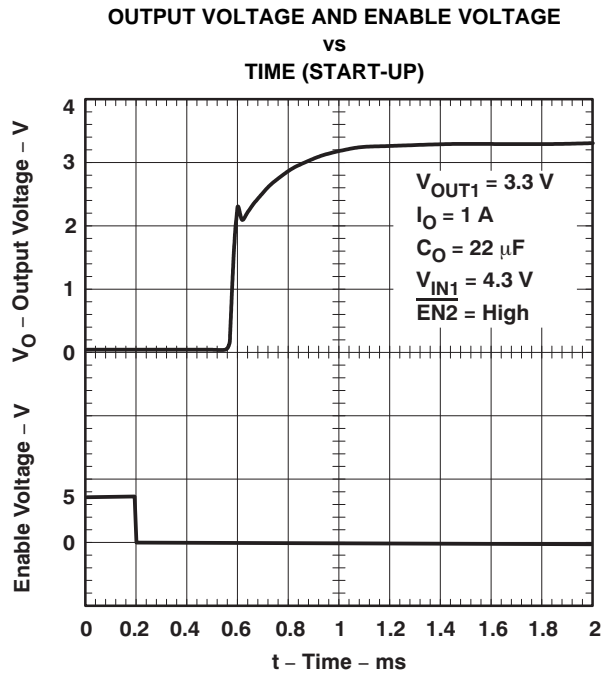

Figure 26.

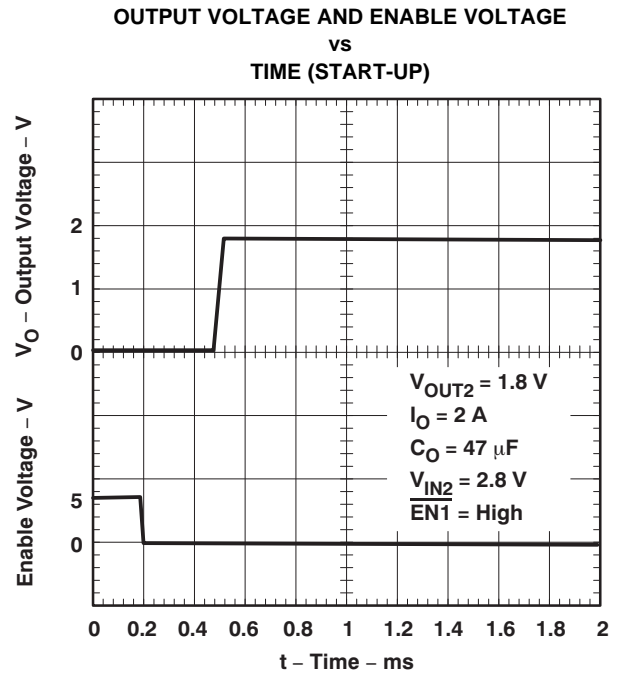

Figure 27.

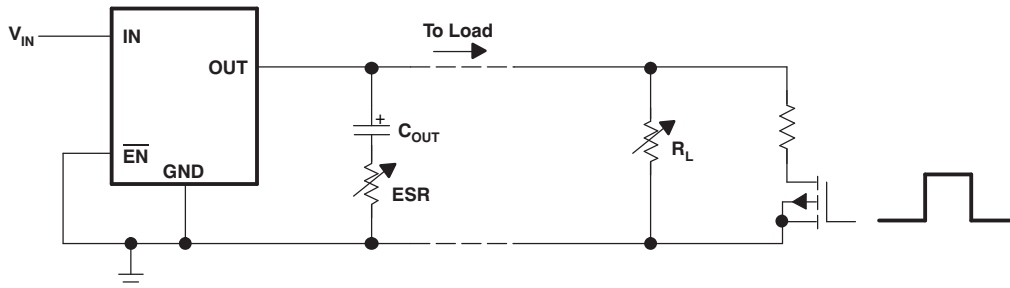

Figure 28. Test Circuit for Typical Regions of Stability

TYPICAL CHARACTERISTICS (continued)

TYPICAL REGION OF STABILITY  
EQUIVALENT SERIES RESISTANCE<sup>(1)</sup>

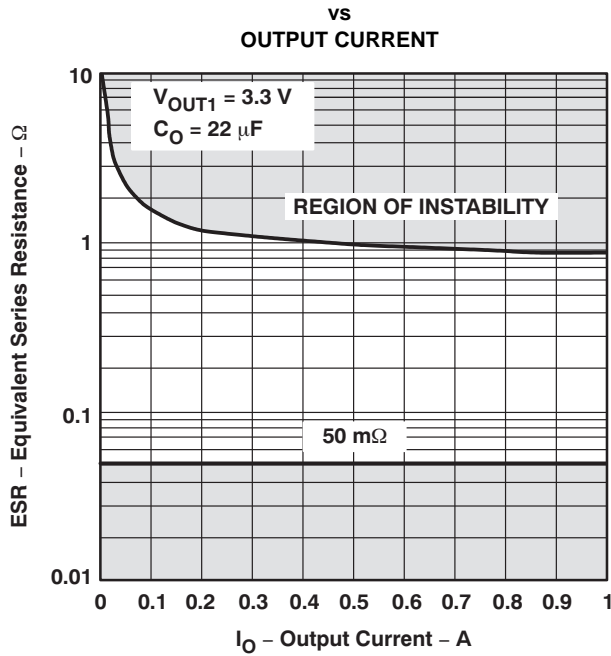

Figure 29.

TYPICAL REGION OF STABILITY  
EQUIVALENT SERIES RESISTANCE<sup>(1)</sup>

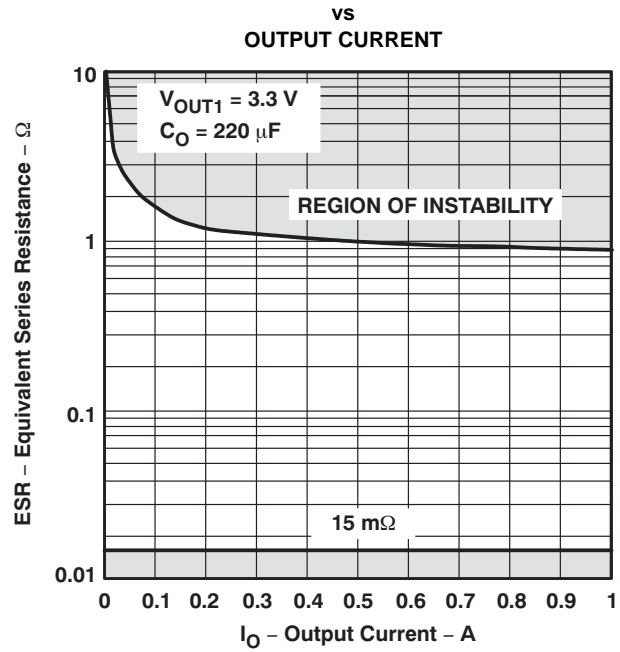

Figure 30.

TYPICAL REGION OF STABILITY  
EQUIVALENT SERIES RESISTANCE<sup>(1)</sup>

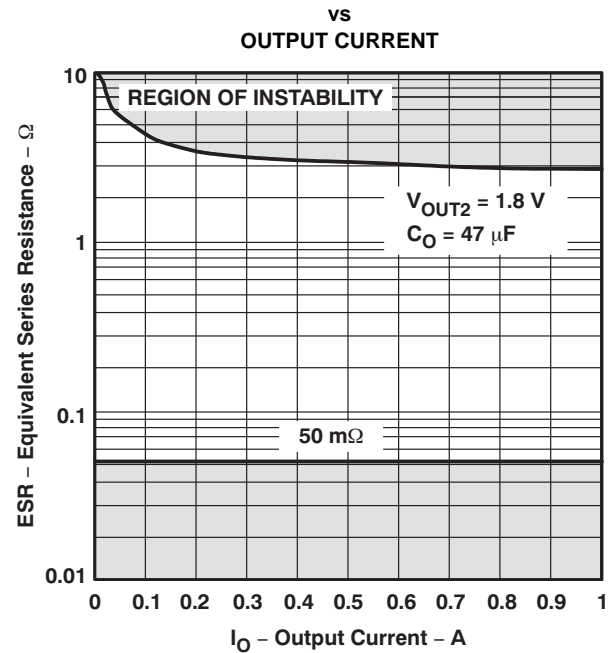

Figure 31.

TYPICAL REGION OF STABILITY  
EQUIVALENT SERIES RESISTANCE<sup>(1)</sup>

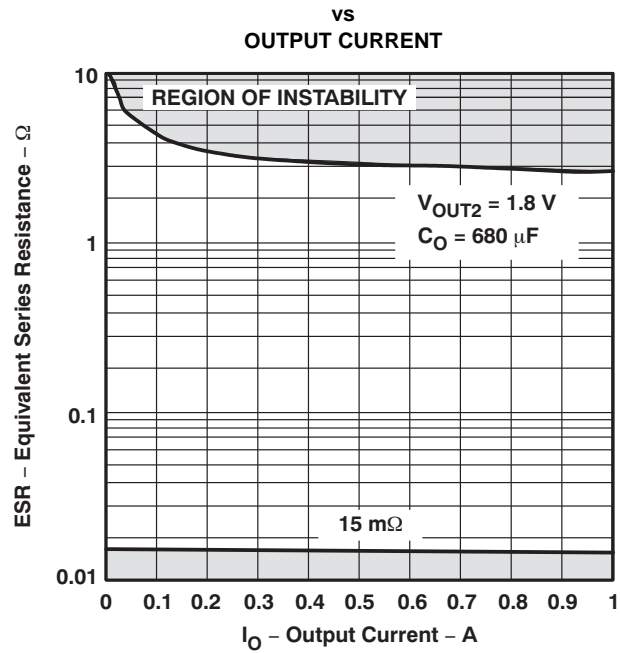

Figure 32.

<sup>(1)</sup> Equivalent series resistance (ESR) refers to the total series resistance, including the ESR of the capacitor, any series resistance added externally, and PWB trace resistance to  $C_O$ .

## THERMAL INFORMATION

### Thermally-Enhanced TSSOP-24 (PWP— PowerPAD™)

The thermally-enhanced PWP package is based on the 24-pin TSSOP, but includes a thermal pad [see [Figure 33\(c\)](#)] to provide an effective thermal contact between the IC and the printed wiring board (PWB).

Traditionally, surface mount and power have been mutually exclusive terms. A variety of scaled-down TO220-type packages have leads formed as gull wings to make them applicable for surface-mount applications. These packages, however, suffer from several shortcomings: they do not address the very low profile requirements (<2 mm) of many of today's advanced systems, and they do not offer a pin-count high enough to accommodate increasing integration. On the other hand, traditional low-power surface-mount packages require power-dissipation derating that severely limits the usable range of many high-performance analog circuits.

The PWP package (thermally-enhanced TSSOP) combines fine-pitch surface-mount technology with thermal performance comparable to much larger power packages.

The PWP package is designed to optimize the heat transfer to the PWB. Because of the very small size and limited mass of a TSSOP package, thermal enhancement is achieved by improving the thermal conduction paths that remove heat from the component. The thermal pad is formed using a lead-frame design (patent pending) and manufacturing technique to provide the user with direct connection to the heat-generating IC. When this pad is soldered or otherwise coupled to an external heat dissipator, high power dissipation in the ultrathin, fine-pitch, surface-mount package can be reliably achieved.

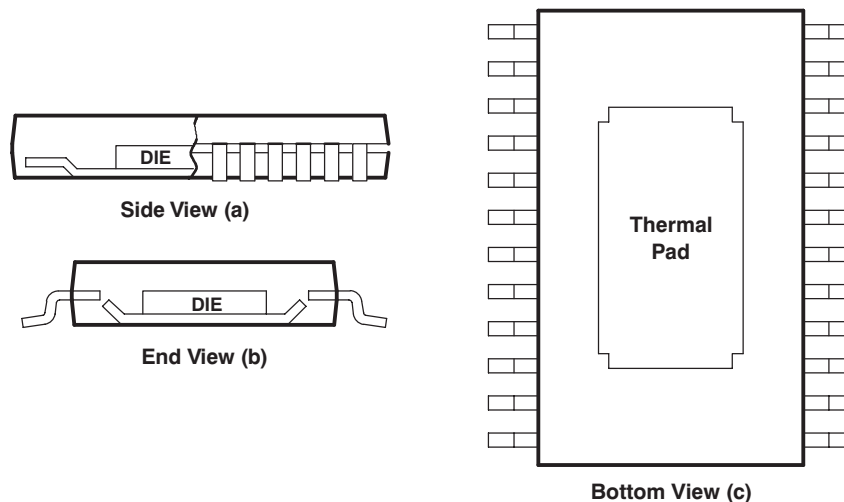

**Figure 33. Views of Thermally-Enhanced PWP Package**

Because the conduction path has been enhanced, power-dissipation capability is determined by the thermal considerations in the PWB design. For example, simply adding a localized copper plane (heat-sink surface), which is coupled to the thermal pad, enables the PWP package to dissipate 2.5 W in free air (reference [Figure 35\(a\)](#), 8 cm<sup>2</sup> of copper heat sink and natural convection). Increasing the heat-sink size increases the power dissipation range for the component. The power dissipation limit can be further improved by adding airflow to a PWB/IC assembly (see [Figure 34](#) and [Figure 35](#)). The line drawn at 0.3 cm<sup>2</sup> in [Figure 34](#) and [Figure 35](#) indicates performance at the minimum recommended heat-sink size, illustrated in [Figure 36](#).

The thermal pad is directly connected to the substrate of the IC, which for the TPS704xx series is a secondary electrical connection to device ground. The heat-sink surface that is added to the PWP can be a ground plane or left electrically isolated. In TO220-type surface-mount packages, the thermal connection is also the primary electrical connection for a given terminal which is not always ground. The PWP package provides up to 24 independent leads that can be used as inputs and outputs (**Note:** leads 1, 12, 13, and 24 are internally connected to the thermal pad and the IC substrate).

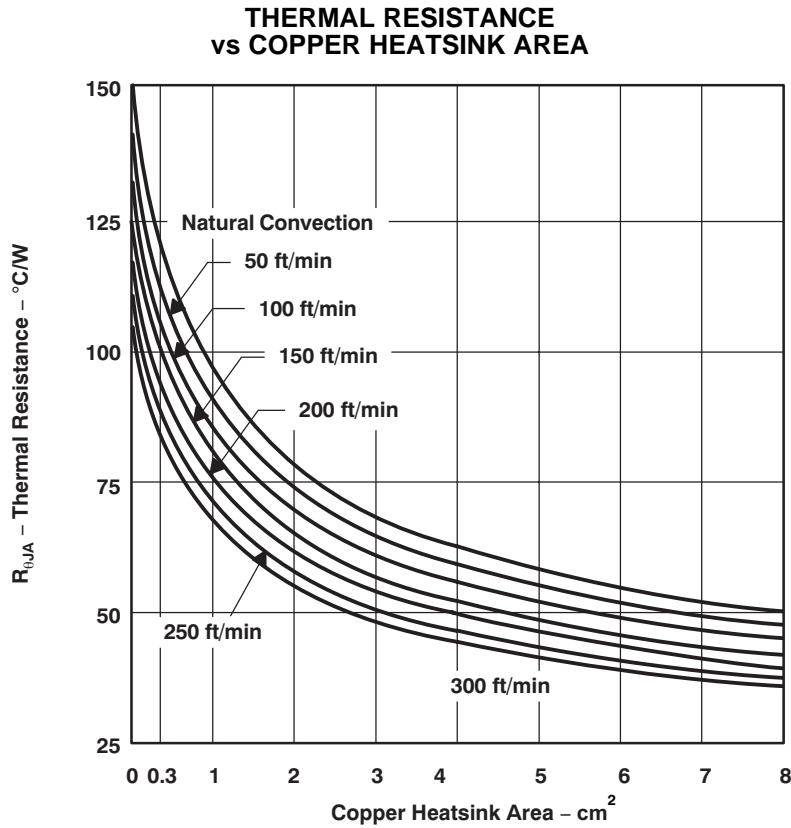
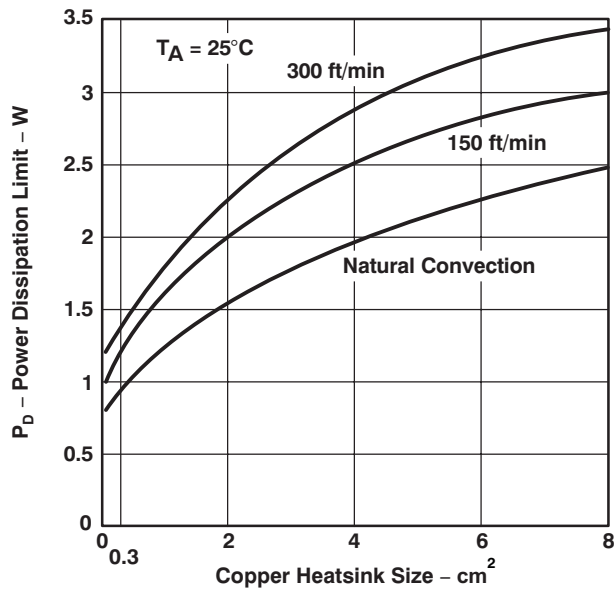
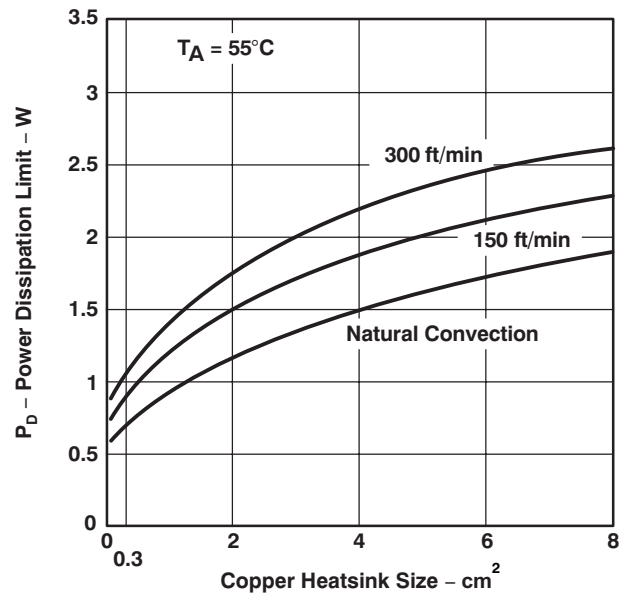

Figure 34.



(a)



(b)

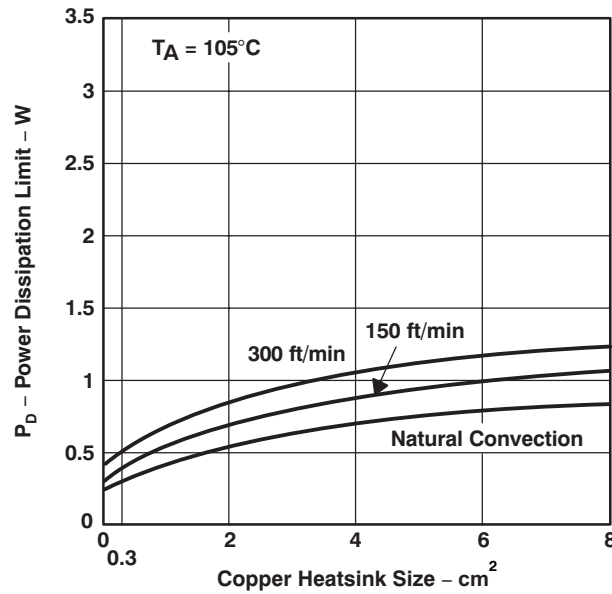

(c)

Figure 35. Power Ratings of the PWP Package at Ambient Temperatures of +25°C, +55°C, and +105°C



Figure 36 is an example of a thermally-enhanced PWB layout for use with the new PWP package. This board configuration was used in the thermal experiments that generated the power ratings shown in Figure 34 and Figure 35. As discussed earlier, copper has been added on the PWB to conduct heat away from the device.  $R_{\theta JA}$  for this assembly is illustrated in Figure 34 as a function of heat-sink area. A family of curves is included to illustrate the effect of airflow introduced into the system.

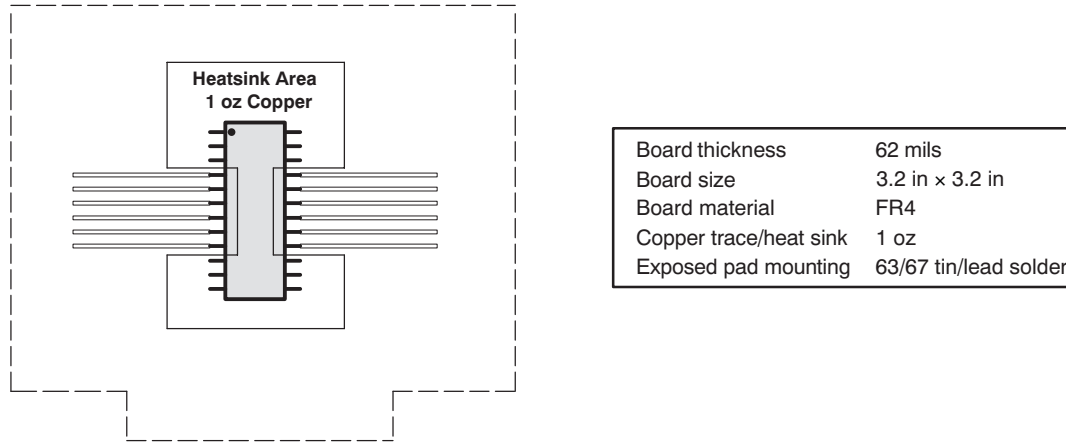

Figure 36. PWB Layout (Including Copper Heatsink Area) for Thermally-Enhanced PWP Package

From Figure 34,  $R_{\theta JA}$  for a PWB assembly can be determined and used to calculate the maximum power-dissipation limit for the component/PWB assembly, with the equation:

$$P_{D(max)} = \frac{T_{Jmax} - T_A}{R_{\theta JA(system)}}$$

where:

- $T_{Jmax}$  is the maximum specified junction temperature (+150°C absolute maximum limit, +125°C recommended operating limit) and  $T_A$  is the ambient temperature. (1)

$P_{D(max)}$  should then be applied to the internal power dissipated by the TPS704xx regulator. The equation for calculating total internal power dissipation of the TPS704xx is:

$$P_{D(total)} = (V_{IN1} - V_{OUT1}) \times I_{OUT1} + V_{IN1} \times \frac{I_Q}{2} + (V_{IN2} - V_{OUT2}) \times I_{OUT2} + V_{IN2} \times \frac{I_Q}{2} \quad (2)$$

Since the quiescent current of the TPS704xx is very low, the second term is negligible, further simplifying the equation to:

$$P_{D(total)} = (V_{IN1} - V_{OUT1}) \times I_{OUT1} + (V_{IN2} - V_{OUT2}) \times I_{OUT2} \quad (3)$$

For the case where  $T_A = +55^\circ\text{C}$ , airflow = 200 ft/min, copper heat-sink area = 4 cm<sup>2</sup>, the maximum power-dissipation limit can be calculated. First, from Figure 34, we find the system  $R_{\theta JA}$  is +50°C/W; therefore, the maximum power-dissipation limit is:

$$P_{D(max)} = \frac{T_{Jmax} - T_A}{R_{\theta JA(system)}} = \frac{+125^\circ\text{C} - 55^\circ\text{C}}{+50^\circ\text{C/W}} = 1.4 \text{ W} \quad (4)$$

If the system implements a TPS704xx regulator, where  $V_{IN1} = 5.0\text{V}$ ,  $V_{IN2} = 2.8 \text{ V}$ ,  $I_{OUT1} = 500 \text{ mA}$ , and  $I_{OUT2} = 800 \text{ mA}$ , the internal power dissipation is:

$$\begin{aligned} P_{D(total)} &= (V_{IN1} - V_{OUT1}) \times I_{OUT1} + (V_{IN2} - V_{OUT2}) \times I_{OUT2} \\ &= (5.0 - 3.3) \times 0.5 + (2.8 - 1.8) \times 0.8 = 1.25 \text{ W} \end{aligned} \quad (5)$$

Comparing  $P_{D(\text{total})}$  with  $P_{D(\text{max})}$  reveals that the power dissipation in this example does not exceed the calculated limit. When it does, one of two corrective actions should be made: raising the power-dissipation limit by increasing the airflow or the heat-sink area, or lowering the internal power dissipation of the regulator by reducing the input voltage or the load current. In either case, the above calculations should be repeated with the new system parameters. This parameter is measured with the recommended copper heat sink pattern on a 4-layer PWB, 2 oz. copper traces on 4-in x 4-in ground layer. Simultaneous and continuous operation of both regulator outputs at full load may exceed the power dissipation rating of the PWP package.

## Mounting Information

The primary requirement is to complete the thermal contact between the thermal pad and the PWB metal. The thermal pad is a solderable surface and is fully intended to be soldered at the time the component is mounted. Although voiding in the thermal-pad solder-connection is not desirable, up to 50% voiding is acceptable. The data included in [Figure 34](#) and [Figure 36](#) are for soldered connections with voiding between 20% and 50%. The thermal analysis shows no significant difference resulting from the variation in voiding percentage.

[Figure 37](#) shows the solder-mask land pattern for the PWP package. The minimum recommended heat-sink area is also illustrated. This is simply a copper plane under the body extent of the package, including metal routed under terminals 1, 12, 13, and 24.

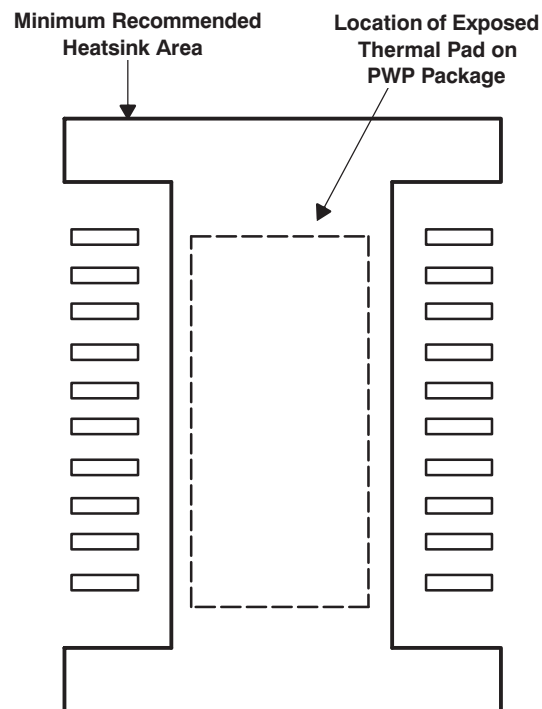

Figure 37. PWP Package Land Pattern

## APPLICATION INFORMATION

### Sequencing Timing Diagrams

This section provides a number of timing diagrams showing how this device functions in different configurations.

**Application condition:**  $V_{IN1}$  and  $V_{IN2}$  are tied to the same fixed input voltage greater than  $V_{UVLO}$ . PG2 is tied to  $\overline{MR}$ .

$\overline{EN1}$  and  $\overline{EN2}$  are initially high; therefore, both regulators are off, and PG1 and PG2 (tied to  $\overline{MR}$ ) are at logic low. Since  $\overline{MR}$  is at logic low,  $\overline{RESET}$  is also at logic low. When  $\overline{EN1}$  is taken to logic low,  $V_{OUT1}$  turns on. Later, when  $\overline{EN2}$  is taken to logic low,  $V_{OUT2}$  turns on. When  $V_{OUT1}$  reaches 95% of its regulated output voltage, PG1 goes to logic high. When  $V_{OUT2}$  reaches 95% of its regulated output voltage, PG2 (tied to  $\overline{MR}$ ) goes to logic high. When  $V_{IN1}$  is greater than  $V_{UVLO}$  and  $\overline{MR}$  (tied to PG2) is at logic high,  $\overline{RESET}$  is pulled to logic high after a 120-ms delay. When  $\overline{EN1}$  and  $\overline{EN2}$  are returned to logic high, both devices power down and both PG1, PG2 (tied to  $\overline{MR}$ ), and  $\overline{RESET}$  return to logic low.

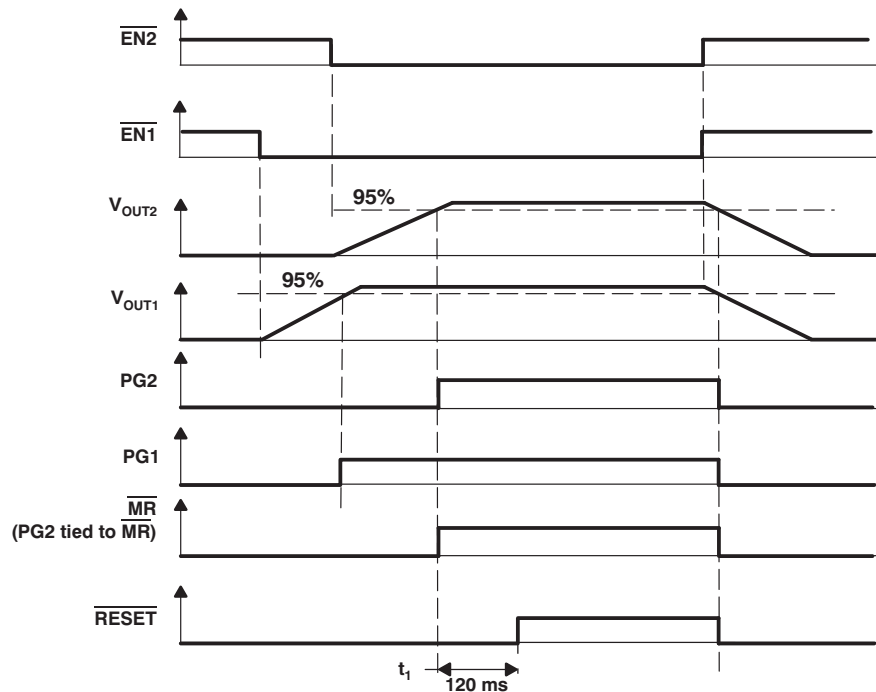
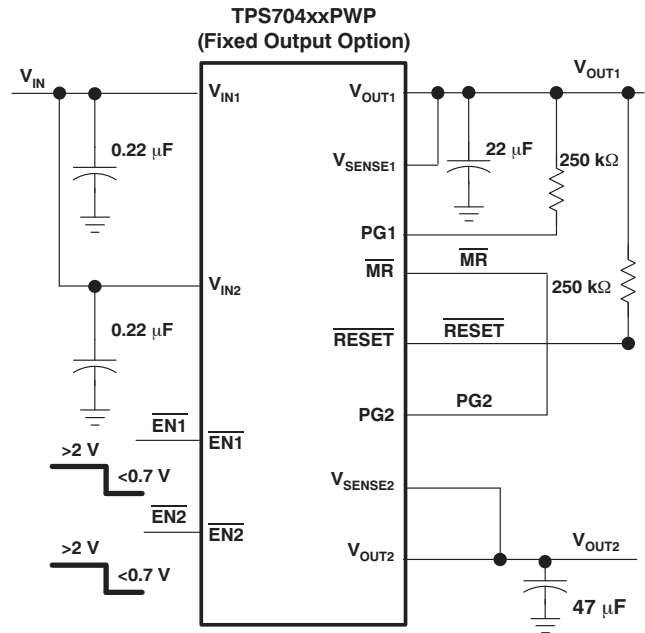

NOTES: A.  $t_1$ : Time at which  $V_{IN}$  is greater than  $V_{UVLO}$  and  $\overline{MR}$  is logic high.  
B. The timing diagram is not drawn to scale.

**Figure 38. Timing When  $V_{OUT1}$  Is Enabled Before  $V_{OUT2}$**

**Application condition:**  $V_{IN1}$  and  $V_{IN2}$  are tied to the same fixed input voltage greater than  $V_{UVLO}$ .  $\overline{MR}$  is initially logic high but is eventually toggled.

$\overline{EN1}$  and  $\overline{EN2}$  are initially high; therefore, both regulators are off, and PG1 and PG2 are at logic low. Since  $V_{IN1}$  is greater than  $V_{UVLO}$  and  $\overline{MR}$  is at logic high,  $\overline{RESET}$  is also at logic high. When  $\overline{EN2}$  is taken to logic low,  $V_{OUT2}$  turns on. Later, when  $\overline{EN1}$  is taken to logic low,  $V_{OUT1}$  turns on. When  $V_{OUT2}$  reaches 95% of its regulated output voltage, PG2 goes to logic high. When  $V_{OUT1}$  reaches 95% of its regulated output voltage, PG1 goes to logic high. When  $\overline{MR}$  is taken to logic low,  $\overline{RESET}$  is taken low. When  $\overline{MR}$  returns to logic high,  $\overline{RESET}$  returns to logic high after a 120-ms delay.

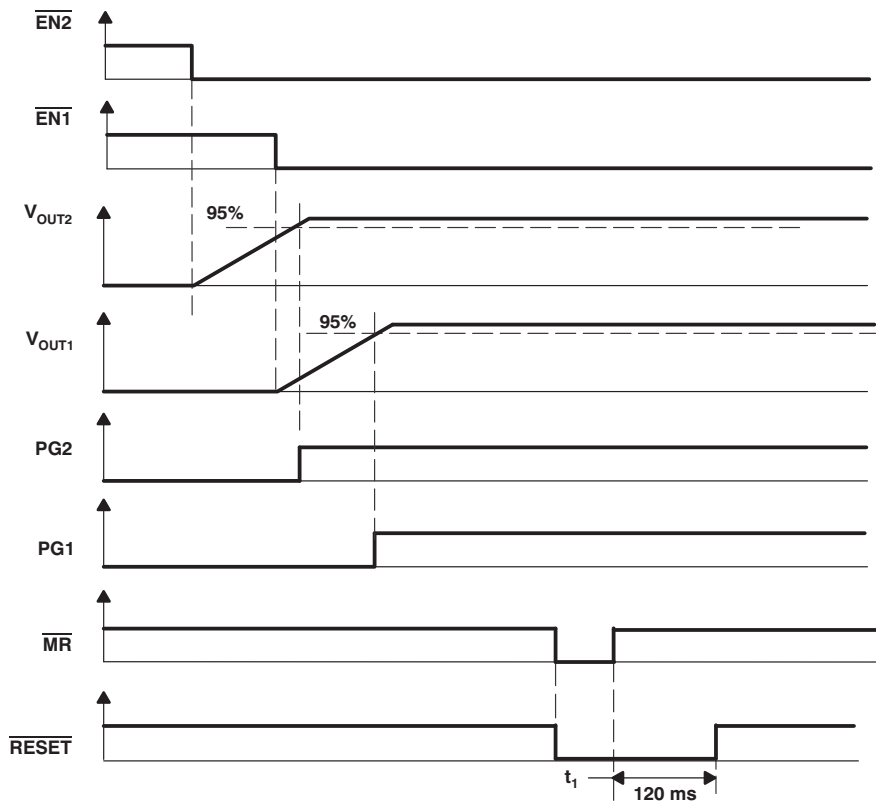
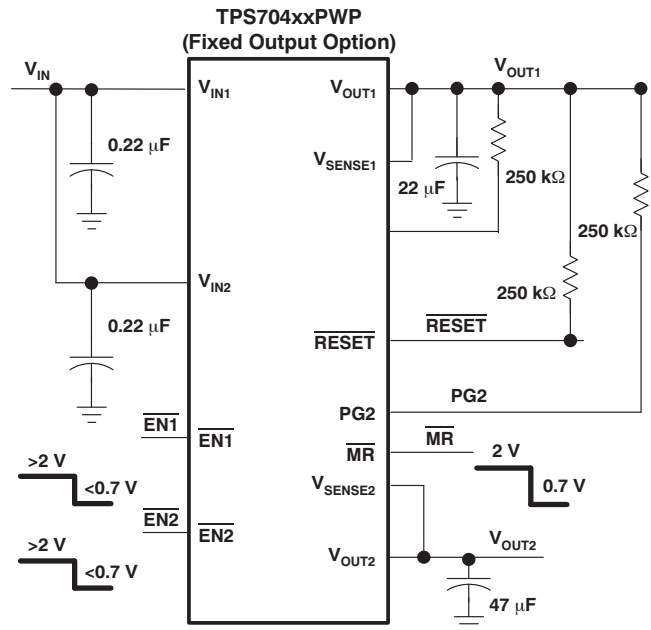

NOTES: A.  $t_1$ : Time at which  $V_{IN}$  is greater than  $V_{UVLO}$  and  $\overline{MR}$  is logic high.  
 B. The timing diagram is not drawn to scale.

**Figure 39. Timing When  $\overline{MR}$  is Toggled**

**Application condition:**  $V_{IN1}$  and  $V_{IN2}$  are tied to same fixed input voltage greater than  $V_{UVLO}$ .  $\overline{PG1}$  is tied to  $\overline{MR}$ .

$\overline{EN1}$  and  $\overline{EN2}$  are initially high; therefore, both regulators are off, and  $\overline{PG1}$  (tied to  $\overline{MR}$ ) and  $\overline{PG2}$  are at logic low. Since  $\overline{MR}$  is at logic low,  $\overline{RESET}$  is also at logic low. When  $\overline{EN2}$  is taken to logic low,  $V_{OUT2}$  turns on. Later, when  $\overline{EN1}$  is taken to logic low,  $V_{OUT1}$  turns on. When  $V_{OUT2}$  reaches 95% of its regulated output voltage,  $\overline{PG2}$  goes to logic high. When  $V_{OUT1}$  reaches 95% of its regulated output voltage,  $\overline{PG1}$  goes to logic high. When  $V_{IN1}$  is greater than  $V_{UVLO}$  and  $\overline{MR}$  (tied to  $\overline{PG2}$ ) is at logic high,  $\overline{RESET}$  is pulled to logic high after a 120-ms delay. When a fault on  $V_{OUT1}$  causes it to fall below 95% of its regulated output voltage,  $\overline{PG1}$  (tied to  $\overline{MR}$ ) goes to logic low. Since  $\overline{MR}$  is logic low,  $\overline{RESET}$  goes to logic low.  $V_{OUT2}$  is unaffected.

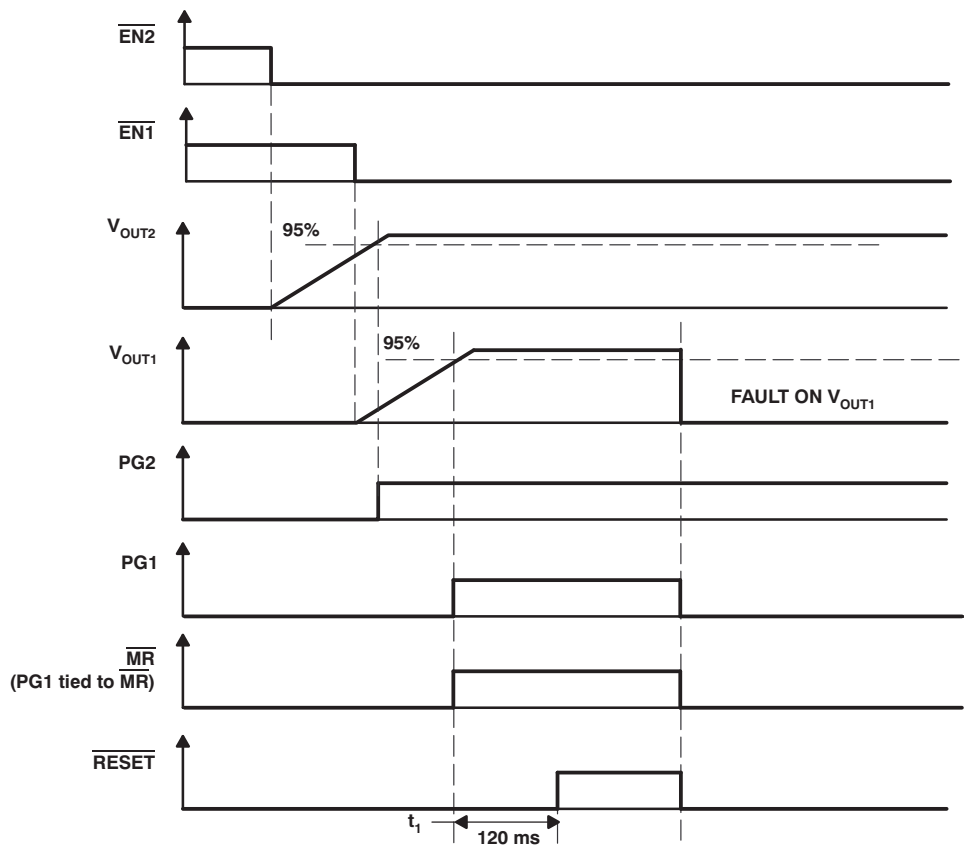
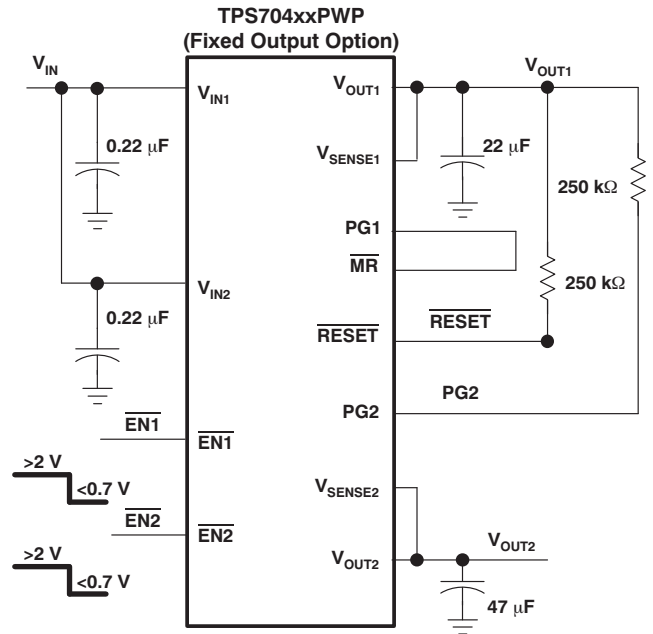

NOTES: A.  $t_1$ : Time at which  $V_{IN}$  is greater than  $V_{UVLO}$  and  $\overline{MR}$  is logic high.  
B. The timing diagram is not drawn to scale.

**Figure 40. Timing When There is a Fault on  $V_{OUT1}$**

## APPLICATION INFORMATION

### Input Capacitor

For a typical application, a ceramic input bypass capacitor (0.22  $\mu\text{F}$  to 1  $\mu\text{F}$ ) is recommended. This capacitor should be as close to the input pins as possible. Due to the impedance of the input supply, large transient currents cause the input voltage to droop. If this droop causes the input voltage to drop below the UVLO threshold, the device turns off. Therefore, it is recommended to place a larger capacitor in parallel with the ceramic bypass capacitor at the regulator input. The size of this capacitor depends on the output current, the response time of the main power supply, and the main power supply distance to the regulator. At a minimum, the capacitor should be sized to ensure that the input voltage does not drop below the minimum UVLO threshold voltage during normal operating conditions.

### Output Capacitor

As with most LDO regulators, the TPS704xx requires an output capacitor connected between OUT and GND to stabilize the internal control loop. The minimum recommended capacitance value for  $V_{\text{OUT}1}$  is 22  $\mu\text{F}$  and the ESR (equivalent series resistance) must be between 50 m $\Omega$  and 800 m $\Omega$ . The minimum recommended capacitance value for  $V_{\text{OUT}2}$  is 47  $\mu\text{F}$  and the ESR must be between 50 m $\Omega$  and 2  $\Omega$ . Solid tantalum electrolytic, aluminum electrolytic, and multilayer ceramic capacitors are all suitable, provided they meet the requirements described above. Larger capacitors provide a wider range of stability and better load transient response. [Table 1](#) gives a partial listing of surface-mount capacitors suitable for use with the TPS704xx for fast transient response applications.

This information, along with the ESR graphs, is included to assist in selection of suitable capacitance for user applications. When necessary to achieve low height requirements along with high output current and/or high load capacitance, several higher ESR capacitors can be used in parallel to meet the guidelines above.

**Table 1. Partial Listing of TPS704xx-Compatible Surface-Mount Capacitors**

VALUE	MANUFACTURER	MFR PART NO.
680 $\mu\text{F}$	Kemet	T510X6871004AS
470 $\mu\text{F}$	Sanyo	4TPB470M
150 $\mu\text{F}$	Sanyo	4TPC150M
220 $\mu\text{F}$	Sanyo	2R5TPC220M
100 $\mu\text{F}$	Sanyo	2R5TPC220M
68 $\mu\text{F}$	Sanyo	10TPC68M
68 $\mu\text{F}$	Kemet	T495D6861006AS
47 $\mu\text{F}$	Kemet	T495D4761010AS
33 $\mu\text{F}$	Kemet	T495C3361016AS
22 $\mu\text{F}$	Kemet	T495C2261010AS

## Programming the TPS70402 Adjustable LDO Regulator

The output voltage of the TPS70402 adjustable regulators is programmed using external resistor dividers as shown in Figure 41.

Resistors R1 and R2 should be chosen for approximately a 50- $\mu$ A divider current. Lower value resistors can be used, but offer no inherent advantage and waste more power. Higher values should be avoided as leakage currents at the sense terminal increase the output voltage error. The recommended design procedure is to choose R2 = 30.1 k $\Omega$  to set the divider current at approximately 50  $\mu$ A, and then calculate R1 using Equation 6:

$$R1 = \left( \frac{V_{OUT}}{V_{REF}} - 1 \right) \times R2 \quad (6)$$

where:

- $V_{REF}$  = 1.224 V typ (the internal reference voltage)

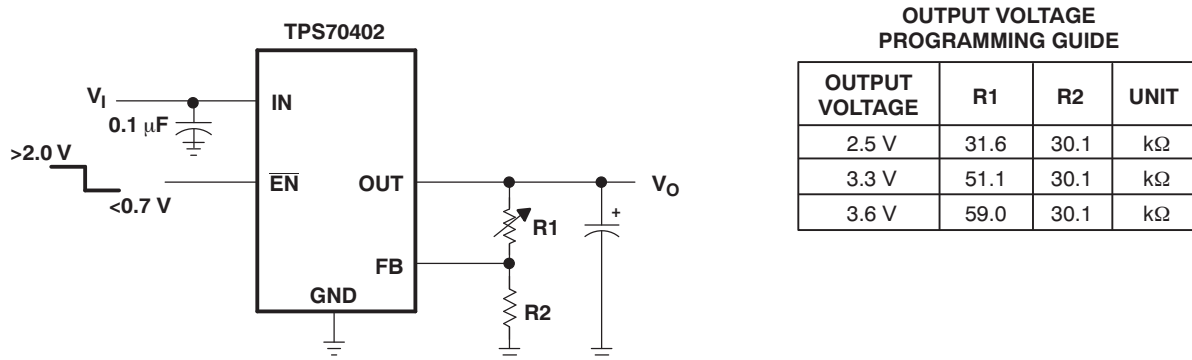

Figure 41. TPS70402 Adjustable LDO Regulator Programming

## Regulator Protection

Both TPS704xx PMOS-pass transistors have built-in back diodes that conduct reverse currents when the input voltage drops below the output voltage (for example, during power-down). Current is conducted from the output to the input and is not internally limited. When extended reverse voltage is anticipated, external limiting may be appropriate.

The TPS704xx also features internal current limiting and thermal protection. During normal operation, the TPS704xx regulator 1 limits output current to approximately 1.75 A (typ) and regulator 2 limits output current to approximately 3.8 A (typ). When current limiting engages, the output voltage scales back linearly until the overcurrent condition ends. While current limiting is designed to prevent gross device failure, care should be taken not to exceed the power dissipation ratings of the package. If the temperature of the device exceeds +150°C (typ), thermal-protection circuitry shuts it down. Once the device has cooled below +130°C (typ), regulator operation resumes.

## REVISION HISTORY

NOTE: Page numbers for previous revisions may differ from page numbers in the current version.

---

### Changes from Revision E (February 2010) to Revision F Page

- Changed *Tube* transport media, quantity values from 70 to 60 in Ordering Information table ..... 3
- 

---

### Changes from Revision D (December, 2007) to Revision E Page

- Corrected pin description for pin 21 in pinout drawing ..... 1
  - Updated *Dissipation Ratings* table values ..... 4
  - Deleted *falling edge delay* specification ..... 6
  - Updated *Fixed Voltage Version* block diagram ..... 7
  - Updated *Adjustable Voltage Version* block diagram ..... 8
-



**PACKAGING INFORMATION**

Orderable part number	Status (1)	Material type (2)	Package   Pins	Package qty   Carrier	RoHS (3)	Lead finish/ Ball material (4)	MSL rating/ Peak reflow (5)	Op temp (°C)	Part marking (6)
<a href="#">TPS70402PWP</a>	Active	Production	HTSSOP (PWP)   24	60   TUBE	Yes	NIPDAU	Level-2-260C-1 YEAR	-40 to 125	PT70402
TPS70402PWP.A	Active	Production	HTSSOP (PWP)   24	60   TUBE	Yes	NIPDAU	Level-2-260C-1 YEAR	-40 to 125	PT70402
TPS70402PWPG4	Active	Production	HTSSOP (PWP)   24	60   TUBE	Yes	NIPDAU	Level-2-260C-1 YEAR	-40 to 125	PT70402
<a href="#">TPS70402PWPR</a>	Active	Production	HTSSOP (PWP)   24	2000   LARGE T&R	Yes	NIPDAU	Level-2-260C-1 YEAR	-40 to 125	PT70402
TPS70402PWPR.A	Active	Production	HTSSOP (PWP)   24	2000   LARGE T&R	Yes	NIPDAU	Level-2-260C-1 YEAR	-40 to 125	PT70402
<a href="#">TPS70445PWP</a>	Active	Production	HTSSOP (PWP)   24	60   TUBE	Yes	NIPDAU	Level-2-260C-1 YEAR	-40 to 125	PT70445
TPS70445PWP.A	Active	Production	HTSSOP (PWP)   24	60   TUBE	Yes	NIPDAU	Level-2-260C-1 YEAR	-40 to 125	PT70445
<a href="#">TPS70445PWPR</a>	Active	Production	HTSSOP (PWP)   24	2000   LARGE T&R	Yes	NIPDAU	Level-2-260C-1 YEAR	-40 to 125	PT70445
TPS70445PWPR.A	Active	Production	HTSSOP (PWP)   24	2000   LARGE T&R	Yes	NIPDAU	Level-2-260C-1 YEAR	-40 to 125	PT70445
<a href="#">TPS70448PWP</a>	Active	Production	HTSSOP (PWP)   24	60   TUBE	Yes	NIPDAU	Level-2-260C-1 YEAR	-40 to 125	PT70448
TPS70448PWP.A	Active	Production	HTSSOP (PWP)   24	60   TUBE	Yes	NIPDAU	Level-2-260C-1 YEAR	-40 to 125	PT70448
<a href="#">TPS70448PWPR</a>	Active	Production	HTSSOP (PWP)   24	2000   LARGE T&R	Yes	NIPDAU	Level-2-260C-1 YEAR	-40 to 125	PT70448
TPS70448PWPR.A	Active	Production	HTSSOP (PWP)   24	2000   LARGE T&R	Yes	NIPDAU	Level-2-260C-1 YEAR	-40 to 125	PT70448
<a href="#">TPS70451PWP</a>	Active	Production	HTSSOP (PWP)   24	60   TUBE	Yes	NIPDAU	Level-2-260C-1 YEAR	-40 to 125	PT70451
TPS70451PWP.A	Active	Production	HTSSOP (PWP)   24	60   TUBE	Yes	NIPDAU	Level-2-260C-1 YEAR	-40 to 125	PT70451
<a href="#">TPS70451PWPR</a>	Active	Production	HTSSOP (PWP)   24	2000   LARGE T&R	Yes	NIPDAU	Level-2-260C-1 YEAR	-40 to 125	PT70451
TPS70451PWPR.A	Active	Production	HTSSOP (PWP)   24	2000   LARGE T&R	Yes	NIPDAU	Level-2-260C-1 YEAR	-40 to 125	PT70451
<a href="#">TPS70458PWP</a>	Active	Production	HTSSOP (PWP)   24	60   TUBE	Yes	NIPDAU	Level-2-260C-1 YEAR	-40 to 125	PT70458
TPS70458PWP.A	Active	Production	HTSSOP (PWP)   24	60   TUBE	Yes	NIPDAU	Level-2-260C-1 YEAR	-40 to 125	PT70458
<a href="#">TPS70458PWPR</a>	Active	Production	HTSSOP (PWP)   24	2000   LARGE T&R	Yes	NIPDAU	Level-2-260C-1 YEAR	-40 to 125	PT70458
TPS70458PWPR.A	Active	Production	HTSSOP (PWP)   24	2000   LARGE T&R	Yes	NIPDAU	Level-2-260C-1 YEAR	-40 to 125	PT70458

(1) **Status:** For more details on status, see our [product life cycle](#).

(2) **Material type:** When designated, preproduction parts are prototypes/experimental devices, and are not yet approved or released for full production. Testing and final process, including without limitation quality assurance, reliability performance testing, and/or process qualification, may not yet be complete, and this item is subject to further changes or possible discontinuation. If available for ordering, purchases will be subject to an additional waiver at checkout, and are intended for early internal evaluation purposes only. These items are sold without warranties of any kind.

(3) **RoHS values:** Yes, No, RoHS Exempt. See the [TI RoHS Statement](#) for additional information and value definition.

- (4) **Lead finish/Ball material:** Parts may have multiple material finish options. Finish options are separated by a vertical ruled line. Lead finish/Ball material values may wrap to two lines if the finish value exceeds the maximum column width.
- (5) **MSL rating/Peak reflow:** The moisture sensitivity level ratings and peak solder (reflow) temperatures. In the event that a part has multiple moisture sensitivity ratings, only the lowest level per JEDEC standards is shown. Refer to the shipping label for the actual reflow temperature that will be used to mount the part to the printed circuit board.
- (6) **Part marking:** There may be an additional marking, which relates to the logo, the lot trace code information, or the environmental category of the part.

Multiple part markings will be inside parentheses. Only one part marking contained in parentheses and separated by a "~" will appear on a part. If a line is indented then it is a continuation of the previous line and the two combined represent the entire part marking for that device.

**Important Information and Disclaimer:** The information provided on this page represents TI's knowledge and belief as of the date that it is provided. TI bases its knowledge and belief on information provided by third parties, and makes no representation or warranty as to the accuracy of such information. Efforts are underway to better integrate information from third parties. TI has taken and continues to take reasonable steps to provide representative and accurate information but may not have conducted destructive testing or chemical analysis on incoming materials and chemicals. TI and TI suppliers consider certain information to be proprietary, and thus CAS numbers and other limited information may not be available for release.

In no event shall TI's liability arising out of such information exceed the total purchase price of the TI part(s) at issue in this document sold by TI to Customer on an annual basis.

**TAPE AND REEL INFORMATION**

**QUADRANT ASSIGNMENTS FOR PIN 1 ORIENTATION IN TAPE**

\*All dimensions are nominal

Device	Package Type	Package Drawing	Pins	SPQ	Reel Diameter (mm)	Reel Width W1 (mm)	A0 (mm)	B0 (mm)	K0 (mm)	P1 (mm)	W (mm)	Pin1 Quadrant
TPS70402PWPR	HTSSOP	PWP	24	2000	330.0	16.4	6.95	8.3	1.6	8.0	16.0	Q1
TPS70445PWPR	HTSSOP	PWP	24	2000	330.0	16.4	6.95	8.3	1.6	8.0	16.0	Q1
TPS70448PWPR	HTSSOP	PWP	24	2000	330.0	16.4	6.95	8.3	1.6	8.0	16.0	Q1
TPS70451PWPR	HTSSOP	PWP	24	2000	330.0	16.4	6.95	8.3	1.6	8.0	16.0	Q1
TPS70458PWPR	HTSSOP	PWP	24	2000	330.0	16.4	6.95	8.3	1.6	8.0	16.0	Q1

**TAPE AND REEL BOX DIMENSIONS**

\*All dimensions are nominal

Device	Package Type	Package Drawing	Pins	SPQ	Length (mm)	Width (mm)	Height (mm)
TPS70402PWPR	HTSSOP	PWP	24	2000	350.0	350.0	43.0
TPS70445PWPR	HTSSOP	PWP	24	2000	350.0	350.0	43.0
TPS70448PWPR	HTSSOP	PWP	24	2000	350.0	350.0	43.0
TPS70451PWPR	HTSSOP	PWP	24	2000	350.0	350.0	43.0
TPS70458PWPR	HTSSOP	PWP	24	2000	350.0	350.0	43.0

**TUBE**

\*All dimensions are nominal

Device	Package Name	Package Type	Pins	SPQ	L (mm)	W (mm)	T (μm)	B (mm)
TPS70402PWP	PWP	HTSSOP	24	60	530	10.2	3600	3.5
TPS70402PWP.A	PWP	HTSSOP	24	60	530	10.2	3600	3.5
TPS70402PWPG4	PWP	HTSSOP	24	60	530	10.2	3600	3.5
TPS70445PWP	PWP	HTSSOP	24	60	530	10.2	3600	3.5
TPS70445PWP.A	PWP	HTSSOP	24	60	530	10.2	3600	3.5
TPS70448PWP	PWP	HTSSOP	24	60	530	10.2	3600	3.5
TPS70448PWP.A	PWP	HTSSOP	24	60	530	10.2	3600	3.5
TPS70451PWP	PWP	HTSSOP	24	60	530	10.2	3600	3.5
TPS70451PWP.A	PWP	HTSSOP	24	60	530	10.2	3600	3.5
TPS70458PWP	PWP	HTSSOP	24	60	530	10.2	3600	3.5
TPS70458PWP.A	PWP	HTSSOP	24	60	530	10.2	3600	3.5

## GENERIC PACKAGE VIEW

**PWP 24**

**PowerPAD™ TSSOP - 1.2 mm max height**

4.4 x 7.6, 0.65 mm pitch

PLASTIC SMALL OUTLINE

This image is a representation of the package family, actual package may vary.  
Refer to the product data sheet for package details.



4224742/B

# MECHANICAL DATA

PWP (R-PDSO-G24)

PowerPAD™ PLASTIC SMALL OUTLINE



- NOTES:
- All linear dimensions are in millimeters.
  - This drawing is subject to change without notice.
  - Body dimensions do not include mold flash or protrusions. Mold flash and protrusion shall not exceed 0.15 per side.
  - This package is designed to be soldered to a thermal pad on the board. Refer to Technical Brief, PowerPad Thermally Enhanced Package, Texas Instruments Literature No. SLMA002 for information regarding recommended board layout. This document is available at [www.ti.com](http://www.ti.com) <<http://www.ti.com>>.
  - See the additional figure in the Product Data Sheet for details regarding the exposed thermal pad features and dimensions.
  - Falls within JEDEC MO-153

PowerPAD is a trademark of Texas Instruments.

# THERMAL PAD MECHANICAL DATA

## PWP (R-PDSO-G24) PowerPAD™ SMALL PLASTIC OUTLINE

### THERMAL INFORMATION

This PowerPAD™ package incorporates an exposed thermal pad that is designed to be attached to a printed circuit board (PCB). The thermal pad must be soldered directly to the PCB. After soldering, the PCB can be used as a heatsink. In addition, through the use of thermal vias, the thermal pad can be attached directly to the appropriate copper plane shown in the electrical schematic for the device, or alternatively, can be attached to a special heatsink structure designed into the PCB. This design optimizes the heat transfer from the integrated circuit (IC).

For additional information on the PowerPAD package and how to take advantage of its heat dissipating abilities, refer to Technical Brief, PowerPAD Thermally Enhanced Package, Texas Instruments Literature No. SLMA002 and Application Brief, PowerPAD Made Easy, Texas Instruments Literature No. SLMA004. Both documents are available at [www.ti.com](http://www.ti.com).

The exposed thermal pad dimensions for this package are shown in the following illustration.

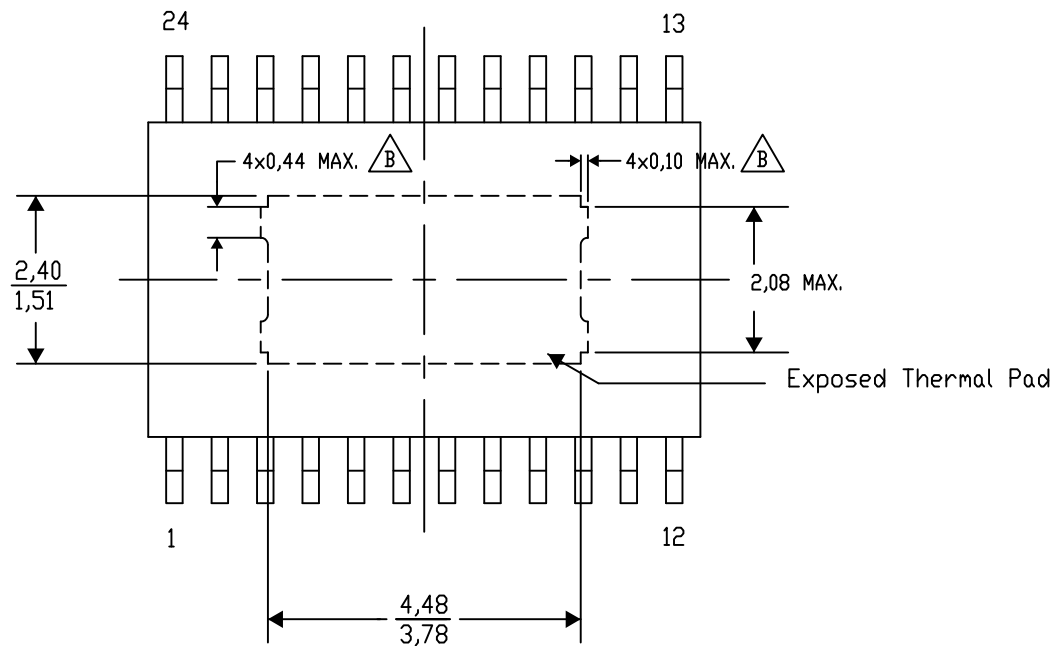

Top View

Exposed Thermal Pad Dimensions

4206332-42/AO 01/16

NOTE: A. All linear dimensions are in millimeters

 B. Exposed tie strap features may not be present.

PowerPAD is a trademark of Texas Instruments



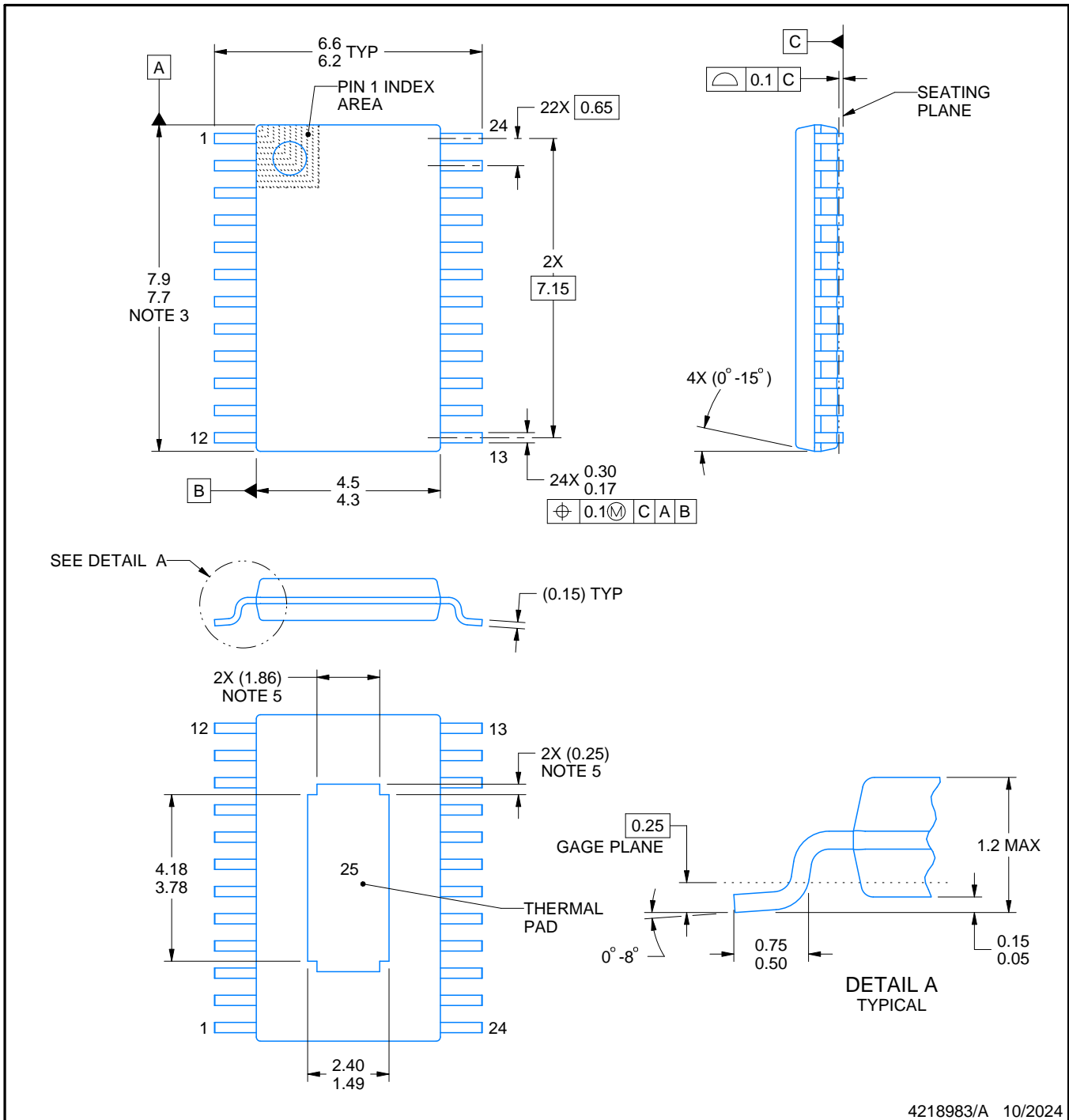
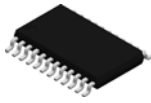

4218983/A 10/2024

NOTES:

PowerPAD is a trademark of Texas Instruments.

1. All linear dimensions are in millimeters. Any dimensions in parenthesis are for reference only. Dimensioning and tolerancing per ASME Y14.5M.
2. This drawing is subject to change without notice.
3. This dimension does not include mold flash, protrusions, or gate burrs. Mold flash, protrusions, or gate burrs shall not exceed 0.15 mm per side.
4. Reference JEDEC registration MO-153.
5. Features may differ or may not be present.

# EXAMPLE BOARD LAYOUT

PWP0024A

PowerPAD™ TSSOP - 1.2 mm max height

SMALL OUTLINE PACKAGE

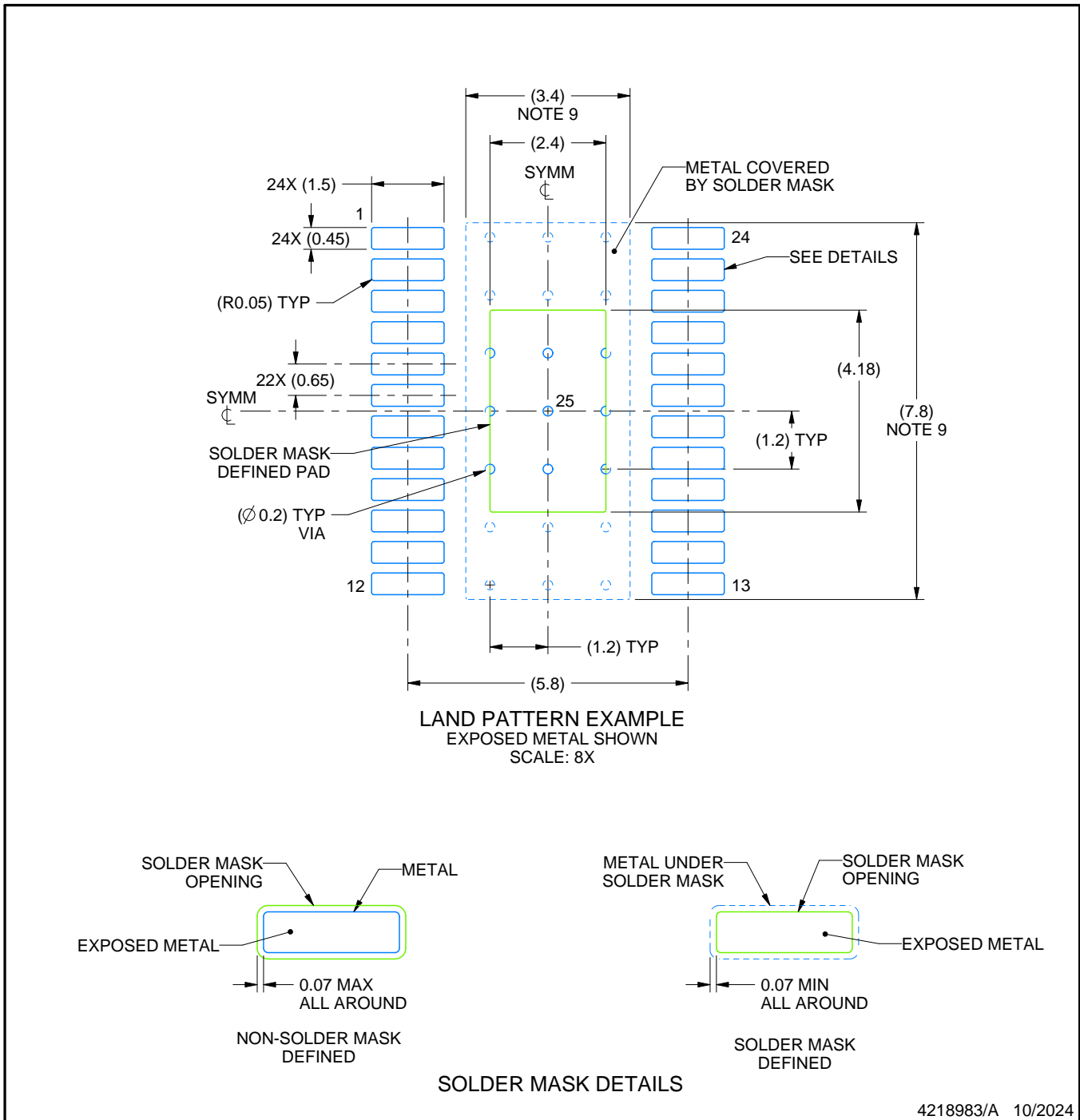

NOTES: (continued)

6. Publication IPC-7351 may have alternate designs.
7. Solder mask tolerances between and around signal pads can vary based on board fabrication site.
8. This package is designed to be soldered to a thermal pad on the board. For more information, see Texas Instruments literature numbers SLMA002 ([www.ti.com/lit/slma002](http://www.ti.com/lit/slma002)) and SLMA004 ([www.ti.com/lit/slma004](http://www.ti.com/lit/slma004)).
9. Size of metal pad may vary due to creepage requirement.
10. Vias are optional depending on application, refer to device data sheet. It is recommended that vias under paste be filled, plugged or tented.

# EXAMPLE STENCIL DESIGN

PWP0024A

PowerPAD™ TSSOP - 1.2 mm max height

SMALL OUTLINE PACKAGE

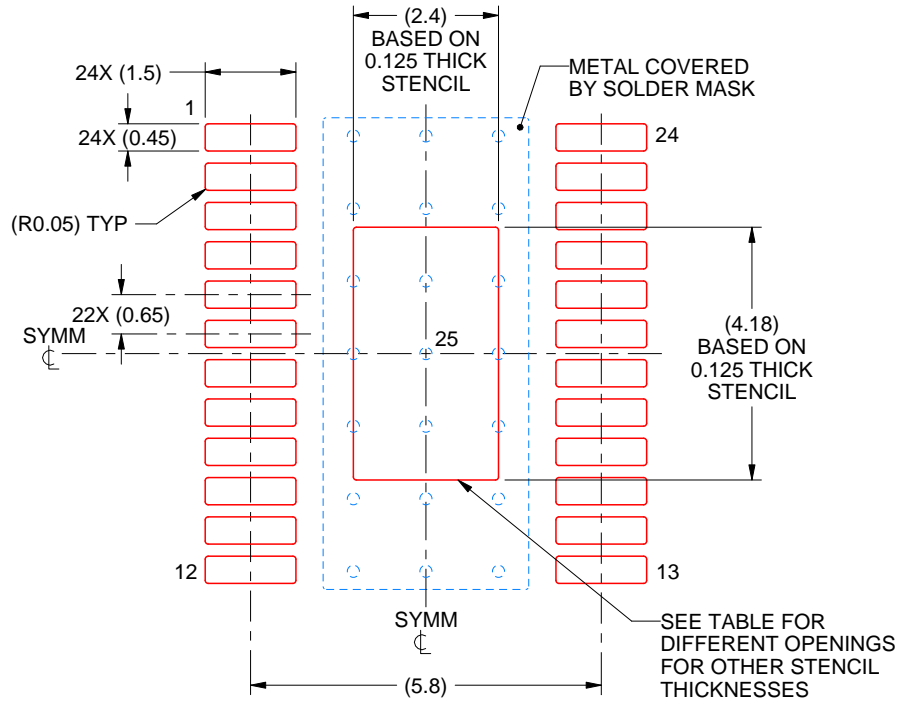

SOLDER PASTE EXAMPLE  
 BASED ON 0.125 mm THICK STENCIL  
 SCALE: 8X

STENCIL THICKNESS	SOLDER STENCIL OPENING
0.1	2.68 X 4.67
0.125	2.40 X 4.18 (SHOWN)
0.15	2.19 X 3.82
0.175	2.03 X 3.53

4218983/A 10/2024

NOTES: (continued)

- 11. Laser cutting apertures with trapezoidal walls and rounded corners may offer better paste release. IPC-7525 may have alternate design recommendations.
- 12. Board assembly site may have different recommendations for stencil design.

## IMPORTANT NOTICE AND DISCLAIMER

TI PROVIDES TECHNICAL AND RELIABILITY DATA (INCLUDING DATASHEETS), DESIGN RESOURCES (INCLUDING REFERENCE DESIGNS), APPLICATION OR OTHER DESIGN ADVICE, WEB TOOLS, SAFETY INFORMATION, AND OTHER RESOURCES "AS IS" AND WITH ALL FAULTS, AND DISCLAIMS ALL WARRANTIES, EXPRESS AND IMPLIED, INCLUDING WITHOUT LIMITATION ANY IMPLIED WARRANTIES OF MERCHANTABILITY, FITNESS FOR A PARTICULAR PURPOSE OR NON-INFRINGEMENT OF THIRD PARTY INTELLECTUAL PROPERTY RIGHTS.

These resources are intended for skilled developers designing with TI products. You are solely responsible for (1) selecting the appropriate TI products for your application, (2) designing, validating and testing your application, and (3) ensuring your application meets applicable standards, and any other safety, security, regulatory or other requirements.

These resources are subject to change without notice. TI grants you permission to use these resources only for development of an application that uses the TI products described in the resource. Other reproduction and display of these resources is prohibited. No license is granted to any other TI intellectual property right or to any third party intellectual property right. TI disclaims responsibility for, and you fully indemnify TI and its representatives against any claims, damages, costs, losses, and liabilities arising out of your use of these resources.

TI's products are provided subject to [TI's Terms of Sale](#), [TI's General Quality Guidelines](#), or other applicable terms available either on [ti.com](http://ti.com) or provided in conjunction with such TI products. TI's provision of these resources does not expand or otherwise alter TI's applicable warranties or warranty disclaimers for TI products. Unless TI explicitly designates a product as custom or customer-specified, TI products are standard, catalog, general purpose devices.

TI objects to and rejects any additional or different terms you may propose.

Copyright © 2025, Texas Instruments Incorporated

Last updated 10/2025