

# TPS7H2140-SEP Radiation-Tolerant 32-V, 160-mΩ Quad-Channel eFuse

## 1 Features

- Vendor item drawing available, [VID V62/23610](#)
- Total ionizing dose (TID) characterized to 30 krad(Si)
  - RLAT (radiation lot acceptance testing) to 20 krad(Si)
- Single-event effects (SEE) characterized
  - Single-event latch-up (SEL), single-event burnout (SEB), and single-event gate rupture (SEGR) immune to linear energy transfer (LET) of 43 MeV-cm<sup>2</sup>/mg
  - Single-event transient (SET) and single-event functional interrupt (SEFI) characterized to effective linear energy transfer (LET) of 43 MeV-cm<sup>2</sup>/mg
- Quad-channel 160-mΩ eFuse with full diagnostics and current-sense analog output
- Wide operating voltage 4.5 V to 32 V
- Ultra-low standby current < 500 nA
- High-accuracy current sense: ±15% when I<sub>LOAD</sub> ≥ 25 mA
- Adjustable current limit with external resistor (R<sub>CL</sub>), with accuracy of ±15% when I<sub>LOAD</sub> ≥ 500 mA
- Protection
  - Short-to-GND protection by current limit (internal or external)
  - Thermal shutdown with latch off option and thermal swing
  - Inductive load negative voltage clamp with optimized slew rate
  - Loss-of-GND and loss-of-power protection
- Diagnostics
  - Overcurrent and short-to-ground detection
  - Open-load and short-to-power detection
  - Global fault report for fast interrupt
- 28-pin thermally-enhanced PWP package
- Space Enhanced Plastic (SEP)
- Available in military (–55°C to 125°C) temp range

## 2 Applications

- [Satellite electrical power systems \(EPS\)](#)
- Space satellite power management and distribution
- Radiation-tolerant power tree applications
- Enables switching power rails for controlled power up and power down
- Solenoid driving

## 3 Description

The TPS7H2140-SEP device is a fully protected quad-channel eFuse with four integrated 160-mΩ NMOS power FETs.

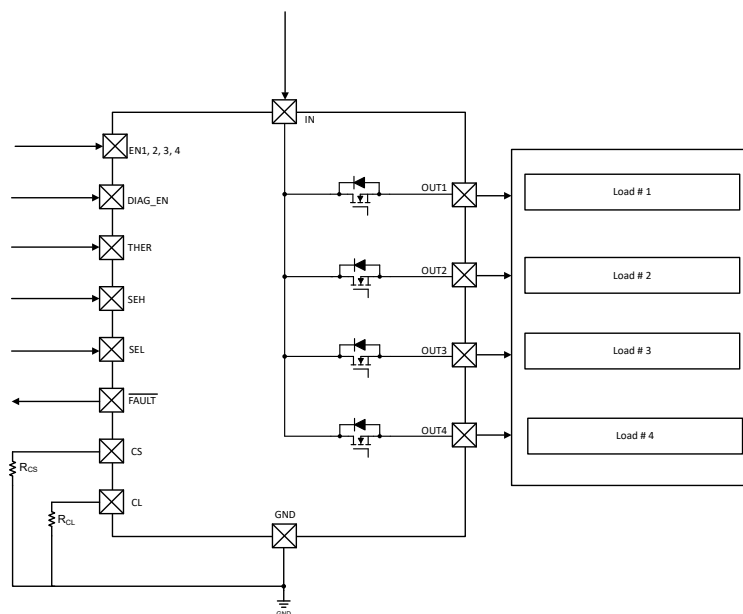
Full diagnostics and high-accuracy current sense enables intelligent control of the loads.

An external adjustable current limit improves the reliability of whole system by limiting the inrush or overload current.

### Device Information

PART NUMBER <sup>(1)</sup>	GRADE <sup>(2)</sup>	BODY SIZE <sup>(4)</sup>
TPS7H2140MPWPTSEP	SEP	HTSSOP (28) 6.4 mm × 9.7 mm Mass = 124 mg <sup>(3)</sup>
TPS7H2140EVM	Evaluation module	Evaluation board

- (1) For all available packages, see the orderable addendum at the end of the data sheet.
- (2) For additional information about part grade, view [SLYB235](#).
- (3) Mass is a nominal value.
- (4) The body size (length × width) is a nominal value and does not include pins.



**Typical Application Schematic**



## Table of Contents

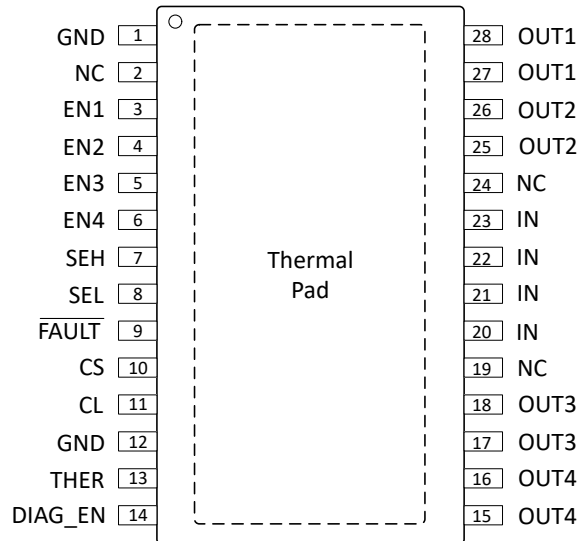
<b>1 Features</b> .....	1	8.3 Feature Description.....	13
<b>2 Applications</b> .....	1	8.4 Device Functional Modes.....	26
<b>3 Description</b> .....	1	<b>9 Application and Implementation</b> .....	28
<b>4 Revision History</b> .....	2	9.1 Application Information.....	28
<b>5 Pin Configuration and Functions</b> .....	3	9.2 Typical Application.....	28
<b>6 Specifications</b> .....	4	9.3 Power Supply Recommendations.....	30
6.1 Absolute Maximum Ratings.....	4	9.4 Layout.....	31
6.2 ESD Ratings.....	4	<b>10 Device and Documentation Support</b> .....	33
6.3 Recommended Operating Conditions.....	5	10.1 Documentation Support.....	33
6.4 Thermal Information.....	5	10.2 Receiving Notification of Documentation Updates..	33
6.5 Electrical Characteristics.....	5	10.3 Support Resources.....	33
6.6 Switching Characteristics.....	7	10.4 Trademarks.....	33
6.7 Typical Characteristics.....	8	10.5 Electrostatic Discharge Caution.....	33
<b>7 Parameter Measurement Information</b> .....	11	10.6 Glossary.....	33
<b>8 Detailed Description</b> .....	12	<b>11 Mechanical, Packaging, and Orderable Information</b> .....	33
8.1 Overview.....	12		
8.2 Functional Block Diagram.....	12		

## 4 Revision History

NOTE: Page numbers for previous revisions may differ from page numbers in the current version.

<b>Changes from Revision * (July 2023) to Revision A (October 2023)</b>	<b>Page</b>
• Changed document status from Advance Information to production data.....	1

## 5 Pin Configuration and Functions



**Figure 5-1. PWP Package  
28-Pin HTSSOP With Exposed Thermal Pad  
(Top View)**

**Table 5-1. Pin Functions**

PIN		I/O <sup>(1)</sup>	DESCRIPTION
NAME	NO.		
CL	11	O	Adjustable current limit. Connect to device GND if external current limit is not used.
CS	10	O	Current-sense output.
DIAG_EN	14	I	Enable-disable pin for diagnostics; internal pull-down.
FAULT	9	O	Global fault report with open-drain structure, ORed logic for quad-channel fault conditions.
GND	1, 12	—	Ground pin.
EN1	3	I	Input control for channel 1 activation; internal pull-down.
EN2	4	I	Input control for channel 2 activation; internal pull-down.
EN3	5	I	Input control for channel 3 activation; internal pull-down.
EN4	6	I	Input control for channel 4 activation; internal pull-down.
NC	2, 19, 24	—	No connect. This pin is not internally connected. It is recommended to connect this pin to GND to prevent charge buildup; however, this pin can also be left open or tied to any voltage between GND and IN.
SEH	7	I	CS channel-selection high bit; internal pull-down.
SEL	8	I	CS channel-selection low bit; internal pull-down.
THER	13	I	Thermal shutdown behavior control, latch off or auto-retry; internal pull-down.
OUT1	27, 28	O	Output of the channel 1 high side-switch, connected to the load.
OUT2	25, 26	O	Output of the channel 2 high side-switch, connected to the load.
OUT3	17, 18	O	Output of the channel 3 high side-switch, connected to the load.
OUT4	15, 16	O	Output of the channel 4 high side-switch, connected to the load.
IN	20, 21, 22, 23	I	Power supply.
Thermal pad	—	—	Connect to device GND or leave floating.

(1) I = Input, O = Other, — = Other

## 6 Specifications

### 6.1 Absolute Maximum Ratings

over operating free-air temperature range (unless otherwise noted) <sup>(1)</sup> <sup>(2)</sup>

		MIN	MAX	UNIT
Input voltage	IN (t < 400 ms)		48	V
	IN		35	
	Reverse polarity voltage <sup>(3)</sup>	-36		
	ENx, DIAG_EN, SEL, SEH, and THER	-0.3	7	
	FAULT	-0.3	7	
	CS	-2.7	7	
	CL	-0.3	7	
Input and output current	ENx, DIAG_EN, SEL, SEH, and THER pins	-10		mA
	GND (t < 120 s)	-100	250	
	FAULT	-30	10	
	CS		30	
	CL		6	
Input energy	Inductive load switch-off energy dissipation, single pulse, single channel <sup>(4)</sup>		40	mJ
Junction temperature	T <sub>J</sub>	-55	150	°C
Storage temperature	T <sub>stg</sub>	-65	150	

- (1) Operation outside the Absolute Maximum Ratings may cause permanent device damage. Absolute Maximum Ratings do not imply functional operation of the device at these or any other conditions beyond those listed under Recommended Operating Conditions. If used outside the Recommended Operating Conditions but within the Absolute Maximum Ratings, the device may not be fully functional, and this may affect device reliability, functionality, performance, and shorten the device lifetime.
- (2) All voltage values are with respect to GND.
- (3) Reverse polarity condition: time t < 60 s, reverse current < I<sub>R2</sub>, V<sub>ENx</sub> = 0 V, GND pin 1-kΩ resistor in parallel with diode.
- (4) Test condition: V<sub>IN</sub> = 13.5 V, L = 8 mH, R = 0 Ω, T<sub>J</sub> = 150°C. FR4 2s2p board, 2 × 70-μm Cu, 2 × 35-μm Cu. 600 mm<sup>2</sup> thermal pad copper area.

### 6.2 ESD Ratings

			VALUE	UNIT	
V <sub>(ESD)</sub>	Electrostatic discharge	Human body model (HBM), per ANSI/ESDA/JEDEC JS-001 <sup>(1)</sup>	IN and VOUTx with respect to GND	±4000	V
		Human body model (HBM), per ANSI/ESDA/JEDEC JS-001 <sup>(1)</sup>	All pins except IN and VOUTx	±2000	
		Charged device model (CDM), per ANSI/ESDA/JEDEC JS-002, all pins <sup>(2)</sup>	All pins	±750	

- (1) JEDEC document JEP155 states that 500-V HBM allows safe manufacturing with a standard ESD control process.
- (2) JEDEC document JEP157 states that 250-V CDM allows safe manufacturing with a standard ESD control process.

### 6.3 Recommended Operating Conditions

over operating free-air temperature range (unless otherwise noted) <sup>(1)</sup>

		MIN	MAX	UNIT
Input voltage	IN <sup>(1)</sup>	4.5	32	V
	ENx, DIAG_EN, SEL, SEH, and THER	0	5	
	FAULT	0	5	
Output current	OUTx <sup>(3)</sup>	0	1.35	A
Ambient temperature	T <sub>A</sub>	-55	125	°C

- (1) All voltage values are with respect to GND.  
(2) Transients up to the absolute maximum is allowed.  
(3) All channel on.

### 6.4 Thermal Information

THERMAL METRIC <sup>(1)</sup>		TPS7H2140-SEP	UNIT
		HTSSOP (PWP)	
		28 PINS	
R <sub>θJA</sub>	Junction-to-ambient thermal resistance	27	°C/W
R <sub>θJC(top)</sub>	Junction-to-case (top) thermal resistance	20.3	
R <sub>θJB</sub>	Junction-to-board thermal resistance	8	
ψ <sub>JT</sub>	Junction-to-top characterization parameter	0.2	
ψ <sub>JB</sub>	Junction-to-board characterization parameter	8	
R <sub>θJC(bot)</sub>	Junction-to-case (bottom) thermal resistance	1.1	

- (1) For more information about traditional and new thermal metrics, see the *IC Package Thermal Metrics* application report, [SPRA953](#).

### 6.5 Electrical Characteristics

over 4.5 V ≤ V<sub>IN</sub> ≤ 32 V, temperature range (-55°C ≤ T<sub>A</sub> ≤ 125°C), unless otherwise specified <sup>(1)</sup>

PARAMETER		TEST CONDITIONS	MIN	TYP	MAX	UNIT
<b>OPERATING VOLTAGE</b>						
IN <sub>UVLOR</sub>	Internal V <sub>IN</sub> UVLO rising		3.5	3.7	4	V
IN <sub>UVLOF</sub>	Internal V <sub>IN</sub> UVLO falling		3	3.2	3.4	
HYST <sub>IN-UVLO</sub>	Internal V <sub>IN</sub> UVLO hysteresis			0.5		
<b>OPERATING CURRENT</b>						
I <sub>Q</sub>	Quiescent current with diagnostics disabled	ENx = 5 V, DIAG_EN = 0 V, I <sub>OUTx</sub> = 0 A, current limit = 2 A, all channels on			7.0	mA
I <sub>Q_DIAG</sub>	Quiescent current with diagnostics enabled	ENx = DIAG_EN = 5 V, I <sub>OUTx</sub> = 0 A, current limit = 2 A, all channels on			6.2	
I <sub>SD</sub>	Shutdown current with diagnostics disabled	ENx = DIAG_EN = OUTx = THER = 0 V			0.5	μA
			T <sub>A</sub> =25°C		5	
I <sub>SD_DIAG</sub>	Shutdown current with diagnostic enabled	ENx = 0 V, DIAG_EN = 5 V, V <sub>IN</sub> - V <sub>OUTx</sub> < V <sub>OL_OFF</sub> , not in open-load mode			5	mA
t <sub>LOW_OFF</sub>	ENx signal low time during cycling	ENx from high to low, if elapsed time > t <sub>LOW_OFF</sub> , the device enters into standby mode	10	12.5	15	ms
I <sub>F</sub>	IN to OUTx forward leakage current	ENx = DIAG_EN = OUTx = 0			0.5	μA
			T <sub>A</sub> = 25°C			
		ENx = DIAG_EN = OUTx = 0			8	
			T <sub>A</sub> = 125°C			

## 6.5 Electrical Characteristics (continued)

 over  $4.5\text{ V} \leq V_{IN} \leq 32\text{ V}$ , temperature range  $(-55^\circ\text{C} \leq T_A \leq 125^\circ\text{C})$ , unless otherwise specified <sup>(1)</sup>

PARAMETER		TEST CONDITIONS		MIN	TYP	MAX	UNIT
<b>POWER STAGE</b>							
R <sub>ON</sub>	On-state resistance	T <sub>A</sub> = 25°C		165			mΩ
		T <sub>A</sub> = 125°C		280			
ΔR <sub>ON</sub>	Percentage Difference in On-state resistance between channels (R <sub>ON_CHX</sub> – R <sub>ON_CHY</sub> )	T <sub>A</sub> = 25°C		6%			
I <sub>CL_INTERNAL</sub>	Internal current limit	Internal current limit value, CL pin connected to GND		11			A
I <sub>CL_INTERNAL_TSD</sub>	Current limit during thermal shutdown	Internal current limit value under thermal shutdown		6.5			
I <sub>CL_TSD</sub>	Current limit during thermal shutdown	External current limit value under thermal shutdown. The percentage of the external current limit setting value		70%			
V <sub>DS_CLAMP</sub>	Source-to-drain body diode voltage			50	70		V
<b>OUTPUT DIODE CHARACTERISTICS</b>							
V <sub>F</sub>	Drain-source diode voltage	ENx = 0, I <sub>OUTX</sub> = –0.15 A.		0.3	0.7	0.9	V
I <sub>R1</sub>	Continuous reverse current from source to drain	t < 60 s, V <sub>IN</sub> = 24 V, ENx = 0 V. Single channel reversed current to supply		T <sub>A</sub> = 25°C		2.5	A
I <sub>R2</sub>	Continuous reverse current from source to drain	t < 60 s, V <sub>IN</sub> = 24 V, ENx = 0 V. GND pin 1-kΩ resistor in parallel with diode. Reverse-current condition, All channels reversed		T <sub>A</sub> = 25°C		2.0	
<b>LOGIC INPUT (ENx, DIAG_EN, SEL, SEH, THER)</b>							
V <sub>IH</sub>	Logic high-level voltage			2			V
V <sub>IL</sub>	Logic low-level voltage			0.8			
R <sub>PULL_DOWN</sub>	Logic-pin pulldown resistor	V <sub>IN</sub> = V <sub>DIAG_EN</sub> = 5 V		200	275	350	kΩ
		V <sub>IN</sub> = V <sub>ENx</sub> = V <sub>SEL</sub> = V <sub>SEH</sub> = V <sub>THER</sub> = 5 V		100	175	250	
<b>DIAGNOSTICS</b>							
I <sub>GND_LOSS</sub>	Output leakage current under GND loss condition			100			μA
V <sub>OL_OFF</sub>	Open load detection threshold	V <sub>ENx</sub> = 0 V, when V <sub>IN</sub> – V <sub>OUTX</sub> > V <sub>OL_OFF</sub> . Duration longer than t <sub>OL_OFF</sub> , then open load is detected, off state.		1.6	2.6		V
t <sub>OL_OFF</sub>	Open-load detection threshold deglitch time	V <sub>ENx</sub> = 0 V, when V <sub>IN</sub> – V <sub>OUTX</sub> > V <sub>OL_OFF</sub> . Duration longer than t <sub>OL_OFF</sub> , then open load is detected, off state		300	550	800	μs
I <sub>OL_OFF</sub>	Off-state output sink current	V <sub>ENx</sub> = 0 V, V <sub>DIAG_EN</sub> = 5 V, V <sub>IN</sub> – V <sub>OUTX</sub> = 24 V, open load		T <sub>A</sub> = 125°C		100	μA
V <sub>OL_FAULT</sub>	Fault low-output voltage	I <sub>FAULT</sub> = 2 mA		0.2			V
t <sub>CL_DEGLITCH</sub>	Deglitch time when current limit occurs	ENx = DIAG_EN = 5 V. The deglitch time from current limit event to FAULT = Low and V <sub>CS_FAULT</sub>		220			μs
T <sub>SD</sub>	Thermal shutdown threshold			160	175		°C
T <sub>SD_RST</sub>	Thermal shutdown status reset threshold			155			
T <sub>sw</sub>	Thermal swing shutdown threshold			60			
T <sub>HYS</sub>	Hysteresis for resetting the thermal shutdown or thermal swing			10			
<b>CURRENT SENSE AND CURRENT LIMIT</b>							
K <sub>CS</sub>	Current sense ratio			300			
K <sub>CL</sub>	Current limit ratio			2500			
V <sub>CL_TH</sub>	Current limit internal threshold voltage <sup>(3)</sup>			0.8			V
dK <sub>CS</sub> / K <sub>CS</sub>	Current sense accuracy, (I <sub>CS</sub> × K <sub>CS</sub> – I <sub>OUT</sub> ) / I <sub>OUT</sub> × 100	V <sub>IN</sub> = 13.5 V, I <sub>OUTX</sub> ≥ 5 mA		–65%	65%		
dK <sub>CS</sub> / K <sub>CS</sub>		V <sub>IN</sub> = 13.5 V, I <sub>OUTX</sub> ≥ 25 mA		–15%	15%		
dK <sub>CS</sub> / K <sub>CS</sub>		V <sub>IN</sub> = 13.5 V, I <sub>OUTX</sub> ≥ 50 mA		–8%	8%		
dK <sub>CS</sub> / K <sub>CS</sub>		V <sub>IN</sub> = 13.5 V, I <sub>OUTX</sub> ≥ 100 mA		–4%	4%		

## 6.5 Electrical Characteristics (continued)

over  $4.5\text{ V} \leq V_{IN} \leq 32\text{ V}$ , temperature range  $(-55^\circ\text{C} \leq T_A \leq 125^\circ\text{C})$ , unless otherwise specified <sup>(1)</sup>

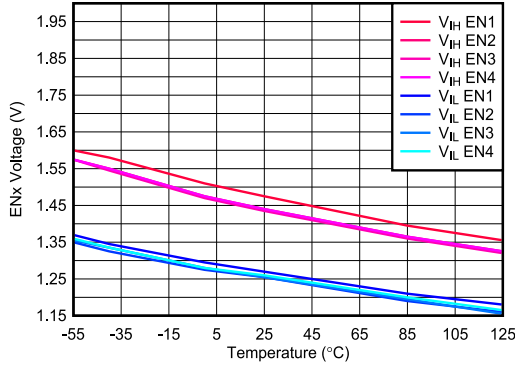
PARAMETER		TEST CONDITIONS	MIN	TYP	MAX	UNIT
dK <sub>CL</sub> / K <sub>CL</sub>	External current limit accuracy, $(I_{OUTX} - I_{CL} \times K_{CL}) \times 100 / (I_{CL} \times K_{CL})$	$V_{IN} = 13.5\text{ V}$ , $I_{LIMIT} \geq 250\text{ mA}$	-20%		20%	
		$V_{IN} = 13.5\text{ V}$ , $2\text{ A} \leq I_{LIMIT} \leq 4\text{ A}$	-15%		15%	
V <sub>CS_LINEAR</sub>	Current-sense voltage linear range	$V_{IN} \geq 6.5\text{ V}$	0		4	V
		$5\text{ V} \leq V_{IN} < 6.5\text{ V}$	0		$V_{IN} - 2.5$	
I <sub>OUTX_LINEAR</sub>	Output-current linear range	$V_{IN} \geq 6.5\text{ V}$ , $V_{CS\_LINEAR} \leq 4\text{ V}$	0		2.5	A
		$5\text{ V} \leq V_{IN} < 6.5\text{ V}$ , $V_{CS\_LINEAR} \leq V_{IN} - 2.5\text{ V}$	0		2.5	
V <sub>CS_FAULT</sub>	Current sense pin output voltage	$V_{IN} \geq 7\text{ V}$ , FAULT mode	4.5		6.5	V
		$5\text{ V} \leq V_{IN} < 7\text{ V}$ , FAULT mode	Min( $V_{IN} - 2.3$ , 4.5)		6.5	
I <sub>CS_FAULT</sub>	Current-sense pin output current available in fault mode	$V_{CS} = 4.5\text{ V}$ , $V_{IN} > 7\text{ V}$	15			mA
I <sub>CS_LEAK</sub>	Current-sense leakage current in disabled mode	$V_{DIAG\_EN} = 0\text{ V}$				$T_A = 125^\circ\text{C}$ 0.5 μA

- (1) All voltage values are with respect to GND.  
(2) V<sub>CL\_TH</sub> tolerance is included in the dK<sub>CL</sub> / K<sub>CL</sub> tolerance.

## 6.6 Switching Characteristics

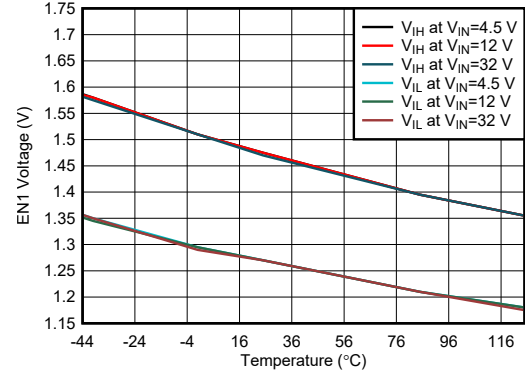
PARAMETER		TEST CONDITIONS	MIN	TYP	MAX	UNIT
<b>POWER STAGE</b>						
t <sub>ON</sub>	Turn-on delay time	$V_{IN} = 13.5\text{ V}$ , $V_{DIAG\_EN} = 5\text{ V}$ , $I_{OUTX} = 500\text{ mA}$ , from ENx rising edge to 10% of V <sub>OUTX</sub>	20	50	90	μs
t <sub>OFF</sub>	Turn-off delay time	$V_{IN} = 13.5\text{ V}$ , $V_{DIAG\_EN} = 5\text{ V}$ , $I_{OUTX} = 500\text{ mA}$ , from ENx falling edge to 90% of V <sub>OUTX</sub>	20	50	90	
t <sub>RISE</sub>	Channel turn-on time	$V_{IN} = 13.5\text{ V}$ , $V_{DIAG\_EN} = 5\text{ V}$ , $I_{OUTX} = 500\text{ mA}$ , from 50% of ENx to 90% of V <sub>OUTX</sub>	66	88	125	
t <sub>FALL</sub>	Channel turn-off time	$V_{IN} = 13.5\text{ V}$ , $V_{DIAG\_EN} = 5\text{ V}$ , $I_{OUTX} = 500\text{ mA}$ , from 50% of ENx to 10% of V <sub>OUTX</sub>	66	88	125	
t <sub>MATCH</sub>	t <sub>RISE</sub> - t <sub>FALL</sub>	$V_{IN} = 13.5\text{ V}$ , $I_{OUT} = 500\text{ mA}$ . t <sub>RISE</sub> is the ENx rising edge to V <sub>OUTX</sub> = 90%. t <sub>FALL</sub> is the ENx falling edge to V <sub>OUTX</sub> = 10%.	-50		50	
SR <sub>ON</sub>	Turn-on slew rate	$V_{IN} = 13.5\text{ V}$ , $V_{DIAG\_EN} = 5\text{ V}$ , $I_{OUTX} = 500\text{ mA}$ , from ENx rising edge to 10% of V <sub>OUTX</sub>	0.1	0.3	0.55	V/μs
SR <sub>OFF</sub>	Turn-off slew rate	$V_{IN} = 13.5\text{ V}$ , $V_{DIAG\_EN} = 5\text{ V}$ , $I_{OUTX} = 500\text{ mA}$ , from ENx falling edge to 90% of V <sub>OUTX</sub>	0.1	0.3	0.55	
<b>CURRENT SENSE</b>						
t <sub>CS_OFF1</sub>	CS settling time from DIAG_EN disabled	$V_{IN} = 13.5\text{ V}$ , $V_{ENx} = 5\text{ V}$ , $I_{OUTX} = 500\text{ mA}$ . Current Limit = 2 A. From V <sub>DIAG_EN</sub> falling edge to 10% of V <sub>CS</sub> .			20	μs
t <sub>CS_ON1</sub>	CS settling time from DIAG_EN enabled	$V_{IN} = 13.5\text{ V}$ , $V_{ENx} = 5\text{ V}$ , $I_{OUTX} = 500\text{ mA}$ . Current Limit = 2 A. From V <sub>DIAG_EN</sub> rising edge to 90% of V <sub>CS</sub> .			20	
t <sub>CS_OFF2</sub>	CS settling time from IN falling edge	$V_{IN} = 13.5\text{ V}$ , $V_{ENx} = 5\text{ V}$ , $I_{OUTX} = 500\text{ mA}$ . Current Limit = 2 A. From V <sub>ENx</sub> falling edge to 10% of V <sub>CS</sub> .	30		100	
t <sub>CS_ON2</sub>	CS settling time from IN rising edge	$V_{IN} = 13.5\text{ V}$ , $V_{ENx} = 5\text{ V}$ , $I_{OUTX} = 500\text{ mA}$ . Current Limit = 2 A. From V <sub>ENx</sub> rising edge to 90% of V <sub>CS</sub> .	50		150	
t <sub>MUX</sub>	Multi-sense transition delay from channel to channel	$V_{DIAG\_EN} = 5\text{ V}$ , current sense output delay when multi-sense pins SEL and SEH transition from channel to channel			50	

## 6.7 Typical Characteristics

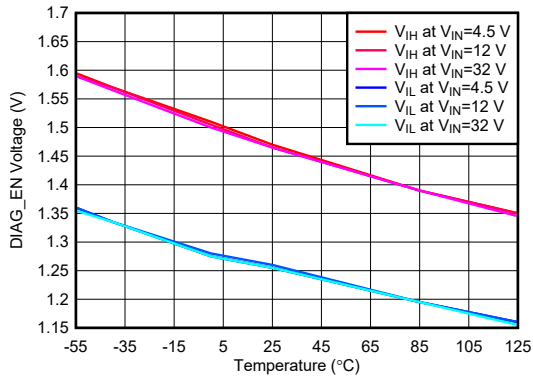


$V_{IN} = 12\text{ V}$

**Figure 6-1. ENx Voltage Threshold**

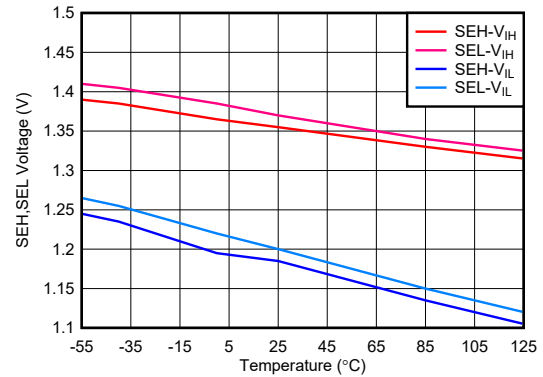


**Figure 6-2. EN1 Voltage Threshold vs  $V_{IN}$**



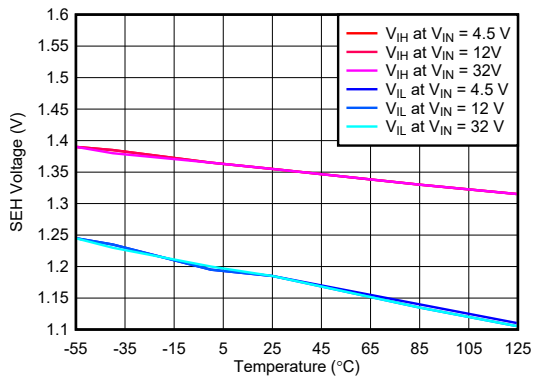
$V_{IN} = 12\text{ V}$

**Figure 6-3. DIAG\_EN Voltage Threshold**

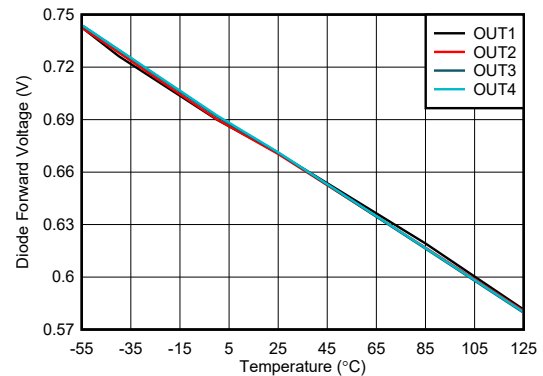


$V_{IN} = 12\text{ V}$

**Figure 6-4. SEH,SEL Voltage Threshold**



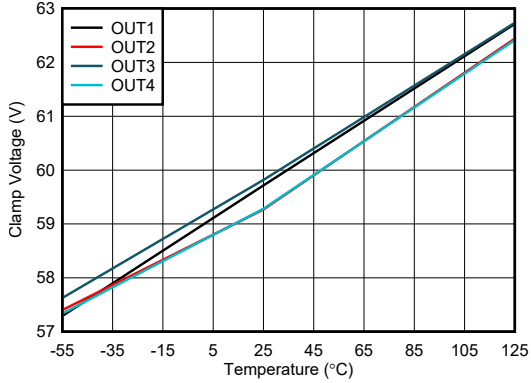
**Figure 6-5. SEH Voltage Threshold vs  $V_{IN}$**



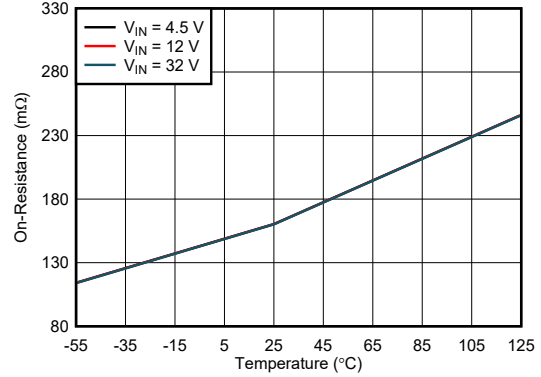
$I_{Fx} = 150\text{ mA}$

**Figure 6-6. Body-Diode Forward Voltage**

### 6.7 Typical Characteristics (continued)

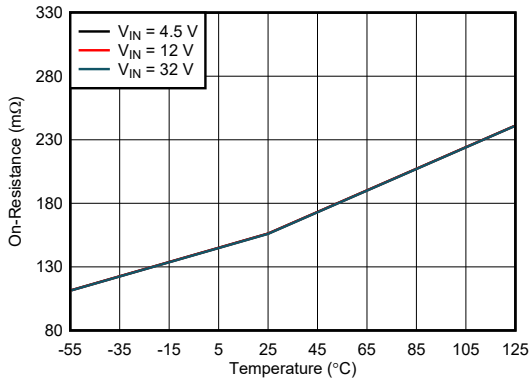


**Figure 6-7. Drain-to-Source Clamp Voltage**



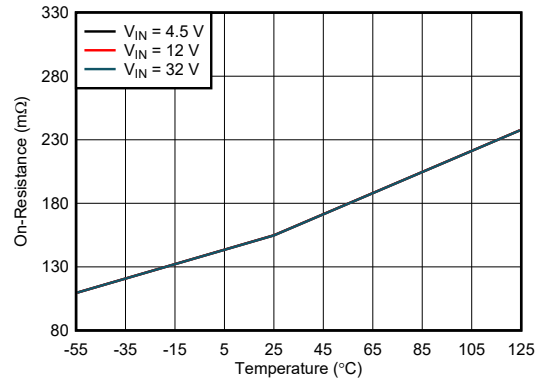
$I_{OUT1} = 490 \text{ mA}$

**Figure 6-8. Channel-1 FET On-Resistance**



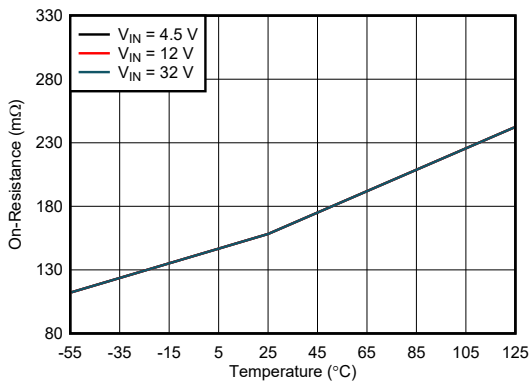
$I_{OUT2} = 490 \text{ mA}$

**Figure 6-9. Channel-2 FET On-Resistance**



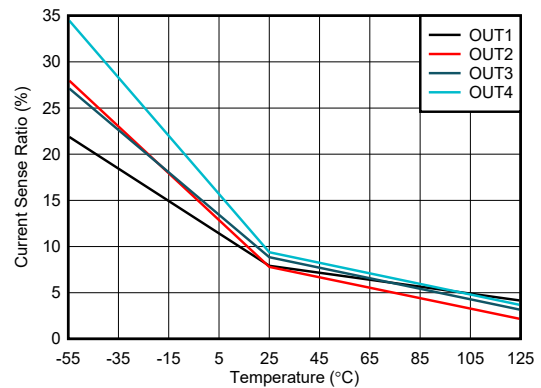
$I_{OUT3} = 490 \text{ mA}$

**Figure 6-10. Channel-3 FET On-Resistance**



$I_{OUT4} = 490 \text{ mA}$

**Figure 6-11. Channel-4 FET On-Resistance**



**Figure 6-12. Current-Sense Ratio at 5 mA**

### 6.7 Typical Characteristics (continued)

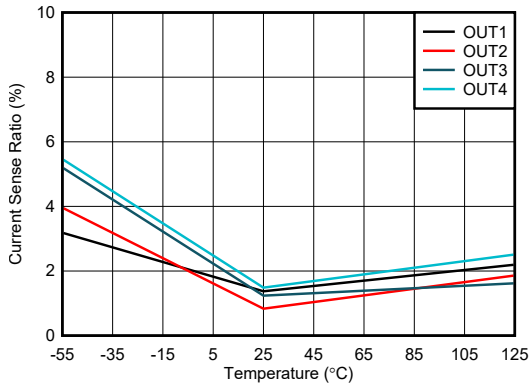


Figure 6-13. Current-Sense Ratio at 25 mA

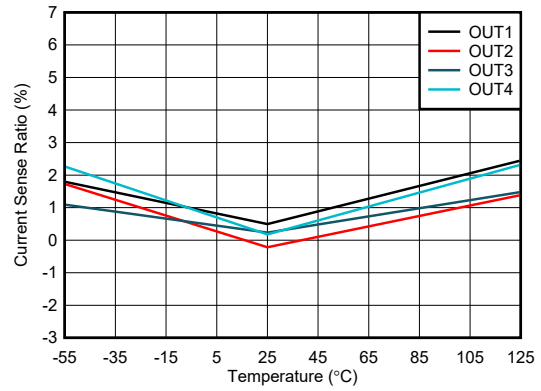


Figure 6-14. Current-Sense Ratio at 50 mA

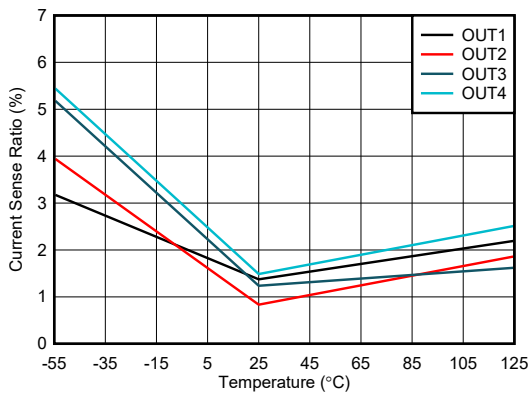


Figure 6-15. Current-Sense Ratio at 100 mA

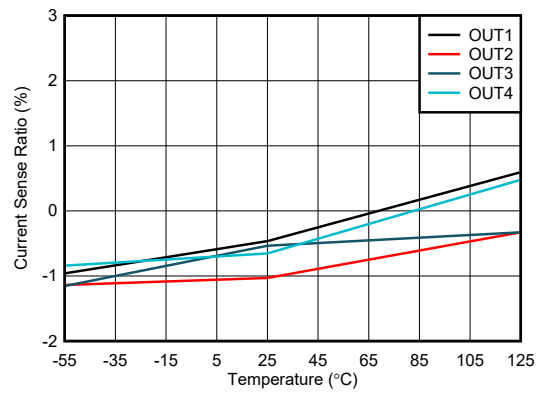
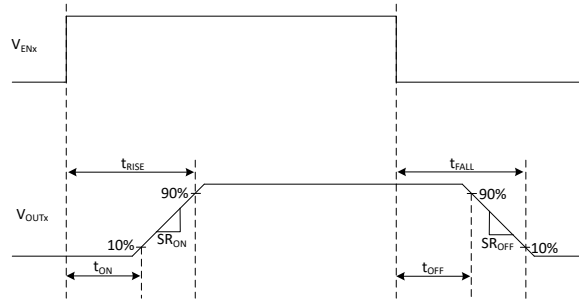
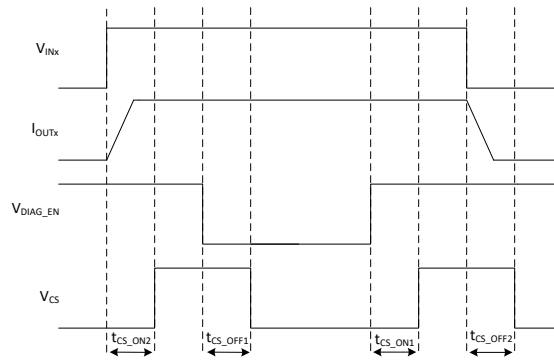


Figure 6-16. Current-Sense Ratio at 500 mA

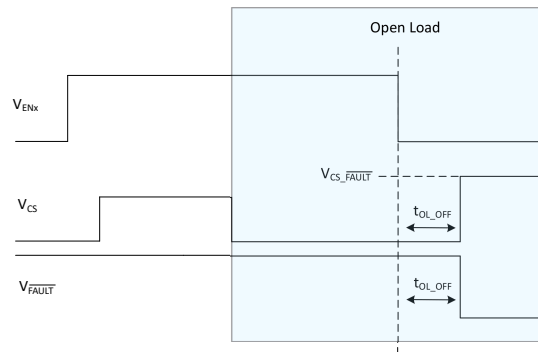
## 7 Parameter Measurement Information



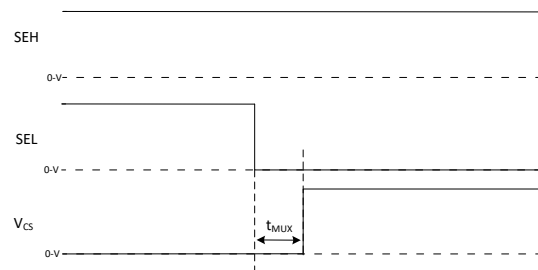
**Figure 7-1. Output Delay Characteristics**



**Figure 7-2. CS Delay Characteristics**



**Figure 7-3. Open-Load Blanking-Time Characteristics**



**Figure 7-4. Multi-sense Transition Delay**

## 8 Detailed Description

### 8.1 Overview

The TPS7H2140-SEP device is a eFuse, with internal charge pump and quad-channel integrated NMOS power FETs. Full diagnostics and high-accuracy current-sense features enable intelligent control of the load. The adjustable current-limit function greatly improves the reliability of whole system. The device includes diagnostic reporting, which includes an global open-drain digital output and the current-sense analog output.

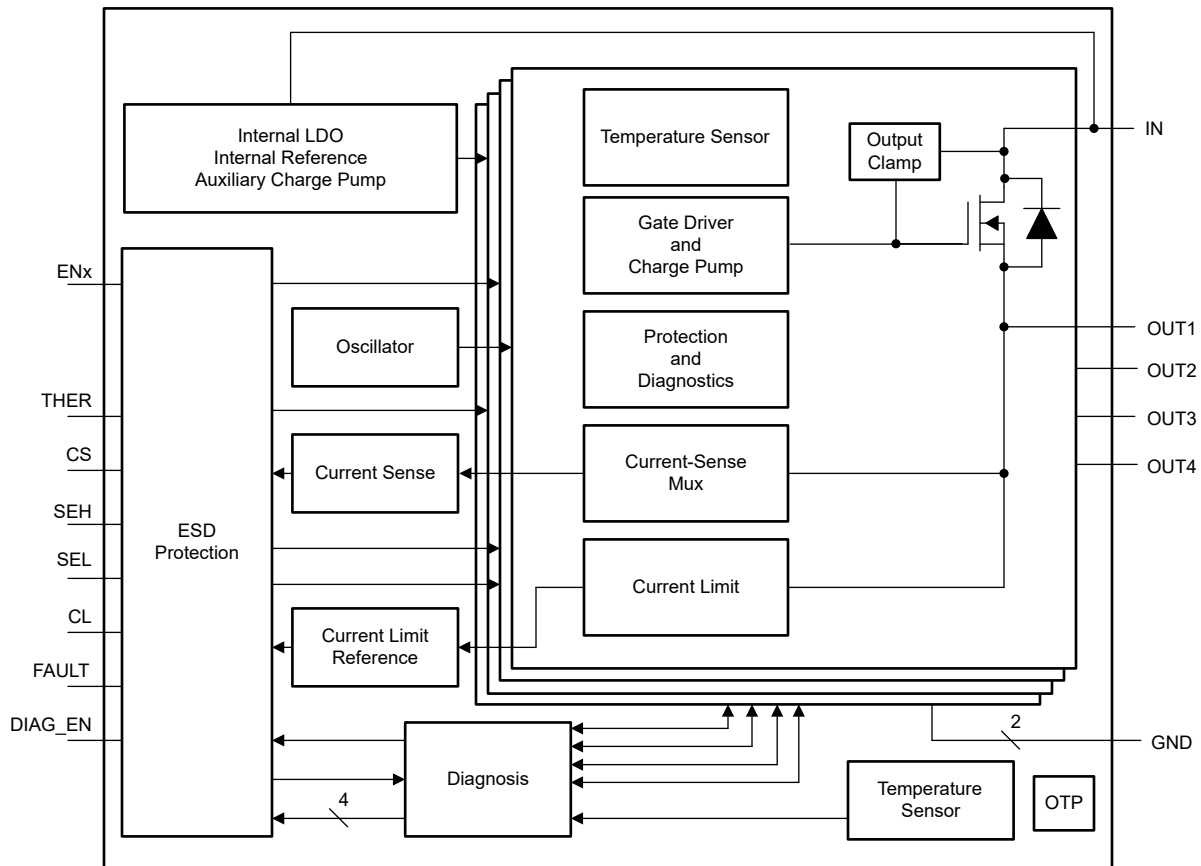
High-accuracy current sense makes the diagnostics more accurate without further calibration. One integrated current mirror can source  $1 / K_{CS}$  of the load current. The mirrored current flows into the CS-pin resistor to become a voltage signal.  $K_{CS}$  is a constant value (300) across temperature and supply voltage. A wide linear region from 0 V to 4 V allows a better real-time load-current monitoring. The CS pin can also report a fault with pullup voltage of  $V_{CS\_FAULT}$ .

The external high-accuracy current limit allows setting the current-limit value by applications. When overcurrent occurs, the device improves system reliability by clamping the inrush current effectively. The device can also save system area by reducing the size of PCB traces and connectors, and the capacity of the preceding power stage. Additional, the device also implements an internal current limit ( $I_{CL\_INTERNAL}$ ) with a fixed value, between 8 to 14 A.

For inductive loads (relays, solenoids, valves), the device implements an active clamp between drain and source to protect itself. During the inductive switching-off cycle, both the energy of the power supply and the load are dissipated on the high-side switch. The device also optimizes the switching-off slew rate when the clamp is active, which helps the system design by keeping the effects of transient power and EMI to a minimum.

The TPS7H2140-SEP device is a eFuse for a wide variety of resistive, inductive, and capacitive loads, including: relays, solenoids, heaters, and sub-modules.

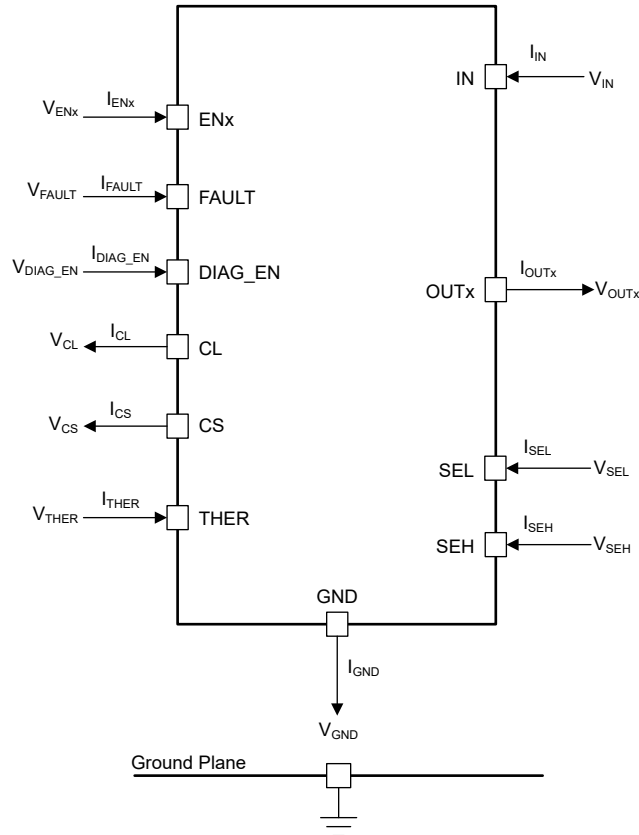
### 8.2 Functional Block Diagram



## 8.3 Feature Description

### 8.3.1 Pin Current and Voltage Conventions

For reference purposes throughout the data sheet, current directions on their respective pins are as shown by the arrows in [Figure 8-1](#). All voltages are measured relative to the ground plane.



**Figure 8-1. Voltage and Current Conventions**

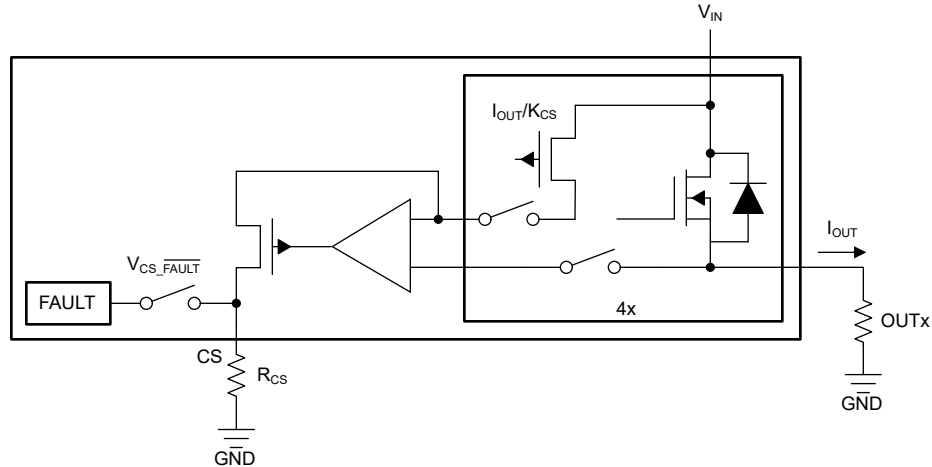
### 8.3.2 Accurate Current Sense

High-accuracy current sense is implemented in the TPS7H2140-SEP. It allows a better real-time monitoring effect and more-accurate diagnostics without further calibration.

The integrated current mirror sources a ratio of the load current as:  $1 / K_{CS}$  (where:  $K_{CS} = 300$ ). This mirrored current flows into the external current sense resistor to become a voltage signal. The current mirror is shared by the four channels. Channel selection is accomplished by using the multiplexer digital inputs (SEL and SEH).  $I_{CS}$  can be calculated using [Equation 1](#).

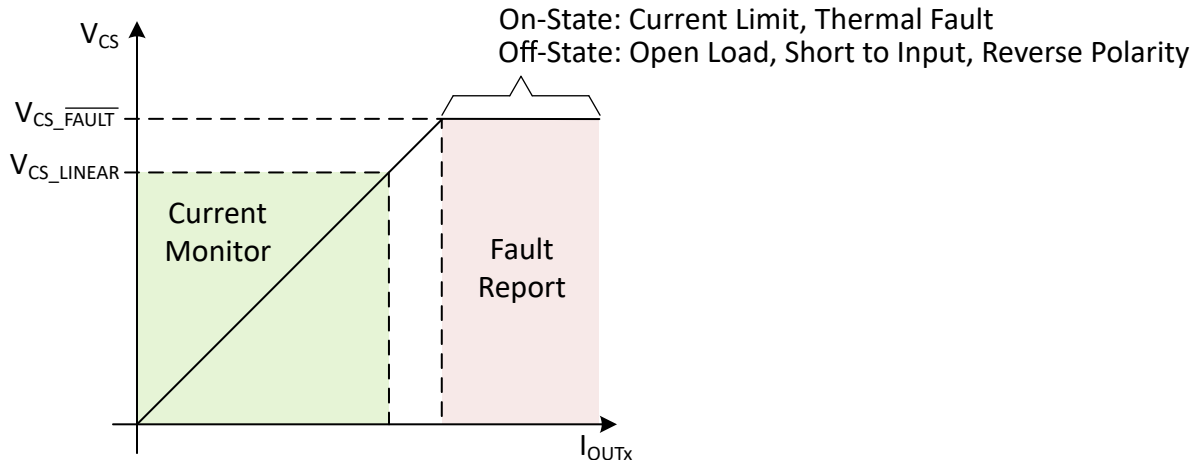
$$I_{CS} = \frac{I_{OUTx}}{K_{CS}} = \frac{I_{OUTx}}{300} \quad (1)$$

$K_{CS}$  is the ratio of the output current and the sense current (CS). It is a constant value across the temperature and supply voltage (IN). Each device is calibrated accurately during production, so post-calibration is not required. See [Figure 8-2](#) for more details.



**Figure 8-2. Current-Sense Block Diagram**

When a fault occurs, the CS pin also works as a fault report with a pullup voltage of  $V_{CS\_FAULT}$ . During a fault the maximum available current in CS is  $I_{CS\_FAULT}$  (15 mA). See [Figure 8-3](#) for more details.



**Figure 8-3. Current-Sense Output-Voltage Curve**

Use [Equation 2](#) to calculate  $R_{CS}$ .

$$R_{CS} = \frac{V_{CS}}{I_{CS}} = \frac{V_{CS} \times K_{CS}}{I_{OUTx}} \quad (2)$$

Take the following points into consideration when calculating  $R_{CS}$ .

- Ensure  $V_{CS}$  is within the current-sense linear region ( $V_{CS\_LINEAR}$ ,  $I_{OUTx\_LINEAR}$ ) across the full range of the load current. Check  $R_{CS}$  with [Equation 3](#).

$$R_{CS} = \frac{V_{CS}}{I_{CS}} \leq \frac{V_{CS\_LINEAR(MAX)} \times K_{CS}}{I_{OUTx(MAX)}} \quad (3)$$

- In fault mode, ensure  $I_{CS}$  is within the source capacity of the CS pin ( $I_{CS\_FAULT}$ ). Check  $R_{CS}$  with [Equation 4](#).

$$R_{CS} = \frac{V_{CS}}{I_{CS}} \geq \frac{V_{CS\_FAULT(MAX)}}{I_{CS\_FAULT(MIN)}} \quad (4)$$

### 8.3.3 Adjustable Current Limit

A high-accuracy current limit allows high reliability of the design. It protects the load and the power supply from overstressing during short-circuit-to-GND or power-up conditions. The current limit can also save system cost by reducing the size of PCB traces and connectors, and the capacity of the preceding power stage.

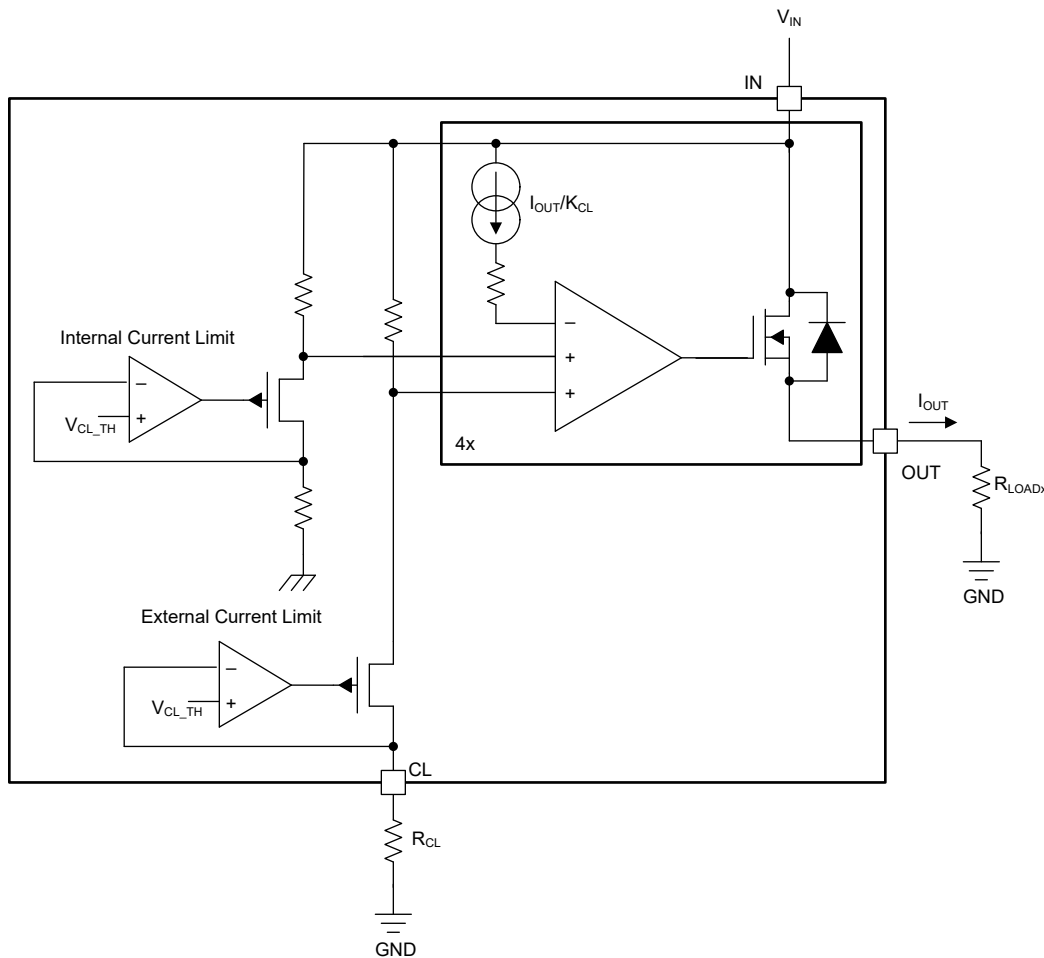
When a current-limit threshold is hit, a closed loop activates immediately. The output current is clamped at the set value, and a fault is reported out. The device heats up due to the high power dissipation on the power FET. If thermal shutdown occurs, the current limit is set to  $I_{CL\_TSD}$  (if set externally) or  $I_{CL\_INTERNAL\_TSD}$  (when using internal) to reduce the power dissipation on the power FET. See Figure 8-4 for more details.

The device has two current-limit thresholds.

- **Internal current limit** – The internal current limit is fixed at  $I_{CL\_INTERNAL}$ , typically 11 A. Tie the CL pin directly to the device GND for large-transient-current applications.
- **External adjustable current limit** – An external resistor is used to set the current-limit threshold. Use the Equation 5 and Equation 6 to calculate the  $R_{CL}$ .  $V_{CL\_TH}$  (0.8 V) is the internal band-gap voltage.  $K_{CL}$  (2500) is the ratio of the output current and the current-limit set value. It is constant across the temperature and supply voltage. The external adjustable current limit allows the flexibility to set the current limit value by applications.

$$I_{CL} = \frac{V_{CL\_TH}}{R_{CL}} = \frac{I_{OUT}}{K_{CL}} \tag{5}$$

$$R_{CL} = \frac{V_{CL\_TH} \times K_{CL}}{I_{OUT}} \tag{6}$$



**Figure 8-4. Current-Limit Block Diagram**

Note that if using a GND network which causes a level shift between the device GND and board GND, the CL pin must be connected with device GND.

For better protection from a hard short-to-GND condition (when the ENx pins are enabled, a short to GND occurs suddenly), the device implements a fast-trip protection to turn off the related channel before the current-limit closed loop is set up. The fast-trip response time is less than 1  $\mu$ s, typically. With this fast response, the device can achieve better inrush current-suppression performance.

### 8.3.4 Inductive-Load Switching-Off Clamp

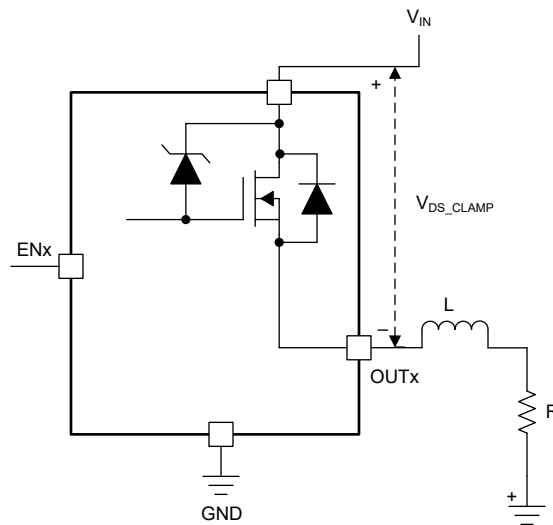
When switching an inductive load off, the inductive reactance tends to pull the output voltage negative. Excessive negative voltage could cause the power FET to break down. To protect the power FET, an internal clamp between drain and source is internally implemented, namely  $V_{DS\_CLAMP}$ .

$$V_{DS\_CLAMP} = V_{IN} - V_{OUTx} \quad (7)$$

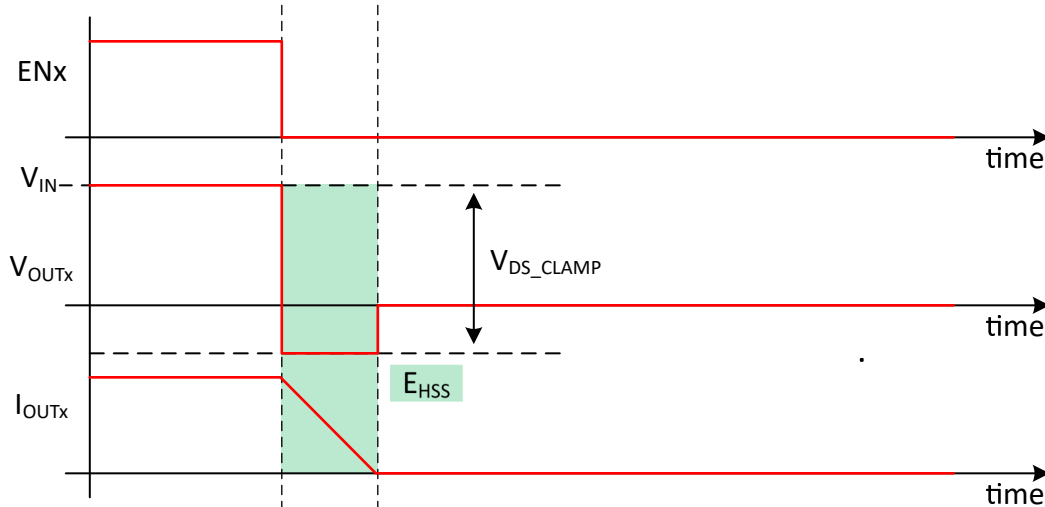
During the period of demagnetization ( $t_{decay}$ ), the power FET is turned on for inductance-energy dissipation. The total energy is dissipated in the high-side switch ( $E_{HSS}$ ). Total energy includes the energy of the power supply ( $E_{IN}$ ) and the energy of the load ( $E_{LOAD}$ ). If resistance is in series with inductance, some of the load energy is dissipated on the resistance ( $E_R$ ) and the inductor itself ( $E_L$ ).

$$E_{HSS} = E_{IN} + E_{LOAD} = E_{IN} + E_L + E_R \quad (8)$$

When an inductive load switches off,  $E_{HSS}$  causes high thermal stressing on the device. The upper limit of the power dissipation depends on the device intrinsic capacity, ambient temperature, and board dissipation condition.



**Figure 8-5. Drain-to-Source Clamping Structure**



**Figure 8-6. Inductive Load Switching-Off Diagram**

From the perspective of the high-side switch,  $E_{HSS}$  equals the integration value during the demagnetization period.

$$E_{HSSx} = \int_0^{t_{DECAYx}} V_{DS\_CLAMP} \times I_{OUTx}(t) dt \quad (9)$$

$$t_{DECAYx} = \frac{L}{R} \times \ln\left(\frac{R \times I_{OUT(MAX)} + |V_{OUT}|}{|V_{OUT}|}\right) \quad (10)$$

$$E_{HSSx} = L \times \frac{V_{IN} + |V_{OUT}|}{R^2} \times \left\{ (R \times I_{OUT(MAX)}) - \left[ |V_{OUT}| \times \ln\left(\frac{R \times I_{OUT(MAX)} + |V_{OUT}|}{|V_{OUT}|}\right) \right] \right\} \quad (11)$$

When R approximately equals 0,  $E_{HSS}$  can be given simply as:

$$E_{HSSx} = \frac{1}{2} \times L \times I_{OUT(MAX)}^2 \times \left[ \frac{(V_{IN} + |V_{OUT}|)}{|V_{OUT}|} \right] \quad (12)$$

Figure 8-7 is a waveform of the device driving an inductive load and dissipating 40 mJ of energy across the NMOS pass-element (across IN and OUT1) during the inductive kick-back. The energy was controlled by turning off the channel # 1 at 2.8 (at  $I_{OUT1}$ ).

The displayed signal definitions are shown in [Scope Signals Description](#)

**Table 8-1. Scope Signals Description**

Channel #	Name of the Signal	Signal Color
1	$V_{EN1}$	Blue
2	$V_{IN}$	Red
3	$V_{OUT1}$	Green
4	$I_{OUT1}$	Magenta
Math	$E_{HSS1}$	Cyan

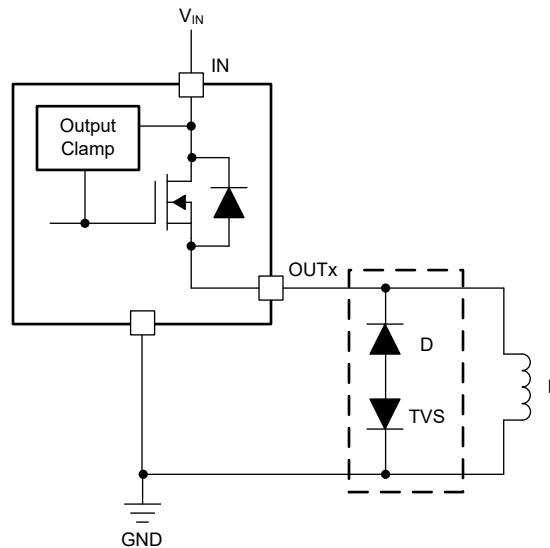
The device also optimizes the switching-off slew rate when the clamp is active. This optimization can help the system design by keeping the effects of transient power and EMI to a minimum.



**Figure 8-7. Inductive Load Switching-Off Waveform of 40mJ**

A. The nominal inductor value use for this waveform is 8mH.

Note that for PWM-controlled inductive loads, it is recommended to add the external freewheeling circuitry shown in [Figure 8-8](#) to protect the device from repetitive power stressing. TVS is used to achieve the fast decay. See [Figure 8-8](#) for more details.



**Figure 8-8. Protection With External Circuitry**

### 8.3.5 Fault Detection and Reporting

#### 8.3.5.1 Diagnostic Enable Function

The DIAG\_EN pin enables or disables the diagnostic functions. If multiple devices are used, but the ADC resource is limited in the house-keeping microcontroller, the MCU can use GPIOs to set DIAG\_EN high to

enable the diagnostics of one device while disabling the diagnostics of the other devices by setting DIAG\_EN low. In addition, the device can keep the power consumption to a minimum by setting DIAG\_EN and ENx low.

### 8.3.5.2 Multiplexing of Current Sense

SEL and SEH are the multiplexer selector high and low digital inputs. The multiplexer controls the channel selection for the current-sense function. As this function is shared among all four channels, only one at a time can be observed. See [Table 8-2](#) for more details.

**Table 8-2. Diagnosis Configuration Table**

DIAG_EN <sup>(1)</sup>	ENx <sup>(1)</sup>	SEH <sup>(1)</sup>	SEL <sup>(1)</sup>	CS ACTIVATED CHANNEL	CS, FAULT	PROTECTIONS AND DIAGNOSTICS
L	H	—	—	—	High impedance	Diagnostics disabled, full protection
	L					Diagnostics disabled, no protection
H	—	0	0	Channel # 1	See <a href="#">Table 8-3</a>	See <a href="#">Table 8-3</a>
		0	1	Channel # 2		
		1	0	Channel # 3		
		1	1	Channel # 4		

(1) L = 0 = logical zero (false), H = 1 = logical one (true), — = don't care

### 8.3.5.3 Fault Table

[Table 8-3](#) applies when the DIAG\_EN pin is enabled.

**Table 8-3. Fault Table**

CONDITIONS	ENx <sup>(2)</sup>	OUTx <sup>(2)</sup>	THER <sup>(2)</sup>	CRITERION <sup>(2)</sup>	CS	FAULT	FAULT RECOVERY
Normal	L	L	—	—	0	H	—
	H	H	—	—	In linear region	H	—
Overload, short to ground	H	L	—	Current limit triggered	V <sub>CS_FAULT</sub>	L	Auto
Open load <sup>(1)</sup> , short to power, reverse polarity	L	H	—	$V_{IN} - V_{OUTx} < V_{OL\_OFF}$	V <sub>CS_FAULT</sub>	L	Auto
Thermal shutdown	H	—	L	T <sub>SD</sub> triggered	V <sub>CS_FAULT</sub>	L	Output auto-retry. Fault recovers when T <sub>J</sub> < T <sub>(SD,rst)</sub> or when INx toggles.
			H				Output latch off. Fault recovers when INx toggles.
Thermal swing	H	—	—	T <sub>SW</sub> triggered	V <sub>CS_FAULT</sub>	L	Auto

(1) An external pullup is required for open-load detection.

(2) L = logical zero (false), H = logical one (true), — = don't care

### 8.3.5.4 FAULT Reporting

A global  $\overline{\text{FAULT}}$  pin is used to monitor the global fault condition among all the channels. When a fault condition occurs on any channel, the  $\overline{\text{FAULT}}$  pin is pulled down to GND. A 3.3-V or 5-V external pullup is required to match the supply level of the house-keeping processor.

After the  $\overline{\text{FAULT}}$  report, the processor can check and identify the channel in fault status by using the multiplexed current sensing pin. The CS pin also works as a fault report with an internal pullup voltage, V<sub>CS\_FAULT</sub>.

## 8.3.6 Full Diagnostics

### 8.3.6.1 Short-to-GND and Overload Detection

When a channel is on, a short to GND or overload condition causes overcurrent. If the overcurrent triggers either the internal or external current-limit threshold, the fault condition is reported out. The microcontroller can handle the overcurrent by turning off the switch. The device heats up if no actions are taken. If a thermal shutdown

occurs, the current limit is  $I_{CL\_TSD}$  (70% of the externally set current limit) or  $I_{CL\_INTERNAL\_TSD}$  (6.5 A when using the internal current limit) to keep the power stressing on the power FET to a minimum. The device automatically recovers when the fault condition is removed.

### 8.3.6.2 Open-Load Detection

#### 8.3.6.2.1 Channel On

When a channel is on ( $ENx = \text{High}$ ), benefiting from the high-accuracy current sense in a small current range, if an open-load event occurs, it can be detected as an ultra-low  $V_{CS}$  and handled by the microcontroller. Note that the detection is not reported on the  $\overline{\text{FAULT}}$  pin. The microcontroller must multiplex the SEL and SEH pins to detect the channel-on open-load fault proactively.

#### 8.3.6.2.2 Channel Off

When a channel is off, if a load is connected, the output is pulled down to GND. But if an open load occurs, the output voltage is close to the supply voltage ( $V_{IN} - V_{OUTx} < V_{OL\_OFF}$ ), and the fault is reported out.  $V_{OL\_OFF}$  is between 1.6 and 2.6 V.

There is always a leakage current  $I_F$  (maximum of 0.5  $\mu\text{A}$  at 25°C or 8  $\mu\text{A}$  at 125°C), present on the output due to internal logic control path or external humidity, corrosion, and so forth. Thus, TI recommends an external pullup resistor to offset the leakage current when an open load is detected. The recommended pullup resistance is 20 k $\Omega$ .

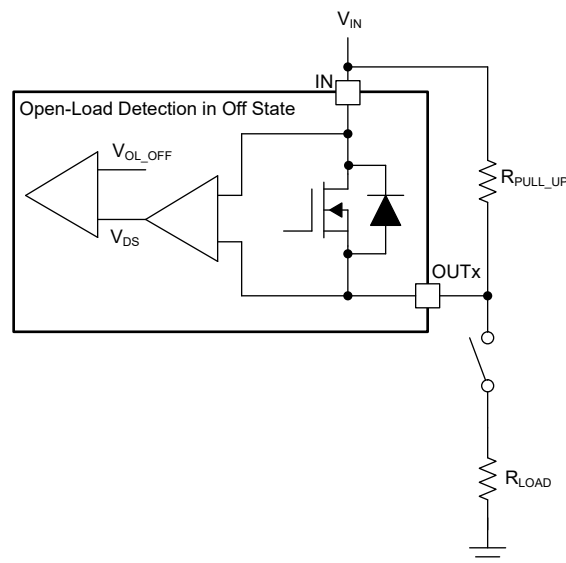


Figure 8-9. Open-Load Detection in Off-State

### 8.3.6.3 Short-to-Input Detection

Short-to-Input has the same detection mechanism and behavior as open-load detection, in both the on-state and off-state. See [Table 8-3](#) for more details.

In the on-state, reverse current flows through the FET instead of the body diode, leading to less power dissipation. Thus, the worst case occurs in the off-state.

- If  $V_{OUTx} - V_{IN} < V_F$  (body diode forward voltage), no reverse current occurs.
- If  $V_{OUTx} - V_{IN} > V_F$ , reverse current occurs. The current must be limited to less than  $I_{R1}$ . Setting an  $ENx$  pin high can minimize the power stress on its channel. Also, for external reverse protection, see [Reverse-Current Protection](#) for more details.

### 8.3.6.4 Reverse Polarity Detection

Reverse polarity detection has the same detection mechanism and behavior as open-load detection both in the on-state and off-state. See [Table 8-3](#) for more details.

In the on-state, the reverse current flows through the FET instead of the body diode, leading to less power dissipation. Thus, the worst case occurs in the off-state. The reverse current must be limited to less than  $I_{R2}$ . Set the related ENx pin high to keep the power dissipation to a minimum. For external reverse-blocking circuitry, see [Reverse-Current Protection](#) for more details.

### 8.3.6.5 Thermal Fault Detection

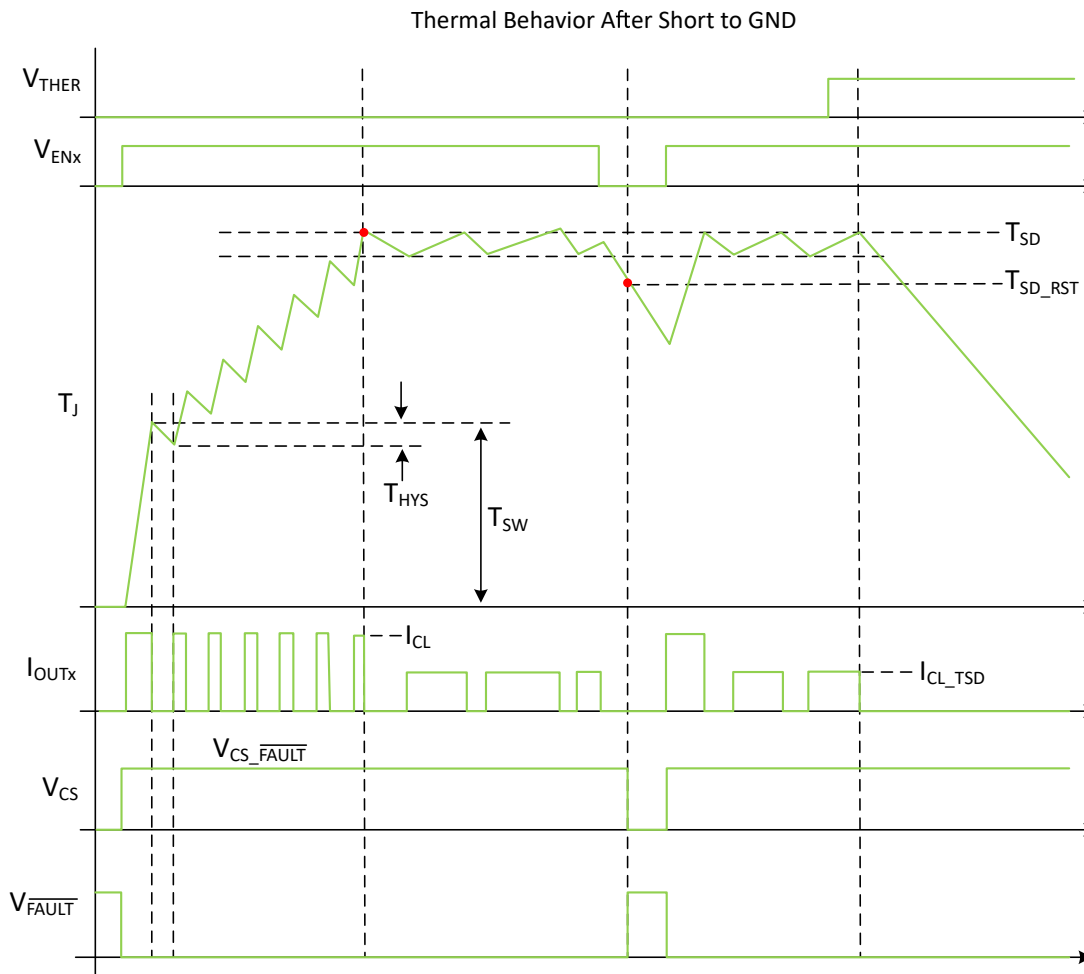
To protect the device in severe power stressing cases, the device implements two types of thermal fault detection, absolute temperature protection (thermal shutdown) and dynamic temperature protection (thermal swing). Respective temperature sensors are integrated close to each power FET, so the thermal fault is reported by each channel. This arrangement can help the device keep the cross-channel effect to a minimum when some channels are in a thermal fault condition.

#### 8.3.6.5.1 Thermal Shutdown

Thermal shutdown is active when the absolute temperature  $T_J > T_{SD}$ . When thermal shutdown occurs, the respective output turns off. The THER pin is used to configure the behavior after the thermal shutdown occurs.

- When the **THER** pin is low, thermal shutdown operates in the auto-retry mode. The output automatically recovers when  $T_J < T_{SD} - T_{HYS}$ , but the current is limited to  $I_{CL\_TSD}$  or  $I_{CL\_INTERNAL\_TSD}$  (depending if the internal or external current limit is used) to avoid repetitive thermal shutdown. The thermal shutdown fault signal is cleared when  $T_J < T_{SD\_RST}$  or after toggling the related ENx pin.
- When the **THER** pin is high, thermal shutdown operates in the latch mode. The output latches off when thermal shutdown occurs. When the THER pin goes from high to low, thermal shutdown changes to auto-retry mode. The thermal shutdown fault signal is cleared after toggling the related ENx pin.

Thermal swing activates when the power FET temperature is increasing sharply, that is, when  $\Delta T = T_{FET} - T_{LOGIC} > T_{SW}$ , then the output turns off. The output automatically recovers and the fault signal clears when  $\Delta T = T_{FET} - T_{LOGIC} < T_{SW} - T_{HYS}$ . Thermal swing function improves the device reliability when subjected to repetitive fast thermal variation. As shown in [Figure 8-10](#), multiple thermal swings are triggered before thermal shutdown occurs.



**Figure 8-10. Thermal Behavior Diagram**

### 8.3.7 Full Protections

#### 8.3.7.1 UVLO Protection

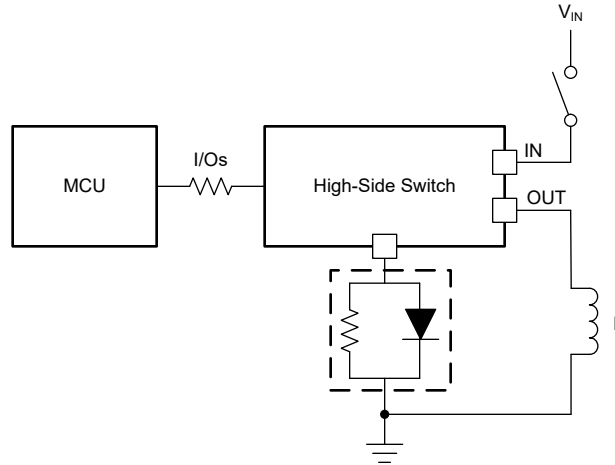
The device monitors the supply voltage  $V_{IN}$ , to prevent unpredicted behaviors when  $V_{IN}$  is too low. When  $V_{IN}$  falls down to  $IN_{UVLOF}$ , the device shuts down. When  $V_{IN}$  rises up to  $IN_{UVLOR}$ , the device turns on.

#### 8.3.7.2 Loss-of-GND Protection

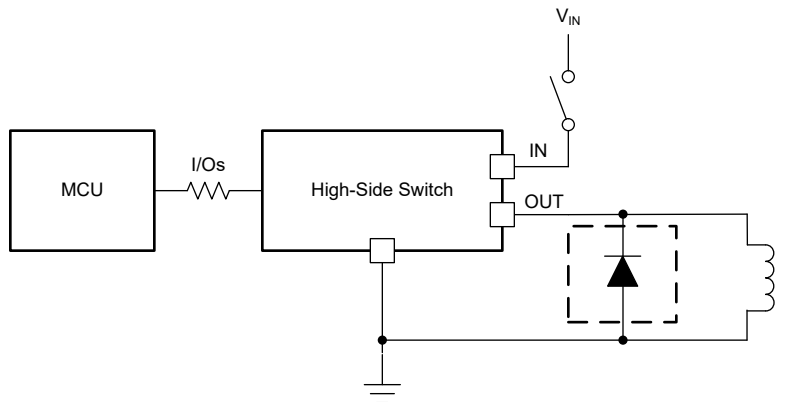
When loss of GND occurs, output is shut down regardless of whether the ENx pin is high or low. The device can protect against two ground-loss conditions, loss of device GND and loss of module GND.

#### 8.3.7.3 Protection for Loss of Power Supply

When loss of supply occurs, the output is shut down regardless of whether the ENx pin is high or low. For a resistive or a capacitive load, loss of supply has no risk. But for a charged inductive load, the current is driven from all the I/O pins to maintain the inductance current. To protect the system in this condition, TI recommends two types of external protections: the GND network or the external free-wheeling diode.



**Figure 8-11. Protection for Loss of Power Supply, Method 1**



**Figure 8-12. Protection for Loss of Power Supply, Method 2**

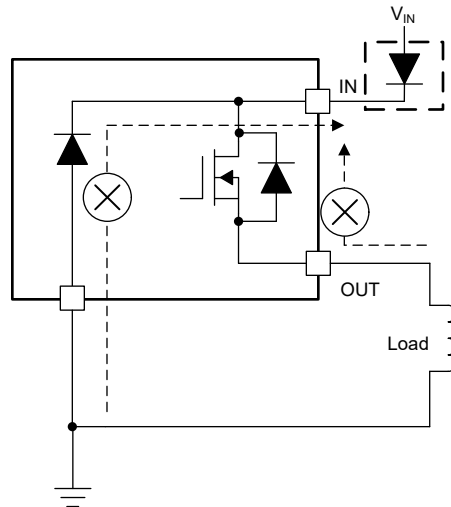
#### 8.3.7.4 Reverse-Current Protection

Reverse current occurs in two conditions: short to power and reverse polarity.

- When a short to the input occurs, there is only reverse current through the body diode.  $I_{R1}$  specifies the limit of the reverse current.
- In a reverse-polarity condition, there are reverse currents through the body diode and the device GND pin.  $I_{R2}$  specifies the limit of the reverse current. The GND pin maximum current is specified in the [Absolute Maximum Ratings](#).

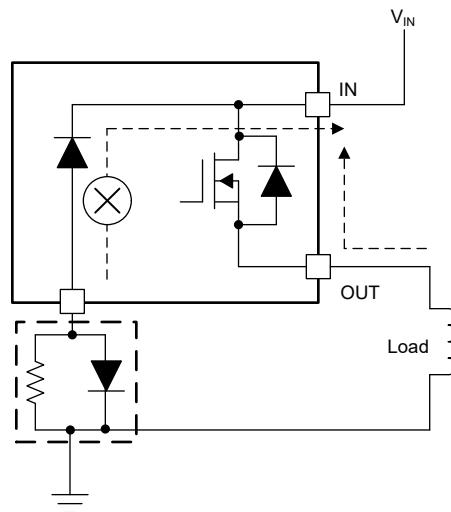
To protect the device, TI recommends two types of external circuitry.

- Adding a blocking diode. Both the IC and load are protected when in reverse polarity.



**Figure 8-13. Reverse-Current External Protection, Method 1**

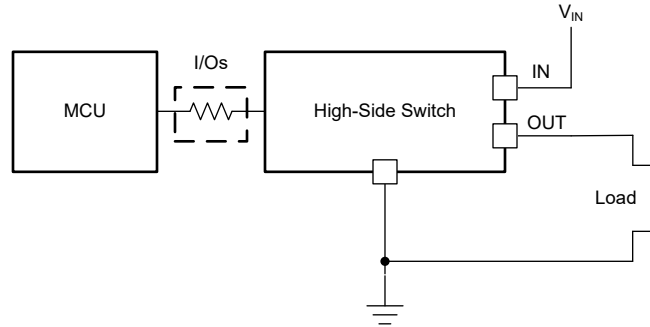
- Adding a GND network. The reverse current through the device GND is blocked. The reverse current through the FET is limited by the load itself. TI recommends a resistor in parallel with the diode as a GND network. The recommended selection are 1-k $\Omega$  resistor in parallel with a >100-mA diode. If multiple high-side switches are used, the resistor and diode can be shared among devices. The reverse current protection diode in the GND network forward voltage should be less than 0.6 V in any circumstances. In addition a minimum resistance of 4.7 k $\Omega$  is recommended on the I/O pins.



**Figure 8-14. Reverse-Current External Protection, Method 2**

### 8.3.7.5 MCU I/O Protection

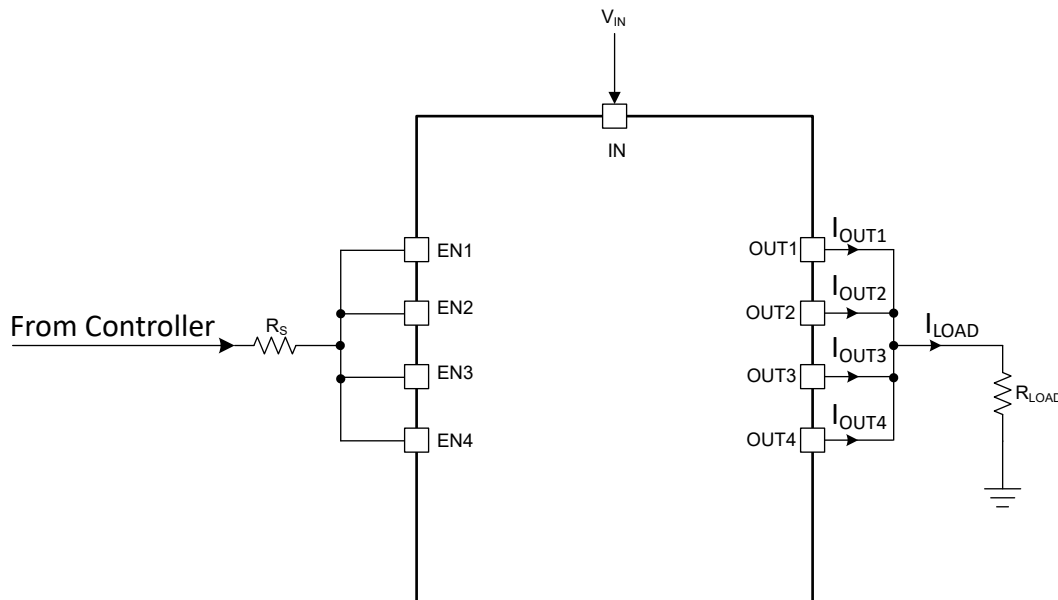
In some severe systems conditions the loss of power with inductive loads, results on a negative pulse on the GND pin. This pulse can cause damage on the connected microcontroller. TI recommends serial resistors to protect the microcontroller, for example, 4.7 k $\Omega$  when using a 3.3-V microcontroller and 10 k $\Omega$  for a 5-V microcontroller.



**Figure 8-15. MCU I/O External Protection**

### 8.3.8 Parallel Operation

The TPS7H2140-SEP can be configured in parallel operation either to increase the current capability, up to 5.4 A, or to reduce the  $R_{ON}$  (on-state resistance). Any channels combination can be parallel by connecting the desired channels outputs ( $OUT_x$ ) and enable ( $EN_x$ ) signals together. Figure 8-16 shows the input/output connections when paralleling all 4 channels of the TPS7H2140-SEP



**Figure 8-16. Input and Output Connections when paralleling all channels in the TPS7H2140-SEP**

For proper device operation follow the following recommendations:

1. Connect the  $EN_x$  inputs signals of the channels to be parallel together and as close to the device (I.C.) as possible.
2. Connect the  $OUT_x$  output signals of the channels to be parallel together and as close to the device (I.C.) as possible.
3. Take in consideration the deviations (or errors) in the  $R_{ON}$ , current limit and voltage clamp for the system design.

Due to imbalance of currents in each channel (due to  $\Delta R_{ON}$ ) the total load current is not equally distributed. The channel current bounds are:

$$\bullet \quad I_n(\max) = \frac{I_{LOAD}}{N} \times \left( \frac{1 + \Delta R_{ON}}{1 - \Delta R_{ON}} \right) \quad (13)$$

$$I_n(\min) = \frac{I_{LOAD}}{N} \times \left( \frac{1 - \Delta R_{ON}}{1 + \Delta R_{ON}} \right) \quad (14)$$

where N is equal to the # of parallel channels and  $\Delta R_{ON}$  is the difference between the on-state resistance for any given channel.

At 25 °C the  $\Delta R_{ON}$  maximum value is specified at 6 % (or 0.06), using this value and assuming the  $I_{LOAD}$  is 5 A the current by each channel can be calculated (using [Equation 13](#) and [Equation 14](#)) as:

$$1.11 \leq I_n \leq 1.41 \quad (15)$$

When paralleling channels is important to know that the current limit is programmed per channel based (or the same for all channels). The sensed current ratio on the current limit circuit have variations (as specified by  $dK_{CL}/K_{CL}$ ). To deliver the expected load before reaching the current limit the designer must account for variation on the sensed current gain and variations on the channels currents due to on-resistance mismatch as described before. To select the current limit resistor when accounting for all system errors ( $\Delta R_{ON}$  and  $dK_{CL}/K_{CL}$ ) use:

$$R_{CL}(\max) = \frac{V_{CL\_TH} \times K_{CL} \left( 1 - \left| \frac{dK_{CL}}{K_{CL}} \right| \right)}{I_n(\max)} \quad (16)$$

As the sensed current is measured in a per channel based and reported on the CS pin. To measure the total load current of parallel channels, the individual current must be measured and added together. The individual currents are measured by using the SEH and SEL (mux inputs) in conjunction with the CS voltage.

The diagnostics as specified by [Fault Table](#) are globally reported, as the fault conditions affects all channels simultaneously. When using the internal clamp ( $V_{DS\_CLAMP}$ ) to dissipate the inductive kick-back energy the energy must be limited to the maximum of a single channel.

---

#### Note

The energy does not scale with the number of parallel channels and must be limited to the absolute maximum value of 40mJ.

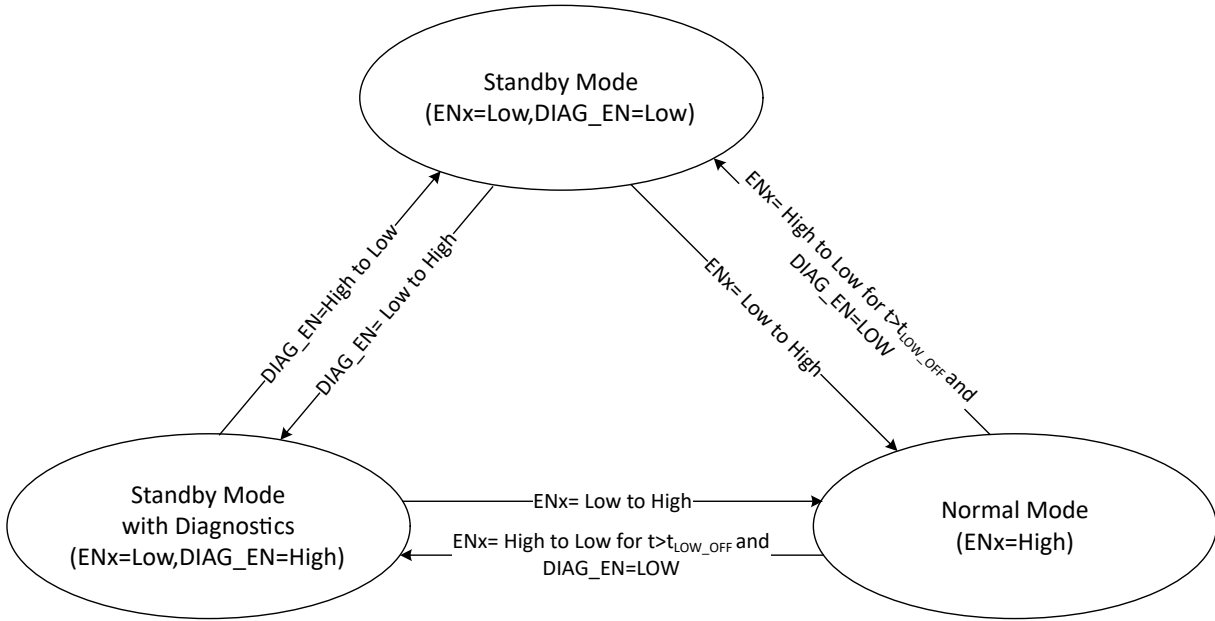
---

## 8.4 Device Functional Modes

### 8.4.1 Working Modes

The device has three working modes: normal mode, standby mode, and standby mode with diagnostics.

Note that ENx must be low for  $t > t_{LOW\_OFF}$  to enter the standby mode, where  $t_{LOW\_OFF}$  is the standby mode deglitch time used to avoid false triggering. [Figure 8-17](#) shows a working-mode diagram.



**Figure 8-17. Working Modes**

## 9 Application and Implementation

### Note

Information in the following applications sections is not part of the TI component specification, and TI does not warrant its accuracy or completeness. TI's customers are responsible for determining suitability of components for their purposes, as well as validating and testing their design implementation to confirm system functionality.

### 9.1 Application Information

The TPS7H2140-SEP device is capable of driving a wide variety of resistive, inductive, and capacitive loads, including: relays, solenoids, heaters, and sub-modules. Full diagnostics and high-accuracy current-sense features enable intelligent control of the load. An external adjustable current limit improves the reliability of the whole system by clamping the inrush or overload current.

### 9.2 Typical Application

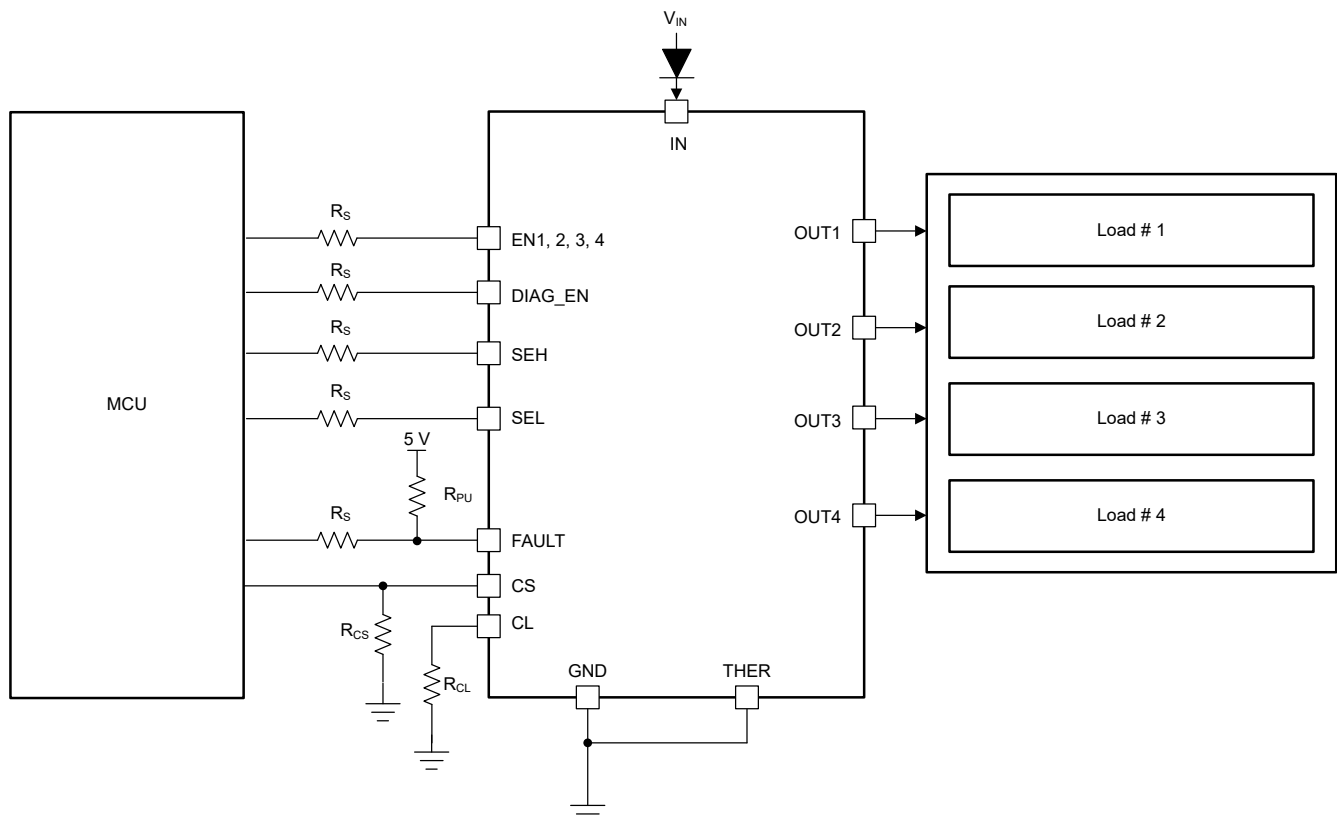


Figure 9-1. Typical Application Diagram

#### 9.2.1 Design Requirements

- $V_{IN} = 12\text{ V}$
- Maximum load current up to 1 A (nominal) and for each channel
- Up to 1.1 A during transients before the current is limited.
- Current sense for fault monitoring
- Expected current-limit value of 1.1 A
- Automatic recovery mode when thermal shutdown occurs
- Full diagnostics with 5-V MCU/FPGA
- Reverse-voltage protection with a blocking diode in the power-supply line

### 9.2.2 Detailed Design Procedure

When selecting the current limit resistor we most account for the accuracy of the limit. The accuracy on the range of the desired current limit is  $\pm 20\%$ .

As the current limit can be shifted up to  $-20\%$ , is desired to boost the load current by this factor. In which case the load current for the calculation of the current limit is: 1.375 A.

To keep the 1.1 A nominal current in the 0 to 4 V current-sense range, calculate the  $R_{CS}$  resistor using Equation 17. To achieve better current-sense accuracy, a 1% tolerance or better resistor is preferred.

$$R_{CS} = \frac{V_{CS}}{I_{CS}} = \frac{V_{CS} \times K_{CS}}{I_{OUTx}} = \frac{4 \times 300}{1.1} = 1.09 \text{ k}\Omega \quad (17)$$

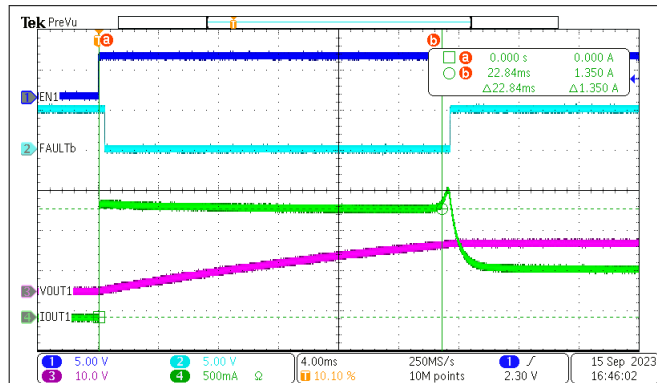
To set the adjustable current limit value at 2.5 A, calculate  $R_{CL}$  using Equation 18.

$$R_{CL} = \frac{V_{CL\_TH} \times K_{CL}}{I_{OUTx}} = \frac{0.8 \times 2500}{1.375} = 1.45 \text{ k}\Omega \quad (18)$$

TI recommends  $R_S = 10 \text{ k}\Omega$  for 5-V MCU, and  $R_{PU} = 10 \text{ k}\Omega$  as the pullup resistor.

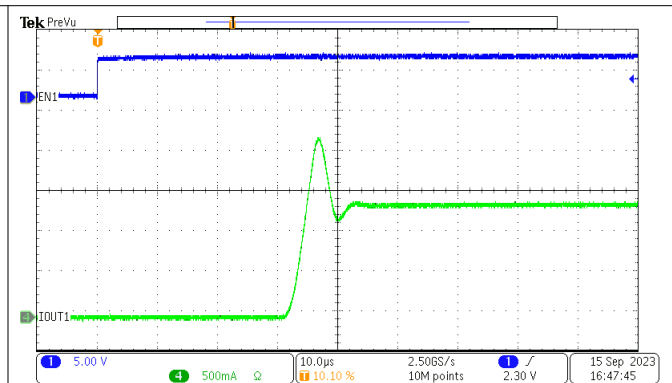
### 9.2.3 Application Curves

Figure 9-2 shows a test example of soft-start when driving a big capacitive load. Figure 9-3 shows an expanded waveform of the output current.



$V_{IN} = 12 \text{ V}$        $ENx = \uparrow$        $I_{CL} = 1.35 \text{ A}$   
 $R_{OUT1} = 20 \Omega$     $C_{OUT1} = 2.201 \text{ mF}$     $CH1 = V_{EN1} = \text{Blue}$   
 $CH2 = V_{FAULT} = \text{Cyan}$     $CH3 = V_{OUT1} = \text{Magenta}$     $CH4 = I_{OUT1} = \text{Green}$

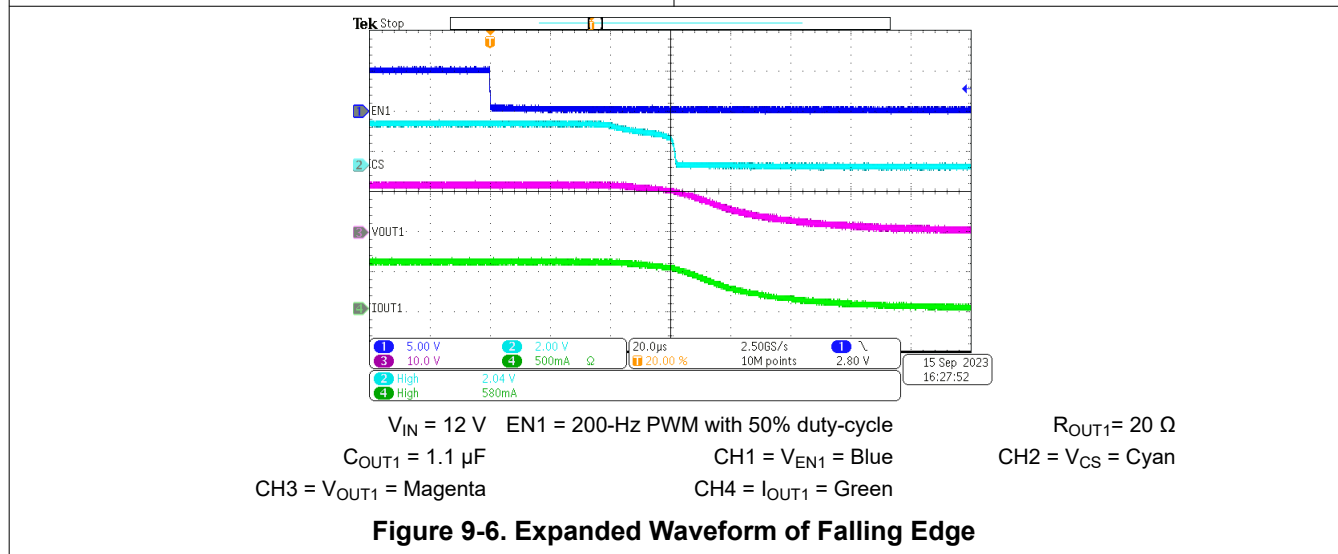
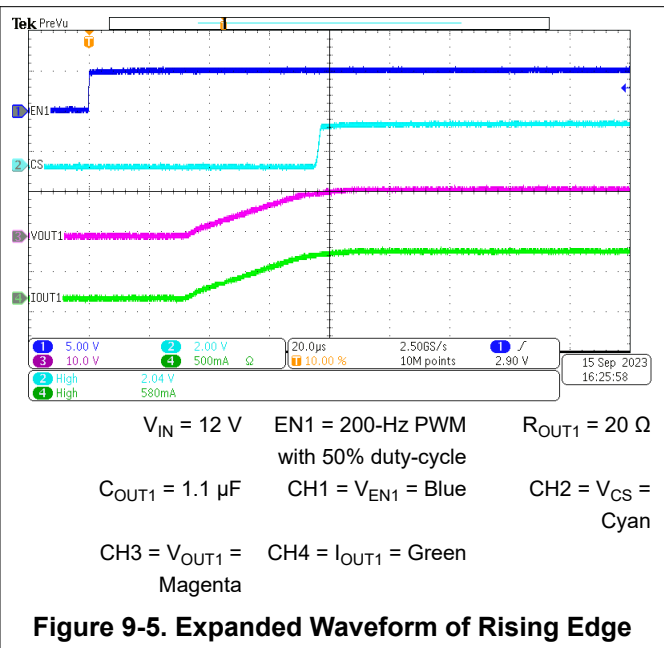
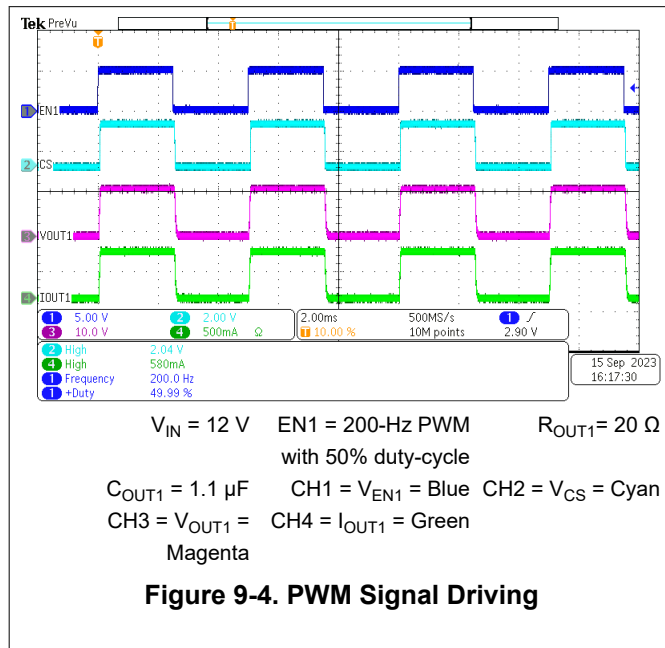
**Figure 9-2. Driving a Capacitive Load With Adjustable Current Limit**



$V_{IN} = 12 \text{ V}$        $ENx = \uparrow$        $I_{CL} = 1.35 \text{ A}$   
 $R_{OUT1} = 20 \Omega$     $C_{OUT1} = 2.201 \text{ mF}$   
 $CH1 = V_{EN1} = \text{Blue}$     $CH4 = I_{OUT1} = \text{Green}$

**Figure 9-3. Driving a Capacitive Load, Expanded Waveform**

Figure 9-4 shows a test example of PWM-mode driving. Figure 9-5 shows the expanded waveform of the rising edge. Figure 9-6 shows the expanded waveform of the falling edge.



### 9.3 Power Supply Recommendations

The TPS7H2140-SEP is designed to operate from an input range between 4.5 V to 32 V. This supply voltage must be well regulated and proper local bypass capacitors should be used for proper electrical performance from  $V_{IN}$  to GND. Due to stringent requirements for space applications, typically numerous input bypass capacitors are used and the total capacitance is much larger than for commercial applications. The TPS7H2140-SEP evaluation module uses one 33- $\mu\text{F}$  tantalum capacitor in parallel with one 10- $\mu\text{F}$ , one 1- $\mu\text{F}$ , and one 0.1- $\mu\text{F}$  ceramic capacitor.

## 9.4 Layout

### 9.4.1 Layout Guidelines

To prevent thermal shutdown,  $T_J$  must be less than  $150^{\circ}\text{C}$ . The HTSSOP package has good thermal impedance. However, the PCB layout is very important. Good PCB design can optimize heat transfer, which is absolutely essential for the long-term reliability of the device.

- Maximize the copper coverage on the PCB to increase the thermal conductivity of the board. Maximum copper is extremely important when there are not any heat sinks attached to the PCB on the other side of the package.
- Add as many thermal vias as possible directly under the package ground pad to optimize the thermal conductivity of the board.
- All thermal vias should either be plated shut or plugged and capped on both sides of the board to prevent solder voids. To ensure reliability and performance, it is recommended a solder coverage greater than 85%.

### 9.4.2 Layout Examples

#### 9.4.2.1 Without a GND Network

Without a GND network, tie the thermal pad directly to the board GND copper for better thermal performance.

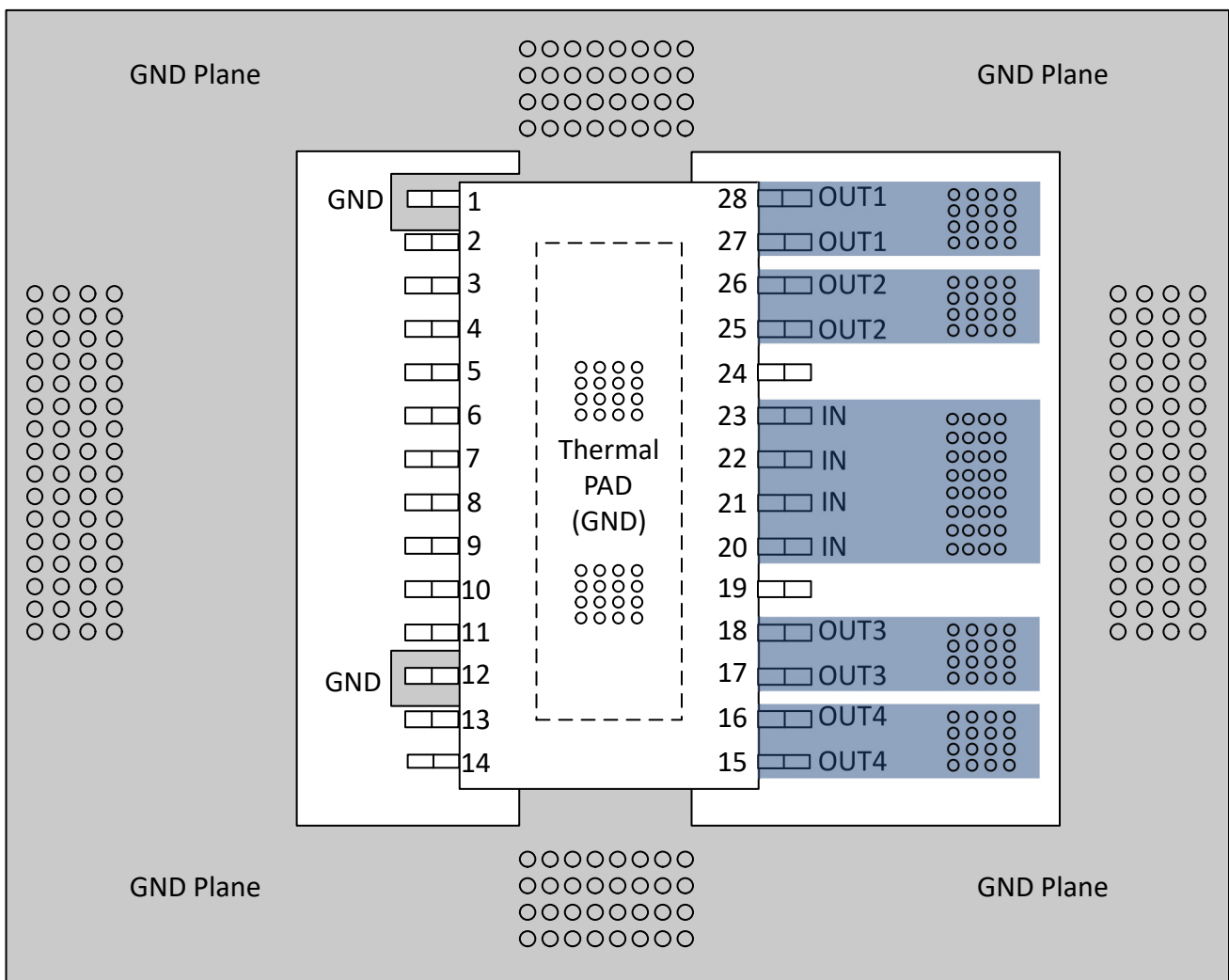


Figure 9-7. Layout Example Without a GND Network

### 9.4.2.2 With a GND Network

With a GND network, tie the thermal pad as one trace to the board GND copper.

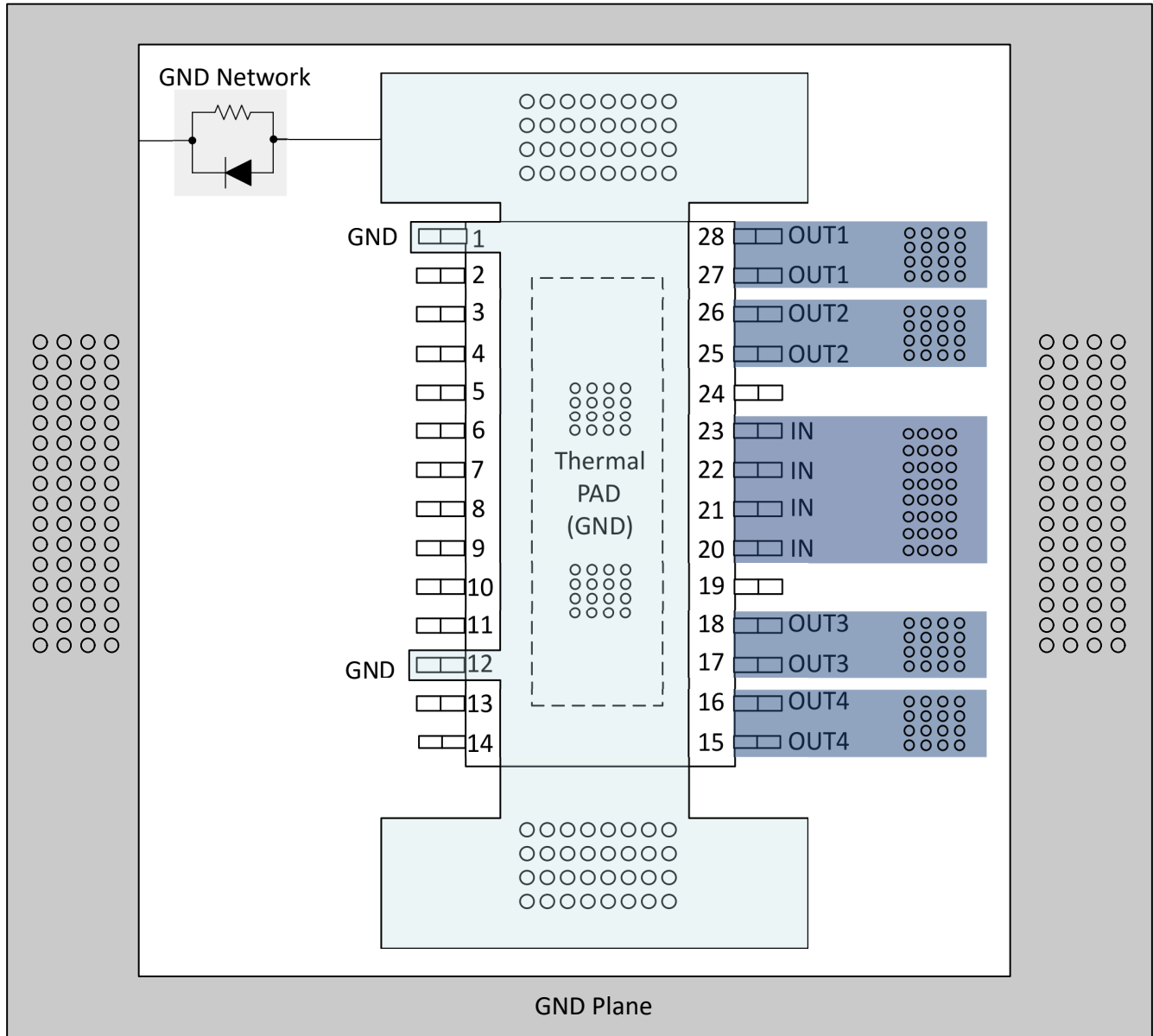


Figure 9-8. Layout Example With a GND Network

## 10 Device and Documentation Support

### 10.1 Documentation Support

#### 10.1.1 Related Documentation

For related documentation see the following:

- Texas Instruments, [TPS7H2140-SEP Total Ionizing Dose \(TID\)](#)
- Texas Instruments, [Single-Event-Effects Test Report of the TPS7H2140-SEP Quad-channel eFuse](#)
- Texas Instruments, [TPS7H2140-SEP NDD Report](#)
- Texas Instruments, [TPS7H2140EVM Evaluation Module \(EVM\)](#)
- Texas Instruments, [Unencrypted PSpice Transient Model](#)
- Texas Instruments, [Load Switch Thermal Considerations](#)
- Texas Instruments, [Basics of eFuses](#)
- Texas Instruments, [Basics of Load Switches](#)
- Vendor Item Drawing, [V6223610](#)

#### 10.2 Receiving Notification of Documentation Updates

To receive notification of documentation updates, navigate to the device product folder on [ti.com](#). Click on *Subscribe to updates* to register and receive a weekly digest of any product information that has changed. For change details, review the revision history included in any revised document.

#### 10.3 Support Resources

[TI E2E™ support forums](#) are an engineer's go-to source for fast, verified answers and design help — straight from the experts. Search existing answers or ask your own question to get the quick design help you need.

Linked content is provided "AS IS" by the respective contributors. They do not constitute TI specifications and do not necessarily reflect TI's views; see TI's [Terms of Use](#).

#### 10.4 Trademarks

TI E2E™ is a trademark of Texas Instruments.  
All trademarks are the property of their respective owners.

#### 10.5 Electrostatic Discharge Caution



This integrated circuit can be damaged by ESD. Texas Instruments recommends that all integrated circuits be handled with appropriate precautions. Failure to observe proper handling and installation procedures can cause damage.

ESD damage can range from subtle performance degradation to complete device failure. Precision integrated circuits may be more susceptible to damage because very small parametric changes could cause the device not to meet its published specifications.

#### 10.6 Glossary

[TI Glossary](#) This glossary lists and explains terms, acronyms, and definitions.

## 11 Mechanical, Packaging, and Orderable Information

The following pages include mechanical, packaging, and orderable information. This information is the most-current data available for the designated device. This data is subject to change without notice and without revision of this document. For browser-based versions of this data sheet, see the left-hand navigation pane.

## PACKAGING INFORMATION

Orderable part number	Status (1)	Material type (2)	Package   Pins	Package qty   Carrier	RoHS (3)	Lead finish/ Ball material (4)	MSL rating/ Peak reflow (5)	Op temp (°C)	Part marking (6)
<a href="#">TPS7H2140MPWPTSEP</a>	Active	Production	HTSSOP (PWP)   28	250   SMALL T&R	Yes	NIPDAU	Level-3-260C-168 HR	-55 to 125	7H2140PWP
TPS7H2140MPWPTSEP.A	Active	Production	HTSSOP (PWP)   28	250   SMALL T&R	Yes	NIPDAU	Level-3-260C-168 HR	-55 to 125	7H2140PWP
V62/23610-01XE	Active	Production	HTSSOP (PWP)   28	250   SMALL T&R	Yes	NIPDAU	Level-3-260C-168 HR	-55 to 125	7H2140PWP

(1) **Status:** For more details on status, see our [product life cycle](#).

(2) **Material type:** When designated, preproduction parts are prototypes/experimental devices, and are not yet approved or released for full production. Testing and final process, including without limitation quality assurance, reliability performance testing, and/or process qualification, may not yet be complete, and this item is subject to further changes or possible discontinuation. If available for ordering, purchases will be subject to an additional waiver at checkout, and are intended for early internal evaluation purposes only. These items are sold without warranties of any kind.

(3) **RoHS values:** Yes, No, RoHS Exempt. See the [TI RoHS Statement](#) for additional information and value definition.

(4) **Lead finish/Ball material:** Parts may have multiple material finish options. Finish options are separated by a vertical ruled line. Lead finish/Ball material values may wrap to two lines if the finish value exceeds the maximum column width.

(5) **MSL rating/Peak reflow:** The moisture sensitivity level ratings and peak solder (reflow) temperatures. In the event that a part has multiple moisture sensitivity ratings, only the lowest level per JEDEC standards is shown. Refer to the shipping label for the actual reflow temperature that will be used to mount the part to the printed circuit board.

(6) **Part marking:** There may be an additional marking, which relates to the logo, the lot trace code information, or the environmental category of the part.

Multiple part markings will be inside parentheses. Only one part marking contained in parentheses and separated by a "-" will appear on a part. If a line is indented then it is a continuation of the previous line and the two combined represent the entire part marking for that device.

**Important Information and Disclaimer:** The information provided on this page represents TI's knowledge and belief as of the date that it is provided. TI bases its knowledge and belief on information provided by third parties, and makes no representation or warranty as to the accuracy of such information. Efforts are underway to better integrate information from third parties. TI has taken and continues to take reasonable steps to provide representative and accurate information but may not have conducted destructive testing or chemical analysis on incoming materials and chemicals. TI and TI suppliers consider certain information to be proprietary, and thus CAS numbers and other limited information may not be available for release.

In no event shall TI's liability arising out of such information exceed the total purchase price of the TI part(s) at issue in this document sold by TI to Customer on an annual basis.

**TAPE AND REEL INFORMATION**

**QUADRANT ASSIGNMENTS FOR PIN 1 ORIENTATION IN TAPE**


\*All dimensions are nominal

Device	Package Type	Package Drawing	Pins	SPQ	Reel Diameter (mm)	Reel Width W1 (mm)	A0 (mm)	B0 (mm)	K0 (mm)	P1 (mm)	W (mm)	Pin1 Quadrant
TPS7H2140MPWPTSEP	HTSSOP	PWP	28	250	178.0	16.4	6.95	10.0	1.7	8.0	16.0	Q1

**TAPE AND REEL BOX DIMENSIONS**


\*All dimensions are nominal

Device	Package Type	Package Drawing	Pins	SPQ	Length (mm)	Width (mm)	Height (mm)
TPS7H2140MPWPTSEP	HTSSOP	PWP	28	250	210.0	185.0	35.0

## GENERIC PACKAGE VIEW

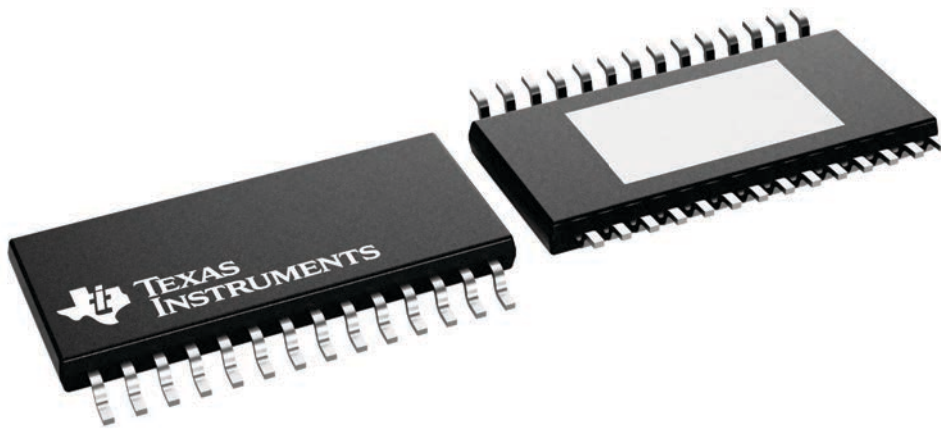
**PWP 28**

**PowerPAD™ TSSOP - 1.2 mm max height**

4.4 x 9.7, 0.65 mm pitch

SMALL OUTLINE PACKAGE

This image is a representation of the package family, actual package may vary.  
Refer to the product data sheet for package details.



4224765/B

## IMPORTANT NOTICE AND DISCLAIMER

TI PROVIDES TECHNICAL AND RELIABILITY DATA (INCLUDING DATASHEETS), DESIGN RESOURCES (INCLUDING REFERENCE DESIGNS), APPLICATION OR OTHER DESIGN ADVICE, WEB TOOLS, SAFETY INFORMATION, AND OTHER RESOURCES "AS IS" AND WITH ALL FAULTS, AND DISCLAIMS ALL WARRANTIES, EXPRESS AND IMPLIED, INCLUDING WITHOUT LIMITATION ANY IMPLIED WARRANTIES OF MERCHANTABILITY, FITNESS FOR A PARTICULAR PURPOSE OR NON-INFRINGEMENT OF THIRD PARTY INTELLECTUAL PROPERTY RIGHTS.

These resources are intended for skilled developers designing with TI products. You are solely responsible for (1) selecting the appropriate TI products for your application, (2) designing, validating and testing your application, and (3) ensuring your application meets applicable standards, and any other safety, security, regulatory or other requirements.

These resources are subject to change without notice. TI grants you permission to use these resources only for development of an application that uses the TI products described in the resource. Other reproduction and display of these resources is prohibited. No license is granted to any other TI intellectual property right or to any third party intellectual property right. TI disclaims responsibility for, and you fully indemnify TI and its representatives against any claims, damages, costs, losses, and liabilities arising out of your use of these resources.

TI's products are provided subject to [TI's Terms of Sale](#), [TI's General Quality Guidelines](#), or other applicable terms available either on [ti.com](http://ti.com) or provided in conjunction with such TI products. TI's provision of these resources does not expand or otherwise alter TI's applicable warranties or warranty disclaimers for TI products. Unless TI explicitly designates a product as custom or customer-specified, TI products are standard, catalog, general purpose devices.

TI objects to and rejects any additional or different terms you may propose.

Copyright © 2026, Texas Instruments Incorporated

Last updated 10/2025