

Benefits of Gate Driver Single Input, Dead Time, and Integrated Diode Features



Walter Zollinger

ABSTRACT

This application note focuses on half-bridge gate drivers from Texas Instruments with single input, enable, adjustable dead time, and integrated bootstrap diode features and relevant applications such as appliances and motor drives. Gate drivers with single input or adjustable dead time features can help simplify design complexity by requiring less microcontroller resources. These devices can also help make gate driver designs more cost effective by lowering external component count. [Table 4-1](#) lists a summary comparison between features of the devices discussed in this application note.

Table of Contents

1 Introduction	2
2 Key Features	2
2.1 Single Input Capability.....	2
2.2 Enable and Shutdown Input.....	3
2.3 Dead Time and Interlock.....	4
2.4 Integrated Bootstrap Diode.....	5
3 Application Considerations	6
4 Summary	7
4.1 Device Summary.....	7
5 References	8

Trademarks

All trademarks are the property of their respective owners.

1 Introduction

There are many key features of gate driver devices that can offer significant benefits to the performance and design of an end application. Four of these features are single input capability, an enable or shutdown input, dead time and interlock, and an integrated bootstrap diode.

2 Key Features

2.1 Single Input Capability

In a half-bridge gate driver with independent inputs, a low-side input controls only the low-side transistor output and a high-side input controls only the high-side transistor output. A single input gate driver controls the two outputs with a single pin driven by a pulse width modulated (PWM) signal. When the PWM input signal is low, the low-side output is driven high and the high-side output is driven low. When the PWM input signal is high, the high-side output is driven high and the low-side output is driven low. This is shown in [Figure 2-1](#).

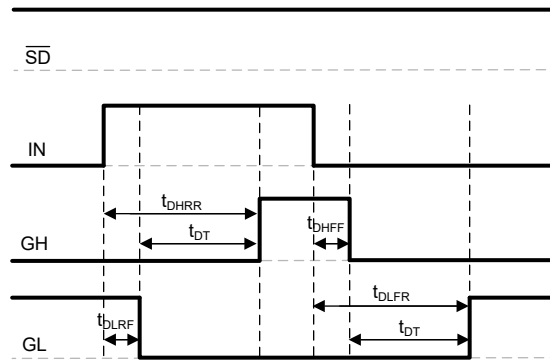

Figure 2-1. LM2104 Single Input Half-Bridge Gate Driver Timing Diagram

In applications using a microcontroller with a limited number of available PWM or general-purpose input/output (GPIO) pins, a gate driver with a single PWM input capability reduces the required number of controller outputs by half. This makes single input drivers especially helpful in multiphase applications. For example, a three-phase brushless DC motor (BLDC) system driven by three single input half-bridge drivers only uses three microcontroller PWM output pins instead of the six output pins that are required to control three gate drivers with independent inputs.

Using a microcontroller with fewer PWM outputs can save cost and board space. Single input gate drivers can also save on cost and board space by using only a single input filter if required to filter out input noise when compared to independent input devices that can require a filter for both the high-side and low-side inputs.

[LM2104 Single Input Pin and Separate Shutdown Pin](#) shows LM2104 with a single PWM input pin. If a gate driver has an independent high-side input and inverting low-side input, the two inputs can be bridged together and used as a single PWM input as shown in [Figure 2-2](#) using LM2103.

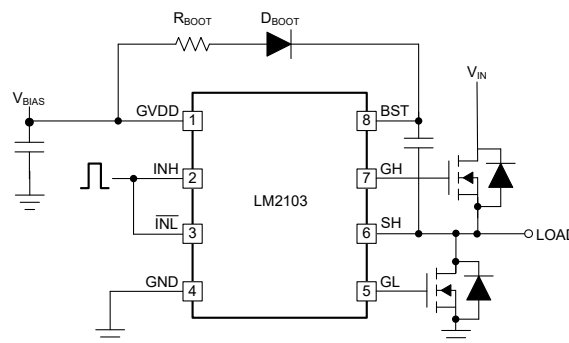

Figure 2-2. Using the Inverting and Non-inverting Inputs as a Single Input

2.2 Enable and Shutdown Input

Gate drivers with an enable or shutdown pin offer the flexibility to turn off both outputs of a half-bridge driver regardless of the input signal with a single pin. This feature can be valuable in systems where rapid response to a fault is a priority. Using the enable or shutdown pin, the gate driver outputs can be quickly switched low and the PWM input disabled in response to a detected fault and help bring the system to a steady state. This feature is also important to half-bridge drivers with a single PWM input as there is no way to create an off state (HO and LO both off) without an enable or shutdown pin or powering down the device. The shutdown or enable pin can have inverting or normal logic depending on the device.

In a multiphase power converter, this feature also allows for unused phases to be switched on and off in response to load conditions. Efficiency is improved by shedding additional phases when the switching losses are higher at light loads and adding phases to reduce the conduction losses in each phase with heavy loads. The enable or shutdown pin can also be used to decrease standby current consumption by shutting down the gate driver when switching is not needed.

Figure 2-3 shows LM2104 as an example of a gate driver with a single PWM input and an inverting shutdown pin.

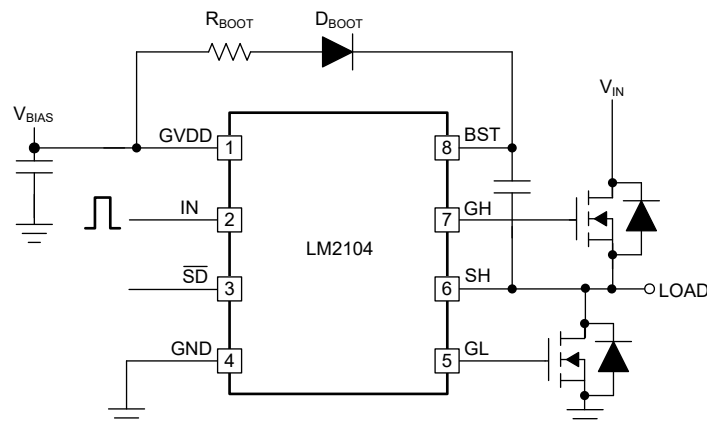

Figure 2-3. LM2104 Single Input Pin and Separate Shutdown Pin

2.3 Dead Time and Interlock

In applications using a gate driver with independent high-side and low-side input controls, dead time is typically added to the driver input signals to prevent cross-conduction, or shoot-through, between the output transistors. This cross-conduction protection is important as a shoot-through event can cause excess current draw or even damage the output transistors and PCB.

Input interlock is a feature of gate drivers such as [LM5108](#) that turns off the high-side and low-side outputs if the two input signals are simultaneously high. This function filters out any shoot-through conditions on the input such as noise. As input interlock only controls input overlap and cannot account for rise time and fall time on the output pins, dead time still needs to be added to the input signals to compensate for output switching speed. For example, if the high-side and low-side input signals are exactly opposing each other with no dead time, there can be a shoot-through condition during the duration of the output rise time and fall time. An exception to this is [LM5104](#) which uses an adaptive delay system on the output to prevent the outputs from overlapping during rise and fall times by inserting additional adaptive output dead time.

Gate drivers with fixed internal dead time insert a short, fixed time period between the falling edge of one output and the rising edge of the other output. This provides basic shoot-through protection without an additional external set resistor. [LM2103](#) and [LM2104](#) provide 475ns typical fixed dead time.

Adjustable or programmable dead time is a feature of some gate drivers that is usually set by connecting a resistor to a dedicated dead time adjustment pin. Compared to fixed dead time, adjustable timing allows for greater flexibility to minimize deadtime for optimized efficiency while still preventing shoot-through. In a motor drive application, programmable dead time allows for improved control of switching transitions between power devices leading to benefits such as reduced switching losses, improved output transients, and the ability to adapt to different motor and operating conditions. The dead time on [LM5104](#) can be set with a resistor value between 10k Ω and 100k Ω , resulting in an effective dead time proportional to the set resistance and ranging from 90ns to 200ns as shown in [Figure 2-4](#). The dead time for [LM5105](#), and [LM5106](#) can also be set with a resistor value between 10k Ω and 100k Ω to set a delay from 86ns to 510ns as seen in [Figure 2-5](#) showing the timing range from 10k Ω to 150k Ω .

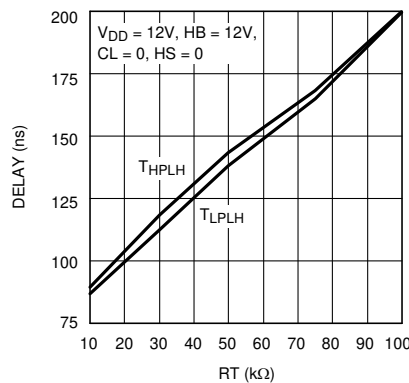

Figure 2-4. LM5104 Dead Time vs RT Resistor Value

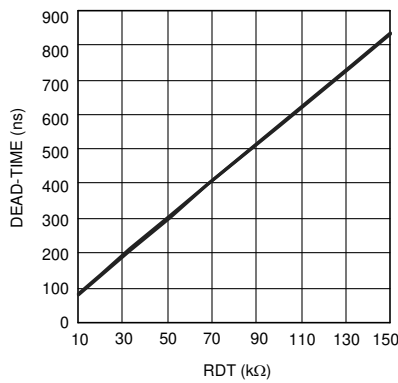

Figure 2-5. LM5105 and LM5106 Dead Time vs RT Resistor Value

A gate driver with adjustable or fixed dead time and interlock control can streamline the microcontroller timing logic by removing the requirement for the microcontroller to maintain safe dead time periods between multiple PWM output signals. The adjustable dead time feature also allows for easy timing changes by simply changing the dead time set resistor without the need to modify the microcontroller programming.

2.4 Integrated Bootstrap Diode

For half-bridge drivers, a floating bias supply referenced to the switch node is required to turn on the high-side transistor. This bias supply is typically created with a bootstrap circuit using a resistor, diode, and capacitor. For more information about the bootstrap circuit and component selection guidance, see [Bootstrap Circuitry Selection for Half-Bridge Configurations](#). Gate drivers with an integrated bootstrap diode can simplify a driver design and save cost and board space by removing the need for external bootstrap diode and resistor components. Figure 2-6 shows an example of the LM2105 gate driver with an integrated bootstrap diode.

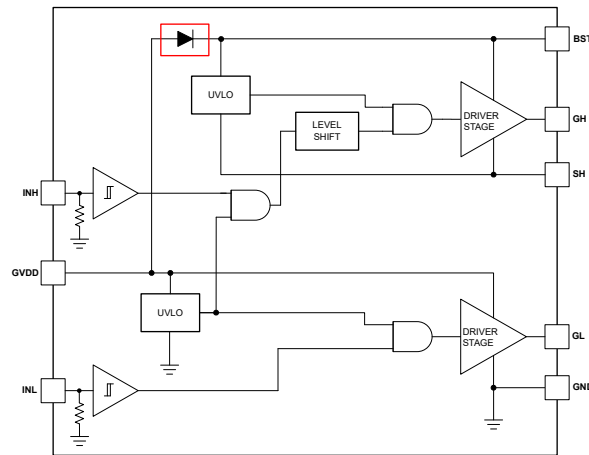

Figure 2-6. LM2105 Block Diagram with Integrated Bootstrap Diode

3 Application Considerations

In appliance applications such as cordless power tools or other home appliances that include a motor drive, important design considerations can include cost, total design size, and ease of use. Device specification considerations can include maximum bootstrap supply voltage, negative voltage transient handling, gate driver VDD supply voltage, undervoltage lockout, and drive current. See [Table 4-1](#) to compare TI gate drivers with single input capability, enable or shutdown pins, fixed or adjustable deadtime, interlock, and integrated bootstrap diode features. [Figure 3-1](#) shows where gate drivers can be used to control multiple BLDC, Permanent Magnet Synchronous Motor (PMSM), or brushed DC (BDC) motors in an application such as cordless vacuum cleaners.

A 100V half-bridge driver such as [LM5106](#) or [LM2105](#) is designed for a small appliance motor drive application. LM5106 has a high absolute maximum bootstrap supply voltage of 118V which supports a 100 % switching voltage transient margin in a 12V VDD system with 12V to 48V motor drive supply. The 1.2A of source current and 1.8A of sink current is designed for DC motor drive switching frequencies and LM5106 also features a single PWM input, enable input, and adjustable dead time in a compact 4x4 mm WSON or 3 × 3mm VSSOP package.

If total design size is a major concern, LM2105 is available in a small 2 × 2mm WSON package with an integrated bootstrap diode. If a leaded package is required, the 5× 4mm SOIC package is available and the lack of need for an external bootstrap diode and resistor reduces the overall footprint. LM2105 also provides sufficient maximum HS pin voltage margin for a typical 12V to 48V motor drive system and high -19.5V negative voltage handling for large negative transients.

Cordless vacuum cleaner

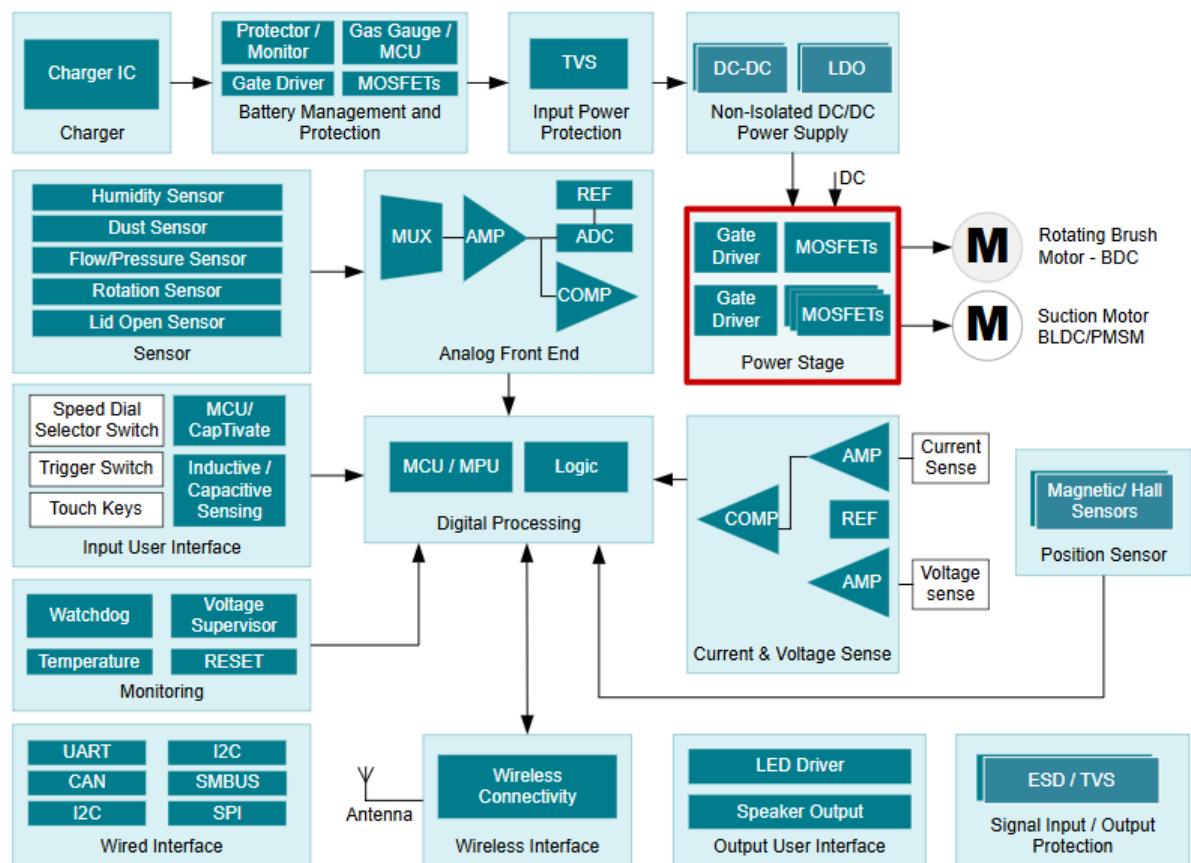

Figure 3-1. Cordless Vacuum Cleaner Appliance Block Diagram

To read more on motor drive applications, see [How to Choose a Gate Driver for DC Motor Drives](#).

4 Summary

Table 4-1 includes gate driver specifications and features that are commonly considered when selecting the proper driver for an application as discussed in this application note. For complete details on the specifications and features of each driver, see the device data sheet.

4.1 Device Summary

Table 4-1. Gate Driver Feature Comparison Table

Features	LM5104	LM5105	LM5106	LM5108	LM2005	LM2103	LM2104	LM2105
Abs. Max Bootstrap Supply Voltage	118V	118V	118V	110V	107V	107V	107V	107V
Abs. Max Minimum HS Transient Voltage	-1V	-5V(1)	(1)	-7V (2)	-19.5V (2)	-19.5V (2)	-19.5V (2)	-19.5V (2)
Input Type	Single Input	Single Input	Single Input	Dual Inputs	Dual Independent Inputs	Inverting and Non-inverting Inputs	Single Input	Dual Independent Inputs
Dead Time or Interlock Protection	Adjustable Dead Time (90ns – 200ns); Adaptive Delay	Adjustable Dead Time (80ns – 570ns)	Adjustable Dead Time (86ns – 510ns)	Interlock	No	Fixed Dead Time (475ns)	Fixed Dead Time (475ns)	No
Integrated Bootstrap Diode	Yes	Yes	No	Yes	Yes	No	No	Yes
Package	5 × 4mm SOIC 4 × 4mm WSON	4 × 4mm WSON	4 × 4mm WSON 3 × 3mm VSSOP	3 × 3mm SON	5 × 4mm SOIC 2 × 2mm WSON	5 × 4mm SOIC	5 × 4mm SOIC	5 × 4mm SOIC 2 × 2mm WSON
Source/Sink Current	1.6A/1.8A	1.8A/1.6A	1.2A/1.8A	1.6A/2.6A	0.5A/0.8A (2)	0.5A/0.8A (2)	0.5A/0.8A (2)	0.5A/0.8A (2)
UVLO	6.9V	6.9V	6.9V	5V	8.15V	8.15V	8.15V	4.6V
Abs. Max VDD Voltage	18V	18V	18V	20V	19.5V	19.5V	19.5V	19.5V
Enable or Shutdown Input	No	Enable Input	Enable Input	Enable Input	No	No	Shutdown Input	No

1. If negative transients occur on HS, the HS voltage must never be more negative than VDD - 15V. For example, if VDD = 10V, the negative transients at HS must not exceed -5V.
2. Values are verified by characterization and are not production tested.

5 References

- Texas Instruments, [How to Choose a Gate Driver for DC Motor Drives](#), application note.
- Texas Instruments, [Applying External Phase Control Circuit for UCC28063](#), application note.
- Texas Instruments, [MOSFET Power Losses and How They Affect Power Supply Efficiency](#), analog applications journal.
- Texas Instruments, [Bootstrap Circuitry Selection for Half Bridge Configurations](#), application note.

IMPORTANT NOTICE AND DISCLAIMER

TI PROVIDES TECHNICAL AND RELIABILITY DATA (INCLUDING DATA SHEETS), DESIGN RESOURCES (INCLUDING REFERENCE DESIGNS), APPLICATION OR OTHER DESIGN ADVICE, WEB TOOLS, SAFETY INFORMATION, AND OTHER RESOURCES "AS IS" AND WITH ALL FAULTS, AND DISCLAIMS ALL WARRANTIES, EXPRESS AND IMPLIED, INCLUDING WITHOUT LIMITATION ANY IMPLIED WARRANTIES OF MERCHANTABILITY, FITNESS FOR A PARTICULAR PURPOSE OR NON-INFRINGEMENT OF THIRD PARTY INTELLECTUAL PROPERTY RIGHTS.

These resources are intended for skilled developers designing with TI products. You are solely responsible for (1) selecting the appropriate TI products for your application, (2) designing, validating and testing your application, and (3) ensuring your application meets applicable standards, and any other safety, security, regulatory or other requirements.

These resources are subject to change without notice. TI grants you permission to use these resources only for development of an application that uses the TI products described in the resource. Other reproduction and display of these resources is prohibited. No license is granted to any other TI intellectual property right or to any third party intellectual property right. TI disclaims responsibility for, and you will fully indemnify TI and its representatives against, any claims, damages, costs, losses, and liabilities arising out of your use of these resources.

TI's products are provided subject to [TI's Terms of Sale](#) or other applicable terms available either on [ti.com](https://www.ti.com) or provided in conjunction with such TI products. TI's provision of these resources does not expand or otherwise alter TI's applicable warranties or warranty disclaimers for TI products.

TI objects to and rejects any additional or different terms you may have proposed.

Mailing Address: Texas Instruments, Post Office Box 655303, Dallas, Texas 75265

Copyright © 2025, Texas Instruments Incorporated