



## ABSTRACT

This report discusses the radiation characterization results of the INA951-SEP current-sense amplifier. The study was done to determine Total Ionizing Dose (TID) effects under high dose rate (HDR) up to 30krad(Si). The results show that all samples passed within the specified limits up to 30krad(Si). To specify the following results, the Radiation Lot Acceptance Testing (RLAT) was performed using five units at a dose level of 30krad(Si) that are required for future wafer lots. Furthermore, the INA951 is packaged in a space enhanced plastic for low outgassing characteristics and is Single Event Latch-Up (SEL) immune up to 47MeV-cm<sup>2</sup> /mg making the device designed for low Earth orbit space applications.

---

## Table of Contents

|  |   |
|--|---|
| <b>1 Device Information</b> .....                                      | 2 |
| 1.1 Device Details.....  | 2 |
| <b>2 Total Dose Test Setup</b> .....                                   | 3 |
| 2.1 Test Overview.....   | 3 |
| 2.2 Test Description and Facilities.....                               | 3 |
| 2.3 Test Setup Details.....  | 3 |
| 2.3.1 Biased.....  | 3 |
| 2.4 Test Configuration and Condition.....                              | 3 |
| <b>3 Total Ionizing Dose (RHA) Characterization Test Results</b> ..... | 4 |
| 3.1 Total Ionizing Dose RHA Characterization Summary Results.....      | 4 |
| 3.2 Specification Compliance Matrix.....                               | 4 |
| <b>4 Total Ionizing Dose Report</b> .....                              | 6 |

## Trademarks

All trademarks are the property of their respective owners.

## 1 Device Information

The INA951-SEP is a radiation-tolerant, ultra-precise current-sense amplifier that measures voltage drops across shunt resistors over a common-mode range of  $-4$  to  $80V$ . The INA951-SEP operates from a single  $2.7V$  to  $10V$  supply drawing  $1.5mA$  of a supply current.

### 1.1 Device Details

[Table 1-1](#) lists the device information used for TID HDR characterization and qualification.

**Table 1-1. Device and Exposure Details**

| TID HDR Details: Up to 30krad (Si) |   |
|------------------------------------|---|
| TI Device Number                   | INA951-SEP                                  |
| Package                            | 8-pin PW                                    |
| Technology                         | LBCSOI2                                     |
| Die Lot Number                     | 5217124                                     |
| A/T Lot Number / Lot Trace Code    | 5640552 / 5CA7KEW                           |
| Quantity Tested                    | 15 irradiated devices and 2 control devices |
| Lot Accept/Reject                  | Devices passed 30krad (Si)                  |
| HDR Radiation Facility             | Texas Instruments CLAB, Dallas, TX          |
| HDR Dose Level                     | 30krad (Si)                                 |
| HDR Dose Rate                      | 260rad(Si)                                  |
| HDR Radiation Source               | Gammacell (GR420) Co-60                     |
| Irradiation Temperature            | Ambient, room temperature                   |
| VID                                | V62/25635                                   |



**Figure 1-1. INA951-SEP Device**

## 2 Total Dose Test Setup

### 2.1 Test Overview

#### HDR Testing

The INA951-SEP samples were irradiated at a high dose rate of 50-300 rad(Si)/s up to 30krad(Si) and then put through full electrical parametric testing on the production Automated Test Equipment (ATE). The samples were functional and passed all electrical parametric tests with readings within datasheet electrical specification limits.

#### 2.2 Test Description and Facilities

The INA951-SEP HDR exposure was performed on biased devices in a Co60 gamma cell at TI CLAB facility in Dallas, Texas. The unattenuated dose rate of this cell is 50-300rad(Si)/s. After exposure, the devices completed a full post irradiation electrical evaluation using Texas Instruments ATE. The ATE guard band test limits are set within the electrical specifications in the datasheet to ensure a minimum Cpk and test error margin based on initial qualification and characterization data. Post-irradiation measurements were taken within 30 minutes of radiation.

#### 2.3 Test Setup Details

The devices were tested in biased conditions as shown in the following sections.

##### 2.3.1 Biased

Figure 2-1 shows the bias conditions for each pin during irradiation.

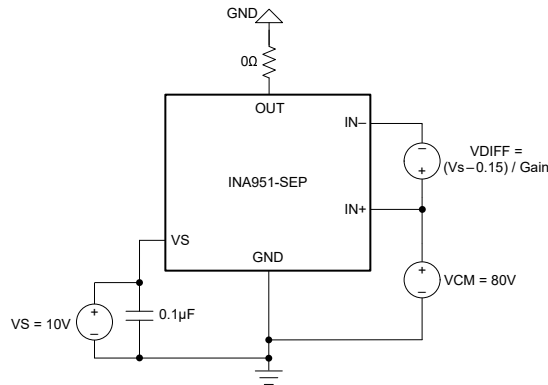

Figure 2-1. INA951-SEP Biased Diagram

#### 2.4 Test Configuration and Condition

Devices at HDR were stressed at 30krad(Si) for biased and unbiased conditions.

End point electrical test is performed on irradiated devices to verify they are within specified SMD electrical test limits. MIL-STD-883, Test Method 1019.9, Condition D is used in this case.

Table 2-1 shows the serialized samples used for HDR RHA characterization.

Table 2-1. HDR = 260rad(Si)/s Device Information

| HDR = 260rad(Si)/s |                |
|--------------------|----------------|
| Total Samples: 10  |                |
| Exposure Levels    |                |
| 30krad (Si)        | 30krad (Si)    |
| Biased             | Unbiased       |
| 1, 2, 3, 4, 5      | 6, 7, 8, 9, 10 |

### 3 Total Ionizing Dose (RHA) Characterization Test Results

#### 3.1 Total Ionizing Dose RHA Characterization Summary Results

The parametric data for the INA951-SEP is within datasheet limits up to 30krad(Si) for biased setup conditions.

#### 3.2 Specification Compliance Matrix

**Table 3-1. Electrical Parameters Table**

| Parameter                 |  | Test Conditions   | MIN | TYP          | MAX          | Unit                           | Test Name/Number    |
|---------------------------|--|---|-----|--------------|--------------|--------------------------------|---------------------|
| <b>INPUT</b>              |  |   |     |              |              |                                |                     |
| $V_{CM}$                  | Common-mode input range                      | $T_A = -55^{\circ}\text{C}$ to $+125^{\circ}\text{C}$   | -4  |              | 80           | V                              |                     |
| CMRR                      | Common-mode rejection ratio, input referred  | $-4\text{V} \leq V_{CM} \leq 80\text{V}$ , $T_A = -55^{\circ}\text{C}$ to $125^{\circ}\text{C}$                 | -99 |              | -99          | nV/V                           | 80.10, 80.11        |
|                           |  | $F = 50\text{kHz}$  | -99 | 8            | 99           |                                |                     |
| $V_{OS}$                  | Offset voltage, input referred               |   |     | $\pm 30$     | $\pm 150$    | $\mu\text{V}$                  | 61.0                |
| $dV_{OS}/dT$              | Offset voltage drift                         | $T_A = -55^{\circ}\text{C}$ to $+125^{\circ}\text{C}$   |     | $\pm 0.05$   |              | $\mu\text{V}/^{\circ}\text{C}$ |                     |
| PSRR                      | Power supply rejection ratio, input referred | $2.7\text{V} \leq V_S \leq 10\text{V}$ , $T_A = -55^{\circ}\text{C}$ to $+125^{\circ}\text{C}$                  |     | $\pm 1$      | $\pm 8$      | $\mu\text{V}/\text{V}$         | 71.4                |
| $I_B$                     | Input bias current                           | $I_{B+}$ , $V_{SENSE} = 0\text{V}$  | 10  | 20           | 30           | $\mu\text{A}$                  | 20.1, 20.2          |
|                           |  | $I_{B-}$ , $V_{SENSE} = 0\text{V}$  | 10  | 20           | 30           |                                |                     |
| <b>OUTPUT</b>             |  |   |     |              |              |                                |                     |
| G                         | Gain   |   |     | 20           |              | V/V                            | 51.4                |
| $G_{ERR}$                 | Gain error                                   | $\text{GND} + 50\text{mV} \leq V_{OUT} \leq V_S - 200\text{mV}$   |     | $\pm 0.02$   | $\pm 0.15$   | %                              | 51.5                |
|                           |  | $T_A = -55^{\circ}\text{C}$ to $+125^{\circ}\text{C}$   |     | $\pm 0.01$   |              | ppm/ $^{\circ}\text{C}$        |                     |
| $NL_{ERR}$                | Nonlinearity error                           |   |     | 0.01         |              | %                              |                     |
|                           | Maximum capacitive load                      | No sustained oscillations, no isolation resistor  |     | 500          |              | pF                             |                     |
| <b>VOLTAGE OUTPUT</b>     |  |   |     |              |              |                                |                     |
|                           | Swing to $V_S$ (Power supply rail)           | $R_{LOAD} = 10\text{k}\Omega$ , $T_A = -55^{\circ}\text{C}$ to $+125^{\circ}\text{C}$                           |     | $V_S - 0.07$ | $V_S - 0.05$ | V                              | 110.0, 120.0, 130.0 |
|                           | Swing to ground                              | $R_{LOAD} = 10\text{k}\Omega$ , $V_{SENSE} = 0\text{V}$ , $T_A = -55^{\circ}\text{C}$ to $+125^{\circ}\text{C}$ |     | 0.005        | 0.02         | V                              | 90.0                |
| <b>FREQUENCY RESPONSE</b> |  |   |     |              |              |                                |                     |
| BW                        | Bandwidth                                    | $C_{LOAD} = 5\text{pF}$ , $V_{SENSE} = 200\text{mV}$  |     | 1300         |              | kHz                            |                     |
| SR                        | Slew rate                                    | Rising edge   |     | 2.5          |              | V/ $\mu\text{S}$               |                     |
|                           | Settling time                                | $V_{OUT} = 4\text{V} \mp 0.1$ step, Output settles to 0.5%  |     | 10           |              | $\mu\text{S}$                  |                     |
|                           |  | $V_{OUT} = 4\text{V} \mp 0.1$ step, Output settles to 1%  |     | 5            |              |                                |                     |
|                           |  | $V_{OUT} = 4\text{V} \mp 0.1$ step, Output settles to 5%  |     | 1            |              |                                |                     |
| <b>NOISE</b>              |  |   |     |              |              |                                |                     |

**Table 3-1. Electrical Parameters Table (continued)**

| Parameter           |                       | Test Conditions                  | MIN | TYP | MAX  | Unit                   | Test Name/Number |
|---------------------|-----------------------|----------------------------------|-----|-----|------|------------------------|------------------|
| V <sub>EN</sub>     | Voltage noise density |                                  |     | 50  |      | nV/ $\sqrt{\text{Hz}}$ |                  |
| <b>POWER SUPPLY</b> |                       |                                  |     |     |      |                        |                  |
| V <sub>S</sub>      | Supply voltage        | T <sub>A</sub> = -55°C to +125°C | 2.7 |     | 10   | V                      |                  |
| I <sub>Q</sub>      | Quiescent current     |                                  |     | 1.5 | 2    | mA                     | 30.0, 30.1, 30.2 |
|                     |                       | T <sub>A</sub> = -55°C to +125°C |     |     | 2.25 |                        |                  |

## **A Total Ionizing Dose Report**

This appendix provides the INA951-SEP TID HDR report. The reports show the variation for each parameter up to 30krad(Si).

Delta Threshold 10.00%

TID Report  
INA951-SEP

TID Report  
INA951-SEP

20.0\_n20CM\_IQ\_VS\_5p0\_48V\_0

|             |           |           |
|-------------|-----------|-----------|
| Test Site   | J2S       | J2S       |
| Tester      | FETS36401 | FETS36417 |
| Test Number | EE213301  | EE213301  |
| Unit        | uA        | uA        |
| Max Limit   | 90        | 90        |
| Min Limit   | -90       | -90       |

| krad    | Serial # | pre   | Post.log | Delta |
|---------|----------|-------|----------|-------|
| 0       | 1        | 6.374 | 0.584    | 5.790 |
| 0       | 2        | 5.790 | -1.362   | 7.152 |
| 30      | 3        | 4.671 | 1.751    | 2.920 |
| 30      | 4        | 4.622 | 0.243    | 4.379 |
| 30      | 5        | 3.211 | 1.897    | 1.314 |
| 30      | 6        | 4.574 | 1.702    | 2.872 |
| 30      | 7        | 4.038 | -0.389   | 4.427 |
| 30      | 8        | 3.941 | -0.340   | 4.281 |
| 30      | 9        | 3.746 | 0.924    | 2.822 |
| 30      | 10       | 3.552 | -0.097   | 3.649 |
| 30      | 11       | 3.552 | 0.292    | 3.260 |
| 30      | 12       | 4.038 | 0.632    | 3.406 |
| Max     |          | 6.374 | 1.897    | 7.152 |
| Average |          | 4.342 | 0.486    | 3.856 |
| Min     |          | 3.211 | -1.362   | 1.314 |
| Std Dev |          | 0.939 | 0.981    | 1.518 |

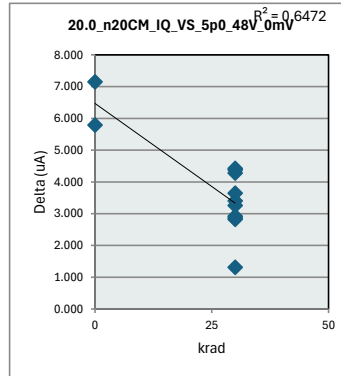

20.0\_n20CM\_IQ\_VS\_5p0\_48V

|             |                 |
|-------------|-----------------|
| Test Site   | J2S             |
| Tester      | FETS36401       |
| Test Number | EE213301        |
| Max Limit   | 90 uA           |
| Min Limit   | -90 uA          |
| krad        | 0 30            |
| LL          | -90.000 -90.000 |
| Min         | -1.362 -0.389   |
| Average     | -0.389 0.662    |
| Max         | 0.584 1.897     |
| UL          | 90.000 90.000   |

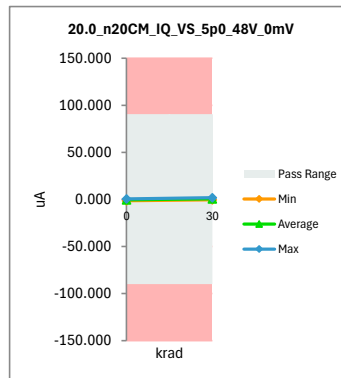

TID Report  
INA951-SEP

| 20.1_n20CM_IB_Pos_VS_5p0_48V_0mV |           |           |
|----------------------------------|-----------|-----------|
| Test Site                        | J2S       | J2S       |
| Tester                           | FETS36401 | FETS36417 |
| Test Number                      | EE213301  | EE213301  |
| Unit                             | uA        | uA        |
| Max Limit                        | 5         | 5         |
| Min Limit                        | -5        | -5        |

| krad    | Serial # | pre    | Post.log | Delta |
|---------|----------|--------|----------|-------|
| 0       | 1        | -0.033 | -0.172   | 0.139 |
| 0       | 2        | -0.054 | -0.171   | 0.117 |
| 30      | 3        | -0.042 | -0.162   | 0.120 |
| 30      | 4        | -0.025 | -0.171   | 0.146 |
| 30      | 5        | -0.044 | -0.172   | 0.128 |
| 30      | 6        | -0.058 | -0.130   | 0.072 |
| 30      | 7        | -0.036 | -0.171   | 0.135 |
| 30      | 8        | -0.014 | -0.180   | 0.166 |
| 30      | 9        | -0.028 | -0.159   | 0.131 |
| 30      | 10       | -0.052 | -0.159   | 0.107 |
| 30      | 11       | -0.021 | -0.162   | 0.141 |
| 30      | 12       | 0.001  | -0.155   | 0.156 |
| Max     |          | 0.001  | -0.130   | 0.166 |
| Average |          | -0.034 | -0.164   | 0.130 |
| Min     |          | -0.058 | -0.180   | 0.072 |
| Std Dev |          | 0.018  | 0.013    | 0.025 |

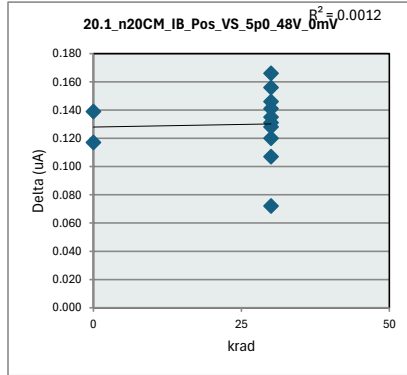

| 20.1_n20CM_IB_Pos_VS_5p0 |           |        |
|--------------------------|-----------|--------|
| Test Site                | J2S       |        |
| Tester                   | FETS36401 |        |
| Test Number              | EE213301  |        |
| Max Limit                | 5         | uA     |
| Min Limit                | -5        | uA     |
| krad                     | 0         | 30     |
| LL                       | -5.000    | -5.000 |
| Min                      | -0.172    | -0.180 |
| Average                  | -0.172    | -0.162 |
| Max                      | -0.171    | -0.130 |
| UL                       | 5.000     | 5.000  |

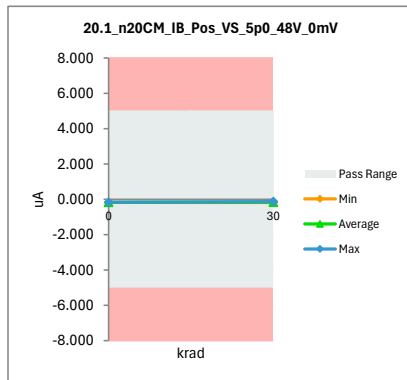

TID Report  
INA951-SEP

20.2\_n20CM\_IB\_Neg\_VS\_5p0\_4

|             |           |           |
|-------------|-----------|-----------|
| Test Site   | J2S       | J2S       |
| Tester      | FETS36401 | FETS36417 |
| Test Number | EE213301  | EE213301  |
| Unit        | uA        | uA        |
| Max Limit   | 5         | 5         |
| Min Limit   | -5        | -5        |

| krad    | Serial # | pre    | Post.log | Delta  |
|---------|----------|--------|----------|--------|
| 0       | 1        | -0.247 | 0.109    | -0.356 |
| 0       | 2        | -0.272 | 0.023    | -0.295 |
| 30      | 3        | -0.113 | 0.047    | -0.160 |
| 30      | 4        | -0.187 | 0.045    | -0.232 |
| 30      | 5        | -0.218 | 0.075    | -0.293 |
| 30      | 6        | -0.077 | 0.041    | -0.118 |
| 30      | 7        | -0.101 | 0.038    | -0.139 |
| 30      | 8        | -0.290 | 0.071    | -0.361 |
| 30      | 9        | -0.190 | 0.077    | -0.267 |
| 30      | 10       | -0.177 | 0.052    | -0.229 |
| 30      | 11       | -0.222 | 0.046    | -0.268 |
| 30      | 12       | -0.304 | 0.056    | -0.360 |
| Max     |          | -0.077 | 0.109    | -0.118 |
| Average |          | -0.200 | 0.057    | -0.256 |
| Min     |          | -0.304 | 0.023    | -0.361 |
| Std Dev |          | 0.074  | 0.023    | 0.084  |

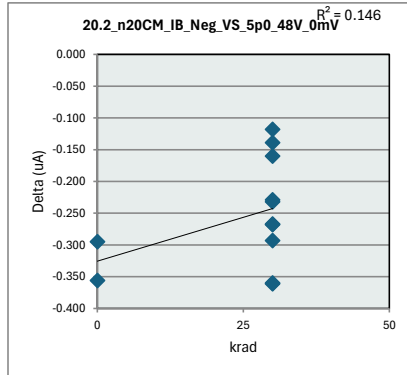

20.2\_n20CM\_IB\_Neg\_VS\_5p0

|             |               |
|-------------|---------------|
| Test Site   | J2S           |
| Tester      | FETS36401     |
| Test Number | EE213301      |
| Max Limit   | 5 uA          |
| Min Limit   | -5 uA         |
| krad        | 0 30          |
| LL          | -5.000 -5.000 |
| Min         | 0.023 0.038   |
| Average     | 0.066 0.055   |
| Max         | 0.109 0.077   |
| UL          | 5.000 5.000   |

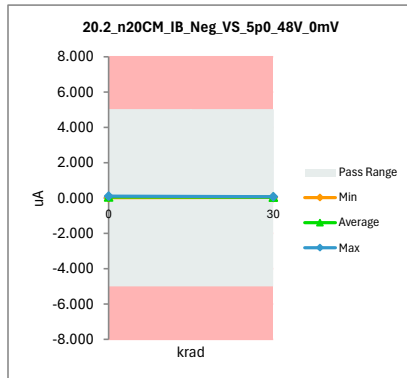

TID Report  
INA951-SEP

**30.0\_IQ\_VS\_2p7V\_48V\_25mV**

|             |           |           |
|-------------|-----------|-----------|
| Test Site   | J2S       | J2S       |
| Tester      | FETS36401 | FETS36417 |
| Test Number | EE213301  | EE213301  |
| Unit        | mA        | mA        |
| Max Limit   | 1.99      | 1.99      |
| Min Limit   | 0.81      | 0.81      |

| krad    | Serial # | pre   | Post.log | Delta  |
|---------|----------|-------|----------|--------|
| 0       | 1        | 1.067 | 1.067    | 0.000  |
| 0       | 2        | 1.081 | 1.082    | -0.001 |
| 30      | 3        | 1.077 | 1.073    | 0.004  |
| 30      | 4        | 1.099 | 1.089    | 0.010  |
| 30      | 5        | 1.089 | 1.074    | 0.015  |
| 30      | 6        | 1.062 | 1.049    | 0.013  |
| 30      | 7        | 1.097 | 1.095    | 0.002  |
| 30      | 8        | 1.078 | 1.075    | 0.003  |
| 30      | 9        | 1.097 | 1.094    | 0.003  |
| 30      | 10       | 1.085 | 1.070    | 0.015  |
| 30      | 11       | 1.070 | 1.061    | 0.009  |
| 30      | 12       | 1.061 | 1.057    | 0.004  |
| Max     |          | 1.099 | 1.095    | 0.015  |
| Average |          | 1.080 | 1.074    | 0.006  |
| Min     |          | 1.061 | 1.049    | -0.001 |
| Std Dev |          | 0.014 | 0.014    | 0.006  |

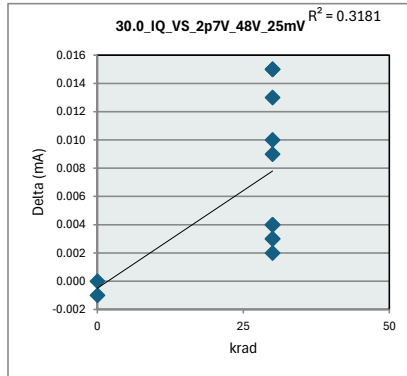

**30.0\_IQ\_VS\_2p7V\_48V\_25mV**

|             |             |
|-------------|-------------|
| Test Site   | J2S         |
| Tester      | FETS36401   |
| Test Number | EE213301    |
| Max Limit   | 1.99 mA     |
| Min Limit   | 0.81 mA     |
| krad        | 0 30        |
| LL          | 0.810 0.810 |
| Min         | 1.067 1.049 |
| Average     | 1.075 1.074 |
| Max         | 1.082 1.095 |
| UL          | 1.990 1.990 |

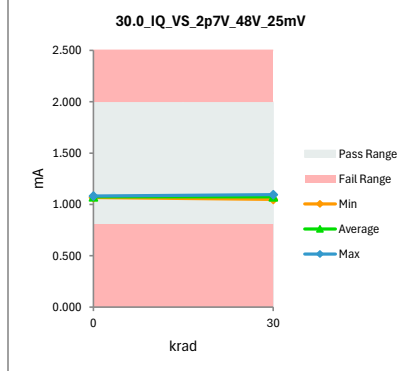

TID Report  
INA951-SEP

**30.1\_IQ\_VS\_5p0V\_48V\_25mV**

|             |           |           |
|-------------|-----------|-----------|
| Test Site   | J2S       | J2S       |
| Tester      | FETS36401 | FETS36417 |
| Test Number | EE213301  | EE213301  |
| Unit        | mA        | mA        |
| Max Limit   | 1.99      | 1.99      |
| Min Limit   | 0.81      | 0.81      |

| krad    | Serial # | pre   | Post.log | Delta  |
|---------|----------|-------|----------|--------|
| 0       | 1        | 1.453 | 1.454    | -0.001 |
| 0       | 2        | 1.491 | 1.491    | 0.000  |
| 30      | 3        | 1.484 | 1.496    | -0.012 |
| 30      | 4        | 1.499 | 1.517    | -0.018 |
| 30      | 5        | 1.507 | 1.516    | -0.009 |
| 30      | 6        | 1.452 | 1.460    | -0.008 |
| 30      | 7        | 1.469 | 1.488    | -0.019 |
| 30      | 8        | 1.497 | 1.503    | -0.006 |
| 30      | 9        | 1.508 | 1.511    | -0.003 |
| 30      | 10       | 1.453 | 1.447    | 0.006  |
| 30      | 11       | 1.502 | 1.505    | -0.003 |
| 30      | 12       | 1.446 | 1.452    | -0.006 |
| Max     |          | 1.508 | 1.517    | 0.006  |
| Average |          | 1.480 | 1.487    | -0.007 |
| Min     |          | 1.446 | 1.447    | -0.019 |
| Std Dev |          | 0.024 | 0.026    | 0.007  |

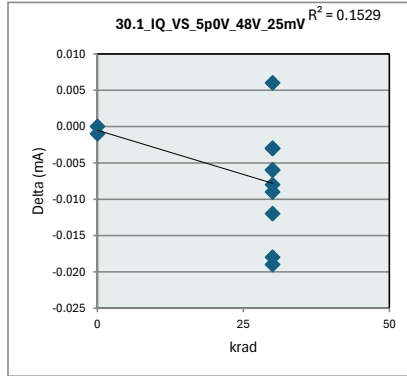

**30.1\_IQ\_VS\_5p0V\_48V\_25mV**

|             |             |
|-------------|-------------|
| Test Site   | J2S         |
| Tester      | FETS36401   |
| Test Number | EE213301    |
| Max Limit   | 1.99 mA     |
| Min Limit   | 0.81 mA     |
| krad        | 0 30        |
| LL          | 0.810 0.810 |
| Min         | 1.454 1.447 |
| Average     | 1.473 1.490 |
| Max         | 1.491 1.517 |
| UL          | 1.990 1.990 |

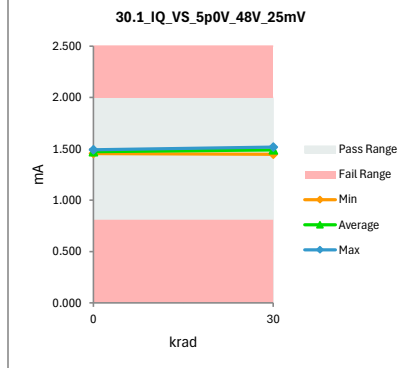

TID Report  
INA951-SEP

**30.2\_IQ\_VS\_10p0V\_48V\_25mV**

|             |           |           |
|-------------|-----------|-----------|
| Test Site   | J2S       | J2S       |
| Tester      | FETS36401 | FETS36417 |
| Test Number | EE213301  | EE213301  |
| Unit        | mA        | mA        |
| Max Limit   | 1.99      | 1.99      |
| Min Limit   | 0.81      | 0.81      |

| krad    | Serial # | pre   | Post.log | Delta  |
|---------|----------|-------|----------|--------|
| 0       | 1        | 1.475 | 1.476    | -0.001 |
| 0       | 2        | 1.514 | 1.514    | 0.000  |
| 30      | 3        | 1.500 | 1.512    | -0.012 |
| 30      | 4        | 1.522 | 1.536    | -0.014 |
| 30      | 5        | 1.527 | 1.534    | -0.007 |
| 30      | 6        | 1.474 | 1.478    | -0.004 |
| 30      | 7        | 1.491 | 1.508    | -0.017 |
| 30      | 8        | 1.516 | 1.524    | -0.008 |
| 30      | 9        | 1.529 | 1.532    | -0.003 |
| 30      | 10       | 1.475 | 1.466    | 0.009  |
| 30      | 11       | 1.520 | 1.522    | -0.002 |
| 30      | 12       | 1.466 | 1.469    | -0.003 |
| Max     |          | 1.529 | 1.536    | 0.009  |
| Average |          | 1.501 | 1.506    | -0.005 |
| Min     |          | 1.466 | 1.466    | -0.017 |
| Std Dev |          | 0.023 | 0.026    | 0.007  |

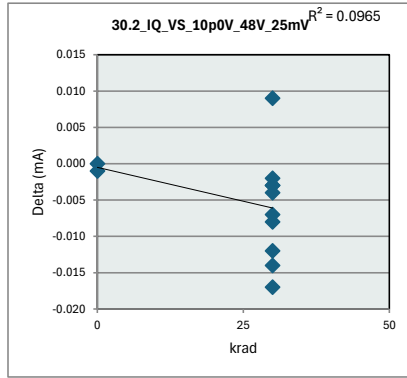

**30.2\_IQ\_VS\_10p0V\_48V\_25m**

|             |             |
|-------------|-------------|
| Test Site   | J2S         |
| Tester      | FETS36401   |
| Test Number | EE213301    |
| Max Limit   | 1.99 mA     |
| Min Limit   | 0.81 mA     |
| krad        | 0 30        |
| LL          | 0.810 0.810 |
| Min         | 1.476 1.466 |
| Average     | 1.495 1.508 |
| Max         | 1.514 1.536 |
| UL          | 1.990 1.990 |

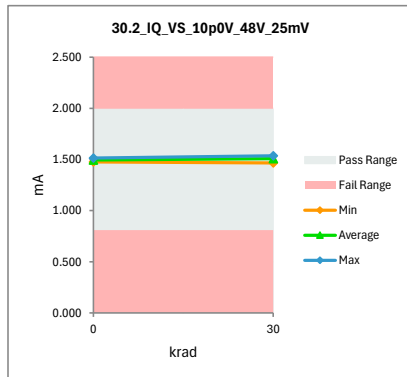

TID Report  
INA951-SEP

| 40.0_IB_Pos_VS_5p0V_48V_0m |           |           |
|----------------------------|-----------|-----------|
| Test Site                  | J2S       | J2S       |
| Tester                     | FETS36401 | FETS36417 |
| Test Number                | EE213301  | EE213301  |
| Unit                       | uA        | uA        |
| Max Limit                  | 21.7      | 21.7      |
| Min Limit                  | 12        | 12        |

| krad    | Serial # | pre    | Post.log | Delta  |
|---------|----------|--------|----------|--------|
| 0       | 1        | 18.449 | 18.468   | -0.019 |
| 0       | 2        | 18.887 | 18.894   | -0.007 |
| 30      | 3        | 18.694 | 18.803   | -0.109 |
| 30      | 4        | 19.526 | 19.459   | 0.067  |
| 30      | 5        | 18.863 | 18.668   | 0.195  |
| 30      | 6        | 18.816 | 18.566   | 0.250  |
| 30      | 7        | 19.218 | 19.317   | -0.099 |
| 30      | 8        | 18.814 | 18.828   | -0.014 |
| 30      | 9        | 19.146 | 19.201   | -0.055 |
| 30      | 10       | 18.633 | 18.566   | 0.067  |
| 30      | 11       | 18.429 | 18.372   | 0.057  |
| 30      | 12       | 18.097 | 18.139   | -0.042 |
| Max     |          | 19.526 | 19.459   | 0.250  |
| Average |          | 18.798 | 18.773   | 0.024  |
| Min     |          | 18.097 | 18.139   | -0.109 |
| Std Dev |          | 0.385  | 0.396    | 0.110  |

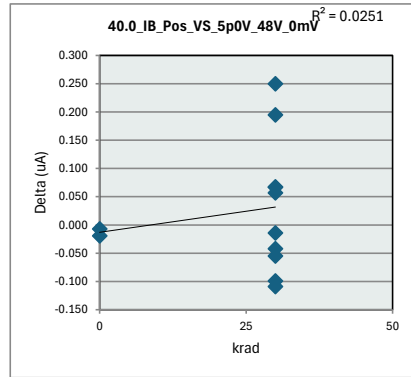

| 40.0_IB_Pos_VS_5p0V_48V_0 |           |        |
|---------------------------|-----------|--------|
| Test Site                 | J2S       |        |
| Tester                    | FETS36401 |        |
| Test Number               | EE213301  |        |
| Max Limit                 | 21.7      | uA     |
| Min Limit                 | 12        | uA     |
| krad                      | 0         | 30     |
| LL                        | 12.000    | 12.000 |
| Min                       | 18.468    | 18.139 |
| Average                   | 18.681    | 18.792 |
| Max                       | 18.894    | 19.459 |
| UL                        | 21.700    | 21.700 |

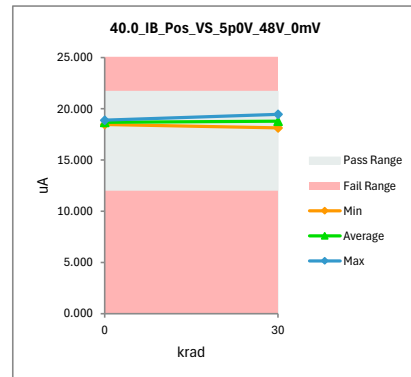

TID Report  
INA951-SEP

40.1\_IB\_Neg\_VS\_5p0V\_48V\_0mV

|             |           |           |
|-------------|-----------|-----------|
| Test Site   | J2S       | J2S       |
| Tester      | FETS36401 | FETS36417 |
| Test Number | EE213301  | EE213301  |
| Unit        | uA        | uA        |
| Max Limit   | 21.7      | 21.7      |
| Min Limit   | 12        | 12        |

| krad    | Serial # | pre    | Post.log | Delta  |
|---------|----------|--------|----------|--------|
| 0       | 1        | 18.527 | 18.396   | 0.131  |
| 0       | 2        | 18.915 | 18.840   | 0.075  |
| 30      | 3        | 18.784 | 18.796   | -0.012 |
| 30      | 4        | 19.598 | 19.410   | 0.188  |
| 30      | 5        | 18.858 | 18.601   | 0.257  |
| 30      | 6        | 18.838 | 18.512   | 0.326  |
| 30      | 7        | 19.296 | 19.245   | 0.051  |
| 30      | 8        | 18.821 | 18.789   | 0.032  |
| 30      | 9        | 19.196 | 19.163   | 0.033  |
| 30      | 10       | 18.632 | 18.513   | 0.119  |
| 30      | 11       | 18.478 | 18.279   | 0.199  |
| 30      | 12       | 18.134 | 18.077   | 0.057  |
| Max     |          | 19.598 | 19.410   | 0.326  |
| Average |          | 18.840 | 18.718   | 0.121  |
| Min     |          | 18.134 | 18.077   | -0.012 |
| Std Dev |          | 0.392  | 0.403    | 0.103  |

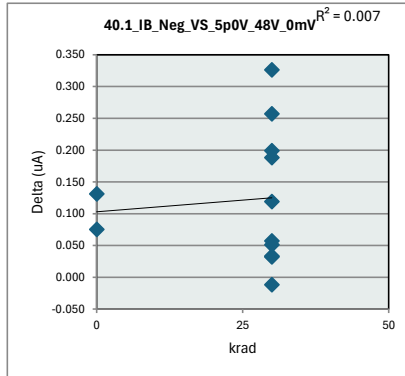

40.1\_IB\_Neg\_VS\_5p0V\_48V\_0mV

|             |               |
|-------------|---------------|
| Test Site   | J2S           |
| Tester      | FETS36401     |
| Test Number | EE213301      |
| Max Limit   | 21.7 uA       |
| Min Limit   | 12 uA         |
| krad        | 0 30          |
| LL          | 12.000 12.000 |
| Min         | 18.396 18.077 |
| Average     | 18.618 18.739 |
| Max         | 18.840 19.410 |
| UL          | 21.700 21.700 |

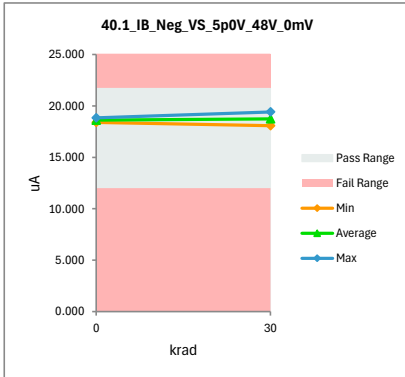

TID Report  
INA951-SEP

| 45.0_IB_Pos_VS_5p0V_60V_0m |           |           |
|----------------------------|-----------|-----------|
| Test Site                  | J2S       | J2S       |
| Tester                     | FETS36401 | FETS36417 |
| Test Number                | EE213301  | EE213301  |
| Unit                       | uA        | uA        |
| Max Limit                  | 21.7      | 21.7      |
| Min Limit                  | 12        | 12        |

| krad    | Serial # | pre    | Post.log | Delta  |
|---------|----------|--------|----------|--------|
| 0       | 1        | 18.408 | 18.501   | -0.093 |
| 0       | 2        | 18.855 | 18.937   | -0.082 |
| 30      | 3        | 18.654 | 18.828   | -0.174 |
| 30      | 4        | 19.500 | 19.489   | 0.011  |
| 30      | 5        | 18.828 | 18.690   | 0.138  |
| 30      | 6        | 18.758 | 18.607   | 0.151  |
| 30      | 7        | 19.185 | 19.333   | -0.148 |
| 30      | 8        | 18.757 | 18.868   | -0.111 |
| 30      | 9        | 19.113 | 19.233   | -0.120 |
| 30      | 10       | 18.590 | 18.584   | 0.006  |
| 30      | 11       | 18.378 | 18.394   | -0.016 |
| 30      | 12       | 18.067 | 18.144   | -0.077 |
| Max     |          | 19.500 | 19.489   | 0.151  |
| Average |          | 18.758 | 18.801   | -0.043 |
| Min     |          | 18.067 | 18.144   | -0.174 |
| Std Dev |          | 0.388  | 0.399    | 0.105  |

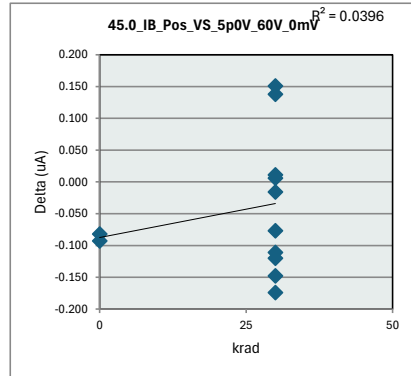

| 45.0_IB_Pos_VS_5p0V_60V_0 |           |        |
|---------------------------|-----------|--------|
| Test Site                 | J2S       |        |
| Tester                    | FETS36401 |        |
| Test Number               | EE213301  |        |
| Max Limit                 | 21.7      | uA     |
| Min Limit                 | 12        | uA     |
| krad                      | 0         | 30     |
| LL                        | 12.000    | 12.000 |
| Min                       | 18.501    | 18.144 |
| Average                   | 18.719    | 18.817 |
| Max                       | 18.937    | 19.489 |
| UL                        | 21.700    | 21.700 |

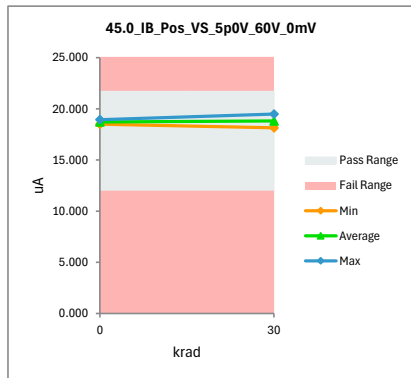

TID Report  
INA951-SEP

45.1\_IB\_Neg\_VS\_5p0V\_60V\_0mV

|             |           |           |
|-------------|-----------|-----------|
| Test Site   | J2S       | J2S       |
| Tester      | FETS36401 | FETS36417 |
| Test Number | EE213301  | EE213301  |
| Unit        | uA        | uA        |
| Max Limit   | 21.7      | 21.7      |
| Min Limit   | 12        | 12        |

| krad    | Serial # | pre    | Post.log | Delta  |
|---------|----------|--------|----------|--------|
| 0       | 1        | 18.455 | 18.371   | 0.084  |
| 0       | 2        | 18.857 | 18.809   | 0.048  |
| 30      | 3        | 18.689 | 18.711   | -0.022 |
| 30      | 4        | 19.541 | 19.364   | 0.177  |
| 30      | 5        | 18.876 | 18.575   | 0.301  |
| 30      | 6        | 18.836 | 18.494   | 0.342  |
| 30      | 7        | 19.229 | 19.224   | 0.005  |
| 30      | 8        | 18.817 | 18.748   | 0.069  |
| 30      | 9        | 19.143 | 19.099   | 0.044  |
| 30      | 10       | 18.636 | 18.464   | 0.172  |
| 30      | 11       | 18.431 | 18.269   | 0.162  |
| 30      | 12       | 18.070 | 18.019   | 0.051  |
| Max     |          | 19.541 | 19.364   | 0.342  |
| Average |          | 18.798 | 18.679   | 0.119  |
| Min     |          | 18.070 | 18.019   | -0.022 |
| Std Dev |          | 0.392  | 0.399    | 0.114  |

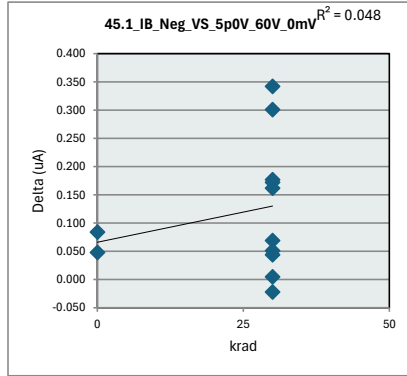

45.1\_IB\_Neg\_VS\_5p0V\_60V\_0mV

|             |                    |
|-------------|--------------------|
| Test Site   | J2S                |
| Tester      | FETS36401          |
| Test Number | EE213301           |
| Max Limit   | 21.7 uA            |
| Min Limit   | 12 uA              |
| krad        | 0      30          |
| LL          | 12.000      12.000 |
| Min         | 18.371      18.019 |
| Average     | 18.590      18.697 |
| Max         | 18.809      19.364 |
| UL          | 21.700      21.700 |

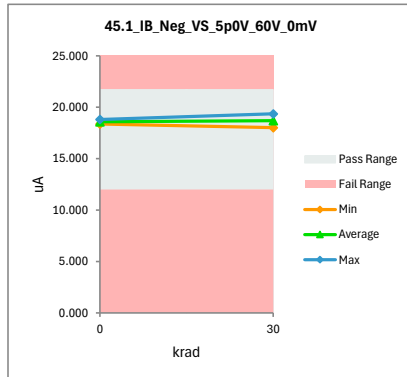

TID Report  
INA951-SEP

45.2\_IB\_Pos\_VS\_5p0V\_80V\_0m

|             |           |           |
|-------------|-----------|-----------|
| Test Site   | J2S       | J2S       |
| Tester      | FETS36401 | FETS36417 |
| Test Number | EE213301  | EE213301  |
| Unit        | uA        | uA        |
| Max Limit   | 21.7      | 21.7      |
| Min Limit   | 12        | 12        |

| krad    | Serial # | pre    | Post.log | Delta  |
|---------|----------|--------|----------|--------|
| 0       | 1        | 18.409 | 18.444   | -0.035 |
| 0       | 2        | 18.841 | 18.865   | -0.024 |
| 30      | 3        | 18.658 | 18.771   | -0.113 |
| 30      | 4        | 19.500 | 19.435   | 0.065  |
| 30      | 5        | 18.818 | 18.642   | 0.176  |
| 30      | 6        | 18.783 | 18.540   | 0.243  |
| 30      | 7        | 19.192 | 19.294   | -0.102 |
| 30      | 8        | 18.781 | 18.804   | -0.023 |
| 30      | 9        | 19.128 | 19.158   | -0.030 |
| 30      | 10       | 18.602 | 18.523   | 0.079  |
| 30      | 11       | 18.391 | 18.332   | 0.059  |
| 30      | 12       | 18.054 | 18.092   | -0.038 |
| Max     |          | 19.500 | 19.435   | 0.243  |
| Average |          | 18.763 | 18.742   | 0.021  |
| Min     |          | 18.054 | 18.092   | -0.113 |
| Std Dev |          | 0.390  | 0.400    | 0.107  |

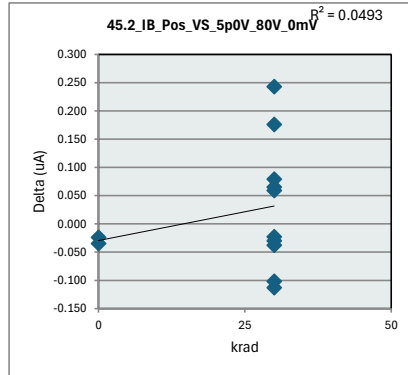

45.2\_IB\_Pos\_VS\_5p0V\_80V\_0

|             |                    |
|-------------|--------------------|
| Test Site   | J2S                |
| Tester      | FETS36401          |
| Test Number | EE213301           |
| Max Limit   | 21.7 uA            |
| Min Limit   | 12 uA              |
| krad        | 0      30          |
| LL          | 12.000      12.000 |
| Min         | 18.444      18.092 |
| Average     | 18.655      18.759 |
| Max         | 18.865      19.435 |
| UL          | 21.700      21.700 |

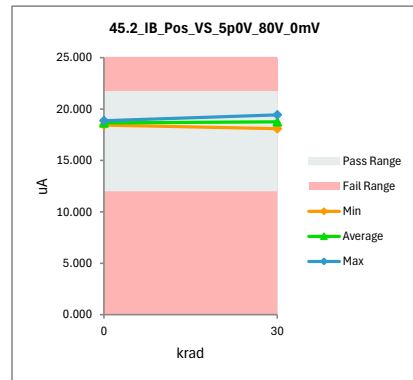

TID Report  
INA951-SEP

45.3\_IB\_Neg\_VS\_5p0V\_80V\_0mV

|             |           |           |
|-------------|-----------|-----------|
| Test Site   | J2S       | J2S       |
| Tester      | FETS36401 | FETS36417 |
| Test Number | EE213301  | EE213301  |
| Unit        | uA        | uA        |
| Max Limit   | 21.7      | 21.7      |
| Min Limit   | 12        | 12        |

| krad    | Serial # | pre    | Post.log | Delta  |
|---------|----------|--------|----------|--------|
| 0       | 1        | 18.445 | 18.446   | -0.001 |
| 0       | 2        | 18.849 | 18.850   | -0.001 |
| 30      | 3        | 18.684 | 18.755   | -0.071 |
| 30      | 4        | 19.529 | 19.422   | 0.107  |
| 30      | 5        | 18.867 | 18.607   | 0.260  |
| 30      | 6        | 18.826 | 18.524   | 0.302  |
| 30      | 7        | 19.199 | 19.282   | -0.083 |
| 30      | 8        | 18.805 | 18.790   | 0.015  |
| 30      | 9        | 19.122 | 19.145   | -0.023 |
| 30      | 10       | 18.622 | 18.525   | 0.097  |
| 30      | 11       | 18.420 | 18.308   | 0.112  |
| 30      | 12       | 18.047 | 18.057   | -0.010 |
| Max     |          | 19.529 | 19.422   | 0.302  |
| Average |          | 18.785 | 18.726   | 0.059  |
| Min     |          | 18.047 | 18.057   | -0.083 |
| Std Dev |          | 0.391  | 0.403    | 0.122  |

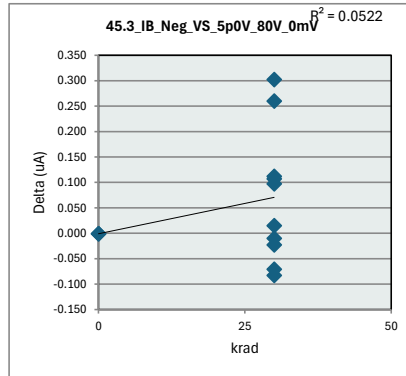

45.3\_IB\_Neg\_VS\_5p0V\_80V\_0mV

|             |               |
|-------------|---------------|
| Test Site   | J2S           |
| Tester      | FETS36401     |
| Test Number | EE213301      |
| Max Limit   | 21.7 uA       |
| Min Limit   | 12 uA         |
| krad        | 0 30          |
| LL          | 12.000 12.000 |
| Min         | 18.446 18.057 |
| Average     | 18.648 18.742 |
| Max         | 18.850 19.422 |
| UL          | 21.700 21.700 |

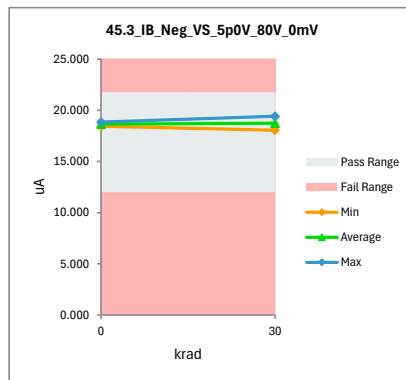



TID Report  
INA951-SEP

**51.5\_Gain\_Error\_5V\_48V**

|             |           |           |
|-------------|-----------|-----------|
| Test Site   | J2S       | J2S       |
| Tester      | FETS36401 | FETS36417 |
| Test Number | EE213301  | EE213301  |
| Unit        | m%        | m%        |
| Max Limit   | 60        | 60        |
| Min Limit   | -60       | -60       |

| krad    | Serial # | pre     | Post.log | Delta  |
|---------|----------|---------|----------|--------|
| 0       | 1        | -7.492  | -9.670   | 2.177  |
| 0       | 2        | -10.544 | -11.894  | 1.349  |
| 30      | 3        | -10.905 | -12.228  | 1.323  |
| 30      | 4        | -8.782  | -8.618   | -0.164 |
| 30      | 5        | -5.894  | -2.781   | -3.113 |
| 30      | 6        | -8.764  | -9.421   | 0.657  |
| 30      | 7        | -13.332 | -12.367  | -0.965 |
| 30      | 8        | -16.509 | -19.507  | 2.998  |
| 30      | 9        | -14.269 | -16.585  | 2.316  |
| 30      | 10       | -11.525 | -12.888  | 1.363  |
| 30      | 11       | -9.999  | -8.660   | -1.339 |
| 30      | 12       | -17.111 | -17.787  | 0.677  |
| Max     |          | -5.894  | -2.781   | 2.998  |
| Average |          | -11.260 | -11.867  | 0.607  |
| Min     |          | -17.111 | -19.507  | -3.113 |
| Std Dev |          | 3.474   | 4.586    | 1.744  |

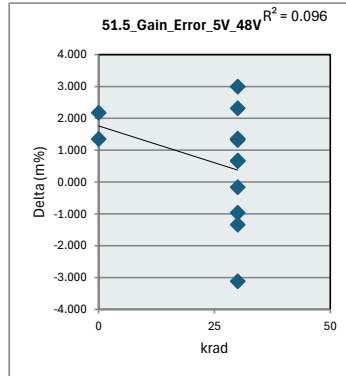

**51.5\_Gain\_Error\_5V\_48V**

|             |                 |
|-------------|-----------------|
| Test Site   | J2S             |
| Tester      | FETS36401       |
| Test Number | EE213301        |
| Max Limit   | 60 m%           |
| Min Limit   | -60 m%          |
| krad        | 0 30            |
| LL          | -60.000 -60.000 |
| Min         | -11.894 -19.507 |
| Average     | -10.782 -12.084 |
| Max         | -9.670 -2.781   |
| UL          | 60.000 60.000   |

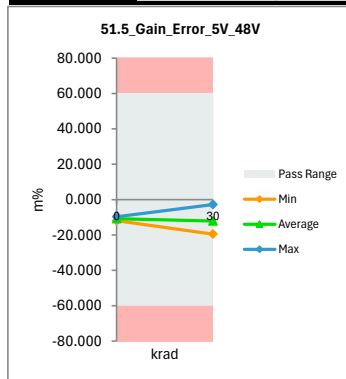

TID Report  
INA951-SEP

| 61.0_Offset_5V_48V |           |           |
|--------------------|-----------|-----------|
| Test Site          | J2S       | J2S       |
| Tester             | FETS36401 | FETS36417 |
| Test Number        | EE213301  | EE213301  |
| Unit               | uV        | uV        |
| Max Limit          | 117.27    | 117.27    |
| Min Limit          | -122.62   | -122.62   |

| krad    | Serial # | pre     | Post.log | Delta  |
|---------|----------|---------|----------|--------|
| 0       | 1        | 34.767  | 31.309   | 3.458  |
| 0       | 2        | 14.599  | 9.586    | 5.012  |
| 30      | 3        | 8.642   | -1.283   | 9.925  |
| 30      | 4        | 45.298  | 36.097   | 9.201  |
| 30      | 5        | 44.286  | 33.997   | 10.289 |
| 30      | 6        | 24.891  | 15.442   | 9.449  |
| 30      | 7        | 28.476  | 19.515   | 8.962  |
| 30      | 8        | -5.216  | -10.608  | 5.393  |
| 30      | 9        | -9.172  | -14.009  | 4.837  |
| 30      | 10       | 13.821  | 8.557    | 5.264  |
| 30      | 11       | 50.662  | 44.682   | 5.980  |
| 30      | 12       | -26.505 | -31.617  | 5.112  |
| Max     |          | 50.662  | 44.682   | 10.289 |
| Average |          | 18.712  | 11.806   | 6.907  |
| Min     |          | -26.505 | -31.617  | 3.458  |
| Std Dev |          | 23.950  | 23.076   | 2.437  |

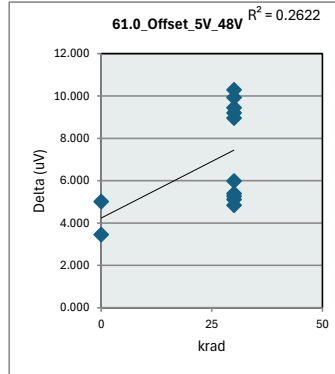

| 61.0_Offset_5V_48V |           |          |
|--------------------|-----------|----------|
| Test Site          | J2S       |          |
| Tester             | FETS36401 |          |
| Test Number        | EE213301  |          |
| Max Limit          | 117.27    | uV       |
| Min Limit          | -122.62   | uV       |
| krad               | 0         | 30       |
| LL                 | -122.620  | -122.620 |
| Min                | 9.586     | -31.617  |
| Average            | 20.448    | 10.077   |
| Max                | 31.309    | 44.682   |
| UL                 | 117.270   | 117.270  |

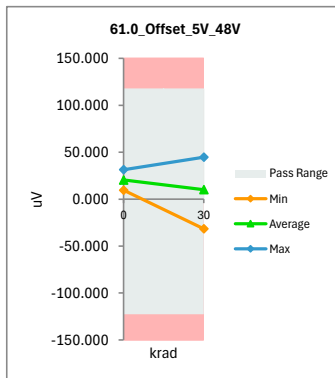

TID Report  
INA951-SEP

| 71.4_PSRR_V_V |           |           |          |        |
|---------------|-----------|-----------|----------|--------|
| Test Site     | J2S       | J2S       |          |        |
| Tester        | FETS36401 | FETS36417 |          |        |
| Test Number   | EE213301  | EE213301  |          |        |
| Unit          | uV/V      | uV/V      |          |        |
| Max Limit     | 8         | 8         |          |        |
| Min Limit     | -8        | -8        |          |        |
| krad          | Serial #  | pre       | Post.log | Delta  |
| 0             | 1         | 0.227     | 0.161    | 0.066  |
| 0             | 2         | -0.600    | -0.600   | 0.001  |
| 30            | 3         | -0.607    | -0.631   | 0.023  |
| 30            | 4         | 0.327     | 0.278    | 0.050  |
| 30            | 5         | 0.491     | 0.506    | -0.015 |
| 30            | 6         | -0.158    | -0.064   | -0.094 |
| 30            | 7         | -0.071    | -0.202   | 0.131  |
| 30            | 8         | -1.076    | -1.274   | 0.198  |
| 30            | 9         | -1.467    | -1.377   | -0.090 |
| 30            | 10        | -0.446    | -0.460   | 0.015  |
| 30            | 11        | 0.598     | 0.597    | 0.001  |
| 30            | 12        | -1.682    | -1.548   | -0.133 |
| Max           |           | 0.598     | 0.597    | 0.198  |
| Average       |           | -0.372    | -0.385   | 0.013  |
| Min           |           | -1.682    | -1.548   | -0.133 |
| Std Dev       |           | 0.750     | 0.731    | 0.094  |

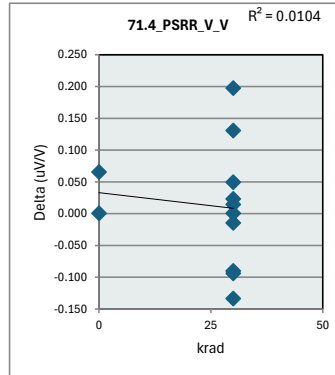

| 71.4_PSRR_V_V |           |        |
|---------------|-----------|--------|
| Test Site     | J2S       |        |
| Tester        | FETS36401 |        |
| Test Number   | EE213301  |        |
| Max Limit     | 8         | uV/V   |
| Min Limit     | -8        | uV/V   |
| krad          | 0         | 30     |
| LL            | -8.000    | -8.000 |
| Min           | -0.601    | -1.548 |
| Average       | -0.220    | -0.418 |
| Max           | 0.161     | 0.597  |
| UL            | 8.000     | 8.000  |

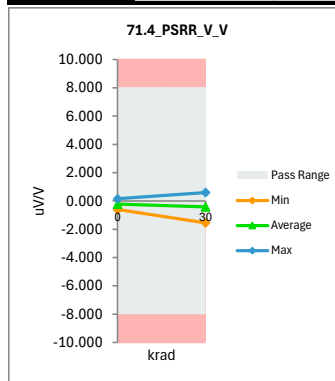

TID Report  
INA951-SEP

| 80.11_CMRR_V_80V |           |        |           |        |
|------------------|-----------|--------|-----------|--------|
| Test Site        | J2S       |        | J2S       |        |
| Tester           | FETS36401 |        | FETS36417 |        |
| Test Number      | EE213301  |        | EE213301  |        |
| Unit             | nV/V      |        | nV/V      |        |
| Max Limit        | 99        |        | 99        |        |
| Min Limit        | -99       |        | -99       |        |
| krad             | Serial #  | pre    | Post.log  | Delta  |
| 0                | 1         | 11.735 | 10.087    | 1.649  |
| 0                | 2         | 14.965 | 2.995     | 11.971 |
| 30               | 3         | 7.404  | 16.233    | -8.830 |
| 30               | 4         | 5.907  | -2.916    | 8.823  |
| 30               | 5         | 7.325  | 7.249     | 0.075  |
| 30               | 6         | 18.430 | 8.511     | 9.920  |
| 30               | 7         | 11.342 | 10.087    | 1.255  |
| 30               | 8         | 21.819 | 16.077    | 5.742  |
| 30               | 9         | 17.407 | 1.419     | 15.989 |
| 30               | 10        | 18.510 | 3.546     | 14.964 |
| 30               | 11        | 18.982 | 1.655     | 17.327 |
| 30               | 12        | 18.589 | 2.995     | 15.595 |
| Max              |           | 21.819 | 16.233    | 17.327 |
| Average          |           | 14.368 | 6.495     | 7.873  |
| Min              |           | 5.907  | -2.916    | -8.830 |
| Std Dev          |           | 5.424  | 5.939     | 8.056  |

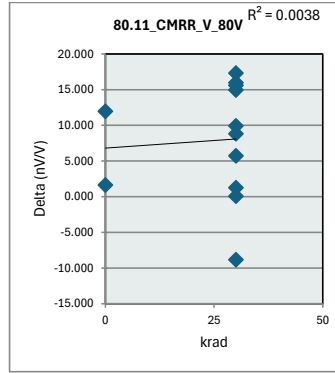

| 80.11_CMRR_V_80V |           |         |
|------------------|-----------|---------|
| Test Site        | J2S       |         |
| Tester           | FETS36401 |         |
| Test Number      | EE213301  |         |
| Max Limit        | 99        | nV/V    |
| Min Limit        | -99       | nV/V    |
| krad             | 0         | 30      |
| LL               | -99.000   | -99.000 |
| Min              | 2.995     | -2.916  |
| Average          | 6.541     | 6.486   |
| Max              | 10.087    | 16.233  |
| UL               | 99.000    | 99.000  |

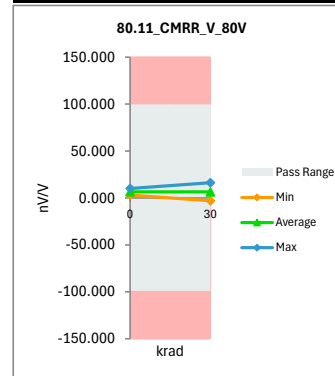

TID Report  
INA951-SEP

| 90.0_Swing_Low_5V_48V_n1 |           |           |
|--------------------------|-----------|-----------|
| Test Site                | J2S       | J2S       |
| Tester                   | FETS36401 | FETS36417 |
| Test Number              | EE213301  | EE213301  |
| Unit                     | mV        | mV        |
| Max Limit                | 20        | 20        |
| Min Limit                | 0         | 0         |

| krad    | Serial # | pre   | Post.log | Delta  |
|---------|----------|-------|----------|--------|
| 0       | 1        | 3.556 | 3.561    | -0.005 |
| 0       | 2        | 3.446 | 3.444    | 0.002  |
| 30      | 3        | 3.782 | 4.127    | -0.345 |
| 30      | 4        | 3.804 | 4.084    | -0.280 |
| 30      | 5        | 3.772 | 4.137    | -0.365 |
| 30      | 6        | 3.637 | 4.161    | -0.524 |
| 30      | 7        | 3.918 | 4.358    | -0.440 |
| 30      | 8        | 3.867 | 3.868    | -0.001 |
| 30      | 9        | 3.848 | 3.871    | -0.023 |
| 30      | 10       | 4.073 | 4.056    | 0.017  |
| 30      | 11       | 3.742 | 3.759    | -0.017 |
| 30      | 12       | 3.748 | 3.747    | 0.001  |
| Max     |          | 4.073 | 4.358    | 0.017  |
| Average |          | 3.766 | 3.931    | -0.165 |
| Min     |          | 3.446 | 3.444    | -0.524 |
| Std Dev |          | 0.165 | 0.270    | 0.207  |

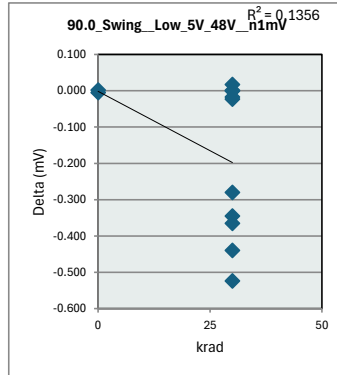

| 90.0_Swing_Low_5V_48V_n1 |           |        |
|--------------------------|-----------|--------|
| Test Site                | J2S       |        |
| Tester                   | FETS36401 |        |
| Test Number              | EE213301  |        |
| Max Limit                | 20        | mV     |
| Min Limit                | 0         | mV     |
| krad                     | 0         | 30     |
| LL                       | 0.000     | 0.000  |
| Min                      | 3.444     | 3.747  |
| Average                  | 3.503     | 4.017  |
| Max                      | 3.561     | 4.358  |
| UL                       | 20.000    | 20.000 |

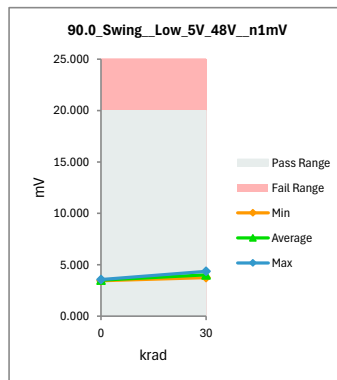

TID Report  
INA951-SEP

100.0\_Swing\_Rest\_5V\_48V\_0

|             |           |           |
|-------------|-----------|-----------|
| Test Site   | J2S       | J2S       |
| Tester      | FETS36401 | FETS36417 |
| Test Number | EE213301  | EE213301  |
| Unit        | mV        | mV        |
| Max Limit   | 20        | 20        |
| Min Limit   | 0         | 0         |

| krad    | Serial # | pre   | Post.log | Delta  |
|---------|----------|-------|----------|--------|
| 0       | 1        | 3.608 | 3.596    | 0.012  |
| 0       | 2        | 3.498 | 3.481    | 0.017  |
| 30      | 3        | 3.835 | 4.125    | -0.290 |
| 30      | 4        | 3.854 | 4.073    | -0.219 |
| 30      | 5        | 3.831 | 4.135    | -0.304 |
| 30      | 6        | 3.688 | 4.136    | -0.448 |
| 30      | 7        | 3.975 | 4.344    | -0.369 |
| 30      | 8        | 3.922 | 3.909    | 0.013  |
| 30      | 9        | 3.897 | 3.907    | -0.010 |
| 30      | 10       | 4.126 | 4.096    | 0.030  |
| 30      | 11       | 3.801 | 3.799    | 0.002  |
| 30      | 12       | 3.810 | 3.788    | 0.022  |
| Max     |          | 4.126 | 4.344    | 0.030  |
| Average |          | 3.820 | 3.949    | -0.129 |
| Min     |          | 3.498 | 3.481    | -0.448 |
| Std Dev |          | 0.166 | 0.250    | 0.182  |

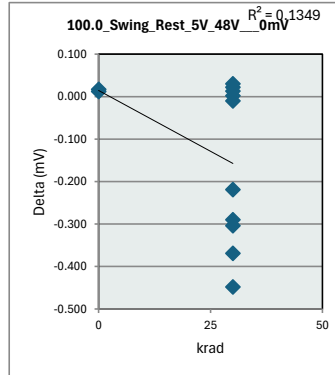

100.0\_Swing\_Rest\_5V\_48V

|             |               |
|-------------|---------------|
| Test Site   | J2S           |
| Tester      | FETS36401     |
| Test Number | EE213301      |
| Max Limit   | 20 mV         |
| Min Limit   | 0 mV          |
| krad        | 0 30          |
| LL          | 0.000 0.000   |
| Min         | 3.481 3.788   |
| Average     | 3.539 4.031   |
| Max         | 3.596 4.344   |
| UL          | 20.000 20.000 |

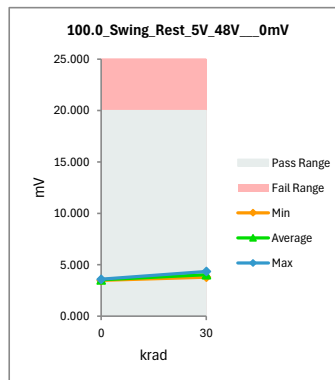

TID Report  
INA951-SEP

110.0\_Swing\_High\_5V\_48V\_250

|             |           |           |
|-------------|-----------|-----------|
| Test Site   | J2S       | J2S       |
| Tester      | FETS36401 | FETS36417 |
| Test Number | EE213301  | EE213301  |
| Unit        | mV        | mV        |
| Max Limit   | 150       | 150       |
| Min Limit   | 15        | 15        |

| krad    | Serial # | pre    | Post.log | Delta   |
|---------|----------|--------|----------|---------|
| 0       | 1        | 70.491 | 70.376   | 0.115   |
| 0       | 2        | 69.658 | 69.597   | 0.061   |
| 30      | 3        | 69.945 | 79.191   | -9.246  |
| 30      | 4        | 69.471 | 79.031   | -9.560  |
| 30      | 5        | 69.517 | 78.539   | -9.022  |
| 30      | 6        | 69.763 | 80.772   | -11.009 |
| 30      | 7        | 69.454 | 78.979   | -9.525  |
| 30      | 8        | 68.593 | 70.224   | -1.631  |
| 30      | 9        | 69.071 | 70.859   | -1.788  |
| 30      | 10       | 69.726 | 71.332   | -1.606  |
| 30      | 11       | 69.199 | 70.950   | -1.751  |
| 30      | 12       | 70.154 | 72.053   | -1.899  |
| Max     |          | 70.491 | 80.772   | 0.115   |
| Average |          | 69.587 | 74.325   | -4.738  |
| Min     |          | 68.593 | 69.597   | -11.009 |
| Std Dev |          | 0.501  | 4.463    | 4.430   |

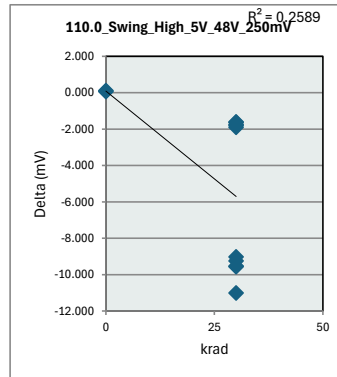

110.0\_Swing\_High\_5V\_48V\_2

|             |           |           |
|-------------|-----------|-----------|
| Test Site   | J2S       | J2S       |
| Tester      | FETS36401 | FETS36417 |
| Test Number | EE213301  | EE213301  |
| Max Limit   | 150       | mV        |
| Min Limit   | 15        | mV        |
| krad        | 0         | 30        |
| LL          | 15.000    | 15.000    |
| Min         | 69.597    | 70.224    |
| Average     | 69.987    | 75.193    |
| Max         | 70.376    | 80.772    |
| UL          | 150.000   | 150.000   |

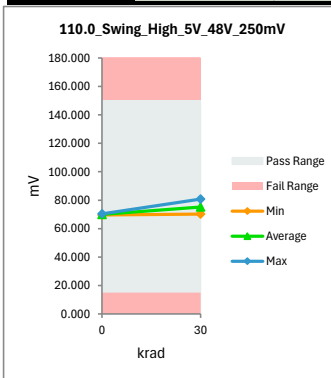

TID Report  
INA951-SEP

120.0\_Swing\_High\_2p7V\_48V\_1

|             |           |           |
|-------------|-----------|-----------|
| Test Site   | J2S       | J2S       |
| Tester      | FETS36401 | FETS36417 |
| Test Number | EE213301  | EE213301  |
| Unit        | mV        | mV        |
| Max Limit   | 100       | 100       |
| Min Limit   | 15        | 15        |

| krad    | Serial # | pre    | Post.log | Delta  |
|---------|----------|--------|----------|--------|
| 0       | 1        | 39.017 | 38.874   | 0.143  |
| 0       | 2        | 38.290 | 38.138   | 0.152  |
| 30      | 3        | 38.289 | 45.592   | -7.303 |
| 30      | 4        | 37.819 | 45.143   | -7.324 |
| 30      | 5        | 37.864 | 45.280   | -7.416 |
| 30      | 6        | 38.591 | 47.576   | -8.985 |
| 30      | 7        | 37.776 | 45.300   | -7.524 |
| 30      | 8        | 37.686 | 38.868   | -1.182 |
| 30      | 9        | 37.872 | 39.066   | -1.194 |
| 30      | 10       | 38.241 | 39.419   | -1.178 |
| 30      | 11       | 38.163 | 39.464   | -1.301 |
| 30      | 12       | 38.549 | 39.783   | -1.234 |
| Max     |          | 39.017 | 47.576   | 0.152  |
| Average |          | 38.180 | 41.875   | -3.696 |
| Min     |          | 37.686 | 38.138   | -8.985 |
| Std Dev |          | 0.401  | 3.522    | 3.604  |

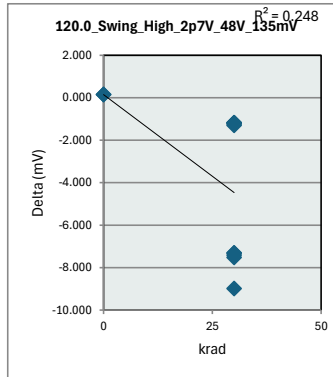

120.0\_Swing\_High\_2p7V\_48V

|             |                 |
|-------------|-----------------|
| Test Site   | J2S             |
| Tester      | FETS36401       |
| Test Number | EE213301        |
| Max Limit   | 100 mV          |
| Min Limit   | 15 mV           |
| krad        | 0 30            |
| LL          | 15.000 15.000   |
| Min         | 38.138 38.868   |
| Average     | 38.506 42.549   |
| Max         | 38.874 47.576   |
| UL          | 100.000 100.000 |

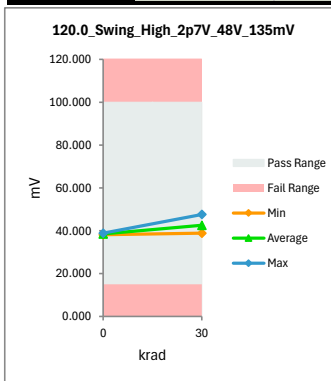

TID Report  
INA951-SEP

130.0\_Swing\_High\_10V\_48V\_1V

|             |           |           |
|-------------|-----------|-----------|
| Test Site   | J2S       | J2S       |
| Tester      | FETS36401 | FETS36417 |
| Test Number | EE213301  | EE213301  |
| Unit        | mV        | mV        |
| Max Limit   | 500       | 500       |
| Min Limit   | 100       | 100       |

| krad    | Serial # | pre     | Post.log | Delta   |
|---------|----------|---------|----------|---------|
| 0       | 1        | 129.756 | 129.585  | 0.171   |
| 0       | 2        | 128.510 | 128.347  | 0.163   |
| 30      | 3        | 128.321 | 143.192  | -14.871 |
| 30      | 4        | 128.098 | 143.353  | -15.255 |
| 30      | 5        | 127.674 | 142.565  | -14.891 |
| 30      | 6        | 129.287 | 147.200  | -17.913 |
| 30      | 7        | 127.674 | 142.944  | -15.270 |
| 30      | 8        | 127.055 | 130.229  | -3.174  |
| 30      | 9        | 127.924 | 131.245  | -3.321  |
| 30      | 10       | 128.612 | 131.822  | -3.210  |
| 30      | 11       | 127.691 | 131.116  | -3.425  |
| 30      | 12       | 129.414 | 133.028  | -3.614  |
| Max     |          | 129.756 | 147.200  | 0.171   |
| Average |          | 128.335 | 136.219  | -7.884  |
| Min     |          | 127.055 | 128.347  | -17.913 |
| Std Dev |          | 0.817   | 6.927    | 7.006   |

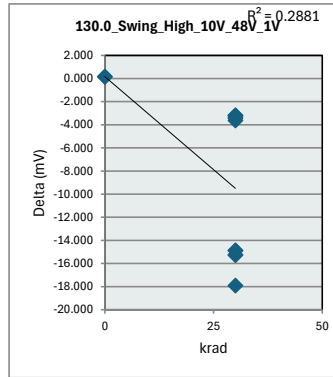

130.0\_Swing\_High\_10V\_48V

|             |                 |
|-------------|-----------------|
| Test Site   | J2S             |
| Tester      | FETS36401       |
| Test Number | EE213301        |
| Max Limit   | 500 mV          |
| Min Limit   | 100 mV          |
| krad        | 0 30            |
| LL          | 100.000 100.000 |
| Min         | 128.347 130.229 |
| Average     | 128.966 137.669 |
| Max         | 129.585 147.200 |
| UL          | 500.000 500.000 |

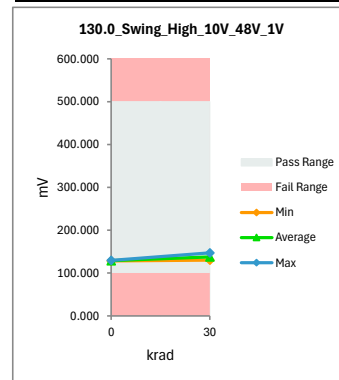

## Important Limitations on Use of Data Exceeding Specified Limits

TI is providing this data for your convenience. However, we want to make clear the significant limitations of its usefulness as an indicator of how devices may perform in various applications.

THIS DATA IS PROVIDED "AS IS" WITHOUT ANY EXPRESS OR IMPLIED WARRANTY OF ANY KIND INCLUDING WARRANTIES OF MERCHANTABILITY, NONINFRINGEMENT OF INTELLECTUAL PROPERTY, OR FITNESS FOR ANY PARTICULAR PURPOSE. IN NO EVENT SHALL TI OR ITS SUPPLIERS BE LIABLE FOR ANY DAMAGES WHATSOEVER (INCLUDING, WITHOUT LIMITATION, DAMAGES FOR LOSS OF PROFITS, BUSINESS INTERRUPTION, LOSS OF INFORMATION) ARISING OUT OF THE USE OF OR INABILITY TO USE THE INFORMATION, EVEN IF TI HAS BEEN ADVISED OF THE POSSIBILITY OF SUCH DAMAGES.

Your use of this data, and all consequences of such use, is solely your responsibility. You must perform sufficient engineering and additional qualification testing in order to properly evaluate your application and determine whether a candidate device is suitable for use in that application.

TI semiconductor components are specifically designed and manufactured to be used within the electrical, thermal, mechanical and other parameters set forth in TI's product datasheets. Quality and reliability data provided by Texas Instruments, such as MTBF and fit rate data, is intended to be an estimate of product performance based upon history only. It does not imply that any performance levels reflected in such data can be met if the product is operated outside the conditions expressly stated in the latest published datasheet for a device.

Plastic encapsulated TI semiconductor devices are neither designed nor warranted as suitable for use in military applications and/or military environments.

THIS INFORMATION SHOULD NOT BE USED TO ASSIST IN THE PRACTICE OF "UPRATING" OR "UPSCREENING" DEVICES FOR USE IN MILITARY OR OTHER CRITICAL APPLICATIONS. There are significant limitations of this information as an indicator of how commercial, off-the-shelf (COTS) devices may perform in such applications or environments, and about the hazards of using COTS devices in such applications. TI strongly believes that semiconductor components should never be used outside their specified tolerance levels as up-screening can lead directly to system or component failure. Such failures may present distinct risks to end-users and to third parties. TI cannot accept any responsibility for component or system failures that occur due to the misuse of its products, including misuse that may result from the practice of up-screening.

Any use of TI components beyond their rated limits voids all warranty responsibility of TI with respect to such devices, and also voids all responsibility of TI with respect to any applications assistance, product design, software performance or services of any kind that were or may have been performed in connection with the sale of any such devices. Further, resale of TI's products or services with statements different from or beyond the parameters stated by TI for that product or service in official TI data books or datasheets, or without the warnings or instructions provided by TI, voids all express and any implied warranties for the associated TI product or service, and is an unfair and deceptive business practice.

## IMPORTANT NOTICE AND DISCLAIMER

TI PROVIDES TECHNICAL AND RELIABILITY DATA (INCLUDING DATASHEETS), DESIGN RESOURCES (INCLUDING REFERENCE DESIGNS), APPLICATION OR OTHER DESIGN ADVICE, WEB TOOLS, SAFETY INFORMATION, AND OTHER RESOURCES "AS IS" AND WITH ALL FAULTS, AND DISCLAIMS ALL WARRANTIES, EXPRESS AND IMPLIED, INCLUDING WITHOUT LIMITATION ANY IMPLIED WARRANTIES OF MERCHANTABILITY, FITNESS FOR A PARTICULAR PURPOSE OR NON-INFRINGEMENT OF THIRD PARTY INTELLECTUAL PROPERTY RIGHTS.

These resources are intended for skilled developers designing with TI products. You are solely responsible for (1) selecting the appropriate TI products for your application, (2) designing, validating and testing your application, and (3) ensuring your application meets applicable standards, and any other safety, security, regulatory or other requirements.

These resources are subject to change without notice. TI grants you permission to use these resources only for development of an application that uses the TI products described in the resource. Other reproduction and display of these resources is prohibited. No license is granted to any other TI intellectual property right or to any third party intellectual property right. TI disclaims responsibility for, and you fully indemnify TI and its representatives against any claims, damages, costs, losses, and liabilities arising out of your use of these resources.

TI's products are provided subject to [TI's Terms of Sale](#), [TI's General Quality Guidelines](#), or other applicable terms available either on [ti.com](#) or provided in conjunction with such TI products. TI's provision of these resources does not expand or otherwise alter TI's applicable warranties or warranty disclaimers for TI products. Unless TI explicitly designates a product as custom or customer-specified, TI products are standard, catalog, general purpose devices.

TI objects to and rejects any additional or different terms you may propose.

## IMPORTANT NOTICE AND DISCLAIMER

TI PROVIDES TECHNICAL AND RELIABILITY DATA (INCLUDING DATASHEETS), DESIGN RESOURCES (INCLUDING REFERENCE DESIGNS), APPLICATION OR OTHER DESIGN ADVICE, WEB TOOLS, SAFETY INFORMATION, AND OTHER RESOURCES "AS IS" AND WITH ALL FAULTS, AND DISCLAIMS ALL WARRANTIES, EXPRESS AND IMPLIED, INCLUDING WITHOUT LIMITATION ANY IMPLIED WARRANTIES OF MERCHANTABILITY, FITNESS FOR A PARTICULAR PURPOSE OR NON-INFRINGEMENT OF THIRD PARTY INTELLECTUAL PROPERTY RIGHTS.

These resources are intended for skilled developers designing with TI products. You are solely responsible for (1) selecting the appropriate TI products for your application, (2) designing, validating and testing your application, and (3) ensuring your application meets applicable standards, and any other safety, security, regulatory or other requirements.

These resources are subject to change without notice. TI grants you permission to use these resources only for development of an application that uses the TI products described in the resource. Other reproduction and display of these resources is prohibited. No license is granted to any other TI intellectual property right or to any third party intellectual property right. TI disclaims responsibility for, and you fully indemnify TI and its representatives against any claims, damages, costs, losses, and liabilities arising out of your use of these resources.

TI's products are provided subject to [TI's Terms of Sale](#), [TI's General Quality Guidelines](#), or other applicable terms available either on [ti.com](http://ti.com) or provided in conjunction with such TI products. TI's provision of these resources does not expand or otherwise alter TI's applicable warranties or warranty disclaimers for TI products. Unless TI explicitly designates a product as custom or customer-specified, TI products are standard, catalog, general purpose devices.

TI objects to and rejects any additional or different terms you may propose.

Copyright © 2026, Texas Instruments Incorporated

Last updated 10/2025