

SN54SC1G125-SEP Single-Event Effects (SEE) Radiation Report



ABSTRACT

The purpose of this study is to characterize the single-event effects (SEE) performance due to heavy-ion irradiation of the SN54SC1G125-SEP. SEE performance was verified at minimum (1.1V) and maximum (5.5V) operating conditions. Heavy-ions with an LET_{EFF} of 47MeV-cm²/mg were used to irradiate three production devices with a fluence of 1 × 10⁷ ions/cm². The results demonstrate that the SN54SC1G125-SEP is SEL-free up to LET_{EFF} = 47MeV-cm²/mg as 125°C. Single-event transient (SET) performance at minimum and maximum operating voltages saw no excursions ≥|2%| trigger up to fluence of 1 × 10⁷ ions/cm², as shown and discussed in this report.

Table of Contents

1 Overview	2
2 Single-Event Effects (SEE)	2
3 Test Device and Test Board Information	3
4 Irradiation Facility and Setup	5
5 Results	7
5.1 Single-Event Latch-up (SEL) Results.....	7
5.2 Single-Event Transients (SET) Results.....	9
6 Event Rate Calculations	10
7 Summary	11
8 References	11

Trademarks

National Instruments™ is a trademark of National Instruments.
All trademarks are the property of their respective owners.

1 Overview

The SN54SC1G125-SEP is a single line driver with a 3-state output. The output is disabled when the output-enable (\overline{OE}) input pin is at a logic high level. When (\overline{OE}) is at a logic low level, true data is passed from the A input to the Y output.

For more information, see the SN54SC1G125-SEP [product page](#).

Table 1-1. Overview Information

Description ⁽¹⁾	Device Information
TI Part Number	SN54SC1G125-SEP
Orderable Part Number	54SC1G125MDBVTSEP
VID Number	V62/26602-01XE
Device Function	Radiation-tolerant, Single 2-Input Positive-AND Gate
Technology	LBC9
Exposure Facility (SET)	Facility for Rare Isotope Beams (FRIB) at Michigan State University – FRIB Single Event Effects (FSEE) Facility
Exposure Facility (SEL)	K500 Cyclotron at Michigan State University
Heavy Ion Fluence per Run	1×10^7 ions/cm ²
Irradiation Temperature	25°C (for SET testing) and 125°C (for SEL testing)

- (1) TI may provide technical, applications or design advice, quality characterization, and reliability data or service, providing these items shall not expand or otherwise affect TI's warranties as set forth in the Texas Instruments Incorporated Standard Terms and Conditions of Sale for Semiconductor Products and no obligation or liability shall arise from Semiconductor Products and no obligation or liability shall arise from TI's provision of such items.

2 Single-Event Effects (SEE)

The primary single-event effect (SEE) event of interest in the SN54SC1G125-SEP is the destructive single-event latch-up (SEL). From a risk or impact perspective, the occurrence of an SEL is potentially the most destructive SEE event and the biggest concern for space applications. In mixed technologies such as the Linear BiCMOS (LBC9) process used for SN54SC1G125-SEP, the CMOS circuitry introduces a potential SEL susceptibility. SEL can occur if excess current injection caused by the passage of an energetic ion is high enough to trigger the formation of a parasitic cross-coupled PNP and NPN bipolar structure (formed between the p-substrate and n-well and n+ and p+ contacts). The parasitic bipolar structure initiated by a single event creates a high-conductance path (inducing a steady-state current that is typically orders of magnitude higher than the normal operating current) between power and ground that persists (is latched) until power is removed or until the device is destroyed by the high-current state. The process modifications applied for SEL-mitigation were sufficient, as the SN54SC1G125-SEP exhibited no SEL with heavy-ions up to an LET_{EFF} of 47MeV-cm²/mg at a fluence of 1×10^7 ions/cm² and a chip temperature of 125°C.

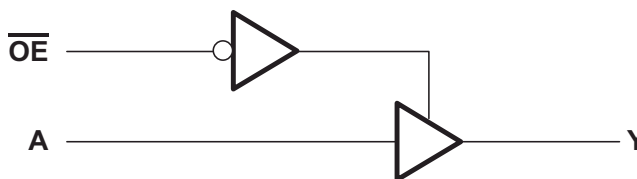

Figure 2-1. Functional Block Diagram of the SN54SC1G125-SEP

3 Test Device and Test Board Information

The SN54SC1G125-SEP is a packaged 5-pin, SOT-23 plastic package shown in the pinout diagram in [Figure 3-1](#). [Figure 3-2](#) shows the device with the package cap decapped to reveal the die for heavy-ion testing. [Figure 3-3](#) shows the evaluation board used for radiation testing. [Figure 3-4](#) shows the bias diagram used for SEL testing. [Figure 3-5](#) and [Figure 3-6](#) show the bias diagrams used for SET testing.

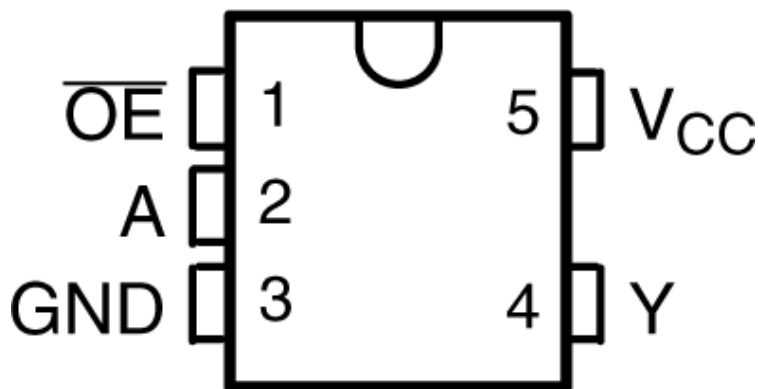

Figure 3-1. SN54SC1G125-SEP Pinout Diagram



Figure 3-2. Photo of SN54SC1G125-SEP Package Decapped

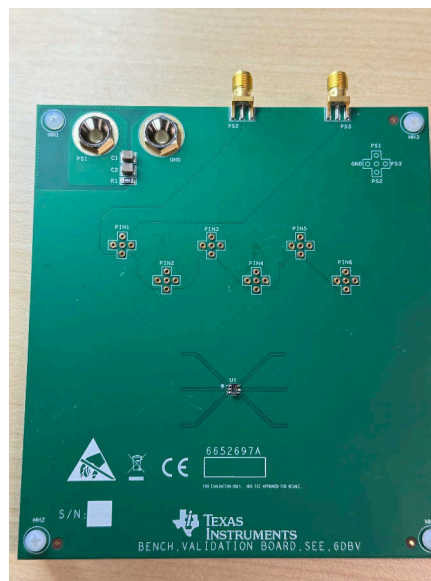

Figure 3-3. SN54SC1G125-SEP Evaluation Board (Top View)

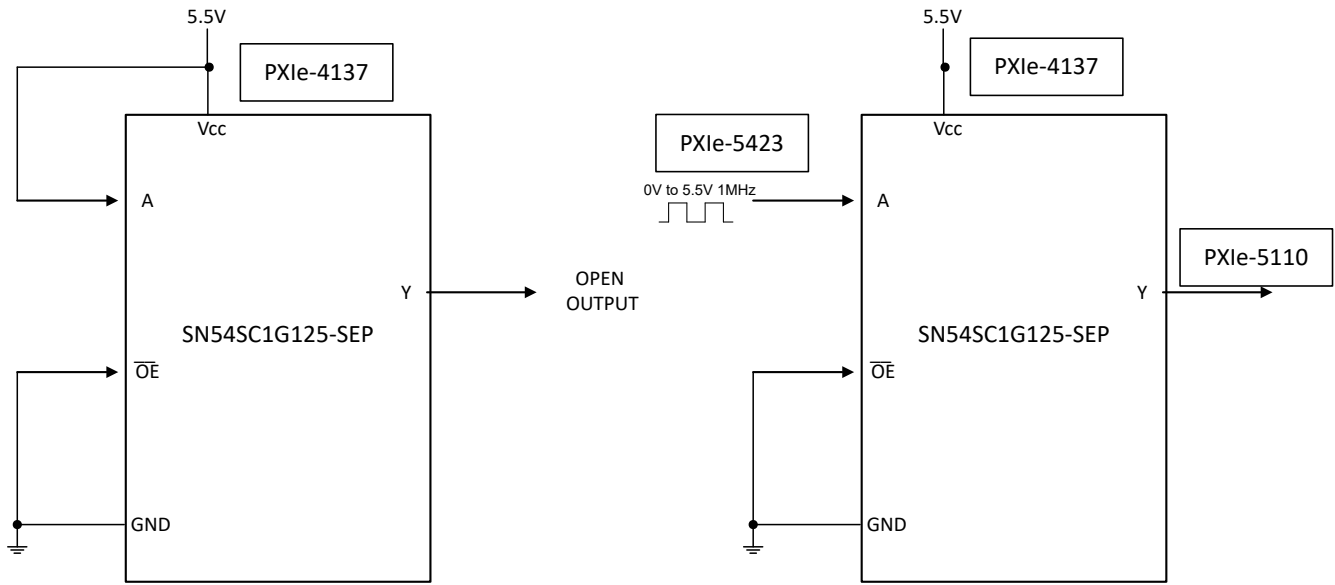

Figure 3-4. SN54SC1G125-SEP SEL Bias Diagram Figure 3-5. SN54SC1G125-SEP SET Bias 1 Diagram

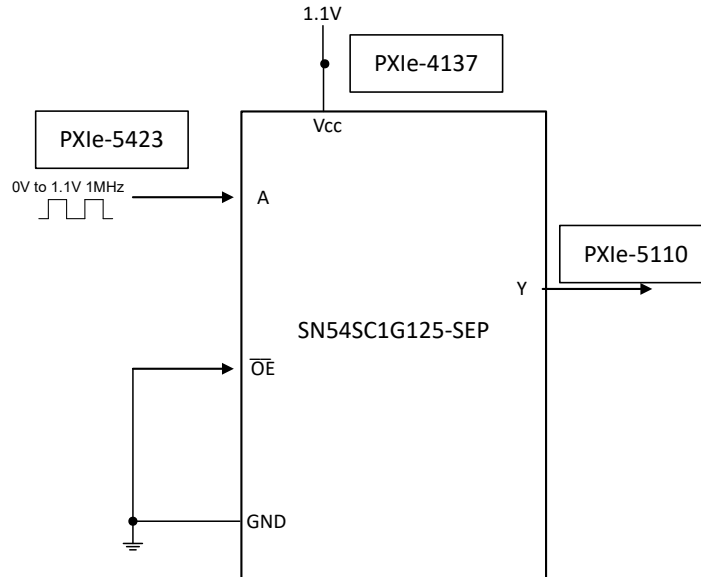

Figure 3-6. SN54SC1G125-SEP SET Bias 2 Diagram

4 Irradiation Facility and Setup

The heavy-ion species used for the SEL studies on this product were provided and delivered by the MSU Cyclotron Radiation Effects Facility using a superconducting cyclotron and an advanced electron cyclotron resonance (ECR) ion source. At the fluxes used, ion beams had good flux stability and high irradiation uniformity over a 1in diameter circular cross-sectional area for the in-air station. Uniformity is achieved by magnetic defocusing. The flux of the beam is regulated over a broad range spanning several orders of magnitude. For this study, ion flux of 1×10^5 ions/cm²-s were used to provide heavy-ion fluences of approximately 1×10^7 ions/cm² for SEL testing. For the experiments conducted on this report, ¹⁰⁹Ag ions at angle of incidence of 0° for an LET_{EFF} of 47 MeV × cm²/mg were used. The total kinetic energy of ¹⁰⁹Ag in the vacuum is 2.125GeV (19.5 MeV/nucleon). Ion uniformity for these experiments was 91.54%.

Figure 4-1 shows one of the three SN54SC1G125-SEP test boards used for experiments at the MSU facility. The in-air gap between the device and the ion beam port window was maintained at 50mm for all runs.

The heavy-ion species used for the SET studies on this product were provided and delivered by the Facility for Rare Isotope Beams (FRIB) at Michigan State University (FRIB Single Event Effects (FSEE) Facility's linear accelerator.) The FSEE Facility has a dedicated beamline built on the FRIB linac infrastructure with a user experimental station at the end of the FSEE beamline. Ion beams are delivered with high uniformity over a 1-inch diameter exposure area using a thin vacuum window. For this study, ion flux of 1×10^5 ions/cm²-s was used to provide heavy ion fluence of 1×10^7 ions/cm² using ¹²⁹Xe ion at a linac energy of 25 MeV/μ. Ion beam uniformity for all tests was 96.42%.

Figure 4-2 shows one of the three SN54SC1G125-SEP test boards used for experiments at the MSU facility. The in-air gap between the device and the ion beam port window was maintained at 70mm for all runs.

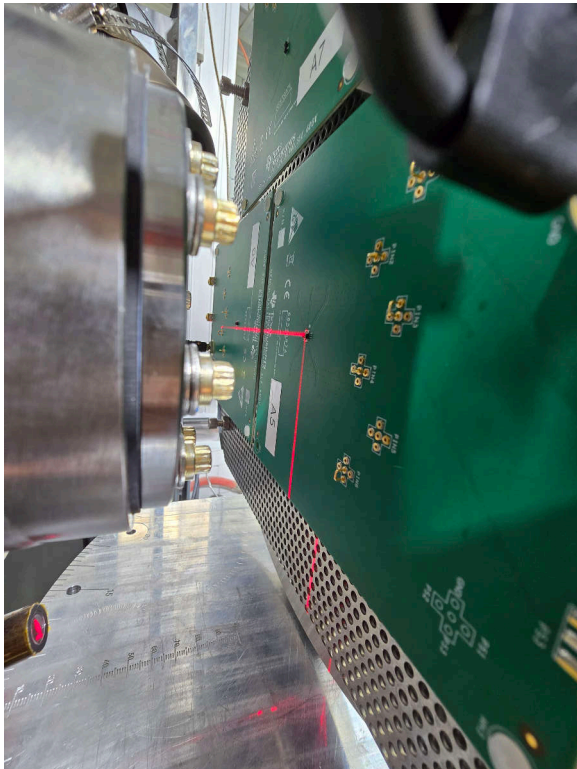

Figure 4-1. SN54SC1G125-SEP Evaluation Board at the MSU Facility (SEL)



Figure 4-2. SN54SC1G125-SEP Evaluation Board at the MSU Facility (SET)



Figure 4-3. SN54SC1G125-SEP Thermal Image for SEL

5 Results

5.1 Single-Event Latch-up (SEL) Results

During SEL characterization, the device was heated using forced hot air, maintaining device temperature at 125°C. A FLIR (FLIR ONE Pro LT) thermal camera was used to validate die temperature to make sure the device was accurately heated (see Figure 4-3.) The species used for SEL testing was a Silver (¹⁰⁹Ag) ion at 19.5MeV/μ with an angle-of-incidence of 0° for an LET_{EFF} of 47MeV-cm²/mg. A fluence of approximately 1 × 10⁷ ions/cm² was used for each run.

The three devices were powered up and exposed to the heavy-ions using the maximum recommended supply voltage of 5.5V using a National Instruments™ PXI Chassis PXIe-4137 on VCC and input A. The run duration to achieve this fluence was approximately 100 seconds. As listed in Table 5-1, no SEL events were observed during the 10 runs, indicating that the SN54SC1G125-SEP is SEL-free. Figure 5-1, Figure 5-2, and Figure 5-3 show the plots of current versus time for runs one, six, and seven, respectively.

Table 5-1. Summary of SN54SC1G125-SEP SEL Test Conditions and Results

Run Number	Unit Number	Distance (mm)	Temperature (°C)	Ion	Angle	Flux (ions × cm ² /mg)	Fluence (Number of ions)	LET _{EFF} (MeV × cm ² /mg)	Did an SEL Event Occur?
1	1	50	125	Ag	0°	1.00E+05	1.00E+07	47	No
2	1	50	125	Ag	0°	1.00E+05	1.00E+07	47	No
3	1	50	125	Ag	0°	1.00E+05	1.00E+07	47	No
4	2	50	125	Ag	0°	1.00E+05	1.00E+07	47	No
5	2	50	125	Ag	0°	1.00E+05	1.00E+07	47	No
6	2	50	125	Ag	0°	1.00E+05	1.00E+07	47	No
7	3	50	125	Ag	0°	1.00E+05	1.00E+07	47	No
8	3	50	125	Ag	0°	1.00E+05	1.00E+07	47	No
9	3	50	125	Ag	0°	1.00E+05	1.00E+07	47	No
10	3	50	125	Ag	0°	1.00E+05	1.50E+07	47	No

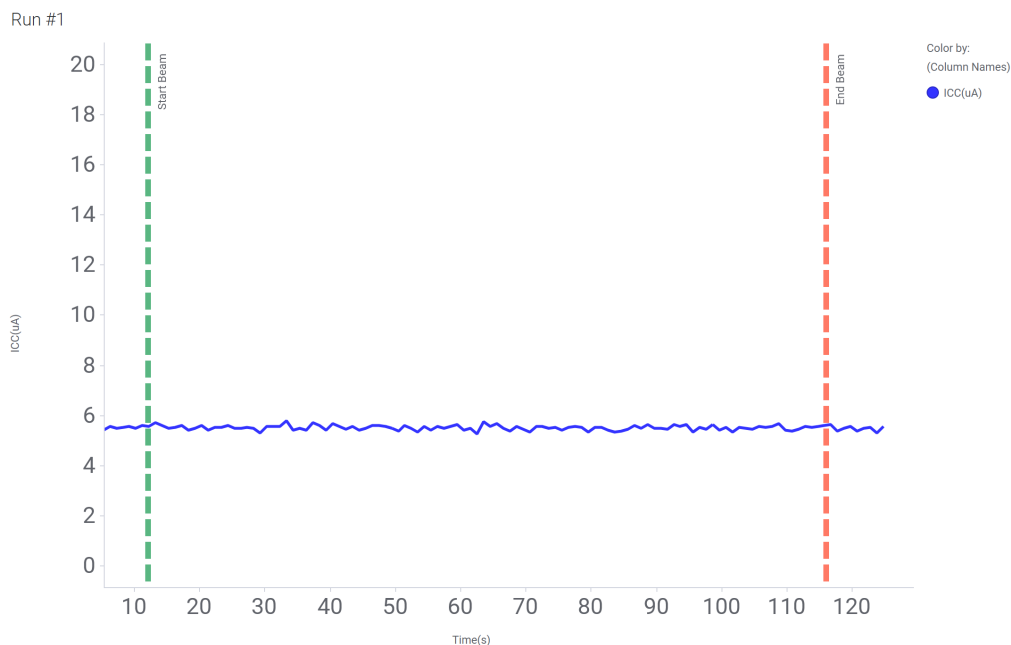

Figure 5-1. Current versus Time for Run 1 of the SN54SC1G125-SEP at T = 125°C

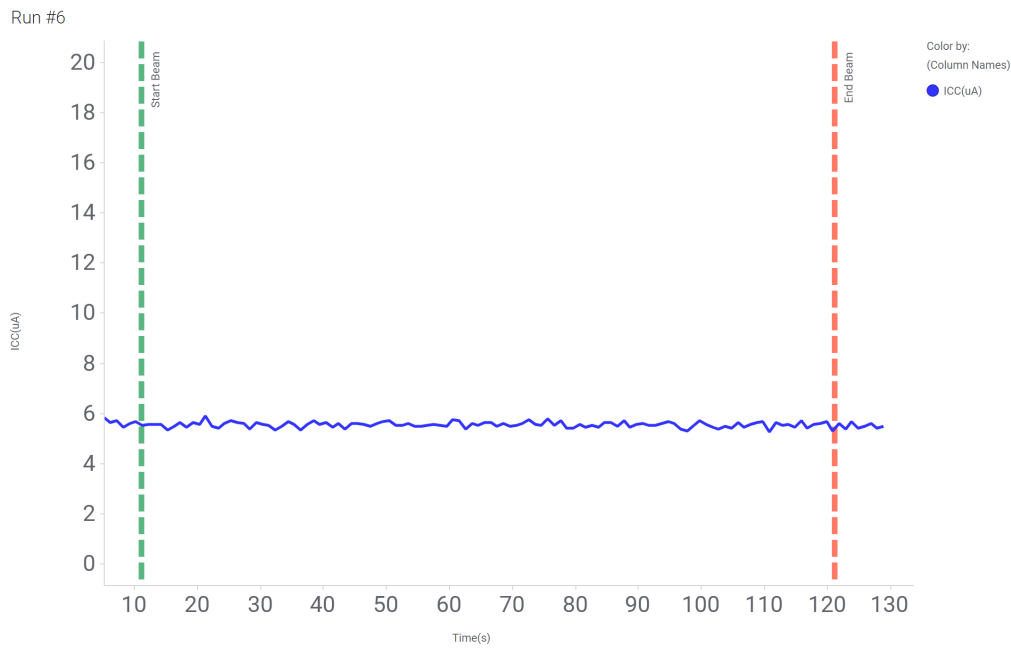

Figure 5-2. Current versus Time for Run 6 of the SN54SC1G125-SEP at T = 125°C

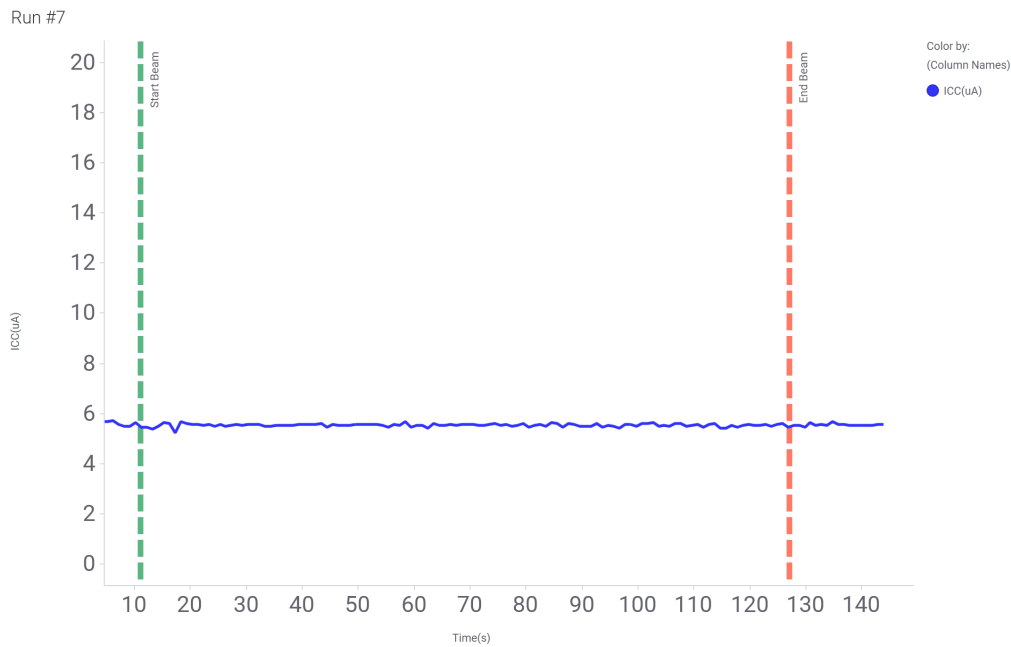

Figure 5-3. Current versus Time for Run 7 of the SN54SC1G125-SEP at T = 125°C

No SEL events were observed, indicating that the SN54SC1G125-SEP is SEL-immune at $LET_{EFF} = 47 \text{ MeV} \cdot \text{cm}^2/\text{mg}$ and $T = 125^\circ\text{C}$. Using the MFTF method shown in [Single-Event Effects \(SEE\) Confidence Internal Calculations](#), the upper-bound cross section (using a 95% confidence level) is calculated as:

$$\sigma_{SEL} \leq 3.69 \times 10^{-8} \text{ cm}^2/\text{device for } LET_{EFF} = 47 \text{ MeV} \cdot \text{cm}^2/\text{mg and } T = 125^\circ\text{C} \quad (1)$$

5.2 Single-Event Transients (SET) Results

SETs are defined as heavy-ion-induced transient upsets on output pins Y of the SN54SC1G125-SEP. SET testing was performed at room temperature (no external temperature control applied). The species used for the SET testing was ^{129}Xe for a $\text{LET}_{\text{EFF}} = 47\text{MeV} \times \text{cm}^2/\text{mg}$. Flux of approximately 10^5 ions/cm² × s and a fluence of approximately 10^7 ions/cm² were used for the SET runs.

One unit was tested across multiple input conditions to determine the worst-case setup for SETs. The unit was tested with V_{CC} of 5.5V and V_{CC} of 1.1V . All combinations of VCC and scope trigger configurations showed no transient upsets, as listed in [Table 5-2](#)

To capture SETs, one NI PXI-5110 scope card was used to continuously monitor the output voltage on pin Y. The scope monitoring the square wave output signal was configured to a voltage trigger of ±2%. The NI scopes were programmed to a sample rate of 100M samples per second (S/s) and recorded 1000 samples, with a 2% pretrigger reference, in case of an event (trigger). The setup was verified for each run to ensure no false triggers was captured before the beam was turned on. The ±2% threshold on the square wave outputs was determined to be the lowest threshold capable of not providing false triggers due to noise.

Under heavy-ions, the SN54SC1G125-SEP did not exhibit any transient upsets.

Table 5-2. Summary of SN54SC1G125-SEP SET Test Condition and Results

Run Number	Unit Number	Voltage Level	Temperature (°C)	Ion	LET _{EFF} (MeV × cm ² /mg)	FLUX (ions × cm ² /mg)	Fluence (Number ions)	Voltage Trigger	SET Upsets
11	2	5.5V	25	Xe	47	1.00E+05	1.00E+07	2%	0
12	2	1.1V	25	Xe	47	1.00E+05	1.00E+07	2%	0

Using the MFTF method shown in [Single-Event Effects \(SEE\) Confidence Internal Calculations](#), the upper-bound cross section (using a 95% confidence level) is calculated as:

$$\sigma_{\text{SET}} \leq 3.69 \times 10^{-7} \text{ cm}^2/\text{device for } \text{LET}_{\text{EFF}} = 47 \text{ MeV} \cdot \text{cm}^2/\text{mg} \text{ and } T = 25^\circ\text{C} \quad (2)$$

6 Event Rate Calculations

Event rates were calculated for LEO (ISS) and GEO environments by combining CREME96 orbital integral flux estimations and simplified SEE cross sections according to methods described in [Heavy Ion Orbital Environment Single-Event Effects Estimations application report](#). We assume a minimum shielding configuration of 100 mils (2.54mm) of aluminum, and *worst-week* solar activity (this is similar to a 99% upper bound for the environment). [Table 6-1](#) and [Table 6-2](#) provide the event rate calculation using the 95% upper bounds for the SEL and the SET, respectively.

Note

It is important to note that this number is for reference since no SEL or SET events were observed.

Table 6-1. SEL Event Rate Calculations for Worst-Week LEO and GEO Orbits

Orbit Type	Onset LET _{EFF} (MeV-cm ² /mg)	CREME96 Integral FLUX (/day/cm ²)	σSAT (cm ²)	Event Rate (/day)	Event Rate (FIT)	MTBF (Years)
LEO (ISS)	47	4.72 × 10 ⁻⁴	3.69 × 10 ⁻⁸	1.74 × 10 ⁻¹¹	7.26 × 10 ⁻⁴	1.57 × 10 ⁸
GEO		1.55 × 10 ⁻³		5.73 × 10 ⁻¹¹	2.39 × 10 ⁻³	4.52 × 10 ⁷

Table 6-2. SET Event Rate Calculations for Worst-Week LEO and GEO Orbits

Orbit Type	Onset LET _{EFF} (MeV-cm ² /mg)	CREME96 Integral FLUX (/day/cm ²)	σSAT (cm ²)	Event Rate (/day)	Event Rate (FIT)	MTBF (Years)
LEO (ISS)	47	4.72 × 10 ⁻⁴	3.69 × 10 ⁻⁷	1.74 × 10 ⁻¹⁰	7.26 × 10 ⁻³	1.57 × 10 ⁷
GEO		1.55 × 10 ⁻³		5.73 × 10 ⁻¹⁰	2.39 × 10 ⁻²	4.728 × 10 ⁶

7 Summary

The purpose of this study was to characterize the effects of heavy-ion irradiation on the single-event latch-up (SEL) performance of the SN54SC1G125-SEP radiation-tolerant, single 2-input positive-AND gate. SEE performance was verified at minimum (1.1V) and maximum (5.5V) operating conditions. Heavy-ions with an LET_{EFF} of 47MeV-cm²/mg were used to irradiate three production devices with a fluence of 1×10^7 ions/cm². The results demonstrate that the SN54SC1G125-SEP is SEL-free up to $LET_{EFF} = 47\text{MeV-cm}^2/\text{mg}$ as 125°C. SET performance for the minimum and maximum operating voltage saw no excursions $\geq 2\%$, as shown and discussed in this report.

8 References

1. M. Shoga and D. Binder, "Theory of Single Event Latchup in Complementary Metal-Oxide Semiconductor Integrated Circuits", *IEEE Trans. Nucl. Sci.*, Vol. 33(6), Dec. 1986, pp. 1714-1717.
2. G. Bruguier and J. M. Palau, "Single particle-induced latchup", *IEEE Trans. Nucl. Sci.*, Vol. 43(2), Mar. 1996, pp. 522-532.
3. Texas A&M University, [Texas A&M University Cyclotron Institute Radiation Effects Facility](#), webpage.
4. James F. Ziegler, [The Stopping and Range of Ions in Matter \(SRIM\)](#), webpage.
5. D. Kececioglu, "Reliability and Life Testing Handbook", Vol. 1, PTR Prentice Hall, New Jersey, 1993, pp. 186-193.
6. Vanderbilt University, [ISDE CRÈME-MC](#), webpage.
7. A. J. Tylka, J. H. Adams, P. R. Boberg, et al., "CREME96: A Revision of the Cosmic Ray Effects on Micro-Electronics Code", *IEEE Trans. on Nucl. Sci.*, Vol. 44(6), Dec. 1997, pp. 2150-2160.
8. A. J. Tylka, W. F. Dietrich, and P. R. Boberg, "Probability distributions of high-energy solar-heavy-ion fluxes from IMP-8: 1973-1996", *IEEE Trans. on Nucl. Sci.*, Vol. 44(6), Dec. 1997, pp. 2140-2149.

IMPORTANT NOTICE AND DISCLAIMER

TI PROVIDES TECHNICAL AND RELIABILITY DATA (INCLUDING DATASHEETS), DESIGN RESOURCES (INCLUDING REFERENCE DESIGNS), APPLICATION OR OTHER DESIGN ADVICE, WEB TOOLS, SAFETY INFORMATION, AND OTHER RESOURCES "AS IS" AND WITH ALL FAULTS, AND DISCLAIMS ALL WARRANTIES, EXPRESS AND IMPLIED, INCLUDING WITHOUT LIMITATION ANY IMPLIED WARRANTIES OF MERCHANTABILITY, FITNESS FOR A PARTICULAR PURPOSE OR NON-INFRINGEMENT OF THIRD PARTY INTELLECTUAL PROPERTY RIGHTS.

These resources are intended for skilled developers designing with TI products. You are solely responsible for (1) selecting the appropriate TI products for your application, (2) designing, validating and testing your application, and (3) ensuring your application meets applicable standards, and any other safety, security, regulatory or other requirements.

These resources are subject to change without notice. TI grants you permission to use these resources only for development of an application that uses the TI products described in the resource. Other reproduction and display of these resources is prohibited. No license is granted to any other TI intellectual property right or to any third party intellectual property right. TI disclaims responsibility for, and you fully indemnify TI and its representatives against any claims, damages, costs, losses, and liabilities arising out of your use of these resources.

TI's products are provided subject to [TI's Terms of Sale](#), [TI's General Quality Guidelines](#), or other applicable terms available either on ti.com or provided in conjunction with such TI products. TI's provision of these resources does not expand or otherwise alter TI's applicable warranties or warranty disclaimers for TI products. Unless TI explicitly designates a product as custom or customer-specified, TI products are standard, catalog, general purpose devices.

TI objects to and rejects any additional or different terms you may propose.

Copyright © 2026, Texas Instruments Incorporated

Last updated 10/2025