

LP2996-N、LP2996A DDR終端レギュレータ

1 特長

- 最小 V_{DDQ} :
 - 1.8V (LP2996-N)
 - 1.35V (LP2996A)
- ソースおよびシンク電流
- 低い出力電圧オフセット
- 出力電圧の設定に外付け抵抗が不要
- リニア・トポロジ
- Suspend-to-RAM (STR)機能
- 適切なESRのセラミック・コンデンサで安定
- 少ない外付け部品数
- サーマル・シャットダウン

2 アプリケーション

- LP2996-N: DDR1およびDDR2の終端電圧
- LP2996A: DDR1、DDR2、DDR3、DDR3Lの終端電圧
- FPGA
- 産業用および医療用PC
- SSTL-2およびSSTL-3の終端
- HSTLの終端

3 概要

LP2996-NおよびLP2996Aリニア・レギュレータは、DDR-SDRAMに関するJEDEC SSTL-2仕様を満たすよう設計されています。これらのデバイスはDDR2もサポートしています。LP2996AはDDR3およびDDR3L VTTバスの終端をサポートし、 V_{DDQ} の最小値は1.35Vです。これらのデバイスには高速のオペアンプが搭載されているため、負荷過渡応答が非常に優れています。出力ステージでは貫通電流が防止され、DDR-SDRAM終端での必要に応じて、アプリケーションで1.5Aの連続的な電流と、最大3Aの過渡ピーク電流を供給できます。LP2996-NおよびLP2996Aには V_{SENSE} ピンも搭載され、優れた負荷レギュレーションを行うとともに、チップセットとDIMMの基準電圧として V_{REF} 出力を供給します。

LP2996-NおよびLP2996Aには追加機能として、アクティブLOWのシャットダウン(\overline{SD})ピンがあり、Suspend-to-RAM (STR)機能を提供します。 \overline{SD} がLOWに設定されると、VTT出力がtri-stateになり、高インピーダンス出力を供給しますが、 V_{REF} はアクティブに維持されます。このモードでは、低い静止電流によって消費電力を削減できます。

LP2998およびLP2998-Q1デバイスは、車載用途およびDDRアプリケーションで、氷点下の温度で動作が必要とされる場合にお勧めします。

アプリケーション設計者はWEBENCH®設計ツールを使用して、LP2998およびLP2998-Q1を使用するアプリケーションの生成、最適化、シミュレーションを実行できます。

製品情報(1)

型番	パッケージ	本体サイズ(公称)
LP2996-N	SOIC (8)	4.90mmx3.90mm
LP2996-N、LP2996A	WSON (8)	4.90mmx3.90mm
LP2996-N	WQFN (16)	4.00mmx4.00mm

(1) 利用可能なすべてのパッケージについては、このデータシートの末尾にある注文情報を参照してください。

概略回路図

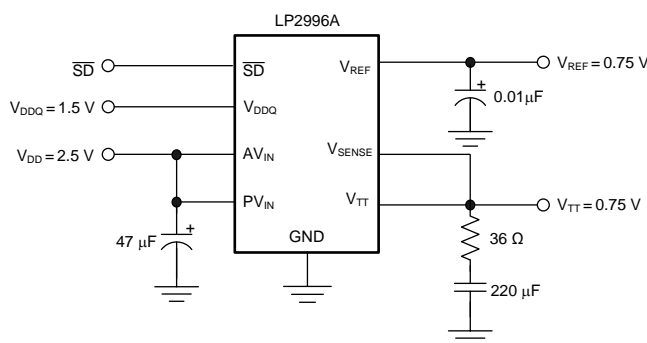

Copyright © 2016, Texas Instruments Incorporated

目次

1	特長	1	8	Applications and Implementation	12
2	アプリケーション	1	8.1	Application Information	12
3	概要	1	8.2	Typical Applications	12
4	改訂履歴	2	9	Power Supply Recommendations	18
5	Pin Configuration and Functions	3	10	Layout	19
6	Specifications	5	10.1	Layout Guidelines	19
6.1	Absolute Maximum Ratings	5	10.2	Layout Examples	19
6.2	ESD Ratings	5	10.3	Thermal Considerations	20
6.3	Recommended Operating Conditions	5	11	デバイスおよびドキュメントのサポート	23
6.4	Thermal Information	5	11.1	ドキュメントのサポート	23
6.5	Electrical Characteristics	6	11.2	関連リンク	23
6.6	Typical Characteristics	7	11.3	ドキュメントの更新通知を受け取る方法	23
7	Detailed Description	10	11.4	コミュニティ・リソース	23
7.1	Overview	10	11.5	商標	23
7.2	Functional Block Diagram	10	11.6	静電気放電に関する注意事項	23
7.3	Feature Description	11	11.7	用語集	23
7.4	Device Functional Modes	11	12	メカニカル、パッケージ、および注文情報	23

4 改訂履歴

資料番号末尾の英字は改訂を表しています。その改訂履歴は英語版に準じています。

Revision J (March 2013) から Revision K に変更	Page
<ul style="list-style-type: none"> 「製品情報」表、「仕様」セクション、「ESD定格」表、「熱に関する情報」セクション、「機能説明」セクション、「デバイスの機能モード」セクション、「アプリケーションと実装」セクション、「電源に関する推奨事項」セクション、「レイアウト」セクション、「デバイスおよびドキュメントのサポート」セクション、「メカニカル、パッケージ、および注文情報」セクション 追加 	1
<ul style="list-style-type: none"> データシート全体にLP2996A 追加 	1
<ul style="list-style-type: none"> データシート全体にDDR3サポート 追加 	1
<ul style="list-style-type: none"> Deleted Lead temperature (260°C maximum) from <i>Absolute Maximum Ratings</i> 	5
<ul style="list-style-type: none"> Changed Thermal Resistance, $R_{\theta JA}$, values in <i>Thermal Information</i> From: 151°C/W To: 119.5°C/W (SOIC), From: 151°C/W To: 56.5°C/W (SO), and From: 151°C/W To: 52.7°C/W (WQFN) 	5

Revision I (March 2013) から Revision J に変更	Page
<ul style="list-style-type: none"> ナショナル・セミコンダクターのデータシートのレイアウトをTIフォーマットに変更 	1
<ul style="list-style-type: none"> V_{DDQ} 範囲 追加 	1

5 Pin Configuration and Functions

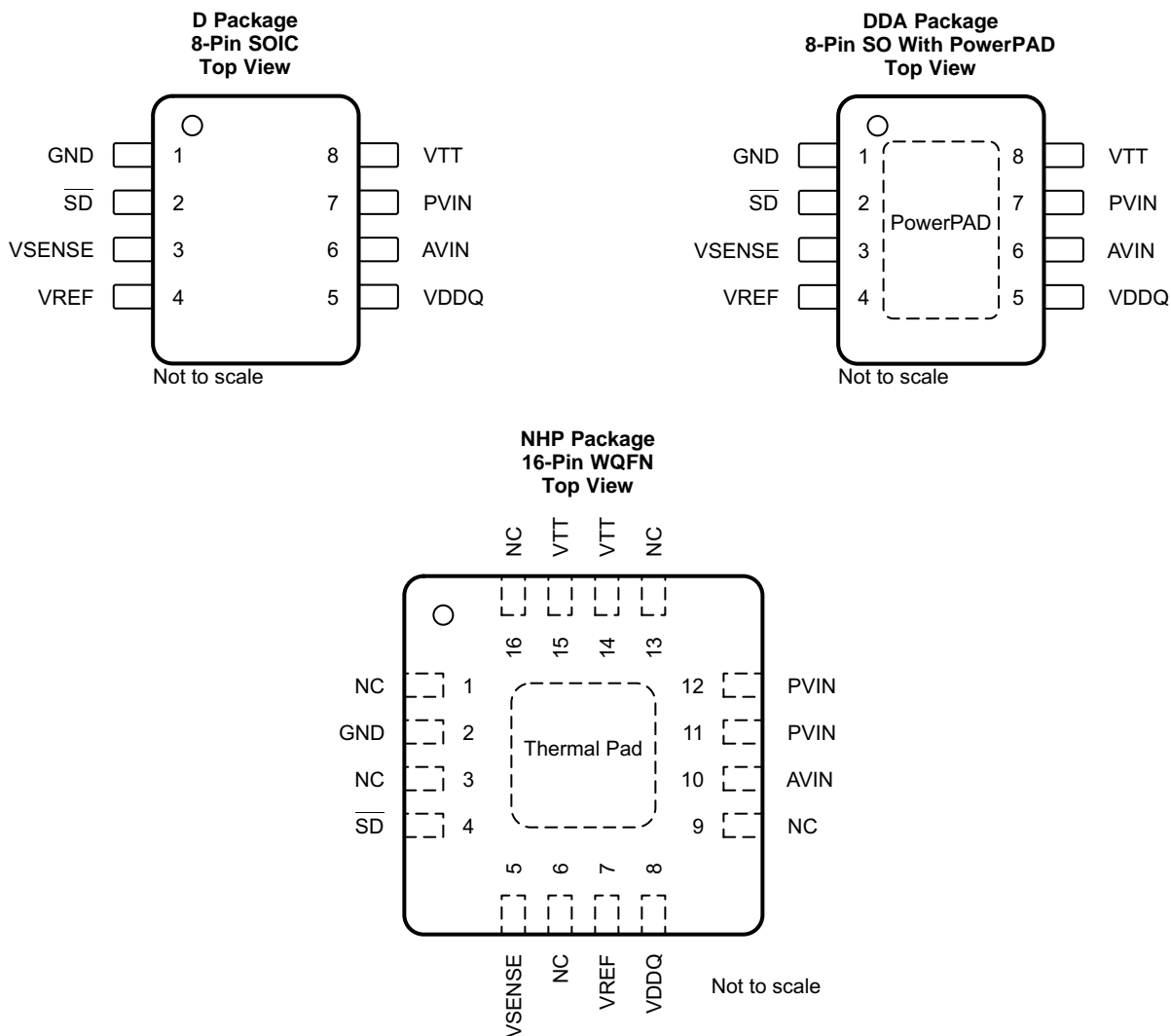

Pin Functions

NAME	PIN			I/O	DESCRIPTION
	SO PowerPAD	SOIC	WQFN		
AVIN	6	6	10	I	Analog input pin. AVIN is used to supply all the internal control circuitry. This pin has the capability to work from a supply separate from PVIN depending on the application. For SSTL-2 applications, a good compromise would be to connect the AVIN and PVIN directly together at 2.5 V. This eliminates the requirement for bypassing the two supply pins separately. The only limitation on input voltage selection is that PV _{IN} must be equal to or lower than AV _{IN} .
GND	1	1	2	—	Ground
PVIN	7	7	11, 12	I	Power input pin. PVIN is used exclusively to provide the rail voltage for the output stage used to create VTT. This pin has the capability to work from a supply separate from PVIN depending on the application. Higher voltages on PVIN increases the maximum continuous output current because of output R _{DS(ON)} limitations at voltages close to VTT. The disadvantage of high values of PV _{IN} is that the internal power loss also increases, thermally limiting the design. For SSTL-2 applications, a good compromise would be to connect the AVIN and PVIN directly together at 2.5 V. This eliminates the requirement for bypassing the two supply pins separately. The only limitation on input voltage selection is that PV _{IN} must be equal to or less than AV _{IN} . TI recommends connecting PVIN to voltage rails equal to or less than 3.3 V to prevent the thermal limit from tripping because of excessive internal power dissipation. If the junction temperature exceeds the thermal shutdown then the part enters a shutdown state identical to the manual shutdown where VTT is tri-stated and VREF remains active.

Pin Functions (continued)

PIN				I/O	DESCRIPTION
NAME	SO PowerPAD	SOIC	WQFN		
\overline{SD}	2	2	4	I	Shutdown. The LP2996-N and LP2996A contain an active low shutdown pin that can be used to tri-state VTT. During shutdown VTT must not be exposed to voltages that exceed AVIN. With the shutdown pin asserted low the quiescent current of the LP2996-N and LP2996A drops, however, VDDQ always maintains its constant impedance of 100 kΩ for generating the internal reference. Therefore, to calculate the total power loss in shutdown, both currents must be considered. See Thermal Considerations for more information. The shutdown pin also has an internal pullup current, therefore to turn the part on, the shutdown pin can either be connected to AVIN or left open.
VDDQ	5	5	8	I	Input for internal reference equal to VDDQ / 2. VDDQ is the input used to create the internal reference voltage for regulating VTT. The reference voltage is generated from a resistor divider of two internal 50-kΩ resistors. This ensures that VTT tracks VDDQ / 2 precisely. The optimal implementation of VDDQ is as a remote sense. This can be achieved by connecting VDDQ directly to the 2.5-V rail at the DIMM instead of AVIN and PVIN. This ensures that the reference voltage tracks the DDR memory rails precisely without a large voltage drop from the power lines. For SSTL-2 applications VDDQ is a 2.5-V signal, which creates a 1.25-V termination voltage at VTT. See Electrical Characteristics for exact values of VTT over temperature.
VREF	4	4	7	O	Buffered internal reference voltage of VDDQ / 2. VREF provides the buffered output of the internal reference voltage VDDQ / 2. This output must be used to provide the reference voltage for the Northbridge chipset and memory. Because these inputs are typically an extremely high impedance, there must be little current drawn from VREF. For improved performance, an output bypass capacitor can be placed close to the pin to help reduce noise. TI recommends a ceramic capacitor from 0.1 μF to 0.01 μF. This output remains active during the shutdown state and thermal shutdown events for the suspend to RAM functionality.
VSENSE	3	3	5	I	Feedback pin for regulating VTT. The purpose of the sense pin is to provide improved remote load regulation. In most motherboard applications the termination resistors connect to VTT in a long plane. If the output voltage was regulated only at the output of the device then the long trace causes a significant IR drop resulting in a termination voltage lower at one end of the bus than the other. The VSENSE pin can be used to improve this performance by connecting it to the middle of the bus. This provides a better distribution across the entire termination bus. If remote load regulation is not used then the VSENSE pin must still be connected to VTT. Take care when a long VSENSE trace is implemented in close proximity to the memory. Noise pickup in the VSENSE trace can cause problems with precise regulation of VTT. A small 0.1-μF ceramic capacitor placed next to the VSENSE pin can help filter any high frequency signals and preventing errors.
VTT	8	8	14, 15	O	Output voltage for connection to termination resistors. VTT is the regulated output that is used to terminate the bus resistors. It is capable of sinking and sourcing current while regulating the output precisely to VDDQ / 2. The LP2996-N and LP2996A are designed to handle peak transient currents of up to ±3 A with a fast transient response. The maximum continuous current is a function of VDD and can be seen in Typical Characteristics . If a transient above the maximum continuous current rating is expected to last for a significant amount of time then the output capacitor must be large enough to prevent an excessive voltage drop. Despite the fact that the device is designed to handle large transient output currents it is not capable of handling these for long durations under all conditions. The reason for this is the standard packages are not able to thermally dissipate the heat as a result of the internal power loss. If large currents are required for longer durations, then ensure that the maximum junction temperature is not exceeded. Proper thermal derating must always be used (see Thermal Considerations). If the junction temperature exceeds the thermal shutdown point then VTT tri-states until the part returns below the hysteretic trip-point.
NC	—	—	1, 3, 6, 9, 13, 16	—	No internal connection
Thermal Pad	PowerPAD	—	Thermal Pad	—	Exposed pad thermal connection. Connect to Ground.

6 Specifications

6.1 Absolute Maximum Ratings

over operating free-air temperature range (unless otherwise noted)⁽¹⁾⁽²⁾

	MIN	MAX	UNIT
AVIN to GND	-0.3	6	V
PVIN to GND	-0.3	AV _{IN}	V
Input voltage (VDDQ) ⁽³⁾	-0.3	6	V
Junction temperature, T _J		150	°C
Storage temperature, T _{stg}	-65	150	°C

- (1) Stresses beyond those listed under *Absolute Maximum Ratings* may cause permanent damage to the device. These are stress ratings only, which do not imply functional operation of the device at these or any other conditions beyond those indicated under *Recommended Operating Conditions*. Exposure to absolute-maximum-rated conditions for extended periods may affect device reliability.
- (2) If Military/Aerospace specified devices are required, please contact the Texas Instruments Sales Office/Distributors for availability and specifications.
- (3) VDDQ voltage must be less than 2 × (AV_{IN} – 1) or 6 V, whichever is smaller.

6.2 ESD Ratings

	VALUE	UNIT
V _(ESD) Electrostatic discharge Human-body model (HBM), per ANSI/ESDA/JEDEC JS-001 ⁽¹⁾	±1000	V

- (1) The human body model is a 100-pF capacitor discharged through a 1.5-kΩ resistor into each pin.

6.3 Recommended Operating Conditions

over operating free-air temperature range (unless otherwise noted)

	MIN	MAX	UNIT
AVIN to GND	2.2	5.5	V
PVIN supply voltage	0	AV _{IN}	V
\overline{SD} input voltage	0	AV _{IN}	V
T _J Junction temperature ⁽¹⁾	0	125	°C

- (1) At elevated temperatures, devices must be derated based on thermal resistance.

6.4 Thermal Information

THERMAL METRIC	LP2996-N, LP2996A			UNIT
	D (SOIC)	DDA (SO)	NHP (WQFN)	
	8 PINS	8 PINS	16 PINS	
R _{θJA} Junction-to-ambient thermal resistance	119.5	56.5	52.7	°C/W
R _{θJC(top)} Junction-to-case (top) thermal resistance	65.3	65.1	50.1	°C/W
R _{θJB} Junction-to-board thermal resistance	59.8	36.5	30.1	°C/W
Ψ _{JT} Junction-to-top characterization parameter	16.7	15.9	0.7	°C/W
Ψ _{JB} Junction-to-board characterization parameter	59.3	36.5	30.2	°C/W
R _{θJC(bot)} Junction-to-case (bottom) thermal resistance	—	8.4	9.8	°C/W

6.5 Electrical Characteristics

Minimum and maximum limits apply over the full operating temperature range ($T_J = 0^\circ\text{C}$ to 125°C) and are specified through test, design, or statistical correlation. Typical values represent the most likely parametric norm ($T_J = 25^\circ\text{C}$), and are provided for reference purposes only. Unless otherwise specified, $AV_{IN} = PV_{IN} = 2.5\text{ V}$ and $V_{DDQ} = 2.5\text{ V}$.⁽¹⁾

PARAMETER		TEST CONDITIONS	MIN	TYP	MAX	UNIT	
V _{REF}	V _{REF} voltage (DDR I)	V _{DD} = V _{DDQ} = 2.3 V	1.135	1.158	1.185	V	
		V _{DD} = V _{DDQ} = 2.5 V	1.235	1.258	1.285		
		V _{DD} = V _{DDQ} = 2.7 V	1.335	1.358	1.385		
	V _{REF} voltage (DDR II)	PV _{IN} = V _{DDQ} = 1.7 V	0.837	0.86	0.887	V	
		PV _{IN} = V _{DDQ} = 1.8 V	0.887	0.91	0.937		
		PV _{IN} = V _{DDQ} = 1.9 V	0.936	0.959	0.986		
	V _{REF} voltage (DDR III)	PV _{IN} = V _{DDQ} = 1.35 V	0.669	0.684	0.699	V	
		PV _{IN} = V _{DDQ} = 1.5 V	0.743	0.758	0.773		
		PV _{IN} = V _{DDQ} = 1.6 V	0.793	0.808	0.823		
Z _{VREF}	V _{REF} output impedance	I _{REF} = -30 to 30 μA		2.5		kΩ	
V _{TT}	V _{TT} output voltage (DDR I) ⁽²⁾	I _{OUT} = 0 A	V _{DD} = V _{DDQ} = 2.3 V	1.12	1.159	1.19	V
			V _{DD} = V _{DDQ} = 2.5 V	1.21	1.259	1.29	
			V _{DD} = V _{DDQ} = 2.7 V	1.32	1.359	1.39	
		I _{OUT} = ±1.5 A	V _{DD} = V _{DDQ} = 2.3 V	1.125	1.159	1.19	
			V _{DD} = V _{DDQ} = 2.5 V	1.225	1.259	1.29	
			V _{DD} = V _{DDQ} = 2.7 V	1.325	1.359	1.39	
V _{TT} output voltage (DDR II) ⁽²⁾	I _{OUT} = 0 A, AV _{IN} = 2.5 V	PV _{IN} = V _{DDQ} = 1.7 V	0.822	0.856	0.887	V	
		PV _{IN} = V _{DDQ} = 1.8 V	0.874	0.908	0.939		
		PV _{IN} = V _{DDQ} = 1.9 V	0.923	0.957	0.988		
	I _{OUT} = ±0.5 A, AV _{IN} = 2.5 V	PV _{IN} = V _{DDQ} = 1.7 V	0.82	0.856	0.89		
		PV _{IN} = V _{DDQ} = 1.8 V	0.87	0.908	0.94		
		PV _{IN} = V _{DDQ} = 1.9 V	0.92	0.957	0.99		
V _{TT} output voltage (DDR III) ⁽²⁾	I _{OUT} = 0 A, AV _{IN} = 2.5 V	PV _{IN} = V _{DDQ} = 1.35 V	0.656	0.677	0.698	V	
		PV _{IN} = V _{DDQ} = 1.5 V	0.731	0.752	0.773		
		PV _{IN} = V _{DDQ} = 1.6 V	0.781	0.802	0.823		
	I _{OUT} = 0.2 A, AV _{IN} = 2.5 V, PV _{IN} = V _{DDQ} = 1.35 V	0.667	0.688	0.71			
	I _{OUT} = -0.2 A, AV _{IN} = 2.5 V, PV _{IN} = V _{DDQ} = 1.35 V	0.641	0.673	0.694			
	I _{OUT} = 0.4 A, AV _{IN} = 2.5 V, PV _{IN} = V _{DDQ} = 1.5 V	0.74	0.763	0.786			
	I _{OUT} = -0.4 A, AV _{IN} = 2.5 V, PV _{IN} = V _{DDQ} = 1.5 V	0.731	0.752	0.773			
	I _{OUT} = 0.5 A, AV _{IN} = 2.5 V, PV _{IN} = V _{DDQ} = 1.6 V	0.79	0.813	0.836			
	I _{OUT} = -0.5 A, AV _{IN} = 2.5 V, PV _{IN} = V _{DDQ} = 1.6 V	0.781	0.802	0.823			
VOS _{V_{TT}}	V _{TT} output voltage offset (V _{REF} - V _{TT}) for DDR I ⁽²⁾	I _{OUT} = 0 A	-30	0	30	mV	
		I _{OUT} = -1.5 A	-30	0	30		
		I _{OUT} = 1.5 A	-30	0	30		
	V _{TT} output voltage offset (V _{REF} - V _{TT}) for DDR II ⁽²⁾	I _{OUT} = 0 A	-30	0	30	mV	
		I _{OUT} = -0.5 A	-30	0	30		
		I _{OUT} = 0.5 A	-30	0	30		
	V _{TT} output voltage offset (V _{REF} - V _{TT}) for DDR III ⁽²⁾	I _{OUT} = 0 A	-30	0	30	mV	
		I _{OUT} = ±0.2 A	-30	0	30		
		I _{OUT} = ±0.4 A	-30	0	30		
	I _Q	Quiescent current ⁽³⁾	I _{OUT} = 0 A		320	500	μA

(1) V_{DD} is defined as V_{DD} = AV_{IN} = PV_{IN}.

(2) V_{TT} load regulation is tested by using a 10-ms current pulse and measuring V_{TT}.

(3) Quiescent current defined as the current flow into AV_{IN}.

Electrical Characteristics (continued)

Minimum and maximum limits apply over the full operating temperature range ($T_J = 0^{\circ}\text{C}$ to 125°C) and are specified through test, design, or statistical correlation. Typical values represent the most likely parametric norm ($T_J = 25^{\circ}\text{C}$), and are provided for reference purposes only. Unless otherwise specified, $AV_{IN} = PV_{IN} = 2.5\text{ V}$ and $V_{DDQ} = 2.5\text{ V}$.⁽¹⁾

PARAMETER	TEST CONDITIONS	MIN	TYP	MAX	UNIT
Z_{VDDQ}	VDDQ input impedance		100		k Ω
I_{SD}	Quiescent current in shutdown ⁽³⁾		115	150	μA
I_{Q_SD}	Shutdown leakage current		2	5	μA
V_{IH}	Minimum shutdown, high level	1.9			V
V_{IL}	Maximum shutdown, low level			0.8	V
I_V	V_{TT} leakage current in shutdown		1	10	μA
I_{SENSE}	V_{SENSE} input current		13		nA
T_{SD}	Thermal shutdown		165		$^{\circ}\text{C}$
T_{SD_HYS}	Thermal shutdown hysteresis		10		$^{\circ}\text{C}$

6.6 Typical Characteristics

Unless otherwise specified, $AV_{IN} = PV_{IN} = 2.5\text{ V}$.

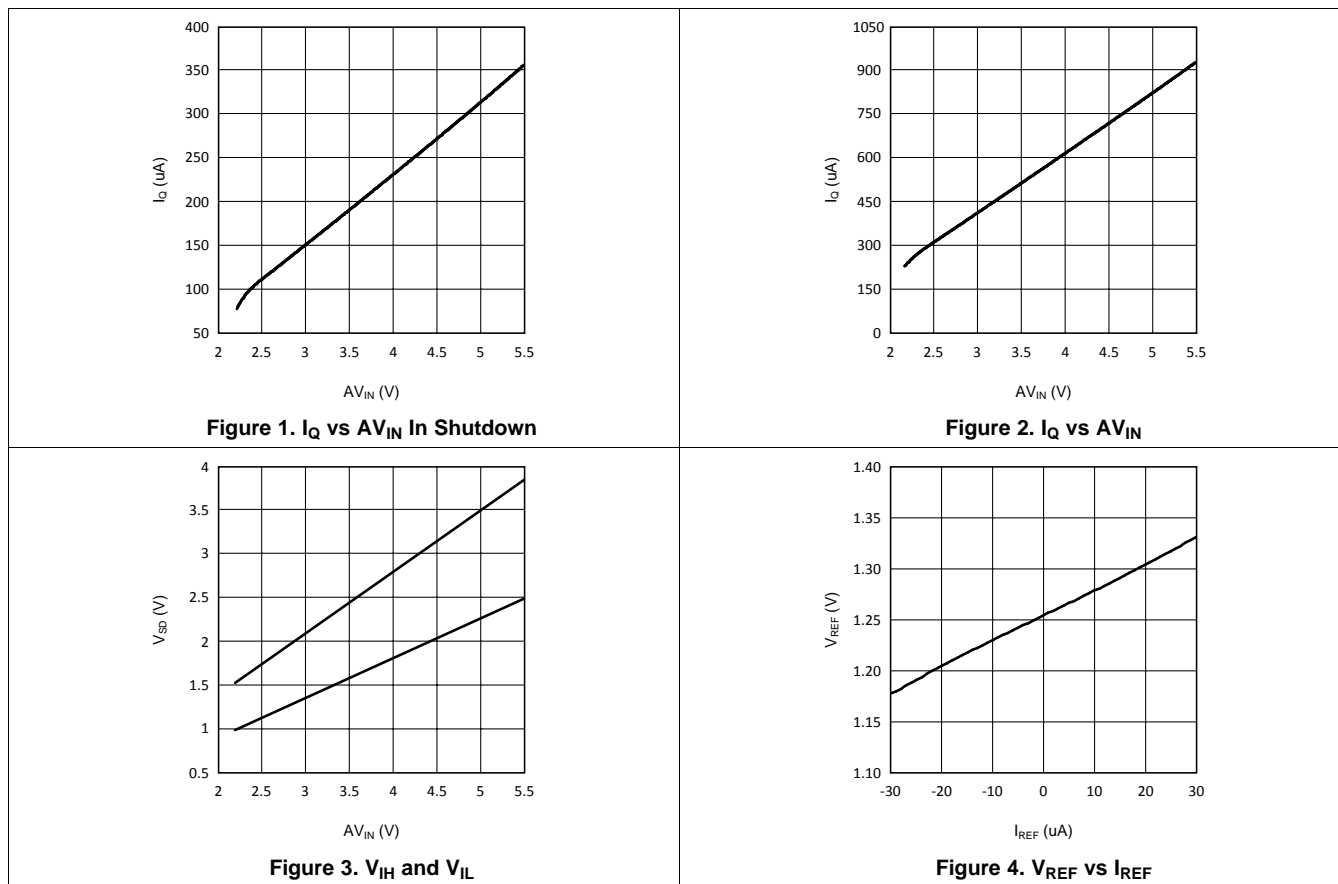

Typical Characteristics (continued)

Unless otherwise specified, $AV_{IN} = PV_{IN} = 2.5 \text{ V}$.

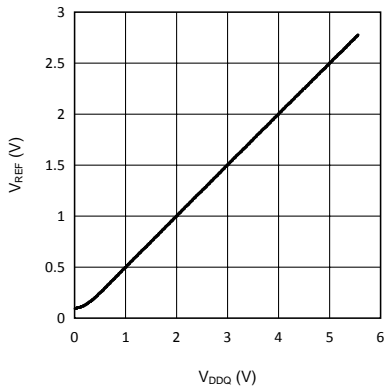

Figure 5. V_{REF} vs V_{DDQ}

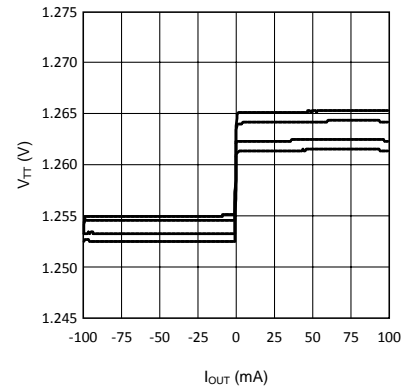

Figure 6. V_{TT} vs I_{OUT}

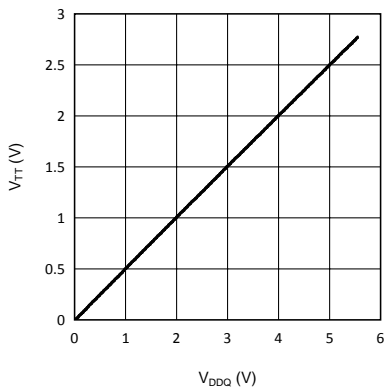

Figure 7. V_{TT} vs V_{DDQ}

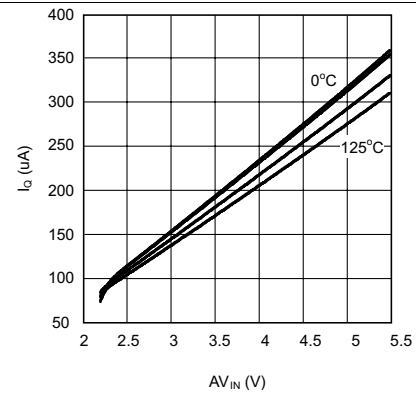

Figure 8. I_Q vs AV_{IN} in Shutdown Temperature

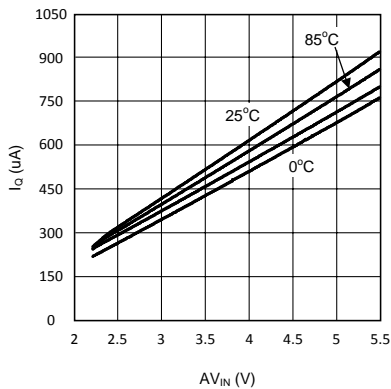
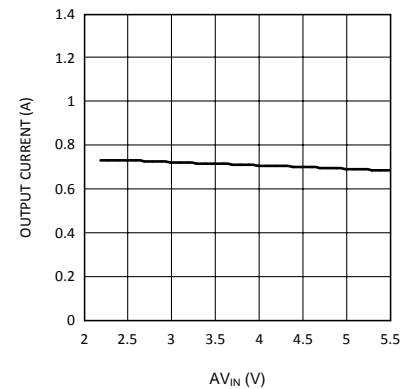

Figure 9. I_Q vs AV_{IN} Temperature



$V_{DDQ} = 2.5 \text{ V}$ $PV_{IN} = 1.8 \text{ V}$

Figure 10. Maximum Sourcing Current vs AV_{IN}

Typical Characteristics (continued)

Unless otherwise specified, $AV_{IN} = PV_{IN} = 2.5\text{ V}$.

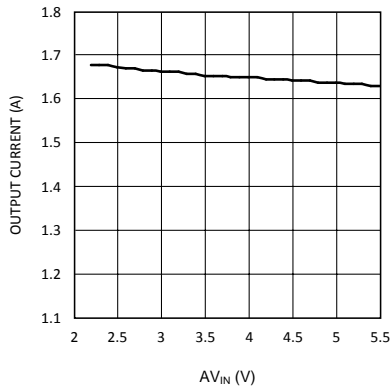

$V_{DDQ} = 2.5\text{ V}$ $PV_{IN} = 2.5\text{ V}$

Figure 11. Maximum Sourcing Current vs AV_{IN}

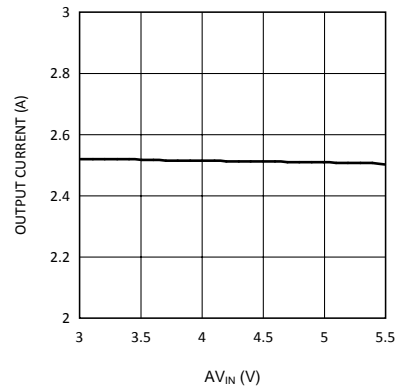

$V_{DDQ} = 2.5\text{ V}$ $PV_{IN} = 3.3\text{ V}$

Figure 12. Maximum Sourcing Current vs AV_{IN}

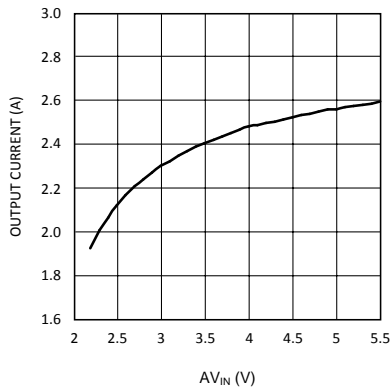

$V_{DDQ} = 2.5\text{ V}$

Figure 13. Maximum Sinking Current vs AV_{IN}

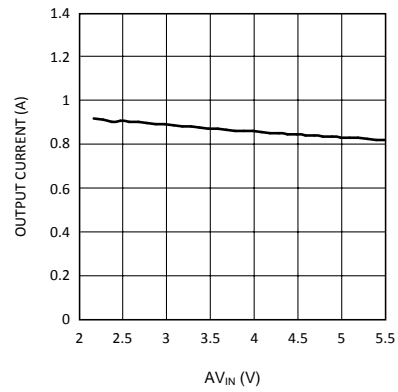

$V_{DDQ} = 1.8\text{ V}$ $PV_{IN} = 1.8\text{ V}$

Figure 14. Maximum Sourcing Current vs AV_{IN}

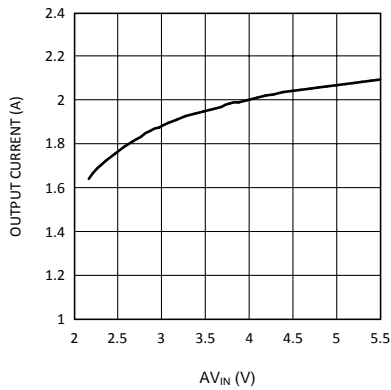

$V_{DDQ} = 1.8\text{ V}$

Figure 15. Maximum Sinking Current vs AV_{IN}

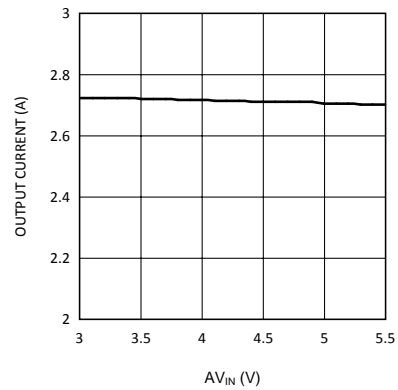

$V_{DDQ} = 1.8\text{ V}$ $PV_{IN} = 3.3\text{ V}$

Figure 16. Maximum Sourcing Current vs AV_{IN}

7 Detailed Description

7.1 Overview

The LP2996-N and LP2996A devices can be used to provide a termination voltage for additional logic schemes such as SSTL-3 or HSTL.

Series Stub Termination Logic (SSTL) was created to improve signal integrity of the data transmission across the memory bus. This termination scheme is essential to prevent data error from signal reflections while transmitting at high frequencies encountered with DDR-SDRAM. The most common form of termination is Class II single parallel termination. This involves one R_S series resistor from the chipset to the memory and one R_T termination resistor. Typical values for R_S and R_T are $25\ \Omega$, although these can be changed to scale the current requirements from the LP2996-N or LP2996A. This implementation is shown in Figure 17.

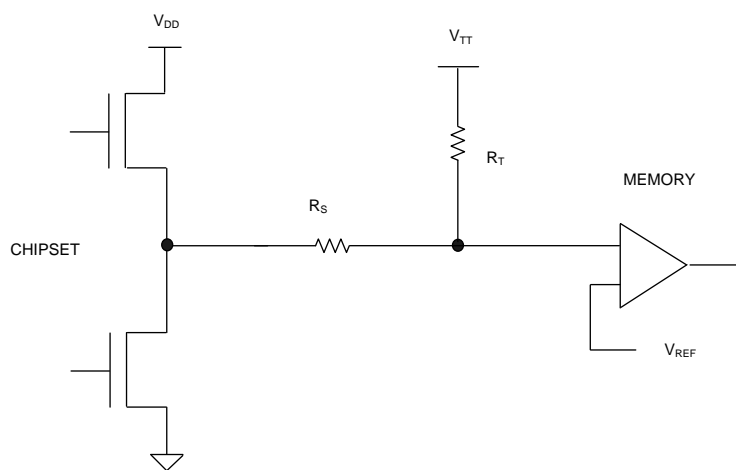
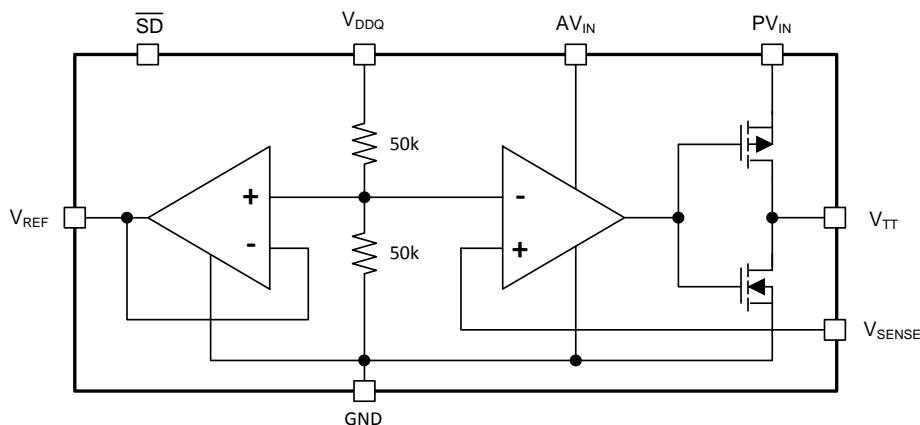

Figure 17. SSTL-Termination Scheme

7.2 Functional Block Diagram



Copyright © 2016, Texas Instruments Incorporated

7.3 Feature Description

The LP2996-N and LP2996A are linear bus termination regulators designed to meet the JEDEC requirements of SSTL-2. The output (V_{TT}) is capable of sinking and sourcing current while regulating the output voltage equal to $V_{DDQ} / 2$. The output stage is designed to maintain excellent load regulation while preventing shoot through. The LP2996-N and LP2996A also incorporate two distinct power rails that separates the analog circuitry from the power output stage. This allows a split rail approach to be used to decrease internal power dissipation. It also permits the LP2996-N to provide a termination solution for DDR2-SDRAM, while the LP2996A supports DDR3-SDRAM and DDR3L-SDRAM memory. TI recommends the LP2998 and LP2998-Q1 for all DDR applications that require operation at below-zero temperatures.

7.4 Device Functional Modes

7.4.1 Start-Up

During start up when VDDQ is enabled, the error amplifier senses the output voltage is low and drives the pass element hard causing a large inrush current. If this inrush current is too large, the device shuts down and restarts due to the internal current limit. Two solutions to prevent large inrush current during start up:

1. Slow down the slew rate of VDDQ. When the slew rate of VDDQ is fast (approximately 60 μ s), the input current can reach over 5 A which exceeds the device's current limit thus causing a restart. If VDDQ start-up slew rate is ≥ 300 μ s, the inrush current can be reduced by 90% limiting the input rush current to less than 500mA.
2. In some cases the system designers have very little to no control over the VDDQ voltage supply slew rate, whether using linear or switching regulators. Some step down voltage regulators do not have soft-start feature. VDDQ voltage source requires only 18 μ A current to enable the DDRII termination voltage. Therefore placing an RC filter at VDDQ pin can conveniently increase the output voltage slew rate, allowing a slow rise in capacitor charge current. To keep the VDDQ voltage losses minimum, the resistor value must be chosen carefully. Using a 100- Ω resistor keeps the VDDQ supply voltage losses down to 1.8 mV, because the current through VDDQ is only 18 μ A for DDRIII configuration.

See [Limiting DDR Termination Regulators' Inrush Current](#) (SNVA758) for more information relating to the inrush current during start up.

7.4.2 Normal Operation

The device contains a high-speed operational amplifier to provide excellent response to load transients. The output stage prevents shoot through while delivering 1.5-A continuous current and transient peaks up to 3 A in the application as required for DDR-SDRAM termination. The LP2996-N and LP2996A also incorporate a VSENSE pin to provide superior load regulation and a VREF output as a reference for the chipset and DIMMs. See [Electrical Characteristics](#) and [Application Information](#).

7.4.3 Shutdown

The LP2996-N and LP2996A feature an active-low shutdown (SD) pin that provides Suspend To RAM (STR) functionality. When SD is pulled low, the VTT output tri-states providing a high impedance output, but VREF remains active. A power savings advantage can be obtained in this mode through lower quiescent current. During shutdown, VTT must not be exposed to voltages that exceed AVIN. With the shutdown pin asserted low the quiescent current of the LP2996-N and LP2996A drops, however, VDDQ always maintains its constant impedance of 100 k Ω for generating the internal reference. Therefore, to calculate the total power loss in shutdown, both currents must be considered. The shutdown pin also has an internal pullup current, therefore to turn the part on, the shutdown pin can either be connected to AVIN or left open.

8 Applications and Implementation

NOTE

Information in the following applications sections is not part of the TI component specification, and TI does not warrant its accuracy or completeness. TI's customers are responsible for determining suitability of components for their purposes. Customers should validate and test their design implementation to confirm system functionality.

8.1 Application Information

The LP2996 has split rails to allow flexibility in powering the device. It has a control circuitry rail (AVIN) and an output power stage rail (PVIN), both separate from the reference voltage input (VDDQ). This allows for different setups which cater to specific requirements such as high current capabilities, lower thermal dissipation, or minimum component count. Because the output is always $V_{DDQ} / 2$ due to two internal 50-k Ω resistors, the only necessary external components are bypass capacitors.

8.2 Typical Applications

8.2.1 Typical SSTL-2 Application Circuit

This circuit permits termination in a minimum amount of board space and component count. Capacitor selection can be varied depending on the number of lines terminated and the maximum load transient. However, with motherboards and other applications where V_{TT} is distributed across a long plane, it is advisable to use multiple bulk capacitors and addition to high frequency decoupling.

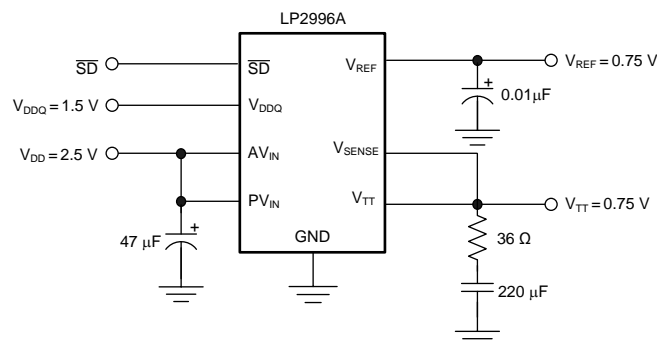

Copyright © 2016, Texas Instruments Incorporated

Figure 18. Typical SSTL-2 Application Circuit Diagram

8.2.1.1 Design Requirements

For this design example, use the parameters listed in [Table 1](#) as the input parameters.

Table 1. Design Parameters

PARAMETER	VALUE
V_{DDQ}	1.5 V
Input to AVIN and PVIN, V_{DD}	2.5 V
V_{REF}	0.75 V
V_{TT}	0.75 V
Input bypass capacitor, C_{IN}	47 μ F
Output bypass capacitor, C_{OUT}	220 μ F

8.2.1.2 Detailed Design Procedure

The LP2996 requires voltage be applied to three pins for proper operation: VDDQ, AVIN, and PVIN. VDDQ sets the internal reference voltage and is divided across two 50-k Ω resistors. Therefore, VDDQ must be set at exactly twice the appropriate DDR termination. AVIN powers the internal control circuitry and must be from 2.2 V to 5.5 V. PVIN is the supply for the power output stage and must be larger than or equal to VDDQ while smaller than or equal to AVIN. When picking PVIN, note that smaller values reduce internal power dissipation but reduce the maximum continuous current as well. It is acceptable to tie PVIN to either VDDQ or AVIN to minimize the number of supplies and bypass capacitors required.

To prevent voltage dips on the output, a bypass capacitor must be placed on the VTT line. The size of this capacitor does not affect stability, but larger values improve the transient response and must be sized according to the design requirements. When using ceramic capacitors on the output, large load steps can cause ringing on VTT. [Table 2](#) shows the range of acceptable equivalent series resistance (ESR) that can be added to dampen and improve the response.

Table 2. Approximate ESR Values for VTT Capacitors

VTT CAPACITANCE (μF)	RECOMMENDED ESR ($\text{m}\Omega$)
100	50
150	42
220	36
330	30

Another bypass capacitor on PVIN is recommended to keep current spikes from pulling down the input voltage. This is especially important if PVIN and VDDQ are on the same supply. A small 0.01- μF capacitor can be placed on VREF to reduce noise. VSENSE provides a feedback path necessary for regulating the output voltage; therefore, it must be connected to VTT. If a long VSENSE trace is necessary, a small ceramic capacitor may be required to filter out any high frequency noise picked up from switching I/O signals.

8.2.1.2.1 Input Capacitor

The LP2996-N and LP2996A do not require a capacitor for input stability, but it is recommended for improved performance during large load transients to prevent the input rail from dropping. The input capacitor must be placed as close as possible to the PVIN pin. Several recommendations exist dependent on the application required. A typical value recommended for aluminum electrolytic capacitors is 50 μF . Ceramic capacitors can also be used, a value approximately 10 μF with X5R or better would be an ideal choice. The input capacitance can be reduced if the LP2996-N or LP2996A is placed close to the bulk capacitance from the output of the 2.5-V DC-DC converter. If the two supply rails (AVIN and PVIN) are separated then the 47- μF capacitor must be placed as close to possible to the PVIN rail. An additional 0.1- μF ceramic capacitor can be placed on the AVIN rail to prevent excessive noise from coupling into the device.

8.2.1.2.2 Output Capacitor

The LP2996-N and LP2996A have been designed to be insensitive of output capacitor size or ESR. This allows the flexibility to use any capacitor desired. The choice for output capacitor is determined solely on the application and the requirements for load transient response of V_{TT} . TI recommends the output capacitor be sized above 100 μF with a low ESR for SSTL applications with DDR-SDRAM. The value of ESR is determined by the maximum current spikes expected and the extent at which the output voltage is allowed to droop. Several capacitor options are available on the market and a few of these are discussed: [Aluminum Electrolytics](#), [Ceramic Capacitors](#), and [Hybrid Capacitors](#).

8.2.1.2.2.1 Aluminum Electrolytics

Aluminum electrolytics often only specify impedance at a frequency of 120 Hz, indicating poor high frequency performance. Only aluminum electrolytics that specified an impedance at higher frequencies, from 20 kHz to 100 kHz, must be used for the LP2996-N and LP2996A. To improve the ESR, many aluminum electrolytics may be combined in parallel for an overall reduction. Be aware of the extent at which the ESR changes over temperature. Aluminum electrolytic capacitors' ESR may rapidly increase at cold temperatures.

8.2.1.2.2.2 Ceramic Capacitors

Ceramic capacitors typically have a low capacitance, from 10 μF to 100 μF , but they have excellent AC performance for bypassing noise due to very low ESR (typically less than 10 m Ω). However, some dielectric types do not have good capacitance characteristics as a function of voltage and temperature. Because of the typically low value of capacitance, TI recommends using ceramic capacitors in parallel with another capacitor such as an aluminum electrolytic. TI recommends dielectric of X5R or better for all ceramic capacitors.

8.2.1.2.2.3 Hybrid Capacitors

Hybrid capacitors offer a large capacitance while maintaining a low ESR. These are the best solution when size and performance are critical, although their cost is typically higher than any other capacitor.

8.2.1.2.2.4 PC Application Considerations

With motherboards and other applications where V_{TT} is distributed across a long plane, it is advisable to use multiple bulk capacitors and addition to high frequency decoupling. Figure 19 shows an example circuit where two bulk output capacitors could be situated at both ends of the V_{TT} plane for optimal placement. Large aluminum electrolytic capacitors are used for their low ESR and low cost.

In most PC applications an extensive amount of decoupling is required because of the long interconnects encountered with the DDR-SDRAM DIMMs mounted on modules. As a result bulk aluminum electrolytic capacitors approximately 1000 μF are typically used.

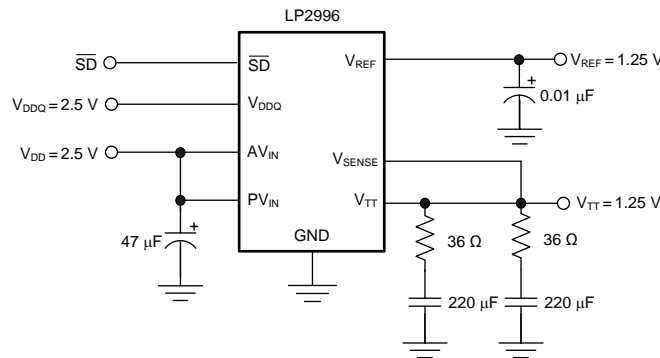

Copyright © 2016, Texas Instruments Incorporated

Figure 19. Typical SSTL-2 Application Circuit for Motherboards

8.2.1.3 Application Curves

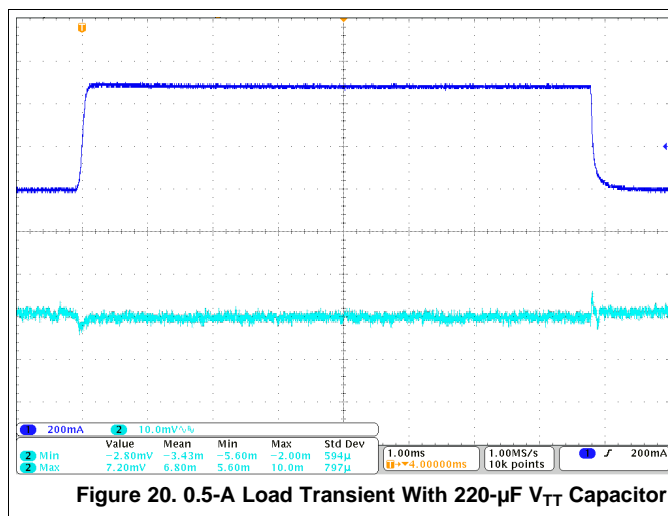

Figure 20. 0.5-A Load Transient With 220- μF V_{TT} Capacitor

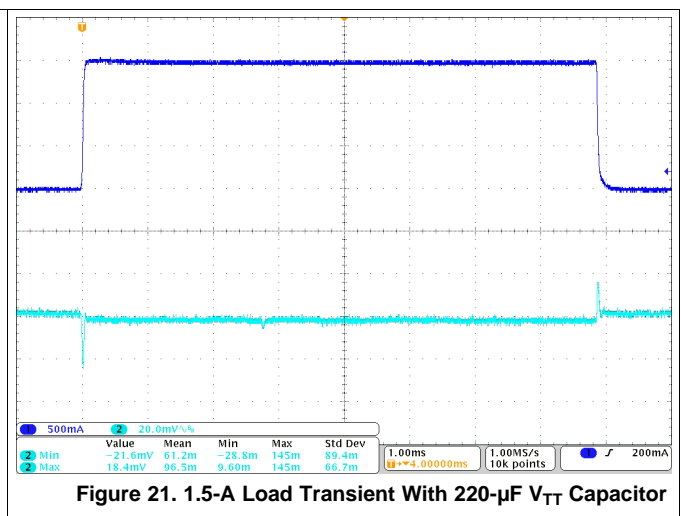

Figure 21. 1.5-A Load Transient With 220- μF V_{TT} Capacitor

8.2.2 Other Application Circuits

Several different application circuits are shown to illustrate some of the options that are possible in configuring the LP2996-N or LP2996A.

8.2.2.1 SSTL-2 Applications

For the majority of applications that implement the SSTL-2 termination scheme, TI recommends connecting all the input rails to the 2.5-V rail. This provides an optimal trade-off between power dissipation and component count and selection. An example of this circuit can be seen in [Figure 22](#).

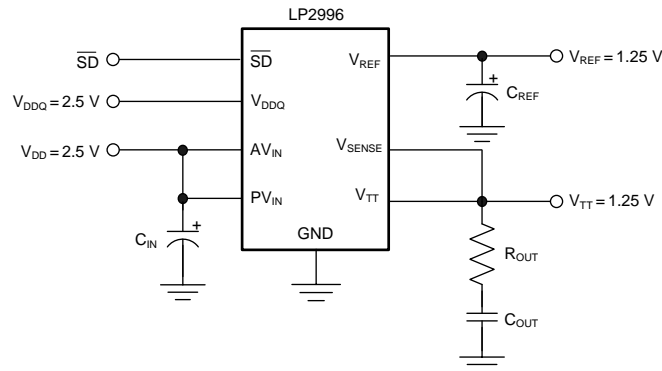

Copyright © 2016, Texas Instruments Incorporated

Figure 22. Recommended SSTL-2 Implementation

If power dissipation or efficiency is a major concern, then the LP2996-N or LP2996A has the ability to operate on split power rails. The output stage (PVIN) can be operated on a lower rail such as 1.8 V and the analog circuitry (AVIN) can be connected to a higher rail such as 2.5 V, 3.3 V, or 5 V. This allows the internal power dissipation to be lowered when sourcing current from VTT. The disadvantage of this circuit is that the maximum continuous current is reduced because of the lower rail voltage, although it is adequate for all motherboard SSTL-2 applications. Increasing the output capacitance can also help if periods of large load transients are encountered.

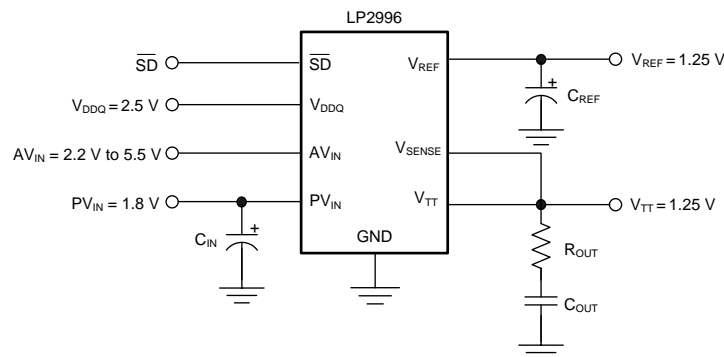

Copyright © 2016, Texas Instruments Incorporated

Figure 23. Lower Power Dissipation SSTL-2 Implementation

The third option for SSTL-2 applications in the situation that a 1.8-V rail is not available and it is not desirable to use 2.5 V, is to connect the LP2996-N or LP2996A power rail to 3.3 V. In this situation AVIN is limited to operation on the 3.3-V or 5-V rail as PVIN can never exceed AVIN. This configuration has the ability to provide the maximum continuous output current at the downside of higher thermal dissipation. Prevent the device from experiencing large current levels which cause the junction temperature to exceed the maximum. Because of this risk, TI recommends not supplying the output stage with a voltage higher than a nominal 3.3-V rail.

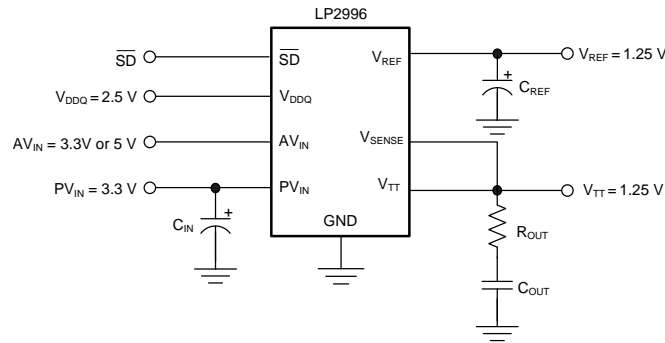

Copyright © 2016, Texas Instruments Incorporated

Figure 24. SSTL-2 Implementation with Higher Voltage Rails

8.2.2.2 DDR-II Applications

With the separate VDDQ pin and an internal resistor divider it is possible to use the LP2996-N and LP2996A in applications utilizing DDR-II memory. Figure 25 and Figure 26 show implementations of recommended circuit configurations for DDR-II applications. The output stage is connected to the 1.8-V rail and the AVIN pin can be connected to either a 3.3-V or 5-V rail. TI recommends the LP2996A, LP2998, or LP2998-Q1 for DDR-III and DDR-III low power designs.

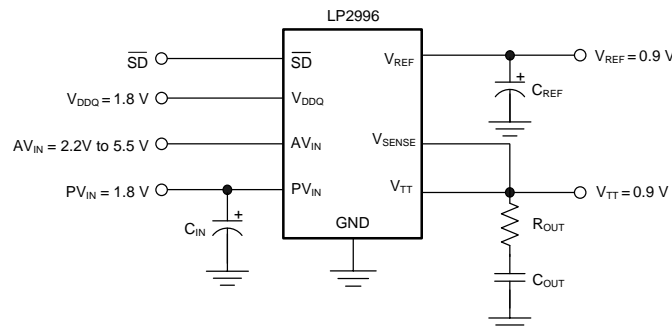

Copyright © 2016, Texas Instruments Incorporated

Figure 25. Recommended DDR-II Termination

If it is not desirable to use the 1.8-V rail it is possible to connect the output stage to a 3.3-V rail. Take care not to exceed the maximum junction temperature as the thermal dissipation increases with lower VTT output voltages. For this reason, TI does not recommend powering PVIN from a rail higher than the nominal 3.3 V. The advantage of this configuration is that it has the ability to source and sink a higher maximum continuous current.

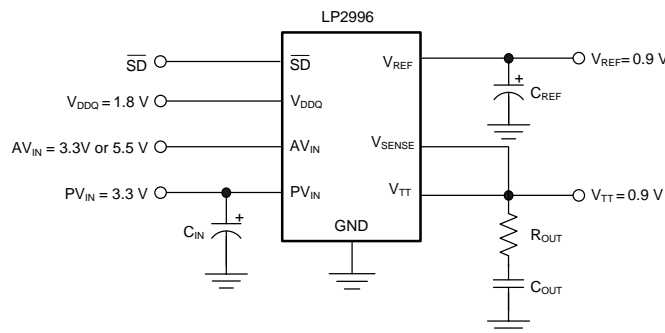

Copyright © 2016, Texas Instruments Incorporated

Figure 26. DDR-II Termination with Higher Voltage Rails

8.2.2.3 DDR-III Applications

With the separate VDDQ pin and an internal resistor divider it is possible to use the LP2996A in applications utilizing DDR-III memory. The output stage is connected to the 1.5-V rail and the AVIN pin can be connected to a 2.2-V to 5.5-V rail.

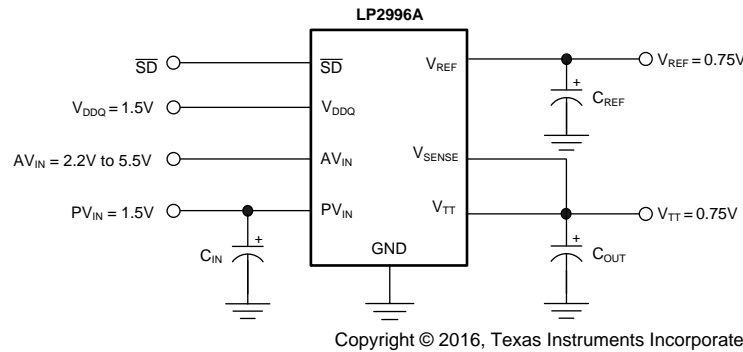

Figure 27. Recommended DDR-III Termination Using the LP2996A

If it is not desirable to use the 1.5-V to 2.5-V rail it is possible to connect the output stage to a 3.3-V rail. Do not exceed the maximum junction temperature as the thermal dissipation increases with lower V_{TT} output voltages. For this reason, TI recommends not to power PVIN off a rail higher than the nominal 3.3-V. The advantage of this configuration is that it has the ability to source and sink a higher maximum continuous current.

8.2.3 Level Shifting

If standards other than SSTL-2 are required, such as SSTL-3, it may be necessary to use a different scaling factor than V_{DDQ} / 2 for regulating the output voltage. Several options are available to scale the output to any voltage required. One method is to level shift the output by using feedback resistors from V_{TT} to the VSENSE pin. This is shown in Figure 28 and Figure 29. Figure 28 shows how to use two resistors to level shift V_{TT} above the internal reference voltage of V_{DDQ} / 2. Calculate the exact voltage at V_{TT} with Equation 1.

$$V_{TT} = \frac{V_{DDQ}}{2} \times \left(1 + \frac{R1}{R2} \right) \tag{1}$$

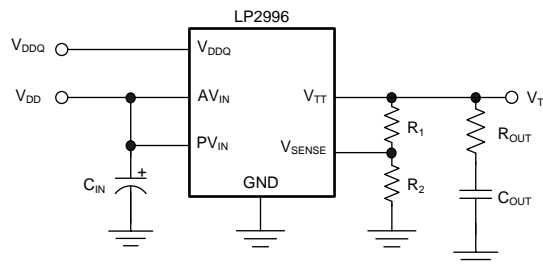
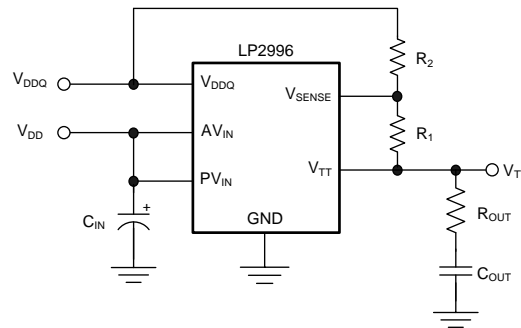

Figure 28. Increasing V_{TT} by Level Shifting

Conversely, the R2 resistor can be placed between VSENSE and VDDQ to shift the V_{TT} output lower than the internal reference voltage of V_{DDQ} / 2. Equation 2 shows the relation of V_{TT} to the resistors.

$$V_{TT} = \frac{V_{DDQ}}{2} \times \left(1 - \frac{R1}{R2} \right) \tag{2}$$



Copyright © 2016, Texas Instruments Incorporated

Figure 29. Decreasing V_{TT} by Level Shifting

8.2.4 HSTL Applications

The LP2996-N and LP2996A can be easily adapted for HSTL applications by connecting VDDQ to the 1.5-V rail. This produces a VTT and VREF voltage of approximately 0.75 V for the termination resistors. AVIN and PVIN must be connected to a 2.5-V rail for optimal performance.

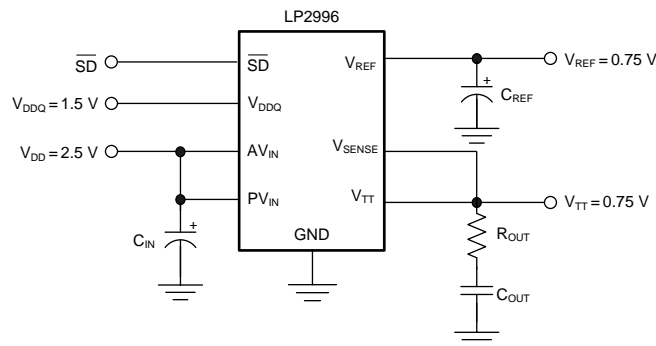

Copyright © 2016, Texas Instruments Incorporated

Figure 30. HSTL Application

8.2.5 QDR Applications

Quad data rate (QDR) applications use multiple channels for improved memory performance. However, this increase in bus lines increases the current levels required for termination. TI recommends using a dedicated LP2996-N or LP2996A for each channel to terminate multiple channels. This simplifies layout and reduces the internal power dissipation for each regulator. Separate VREF signals can be used for each DIMM bank from the corresponding regulator with the chipset reference provided by a local resistor divider or one of the LP2996-N or LP2996A signals. Because V_{REF} and V_{TT} are expected to track and the part to part variations are minor, there must be little difference between the reference signals of each device.

9 Power Supply Recommendations

There are several recommendations for the LP2996-N and LP2996A input power supply. Although not required, TI recommends an input capacitor for improved performance during large load transients to prevent the input rail from dropping. The input capacitor must be placed as close as possible to the PVIN pin.

A typical value recommended for aluminum electrolytic capacitors is 50 μ F. Ceramic capacitors can also be used, a value approximately 10 μ F with X5R or better would be an ideal choice. The input capacitance can be reduced if the LP2996-N or LP2996A is placed close to the bulk capacitance from the output of the 2.5-V DC-DC converter. If the two supply rails (AVIN and PVIN) are separated then the 47- μ F capacitor must be placed as close to possible to the PVIN rail. An additional 0.1- μ F ceramic capacitor can be placed on the AVIN rail to prevent excessive noise from coupling into the device.

10.3 Thermal Considerations

Because the LP2996-N and LP2996A are linear regulators, any current flow from VTT results in internal power dissipation generating heat. To prevent damaging the part from exceeding the maximum allowable junction temperature, derate the part according to the maximum expected ambient temperature and power dissipation. The maximum allowable internal temperature rise ($T_{R(MAX)}$) can be calculated with Equation 3 given the maximum ambient temperature ($T_{A(MAX)}$) of the application and the maximum allowable junction temperature ($T_{J(MAX)}$).

$$T_{R(MAX)} = T_{J(MAX)} - T_{A(MAX)} \quad (3)$$

From this equation, the maximum power dissipation ($P_{D(MAX)}$) of the part can be calculated with Equation 4.

$$P_{D(MAX)} = T_{R(MAX)} / R_{\theta JA} \quad (4)$$

The $R_{\theta JA}$ of the LP2996-N and LP2996A is dependent on several variables: the package used; the thickness of copper; the number of vias and the airflow. For instance, the $R_{\theta JA}$ of the SOIC is 163°C/W with the package mounted to a standard 8×4 2-layer board with 1-oz copper, no airflow, and 0.5-W dissipation at room temperature. This value can be reduced to 151.2°C/W by changing to a 3×4 board with 2-oz copper that is the JEDEC standard. Figure 33 shows how the $R_{\theta JA}$ varies with airflow for the two boards mentioned.

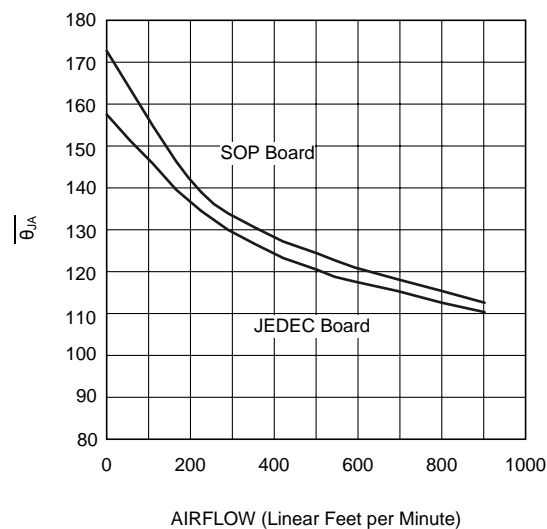
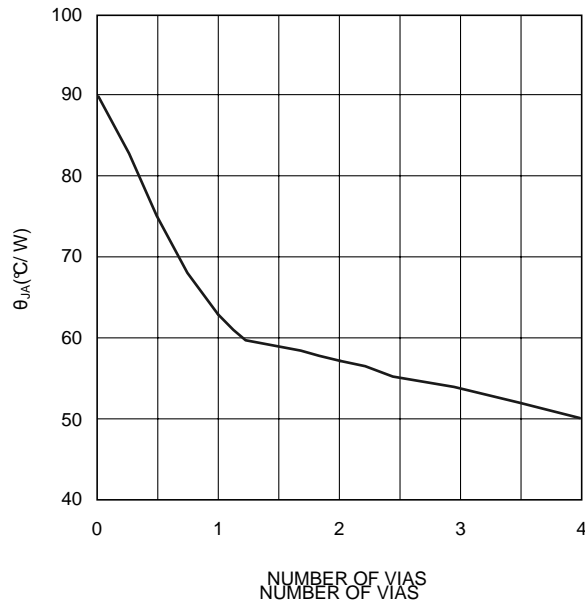

Figure 33. $R_{\theta JA}$ vs Airflow (SOIC)

Additional improvements can be made by the judicious use of vias to connect the part and dissipate heat to an internal ground plane. Using larger traces and more copper on the top side of the board can also help. With careful layout, it is possible to reduce the $R_{\theta JA}$ further than the nominal values shown in Figure 33

Layout is also extremely critical to maximize the output current with the WQFN package. By simply placing vias under the thermal pad, the $R_{\theta JA}$ can be lowered significantly. Figure 34 shows the WQFN thermal data when placed on a 4-layer JEDEC board with copper thickness of 0.5 oz, 1 oz, 1 oz, and 0.5 oz (respectively). The number of vias with a pitch of 1.27 mm is increased to the maximum of 4, where a $R_{\theta JA}$ of 50.41°C/W can be obtained. Via wall thickness for this calculation is 0.036 mm for 1-oz copper.

Thermal Considerations (continued)



4-layer JEDEC board

Figure 34. WQFN-16 $R_{\theta JA}$ vs Number of Vias

Additional improvements in lowering the $R_{\theta JA}$ can be achieved with a constant airflow across the package. Maintaining the same conditions as above and utilizing the 2x2 via array, Figure 35 shows how the $R_{\theta JA}$ varies with airflow.

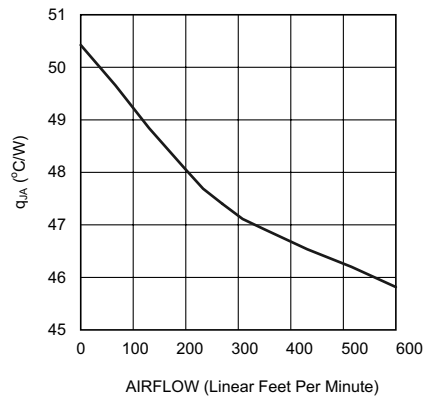

JEDEC board with 4 vias

Figure 35. $R_{\theta JA}$ vs Airflow Speed

Thermal Considerations (continued)

Optimizing the $R_{\theta JA}$ and placing the device in a section of a board exposed to lower ambient temperature allows the part to operate with higher power dissipation. The internal power dissipation can be calculated by summing the three main sources of loss: output current at VTT, either sinking or sourcing, and quiescent current at AVIN and VDDQ. During the active state, when the shutdown pin (SD) is not held low, the total internal power dissipation can be calculated with [Equation 5](#).

$$P_D = P_{AVIN} + P_{VDDQ} + P_{VTT}$$

where

- $P_{AVIN} = I_{AVIN} \times V_{AVIN}$
- $P_{VDDQ} = V_{VDDQ} \times I_{VDDQ} = V_{VDDQ2} \times R_{VDDQ}$ (5)

To calculate the maximum power dissipation at VTT both conditions (sinking and sourcing current) at VTT must be examined. Although only one equation is added into the total, because VTT cannot source and sink current simultaneously.

Calculate sinking with [Equation 6](#).

$$P_{VTT} = V_{VTT} \times I_{LOAD} \quad (6)$$

Or calculate sourcing with [Equation 7](#).

$$P_{VTT} = (V_{PVIN} - V_{VTT}) \times I_{LOAD} \quad (7)$$

The power dissipation of the LP2996-N and LP2996A can also be calculated during the shutdown state. During this condition the output (VTT) is tri-stated; Therefore, that term in the power equation disappears as it cannot sink or source any current, and leakage is negligible. The only losses during shutdown are the reduced quiescent current at AVIN and the constant impedance that is seen at the VDDQ pin.

$$P_D = P_{AVIN} + P_{VDDQ}$$

where

- $P_{AVIN} = I_{AVIN} \times V_{AVIN}$
- $P_{VDDQ} = V_{VDDQ} \times I_{VDDQ} = V_{VDDQ2} \times R_{VDDQ}$ (8)

11 デバイスおよびドキュメントのサポート

11.1 ドキュメントのサポート

11.1.1 関連資料

関連資料については、以下を参照してください。

『[DDR終端レギュレータの突入電流の制限](#)』(SNVA758)

11.2 関連リンク

次の表に、クイック・アクセス・リンクを示します。カテゴリには、技術資料、サポートおよびコミュニティ・リソース、ツールとソフトウェア、およびサンプル注文またはご購入へのクイック・アクセスが含まれます。

表 3. 関連リンク

製品	プロダクト・フォルダ	サンプルとご購入	技術資料	ツールとソフトウェア	サポートとコミュニティ
LP2996-N	ここをクリック	ここをクリック	ここをクリック	ここをクリック	ここをクリック
LP2996A	ここをクリック	ここをクリック	ここをクリック	ここをクリック	ここをクリック

11.3 ドキュメントの更新通知を受け取る方法

ドキュメントの更新についての通知を受け取るには、[ti.com](#)のデバイス製品フォルダを開いてください。右上の隅にある「通知を受け取る」をクリックして登録すると、変更されたすべての製品情報に関するダイジェストを毎週受け取れます。変更の詳細については、修正されたドキュメントに含まれている改訂履歴をご覧ください。

11.4 コミュニティ・リソース

The following links connect to TI community resources. Linked contents are provided "AS IS" by the respective contributors. They do not constitute TI specifications and do not necessarily reflect TI's views; see TI's [Terms of Use](#).

TI E2E™オンライン・コミュニティ *TIのE2E (Engineer-to-Engineer) コミュニティ*。エンジニア間の共同作業を促進するために開設されたものです。e2e.ti.comでは、他のエンジニアに質問し、知識を共有し、アイデアを検討して、問題解決に役立てることができます。

設計サポート *TIの設計サポート* 役に立つE2Eフォーラムや、設計サポート・ツールをすばやく見つけることができます。技術サポート用の連絡先情報も参照できます。

11.5 商標

E2E is a trademark of Texas Instruments.

WEBENCH is a registered trademark of Texas Instruments.

All other trademarks are the property of their respective owners.

11.6 静電気放電に関する注意事項



すべての集積回路は、適切なESD保護方法を用いて、取扱いと保存を行うようにして下さい。

静電気放電はわずかな性能の低下から完全なデバイスの故障に至るまで、様々な損傷を与えます。高精度の集積回路は、損傷に対して敏感であり、極めてわずかなパラメータの変化により、デバイスに規定された仕様に適合しなくなる場合があります。

11.7 用語集

SLYZ022 — *TI用語集*。

この用語集には、用語や略語の一覧および定義が記載されています。

12 メカニカル、パッケージ、および注文情報

以降のページには、メカニカル、パッケージ、および注文に関する情報が記載されています。この情報は、そのデバイスについて利用可能な最新のデータです。このデータは予告なく変更されることがあり、ドキュメントが改訂される場合もあります。本データシートのブラウザ版を使用されている場合は、画面左側の説明をご覧ください。

PACKAGING INFORMATION

Orderable part number	Status (1)	Material type (2)	Package Pins	Package qty Carrier	RoHS (3)	Lead finish/ Ball material (4)	MSL rating/ Peak reflow (5)	Op temp (°C)	Part marking (6)
LP2996AMR/NOPB	Active	Production	SO PowerPAD (DDA) 8	95 TUBE	Yes	FULL NIPDAU SN	Level-3-260C-168 HR	0 to 125	LP2996 AMR
LP2996AMR/NOPB.A	Active	Production	SO PowerPAD (DDA) 8	95 TUBE	Yes	FULL NIPDAU	Level-3-260C-168 HR	0 to 125	LP2996 AMR
LP2996AMRE/NOPB	Active	Production	SO PowerPAD (DDA) 8	250 SMALL T&R	Yes	FULL NIPDAU SN	Level-3-260C-168 HR	0 to 125	LP2996 AMR
LP2996AMRE/NOPB.A	Active	Production	SO PowerPAD (DDA) 8	250 SMALL T&R	Yes	FULL NIPDAU	Level-3-260C-168 HR	0 to 125	LP2996 AMR
LP2996AMRX/NOPB	Active	Production	SO PowerPAD (DDA) 8	2500 LARGE T&R	Yes	FULL NIPDAU SN	Level-3-260C-168 HR	0 to 125	LP2996 AMR
LP2996AMRX/NOPB.A	Active	Production	SO PowerPAD (DDA) 8	2500 LARGE T&R	Yes	FULL NIPDAU	Level-3-260C-168 HR	0 to 125	LP2996 AMR
LP2996LQ/NOPB	Active	Production	WQFN (NHP) 16	1000 SMALL T&R	Yes	SN	Level-3-260C-168 HR	0 to 125	L00006B
LP2996LQ/NOPB.A	Active	Production	WQFN (NHP) 16	1000 SMALL T&R	Yes	SN	Level-3-260C-168 HR	0 to 125	L00006B
LP2996M/NOPB	Active	Production	SOIC (D) 8	95 TUBE	Yes	SN	Level-1-260C-UNLIM	0 to 125	2996M
LP2996M/NOPB.A	Active	Production	SOIC (D) 8	95 TUBE	Yes	SN	Level-1-260C-UNLIM	0 to 125	2996M
LP2996MR/NOPB	Active	Production	SO PowerPAD (DDA) 8	95 TUBE	Yes	FULL NIPDAU SN	Level-3-260C-168 HR	0 to 125	LP2996
LP2996MR/NOPB.A	Active	Production	SO PowerPAD (DDA) 8	95 TUBE	Yes	FULL NIPDAU	Level-3-260C-168 HR	0 to 125	LP2996
LP2996MRX/NOPB	Active	Production	SO PowerPAD (DDA) 8	2500 LARGE T&R	Yes	FULL NIPDAU SN	Level-3-260C-168 HR	0 to 125	LP2996
LP2996MRX/NOPB.A	Active	Production	SO PowerPAD (DDA) 8	2500 LARGE T&R	Yes	FULL NIPDAU	Level-3-260C-168 HR	0 to 125	LP2996
LP2996MRX/NOPBG4.A	Active	Production	SO PowerPAD (DDA) 8	2500 LARGE T&R	-	Call TI	Call TI	0 to 125	
LP2996MX/NOPB	Active	Production	SOIC (D) 8	2500 LARGE T&R	Yes	SN	Level-1-260C-UNLIM	0 to 125	2996M
LP2996MX/NOPB.A	Active	Production	SOIC (D) 8	2500 LARGE T&R	Yes	SN	Level-1-260C-UNLIM	0 to 125	2996M

(1) **Status:** For more details on status, see our [product life cycle](#).

- (2) **Material type:** When designated, preproduction parts are prototypes/experimental devices, and are not yet approved or released for full production. Testing and final process, including without limitation quality assurance, reliability performance testing, and/or process qualification, may not yet be complete, and this item is subject to further changes or possible discontinuation. If available for ordering, purchases will be subject to an additional waiver at checkout, and are intended for early internal evaluation purposes only. These items are sold without warranties of any kind.
- (3) **RoHS values:** Yes, No, RoHS Exempt. See the [TI RoHS Statement](#) for additional information and value definition.
- (4) **Lead finish/Ball material:** Parts may have multiple material finish options. Finish options are separated by a vertical ruled line. Lead finish/Ball material values may wrap to two lines if the finish value exceeds the maximum column width.
- (5) **MSL rating/Peak reflow:** The moisture sensitivity level ratings and peak solder (reflow) temperatures. In the event that a part has multiple moisture sensitivity ratings, only the lowest level per JEDEC standards is shown. Refer to the shipping label for the actual reflow temperature that will be used to mount the part to the printed circuit board.
- (6) **Part marking:** There may be an additional marking, which relates to the logo, the lot trace code information, or the environmental category of the part.

Multiple part markings will be inside parentheses. Only one part marking contained in parentheses and separated by a "~" will appear on a part. If a line is indented then it is a continuation of the previous line and the two combined represent the entire part marking for that device.

Important Information and Disclaimer: The information provided on this page represents TI's knowledge and belief as of the date that it is provided. TI bases its knowledge and belief on information provided by third parties, and makes no representation or warranty as to the accuracy of such information. Efforts are underway to better integrate information from third parties. TI has taken and continues to take reasonable steps to provide representative and accurate information but may not have conducted destructive testing or chemical analysis on incoming materials and chemicals. TI and TI suppliers consider certain information to be proprietary, and thus CAS numbers and other limited information may not be available for release.

In no event shall TI's liability arising out of such information exceed the total purchase price of the TI part(s) at issue in this document sold by TI to Customer on an annual basis.

TAPE AND REEL INFORMATION

QUADRANT ASSIGNMENTS FOR PIN 1 ORIENTATION IN TAPE



*All dimensions are nominal

Device	Package Type	Package Drawing	Pins	SPQ	Reel Diameter (mm)	Reel Width W1 (mm)	A0 (mm)	B0 (mm)	K0 (mm)	P1 (mm)	W (mm)	Pin1 Quadrant
LP2996AMRE/NOPB	SO PowerPAD	DDA	8	250	330.0	12.5	6.4	5.2	2.1	8.0	12.0	Q1
LP2996AMRE/NOPB	SO PowerPAD	DDA	8	250	177.8	12.4	6.5	5.4	2.0	8.0	12.0	Q1
LP2996AMRX/NOPB	SO PowerPAD	DDA	8	2500	330.0	12.4	6.5	5.4	2.0	8.0	12.0	Q1
LP2996AMRX/NOPB	SO PowerPAD	DDA	8	2500	330.0	12.5	6.4	5.2	2.1	8.0	12.0	Q1
LP2996LQ/NOPB	WQFN	NHP	16	1000	177.8	12.4	4.3	4.3	1.3	8.0	12.0	Q1
LP2996MRX/NOPB	SO PowerPAD	DDA	8	2500	330.0	12.5	6.4	5.2	2.1	8.0	12.0	Q1
LP2996MRX/NOPB	SO PowerPAD	DDA	8	2500	330.0	12.4	6.5	5.4	2.0	8.0	12.0	Q1
LP2996MX/NOPB	SOIC	D	8	2500	330.0	12.4	6.5	5.4	2.0	8.0	12.0	Q1

TAPE AND REEL BOX DIMENSIONS

*All dimensions are nominal

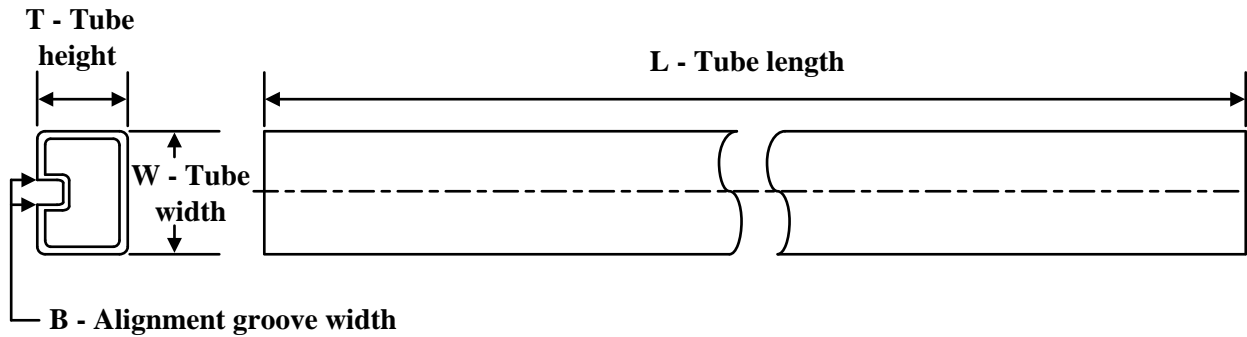
Device	Package Type	Package Drawing	Pins	SPQ	Length (mm)	Width (mm)	Height (mm)
LP2996AMRE/NOPB	SO PowerPAD	DDA	8	250	340.5	338.1	20.6
LP2996AMRE/NOPB	SO PowerPAD	DDA	8	250	208.0	191.0	35.0
LP2996AMRX/NOPB	SO PowerPAD	DDA	8	2500	356.0	356.0	36.0
LP2996AMRX/NOPB	SO PowerPAD	DDA	8	2500	340.5	338.1	20.6
LP2996LQ/NOPB	WQFN	NHP	16	1000	208.0	191.0	35.0
LP2996MRX/NOPB	SO PowerPAD	DDA	8	2500	353.0	353.0	32.0
LP2996MRX/NOPB	SO PowerPAD	DDA	8	2500	356.0	356.0	36.0
LP2996MX/NOPB	SOIC	D	8	2500	367.0	367.0	35.0

TUBE

*All dimensions are nominal

Device	Package Name	Package Type	Pins	SPQ	L (mm)	W (mm)	T (μm)	B (mm)
LP2996AMR/NOPB	DDA	HSOIC	8	95	495	8	4064	3.05
LP2996AMR/NOPB	DDA	HSOIC	8	95	507.79	8	630	4.32
LP2996AMR/NOPB.A	DDA	HSOIC	8	95	495	8	4064	3.05
LP2996AMR/NOPB.A	DDA	HSOIC	8	95	507.79	8	630	4.32
LP2996M/NOPB	D	SOIC	8	95	495	8	4064	3.05
LP2996M/NOPB.A	D	SOIC	8	95	495	8	4064	3.05
LP2996MR/NOPB	DDA	HSOIC	8	95	495	8	4064	3.05
LP2996MR/NOPB	DDA	HSOIC	8	95	495	8	4064	3.05
LP2996MR/NOPB	DDA	HSOIC	8	95	507.79	8	630	4.32
LP2996MR/NOPB.A	DDA	HSOIC	8	95	495	8	4064	3.05
LP2996MR/NOPB.A	DDA	HSOIC	8	95	507.79	8	630	4.32
LP2996MR/NOPB.A	DDA	HSOIC	8	95	495	8	4064	3.05

DDA0008A

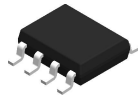

PACKAGE OUTLINE

PowerPAD™ SOIC - 1.7 mm max height

PLASTIC SMALL OUTLINE

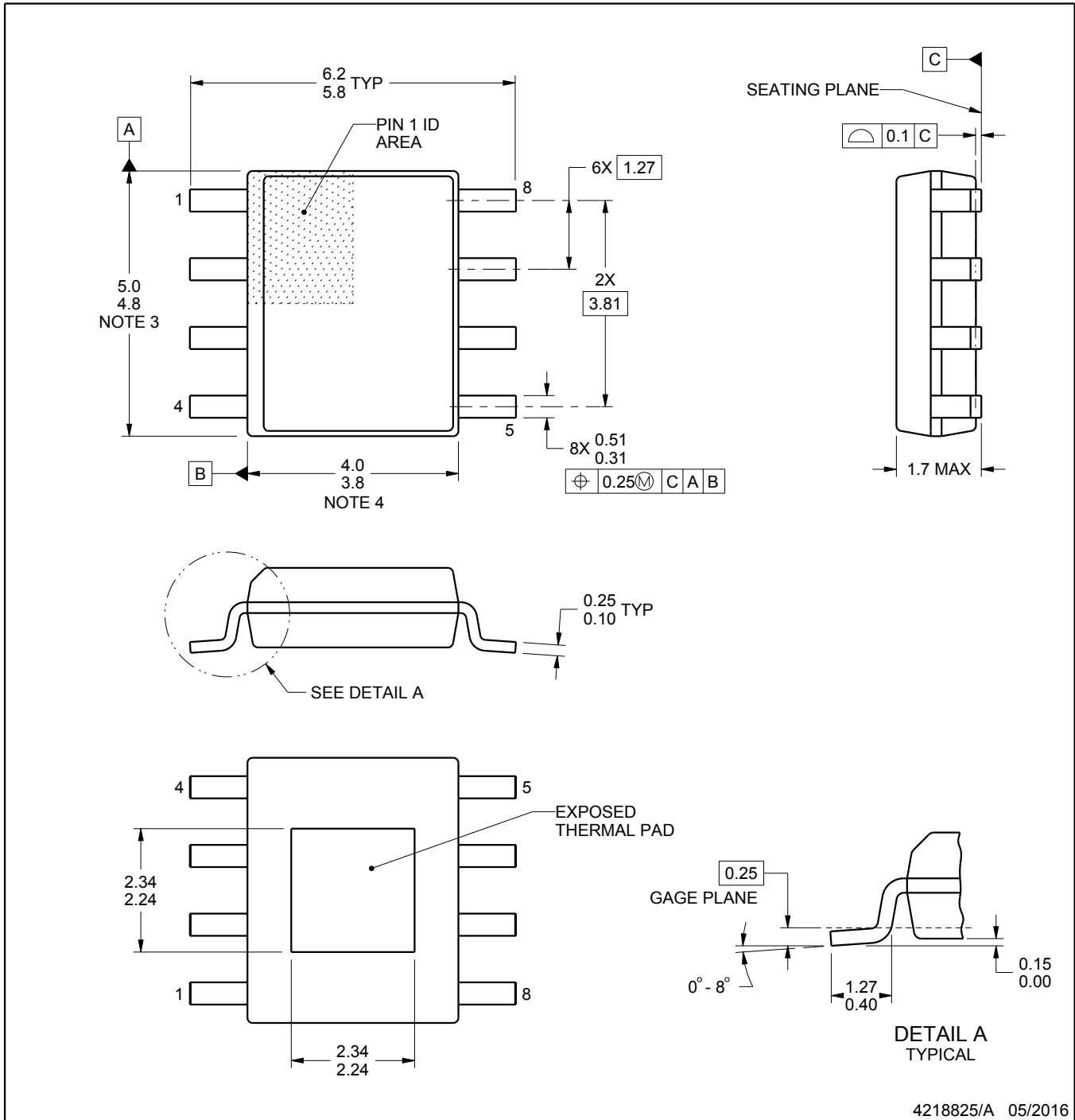

4218825/A 05/2016

PowerPAD is a trademark of Texas Instruments.

NOTES:

1. All linear dimensions are in millimeters. Any dimensions in parenthesis are for reference only. Dimensioning and tolerancing per ASME Y14.5M.
2. This drawing is subject to change without notice.
3. This dimension does not include mold flash, protrusions, or gate burrs. Mold flash, protrusions, or gate burrs shall not exceed 0.15 mm per side.
4. This dimension does not include interlead flash. Interlead flash shall not exceed 0.25 mm per side.
5. Reference JEDEC registration MS-012.

EXAMPLE BOARD LAYOUT

DDA0008A

PowerPAD™ SOIC - 1.7 mm max height

PLASTIC SMALL OUTLINE

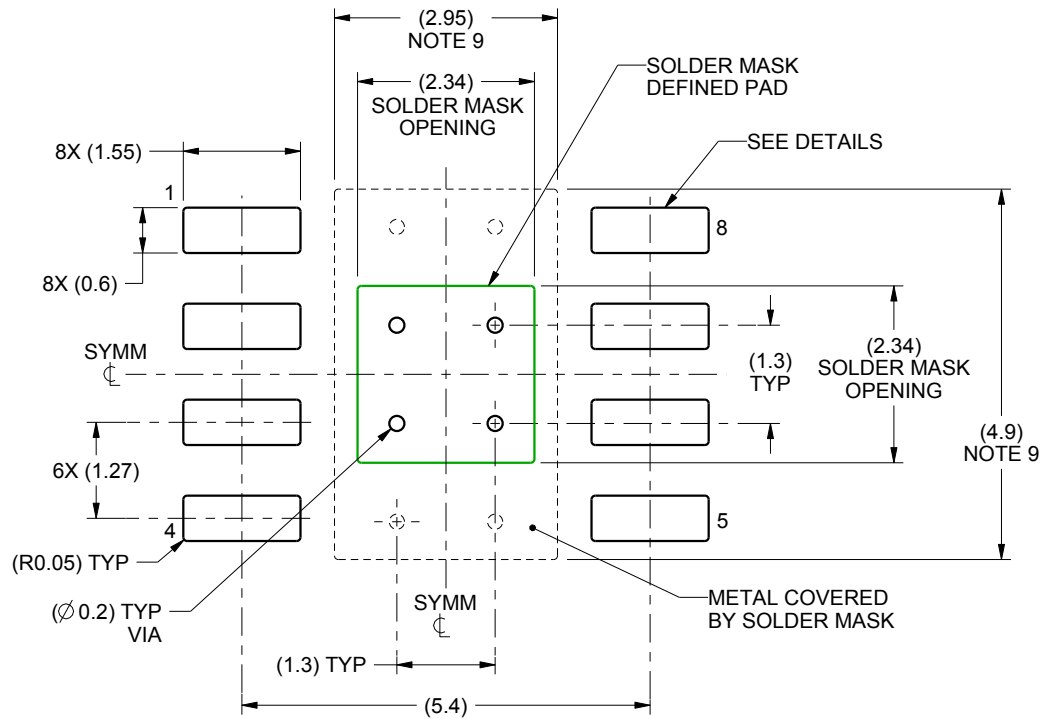

LAND PATTERN EXAMPLE
SCALE:10X

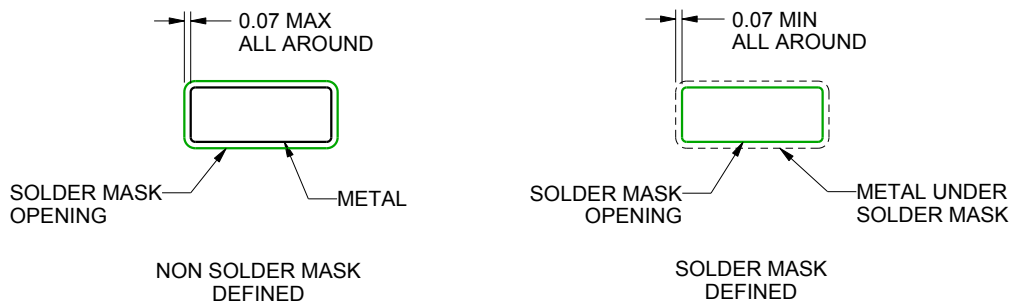

SOLDER MASK DETAILS

4218825/A 05/2016

NOTES: (continued)

6. Publication IPC-7351 may have alternate designs.
7. Solder mask tolerances between and around signal pads can vary based on board fabrication site.
8. This package is designed to be soldered to a thermal pad on the board. For more information, see Texas Instruments literature numbers SLMA002 (www.ti.com/lit/slma002) and SLMA004 (www.ti.com/lit/slma004).
9. Size of metal pad may vary due to creepage requirement.
10. Vias are optional depending on application, refer to device data sheet. If any vias are implemented, refer to their locations shown on this view. It is recommended that vias under paste be filled, plugged or tented.

EXAMPLE STENCIL DESIGN

DDA0008A

PowerPAD™ SOIC - 1.7 mm max height

PLASTIC SMALL OUTLINE

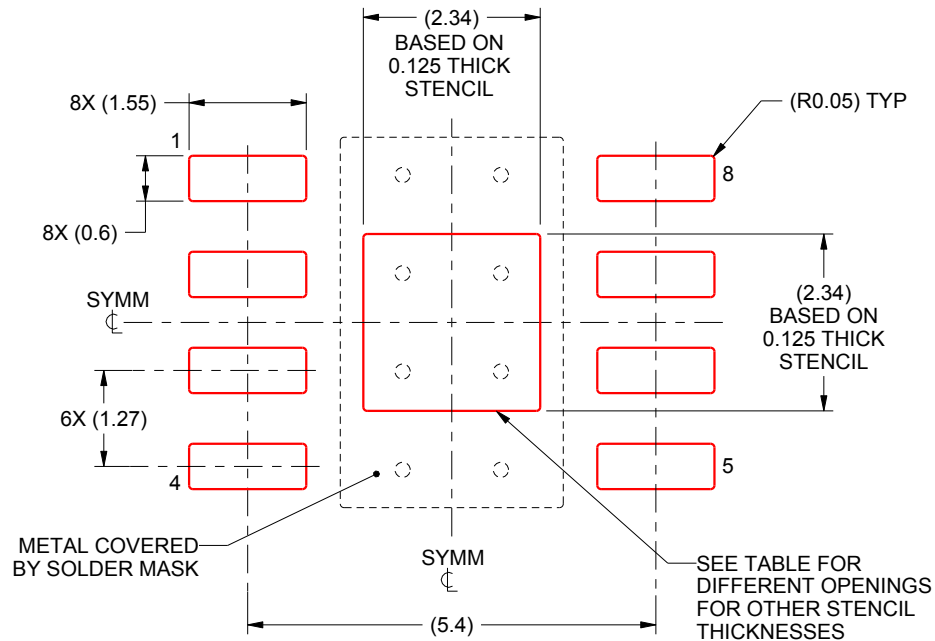

SOLDER PASTE EXAMPLE
 EXPOSED PAD
 100% PRINTED SOLDER COVERAGE BY AREA
 SCALE:10X

STENCIL THICKNESS	SOLDER STENCIL OPENING
0.1	2.62 X 2.62
0.125	2.34 X 2.34 (SHOWN)
0.150	2.14 X 2.14
0.175	1.98 X 1.98

4218825/A 05/2016

NOTES: (continued)

11. Laser cutting apertures with trapezoidal walls and rounded corners may offer better paste release. IPC-7525 may have alternate design recommendations.
12. Board assembly site may have different recommendations for stencil design.

DDA0008D



PACKAGE OUTLINE

PowerPAD™ SOIC - 1.7 mm max height

PLASTIC SMALL OUTLINE

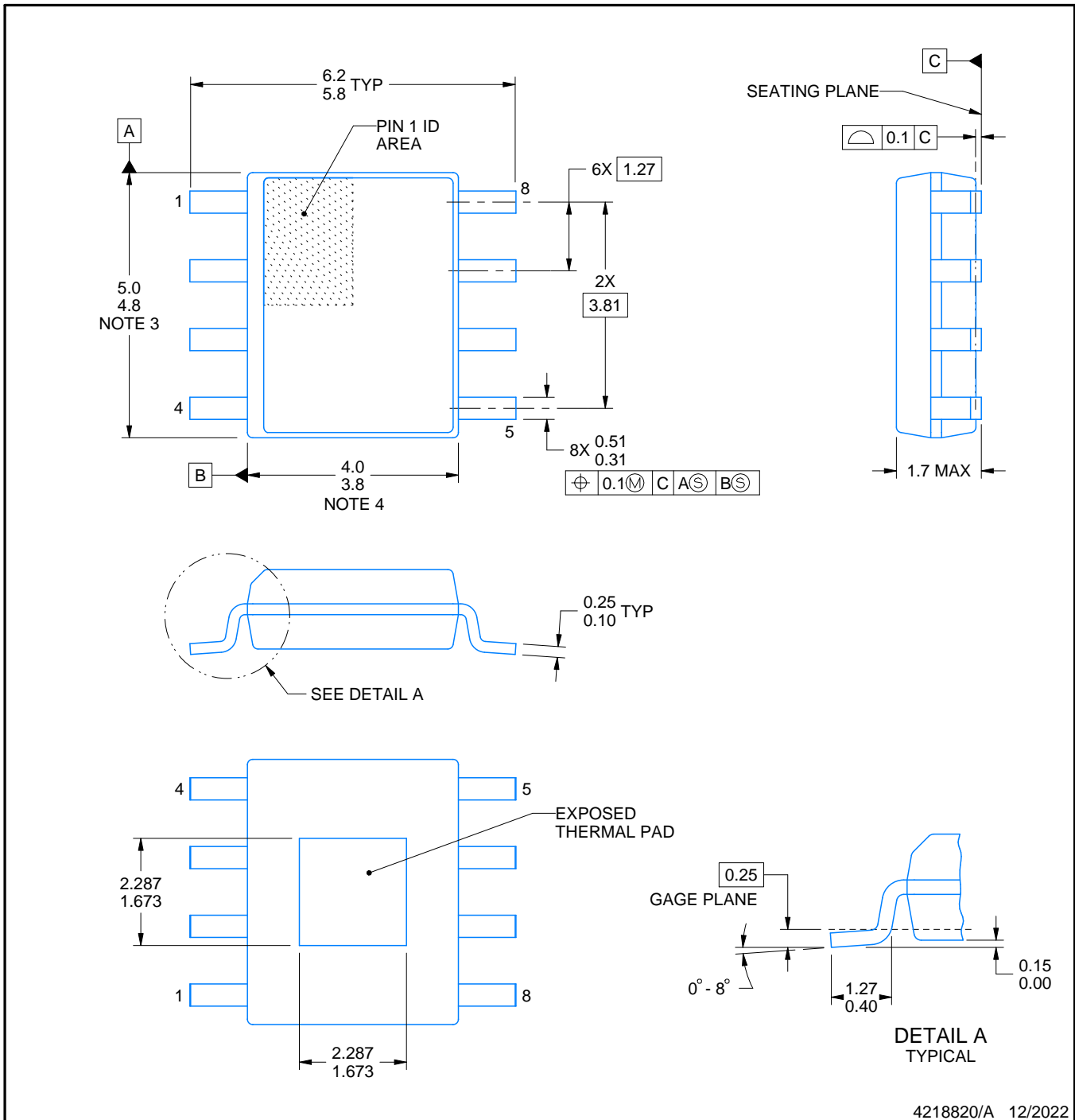

4218820/A 12/2022

PowerPAD is a trademark of Texas Instruments.

NOTES:

1. All linear dimensions are in millimeters. Any dimensions in parenthesis are for reference only. Dimensioning and tolerancing per ASME Y14.5M.
2. This drawing is subject to change without notice.
3. This dimension does not include mold flash, protrusions, or gate burrs. Mold flash, protrusions, or gate burrs shall not exceed 0.15 mm per side.
4. This dimension does not include interlead flash. Interlead flash shall not exceed 0.25 mm per side.
5. Reference JEDEC registration MS-012, variation BA.

EXAMPLE BOARD LAYOUT

DDA0008D

PowerPAD™ SOIC - 1.7 mm max height

PLASTIC SMALL OUTLINE

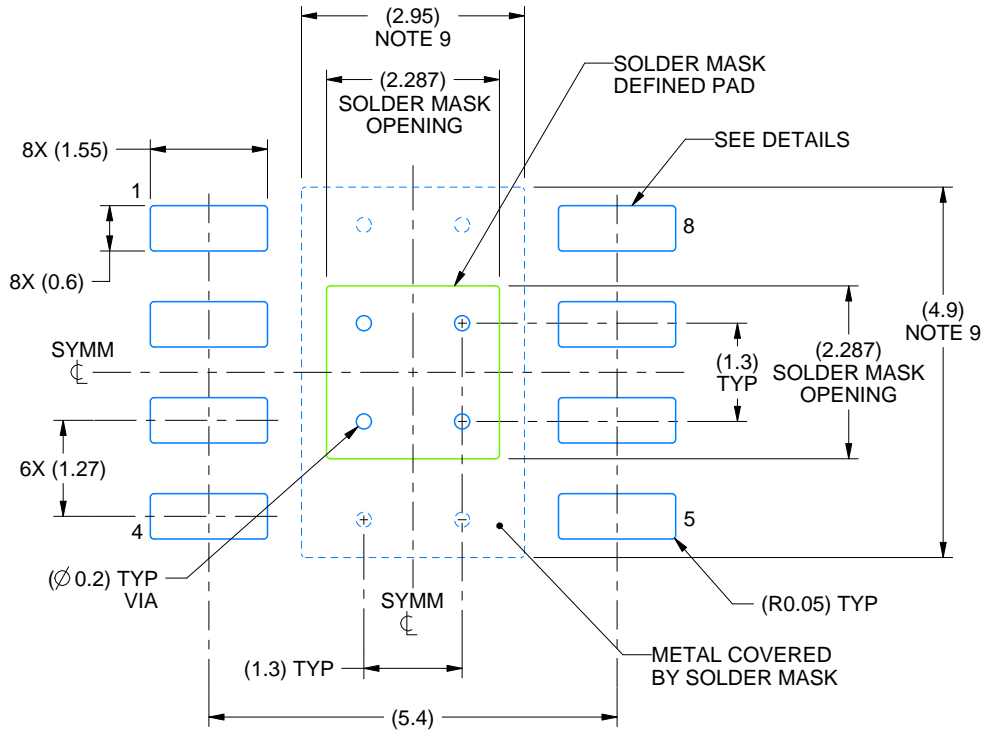

LAND PATTERN EXAMPLE
SCALE:10X

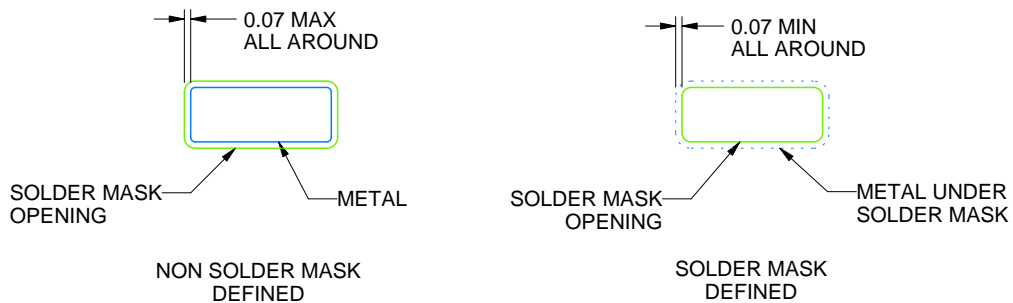

SOLDER MASK DETAILS

4218820/A 12/2022

NOTES: (continued)

6. Publication IPC-7351 may have alternate designs.
7. Solder mask tolerances between and around signal pads can vary based on board fabrication site.
8. This package is designed to be soldered to a thermal pad on the board. For more information, see Texas Instruments literature numbers SLMA002 (www.ti.com/lit/slma002) and SLMA004 (www.ti.com/lit/slma004).
9. Size of metal pad may vary due to creepage requirement.

EXAMPLE STENCIL DESIGN

DDA0008D

PowerPAD™ SOIC - 1.7 mm max height

PLASTIC SMALL OUTLINE

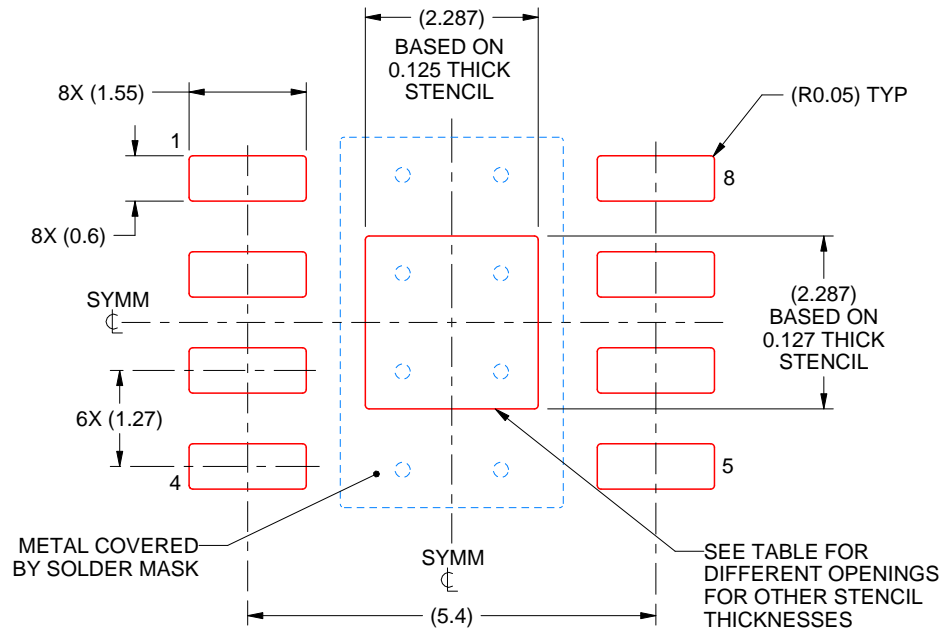

SOLDER PASTE EXAMPLE
EXPOSED PAD
100% PRINTED SOLDER COVERAGE BY AREA
SCALE:10X

STENCIL THICKNESS	SOLDER STENCIL OPENING
0.1	2.557 X 2.557
0.125	2.287 X 2.287 (SHOWN)
0.150	2.088 X 2.088
0.175	1.933 X 1.933

4218820/A 12/2022

NOTES: (continued)

10. Laser cutting apertures with trapezoidal walls and rounded corners may offer better paste release. IPC-7525 may have alternate design recommendations.
11. Board assembly site may have different recommendations for stencil design.

DDA0008B

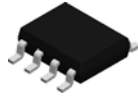

PACKAGE OUTLINE

PowerPAD™ SOIC - 1.7 mm max height

PLASTIC SMALL OUTLINE

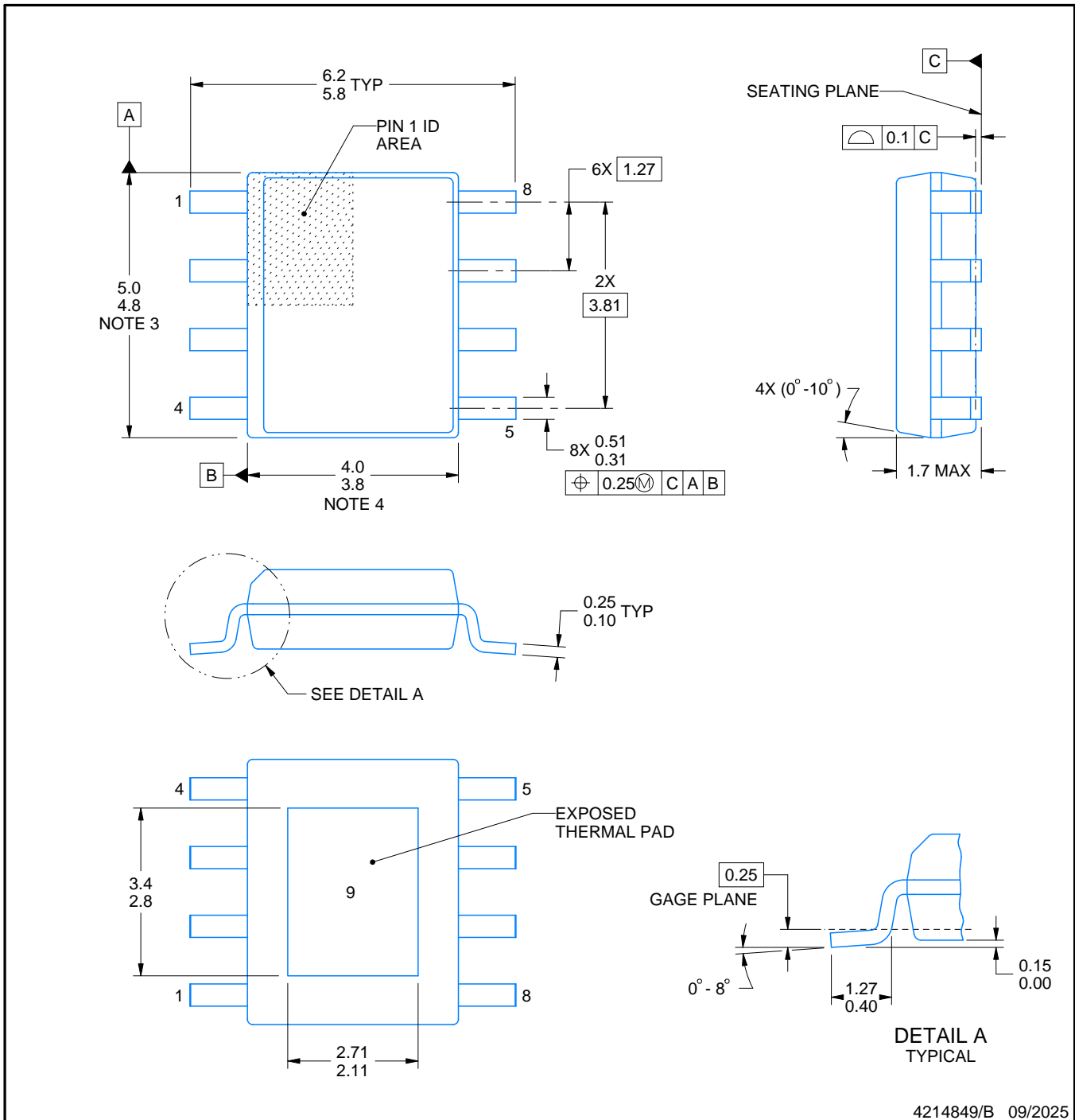

4214849/B 09/2025

NOTES:

PowerPAD is a trademark of Texas Instruments.

1. All linear dimensions are in millimeters. Any dimensions in parenthesis are for reference only. Dimensioning and tolerancing per ASME Y14.5M.
2. This drawing is subject to change without notice.
3. This dimension does not include mold flash, protrusions, or gate burrs. Mold flash, protrusions, or gate burrs shall not exceed 0.15 mm per side.
4. This dimension does not include interlead flash. Interlead flash shall not exceed 0.25 mm per side.
5. Reference JEDEC registration MS-012.

EXAMPLE STENCIL DESIGN

DDA0008B

PowerPAD™ SOIC - 1.7 mm max height

PLASTIC SMALL OUTLINE

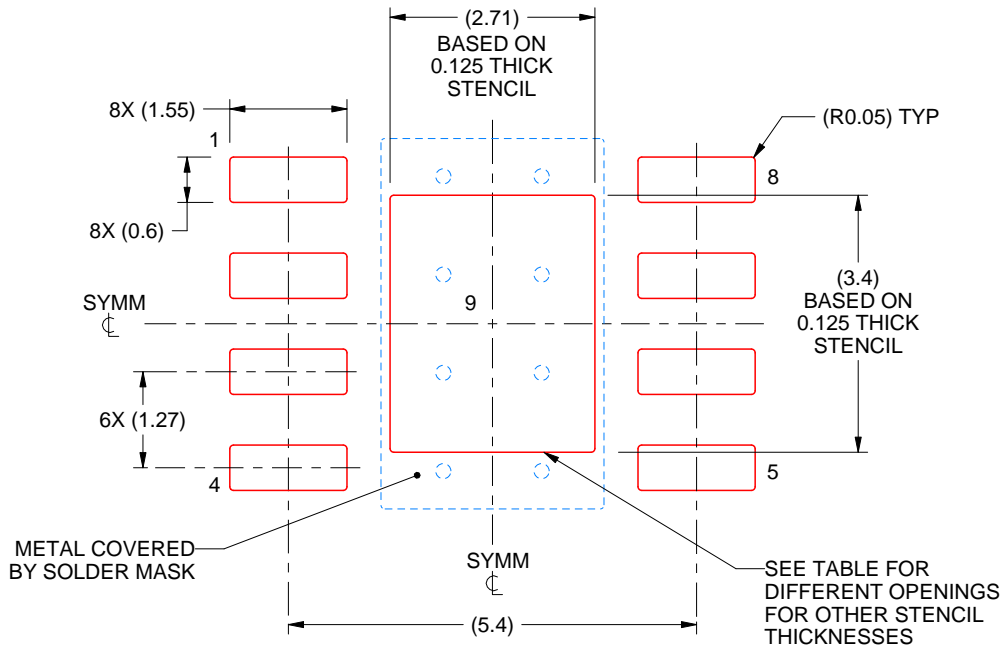

SOLDER PASTE EXAMPLE
EXPOSED PAD
100% PRINTED SOLDER COVERAGE BY AREA
SCALE:10X

STENCIL THICKNESS	SOLDER STENCIL OPENING
0.1	3.03 X 3.80
0.125	2.71 X 3.40 (SHOWN)
0.150	2.47 X 3.10
0.175	2.29 X 2.87

4214849/B 09/2025

NOTES: (continued)

11. Laser cutting apertures with trapezoidal walls and rounded corners may offer better paste release. IPC-7525 may have alternate design recommendations.
12. Board assembly site may have different recommendations for stencil design.



D0008A

PACKAGE OUTLINE

SOIC - 1.75 mm max height

SMALL OUTLINE INTEGRATED CIRCUIT



4214825/C 02/2019

NOTES:

- Linear dimensions are in inches [millimeters]. Dimensions in parenthesis are for reference only. Controlling dimensions are in inches. Dimensioning and tolerancing per ASME Y14.5M.
- This drawing is subject to change without notice.
- This dimension does not include mold flash, protrusions, or gate burrs. Mold flash, protrusions, or gate burrs shall not exceed $.006$ [0.15] per side.
- This dimension does not include interlead flash.
- Reference JEDEC registration MS-012, variation AA.

EXAMPLE BOARD LAYOUT

D0008A

SOIC - 1.75 mm max height

SMALL OUTLINE INTEGRATED CIRCUIT



LAND PATTERN EXAMPLE
 EXPOSED METAL SHOWN
 SCALE:8X



SOLDER MASK DETAILS

4214825/C 02/2019

NOTES: (continued)

- 6. Publication IPC-7351 may have alternate designs.
- 7. Solder mask tolerances between and around signal pads can vary based on board fabrication site.

EXAMPLE STENCIL DESIGN

D0008A

SOIC - 1.75 mm max height

SMALL OUTLINE INTEGRATED CIRCUIT



SOLDER PASTE EXAMPLE
BASED ON .005 INCH [0.125 MM] THICK STENCIL
SCALE:8X

4214825/C 02/2019

NOTES: (continued)

8. Laser cutting apertures with trapezoidal walls and rounded corners may offer better paste release. IPC-7525 may have alternate design recommendations.
9. Board assembly site may have different recommendations for stencil design.

重要なお知らせと免責事項

TI は、技術データと信頼性データ (データシートを含みます)、設計リソース (リファレンス デザインを含みます)、アプリケーションや設計に関する各種アドバイス、Web ツール、安全性情報、その他のリソースを、欠陥が存在する可能性のある「現状のまま」提供しており、商品性および特定目的に対する適合性の黙示保証、第三者の知的財産権の非侵害保証を含むいかなる保証も、明示的または黙示的にかかわらず拒否します。

これらのリソースは、TI 製品を使用する設計の経験を積んだ開発者への提供を意図したものです。(1) お客様のアプリケーションに適した TI 製品の選定、(2) お客様のアプリケーションの設計、検証、試験、(3) お客様のアプリケーションに該当する各種規格や、その他のあらゆる安全性、セキュリティ、規制、または他の要件への確実な適合に関する責任を、お客様のみが単独で負うものとし、

上記の各種リソースは、予告なく変更される可能性があります。これらのリソースは、リソースで説明されている TI 製品を使用するアプリケーションの開発の目的でのみ、TI はその使用をお客様に許諾します。これらのリソースに関して、他の目的で複製することや掲載することは禁止されています。TI や第三者の知的財産権のライセンスが付与されている訳ではありません。お客様は、これらのリソースを自身で使用した結果発生するあらゆる申し立て、損害、費用、損失、責任について、TI およびその代理人を完全に補償するものとし、TI は一切の責任を拒否します。

TI の製品は、[TI の販売条件](#)、[TI の総合的な品質ガイドライン](#)、[ti.com](#) または TI 製品などに関連して提供される他の適用条件に従い提供されます。TI がこれらのリソースを提供することは、適用される TI の保証または他の保証の放棄の拡大や変更を意味するものではありません。TI がカスタム、またはカスタマー仕様として明示的に指定していない限り、TI の製品は標準的なカタログに掲載される汎用機器です。

お客様がいかなる追加条項または代替条項を提案する場合も、TI はそれらに異議を唱え、拒否します。

Copyright © 2026, Texas Instruments Incorporated

最終更新日 : 2025 年 10 月