

AM243x Sitara™ Microcontrollers

1 Features

Processor cores:

- Up to 2× Dual-core Arm Cortex®-R5F MCU subsystems operating at up to 800MHz, highly-integrated for real-time processing
 - Dual-core Arm Cortex®-R5F clusters support dual-core and single-core operation
 - 32KB I-cache and 32KB D-cache per R5F core with SECDED ECC on all memories
 - Single-core: 128KB TCM per cluster (128KB TCM per R5F core)
 - Dual-core: 128KB TCM per cluster (64KB TCM per R5F core)
- 1× Single-core Arm Cortex®-M4F MCU at up to 400MHz
 - 256KB SRAM with SECDED ECC

Memory subsystem:

- Up to 2MB of On-chip RAM (OCSRAM) with SECDED ECC:
 - Can be divided into smaller banks in increments of 256KB for as many as 8 separate memory banks
 - Each memory bank can be allocated to a single core to facilitate software task partitioning
- DDR Subsystem (DDRSS)
 - Supports LPDDR4, DDR4 memory types
 - 16-bit data bus with inline ECC
 - Supports speeds up to 1600 MT/s

System on Chip (SoC) services:

- Device Management Security Controller (DMSC-L)
 - Centralized SoC system controller
 - Manages system services including initial boot, security, and clock/reset/power management
 - Communication with various processing units over message manager
 - Simplified interface for optimizing unused peripherals
 - On-Chip Debug functionality through JTAG and Trace interfaces)
- Data Movement Subsystem (DMSS)
 - Block Copy DMA (BCDMA)
 - Packet DMA (PKTDMA)
 - Secure Proxy (SEC_PROXY)
 - Ring Accelerator (RINGACC)
- Time Sync Subsystem
 - Central Platform Time Sync (CPTS) module
 - Timer Manager (TIMERMANAGER) with 1024 timers
 - Time Sync and Compare event interrupt routers

Industrial subsystem:

- 2× Gigabit Industrial Communication Subsystems (PRU_ICSSG)
 - Optional support for Profinet IRT, Profinet RT, EtherNet/IP, EtherCAT, Time-Sensitive Networking (TSN), and other Networking Protocols
 - Backwards compatibility with 10/100Mb PRU-ICSS
 - Each PRU_ICSSG contains:
 - 3× PRU RISC Cores per Slice (2× Slice per PRU_ICSSG)
 - PRU General Use core (PRU)
 - PRU Real-Time Unit core (PRU-RTU)
 - PRU Transmit core (PRU-TX)
 - Each PRU core supports the following features:
 - Instruction RAM with ECC
 - Broadside RAM
 - Multiplier with optional accumulator (MAC)
 - CRC16/32 hardware accelerator
 - Byte swap for Big/Little Endian conversion
 - SUM32 hardware accelerator for UDP checksum
 - Task Manager for preemption support
- Up to 2× Ethernet ports
 - RGMII (10/100/1000)
 - MII (10/100)
- Three Data RAMs with ECC
- 8 banks of 30 × 32-bit register scratchpad memory
- Interrupt controller and task manager
- 2× 64-bit Industrial Ethernet Peripherals (IEPs) for time stamping and other time synchronization functions
- 18× Sigma-Delta Filter Module (SDFM) interfaces
 - Short circuit logic
 - Over-current logic
- 6× Multi-protocol position encoder interfaces
- 1× Enhanced Capture Module (ECAP)
- 16550-compatible UART
 - Dedicated 192MHz clock to support 12Mbps PROFIBUS

Security:

- Secure boot supported
 - Hardware-enforced Root-of-Trust (RoT)
 - Support to switch RoT via backup key



- Support for takeover protection, IP protection, and anti-roll back protection
- Security co-processor (DMSC-L) for key and security management, with dedicated device level interconnect for security
 - Secure watchdog/timer/IPC
 - Extensive firewall support for isolation
- Cryptographic acceleration supported
 - Session-aware cryptographic engine with ability to auto-switch key-material based on incoming data stream
 - Supports cryptographic cores
 - AES – 128-/192-/256-Bit key sizes
 - SHA2 – 224-/256-/384-/512-Bit key sizes
 - DRBG with true random number generator
 - PKA (Public Key Accelerator) to Assist in RSA/ECC processing for secure boot
- Debugging security
 - Secure software controlled debug access
 - Security aware debugging

General connectivity peripherals:

- 6× Inter-Integrated Circuit (I²C) ports
- 9× Universal Asynchronous Receive/Transmit (UART) modules
- 1× 12-bit Analog-to-Digital Converters (ADC)
 - Configurable sample rate up to 4MSPS
 - 8× multiplexed analog inputs
- 7× Multichannel Serial Peripheral Interfaces (SPI) controllers
- 3× General-Purpose I/O (GPIO) modules

Industrial and control interfaces:

- 9× Enhanced Pulse-Width Modulator (EPWM) modules
- 3× Enhanced Capture (ECAP) modules
- 3× Enhanced Quadrature Encoder Pulse (EQEP) modules
- 2× Modular Controller Area Network (MCAN) modules with full CAN-FD support
- 2× Fast Serial Interface Transmitter (FSITX) cores
- 6× Fast Serial Interface Receiver (FSIRX) cores

High-speed interfaces:

- 1× Integrated Ethernet switch supporting: (CPSW)
 - Up to 2 external Ethernet ports
 - RGMII (10/100/1000)
 - RMII (10/100)
 - IEEE 1588 (2008 Annex D, Annex E, Annex F) with 802.1AS PTP
 - Clause 45 MDIO PHY management
 - Energy efficient Ethernet (802.3az)
- 1× PCI-Express® Gen2 controller (PCIE)
 - Supports Gen2 Single Lane operation
- 1× USB 3.1 Dual-Role Device (DRD) Subsystem (USBSS)
 - Port configurable as USB Host, USB Device, or USB Dual-Role device
 - USB Device: High-speed (480Mbps) and Full-speed (12Mbps)
 - USB Host: SuperSpeed Gen1 (5Gbps), High-speed (480Mbps), Full-speed (12Mbps), and Low-speed (1.5Mbps)
 - Integrated USB VBUS detection
- 1× Serializer/Deserializer (SERDES)
 - One SERDES PHY lane to support either PCI-Express® Gen2 or USB SuperSpeed Gen1

Media and data storage:

- 2× Multimedia Card/Secure Digital (MMCSD) interfaces
 - One 8-bit for eMMC (MMCSD0)
 - One 4-bit for MMCSD/SDIO (MMCSD1)
 - Integrated analog switch for voltage switching from 3.3V to 1.8V for high-speed cards
- 1× General-Purpose Memory Controller (GPMC)
 - 16-bit parallel bus with 133MHz clock or
 - 32-bit parallel bus with 100MHz clock
 - Error Location Module (ELM) support
- 1× Flash Subsystem (FSS) for external memory configurable as either:
 - 1× Octal SPI (OSPI) flash interface
 - or 1× Quad SPI (QSPI) flash interface

Power management:

- Simplified power sequencing requirements
- Dual-voltage I/O Support (3.3V / 1.8V)
- Integrated SDIO LDO for handling automatic voltage transition for SD interface
- Integrated voltage supervisor for monitoring over-voltage and under-voltage conditions
- Integrated power supply glitch detector for detecting fast supply transients

Functional safety:

- [Functional Safety-Compliant](#)
 - Developed for functional safety applications
 - Documentation available to aid IEC 61508 functional safety system design
 - Systematic capability up to SIL 3
 - Hardware integrity up to SIL 2
 - Safety-related certification
 - [IEC 61508 certification by TUV SUD](#)
 - ECC or parity on calculation-critical memories
 - Built-In Self-Test (BIST) for CPU and on-chip RAM
 - Error Signaling Module (ESM) with dedicated error pin
 - ECC and parity on select internal bus interconnects
 - Run-time safety diagnostics, including:
 - Voltage, Temperature, and Clock Monitoring
 - Windowed Watchdog Timers
 - CRC Engine for memory integrity checks
 - MCU domain with dedicated memory, interfaces, and M4FSS capable of isolation from the larger SoC with Freedom From Interference (FFI) features:
 - Separate interconnect
 - Firewalls and timeout gaskets
 - Controlled reset isolation
 - Dedicated MCU PLL and MMR control
 - Separate I/O voltage supply rail

SoC architecture:

- Supports boot from OSPI/QSPI Flash, SPI Flash, parallel NOR Flash, parallel NAND Flash, UART, I2C, MMCSDB, eMMC, USB, PCIe, and Ethernet interfaces.
- 16-nm FinFET technology

Package options:

- ALV: 17.2mm × 17.2mm, 0.8mm pitch (441-pin) [Lidded] Flip-Chip Ball Grid Array (FCBGA)
- ANI: 17.2mm × 17.2mm, 0.8mm pitch (441-pin) [Lidded] Flip-Chip Ball Grid Array (FCBGA)
- ALX: 11.0mm × 11.0mm, 0.5mm pitch (293-pin) [Overmolded] Flip-Chip Chip Scale Package (FCCSP)

2 Applications

- [Programmable Logic Controller \(PLC\)](#)
- [Motor drives](#)
- [Remote I/O](#)
- [Factory automation robots](#)
- [Industrial & collaborative robots](#)
- [Condition-monitoring gateway](#)
- [Communication module](#)
- [Field transmitter](#)
- [Test & measurement](#)
- [Industrial mobile robots](#)
- [Home automation robots](#)
- [General-purpose controller](#)

3 Description

AM243x is an extension of Sitara's industrial-grade portfolio into high-performance microcontrollers. The AM243x device is built for industrial applications, such as motor drives and remote I/O modules, which require a combination of real-time communications and processing. The AM243x family provides scalable performance with up to four Cortex-R5F MCUs, one Cortex-M4F, and two instances of Sitara's gigabit TSN-enabled PRU_ICSSG.

The AM243x SoC architecture was designed to provide best-in-class real-time performance through the high-performance Arm Cortex-R5F cores, Tightly-Coupled Memory (TCM) banks, configurable SRAM partitioning, and dedicated low-latency paths to and from peripherals for rapid data movement in and out of the SoC. This deterministic architecture allows for AM243x to handle the tight control loops found in servo drives while the peripherals like FSI, GPMC, ECAPs, PWMs, and encoder interfaces help enable a number of different architectures found in these systems.

The SoC provides flexible industrial communications capability including full protocol stacks for EtherCAT target, PROFINET device, EtherNet/IP adapter, and IO-Link Controller. The PRU_ICSSG further provides capability for gigabit and TSN based protocols. In addition, the PRU_ICSSG enables additional interfaces including a UART interface, sigma delta decimation filters, and absolute encoder interfaces.

Functional safety features can be enabled through the integrated Cortex-M4F along with dedicated peripherals which can all be isolated from the rest of the SoC. AM243x also supports secure boot.

Package Information

| PART NUMBER | PACKAGE ⁽¹⁾ | PACKAGE SIZE ⁽²⁾ |
|-------------|------------------------|-----------------------------|
| AM2434 | ALV/ANI (FCBGA, 441) | 17.2mm × 17.2mm |
| | ALX (FCCSP, 293) | 11.0mm × 11.0mm |
| AM2432 | ALV/ANI (FCBGA, 441) | 17.2mm × 17.2mm |
| | ALX (FCCSP, 293) | 11.0mm × 11.0mm |
| AM2431 | ALV (FCBGA, 441) | 17.2mm × 17.2mm |
| | ALX (FCCSP, 293) | 11.0mm × 11.0mm |

(1) For more information, see [Mechanical, Packaging, and Orderable Information](#).

(2) The package size (length × width) is a nominal value and includes pins, where applicable.

3.1 Functional Block Diagram

Figure 3-1 is the functional block diagram for the device.

Note

Refer to the [AM243x SW Build Sheet](#) to understand which device features are currently supported by TI Software Development Kits (SDKs).

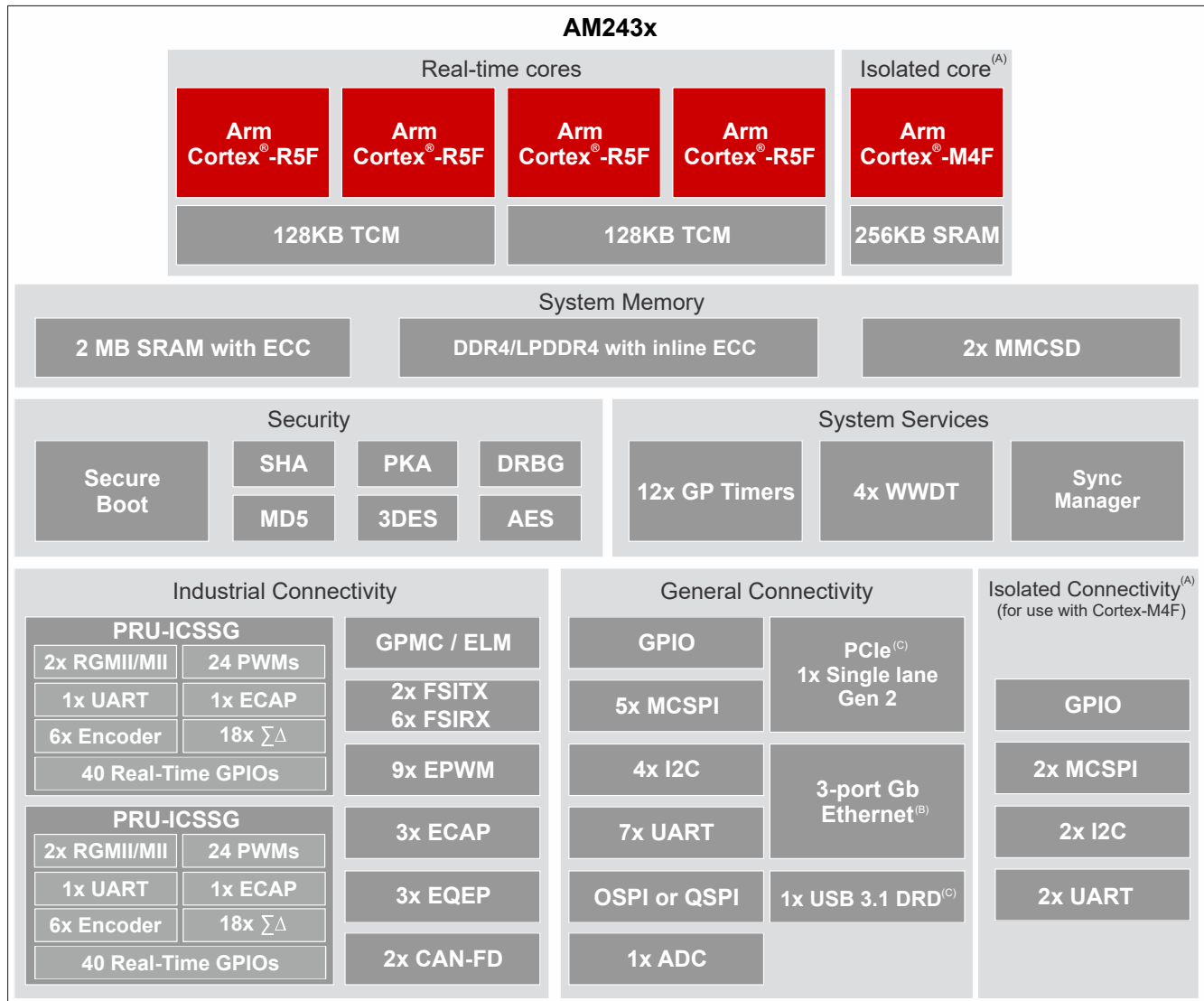

- A. Isolation of peripherals and M4F core is an optional feature. MCU domain resources are shared across the SoC when in non-isolated configuration.
- B. One port is connected internally and not routed to any external pins.
- C. USB3.1 and PCIe share a common SERDES PHY lane. USB will be limited to non-SuperSpeed modes when using the SERDES PHY for PCIe.

Figure 3-1. Functional Block Diagram

Table of Contents

| | | | |
|---|-----|--|-----|
| 1 Features | 1 | 6.11 Timing and Switching Characteristics..... | 120 |
| 2 Applications | 3 | 7 Detailed Description | 240 |
| 3 Description | 4 | 7.1 Overview..... | 240 |
| 3.1 Functional Block Diagram..... | 5 | 7.2 Processor Subsystems..... | 241 |
| 4 Device Comparison | 7 | 7.3 Accelerators and Coprocessors..... | 242 |
| 4.1 Related Products..... | 9 | 7.4 Other Subsystems..... | 242 |
| 5 Terminal Configuration and Functions | 10 | 8 Applications, Implementation, and Layout | 250 |
| 5.1 Pin Diagram..... | 10 | 8.1 Device Connection and Layout Fundamentals..... | 250 |
| 5.2 Pin Attributes..... | 12 | 8.2 Peripheral- and Interface-Specific Design Information..... | 251 |
| 5.3 Signal Descriptions..... | 57 | 8.3 Clock Routing Guidelines..... | 258 |
| 5.4 Pin Connectivity Requirements..... | 95 | 9 Device and Documentation Support | 259 |
| 6 Specifications | 101 | 9.1 Device Nomenclature..... | 259 |
| 6.1 Absolute Maximum Ratings..... | 101 | 9.2 Tools and Software..... | 262 |
| 6.2 ESD Ratings..... | 103 | 9.3 Documentation Support..... | 262 |
| 6.3 Power-On Hours (POH)..... | 104 | 9.4 Support Resources..... | 263 |
| 6.4 Recommended Operating Conditions..... | 105 | 9.5 Trademarks..... | 263 |
| 6.5 Operating Performance Points..... | 107 | 9.6 Electrostatic Discharge Caution..... | 263 |
| 6.6 Power Consumption Summary..... | 107 | 9.7 Glossary..... | 263 |
| 6.7 Electrical Characteristics..... | 108 | 10 Revision History | 264 |
| 6.8 VPP Specifications for One-Time Programmable (OTP) eFuses..... | 117 | 11 Mechanical, Packaging, and Orderable Information | 266 |
| 6.9 Thermal Resistance Characteristics..... | 118 | 11.1 Packaging Information..... | 266 |
| 6.10 Temperature Sensor Characteristics..... | 119 | | |

4 Device Comparison

Table 4-1 shows a comparison between devices options, and highlights the key differences.

Note

Availability of features listed in this table are a function of shared IO pins, where IO signals associated with many of the features are multiplexed to a limited number of pins. The SysConfig-PinMux tool should be used to assign signal functions to pins. This will provide a better understanding of limitations associated with pin multiplexing.

Note

To understand what device features are currently supported by TI Software Development Kits (SDKs), see the [AM243x SW Build Sheet](#).

Note

Features availability may vary by package within an orderable part number.

Table 4-1. Device Comparison

| FEATURES ⁽¹⁾ | REFERENCE NAME | AM2434 (ALV/ANI) | AM2432 (ALV/ANI) | AM2431 (ALV) | AM2434 (ALX) | AM2432 (ALX) | AM2431 (ALX) |
|--|----------------|--|-------------------------------------|---------------------------|---|-------------------------------------|---------------------------|
| MAIN_CTRL_MMR_CFG0_JTAG_USER_ID[31:13]⁽²⁾ | | | | | | | |
| Register bit values by device "Features" code (See Nomenclature Description table for more information on device features) | | | | | | | |
| | C: | – | 0x19023 | 0x19003 | – | 0x19023 | 0x19003 |
| | D: | 0x19064 | 0x19024 | 0x19004 | 0x19064 | 0x19024 | 0x19004 |
| | E: | 0x19065 | 0x19025 | – | 0x19065 | 0x19025 | – |
| | F: | 0x19066 | 0x19026 | – | 0x19066 | 0x19026 | – |
| PROCESSORS AND ACCELERATORS | | | | | | | |
| Speed Grades (See Table 6-1) | | S | S | S | S | S, K | S,K |
| Arm Cortex-R5F | R5FSS | 2 × Dual Core R5F0_0 R5F0_1 R5F1_0 R5F1_1 | 2 × Single Core R5F0_0 R5F1_0 | 1 × Single Core R5F0_0 | 2 × Dual Core R5F0_0 R5F0_1 R5F1_0 R5F1_1 | 2 × Single Core R5F0_0 R5F1_0 | 1 × Single Core R5F0_0 |
| Arm Cortex-M4F | M4FSS | 1 × Single Core Functional Safety Optional ⁽³⁾ | | | | | |
| Device Management Security Controller | DMSC-L | Yes | | | | | |
| Crypto Accelerators | Security | Yes | | | | | |
| PROGRAM AND DATA STORAGE | | | | | | | |
| Shared On-Chip Memory (OCSRAM) in MAIN Domain | OCSRAM | 2MB | | | 2MB | | |
| R5F Tightly Coupled Memory (TCM) ⁽⁴⁾ | TCM | 4 × 64KB | 2 × 128KB | 1 × 128KB | 4 × 64KB | 2 × 128KB | 1 × 128KB |
| Shared On-Chip Memory (OCSRAM) in MCU Domain | MCU_MSRAM | 1 × 256KB | | | | | |
| DDR4/LPDDR4 DDR Subsystem | DDRSS | Up to 2GB (16-bit data) with inline ECC | | | - | | |
| General-Purpose Memory Controller | GPMC | Up to 128MB with ECC | | | - | | |
| PERIPHERALS | | | | | | | |
| Modular Controller Area Network Interface | MCAN | 2 | | | | | |
| Full CAN-FD Support ⁽⁵⁾ | MCAN | Optional | | | | | |
| General-Purpose I/O | GPIO | Up to 198 | | | Up to 148 | | |

Table 4-1. Device Comparison (continued)

| FEATURES ⁽¹⁾ | REFERENCE NAME | AM2434 (ALV/ANI) | AM2432 (ALV/ANI) | AM2431 (ALV) | AM2434 (ALX) | AM2432 (ALX) | AM2431 (ALX) |
|---|----------------|------------------------|------------------|------------------|---------------------------------------|--------------|--------------|
| Inter-Integrated Circuit Interface | I2C | 6 (2 in MCU Domain) | | | 3 (MAIN Domain Only) | | |
| Analog-to-Digital Converter | ADC | 1 (12-bit resolution) | | | 1 (10-bit resolution) | | |
| Multichannel Serial Peripheral Interface | MCSPi | 7 (2 in MCU Domain) | | | 4 (MAIN Domain Only) | | |
| MultiMedia Card/ Secure Digital Interface | MMcSD0 | eMMC (8-bits) | | | - | | |
| | MMcSD1 | SD/SDIO (4-bits) | | | SD/SDIO (4-bits) | | |
| Fast Serial Interface | FSI_TX | 2 | | | 1 | | |
| | FSI_RX | 6 | | | 4 | | |
| Flash Subsystem (FSS) | OSPI0 | Yes ⁽⁶⁾ | | | QSPI-Mode Only | | |
| PCI Express Port with Integrated PHY | PCIE | Single Lane | | | - | | |
| Programmable Real-Time Unit Subsystem ⁽⁷⁾ (PRU Cores, eGPIO, UART, ECAP, EPWM) | PRU_ICSSG | 2 | | | | | |
| Industrial Communication Subsystem Support ⁽⁸⁾ (RGMII/MII and additional Networking Interfaces) | PRU_ICSSG | Optional | | | | | |
| Gigabit Ethernet Interface | CPSW | Yes (2 External Ports) | | | | | |
| General-Purpose Timers | TIMER | 16 (4 in MCU Domain) | | | | | |
| Enhanced Pulse-Width Modulation Module | EPWM | 9 | | 7 ⁽⁹⁾ | | | |
| Enhanced Capture Module | ECAP | 3 | | | | | |
| Enhanced Quadrature Encoder Pulse Module | EQEP | 3 | | | | | |
| Universal Asynchronous Receiver/Transmitter | UART | 9 (2 in MCU Domain) | | | 8 (1 in MCU Domain) | | |
| Universal Serial Bus (USB3.1 Gen1) SuperSpeed Dual-Role-Device (DRD) Port with SS PHY | USB | Yes ⁽¹⁰⁾ | | | No USB SuperSpeed Support (USB2 Only) | | |

- (1) Features noted as “not supported” or “-”, must not be used. Their functionality is not supported by TI for this family of devices. These features are subject to removal without notice on future device revisions. Any information regarding the unsupported features has been retained in the documentation solely for the purpose of clarifying signal names or for consistency with previous feature descriptions.
- (2) For more details about the MAIN_CTRL_MMR_CFG0_JTAG_USER_ID register and DEVICE_ID bit field, see the device’s associated *Technical Reference Manual*.
- (3) Functional Safety is available when selecting an orderable part number that includes a feature code of F. Refer to [Nomenclature Description](#) table for the definition of feature codes.
- (4) The R5F cores share Tightly-Coupled Memory within a cluster and can be allocated per system requirements.
- (5) Full CAN-FD Support is available when selecting an orderable part number that includes a feature code of E or F. Refer to [Nomenclature Description](#) table for the definition of feature codes.
- (6) One flash interface configured as OSPI0 or QSPI0.
- (7) Programmable Real-Time Unit Subsystem support (Including Ethernet networking (MII/RGMII, MDIO), Sigma-Delta (SD) decimation, and three channel peripheral interface (EnDat 2.2 and BiSS)) is available when selecting an orderable part number that includes a feature code of C. Refer to [Nomenclature Description](#) table for the definition of feature codes.
- (8) Industrial Communication Subsystem feature support is available when selecting an orderable part number that includes a feature code of D, E, or F. Refer to [Nomenclature Description](#) table for the definition of feature codes.
- (9) Only the PWM_A output signal is available for the EHRPWM5 instance of the ALX package type.
- (10) Please refer to device Software Build sheet for details regarding USB driver support.

4.1 Related Products

Sitara™ Microcontrollers Our best-in-class Arm®-based 32-bit microcontrollers (MCUs) offer you a scalable portfolio of high-performance and power-efficient devices to help meet your system needs. Bring capabilities such as functional safety, power efficiency, real-time control, advanced networking, analytics and security to your designs.

Sitara™ Processors Broad family of scalable processors based on Arm® Cortex®-A cores with flexible accelerators, peripherals, connectivity and unified software support – perfect for sensors to servers. Sitara™ processors have the features and reliability needed for use in industrial and automotive applications.

Sitara™ Microcontroller - Applications Sitara™ microcontrollers provides a scalable portfolio for a wide range of applications from HMI and gateways to more complex equipment such as drives and substation automation equipment. Sitara also offers multi-protocol support for industrial communication protocols such as EtherCAT®, Ethernet/IP, and Profinet.

Sitara™ Microcontroller - Evaluation Modules TI provides Evaluation Modules (EVM) to help kick-start product development. See the AM243x Evaluation Module ([TMDSAM243](#)) and AM243x LaunchPad ([LP-AM243x](#)) tool folders for more information.

Companion Products for AM243x Review products that are frequently purchased or used in conjunction with this product to complete your design.

Additional products to complete your design:

- [Ethernet PHYs](#)
- [Power supply solutions](#)
- [Power management](#)
- [Clocks and timing](#)
- [Power switches](#)
- [CAN transceivers](#)
- [ESD Protection](#)

Please reference the AM243x EVM schematic for details of how these devices are implemented in a system design, and bill of materials for specific part number recommendations.

5 Terminal Configuration and Functions

5.1 Pin Diagram

Note

The terms "ball", "pin", and "terminal" are used interchangeably throughout the document. An attempt is made to use "ball" only when referring to the physical package.

The diagrams in this section are used in conjunction with the other Terminal Configuration and Functions tables to locate signal names and ball grid numbers. The HTML version of this document provides additional information when hovering your cursor over a ball.

5.1.1 AM243x ALV/ANI Pin Diagram

Figure 5-1 shows the ball locations for the lidded 441-ball flip chip ball grid array (FCBGA) package.

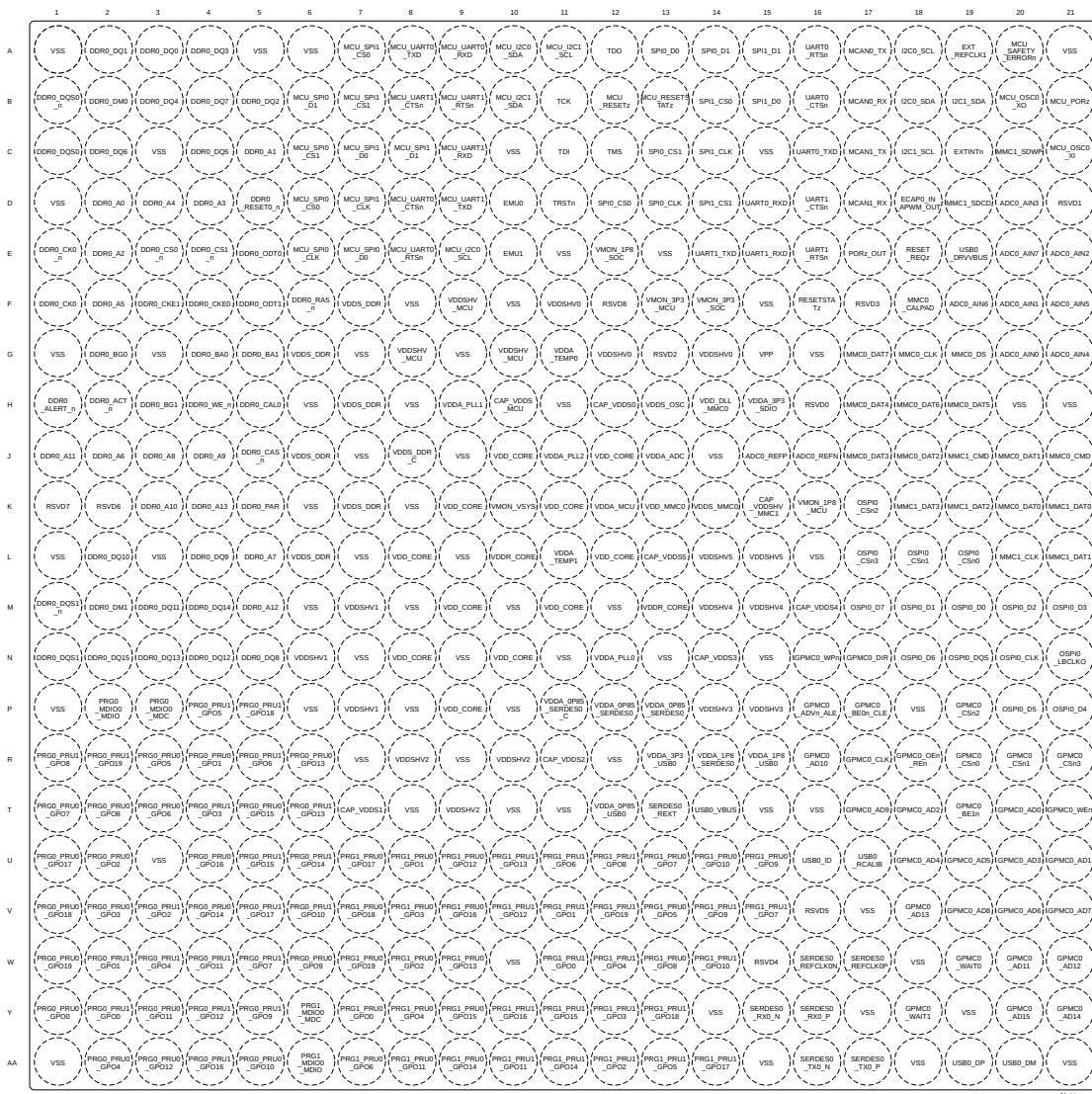

Figure 5-1. ALV/ANI FCBGA-N441 Pin Diagram (Top View)

5.1.2 AM243x ALX Pin Diagram

The Figure 5-2 shows the ball locations for the non-lidded 293-ball flip chip ball grid array (FCBGA) package.

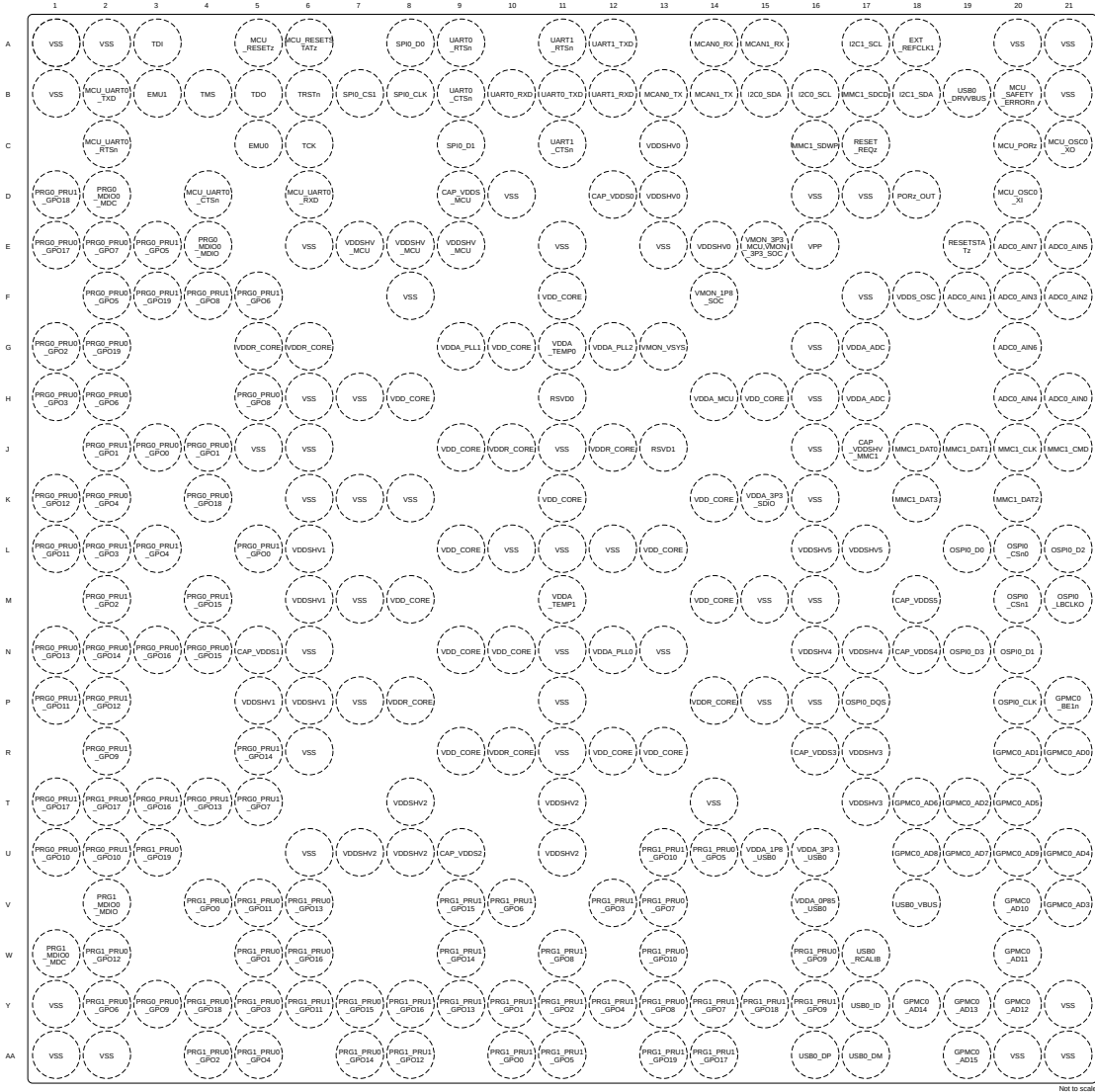

Figure 5-2. ALX FCBGA-N293 Pin Diagram (Top View)

5.2 Pin Attributes

The following list describes the contents of each column in the *Pin Attributes* table:

1. **BALL NUMBER:** Ball numbers assigned to each terminal of the Ball Grid Array package.
2. **BALL NAME:** Ball name assigned to each terminal of the Ball Grid Array package (this name is typically taken from the primary MUXMODE 0 signal function).
3. **SIGNAL NAME:** Signal name(s) of all dedicated and pin multiplexed signal functions associated with a ball.

Note

Many device pins support multiple signal functions. Some signal functions are selected via a single layer of multiplexers associated with pins. Other signal functions are selected via two or more layers of multiplexers, where one layer is associated with the pins and other layers are associated with peripheral logic functions.

The *Pin Attributes* table, defines the SoC pin multiplexed signal function implemented at the pin and **does not** define secondary multiplexing of signal functions implemented in device subsystems. Secondary multiplexing of signal functions are not described in this table. For more information on secondary multiplexed signal functions, see the respective peripheral chapter of the device TRM.

4. **MUX MODE:** The MUXMODE value associated with each pin multiplexed signal function:
 - a. MUXMODE 0 is the primary pin multiplexed signal function. However, the primary pin multiplexed signal function is not necessarily the default pin multiplexed signal function.

Note

The value found in the MUX MODE AFTER RESET column defines the default pin multiplexed signal function selected when MCU_PORz is deasserted.

- b. MUXMODE values 1 through 15 are possible for pin multiplexed signal functions. However, not all MUXMODE values have been implemented. The only valid MUXMODE values are those defined as pin multiplexed signal functions within the Pin Attributes table. Only valid values of MUXMODE can be used.
- c. Bootstrap defines SOC configuration pins, where the logic state applied to each pin is latched on the rising edge of PORz_OUT. These input signal functions are fixed to their respective pins and are not programmable via MUXMODE.
- d. An empty box means Not Applicable.

Note

The following configurations of MUXMODE must be avoided for proper device operation.

- Configuring multiple pins operating as inputs to the same pin multiplexed signal function is not supported as it can yield unexpected results.
 - Configuring a pin to an undefined pin multiplexing mode will cause the pin behavior to be undefined.
-

5. **TYPE:** Signal type and direction:
 - I = Input
 - O = Output
 - OD = Output, with open-drain output function
 - IO = Input, Output, or simultaneously Input and Output
 - IOD = Input, Output, or simultaneously Input and Output, with open-drain output function
 - IOZ = Input, Output, or simultaneously Input and Output, with three-state output function
 - OZ = Output with three-state output function
 - A = Analog
 - PWR = Power
 - GND = Ground
 - CAP = LDO Capacitor

6. **DSIS:** The deselected input state (DSIS) indicates the state driven to the subsystem input (logic "0", logic "1", or "pad" level) when the pin multiplexed signal function is not selected by MUXMODE.
 - 0: Logic 0 driven to the subsystem input.
 - 1: Logic 1 driven to the subsystem input.
 - pad: Logic state of the pad is driven to the subsystem input.
 - An empty box means Not Applicable.

7. **BALL STATE DURING RESET RX/TX/PULL:** State of the terminal while MCU_PORz is asserted, where RX defines the state of the input buffer, TX defines the state of the output buffer, and PULL defines the state of internal pull resistors:
 - RX (Input buffer)
 - Off: The input buffer is disabled.
 - On: The input buffer is enabled.
 - TX (Output buffer)
 - Off: The output buffer is disabled.
 - Low: The output buffer is enabled and drives V_{OL} .
 - High: The output buffer is enabled and drives V_{OH} .
 - PULL (Internal pull resistors)
 - Off: Internal pull resistors are turned off.
 - Up: Internal pull-up resistor is turned on.
 - Down: Internal pull-down resistor is turned on.
 - NA: Not Applicable.
 - An empty box means Not Applicable.

8. **BALL STATE AFTER RESET RX/TX/PULL:** State of the terminal after MCU_PORz is deasserted, where RX defines the state of the input buffer, TX defines the state of the output buffer, and PULL defines the state of internal pull resistors:
 - RX (Input buffer)
 - Off: The input buffer is disabled.
 - On: The input buffer is enabled.
 - TX (Output buffer)
 - Off: The output buffer is disabled.
 - SS: The subsystem selected with MUXMODE determines the output buffer state.
 - PULL (Internal pull resistors)
 - Off: Internal pull resistors are turned off.
 - Up: Internal pull-up resistor is turned on.
 - Down: Internal pull-down resistor is turned on.
 - NA: Not Applicable.
 - An empty box, NA, or "-" means Not Applicable.

9. **MUX MODE AFTER RESET:** The value found in this column defines the default pin multiplexed signal function after MCU_PORz is deasserted.
- An empty box means Not Applicable.
10. **I/O OPERATING VOLTAGE:** This column describes I/O operating voltage options of the respective power supply, when applicable.
- An empty box means Not Applicable.
- For more information, see valid operating voltage range(s) defined for each power supply in *Recommended Operating Conditions*.
11. **POWER:** The power supply of the associated I/O, when applicable.
- An empty box means Not Applicable.
12. **HYS:** Indicates if the input buffer associated with this I/O has hysteresis:
- Yes: With hysteresis
 - No: Without hysteresis
 - An empty box means Not Applicable.
- For more information, see the hysteresis values in *Electrical Characteristics*.
13. **PULL UP/DOWN TYPE:** Indicates the presence of an internal pull-up or pull-down resistor. Internal resistors can be enabled or disabled via software.
- PU: Internal pull-up
 - PD: Internal pull-down
 - PU/PD: Internal pull-up and pull-down
 - An empty box means No internal pull.
14. **BUFFER TYPE:** This column defines the buffer type associated with a terminal. This information can be used to determine which Electrical Characteristics table is applicable.
- An empty box means Not Applicable.
- For electrical characteristics, refer to the appropriate buffer type table in *Electrical Characteristics*.
15. **PADCONFIG Register:** Name of the IO pad configuration register associated with Ball.
16. **PADCONFIG Address:** Physical address of the IO pad configuration register associated with Ball.

Table 5-1. Pin Attributes (ALV, ANI, ALX Packages)

| ALV ANI BALL NUMBER [1] | ALX BALL NUMBER [1] | BALL NAME [2] PADCONFIG Register [15] PADCONFIG Address [16] | SIGNAL NAME [3] | MUX MODE [4] | TYPE [5] | DSIS [6] | BALL STATE DURING RESET RX/TX/PULL [7] | BALL STATE AFTER RESET RX/TX/PULL [8] | MUX MODE AFTER RESET [9] | IO OPERATING VOLTAGE [10] | POWER [11] | HYS [12] | BUFFER TYPE [14] | Pull UP/DOWN TYPE [13] |
|-------------------------------------|------------------------------|--|---------------------------------|-----------------|-------------|-------------|---|--|--------------------------------------|---------------------------------|-------------------------|-------------|---------------------|------------------------------|
| J16 | | ADC0_REFN | ADC0_REFN | | A | | | | | 1.8V | VDDA_ADC0 | | ADC12B | |
| J15 | | ADC0_REFP | ADC0_REFP | | A | | | | | 1.8V | VDDA_ADC0 | | ADC12B | |
| G20 | H21 | ADC0_AIN0 | ADC0_AIN0 | | A | | | | | 1.8V | VDDA_ADC0 | Yes | ADC12B | |
| F20 | F19 | ADC0_AIN1 | ADC0_AIN1 | | A | | | | | 1.8V | VDDA_ADC0 | Yes | ADC12B | |
| E21 | F21 | ADC0_AIN2 | ADC0_AIN2 | | A | | | | | 1.8V | VDDA_ADC0 | Yes | ADC12B | |
| D20 | F20 | ADC0_AIN3 | ADC0_AIN3 | | A | | | | | 1.8V | VDDA_ADC0 | Yes | ADC12B | |
| G21 | H20 | ADC0_AIN4 | ADC0_AIN4 | | A | | | | | 1.8V | VDDA_ADC0 | Yes | ADC12B | |
| F21 | E21 | ADC0_AIN5 | ADC0_AIN5 | | A | | | | | 1.8V | VDDA_ADC0 | Yes | ADC12B | |
| F19 | G20 | ADC0_AIN6 | ADC0_AIN6 | | A | | | | | 1.8V | VDDA_ADC0 | Yes | ADC12B | |
| E20 | E20 | ADC0_AIN7 | ADC0_AIN7 | | A | | | | | 1.8V | VDDA_ADC0 | Yes | ADC12B | |
| H12 | D12 | CAP_VDDS0 | CAP_VDDS0 | | CAP | | | | | | | | | |
| T7 | N5 | CAP_VDDS1 | CAP_VDDS1 | | CAP | | | | | | | | | |
| R11 | U9 | CAP_VDDS2 | CAP_VDDS2 | | CAP | | | | | | | | | |
| N14 | R16 | CAP_VDDS3 | CAP_VDDS3 | | CAP | | | | | | | | | |
| M16 | N18 | CAP_VDDS4 | CAP_VDDS4 | | CAP | | | | | | | | | |
| L13 | M18 | CAP_VDDS5 | CAP_VDDS5 | | CAP | | | | | | | | | |
| K15 | J17 | CAP_VDDSHV_MMC1 | CAP_VDDSHV_MMC1 | | CAP | | | | | | | | | |
| H10 | D9 | CAP_VDDS_MCU | CAP_VDDS_MCU | | CAP | | | | | | | | | |
| H2 | | DDR0_ACT_n | DDR0_ACT_n | | O | | | | | 1.1V / 1.2V | VDDS_DDR, VDDS_DDR_C | | DDR | |
| H1 | | DDR0_ALERT_n | DDR0_ALERT_n | | IO | | | | | 1.1V / 1.2V | VDDS_DDR, VDDS_DDR_C | | DDR | |
| J5 | | DDR0_CAS_n | DDR0_CAS_n | | O | | | | | 1.1V / 1.2V | VDDS_DDR, VDDS_DDR_C | | DDR | |
| K5 | | DDR0_PAR | DDR0_PAR | | O | | | | | 1.1V / 1.2V | VDDS_DDR, VDDS_DDR_C | | DDR | |
| F6 | | DDR0_RAS_n | DDR0_RAS_n | | O | | | | | 1.1V / 1.2V | VDDS_DDR, VDDS_DDR_C | | DDR | |
| H4 | | DDR0_WE_n | DDR0_WE_n | | O | | | | | 1.1V / 1.2V | VDDS_DDR, VDDS_DDR_C | | DDR | |
| D2 | | DDR0_A0 | DDR0_A0 | | O | | | | | 1.1V / 1.2V | VDDS_DDR, VDDS_DDR_C | | DDR | |
| C5 | | DDR0_A1 | DDR0_A1 | | O | | | | | 1.1V / 1.2V | VDDS_DDR, VDDS_DDR_C | | DDR | |
| E2 | | DDR0_A2 | DDR0_A2 | | O | | | | | 1.1V / 1.2V | VDDS_DDR, VDDS_DDR_C | | DDR | |
| D4 | | DDR0_A3 | DDR0_A3 | | O | | | | | 1.1V / 1.2V | VDDS_DDR, VDDS_DDR_C | | DDR | |
| D3 | | DDR0_A4 | DDR0_A4 | | O | | | | | 1.1V / 1.2V | VDDS_DDR, VDDS_DDR_C | | DDR | |

Table 5-1. Pin Attributes (ALV, ANI, ALX Packages) (continued)

| ALV ANI BALL NUMBER [1] | ALX BALL NUMBER [1] | BALL NAME [2] PADCONFIG Register [15] PADCONFIG Address [16] | SIGNAL NAME [3] | MUX MODE [4] | TYPE [5] | DSIS [6] | BALL STATE DURING RESET RX/TX/PULL [7] | BALL STATE AFTER RESET RX/TX/PULL [8] | MUX MODE AFTER RESET [9] | IO OPERATING VOLTAGE [10] | POWER [11] | HYS [12] | BUFFER TYPE [14] | Pull UP/DOWN TYPE [13] |
|-------------------------------------|------------------------------|--|----------------------------|-----------------|-------------|-------------|---|--|--------------------------------------|---------------------------------|-------------------------|-------------|---------------------|------------------------------|
| F2 | | DDR0_A5 | DDR0_A5 | | O | | | | | 1.1V / 1.2V | VDDS_DDR, VDDS_DDR_C | | DDR | |
| J2 | | DDR0_A6 | DDR0_A6 | | O | | | | | 1.1V / 1.2V | VDDS_DDR, VDDS_DDR_C | | DDR | |
| L5 | | DDR0_A7 | DDR0_A7 | | O | | | | | 1.1V / 1.2V | VDDS_DDR, VDDS_DDR_C | | DDR | |
| J3 | | DDR0_A8 | DDR0_A8 | | O | | | | | 1.1V / 1.2V | VDDS_DDR, VDDS_DDR_C | | DDR | |
| J4 | | DDR0_A9 | DDR0_A9 | | O | | | | | 1.1V / 1.2V | VDDS_DDR, VDDS_DDR_C | | DDR | |
| K3 | | DDR0_A10 | DDR0_A10 | | O | | | | | 1.1V / 1.2V | VDDS_DDR, VDDS_DDR_C | | DDR | |
| J1 | | DDR0_A11 | DDR0_A11 | | O | | | | | 1.1V / 1.2V | VDDS_DDR, VDDS_DDR_C | | DDR | |
| M5 | | DDR0_A12 | DDR0_A12 | | O | | | | | 1.1V / 1.2V | VDDS_DDR, VDDS_DDR_C | | DDR | |
| K4 | | DDR0_A13 | DDR0_A13 | | O | | | | | 1.1V / 1.2V | VDDS_DDR, VDDS_DDR_C | | DDR | |
| G4 | | DDR0_BA0 | DDR0_BA0 | | O | | | | | 1.1V / 1.2V | VDDS_DDR, VDDS_DDR_C | | DDR | |
| G5 | | DDR0_BA1 | DDR0_BA1 | | O | | | | | 1.1V / 1.2V | VDDS_DDR, VDDS_DDR_C | | DDR | |
| G2 | | DDR0_BG0 | DDR0_BG0 | | O | | | | | 1.1V / 1.2V | VDDS_DDR, VDDS_DDR_C | | DDR | |
| H3 | | DDR0_BG1 | DDR0_BG1 | | O | | | | | 1.1V / 1.2V | VDDS_DDR, VDDS_DDR_C | | DDR | |
| H5 | | DDR0_CAL0 | DDR0_CAL0 | | A | | | | | 1.1V / 1.2V | VDDS_DDR, VDDS_DDR_C | | DDR | |
| F1 | | DDR0_CK0 | DDR0_CK0 | | O | | | | | 1.1V / 1.2V | VDDS_DDR, VDDS_DDR_C | | DDR | |
| E1 | | DDR0_CK0_n | DDR0_CK0_n | | O | | | | | 1.1V / 1.2V | VDDS_DDR, VDDS_DDR_C | | DDR | |
| F4 | | DDR0_CKE0 | DDR0_CKE0 | | O | | | | | 1.1V / 1.2V | VDDS_DDR, VDDS_DDR_C | | DDR | |
| F3 | | DDR0_CKE1 | DDR0_CKE1 | | O | | | | | 1.1V / 1.2V | VDDS_DDR, VDDS_DDR_C | | DDR | |
| E3 | | DDR0_CS0_n | DDR0_CS0_n | | O | | | | | 1.1V / 1.2V | VDDS_DDR, VDDS_DDR_C | | DDR | |
| E4 | | DDR0_CS1_n | DDR0_CS1_n | | O | | | | | 1.1V / 1.2V | VDDS_DDR, VDDS_DDR_C | | DDR | |
| B2 | | DDR0_DM0 | DDR0_DM0 | | IO | | | | | 1.1V / 1.2V | VDDS_DDR, VDDS_DDR_C | | DDR | |
| M2 | | DDR0_DM1 | DDR0_DM1 | | IO | | | | | 1.1V / 1.2V | VDDS_DDR, VDDS_DDR_C | | DDR | |

Table 5-1. Pin Attributes (ALV, ANI, ALX Packages) (continued)

| ALV ANI BALL NUMBER [1] | ALX BALL NUMBER [1] | BALL NAME [2] PADCONFIG Register [15] PADCONFIG Address [16] | SIGNAL NAME [3] | MUX MODE [4] | TYPE [5] | DSIS [6] | BALL STATE DURING RESET RX/TX/PULL [7] | BALL STATE AFTER RESET RX/TX/PULL [8] | MUX MODE AFTER RESET [9] | IO OPERATING VOLTAGE [10] | POWER [11] | HYS [12] | BUFFER TYPE [14] | Pull UP/DOWN TYPE [13] |
|-------------------------------------|------------------------------|--|-----------------|-----------------|-------------|-------------|---|--|--------------------------------------|---------------------------------|-------------------------|-------------|---------------------|------------------------------|
| A3 | | DDR0_DQ0 | DDR0_DQ0 | | IO | | | | | 1.1V / 1.2V | VDDS_DDR, VDDS_DDR_C | | DDR | |
| A2 | | DDR0_DQ1 | DDR0_DQ1 | | IO | | | | | 1.1V / 1.2V | VDDS_DDR, VDDS_DDR_C | | DDR | |
| B5 | | DDR0_DQ2 | DDR0_DQ2 | | IO | | | | | 1.1V / 1.2V | VDDS_DDR, VDDS_DDR_C | | DDR | |
| A4 | | DDR0_DQ3 | DDR0_DQ3 | | IO | | | | | 1.1V / 1.2V | VDDS_DDR, VDDS_DDR_C | | DDR | |
| B3 | | DDR0_DQ4 | DDR0_DQ4 | | IO | | | | | 1.1V / 1.2V | VDDS_DDR, VDDS_DDR_C | | DDR | |
| C4 | | DDR0_DQ5 | DDR0_DQ5 | | IO | | | | | 1.1V / 1.2V | VDDS_DDR, VDDS_DDR_C | | DDR | |
| C2 | | DDR0_DQ6 | DDR0_DQ6 | | IO | | | | | 1.1V / 1.2V | VDDS_DDR, VDDS_DDR_C | | DDR | |
| B4 | | DDR0_DQ7 | DDR0_DQ7 | | IO | | | | | 1.1V / 1.2V | VDDS_DDR, VDDS_DDR_C | | DDR | |
| N5 | | DDR0_DQ8 | DDR0_DQ8 | | IO | | | | | 1.1V / 1.2V | VDDS_DDR, VDDS_DDR_C | | DDR | |
| L4 | | DDR0_DQ9 | DDR0_DQ9 | | IO | | | | | 1.1V / 1.2V | VDDS_DDR, VDDS_DDR_C | | DDR | |
| L2 | | DDR0_DQ10 | DDR0_DQ10 | | IO | | | | | 1.1V / 1.2V | VDDS_DDR, VDDS_DDR_C | | DDR | |
| M3 | | DDR0_DQ11 | DDR0_DQ11 | | IO | | | | | 1.1V / 1.2V | VDDS_DDR, VDDS_DDR_C | | DDR | |
| N4 | | DDR0_DQ12 | DDR0_DQ12 | | IO | | | | | 1.1V / 1.2V | VDDS_DDR, VDDS_DDR_C | | DDR | |
| N3 | | DDR0_DQ13 | DDR0_DQ13 | | IO | | | | | 1.1V / 1.2V | VDDS_DDR, VDDS_DDR_C | | DDR | |
| M4 | | DDR0_DQ14 | DDR0_DQ14 | | IO | | | | | 1.1V / 1.2V | VDDS_DDR, VDDS_DDR_C | | DDR | |
| N2 | | DDR0_DQ15 | DDR0_DQ15 | | IO | | | | | 1.1V / 1.2V | VDDS_DDR, VDDS_DDR_C | | DDR | |
| C1 | | DDR0_DQS0 | DDR0_DQS0 | | IO | | | | | 1.1V / 1.2V | VDDS_DDR, VDDS_DDR_C | | DDR | |
| B1 | | DDR0_DQS0_n | DDR0_DQS0_n | | IO | | | | | 1.1V / 1.2V | VDDS_DDR, VDDS_DDR_C | | DDR | |
| N1 | | DDR0_DQS1 | DDR0_DQS1 | | IO | | | | | 1.1V / 1.2V | VDDS_DDR, VDDS_DDR_C | | DDR | |
| M1 | | DDR0_DQS1_n | DDR0_DQS1_n | | IO | | | | | 1.1V / 1.2V | VDDS_DDR, VDDS_DDR_C | | DDR | |
| E5 | | DDR0_ODT0 | DDR0_ODT0 | | O | | | | | 1.1V / 1.2V | VDDS_DDR, VDDS_DDR_C | | DDR | |
| F5 | | DDR0_ODT1 | DDR0_ODT1 | | O | | | | | 1.1V / 1.2V | VDDS_DDR, VDDS_DDR_C | | DDR | |

Table 5-1. Pin Attributes (ALV, ANI, ALX Packages) (continued)

| ALV ANI BALL NUMBER [1] | ALX BALL NUMBER [1] | BALL NAME [2] PADCONFIG Register [15] PADCONFIG Address [16] | SIGNAL NAME [3] | MUX MODE [4] | TYPE [5] | DSIS [6] | BALL STATE DURING RESET RX/TX/PULL [7] | BALL STATE AFTER RESET RX/TX/PULL [8] | MUX MODE AFTER RESET [9] | IO OPERATING VOLTAGE [10] | POWER [11] | HYS [12] | BUFFER TYPE [14] | Pull UP/DOWN TYPE [13] |
|-------------------------------------|------------------------------|--|--|-----------------|-------------|-------------|---|--|--------------------------------------|---------------------------------|-------------------------|-------------|---------------------|------------------------------|
| D5 | | DDR0_RESET0_n | DDR0_RESET0_n | | O | | | | | 1.1V / 1.2V | VDDS_DDR, VDDS_DDR_C | | DDR | |
| D18 | | ECAP0_IN_APWM_OUT PADCONFIG: PADCONFIG156 0x000F4270 | ECAP0_IN_APWM_OUT | 0 | IO | 0 | Off / Off / Off | Off / Off / Off | 7 | 1.8V / 3.3V | VDDSHV0 | Yes | LVC MOS | PU/PD |
| | | | SYNC0_OUT | 1 | O | | | | | | | | | |
| | | | CPTS0_RFT_CLK | 2 | I | 0 | | | | | | | | |
| | | | CP_GEMAC_CPTS0_RFT_CLK | 5 | I | 0 | | | | | | | | |
| | | | SPI4_CS3 | 6 | IO | 1 | | | | | | | | |
| | | | GPIO1_68 | 7 | IO | pad | | | | | | | | |
| D10 | C5 | EMU0 PADCONFIG: MCU_PADCONFIG31 0x0408407C | EMU0 | 0 | IO | 1 | On / Off / Up | On / Off / Up | 0 | 1.8V / 3.3V | VDDSHV_MCU | Yes | LVC MOS | PU/PD |
| E10 | B3 | EMU1 PADCONFIG: MCU_PADCONFIG32 0x04084080 | EMU1 | 0 | IO | 1 | On / Off / Up | On / Off / Up | 0 | 1.8V / 3.3V | VDDSHV_MCU | Yes | LVC MOS | PU/PD |
| | | | MCU_OBSCLK0 | 15 | O | | | | | | | | | |
| C19 | | EXTINTn PADCONFIG: PADCONFIG158 0x000F4278 | EXTINTn | 0 | I | 1 | Off / Off / NA | Off / Off / NA | 7 | 1.8V / 3.3V | VDDSHV0 | Yes | I2C OD FS | |
| | | | GPIO1_70 | 7 | IOD | pad | | | | | | | | |
| A19 | A18 | EXT_REFCLK1 PADCONFIG: PADCONFIG157 0x000F4274 | EXT_REFCLK1 | 0 | I | 0 | Off / Off / Off | Off / Off / Off | 7 | 1.8V / 3.3V | VDDSHV0 | Yes | LVC MOS | PU/PD |
| | | | SYNC1_OUT | 1 | O | | | | | | | | | |
| | | | SPI2_CS3 | 2 | IO | 1 | | | | | | | | |
| | | | CLKOUT0 | 5 | O | | | | | | | | | |
| | | | GPIO1_69 | 7 | IO | pad | | | | | | | | |
| P16 | | GPMC0_ADVn_ALE PADCONFIG: PADCONFIG33 0x000F4084 | GPMC0_ADVn_ALE | 0 | O | | Off / Off / Off | Off / Off / Off | 7 | 1.8V / 3.3V | VDDSHV3 | Yes | LVC MOS | PU/PD |
| | | | FSI_RX5_CLK | 1 | I | 0 | | | | | | | | |
| | | | UART5_RXD | 2 | I | 1 | | | | | | | | |
| | | | EHRPWM_TZn_IN3 | 3 | I | 0 | | | | | | | | |
| | | | TRC_DATA15 | 6 | O | | | | | | | | | |
| | | | GPIO0_32 | 7 | IO | pad | | | | | | | | |
| | | | PRG0_PWM3_TZ_IN | 9 | I | 0 | | | | | | | | |

Table 5-1. Pin Attributes (ALV, ANI, ALX Packages) (continued)

| ALV ANI BALL NUMBER [1] | ALX BALL NUMBER [1] | BALL NAME [2] PADCONFIG Register [15] PADCONFIG Address [16] | SIGNAL NAME [3] | MUX MODE [4] | TYPE [5] | DSIS [6] | BALL STATE DURING RESET RX/TX/PULL [7] | BALL STATE AFTER RESET RX/TX/PULL [8] | MUX MODE AFTER RESET [9] | IO OPERATING VOLTAGE [10] | POWER [11] | HYS [12] | BUFFER TYPE [14] | Pull UP/DOWN TYPE [13] |
|-------------------------------------|------------------------------|--|-----------------|-----------------|-------------|-------------|---|--|--------------------------------------|---------------------------------|------------|-------------|---------------------|------------------------------|
| R17 | | GPMC0_CLK PADCONFIG: PADCONFIG31 0x000F407C | GPMC0_CLK | 0 | O | 0 | Off / Off / Off | Off / Off / Off | 7 | 1.8V / 3.3V | VDDSHV3 | Yes | LVCMOS | PU/PD |
| | | | FSI_RX4_CLK | 1 | I | 0 | | | | | | | | |
| | | | UART4_RTSn | 2 | O | | | | | | | | | |
| | | | EHRPWM3_SYNCO | 3 | O | | | | | | | | | |
| | | | GPMC0_FCLK_MUX | 4 | O | | | | | | | | | |
| | | | TRC_DATA14 | 6 | O | | | | | | | | | |
| | | | GPIO0_31 | 7 | IO | pad | | | | | | | | |
| PRG0_PWM3_TZ_OUT | 9 | O | | | | | | | | | | | | |
| N17 | | GPMC0_DIR PADCONFIG: PADCONFIG41 0x000F40A4 | GPMC0_DIR | 0 | O | | Off / Off / Off | Off / Off / Off | 7 | 1.8V / 3.3V | VDDSHV3 | Yes | LVCMOS | PU/PD |
| | | | EQEP0_B | 3 | I | 0 | | | | | | | | |
| | | | GPIO0_40 | 7 | IO | pad | | | | | | | | |
| | | | EHRPWM6_B | 8 | IO | 0 | | | | | | | | |
| | | | PRG1_PWM2_B0 | 9 | IO | 1 | | | | | | | | |
| R18 | | GPMC0_OEn_REn PADCONFIG: PADCONFIG34 0x000F4088 | GPMC0_OEn_REn | 0 | O | | Off / Off / Off | Off / Off / Off | 7 | 1.8V / 3.3V | VDDSHV3 | Yes | LVCMOS | PU/PD |
| | | | FSI_RX5_D0 | 1 | I | 0 | | | | | | | | |
| | | | UART5_TXD | 2 | O | | | | | | | | | |
| | | | EHRPWM4_A | 3 | IO | 0 | | | | | | | | |
| | | | TRC_DATA16 | 6 | O | | | | | | | | | |
| | | | GPIO0_33 | 7 | IO | pad | | | | | | | | |
| | | | PRG0_PWM3_A1 | 9 | IO | 0 | | | | | | | | |
| T21 | | GPMC0_WEn PADCONFIG: PADCONFIG35 0x000F408C | GPMC0_WEn | 0 | O | | Off / Off / Off | Off / Off / Off | 7 | 1.8V / 3.3V | VDDSHV3 | Yes | LVCMOS | PU/PD |
| | | | FSI_RX5_D1 | 1 | I | 0 | | | | | | | | |
| | | | UART5_RTSn | 2 | O | | | | | | | | | |
| | | | EHRPWM4_B | 3 | IO | 0 | | | | | | | | |
| | | | TRC_DATA17 | 6 | O | | | | | | | | | |
| | | | GPIO0_34 | 7 | IO | pad | | | | | | | | |
| | | | PRG0_PWM3_B1 | 9 | IO | 1 | | | | | | | | |
| N16 | | GPMC0_WPn PADCONFIG: PADCONFIG40 0x000F40A0 | GPMC0_WPn | 0 | O | | Off / Off / Off | Off / Off / Off | 7 | 1.8V / 3.3V | VDDSHV3 | Yes | LVCMOS | PU/PD |
| | | | FSI_TX1_CLK | 1 | O | | | | | | | | | |
| | | | EQEP0_A | 3 | I | 0 | | | | | | | | |
| | | | GPMC0_A22 | 4 | OZ | | | | | | | | | |
| | | | TRC_DATA22 | 6 | O | | | | | | | | | |
| | | | GPIO0_39 | 7 | IO | pad | | | | | | | | |
| | | | EHRPWM6_A | 8 | IO | 0 | | | | | | | | |
| | | | PRG1_PWM2_A0 | 9 | IO | 0 | | | | | | | | |

Table 5-1. Pin Attributes (ALV, ANI, ALX Packages) (continued)

| ALV ANI BALL NUMBER [1] | ALX BALL NUMBER [1] | BALL NAME [2] PADCONFIG Register [15] PADCONFIG Address [16] | SIGNAL NAME [3] | MUX MODE [4] | TYPE [5] | DSIS [6] | BALL STATE DURING RESET RX/TX/PULL [7] | BALL STATE AFTER RESET RX/TX/PULL [8] | MUX MODE AFTER RESET [9] | IO OPERATING VOLTAGE [10] | POWER [11] | HYS [12] | BUFFER TYPE [14] | Pull UP/DOWN TYPE [13] |
|-------------------------|---------------------|--|------------------|--------------|----------|----------|--|---------------------------------------|--------------------------|---------------------------|------------|----------|------------------|------------------------|
| T20 | R21 | GPMC0_AD0 PADCONFIG: PADCONFIG15 0x000F403C | GPMC0_AD0 | 0 | IO | 0 | On / Off / Off | On / Off / Off | 7 | 1.8V / 3.3V | VDDSHV3 | Yes | LVCMOS | PU/PD |
| | | | FSI_RX2_CLK | 1 | I | 0 | | | | | | | | |
| | | | UART2_RXD | 2 | I | 1 | | | | | | | | |
| | | | EHRPWM0_SYNCI | 3 | I | 0 | | | | | | | | |
| | | | TRC_CLK | 6 | O | | | | | | | | | |
| | | | GPIO0_15 | 7 | IO | pad | | | | | | | | |
| BOOTMODE00 | Bootstrap | I | | | | | | | | | | | | |
| U21 | R20 | GPMC0_AD1 PADCONFIG: PADCONFIG16 0x000F4040 | GPMC0_AD1 | 0 | IO | 0 | On / Off / Off | On / Off / Off | 7 | 1.8V / 3.3V | VDDSHV3 | Yes | LVCMOS | PU/PD |
| | | | FSI_RX2_D0 | 1 | I | 0 | | | | | | | | |
| | | | UART2_TXD | 2 | O | | | | | | | | | |
| | | | EHRPWM0_SYNCO | 3 | O | | | | | | | | | |
| | | | TRC_CTL | 6 | O | | | | | | | | | |
| | | | GPIO0_16 | 7 | IO | pad | | | | | | | | |
| | | | PRG0_PWM2_TZ_OUT | 9 | O | | | | | | | | | |
| BOOTMODE01 | Bootstrap | I | | | | | | | | | | | | |
| T18 | T19 | GPMC0_AD2 PADCONFIG: PADCONFIG17 0x000F4044 | GPMC0_AD2 | 0 | IO | 0 | On / Off / Off | On / Off / Off | 7 | 1.8V / 3.3V | VDDSHV3 | Yes | LVCMOS | PU/PD |
| | | | FSI_RX2_D1 | 1 | I | 0 | | | | | | | | |
| | | | UART2_RTSn | 2 | O | | | | | | | | | |
| | | | EHRPWM_TZn_IN0 | 3 | I | 0 | | | | | | | | |
| | | | TRC_DATA0 | 6 | O | | | | | | | | | |
| | | | GPIO0_17 | 7 | IO | pad | | | | | | | | |
| | | | PRG0_PWM2_TZ_IN | 9 | I | 0 | | | | | | | | |
| BOOTMODE02 | Bootstrap | I | | | | | | | | | | | | |
| U20 | V21 | GPMC0_AD3 PADCONFIG: PADCONFIG18 0x000F4048 | GPMC0_AD3 | 0 | IO | 0 | On / Off / Off | On / Off / Off | 7 | 1.8V / 3.3V | VDDSHV3 | Yes | LVCMOS | PU/PD |
| | | | FSI_RX3_CLK | 1 | I | 0 | | | | | | | | |
| | | | UART3_RXD | 2 | I | 1 | | | | | | | | |
| | | | EHRPWM0_A | 3 | IO | 0 | | | | | | | | |
| | | | TRC_DATA1 | 6 | O | | | | | | | | | |
| | | | GPIO0_18 | 7 | IO | pad | | | | | | | | |
| | | | PRG0_PWM2_A0 | 9 | IO | 0 | | | | | | | | |
| | | | BOOTMODE03 | Bootstrap | I | | | | | | | | | |

Table 5-1. Pin Attributes (ALV, ANI, ALX Packages) (continued)

| ALV ANI BALL NUMBER [1] | ALX BALL NUMBER [1] | BALL NAME [2] PADCONFIG Register [15] PADCONFIG Address [16] | SIGNAL NAME [3] | MUX MODE [4] | TYPE [5] | DSIS [6] | BALL STATE DURING RESET RX/TX/PULL [7] | BALL STATE AFTER RESET RX/TX/PULL [8] | MUX MODE AFTER RESET [9] | IO OPERATING VOLTAGE [10] | POWER [11] | HYS [12] | BUFFER TYPE [14] | Pull UP/DOWN TYPE [13] |
|-------------------------|---------------------|--|-----------------|--------------|----------|----------|--|---------------------------------------|--------------------------|---------------------------|------------|----------|------------------|------------------------|
| U18 | U21 | GPMC0_AD4 PADCONFIG: PADCONFIG19 0x000F404C | GPMC0_AD4 | 0 | IO | 0 | On / Off / Off | On / Off / Off | 7 | 1.8V / 3.3V | VDDSHV3 | Yes | LVCMOS | PU/PD |
| | | | FSI_RX3_D0 | 1 | I | 0 | | | | | | | | |
| | | | UART3_TXD | 2 | O | | | | | | | | | |
| | | | EHRPWM0_B | 3 | IO | 0 | | | | | | | | |
| | | | TRC_DATA2 | 6 | O | | | | | | | | | |
| | | | GPIO0_82 | 7 | IO | pad | | | | | | | | |
| | | | PRG0_PWM2_B0 | 9 | IO | 1 | | | | | | | | |
| BOOTMODE04 | Bootstrap | I | | | | | | | | | | | | |
| U19 | T20 | GPMC0_AD5 PADCONFIG: PADCONFIG20 0x000F4050 | GPMC0_AD5 | 0 | IO | 0 | On / Off / Off | On / Off / Off | 7 | 1.8V / 3.3V | VDDSHV3 | Yes | LVCMOS | PU/PD |
| | | | FSI_RX3_D1 | 1 | I | 0 | | | | | | | | |
| | | | UART3_RTSn | 2 | O | | | | | | | | | |
| | | | EHRPWM1_A | 3 | IO | 0 | | | | | | | | |
| | | | TRC_DATA3 | 6 | O | | | | | | | | | |
| | | | GPIO0_83 | 7 | IO | pad | | | | | | | | |
| | | | PRG0_PWM2_A1 | 9 | IO | 0 | | | | | | | | |
| BOOTMODE05 | Bootstrap | I | | | | | | | | | | | | |
| V20 | T18 | GPMC0_AD6 PADCONFIG: PADCONFIG21 0x000F4054 | GPMC0_AD6 | 0 | IO | 0 | On / Off / Off | On / Off / Off | 7 | 1.8V / 3.3V | VDDSHV3 | Yes | LVCMOS | PU/PD |
| | | | FSI_RX4_D0 | 1 | I | 0 | | | | | | | | |
| | | | UART4_RXD | 2 | I | 1 | | | | | | | | |
| | | | EHRPWM1_B | 3 | IO | 0 | | | | | | | | |
| | | | TRC_DATA4 | 6 | O | | | | | | | | | |
| | | | GPIO0_21 | 7 | IO | pad | | | | | | | | |
| | | | PRG0_PWM2_B1 | 9 | IO | 1 | | | | | | | | |
| BOOTMODE06 | Bootstrap | I | | | | | | | | | | | | |
| V21 | U19 | GPMC0_AD7 PADCONFIG: PADCONFIG22 0x000F4058 | GPMC0_AD7 | 0 | IO | 0 | On / Off / Off | On / Off / Off | 7 | 1.8V / 3.3V | VDDSHV3 | Yes | LVCMOS | PU/PD |
| | | | FSI_RX4_D1 | 1 | I | 0 | | | | | | | | |
| | | | UART4_TXD | 2 | O | | | | | | | | | |
| | | | EHRPWM_TZn_IN1 | 3 | I | 0 | | | | | | | | |
| | | | EHRPWM8_A | 4 | IO | 0 | | | | | | | | |
| | | | TRC_DATA5 | 6 | O | | | | | | | | | |
| | | | GPIO0_22 | 7 | IO | pad | | | | | | | | |
| PRG1_PWM2_A2 | 9 | IO | 0 | | | | | | | | | | | |
| BOOTMODE07 | Bootstrap | I | | | | | | | | | | | | |

Table 5-1. Pin Attributes (ALV, ANI, ALX Packages) (continued)

| ALV ANI BALL NUMBER [1] | ALX BALL NUMBER [1] | BALL NAME [2] PADCONFIG Register [15] PADCONFIG Address [16] | SIGNAL NAME [3] | MUX MODE [4] | TYPE [5] | DSIS [6] | BALL STATE DURING RESET RX/TX/PULL [7] | BALL STATE AFTER RESET RX/TX/PULL [8] | MUX MODE AFTER RESET [9] | IO OPERATING VOLTAGE [10] | POWER [11] | HYS [12] | BUFFER TYPE [14] | Pull UP/DOWN TYPE [13] |
|-------------------------------------|------------------------------|--|-----------------|-----------------|-------------|-------------|---|--|--------------------------------------|---------------------------------|------------|-------------|---------------------|------------------------------|
| V19 | U18 | GPMC0_AD8 PADCONFIG: PADCONFIG23 0x000F405C | GPMC0_AD8 | 0 | IO | 0 | On / Off / Off | On / Off / Off | 7 | 1.8V / 3.3V | VDDSHV3 | Yes | LVCMOS | PU/PD |
| | | | FSI_RX0_CLK | 1 | I | 0 | | | | | | | | |
| | | | UART2_CTSn | 2 | I | 1 | | | | | | | | |
| | | | EHRPWM2_A | 3 | IO | 0 | | | | | | | | |
| | | | TRC_DATA6 | 6 | O | | | | | | | | | |
| | | | GPIO0_23 | 7 | IO | pad | | | | | | | | |
| | | | PRG0_PWM2_A2 | 9 | IO | 0 | | | | | | | | |
| BOOTMODE08 | Bootstrap | I | | | | | | | | | | | | |
| T17 | U20 | GPMC0_AD9 PADCONFIG: PADCONFIG24 0x000F4060 | GPMC0_AD9 | 0 | IO | 0 | On / Off / Off | On / Off / Off | 7 | 1.8V / 3.3V | VDDSHV3 | Yes | LVCMOS | PU/PD |
| | | | FSI_RX0_D0 | 1 | I | 0 | | | | | | | | |
| | | | UART3_CTSn | 2 | I | 1 | | | | | | | | |
| | | | EHRPWM2_B | 3 | IO | 0 | | | | | | | | |
| | | | TRC_DATA7 | 6 | O | | | | | | | | | |
| | | | GPIO0_24 | 7 | IO | pad | | | | | | | | |
| | | | PRG0_PWM2_B2 | 9 | IO | 1 | | | | | | | | |
| BOOTMODE09 | Bootstrap | I | | | | | | | | | | | | |
| R16 | V20 | GPMC0_AD10 PADCONFIG: PADCONFIG25 0x000F4064 | GPMC0_AD10 | 0 | IO | 0 | On / Off / Off | On / Off / Off | 7 | 1.8V / 3.3V | VDDSHV3 | Yes | LVCMOS | PU/PD |
| | | | FSI_RX0_D1 | 1 | I | 0 | | | | | | | | |
| | | | UART4_CTSn | 2 | I | 1 | | | | | | | | |
| | | | EHRPWM_TZn_IN2 | 3 | I | 0 | | | | | | | | |
| | | | EHRPWM8_B | 4 | IO | 0 | | | | | | | | |
| | | | TRC_DATA8 | 6 | O | | | | | | | | | |
| | | | GPIO0_25 | 7 | IO | pad | | | | | | | | |
| PRG1_PWM2_B2 | 9 | IO | 1 | | | | | | | | | | | |
| BOOTMODE10 | Bootstrap | I | | | | | | | | | | | | |
| W20 | W20 | GPMC0_AD11 PADCONFIG: PADCONFIG26 0x000F4068 | GPMC0_AD11 | 0 | IO | 0 | On / Off / Off | On / Off / Off | 7 | 1.8V / 3.3V | VDDSHV3 | Yes | LVCMOS | PU/PD |
| | | | FSI_RX1_CLK | 1 | I | 0 | | | | | | | | |
| | | | UART5_CTSn | 2 | I | 1 | | | | | | | | |
| | | | EQEP1_A | 3 | I | 0 | | | | | | | | |
| | | | TRC_DATA9 | 6 | O | | | | | | | | | |
| | | | GPIO0_26 | 7 | IO | pad | | | | | | | | |
| | | | EHRPWM7_A | 8 | IO | 0 | | | | | | | | |
| BOOTMODE11 | Bootstrap | I | | | | | | | | | | | | |

Table 5-1. Pin Attributes (ALV, ANI, ALX Packages) (continued)

| ALV ANI BALL NUMBER [1] | ALX BALL NUMBER [1] | BALL NAME [2] PADCONFIG Register [15] PADCONFIG Address [16] | SIGNAL NAME [3] | MUX MODE [4] | TYPE [5] | DSIS [6] | BALL STATE DURING RESET RX/TX/PULL [7] | BALL STATE AFTER RESET RX/TX/PULL [8] | MUX MODE AFTER RESET [9] | IO OPERATING VOLTAGE [10] | POWER [11] | HYS [12] | BUFFER TYPE [14] | Pull UP/DOWN TYPE [13] |
|-------------------------|---------------------|--|-----------------|--------------|----------|----------|--|---------------------------------------|--------------------------|---------------------------|------------|----------|------------------|------------------------|
| W21 | Y20 | GPMC0_AD12 PADCONFIG: PADCONFIG27 0x000F406C | GPMC0_AD12 | 0 | IO | 0 | On / Off / Off | On / Off / Off | 7 | 1.8V / 3.3V | VDDSHV3 | Yes | LVCMOS | PU/PD |
| | | | FSI_RX1_D0 | 1 | I | 0 | | | | | | | | |
| | | | UART6_CTSn | 2 | I | 1 | | | | | | | | |
| | | | EQEP1_B | 3 | I | 0 | | | | | | | | |
| | | | TRC_DATA10 | 6 | O | | | | | | | | | |
| | | | GPIO0_27 | 7 | IO | pad | | | | | | | | |
| | | | EHRPWM7_B | 8 | IO | 0 | | | | | | | | |
| BOOTMODE12 | Bootstrap | I | | | | | | | | | | | | |
| V18 | Y19 | GPMC0_AD13 PADCONFIG: PADCONFIG28 0x000F4070 | GPMC0_AD13 | 0 | IO | 0 | On / Off / Off | On / Off / Off | 7 | 1.8V / 3.3V | VDDSHV3 | Yes | LVCMOS | PU/PD |
| | | | FSI_RX1_D1 | 1 | I | 0 | | | | | | | | |
| | | | EHRPWM3_A | 3 | IO | 0 | | | | | | | | |
| | | | TRC_DATA11 | 6 | O | | | | | | | | | |
| | | | GPIO0_28 | 7 | IO | pad | | | | | | | | |
| | | | PRG0_PWM3_A0 | 9 | IO | 0 | | | | | | | | |
| | | | BOOTMODE13 | Bootstrap | I | | | | | | | | | |
| Y21 | Y18 | GPMC0_AD14 PADCONFIG: PADCONFIG29 0x000F4074 | GPMC0_AD14 | 0 | IO | 0 | On / Off / Off | On / Off / Off | 7 | 1.8V / 3.3V | VDDSHV3 | Yes | LVCMOS | PU/PD |
| | | | FSI_TX0_D0 | 1 | O | | | | | | | | | |
| | | | UART6_RXD | 2 | I | 1 | | | | | | | | |
| | | | EHRPWM3_B | 3 | IO | 0 | | | | | | | | |
| | | | TRC_DATA12 | 6 | O | | | | | | | | | |
| | | | GPIO0_29 | 7 | IO | pad | | | | | | | | |
| | | | PRG0_PWM3_B0 | 9 | IO | 1 | | | | | | | | |
| BOOTMODE14 | Bootstrap | I | | | | | | | | | | | | |
| Y20 | AA19 | GPMC0_AD15 PADCONFIG: PADCONFIG30 0x000F4078 | GPMC0_AD15 | 0 | IO | 0 | On / Off / Off | On / Off / Off | 7 | 1.8V / 3.3V | VDDSHV3 | Yes | LVCMOS | PU/PD |
| | | | FSI_TX0_D1 | 1 | O | | | | | | | | | |
| | | | UART6_TXD | 2 | O | | | | | | | | | |
| | | | EHRPWM3_SYNCI | 3 | I | 0 | | | | | | | | |
| | | | TRC_DATA13 | 6 | O | | | | | | | | | |
| | | | GPIO0_30 | 7 | IO | pad | | | | | | | | |
| | | | BOOTMODE15 | Bootstrap | I | | | | | | | | | |

Table 5-1. Pin Attributes (ALV, ANI, ALX Packages) (continued)

| ALV ANI BALL NUMBER [1] | ALX BALL NUMBER [1] | BALL NAME [2] PADCONFIG Register [15] PADCONFIG Address [16] | SIGNAL NAME [3] | MUX MODE [4] | TYPE [5] | DSIS [6] | BALL STATE DURING RESET RX/TX/PULL [7] | BALL STATE AFTER RESET RX/TX/PULL [8] | MUX MODE AFTER RESET [9] | IO OPERATING VOLTAGE [10] | POWER [11] | HYS [12] | BUFFER TYPE [14] | Pull UP/DOWN TYPE [13] |
|-------------------------|---------------------|--|------------------|--------------|----------|----------|--|---------------------------------------|--------------------------|---------------------------|------------|----------|------------------|------------------------|
| P17 | | GPMC0_BE0n_CLE PADCONFIG: PADCONFIG36 0x000F4090 | GPMC0_BE0n_CLE | 0 | O | | Off / Off / Off | Off / Off / Off | 7 | 1.8V / 3.3V | VDDSHV3 | Yes | LVCMOS | PU/PD |
| | | | FSI_TX1_D0 | 1 | O | | | | | | | | | |
| | | | UART6_RTSn | 2 | O | | | | | | | | | |
| | | | EHRPWM_TZn_IN4 | 3 | I | 0 | | | | | | | | |
| | | | EHRPWM7_A | 5 | IO | 0 | | | | | | | | |
| | | | TRC_DATA18 | 6 | O | | | | | | | | | |
| | | | GPIO0_35 | 7 | IO | pad | | | | | | | | |
| PRG1_PWM2_A1 | 9 | IO | 0 | | | | | | | | | | | |
| T19 | P21 | GPMC0_BE1n PADCONFIG: PADCONFIG37 0x000F4094 | GPMC0_BE1n | 0 | O | | Off / Off / Off | Off / Off / Off | 7 | 1.8V / 3.3V | VDDSHV3 | Yes | LVCMOS | PU/PD |
| | | | FSI_TX0_CLK | 1 | O | | | | | | | | | |
| | | | EHRPWM5_A | 3 | IO | 0 | | | | | | | | |
| | | | TRC_DATA19 | 6 | O | | | | | | | | | |
| | | | GPIO0_36 | 7 | IO | pad | | | | | | | | |
| | | | PRG0_PWM3_A2 | 9 | IO | 0 | | | | | | | | |
| R19 | | GPMC0_CSn0 PADCONFIG: PADCONFIG42 0x000F40A8 | GPMC0_CSn0 | 0 | O | | Off / Off / Off | Off / Off / Off | 7 | 1.8V / 3.3V | VDDSHV3 | Yes | LVCMOS | PU/PD |
| | | | EQEP0_S | 3 | IO | 0 | | | | | | | | |
| | | | TRC_DATA23 | 6 | O | | | | | | | | | |
| | | | GPIO0_41 | 7 | IO | pad | | | | | | | | |
| | | | EHRPWM6_SYNCI | 8 | I | 0 | | | | | | | | |
| R20 | | GPMC0_CSn1 PADCONFIG: PADCONFIG43 0x000F40AC | GPMC0_CSn1 | 0 | O | | Off / Off / Off | Off / Off / Off | 7 | 1.8V / 3.3V | VDDSHV3 | Yes | LVCMOS | PU/PD |
| | | | EQEP0_I | 3 | IO | 0 | | | | | | | | |
| | | | EHRPWM_TZn_IN2 | 5 | I | 0 | | | | | | | | |
| | | | GPIO0_42 | 7 | IO | pad | | | | | | | | |
| | | | EHRPWM6_SYNCO | 8 | O | | | | | | | | | |
| | | | PRG1_PWM2_TZ_OUT | 9 | O | | | | | | | | | |
| P19 | | GPMC0_CSn2 PADCONFIG: PADCONFIG44 0x000F40B0 | GPMC0_CSn2 | 0 | O | | Off / Off / Off | Off / Off / Off | 7 | 1.8V / 3.3V | VDDSHV3 | Yes | LVCMOS | PU/PD |
| | | | I2C2_SCL | 1 | IOD | 1 | | | | | | | | |
| | | | TIMER_IO8 | 2 | IO | 0 | | | | | | | | |
| | | | EQEP1_S | 3 | IO | 0 | | | | | | | | |
| | | | EHRPWM_TZn_IN4 | 5 | I | 0 | | | | | | | | |
| | | | GPIO0_43 | 7 | IO | pad | | | | | | | | |
| | | | PRG1_PWM2_TZ_IN | 9 | I | 0 | | | | | | | | |

Table 5-1. Pin Attributes (ALV, ANI, ALX Packages) (continued)

| ALV ANI BALL NUMBER [1] | ALX BALL NUMBER [1] | BALL NAME [2] PADCONFIG Register [15] PADCONFIG Address [16] | SIGNAL NAME [3] | MUX MODE [4] | TYPE [5] | DSIS [6] | BALL STATE DURING RESET RX/TX/PULL [7] | BALL STATE AFTER RESET RX/TX/PULL [8] | MUX MODE AFTER RESET [9] | IO OPERATING VOLTAGE [10] | POWER [11] | HYS [12] | BUFFER TYPE [14] | Pull UP/DOWN TYPE [13] | |
|-------------------------|---------------------|--|-----------------|--------------|----------|----------|--|---------------------------------------|--------------------------|---------------------------|------------|----------|------------------|------------------------|--|
| R21 | | GPMC0_CSn3 PADCONFIG: PADCONFIG45 0x000F40B4 | GPMC0_CSn3 | 0 | O | | Off / Off / Off | Off / Off / Off | 7 | 1.8V / 3.3V | VDDSHV3 | Yes | LVC MOS | PU/PD | |
| | | | I2C2_SDA | 1 | IOD | 1 | | | | | | | | | |
| | | | TIMER_IO9 | 2 | IO | 0 | | | | | | | | | |
| | | | EQEP1_I | 3 | IO | 0 | | | | | | | | | |
| | | | GPMC0_A20 | 4 | OZ | | | | | | | | | | |
| | | | EHRPWM_TZn_IN5 | 5 | I | 0 | | | | | | | | | |
| | | | GPIO0_44 | 7 | IO | pad | | | | | | | | | |
| W19 | | GPMC0_WAIT0 PADCONFIG: PADCONFIG38 0x000F4098 | GPMC0_WAIT0 | 0 | I | 1 | Off / Off / Off | Off / Off / Off | 7 | 1.8V / 3.3V | VDDSHV3 | Yes | LVC MOS | PU/PD | |
| | | | EHRPWM5_B | 3 | IO | 0 | | | | | | | | | |
| | | | TRC_DATA20 | 6 | O | | | | | | | | | | |
| | | | GPIO0_37 | 7 | IO | pad | | | | | | | | | |
| | | | PRG0_PWM3_B2 | 9 | IO | 1 | | | | | | | | | |
| Y18 | | GPMC0_WAIT1 PADCONFIG: PADCONFIG39 0x000F409C | GPMC0_WAIT1 | 0 | I | 1 | Off / Off / Off | Off / Off / Off | 7 | 1.8V / 3.3V | VDDSHV3 | Yes | LVC MOS | PU/PD | |
| | | | FSI_TX1_D1 | 1 | O | | | | | | | | | | |
| | | | EHRPWM_TZn_IN5 | 3 | I | 0 | | | | | | | | | |
| | | | GPMC0_A21 | 4 | OZ | | | | | | | | | | |
| | | | EHRPWM7_B | 5 | IO | 0 | | | | | | | | | |
| | | | TRC_DATA21 | 6 | O | | | | | | | | | | |
| | | | GPIO0_38 | 7 | IO | pad | | | | | | | | | |
| | | | PRG1_PWM2_B1 | 9 | IO | 1 | | | | | | | | | |
| A18 | B16 | I2C0_SCL PADCONFIG: PADCONFIG152 0x000F4260 | I2C0_SCL | 0 | IOD | 1 | Off / Off / NA | On / SS / NA | 7 | 1.8V / 3.3V | VDDSHV0 | Yes | I2C OD FS | | |
| | | | GPIO1_64 | 7 | IOD | pad | | | | | | | | | |
| B18 | B15 | I2C0_SDA PADCONFIG: PADCONFIG153 0x000F4264 | I2C0_SDA | 0 | IOD | 1 | Off / Off / NA | On / SS / NA | 7 | 1.8V / 3.3V | VDDSHV0 | Yes | I2C OD FS | | |
| | | | GPIO1_65 | 7 | IOD | pad | | | | | | | | | |
| C18 | A17 | I2C1_SCL PADCONFIG: PADCONFIG154 0x000F4268 | I2C1_SCL | 0 | IOD | 1 | Off / Off / Off | Off / Off / Off | 7 | 1.8V / 3.3V | VDDSHV0 | Yes | LVC MOS | PU/PD | |
| | | | CPTS0_HW1TSPUSH | 1 | I | 0 | | | | | | | | | |
| | | | TIMER_IO0 | 2 | IO | 0 | | | | | | | | | |
| | | | SPI2_CS1 | 3 | IO | 1 | | | | | | | | | |
| | | | GPIO1_66 | 7 | IO | pad | | | | | | | | | |
| B19 | B18 | I2C1_SDA PADCONFIG: PADCONFIG155 0x000F426C | I2C1_SDA | 0 | IOD | 1 | Off / Off / Off | Off / Off / Off | 7 | 1.8V / 3.3V | VDDSHV0 | Yes | LVC MOS | PU/PD | |
| | | | CPTS0_HW2TSPUSH | 1 | I | 0 | | | | | | | | | |
| | | | TIMER_IO1 | 2 | IO | 0 | | | | | | | | | |
| | | | SPI2_CS2 | 3 | IO | 1 | | | | | | | | | |
| | | | GPIO1_67 | 7 | IO | pad | | | | | | | | | |

Table 5-1. Pin Attributes (ALV, ANI, ALX Packages) (continued)

| ALV ANI BALL NUMBER [1] | ALX BALL NUMBER [1] | BALL NAME [2] PADCONFIG Register [15] PADCONFIG Address [16] | SIGNAL NAME [3] | MUX MODE [4] | TYPE [5] | DSIS [6] | BALL STATE DURING RESET RX/TX/PULL [7] | BALL STATE AFTER RESET RX/TX/PULL [8] | MUX MODE AFTER RESET [9] | IO OPERATING VOLTAGE [10] | POWER [11] | HYS [12] | BUFFER TYPE [14] | Pull UP/DOWN TYPE [13] |
|-------------------------|---------------------|--|-------------------|--------------|----------|----------|--|---------------------------------------|--------------------------|---------------------------|------------|----------|------------------|------------------------|
| B17 | A14 | MCAN0_RX PADCONFIG: PADCONFIG149 0x000F4254 | MCAN0_RX | 0 | I | 1 | Off / Off / Off | Off / Off / Off | 7 | 1.8V / 3.3V | VDDSHV0 | Yes | LVCMOS | PU/PD |
| | | | UART4_TXD | 1 | O | | | | | | | | | |
| | | | TIMER_IO3 | 2 | IO | 0 | | | | | | | | |
| | | | SYNC3_OUT | 3 | O | | | | | | | | | |
| | | | SPI4_CS2 | 6 | IO | 1 | | | | | | | | |
| | | | GPIO1_61 | 7 | IO | pad | | | | | | | | |
| | | | EQEP2_S | 8 | IO | 0 | | | | | | | | |
| UART0_RIn | 9 | I | 1 | | | | | | | | | | | |
| A17 | B13 | MCAN0_TX PADCONFIG: PADCONFIG148 0x000F4250 | MCAN0_TX | 0 | O | | Off / Off / Off | Off / Off / Off | 7 | 1.8V / 3.3V | VDDSHV0 | Yes | LVCMOS | PU/PD |
| | | | UART4_RXD | 1 | I | 1 | | | | | | | | |
| | | | TIMER_IO2 | 2 | IO | 0 | | | | | | | | |
| | | | SYNC2_OUT | 3 | O | | | | | | | | | |
| | | | SPI4_CS1 | 6 | IO | 1 | | | | | | | | |
| | | | GPIO1_60 | 7 | IO | pad | | | | | | | | |
| | | | EQEP2_I | 8 | IO | 0 | | | | | | | | |
| UART0_DTRn | 9 | O | | | | | | | | | | | | |
| D17 | A15 | MCAN1_RX PADCONFIG: PADCONFIG151 0x000F425C | MCAN1_RX | 0 | I | 1 | Off / Off / Off | Off / Off / Off | 7 | 1.8V / 3.3V | VDDSHV0 | Yes | LVCMOS | PU/PD |
| | | | I2C3_SDA | 1 | IOD | 1 | | | | | | | | |
| | | | ECAP2_IN_APWM_OUT | 2 | IO | 0 | | | | | | | | |
| | | | OBSCLK0 | 3 | O | | | | | | | | | |
| | | | TIMER_IO5 | 4 | IO | 0 | | | | | | | | |
| | | | UART5_TXD | 5 | O | | | | | | | | | |
| | | | EHRPWM_SOCB | 6 | O | | | | | | | | | |
| | | | GPIO1_63 | 7 | IO | pad | | | | | | | | |
| | | | EQEP2_B | 8 | I | 0 | | | | | | | | |
| | | | UART0_DSRn | 9 | I | 1 | | | | | | | | |
| OBSCLK0 | 15 | O | | | | | | | | | | | | |

Table 5-1. Pin Attributes (ALV, ANI, ALX Packages) (continued)

| ALV ANI BALL NUMBER [1] | ALX BALL NUMBER [1] | BALL NAME [2] PADCONFIG Register [15] PADCONFIG Address [16] | SIGNAL NAME [3] | MUX MODE [4] | TYPE [5] | DSIS [6] | BALL STATE DURING RESET RX/TX/PULL [7] | BALL STATE AFTER RESET RX/TX/PULL [8] | MUX MODE AFTER RESET [9] | IO OPERATING VOLTAGE [10] | POWER [11] | HYS [12] | BUFFER TYPE [14] | Pull UP/DOWN TYPE [13] | |
|-------------------------|---------------------|--|-------------------|--------------|----------|----------|--|---------------------------------------|--------------------------|---------------------------|------------|----------|------------------|------------------------|--|
| C17 | B14 | MCAN1_TX PADCONFIG: PADCONFIG150 0x000F4258 | MCAN1_TX | 0 | O | | Off / Off / Off | Off / Off / Off | 7 | 1.8V / 3.3V | VDDSHV0 | Yes | LVC MOS | PU/PD | |
| | | | I2C3_SCL | 1 | IOD | 1 | | | | | | | | | |
| | | | ECAP1_IN_APWM_OUT | 2 | IO | 0 | | | | | | | | | |
| | | | SYSCLKOUT0 | 3 | O | | | | | | | | | | |
| | | | TIMER_IO4 | 4 | IO | 0 | | | | | | | | | |
| | | | UART5_RXD | 5 | I | 1 | | | | | | | | | |
| | | | EHRPWM_SOCA | 6 | O | | | | | | | | | | |
| | | | GPIO1_62 | 7 | IO | pad | | | | | | | | | |
| | | | EQEP2_A | 8 | I | 0 | | | | | | | | | |
| | | UART0_DCDn | 9 | I | 1 | | | | | | | | | | |
| E9 | | MCU_I2C0_SCL PADCONFIG: MCU_PADCONFIG18 0x04084048 | MCU_I2C0_SCL | 0 | IOD | 1 | Off / Off / NA | On / SS / NA | 7 | 1.8V / 3.3V | VDDSHV_MCU | Yes | I2C OD FS | | |
| | | | MCU_GPIO0_18 | 7 | IOD | pad | | | | | | | | | |
| A10 | | MCU_I2C0_SDA PADCONFIG: MCU_PADCONFIG19 0x0408404C | MCU_I2C0_SDA | 0 | IOD | 1 | Off / Off / NA | On / SS / NA | 7 | 1.8V / 3.3V | VDDSHV_MCU | Yes | I2C OD FS | | |
| | | | MCU_GPIO0_19 | 7 | IOD | pad | | | | | | | | | |
| A11 | | MCU_I2C1_SCL PADCONFIG: MCU_PADCONFIG20 0x04084050 | MCU_I2C1_SCL | 0 | IOD | 1 | Off / Off / Off | Off / Off / Off | 7 | 1.8V / 3.3V | VDDSHV_MCU | Yes | LVC MOS | PU/PD | |
| | | | MCU_GPIO0_20 | 7 | IO | pad | | | | | | | | | |
| B10 | | MCU_I2C1_SDA PADCONFIG: MCU_PADCONFIG21 0x04084054 | MCU_I2C1_SDA | 0 | IOD | 1 | Off / Off / Off | Off / Off / Off | 7 | 1.8V / 3.3V | VDDSHV_MCU | Yes | LVC MOS | PU/PD | |
| | | | MCU_GPIO0_21 | 7 | IO | pad | | | | | | | | | |
| C21 | D20 | MCU_OSC0_XI | MCU_OSC0_XI | | I | | | | | 1.8V | VDDS_OSC | Yes | HFOSC | | |
| B20 | C21 | MCU_OSC0_XO | MCU_OSC0_XO | | O | | | | | 1.8V | VDDS_OSC | Yes | HFOSC | | |
| B21 | C20 | MCU_PORz PADCONFIG: MCU_PADCONFIG23 0x0408405C | MCU_PORz | 0 | I | | | | 0 | 1.8V | VDDS_OSC | Yes | FS RESET | | |
| B13 | A6 | MCU_RESETSTATz PADCONFIG: MCU_PADCONFIG24 0x04084060 | MCU_RESETSTATz | 0 | O | | Off / Low / Off | Off / SS / Off | 0 | 1.8V / 3.3V | VDDSHV_MCU | Yes | LVC MOS | PU/PD | |
| | | | MCU_GPIO0_22 | 7 | IO | pad | | | | | | | | | |
| B12 | A5 | MCU_RESETz PADCONFIG: MCU_PADCONFIG22 0x04084058 | MCU_RESETz | 0 | I | | On / Off / Up | On / Off / Up | 0 | 1.8V / 3.3V | VDDSHV_MCU | Yes | LVC MOS | PU/PD | |

Table 5-1. Pin Attributes (ALV, ANI, ALX Packages) (continued)

| ALV ANI BALL NUMBER [1] | ALX BALL NUMBER [1] | BALL NAME [2] PADCONFIG Register [15] PADCONFIG Address [16] | SIGNAL NAME [3] | MUX MODE [4] | TYPE [5] | DSIS [6] | BALL STATE DURING RESET RX/TX/PULL [7] | BALL STATE AFTER RESET RX/TX/PULL [8] | MUX MODE AFTER RESET [9] | IO OPERATING VOLTAGE [10] | POWER [11] | HYS [12] | BUFFER TYPE [14] | Pull UP/DOWN TYPE [13] |
|-------------------------------------|------------------------------|--|-------------------|-----------------|-------------|-------------|---|--|--------------------------------------|---------------------------------|------------|-------------|---------------------|------------------------------|
| A20 | B20 | MCU_SAFETY_ERRORn PADCONFIG: MCU_PADCONFIG25 0x04084064 | MCU_SAFETY_ERRORn | 0 | IO | | Off / Off / Down | On / SS / Down | 0 | 1.8V | VDD5_OSC | Yes | LVC MOS | PU/PD |
| E6 | | MCU_SPI0_CLK PADCONFIG: MCU_PADCONFIG2 0x04084008 | MCU_SPI0_CLK | 0 | IO | 0 | Off / Off / Off | Off / Off / Off | 7 | 1.8V / 3.3V | VDDSHV_MCU | Yes | LVC MOS | PU/PD |
| | | | MCU_GPIO0_11 | 7 | IO | pad | | | | | | | | |
| D7 | | MCU_SPI1_CLK PADCONFIG: MCU_PADCONFIG7 0x0408401C | MCU_SPI1_CLK | 0 | IO | 0 | Off / Off / Off | Off / Off / Off | 7 | 1.8V / 3.3V | VDDSHV_MCU | Yes | LVC MOS | PU/PD |
| | | | MCU_GPIO0_7 | 7 | IO | pad | | | | | | | | |
| D6 | | MCU_SPI0_CS0 PADCONFIG: MCU_PADCONFIG0 0x04084000 | MCU_SPI0_CS0 | 0 | IO | 1 | Off / Off / Off | Off / Off / Off | 7 | 1.8V / 3.3V | VDDSHV_MCU | Yes | LVC MOS | PU/PD |
| | | | MCU_GPIO0_13 | 7 | IO | pad | | | | | | | | |
| C6 | | MCU_SPI0_CS1 PADCONFIG: MCU_PADCONFIG1 0x04084004 | MCU_SPI0_CS1 | 0 | IO | 1 | Off / Off / Off | Off / Off / Off | 7 | 1.8V / 3.3V | VDDSHV_MCU | Yes | LVC MOS | PU/PD |
| | | | MCU_OBSCLK0 | 1 | O | | | | | | | | | |
| | | | MCU_SYSCLKOUT0 | 2 | O | | | | | | | | | |
| | | | MCU_GPIO0_12 | 7 | IO | pad | | | | | | | | |
| E7 | | MCU_SPI0_D0 PADCONFIG: MCU_PADCONFIG3 0x0408400C | MCU_SPI0_D0 | 0 | IO | 0 | Off / Off / Off | Off / Off / Off | 7 | 1.8V / 3.3V | VDDSHV_MCU | Yes | LVC MOS | PU/PD |
| | | | MCU_GPIO0_10 | 7 | IO | pad | | | | | | | | |
| B6 | | MCU_SPI0_D1 PADCONFIG: MCU_PADCONFIG4 0x04084010 | MCU_SPI0_D1 | 0 | IO | 0 | Off / Off / Off | Off / Off / Off | 7 | 1.8V / 3.3V | VDDSHV_MCU | Yes | LVC MOS | PU/PD |
| | | | MCU_GPIO0_4 | 7 | IO | pad | | | | | | | | |
| A7 | | MCU_SPI1_CS0 PADCONFIG: MCU_PADCONFIG5 0x04084014 | MCU_SPI1_CS0 | 0 | IO | 1 | Off / Off / Off | Off / Off / Off | 7 | 1.8V / 3.3V | VDDSHV_MCU | Yes | LVC MOS | PU/PD |
| | | | MCU_GPIO0_5 | 7 | IO | pad | | | | | | | | |
| B7 | | MCU_SPI1_CS1 PADCONFIG: MCU_PADCONFIG6 0x04084018 | MCU_SPI1_CS1 | 0 | IO | 1 | Off / Off / Off | Off / Off / Off | 7 | 1.8V / 3.3V | VDDSHV_MCU | Yes | LVC MOS | PU/PD |
| | | | MCU_EXT_REFCLK0 | 1 | I | 0 | | | | | | | | |
| | | | MCU_GPIO0_6 | 7 | IO | pad | | | | | | | | |
| C7 | | MCU_SPI1_D0 PADCONFIG: MCU_PADCONFIG8 0x04084020 | MCU_SPI1_D0 | 0 | IO | 0 | Off / Off / Off | Off / Off / Off | 7 | 1.8V / 3.3V | VDDSHV_MCU | Yes | LVC MOS | PU/PD |
| | | | MCU_GPIO0_8 | 7 | IO | pad | | | | | | | | |
| C8 | | MCU_SPI1_D1 PADCONFIG: MCU_PADCONFIG9 0x04084024 | MCU_SPI1_D1 | 0 | IO | 0 | Off / Off / Off | Off / Off / Off | 7 | 1.8V / 3.3V | VDDSHV_MCU | Yes | LVC MOS | PU/PD |
| | | | MCU_GPIO0_9 | 7 | IO | pad | | | | | | | | |

Table 5-1. Pin Attributes (ALV, ANI, ALX Packages) (continued)

| ALV ANI BALL NUMBER [1] | ALX BALL NUMBER [1] | BALL NAME [2] PADCONFIG Register [15] PADCONFIG Address [16] | SIGNAL NAME [3] | MUX MODE [4] | TYPE [5] | DSIS [6] | BALL STATE DURING RESET RX/TX/PULL [7] | BALL STATE AFTER RESET RX/TX/PULL [8] | MUX MODE AFTER RESET [9] | IO OPERATING VOLTAGE [10] | POWER [11] | HYS [12] | BUFFER TYPE [14] | Pull UP/DOWN TYPE [13] |
|-------------------------------------|------------------------------|--|-----------------|-----------------|-------------|-------------|---|--|--------------------------------------|---------------------------------|------------|-------------|---------------------|------------------------------|
| D8 | D4 | MCU_UART0_CTSn PADCONFIG: MCU_PADCONFIG12 0x04084030 | MCU_UART0_CTSn | 0 | I | 1 | Off / Off / Off | Off / Off / Off | 7 | 1.8V / 3.3V | VDDSHV_MCU | Yes | LVCMOS | PU/PD |
| | | | MCU_TIMER_IO0 | 1 | IO | 0 | | | | | | | | |
| | | | MCU_SPI0_CS2 | 2 | IO | 1 | | | | | | | | |
| | | | MCU_GPIO0_1 | 7 | IO | pad | | | | | | | | |
| E8 | C2 | MCU_UART0_RTSn PADCONFIG: MCU_PADCONFIG13 0x04084034 | MCU_UART0_RTSn | 0 | O | | Off / Off / Off | Off / Off / Off | 7 | 1.8V / 3.3V | VDDSHV_MCU | Yes | LVCMOS | PU/PD |
| | | | MCU_TIMER_IO1 | 1 | IO | 0 | | | | | | | | |
| | | | MCU_SPI1_CS2 | 2 | IO | 1 | | | | | | | | |
| | | | MCU_GPIO0_0 | 7 | IO | pad | | | | | | | | |
| A9 | D6 | MCU_UART0_RXD PADCONFIG: MCU_PADCONFIG10 0x04084028 | MCU_UART0_RXD | 0 | I | 1 | Off / Off / Off | Off / Off / Off | 7 | 1.8V / 3.3V | VDDSHV_MCU | Yes | LVCMOS | PU/PD |
| | | | MCU_GPIO0_3 | 7 | IO | pad | | | | | | | | |
| A8 | B2 | MCU_UART0_TXD PADCONFIG: MCU_PADCONFIG11 0x0408402C | MCU_UART0_TXD | 0 | O | | Off / Off / Off | Off / Off / Off | 7 | 1.8V / 3.3V | VDDSHV_MCU | Yes | LVCMOS | PU/PD |
| | | | MCU_GPIO0_2 | 7 | IO | pad | | | | | | | | |
| B8 | | MCU_UART1_CTSn PADCONFIG: MCU_PADCONFIG16 0x04084040 | MCU_UART1_CTSn | 0 | I | 1 | Off / Off / Off | Off / Off / Off | 7 | 1.8V / 3.3V | VDDSHV_MCU | Yes | LVCMOS | PU/PD |
| | | | MCU_TIMER_IO2 | 1 | IO | 0 | | | | | | | | |
| | | | MCU_SPI0_CS3 | 2 | IO | 1 | | | | | | | | |
| | | | MCU_GPIO0_16 | 7 | IO | pad | | | | | | | | |
| B9 | | MCU_UART1_RTSn PADCONFIG: MCU_PADCONFIG17 0x04084044 | MCU_UART1_RTSn | 0 | O | | Off / Off / Off | Off / Off / Off | 7 | 1.8V / 3.3V | VDDSHV_MCU | Yes | LVCMOS | PU/PD |
| | | | MCU_TIMER_IO3 | 1 | IO | 0 | | | | | | | | |
| | | | MCU_SPI1_CS3 | 2 | IO | 1 | | | | | | | | |
| | | | MCU_GPIO0_17 | 7 | IO | pad | | | | | | | | |
| C9 | | MCU_UART1_RXD PADCONFIG: MCU_PADCONFIG14 0x04084038 | MCU_UART1_RXD | 0 | I | 1 | Off / Off / Off | Off / Off / Off | 7 | 1.8V / 3.3V | VDDSHV_MCU | Yes | LVCMOS | PU/PD |
| | | | MCU_GPIO0_14 | 7 | IO | pad | | | | | | | | |
| D9 | | MCU_UART1_TXD PADCONFIG: MCU_PADCONFIG15 0x0408403C | MCU_UART1_TXD | 0 | O | | Off / Off / Off | Off / Off / Off | 7 | 1.8V / 3.3V | VDDSHV_MCU | Yes | LVCMOS | PU/PD |
| | | | MCU_GPIO0_15 | 7 | IO | pad | | | | | | | | |
| F18 | | MMC0_CALPAD | MMC0_CALPAD | | A | | | | 1.8V | VDD5_MMC0 | | eMMC PHY | | |
| G18 | | MMC0_CLK | MMC0_CLK | | IO | | On / Low / Off | On / SS / Off | | 1.8V | VDD5_MMC0 | | eMMC PHY | PU/PD |
| J21 | | MMC0_CMD | MMC0_CMD | | IO | | On / High / Up | On / SS / Up | | 1.8V | VDD5_MMC0 | | eMMC PHY | PU/PD |
| G19 | | MMC0_DS | MMC0_DS | | IO | | On / Off / Down | On / Off / Down | | 1.8V | VDD5_MMC0 | | eMMC PHY | PU/PD |

Table 5-1. Pin Attributes (ALV, ANI, ALX Packages) (continued)

| ALV ANI BALL NUMBER [1] | ALX BALL NUMBER [1] | BALL NAME [2] PADCONFIG Register [15] PADCONFIG Address [16] | SIGNAL NAME [3] | MUX MODE [4] | TYPE [5] | DSIS [6] | BALL STATE DURING RESET RX/TX/PULL [7] | BALL STATE AFTER RESET RX/TX/PULL [8] | MUX MODE AFTER RESET [9] | IO OPERATING VOLTAGE [10] | POWER [11] | HYS [12] | BUFFER TYPE [14] | Pull UP/DOWN TYPE [13] | |
|-------------------------|---------------------|--|--------------------------|--------------|----------|----------|--|---------------------------------------|--------------------------|---------------------------|------------|----------|------------------|------------------------|--|
| L20 | J20 | MMC1_CLK PADCONFIG: PADCONFIG163 0x000F428C | MMC1_CLK | 0 | IO | | Off / Off / Off | Off / Off / Off | 7 | 1.8V / 3.3V | VDDSHV5 | Yes | SDIO | PU/PD | |
| | | | UART2_CTSn | 1 | I | 1 | | | | | | | | | |
| | | | TIMER_IO4 | 2 | IO | 0 | | | | | | | | | |
| | | | UART4_RXD | 3 | I | 1 | | | | | | | | | |
| | | | GPIO1_75 | 7 | IO | pad | | | | | | | | | |
| J19 | J21 | MMC1_CMD PADCONFIG: PADCONFIG165 0x000F4294 | MMC1_CMD | 0 | IO | 1 | Off / Off / Off | Off / Off / Off | 7 | 1.8V / 3.3V | VDDSHV5 | Yes | SDIO | PU/PD | |
| | | | UART2_RTSn | 1 | O | | | | | | | | | | |
| | | | TIMER_IO5 | 2 | IO | 0 | | | | | | | | | |
| | | | UART4_TXD | 3 | O | | | | | | | | | | |
| | | | GPIO1_76 | 7 | IO | pad | | | | | | | | | |
| D19 | B17 | MMC1_SDCCD PADCONFIG: PADCONFIG166 0x000F4298 | MMC1_SDCCD | 0 | I | 0 | Off / Off / Off | Off / Off / Off | 7 | 1.8V / 3.3V | VDDSHV0 | Yes | LVC MOS | PU/PD | |
| | | | UART3_CTSn | 1 | I | 1 | | | | | | | | | |
| | | | TIMER_IO6 | 2 | IO | 0 | | | | | | | | | |
| | | | UART5_RXD | 3 | I | 1 | | | | | | | | | |
| | | | GPIO1_77 | 7 | IO | pad | | | | | | | | | |
| C20 | C16 | MMC1_SDWP PADCONFIG: PADCONFIG167 0x000F429C | MMC1_SDWP | 0 | I | 0 | Off / Off / Off | Off / Off / Off | 7 | 1.8V / 3.3V | VDDSHV0 | Yes | LVC MOS | PU/PD | |
| | | | UART3_RTSn | 1 | O | | | | | | | | | | |
| | | | TIMER_IO7 | 2 | IO | 0 | | | | | | | | | |
| | | | UART5_TXD | 3 | O | | | | | | | | | | |
| | | | GPIO1_78 | 7 | IO | pad | | | | | | | | | |
| K20 | | MMC0_DAT0 | MMC0_DAT0 | | IO | | On / Off / Up | On / SS / Up | | 1.8V | VDDS_MMC0 | | eMMC PHY | PU/PD | |
| J20 | | MMC0_DAT1 | MMC0_DAT1 | | IO | | On / Off / Up | On / SS / Up | | 1.8V | VDDS_MMC0 | | eMMC PHY | PU/PD | |
| J18 | | MMC0_DAT2 | MMC0_DAT2 | | IO | | On / Off / Up | On / SS / Up | | 1.8V | VDDS_MMC0 | | eMMC PHY | PU/PD | |
| J17 | | MMC0_DAT3 | MMC0_DAT3 | | IO | | On / Off / Up | On / SS / Up | | 1.8V | VDDS_MMC0 | | eMMC PHY | PU/PD | |
| H17 | | MMC0_DAT4 | MMC0_DAT4 | | IO | | On / Off / Up | On / SS / Up | | 1.8V | VDDS_MMC0 | | eMMC PHY | PU/PD | |
| H19 | | MMC0_DAT5 | MMC0_DAT5 | | IO | | On / Off / Up | On / SS / Up | | 1.8V | VDDS_MMC0 | | eMMC PHY | PU/PD | |
| H18 | | MMC0_DAT6 | MMC0_DAT6 | | IO | | On / Off / Up | On / SS / Up | | 1.8V | VDDS_MMC0 | | eMMC PHY | PU/PD | |
| G17 | | MMC0_DAT7 | MMC0_DAT7 | | IO | | On / Off / Up | On / SS / Up | | 1.8V | VDDS_MMC0 | | eMMC PHY | PU/PD | |
| K21 | J18 | MMC1_DAT0 PADCONFIG: PADCONFIG162 0x000F4288 | MMC1_DAT0 | 0 | IO | 1 | Off / Off / Off | Off / Off / Off | 7 | 1.8V / 3.3V | VDDSHV5 | Yes | SDIO | PU/PD | |
| | | | CP_GEMAC_CPTS0_HW2TSPUSH | 1 | I | 0 | | | | | | | | | |
| | | | TIMER_IO3 | 2 | IO | 0 | | | | | | | | | |
| | | | UART3_TXD | 3 | O | | | | | | | | | | |
| | | | GPIO1_74 | 7 | IO | pad | | | | | | | | | |

Table 5-1. Pin Attributes (ALV, ANI, ALX Packages) (continued)

| ALV ANI BALL NUMBER [1] | ALX BALL NUMBER [1] | BALL NAME [2] PADCONFIG Register [15] PADCONFIG Address [16] | SIGNAL NAME [3] | MUX MODE [4] | TYPE [5] | DSIS [6] | BALL STATE DURING RESET RX/TX/PULL [7] | BALL STATE AFTER RESET RX/TX/PULL [8] | MUX MODE AFTER RESET [9] | IO OPERATING VOLTAGE [10] | POWER [11] | HYS [12] | BUFFER TYPE [14] | Pull UP/DOWN TYPE [13] | |
|-------------------------|---------------------|--|--------------------------|--------------|----------|----------|--|---------------------------------------|--------------------------|---------------------------|------------|----------|------------------|------------------------|--|
| L21 | J19 | MMC1_DAT1 PADCONFIG: PADCONFIG161 0x000F4284 | MMC1_DAT1 | 0 | IO | 1 | Off / Off / Off | Off / Off / Off | 7 | 1.8V / 3.3V | VDDSHV5 | Yes | SDIO | PU/PD | |
| | | | CP_GEMAC_CPTS0_HW1TSPUSH | 1 | I | 0 | | | | | | | | | |
| | | | TIMER_IO2 | 2 | IO | 0 | | | | | | | | | |
| | | | UART3_RXD | 3 | I | 1 | | | | | | | | | |
| | | | GPIO1_73 | 7 | IO | pad | | | | | | | | | |
| K19 | K20 | MMC1_DAT2 PADCONFIG: PADCONFIG160 0x000F4280 | MMC1_DAT2 | 0 | IO | 1 | Off / Off / Off | Off / Off / Off | 7 | 1.8V / 3.3V | VDDSHV5 | Yes | SDIO | PU/PD | |
| | | | CP_GEMAC_CPTS0_TS_SYNC | 1 | O | | | | | | | | | | |
| | | | TIMER_IO1 | 2 | IO | 0 | | | | | | | | | |
| | | | UART2_TXD | 3 | O | | | | | | | | | | |
| | | | GPIO1_72 | 7 | IO | pad | | | | | | | | | |
| K18 | K18 | MMC1_DAT3 PADCONFIG: PADCONFIG159 0x000F427C | MMC1_DAT3 | 0 | IO | 1 | Off / Off / Off | Off / Off / Off | 7 | 1.8V / 3.3V | VDDSHV5 | Yes | SDIO | PU/PD | |
| | | | CP_GEMAC_CPTS0_TS_COMP | 1 | O | | | | | | | | | | |
| | | | TIMER_IO0 | 2 | IO | 0 | | | | | | | | | |
| | | | UART2_RXD | 3 | I | 1 | | | | | | | | | |
| | | | GPIO1_71 | 7 | IO | pad | | | | | | | | | |
| N20 | P20 | OSPI0_CLK PADCONFIG: PADCONFIG0 0x000F4000 | OSPI0_CLK | 0 | O | | Off / Off / Off | Off / Off / Off | 7 | 1.8V / 3.3V | VDDSHV4 | Yes | LVC MOS | PU/PD | |
| | | | GPIO0_0 | 7 | IO | pad | | | | | | | | | |
| N19 | P17 | OSPI0_DQS PADCONFIG: PADCONFIG2 0x000F4008 | OSPI0_DQS | 0 | I | 0 | Off / Off / Off | Off / Off / Off | 7 | 1.8V / 3.3V | VDDSHV4 | Yes | LVC MOS | PU/PD | |
| | | | GPIO0_2 | 7 | IO | pad | | | | | | | | | |
| N21 | M21 | OSPI0_LBCLKO PADCONFIG: PADCONFIG1 0x000F4004 | OSPI0_LBCLKO | 0 | IO | 0 | Off / Off / Off | Off / Off / Off | 7 | 1.8V / 3.3V | VDDSHV4 | Yes | LVC MOS | PU/PD | |
| | | | GPIO0_1 | 7 | IO | pad | | | | | | | | | |
| L19 | L20 | OSPI0_CSn0 PADCONFIG: PADCONFIG11 0x000F402C | OSPI0_CSn0 | 0 | O | | Off / Off / Off | Off / Off / Off | 7 | 1.8V / 3.3V | VDDSHV4 | Yes | LVC MOS | PU/PD | |
| | | | GPIO0_11 | 7 | IO | pad | | | | | | | | | |
| L18 | M20 | OSPI0_CSn1 PADCONFIG: PADCONFIG12 0x000F4030 | OSPI0_CSn1 | 0 | O | | Off / Off / Off | Off / Off / Off | 7 | 1.8V / 3.3V | VDDSHV4 | Yes | LVC MOS | PU/PD | |
| | | | GPIO0_12 | 7 | IO | pad | | | | | | | | | |
| K17 | | OSPI0_CSn2 PADCONFIG: PADCONFIG13 0x000F4034 | OSPI0_CSn2 | 0 | O | | Off / Off / Off | Off / Off / Off | 7 | 1.8V / 3.3V | VDDSHV4 | Yes | LVC MOS | PU/PD | |
| | | | OSPI0_RESET_OUT1 | 2 | O | | | | | | | | | | |
| | | | GPIO0_13 | 7 | IO | pad | | | | | | | | | |

Table 5-1. Pin Attributes (ALV, ANI, ALX Packages) (continued)

| ALV ANI BALL NUMBER [1] | ALX BALL NUMBER [1] | BALL NAME [2] PADCONFIG Register [15] PADCONFIG Address [16] | SIGNAL NAME [3] | MUX MODE [4] | TYPE [5] | DSIS [6] | BALL STATE DURING RESET RX/TX/PULL [7] | BALL STATE AFTER RESET RX/TX/PULL [8] | MUX MODE AFTER RESET [9] | IO OPERATING VOLTAGE [10] | POWER [11] | HYS [12] | BUFFER TYPE [14] | Pull UP/DOWN TYPE [13] |
|-------------------------------------|------------------------------|--|------------------|-----------------|-------------|-------------|---|--|--------------------------------------|---------------------------------|------------|-------------|---------------------|------------------------------|
| L17 | | OSPI0_CSn3 PADCONFIG: PADCONFIG14 0x000F4038 | OSPI0_CSn3 | 0 | O | | Off / Off / Off | Off / Off / Off | 7 | 1.8V / 3.3V | VDDSHV4 | Yes | LVCMOS | PU/PD |
| | | | OSPI0_RESET_OUT0 | 1 | O | | | | | | | | | |
| | | | OSPI0_ECC_FAIL | 2 | I | 1 | | | | | | | | |
| | | | GPIO0_14 | 7 | IO | pad | | | | | | | | |
| M19 | L19 | OSPI0_D0 PADCONFIG: PADCONFIG3 0x000F400C | OSPI0_D0 | 0 | IO | 0 | Off / Off / Off | Off / Off / Off | 7 | 1.8V / 3.3V | VDDSHV4 | Yes | LVCMOS | PU/PD |
| | | | GPIO0_3 | 7 | IO | pad | | | | | | | | |
| M18 | N20 | OSPI0_D1 PADCONFIG: PADCONFIG4 0x000F4010 | OSPI0_D1 | 0 | IO | 0 | Off / Off / Off | Off / Off / Off | 7 | 1.8V / 3.3V | VDDSHV4 | Yes | LVCMOS | PU/PD |
| | | | GPIO0_4 | 7 | IO | pad | | | | | | | | |
| M20 | L21 | OSPI0_D2 PADCONFIG: PADCONFIG5 0x000F4014 | OSPI0_D2 | 0 | IO | 0 | Off / Off / Off | Off / Off / Off | 7 | 1.8V / 3.3V | VDDSHV4 | Yes | LVCMOS | PU/PD |
| | | | GPIO0_5 | 7 | IO | pad | | | | | | | | |
| M21 | N19 | OSPI0_D3 PADCONFIG: PADCONFIG6 0x000F4018 | OSPI0_D3 | 0 | IO | 0 | Off / Off / Off | Off / Off / Off | 7 | 1.8V / 3.3V | VDDSHV4 | Yes | LVCMOS | PU/PD |
| | | | GPIO0_6 | 7 | IO | pad | | | | | | | | |
| P21 | | OSPI0_D4 PADCONFIG: PADCONFIG7 0x000F401C | OSPI0_D4 | 0 | IO | 0 | Off / Off / Off | Off / Off / Off | 7 | 1.8V / 3.3V | VDDSHV4 | Yes | LVCMOS | PU/PD |
| | | | GPIO0_7 | 7 | IO | pad | | | | | | | | |
| P20 | | OSPI0_D5 PADCONFIG: PADCONFIG8 0x000F4020 | OSPI0_D5 | 0 | IO | 0 | Off / Off / Off | Off / Off / Off | 7 | 1.8V / 3.3V | VDDSHV4 | Yes | LVCMOS | PU/PD |
| | | | GPIO0_8 | 7 | IO | pad | | | | | | | | |
| N18 | | OSPI0_D6 PADCONFIG: PADCONFIG9 0x000F4024 | OSPI0_D6 | 0 | IO | 0 | Off / Off / Off | Off / Off / Off | 7 | 1.8V / 3.3V | VDDSHV4 | Yes | LVCMOS | PU/PD |
| | | | GPIO0_9 | 7 | IO | pad | | | | | | | | |
| M17 | | OSPI0_D7 PADCONFIG: PADCONFIG10 0x000F4028 | OSPI0_D7 | 0 | IO | 0 | Off / Off / Off | Off / Off / Off | 7 | 1.8V / 3.3V | VDDSHV4 | Yes | LVCMOS | PU/PD |
| | | | GPIO0_10 | 7 | IO | pad | | | | | | | | |
| E17 | D18 | PORz_OUT PADCONFIG: PADCONFIG171 0x000F42AC | PORz_OUT | 0 | O | | Off / Low / Off | Off / SS / Off | 0 | 1.8V / 3.3V | VDDSHV0 | Yes | LVCMOS | PU/PD |
| P3 | D2 | PRG0_MDIO0_MDC PADCONFIG: PADCONFIG129 0x000F4204 | PRG0_MDIO0_MDC | 0 | O | | Off / Off / Off | Off / Off / Off | 7 | 1.8V / 3.3V | VDDSHV1 | Yes | LVCMOS | PU/PD |
| | | | GPIO1_41 | 7 | IO | pad | | | | | | | | |
| | | | GPMC0_A13 | 9 | OZ | | | | | | | | | |

Table 5-1. Pin Attributes (ALV, ANI, ALX Packages) (continued)

| ALV ANI BALL NUMBER [1] | ALX BALL NUMBER [1] | BALL NAME [2] PADCONFIG Register [15] PADCONFIG Address [16] | SIGNAL NAME [3] | MUX MODE [4] | TYPE [5] | DSIS [6] | BALL STATE DURING RESET RX/TX/PULL [7] | BALL STATE AFTER RESET RX/TX/PULL [8] | MUX MODE AFTER RESET [9] | IO OPERATING VOLTAGE [10] | POWER [11] | HYS [12] | BUFFER TYPE [14] | Pull UP/DOWN TYPE [13] |
|-------------------------|---------------------|--|--------------------|--------------|----------|----------|--|---------------------------------------|--------------------------|---------------------------|------------|----------|------------------|------------------------|
| P2 | E4 | PRG0_MDIO0_MDIO PADCONFIG: PADCONFIG128 0x000F4200 | PRG0_MDIO0_MDIO | 0 | IO | 0 | Off / Off / Off | Off / Off / Off | 7 | 1.8V / 3.3V | VDDSHV1 | Yes | LVCMOS | PU/PD |
| | | | GPIO1_40 | 7 | IO | pad | | | | | | | | |
| | | | GPMC0_A12 | 9 | OZ | | | | | | | | | |
| Y1 | J3 | PRG0_PRU0_GPO0 PADCONFIG: PADCONFIG88 0x000F4160 | PRG0_PRU0_GPO0 | 0 | IO | 0 | Off / Off / Off | Off / Off / Off | 7 | 1.8V / 3.3V | VDDSHV1 | Yes | LVCMOS | PU/PD |
| | | | PRG0_PRU0_GPI0 | 1 | I | 0 | | | | | | | | |
| | | | PRG0_RGMII1_RD0 | 2 | I | 0 | | | | | | | | |
| | | | PRG0_PWM3_A0 | 3 | IO | 0 | | | | | | | | |
| | | | GPIO1_0 | 7 | IO | pad | | | | | | | | |
| | | | UART2_CTSn | 10 | I | 1 | | | | | | | | |
| R4 | J4 | PRG0_PRU0_GPO1 PADCONFIG: PADCONFIG89 0x000F4164 | PRG0_PRU0_GPO1 | 0 | IO | 0 | Off / Off / Off | Off / Off / Off | 7 | 1.8V / 3.3V | VDDSHV1 | Yes | LVCMOS | PU/PD |
| | | | PRG0_PRU0_GPI1 | 1 | I | 0 | | | | | | | | |
| | | | PRG0_RGMII1_RD1 | 2 | I | 0 | | | | | | | | |
| | | | PRG0_PWM3_B0 | 3 | IO | 1 | | | | | | | | |
| | | | GPIO1_1 | 7 | IO | pad | | | | | | | | |
| | | | UART2_TXD | 10 | O | | | | | | | | | |
| U2 | G1 | PRG0_PRU0_GPO2 PADCONFIG: PADCONFIG90 0x000F4168 | PRG0_PRU0_GPO2 | 0 | IO | 0 | Off / Off / Off | Off / Off / Off | 7 | 1.8V / 3.3V | VDDSHV1 | Yes | LVCMOS | PU/PD |
| | | | PRG0_PRU0_GPI2 | 1 | I | 0 | | | | | | | | |
| | | | PRG0_RGMII1_RD2 | 2 | I | 0 | | | | | | | | |
| | | | PRG0_PWM2_A0 | 3 | IO | 0 | | | | | | | | |
| | | | GPIO1_2 | 7 | IO | pad | | | | | | | | |
| | | | GPMC0_A0 | 9 | OZ | | | | | | | | | |
| UART2_RTSn | 10 | O | | | | | | | | | | | | |
| V2 | H1 | PRG0_PRU0_GPO3 PADCONFIG: PADCONFIG91 0x000F416C | PRG0_PRU0_GPO3 | 0 | IO | 0 | Off / Off / Off | Off / Off / Off | 7 | 1.8V / 3.3V | VDDSHV1 | Yes | LVCMOS | PU/PD |
| | | | PRG0_PRU0_GPI3 | 1 | I | 0 | | | | | | | | |
| | | | PRG0_RGMII1_RD3 | 2 | I | 0 | | | | | | | | |
| | | | PRG0_PWM3_A2 | 3 | IO | 0 | | | | | | | | |
| | | | GPIO1_3 | 7 | IO | pad | | | | | | | | |
| | | | UART3_CTSn | 10 | I | 1 | | | | | | | | |
| AA2 | K2 | PRG0_PRU0_GPO4 PADCONFIG: PADCONFIG92 0x000F4170 | PRG0_PRU0_GPO4 | 0 | IO | 0 | Off / Off / Off | Off / Off / Off | 7 | 1.8V / 3.3V | VDDSHV1 | Yes | LVCMOS | PU/PD |
| | | | PRG0_PRU0_GPI4 | 1 | I | 0 | | | | | | | | |
| | | | PRG0_RGMII1_RX_CTL | 2 | I | 0 | | | | | | | | |
| | | | PRG0_PWM2_B0 | 3 | IO | 1 | | | | | | | | |
| | | | GPIO1_4 | 7 | IO | pad | | | | | | | | |
| | | | GPMC0_A1 | 9 | OZ | | | | | | | | | |
| | | | UART3_TXD | 10 | O | | | | | | | | | |

Table 5-1. Pin Attributes (ALV, ANI, ALX Packages) (continued)

| ALV ANI BALL NUMBER [1] | ALX BALL NUMBER [1] | BALL NAME [2] PADCONFIG Register [15] PADCONFIG Address [16] | SIGNAL NAME [3] | MUX MODE [4] | TYPE [5] | DSIS [6] | BALL STATE DURING RESET RX/TX/PULL [7] | BALL STATE AFTER RESET RX/TX/PULL [8] | MUX MODE AFTER RESET [9] | IO OPERATING VOLTAGE [10] | POWER [11] | HYS [12] | BUFFER TYPE [14] | Pull UP/DOWN TYPE [13] |
|-------------------------|---------------------|--|------------------------------|--------------|----------|----------|--|---------------------------------------|--------------------------|---------------------------|------------|----------|------------------|------------------------|
| R3 | F2 | PRG0_PRU0_GPO5 PADCONFIG: PADCONFIG93 0x000F4174 | PRG0_PRU0_GPO5 | 0 | IO | 0 | Off / Off / Off | Off / Off / Off | 7 | 1.8V / 3.3V | VDDSHV1 | Yes | LVCMOS | PU/PD |
| | | | PRG0_PRU0_GPI5 | 1 | I | 0 | | | | | | | | |
| | | | PRG0_PWM3_B2 | 3 | IO | 1 | | | | | | | | |
| | | | GPIO1_5 | 7 | IO | pad | | | | | | | | |
| | | | UART3_RTSn | 10 | O | | | | | | | | | |
| T3 | H2 | PRG0_PRU0_GPO6 PADCONFIG: PADCONFIG94 0x000F4178 | PRG0_PRU0_GPO6 | 0 | IO | 0 | Off / Off / Off | Off / Off / Off | 7 | 1.8V / 3.3V | VDDSHV1 | Yes | LVCMOS | PU/PD |
| | | | PRG0_PRU0_GPI6 | 1 | I | 0 | | | | | | | | |
| | | | PRG0_RGMII1_RXC | 2 | I | 0 | | | | | | | | |
| | | | PRG0_PWM3_A1 | 3 | IO | 0 | | | | | | | | |
| | | | GPIO1_6 | 7 | IO | pad | | | | | | | | |
| | | | UART4_CTSn | 10 | I | 1 | | | | | | | | |
| T1 | E2 | PRG0_PRU0_GPO7 PADCONFIG: PADCONFIG95 0x000F417C | PRG0_PRU0_GPO7 | 0 | IO | 0 | Off / Off / Off | Off / Off / Off | 7 | 1.8V / 3.3V | VDDSHV1 | Yes | LVCMOS | PU/PD |
| | | | PRG0_PRU0_GPI7 | 1 | I | 0 | | | | | | | | |
| | | | PRG0_IEP0_EDC_LATCH_IN1 | 2 | I | 0 | | | | | | | | |
| | | | PRG0_PWM3_B1 | 3 | IO | 1 | | | | | | | | |
| | | | CPTS0_HW2TSPUSH | 4 | I | 0 | | | | | | | | |
| | | | CP_GEMAC_CPTS0_HW2TSPUSH | 5 | I | 0 | | | | | | | | |
| | | | TIMER_IO6 | 6 | IO | 0 | | | | | | | | |
| | | | GPIO1_7 | 7 | IO | pad | | | | | | | | |
| | | | UART4_TXD | 10 | O | | | | | | | | | |
| T2 | H5 | PRG0_PRU0_GPO8 PADCONFIG: PADCONFIG96 0x000F4180 | PRG0_PRU0_GPO8 | 0 | IO | 0 | Off / Off / Off | Off / Off / Off | 7 | 1.8V / 3.3V | VDDSHV1 | Yes | LVCMOS | PU/PD |
| | | | PRG0_PRU0_GPI8 | 1 | I | 0 | | | | | | | | |
| | | | PRG0_PWM2_A1 | 3 | IO | 0 | | | | | | | | |
| | | | GPIO1_8 | 7 | IO | pad | | | | | | | | |
| | | | GPMC0_A2 | 9 | OZ | | | | | | | | | |
| | | | UART4_RTSn | 10 | O | | | | | | | | | |
| W6 | Y3 | PRG0_PRU0_GPO9 PADCONFIG: PADCONFIG97 0x000F4184 | PRG0_PRU0_GPO9 | 0 | IO | 0 | Off / Off / Off | Off / Off / Off | 7 | 1.8V / 3.3V | VDDSHV1 | Yes | LVCMOS | PU/PD |
| | | | PRG0_PRU0_GPI9 | 1 | I | 0 | | | | | | | | |
| | | | PRG0_UART0_CTSn | 2 | I | 1 | | | | | | | | |
| | | | PRG0_PWM3_TZ_IN | 3 | I | 0 | | | | | | | | |
| | | | RGMII1_RX_CTL | 4 | I | 0 | | | | | | | | |
| | | | RMII1_RX_ER | 5 | I | 0 | | | | | | | | |
| | | | PRG0_IEP0_EDIO_DATA_IN_OUT28 | 6 | IO | 0 | | | | | | | | |
| | | | GPIO1_9 | 7 | IO | pad | | | | | | | | |
| | | | UART2_RXD | 10 | I | 1 | | | | | | | | |

Table 5-1. Pin Attributes (ALV, ANI, ALX Packages) (continued)

| ALV ANI BALL NUMBER [1] | ALX BALL NUMBER [1] | BALL NAME [2] PADCONFIG Register [15] PADCONFIG Address [16] | SIGNAL NAME [3] | MUX MODE [4] | TYPE [5] | DSIS [6] | BALL STATE DURING RESET RX/TX/PULL [7] | BALL STATE AFTER RESET RX/TX/PULL [8] | MUX MODE AFTER RESET [9] | IO OPERATING VOLTAGE [10] | POWER [11] | HYS [12] | BUFFER TYPE [14] | Pull UP/DOWN TYPE [13] |
|-------------------------|---------------------|--|------------------------------|--------------|----------|----------|--|---------------------------------------|--------------------------|---------------------------|------------|----------|------------------|------------------------|
| AA5 | U1 | PRG0_PRU0_GPO10 PADCONFIG: PADCONFIG98 0x000F4188 | PRG0_PRU0_GPO10 | 0 | IO | 0 | Off / Off / Off | Off / Off / Off | 7 | 1.8V / 3.3V | VDDSHV1 | Yes | LVCMOS | PU/PD |
| | | | PRG0_PRU0_GPI10 | 1 | I | 0 | | | | | | | | |
| | | | PRG0_UART0_RTSn | 2 | O | | | | | | | | | |
| | | | PRG0_PWM2_B1 | 3 | IO | 1 | | | | | | | | |
| | | | RGMI1_RXC | 4 | I | 0 | | | | | | | | |
| | | | RMII_REF_CLK | 5 | I | 0 | | | | | | | | |
| | | | PRG0_IEP0_EDIO_DATA_IN_OUT29 | 6 | IO | 0 | | | | | | | | |
| | | | GPIO1_10 | 7 | IO | pad | | | | | | | | |
| UART3_RXD | 10 | I | 1 | | | | | | | | | | | |
| Y3 | L1 | PRG0_PRU0_GPO11 PADCONFIG: PADCONFIG99 0x000F418C | PRG0_PRU0_GPO11 | 0 | IO | 0 | Off / Off / Off | Off / Off / Off | 7 | 1.8V / 3.3V | VDDSHV1 | Yes | LVCMOS | PU/PD |
| | | | PRG0_PRU0_GPI11 | 1 | I | 0 | | | | | | | | |
| | | | PRG0_RGMII1_TD0 | 2 | O | | | | | | | | | |
| | | | PRG0_PWM3_TZ_OUT | 3 | O | | | | | | | | | |
| | | | GPIO1_11 | 7 | IO | pad | | | | | | | | |
| | | | UART4_RXD | 10 | I | 1 | | | | | | | | |
| AA3 | K1 | PRG0_PRU0_GPO12 PADCONFIG: PADCONFIG100 0x000F4190 | PRG0_PRU0_GPO12 | 0 | IO | 0 | Off / Off / Off | Off / Off / Off | 7 | 1.8V / 3.3V | VDDSHV1 | Yes | LVCMOS | PU/PD |
| | | | PRG0_PRU0_GPI12 | 1 | I | 0 | | | | | | | | |
| | | | PRG0_RGMII1_TD1 | 2 | O | | | | | | | | | |
| | | | PRG0_PWM0_A0 | 3 | IO | 0 | | | | | | | | |
| | | | GPIO1_12 | 7 | IO | pad | | | | | | | | |
| | | | GPMC0_A14 | 9 | OZ | | | | | | | | | |
| R6 | N1 | PRG0_PRU0_GPO13 PADCONFIG: PADCONFIG101 0x000F4194 | PRG0_PRU0_GPO13 | 0 | IO | 0 | Off / Off / Off | Off / Off / Off | 7 | 1.8V / 3.3V | VDDSHV1 | Yes | LVCMOS | PU/PD |
| | | | PRG0_PRU0_GPI13 | 1 | I | 0 | | | | | | | | |
| | | | PRG0_RGMII1_TD2 | 2 | O | | | | | | | | | |
| | | | PRG0_PWM0_B0 | 3 | IO | 1 | | | | | | | | |
| | | | SPI3_D0 | 6 | IO | 0 | | | | | | | | |
| | | | GPIO1_13 | 7 | IO | pad | | | | | | | | |
| | | | GPMC0_A15 | 9 | OZ | | | | | | | | | |
| V4 | N2 | PRG0_PRU0_GPO14 PADCONFIG: PADCONFIG102 0x000F4198 | PRG0_PRU0_GPO14 | 0 | IO | 0 | Off / Off / Off | Off / Off / Off | 7 | 1.8V / 3.3V | VDDSHV1 | Yes | LVCMOS | PU/PD |
| | | | PRG0_PRU0_GPI14 | 1 | I | 0 | | | | | | | | |
| | | | PRG0_RGMII1_TD3 | 2 | O | | | | | | | | | |
| | | | PRG0_PWM0_A1 | 3 | IO | 0 | | | | | | | | |
| | | | SPI3_D1 | 6 | IO | 0 | | | | | | | | |
| | | | GPIO1_14 | 7 | IO | pad | | | | | | | | |
| | | | GPMC0_A3 | 9 | OZ | | | | | | | | | |

Table 5-1. Pin Attributes (ALV, ANI, ALX Packages) (continued)

| ALV ANI BALL NUMBER [1] | ALX BALL NUMBER [1] | BALL NAME [2] PADCONFIG Register [15] PADCONFIG Address [16] | SIGNAL NAME [3] | MUX MODE [4] | TYPE [5] | DSIS [6] | BALL STATE DURING RESET RX/TX/PULL [7] | BALL STATE AFTER RESET RX/TX/PULL [8] | MUX MODE AFTER RESET [9] | IO OPERATING VOLTAGE [10] | POWER [11] | HYS [12] | BUFFER TYPE [14] | Pull UP/DOWN TYPE [13] |
|-------------------------|---------------------|--|--------------------------|--------------|----------|----------|--|---------------------------------------|--------------------------|---------------------------|------------|----------|------------------|------------------------|
| T5 | N4 | PRG0_PRU0_GPO15 PADCONFIG: PADCONFIG103 0x000F419C | PRG0_PRU0_GPO15 | 0 | IO | 0 | Off / Off / Off | Off / Off / Off | 7 | 1.8V / 3.3V | VDDSHV1 | Yes | LVCMOS | PU/PD |
| | | | PRG0_PRU0_GPI15 | 1 | I | 0 | | | | | | | | |
| | | | PRG0_RGMII1_TX_CTL | 2 | O | | | | | | | | | |
| | | | PRG0_PWM0_B1 | 3 | IO | 1 | | | | | | | | |
| | | | SPI3_CS1 | 6 | IO | 1 | | | | | | | | |
| | | | GPIO1_15 | 7 | IO | pad | | | | | | | | |
| U4 | N3 | PRG0_PRU0_GPO16 PADCONFIG: PADCONFIG104 0x000F41A0 | PRG0_PRU0_GPO16 | 0 | IO | 0 | Off / Off / Off | Off / Off / Off | 7 | 1.8V / 3.3V | VDDSHV1 | Yes | LVCMOS | PU/PD |
| | | | PRG0_PRU0_GPI16 | 1 | I | 0 | | | | | | | | |
| | | | PRG0_RGMII1_TXC | 2 | IO | 0 | | | | | | | | |
| | | | PRG0_PWM0_A2 | 3 | IO | 0 | | | | | | | | |
| | | | SPI3_CLK | 6 | IO | 0 | | | | | | | | |
| | | | GPIO1_16 | 7 | IO | pad | | | | | | | | |
| U1 | E1 | PRG0_PRU0_GPO17 PADCONFIG: PADCONFIG105 0x000F41A4 | PRG0_PRU0_GPO17 | 0 | IO | 0 | Off / Off / Off | Off / Off / Off | 7 | 1.8V / 3.3V | VDDSHV1 | Yes | LVCMOS | PU/PD |
| | | | PRG0_PRU0_GPI17 | 1 | I | 0 | | | | | | | | |
| | | | PRG0_IEP0_EDC_SYNC_OUT1 | 2 | O | | | | | | | | | |
| | | | PRG0_PWM0_B2 | 3 | IO | 1 | | | | | | | | |
| | | | CPTS0_TS_SYNC | 4 | O | | | | | | | | | |
| | | | CP_GEMAC_CPTS0_TS_SYNC | 5 | O | | | | | | | | | |
| | | | SPI3_CS0 | 6 | IO | 1 | | | | | | | | |
| | | | GPIO1_17 | 7 | IO | pad | | | | | | | | |
| | | | TIMER_IO11 | 8 | IO | 0 | | | | | | | | |
| GPMC0_A17 | 9 | OZ | | | | | | | | | | | | |
| V1 | K4 | PRG0_PRU0_GPO18 PADCONFIG: PADCONFIG106 0x000F41A8 | PRG0_PRU0_GPO18 | 0 | IO | 0 | Off / Off / Off | Off / Off / Off | 7 | 1.8V / 3.3V | VDDSHV1 | Yes | LVCMOS | PU/PD |
| | | | PRG0_PRU0_GPI18 | 1 | I | 0 | | | | | | | | |
| | | | PRG0_IEP0_EDC_LATCH_IN0 | 2 | I | 0 | | | | | | | | |
| | | | PRG0_PWM0_TZ_IN | 3 | I | 0 | | | | | | | | |
| | | | CPTS0_HW1TSPUSH | 4 | I | 0 | | | | | | | | |
| | | | CP_GEMAC_CPTS0_HW1TSPUSH | 5 | I | 0 | | | | | | | | |
| | | | EHRPWM8_A | 6 | IO | 0 | | | | | | | | |
| | | | GPIO1_18 | 7 | IO | pad | | | | | | | | |
| | | | UART4_CTSn | 8 | I | 1 | | | | | | | | |
| | | | GPMC0_A5 | 9 | OZ | | | | | | | | | |
| | | | UART2_RXD | 10 | I | 1 | | | | | | | | |

Table 5-1. Pin Attributes (ALV, ANI, ALX Packages) (continued)

| ALV ANI BALL NUMBER [1] | ALX BALL NUMBER [1] | BALL NAME [2] PADCONFIG Register [15] PADCONFIG Address [16] | SIGNAL NAME [3] | MUX MODE [4] | TYPE [5] | DSIS [6] | BALL STATE DURING RESET RX/TX/PULL [7] | BALL STATE AFTER RESET RX/TX/PULL [8] | MUX MODE AFTER RESET [9] | IO OPERATING VOLTAGE [10] | POWER [11] | HYS [12] | BUFFER TYPE [14] | Pull UP/DOWN TYPE [13] |
|-------------------------------------|------------------------------|--|-------------------------|-----------------|-------------|-------------|---|--|--------------------------------------|---------------------------------|------------|-------------|---------------------|------------------------------|
| W1 | G2 | PRG0_PRU0_GPO19 PADCONFIG: PADCONFIG107 0x000F41AC | PRG0_PRU0_GPO19 | 0 | IO | 0 | Off / Off / Off | Off / Off / Off | 7 | 1.8V / 3.3V | VDDSHV1 | Yes | LVCMOS | PU/PD |
| | | | PRG0_PRU0_GPI19 | 1 | I | 0 | | | | | | | | |
| | | | PRG0_IEP0_EDC_SYNC_OUT0 | 2 | O | | | | | | | | | |
| | | | PRG0_PWM0_TZ_OUT | 3 | O | | | | | | | | | |
| | | | CPTS0_TS_COMP | 4 | O | | | | | | | | | |
| | | | CP_GEMAC_CPTS0_TS_COMP | 5 | O | | | | | | | | | |
| | | | EHRPWM8_B | 6 | IO | 0 | | | | | | | | |
| | | | GPIO1_19 | 7 | IO | pad | | | | | | | | |
| | | | UART4_RTSn | 8 | O | | | | | | | | | |
| | | | GPMC0_A6 | 9 | OZ | | | | | | | | | |
| UART3_RXD | 10 | I | 1 | | | | | | | | | | | |
| Y2 | L5 | PRG0_PRU1_GPO0 PADCONFIG: PADCONFIG108 0x000F41B0 | PRG0_PRU1_GPO0 | 0 | IO | 0 | Off / Off / Off | Off / Off / Off | 7 | 1.8V / 3.3V | VDDSHV1 | Yes | LVCMOS | PU/PD |
| | | | PRG0_PRU1_GPI0 | 1 | I | 0 | | | | | | | | |
| | | | PRG0_RGMII2_RD0 | 2 | I | 0 | | | | | | | | |
| | | | GPIO1_20 | 7 | IO | pad | | | | | | | | |
| | | | EQEP0_A | 8 | I | 0 | | | | | | | | |
| | | | UART5_CTSn | 10 | I | 1 | | | | | | | | |
| W2 | J2 | PRG0_PRU1_GPO1 PADCONFIG: PADCONFIG109 0x000F41B4 | PRG0_PRU1_GPO1 | 0 | IO | 0 | Off / Off / Off | Off / Off / Off | 7 | 1.8V / 3.3V | VDDSHV1 | Yes | LVCMOS | PU/PD |
| | | | PRG0_PRU1_GPI1 | 1 | I | 0 | | | | | | | | |
| | | | PRG0_RGMII2_RD1 | 2 | I | 0 | | | | | | | | |
| | | | GPIO1_21 | 7 | IO | pad | | | | | | | | |
| | | | EQEP0_B | 8 | I | 0 | | | | | | | | |
| | | | UART5_TXD | 10 | O | | | | | | | | | |
| V3 | M2 | PRG0_PRU1_GPO2 PADCONFIG: PADCONFIG110 0x000F41B8 | PRG0_PRU1_GPO2 | 0 | IO | 0 | Off / Off / Off | Off / Off / Off | 7 | 1.8V / 3.3V | VDDSHV1 | Yes | LVCMOS | PU/PD |
| | | | PRG0_PRU1_GPI2 | 1 | I | 0 | | | | | | | | |
| | | | PRG0_RGMII2_RD2 | 2 | I | 0 | | | | | | | | |
| | | | PRG0_PWM2_A2 | 3 | IO | 0 | | | | | | | | |
| | | | GPIO1_22 | 7 | IO | pad | | | | | | | | |
| | | | EQEP0_S | 8 | IO | 0 | | | | | | | | |
| | | | UART5_RTSn | 10 | O | | | | | | | | | |

Table 5-1. Pin Attributes (ALV, ANI, ALX Packages) (continued)

| ALV ANI BALL NUMBER [1] | ALX BALL NUMBER [1] | BALL NAME [2] PADCONFIG Register [15] PADCONFIG Address [16] | SIGNAL NAME [3] | MUX MODE [4] | TYPE [5] | DSIS [6] | BALL STATE DURING RESET RX/TX/PULL [7] | BALL STATE AFTER RESET RX/TX/PULL [8] | MUX MODE AFTER RESET [9] | IO OPERATING VOLTAGE [10] | POWER [11] | HYS [12] | BUFFER TYPE [14] | Pull UP/DOWN TYPE [13] |
|-------------------------|---------------------|--|-------------------------|--------------|----------|----------|--|---------------------------------------|--------------------------|---------------------------|------------|----------|------------------|------------------------|
| T4 | L2 | PRG0_PRU1_GPO3 PADCONFIG: PADCONFIG111 0x000F41BC | PRG0_PRU1_GPO3 | 0 | IO | 0 | Off / Off / Off | Off / Off / Off | 7 | 1.8V / 3.3V | VDDSHV1 | Yes | LVCMOS | PU/PD |
| | | | PRG0_PRU1_GPI3 | 1 | I | 0 | | | | | | | | |
| | | | PRG0_RGMII2_RD3 | 2 | I | 0 | | | | | | | | |
| | | | GPIO1_23 | 7 | IO | pad | | | | | | | | |
| | | | EQEP1_A | 8 | I | 0 | | | | | | | | |
| | | | GPMC0_A18 | 9 | OZ | | | | | | | | | |
| | | | UART6_CTSn | 10 | I | 1 | | | | | | | | |
| W3 | L3 | PRG0_PRU1_GPO4 PADCONFIG: PADCONFIG112 0x000F41C0 | PRG0_PRU1_GPO4 | 0 | IO | 0 | Off / Off / Off | Off / Off / Off | 7 | 1.8V / 3.3V | VDDSHV1 | Yes | LVCMOS | PU/PD |
| | | | PRG0_PRU1_GPI4 | 1 | I | 0 | | | | | | | | |
| | | | PRG0_RGMII2_RX_CTL | 2 | I | 0 | | | | | | | | |
| | | | PRG0_PWM2_B2 | 3 | IO | 1 | | | | | | | | |
| | | | GPIO1_24 | 7 | IO | pad | | | | | | | | |
| | | | EQEP1_B | 8 | I | 0 | | | | | | | | |
| | | | UART6_TXD | 10 | O | | | | | | | | | |
| P4 | E3 | PRG0_PRU1_GPO5 PADCONFIG: PADCONFIG113 0x000F41C4 | PRG0_PRU1_GPO5 | 0 | IO | 0 | Off / Off / Off | Off / Off / Off | 7 | 1.8V / 3.3V | VDDSHV1 | Yes | LVCMOS | PU/PD |
| | | | PRG0_PRU1_GPI5 | 1 | I | 0 | | | | | | | | |
| | | | GPIO1_25 | 7 | IO | pad | | | | | | | | |
| | | | EQEP1_S | 8 | IO | 0 | | | | | | | | |
| | | | UART6_RTSn | 10 | O | | | | | | | | | |
| R5 | F5 | PRG0_PRU1_GPO6 PADCONFIG: PADCONFIG114 0x000F41C8 | PRG0_PRU1_GPO6 | 0 | IO | 0 | Off / Off / Off | Off / Off / Off | 7 | 1.8V / 3.3V | VDDSHV1 | Yes | LVCMOS | PU/PD |
| | | | PRG0_PRU1_GPI6 | 1 | I | 0 | | | | | | | | |
| | | | PRG0_RGMII2_RXC | 2 | I | 0 | | | | | | | | |
| | | | GPIO1_26 | 7 | IO | pad | | | | | | | | |
| | | | EQEP2_A | 8 | I | 0 | | | | | | | | |
| | | | GPMC0_A19 | 9 | OZ | | | | | | | | | |
| | | | UART4_CTSn | 10 | I | 1 | | | | | | | | |
| W5 | T5 | PRG0_PRU1_GPO7 PADCONFIG: PADCONFIG115 0x000F41CC | PRG0_PRU1_GPO7 | 0 | IO | 0 | Off / Off / Off | Off / Off / Off | 7 | 1.8V / 3.3V | VDDSHV1 | Yes | LVCMOS | PU/PD |
| | | | PRG0_PRU1_GPI7 | 1 | I | 0 | | | | | | | | |
| | | | PRG0_IEP1_EDC_LATCH_IN1 | 2 | I | 0 | | | | | | | | |
| | | | RGMII1_RD0 | 4 | I | 0 | | | | | | | | |
| | | | RMII1_RXD0 | 5 | I | 0 | | | | | | | | |
| | | | GPIO1_27 | 7 | IO | pad | | | | | | | | |
| | | | EQEP2_B | 8 | I | 0 | | | | | | | | |
| | | | UART4_TXD | 10 | O | | | | | | | | | |

Table 5-1. Pin Attributes (ALV, ANI, ALX Packages) (continued)

| ALV ANI BALL NUMBER [1] | ALX BALL NUMBER [1] | BALL NAME [2] PADCONFIG Register [15] PADCONFIG Address [16] | SIGNAL NAME [3] | MUX MODE [4] | TYPE [5] | DSIS [6] | BALL STATE DURING RESET RX/TX/PULL [7] | BALL STATE AFTER RESET RX/TX/PULL [8] | MUX MODE AFTER RESET [9] | IO OPERATING VOLTAGE [10] | POWER [11] | HYS [12] | BUFFER TYPE [14] | Pull UP/DOWN TYPE [13] |
|-------------------------|---------------------|--|------------------------------|--------------|----------|----------|--|---------------------------------------|--------------------------|---------------------------|------------|----------|------------------|------------------------|
| R1 | F4 | PRG0_PRU1_GPO8 PADCONFIG: PADCONFIG116 0x000F41D0 | PRG0_PRU1_GPO8 | 0 | IO | 0 | Off / Off / Off | Off / Off / Off | 7 | 1.8V / 3.3V | VDDSHV1 | Yes | LVCMOS | PU/PD |
| | | | PRG0_PRU1_GPI8 | 1 | I | 0 | | | | | | | | |
| | | | PRG0_PWM2_TZ_OUT | 3 | O | | | | | | | | | |
| | | | GPIO1_28 | 7 | IO | pad | | | | | | | | |
| | | | EQEP2_S | 8 | IO | 0 | | | | | | | | |
| UART4_RTSn | 10 | O | | | | | | | | | | | | |
| Y5 | R2 | PRG0_PRU1_GPO9 PADCONFIG: PADCONFIG117 0x000F41D4 | PRG0_PRU1_GPO9 | 0 | IO | 0 | Off / Off / Off | Off / Off / Off | 7 | 1.8V / 3.3V | VDDSHV1 | Yes | LVCMOS | PU/PD |
| | | | PRG0_PRU1_GPI9 | 1 | I | 0 | | | | | | | | |
| | | | PRG0_UART0_RXD | 2 | I | 1 | | | | | | | | |
| | | | RGMI1_RD1 | 4 | I | 0 | | | | | | | | |
| | | | RMII1_RXD1 | 5 | I | 0 | | | | | | | | |
| | | | PRG0_IEP0_EDIO_DATA_IN_OUT30 | 6 | IO | 0 | | | | | | | | |
| | | | GPIO1_29 | 7 | IO | pad | | | | | | | | |
| | | | EQEP0_J | 8 | IO | 0 | | | | | | | | |
| UART5_RXD | 10 | I | 1 | | | | | | | | | | | |
| V6 | U2 | PRG0_PRU1_GPO10 PADCONFIG: PADCONFIG118 0x000F41D8 | PRG0_PRU1_GPO10 | 0 | IO | 0 | Off / Off / Off | Off / Off / Off | 7 | 1.8V / 3.3V | VDDSHV1 | Yes | LVCMOS | PU/PD |
| | | | PRG0_PRU1_GPI10 | 1 | I | 0 | | | | | | | | |
| | | | PRG0_UART0_TXD | 2 | O | | | | | | | | | |
| | | | PRG0_PWM2_TZ_IN | 3 | I | 0 | | | | | | | | |
| | | | RGMI1_RD2 | 4 | I | 0 | | | | | | | | |
| | | | RMII1_TXD0 | 5 | O | | | | | | | | | |
| | | | PRG0_IEP0_EDIO_DATA_IN_OUT31 | 6 | IO | 0 | | | | | | | | |
| | | | GPIO1_30 | 7 | IO | pad | | | | | | | | |
| | | | EQEP1_I | 8 | IO | 0 | | | | | | | | |
| UART6_RXD | 10 | I | 1 | | | | | | | | | | | |
| W4 | P1 | PRG0_PRU1_GPO11 PADCONFIG: PADCONFIG119 0x000F41DC | PRG0_PRU1_GPO11 | 0 | IO | 0 | Off / Off / Off | Off / Off / Off | 7 | 1.8V / 3.3V | VDDSHV1 | Yes | LVCMOS | PU/PD |
| | | | PRG0_PRU1_GPI11 | 1 | I | 0 | | | | | | | | |
| | | | PRG0_RGMII2_TD0 | 2 | O | | | | | | | | | |
| | | | GPIO1_31 | 7 | IO | pad | | | | | | | | |
| | | | EQEP2_I | 8 | IO | 0 | | | | | | | | |
| UART4_RXD | 10 | I | 1 | | | | | | | | | | | |

Table 5-1. Pin Attributes (ALV, ANI, ALX Packages) (continued)

| ALV ANI BALL NUMBER [1] | ALX BALL NUMBER [1] | BALL NAME [2] PADCONFIG Register [15] PADCONFIG Address [16] | SIGNAL NAME [3] | MUX MODE [4] | TYPE [5] | DSIS [6] | BALL STATE DURING RESET RX/TX/PULL [7] | BALL STATE AFTER RESET RX/TX/PULL [8] | MUX MODE AFTER RESET [9] | IO OPERATING VOLTAGE [10] | POWER [11] | HYS [12] | BUFFER TYPE [14] | Pull UP/DOWN TYPE [13] |
|-------------------------|---------------------|--|--------------------|--------------|----------|----------|--|---------------------------------------|--------------------------|---------------------------|------------|----------|------------------|------------------------|
| Y4 | P2 | PRG0_PRU1_GPO12 PADCONFIG: PADCONFIG120 0x000F41E0 | PRG0_PRU1_GPO12 | 0 | IO | 0 | Off / Off / Off | Off / Off / Off | 7 | 1.8V / 3.3V | VDDSHV1 | Yes | LVCMOS | PU/PD |
| | | | PRG0_PRU1_GPI12 | 1 | I | 0 | | | | | | | | |
| | | | PRG0_RGMII2_TD1 | 2 | O | | | | | | | | | |
| | | | PRG0_PWM1_A0 | 3 | IO | 0 | | | | | | | | |
| | | | GPIO1_32 | 7 | IO | pad | | | | | | | | |
| | | | EQEP2_B | 8 | I | 0 | | | | | | | | |
| | | | GPMC0_A7 | 9 | OZ | | | | | | | | | |
| UART4_TXD | 10 | O | | | | | | | | | | | | |
| T6 | T4 | PRG0_PRU1_GPO13 PADCONFIG: PADCONFIG121 0x000F41E4 | PRG0_PRU1_GPO13 | 0 | IO | 0 | Off / Off / Off | Off / Off / Off | 7 | 1.8V / 3.3V | VDDSHV1 | Yes | LVCMOS | PU/PD |
| | | | PRG0_PRU1_GPI13 | 1 | I | 0 | | | | | | | | |
| | | | PRG0_RGMII2_TD2 | 2 | O | | | | | | | | | |
| | | | PRG0_PWM1_B0 | 3 | IO | 1 | | | | | | | | |
| | | | GPIO1_33 | 7 | IO | pad | | | | | | | | |
| | | | EQEP0_J | 8 | IO | 0 | | | | | | | | |
| | | | GPMC0_A8 | 9 | OZ | | | | | | | | | |
| UART5_RXD | 10 | I | 1 | | | | | | | | | | | |
| U6 | R5 | PRG0_PRU1_GPO14 PADCONFIG: PADCONFIG122 0x000F41E8 | PRG0_PRU1_GPO14 | 0 | IO | 0 | Off / Off / Off | Off / Off / Off | 7 | 1.8V / 3.3V | VDDSHV1 | Yes | LVCMOS | PU/PD |
| | | | PRG0_PRU1_GPI14 | 1 | I | 0 | | | | | | | | |
| | | | PRG0_RGMII2_TD3 | 2 | O | | | | | | | | | |
| | | | PRG0_PWM1_A1 | 3 | IO | 0 | | | | | | | | |
| | | | GPIO1_34 | 7 | IO | pad | | | | | | | | |
| | | | EQEP1_I | 8 | IO | 0 | | | | | | | | |
| | | | GPMC0_A9 | 9 | OZ | | | | | | | | | |
| UART6_RXD | 10 | I | 1 | | | | | | | | | | | |
| U5 | M4 | PRG0_PRU1_GPO15 PADCONFIG: PADCONFIG123 0x000F41EC | PRG0_PRU1_GPO15 | 0 | IO | 0 | Off / Off / Off | Off / Off / Off | 7 | 1.8V / 3.3V | VDDSHV1 | Yes | LVCMOS | PU/PD |
| | | | PRG0_PRU1_GPI15 | 1 | I | 0 | | | | | | | | |
| | | | PRG0_RGMII2_TX_CTL | 2 | O | | | | | | | | | |
| | | | PRG0_PWM1_B1 | 3 | IO | 1 | | | | | | | | |
| | | | GPIO1_35 | 7 | IO | pad | | | | | | | | |
| | | | GPMC0_A10 | 9 | OZ | | | | | | | | | |
| PRG0_ECAP0_IN_APWM_OUT | 10 | IO | 0 | | | | | | | | | | | |

Table 5-1. Pin Attributes (ALV, ANI, ALX Packages) (continued)

| ALV ANI BALL NUMBER [1] | ALX BALL NUMBER [1] | BALL NAME [2] PADCONFIG Register [15] PADCONFIG Address [16] | SIGNAL NAME [3] | MUX MODE [4] | TYPE [5] | DSIS [6] | BALL STATE DURING RESET RX/TX/PULL [7] | BALL STATE AFTER RESET RX/TX/PULL [8] | MUX MODE AFTER RESET [9] | IO OPERATING VOLTAGE [10] | POWER [11] | HYS [12] | BUFFER TYPE [14] | Pull UP/DOWN TYPE [13] |
|-------------------------|---------------------|--|-------------------------|--------------|----------|----------|--|---------------------------------------|--------------------------|---------------------------|------------|----------|------------------|------------------------|
| AA4 | T3 | PRG0_PRU1_GPO16 PADCONFIG: PADCONFIG124 0x000F41F0 | PRG0_PRU1_GPO16 | 0 | IO | 0 | Off / Off / Off | Off / Off / Off | 7 | 1.8V / 3.3V | VDDSHV1 | Yes | LVCMOS | PU/PD |
| | | | PRG0_PRU1_GPI16 | 1 | I | 0 | | | | | | | | |
| | | | PRG0_RGMII2_TXC | 2 | IO | 0 | | | | | | | | |
| | | | PRG0_PWM1_A2 | 3 | IO | 0 | | | | | | | | |
| | | | GPIO1_36 | 7 | IO | pad | | | | | | | | |
| | | | GPMC0_A11 | 9 | OZ | | | | | | | | | |
| PRG0_ECAP0_SYNC_OUT | 10 | O | | | | | | | | | | | | |
| V5 | T1 | PRG0_PRU1_GPO17 PADCONFIG: PADCONFIG125 0x000F41F4 | PRG0_PRU1_GPO17 | 0 | IO | 0 | Off / Off / Off | Off / Off / Off | 7 | 1.8V / 3.3V | VDDSHV1 | Yes | LVCMOS | PU/PD |
| | | | PRG0_PRU1_GPI17 | 1 | I | 0 | | | | | | | | |
| | | | PRG0_IEP1_EDC_SYNC_OUT1 | 2 | O | | | | | | | | | |
| | | | PRG0_PWM1_B2 | 3 | IO | 1 | | | | | | | | |
| | | | RGMII1_RD3 | 4 | I | 0 | | | | | | | | |
| | | | RMII1_TXD1 | 5 | O | | | | | | | | | |
| | | | GPIO1_37 | 7 | IO | pad | | | | | | | | |
| | | | PRG0_ECAP0_SYNC_OUT | 8 | O | | | | | | | | | |
| PRG0_ECAP0_SYNC_IN | 10 | I | 0 | | | | | | | | | | | |
| P5 | D1 | PRG0_PRU1_GPO18 PADCONFIG: PADCONFIG126 0x000F41F8 | PRG0_PRU1_GPO18 | 0 | IO | 0 | Off / Off / Off | Off / Off / Off | 7 | 1.8V / 3.3V | VDDSHV1 | Yes | LVCMOS | PU/PD |
| | | | PRG0_PRU1_GPI18 | 1 | I | 0 | | | | | | | | |
| | | | PRG0_IEP1_EDC_LATCH_IN0 | 2 | I | 0 | | | | | | | | |
| | | | PRG0_PWM1_TZ_IN | 3 | I | 0 | | | | | | | | |
| | | | MDIO0_MDIO | 4 | IO | 0 | | | | | | | | |
| | | | RMII1_TX_EN | 5 | O | | | | | | | | | |
| | | | EHRPWM7_A | 6 | IO | 0 | | | | | | | | |
| | | | GPIO1_38 | 7 | IO | pad | | | | | | | | |
| PRG0_ECAP0_SYNC_IN | 8 | I | 0 | | | | | | | | | | | |
| R2 | F3 | PRG0_PRU1_GPO19 PADCONFIG: PADCONFIG127 0x000F41FC | PRG0_PRU1_GPO19 | 0 | IO | 0 | Off / Off / Off | Off / Off / Off | 7 | 1.8V / 3.3V | VDDSHV1 | Yes | LVCMOS | PU/PD |
| | | | PRG0_PRU1_GPI19 | 1 | I | 0 | | | | | | | | |
| | | | PRG0_IEP1_EDC_SYNC_OUT0 | 2 | O | | | | | | | | | |
| | | | PRG0_PWM1_TZ_OUT | 3 | O | | | | | | | | | |
| | | | MDIO0_MDC | 4 | O | | | | | | | | | |
| | | | RMII1_CRIS_DV | 5 | I | 0 | | | | | | | | |
| | | | EHRPWM7_B | 6 | IO | 0 | | | | | | | | |
| | | | GPIO1_39 | 7 | IO | pad | | | | | | | | |
| PRG0_ECAP0_IN_APWM_OUT | 8 | IO | 0 | | | | | | | | | | | |

Table 5-1. Pin Attributes (ALV, ANI, ALX Packages) (continued)

| ALV ANI BALL NUMBER [1] | ALX BALL NUMBER [1] | BALL NAME [2] PADCONFIG Register [15] PADCONFIG Address [16] | SIGNAL NAME [3] | MUX MODE [4] | TYPE [5] | DSIS [6] | BALL STATE DURING RESET RX/TX/PULL [7] | BALL STATE AFTER RESET RX/TX/PULL [8] | MUX MODE AFTER RESET [9] | IO OPERATING VOLTAGE [10] | POWER [11] | HYS [12] | BUFFER TYPE [14] | Pull UP/DOWN TYPE [13] |
|-------------------------|---------------------|--|--------------------|--------------|----------|----------|--|---------------------------------------|--------------------------|---------------------------|------------|----------|------------------|------------------------|
| Y6 | W1 | PRG1_MDIO0_MDC PADCONFIG: PADCONFIG87 0x000F415C | PRG1_MDIO0_MDC | 0 | O | | Off / Off / Off | Off / Off / Off | 7 | 1.8V / 3.3V | VDDSHV2 | Yes | LVC MOS | PU/PD |
| | | | MDIO0_MDC | 4 | O | | | | | | | | | |
| | | | GPIO0_86 | 7 | IO | pad | | | | | | | | |
| AA6 | V2 | PRG1_MDIO0_MDIO PADCONFIG: PADCONFIG86 0x000F4158 | PRG1_MDIO0_MDIO | 0 | IO | 0 | Off / Off / Off | Off / Off / Off | 7 | 1.8V / 3.3V | VDDSHV2 | Yes | LVC MOS | PU/PD |
| | | | MDIO0_MDIO | 4 | IO | 0 | | | | | | | | |
| | | | GPIO0_85 | 7 | IO | pad | | | | | | | | |
| Y7 | V4 | PRG1_PRU0_GPO0 PADCONFIG: PADCONFIG46 0x000F40B8 | PRG1_PRU0_GPO0 | 0 | IO | 0 | Off / Off / Off | Off / Off / Off | 7 | 1.8V / 3.3V | VDDSHV2 | Yes | LVC MOS | PU/PD |
| | | | PRG1_PRU0_GPI0 | 1 | I | 0 | | | | | | | | |
| | | | PRG1_RGMII1_RD0 | 2 | I | 0 | | | | | | | | |
| | | | PRG1_PWM3_A0 | 3 | IO | 0 | | | | | | | | |
| | | | GPIO0_45 | 7 | IO | pad | | | | | | | | |
| | | | GPMC0_AD16 | 8 | IO | 0 | | | | | | | | |
| U8 | W5 | PRG1_PRU0_GPO1 PADCONFIG: PADCONFIG47 0x000F40BC | PRG1_PRU0_GPO1 | 0 | IO | 0 | Off / Off / Off | Off / Off / Off | 7 | 1.8V / 3.3V | VDDSHV2 | Yes | LVC MOS | PU/PD |
| | | | PRG1_PRU0_GPI1 | 1 | I | 0 | | | | | | | | |
| | | | PRG1_RGMII1_RD1 | 2 | I | 0 | | | | | | | | |
| | | | PRG1_PWM3_B0 | 3 | IO | 1 | | | | | | | | |
| | | | GPIO0_46 | 7 | IO | pad | | | | | | | | |
| | | | GPMC0_AD17 | 8 | IO | 0 | | | | | | | | |
| W8 | AA4 | PRG1_PRU0_GPO2 PADCONFIG: PADCONFIG48 0x000F40C0 | PRG1_PRU0_GPO2 | 0 | IO | 0 | Off / Off / Off | Off / Off / Off | 7 | 1.8V / 3.3V | VDDSHV2 | Yes | LVC MOS | PU/PD |
| | | | PRG1_PRU0_GPI2 | 1 | I | 0 | | | | | | | | |
| | | | PRG1_RGMII1_RD2 | 2 | I | 0 | | | | | | | | |
| | | | PRG1_PWM2_A0 | 3 | IO | 0 | | | | | | | | |
| | | | GPIO0_47 | 7 | IO | pad | | | | | | | | |
| | | | GPMC0_AD18 | 8 | IO | 0 | | | | | | | | |
| V8 | Y5 | PRG1_PRU0_GPO3 PADCONFIG: PADCONFIG49 0x000F40C4 | PRG1_PRU0_GPO3 | 0 | IO | 0 | Off / Off / Off | Off / Off / Off | 7 | 1.8V / 3.3V | VDDSHV2 | Yes | LVC MOS | PU/PD |
| | | | PRG1_PRU0_GPI3 | 1 | I | 0 | | | | | | | | |
| | | | PRG1_RGMII1_RD3 | 2 | I | 0 | | | | | | | | |
| | | | PRG1_PWM3_A2 | 3 | IO | 0 | | | | | | | | |
| | | | GPIO0_48 | 7 | IO | pad | | | | | | | | |
| | | | GPMC0_AD19 | 8 | IO | 0 | | | | | | | | |
| Y8 | AA5 | PRG1_PRU0_GPO4 PADCONFIG: PADCONFIG50 0x000F40C8 | PRG1_PRU0_GPO4 | 0 | IO | 0 | Off / Off / Off | Off / Off / Off | 7 | 1.8V / 3.3V | VDDSHV2 | Yes | LVC MOS | PU/PD |
| | | | PRG1_PRU0_GPI4 | 1 | I | 0 | | | | | | | | |
| | | | PRG1_RGMII1_RX_CTL | 2 | I | 0 | | | | | | | | |
| | | | PRG1_PWM2_B0 | 3 | IO | 1 | | | | | | | | |
| | | | GPIO0_49 | 7 | IO | pad | | | | | | | | |
| | | | GPMC0_AD20 | 8 | IO | 0 | | | | | | | | |

Table 5-1. Pin Attributes (ALV, ANI, ALX Packages) (continued)

| ALV ANI BALL NUMBER [1] | ALX BALL NUMBER [1] | BALL NAME [2] PADCONFIG Register [15] PADCONFIG Address [16] | SIGNAL NAME [3] | MUX MODE [4] | TYPE [5] | DSIS [6] | BALL STATE DURING RESET RX/TX/PULL [7] | BALL STATE AFTER RESET RX/TX/PULL [8] | MUX MODE AFTER RESET [9] | IO OPERATING VOLTAGE [10] | POWER [11] | HYS [12] | BUFFER TYPE [14] | Pull UP/DOWN TYPE [13] |
|-------------------------|---------------------|--|------------------------------|--------------|----------|----------|--|---------------------------------------|--------------------------|---------------------------|------------|----------|------------------|------------------------|
| V13 | U14 | PRG1_PRU0_GPO5 PADCONFIG: PADCONFIG51 0x000F40CC | PRG1_PRU0_GPO5 | 0 | IO | 0 | Off / Off / Off | Off / Off / Off | 7 | 1.8V / 3.3V | VDDSHV2 | Yes | LVCMOS | PU/PD |
| | | | PRG1_PRU0_GPI5 | 1 | I | 0 | | | | | | | | |
| | | | PRG1_PWM3_B2 | 3 | IO | 1 | | | | | | | | |
| | | | RGMII1_RX_CTL | 4 | I | 0 | | | | | | | | |
| | | | GPIO0_50 | 7 | IO | pad | | | | | | | | |
| GPMC0_AD21 | 8 | IO | 0 | | | | | | | | | | | |
| AA7 | Y2 | PRG1_PRU0_GPO6 PADCONFIG: PADCONFIG52 0x000F40D0 | PRG1_PRU0_GPO6 | 0 | IO | 0 | Off / Off / Off | Off / Off / Off | 7 | 1.8V / 3.3V | VDDSHV2 | Yes | LVCMOS | PU/PD |
| | | | PRG1_PRU0_GPI6 | 1 | I | 0 | | | | | | | | |
| | | | PRG1_RGMII1_RXC | 2 | I | 0 | | | | | | | | |
| | | | PRG1_PWM3_A1 | 3 | IO | 0 | | | | | | | | |
| | | | GPIO0_51 | 7 | IO | pad | | | | | | | | |
| GPMC0_AD22 | 8 | IO | 0 | | | | | | | | | | | |
| U13 | V13 | PRG1_PRU0_GPO7 PADCONFIG: PADCONFIG53 0x000F40D4 | PRG1_PRU0_GPO7 | 0 | IO | 0 | Off / Off / Off | Off / Off / Off | 7 | 1.8V / 3.3V | VDDSHV2 | Yes | LVCMOS | PU/PD |
| | | | PRG1_PRU0_GPI7 | 1 | I | 0 | | | | | | | | |
| | | | PRG1_IEP0_EDC_LATCH_IN1 | 2 | I | 0 | | | | | | | | |
| | | | PRG1_PWM3_B1 | 3 | IO | 1 | | | | | | | | |
| | | | CPTS0_HW2TSPUSH | 4 | I | 0 | | | | | | | | |
| | | | CLKOUT0 | 5 | O | | | | | | | | | |
| | | | TIMER_IO10 | 6 | IO | 0 | | | | | | | | |
| | | | GPIO0_52 | 7 | IO | pad | | | | | | | | |
| GPMC0_AD23 | 8 | IO | 0 | | | | | | | | | | | |
| W13 | Y13 | PRG1_PRU0_GPO8 PADCONFIG: PADCONFIG54 0x000F40D8 | PRG1_PRU0_GPO8 | 0 | IO | 0 | Off / Off / Off | Off / Off / Off | 7 | 1.8V / 3.3V | VDDSHV2 | Yes | LVCMOS | PU/PD |
| | | | PRG1_PRU0_GPI8 | 1 | I | 0 | | | | | | | | |
| | | | PRG1_PWM2_A1 | 3 | IO | 0 | | | | | | | | |
| | | | RGMII1_RXC | 4 | I | 0 | | | | | | | | |
| | | | GPIO0_53 | 7 | IO | pad | | | | | | | | |
| GPMC0_AD24 | 8 | IO | 0 | | | | | | | | | | | |
| U15 | W16 | PRG1_PRU0_GPO9 PADCONFIG: PADCONFIG55 0x000F40DC | PRG1_PRU0_GPO9 | 0 | IO | 0 | Off / Off / Off | Off / Off / Off | 7 | 1.8V / 3.3V | VDDSHV2 | Yes | LVCMOS | PU/PD |
| | | | PRG1_PRU0_GPI9 | 1 | I | 0 | | | | | | | | |
| | | | PRG1_UART0_CTSn | 2 | I | 1 | | | | | | | | |
| | | | PRG1_PWM3_TZ_IN | 3 | I | 0 | | | | | | | | |
| | | | RGMII1_TX_CTL | 4 | O | | | | | | | | | |
| | | | RMII1_RX_ER | 5 | I | 0 | | | | | | | | |
| | | | PRG1_IEP0_EDIO_DATA_IN_OUT28 | 6 | IO | 0 | | | | | | | | |
| | | | GPIO0_54 | 7 | IO | pad | | | | | | | | |
| GPMC0_AD25 | 8 | IO | 0 | | | | | | | | | | | |

Table 5-1. Pin Attributes (ALV, ANI, ALX Packages) (continued)

| ALV ANI BALL NUMBER [1] | ALX BALL NUMBER [1] | BALL NAME [2] PADCONFIG Register [15] PADCONFIG Address [16] | SIGNAL NAME [3] | MUX MODE [4] | TYPE [5] | DSIS [6] | BALL STATE DURING RESET RX/TX/PULL [7] | BALL STATE AFTER RESET RX/TX/PULL [8] | MUX MODE AFTER RESET [9] | IO OPERATING VOLTAGE [10] | POWER [11] | HYS [12] | BUFFER TYPE [14] | Pull UP/DOWN TYPE [13] |
|-------------------------|---------------------|--|------------------------------|--------------|----------|----------|--|---------------------------------------|--------------------------|---------------------------|------------|----------|------------------|------------------------|
| U14 | W13 | PRG1_PRU0_GPO10 PADCONFIG: PADCONFIG56 0x000F40E0 | PRG1_PRU0_GPO10 | 0 | IO | 0 | Off / Off / Off | Off / Off / Off | 7 | 1.8V / 3.3V | VDDSHV2 | Yes | LVCMOS | PU/PD |
| | | | PRG1_PRU0_GPI10 | 1 | I | 0 | | | | | | | | |
| | | | PRG1_UART0_RTSn | 2 | O | | | | | | | | | |
| | | | PRG1_PWM2_B1 | 3 | IO | 1 | | | | | | | | |
| | | | RGMI1_TXC | 4 | IO | 0 | | | | | | | | |
| | | | RMII_REF_CLK | 5 | I | 0 | | | | | | | | |
| | | | PRG1_IEP0_EDIO_DATA_IN_OUT29 | 6 | IO | 0 | | | | | | | | |
| | | | GPI00_55 | 7 | IO | pad | | | | | | | | |
| AA8 | V5 | PRG1_PRU0_GPO11 PADCONFIG: PADCONFIG57 0x000F40E4 | PRG1_PRU0_GPO11 | 0 | IO | 0 | Off / Off / Off | Off / Off / Off | 7 | 1.8V / 3.3V | VDDSHV2 | Yes | LVCMOS | PU/PD |
| | | | PRG1_PRU0_GPI11 | 1 | I | 0 | | | | | | | | |
| | | | PRG1_RGMII1_TD0 | 2 | O | | | | | | | | | |
| | | | PRG1_PWM3_TZ_OUT | 3 | O | | | | | | | | | |
| | | | GPI00_56 | 7 | IO | pad | | | | | | | | |
| | | | GPMC0_AD27 | 8 | IO | 0 | | | | | | | | |
| U9 | W2 | PRG1_PRU0_GPO12 PADCONFIG: PADCONFIG58 0x000F40E8 | PRG1_PRU0_GPO12 | 0 | IO | 0 | Off / Off / Off | Off / Off / Off | 7 | 1.8V / 3.3V | VDDSHV2 | Yes | LVCMOS | PU/PD |
| | | | PRG1_PRU0_GPI12 | 1 | I | 0 | | | | | | | | |
| | | | PRG1_RGMII1_TD1 | 2 | O | | | | | | | | | |
| | | | PRG1_PWM0_A0 | 3 | IO | 0 | | | | | | | | |
| | | | GPI00_57 | 7 | IO | pad | | | | | | | | |
| | | | GPMC0_AD28 | 8 | IO | 0 | | | | | | | | |
| W9 | V6 | PRG1_PRU0_GPO13 PADCONFIG: PADCONFIG59 0x000F40EC | PRG1_PRU0_GPO13 | 0 | IO | 0 | Off / Off / Off | Off / Off / Off | 7 | 1.8V / 3.3V | VDDSHV2 | Yes | LVCMOS | PU/PD |
| | | | PRG1_PRU0_GPI13 | 1 | I | 0 | | | | | | | | |
| | | | PRG1_RGMII1_TD2 | 2 | O | | | | | | | | | |
| | | | PRG1_PWM0_B0 | 3 | IO | 1 | | | | | | | | |
| | | | GPI00_58 | 7 | IO | pad | | | | | | | | |
| | | | GPMC0_AD29 | 8 | IO | 0 | | | | | | | | |
| AA9 | AA7 | PRG1_PRU0_GPO14 PADCONFIG: PADCONFIG60 0x000F40F0 | PRG1_PRU0_GPO14 | 0 | IO | 0 | Off / Off / Off | Off / Off / Off | 7 | 1.8V / 3.3V | VDDSHV2 | Yes | LVCMOS | PU/PD |
| | | | PRG1_PRU0_GPI14 | 1 | I | 0 | | | | | | | | |
| | | | PRG1_RGMII1_TD3 | 2 | O | | | | | | | | | |
| | | | PRG1_PWM0_A1 | 3 | IO | 0 | | | | | | | | |
| | | | GPI00_59 | 7 | IO | pad | | | | | | | | |
| | | | GPMC0_AD30 | 8 | IO | 0 | | | | | | | | |

Table 5-1. Pin Attributes (ALV, ANI, ALX Packages) (continued)

| ALV ANI BALL NUMBER [1] | ALX BALL NUMBER [1] | BALL NAME [2] PADCONFIG Register [15] PADCONFIG Address [16] | SIGNAL NAME [3] | MUX MODE [4] | TYPE [5] | DSIS [6] | BALL STATE DURING RESET RX/TX/PULL [7] | BALL STATE AFTER RESET RX/TX/PULL [8] | MUX MODE AFTER RESET [9] | IO OPERATING VOLTAGE [10] | POWER [11] | HYS [12] | BUFFER TYPE [14] | Pull UP/DOWN TYPE [13] |
|-------------------------|---------------------|--|-------------------------|--------------|----------|----------|--|---------------------------------------|--------------------------|---------------------------|------------|----------|------------------|------------------------|
| Y9 | Y7 | PRG1_PRU0_GPO15 PADCONFIG: PADCONFIG61 0x000F40F4 | PRG1_PRU0_GPO15 | 0 | IO | 0 | Off / Off / Off | Off / Off / Off | 7 | 1.8V / 3.3V | VDDSHV2 | Yes | LVCMOS | PU/PD |
| | | | PRG1_PRU0_GPI15 | 1 | I | 0 | | | | | | | | |
| | | | PRG1_RGMII1_TX_CTL | 2 | O | | | | | | | | | |
| | | | PRG1_PWM0_B1 | 3 | IO | 1 | | | | | | | | |
| | | | GPIO0_60 | 7 | IO | pad | | | | | | | | |
| | | | GPMC0_AD31 | 8 | IO | 0 | | | | | | | | |
| V9 | W6 | PRG1_PRU0_GPO16 PADCONFIG: PADCONFIG62 0x000F40F8 | PRG1_PRU0_GPO16 | 0 | IO | 0 | Off / Off / Off | Off / Off / Off | 7 | 1.8V / 3.3V | VDDSHV2 | Yes | LVCMOS | PU/PD |
| | | | PRG1_PRU0_GPI16 | 1 | I | 0 | | | | | | | | |
| | | | PRG1_RGMII1_TXC | 2 | IO | 0 | | | | | | | | |
| | | | PRG1_PWM0_A2 | 3 | IO | 0 | | | | | | | | |
| | | | GPIO0_61 | 7 | IO | pad | | | | | | | | |
| | | | GPMC0_BE2n | 8 | O | | | | | | | | | |
| U7 | T2 | PRG1_PRU0_GPO17 PADCONFIG: PADCONFIG63 0x000F40FC | PRG1_PRU0_GPO17 | 0 | IO | 0 | Off / Off / Off | Off / Off / Off | 7 | 1.8V / 3.3V | VDDSHV2 | Yes | LVCMOS | PU/PD |
| | | | PRG1_PRU0_GPI17 | 1 | I | 0 | | | | | | | | |
| | | | PRG1_IEP0_EDC_SYNC_OUT1 | 2 | O | | | | | | | | | |
| | | | PRG1_PWM0_B2 | 3 | IO | 1 | | | | | | | | |
| | | | CPTS0_TS_SYNC | 4 | O | | | | | | | | | |
| | | | TIMER_IO7 | 6 | IO | 0 | | | | | | | | |
| | | | GPIO0_62 | 7 | IO | pad | | | | | | | | |
| | | | GPMC0_A0 | 8 | OZ | | | | | | | | | |
| V7 | Y4 | PRG1_PRU0_GPO18 PADCONFIG: PADCONFIG64 0x000F4100 | PRG1_PRU0_GPO18 | 0 | IO | 0 | Off / Off / Off | Off / Off / Off | 7 | 1.8V / 3.3V | VDDSHV2 | Yes | LVCMOS | PU/PD |
| | | | PRG1_PRU0_GPI18 | 1 | I | 0 | | | | | | | | |
| | | | PRG1_IEP0_EDC_LATCH_IN0 | 2 | I | 0 | | | | | | | | |
| | | | PRG1_PWM0_TZ_IN | 3 | I | 0 | | | | | | | | |
| | | | CPTS0_HW1TSPUSH | 4 | I | 0 | | | | | | | | |
| | | | TIMER_IO8 | 6 | IO | 0 | | | | | | | | |
| | | | GPIO0_63 | 7 | IO | pad | | | | | | | | |
| | | | GPMC0_A1 | 8 | OZ | | | | | | | | | |
| W7 | U3 | PRG1_PRU0_GPO19 PADCONFIG: PADCONFIG65 0x000F4104 | PRG1_PRU0_GPO19 | 0 | IO | 0 | Off / Off / Off | Off / Off / Off | 7 | 1.8V / 3.3V | VDDSHV2 | Yes | LVCMOS | PU/PD |
| | | | PRG1_PRU0_GPI19 | 1 | I | 0 | | | | | | | | |
| | | | PRG1_IEP0_EDC_SYNC_OUT0 | 2 | O | | | | | | | | | |
| | | | PRG1_PWM0_TZ_OUT | 3 | O | | | | | | | | | |
| | | | CPTS0_TS_COMP | 4 | O | | | | | | | | | |
| | | | TIMER_IO9 | 6 | IO | 0 | | | | | | | | |
| | | | GPIO0_64 | 7 | IO | pad | | | | | | | | |
| | | | GPMC0_A2 | 8 | OZ | | | | | | | | | |

Table 5-1. Pin Attributes (ALV, ANI, ALX Packages) (continued)

| ALV ANI BALL NUMBER [1] | ALX BALL NUMBER [1] | BALL NAME [2] PADCONFIG Register [15] PADCONFIG Address [16] | SIGNAL NAME [3] | MUX MODE [4] | TYPE [5] | DSIS [6] | BALL STATE DURING RESET RX/TX/PULL [7] | BALL STATE AFTER RESET RX/TX/PULL [8] | MUX MODE AFTER RESET [9] | IO OPERATING VOLTAGE [10] | POWER [11] | HYS [12] | BUFFER TYPE [14] | Pull UP/DOWN TYPE [13] |
|-------------------------|---------------------|--|--------------------|--------------|----------|----------|--|---------------------------------------|--------------------------|---------------------------|------------|----------|------------------|------------------------|
| W11 | AA10 | PRG1_PRU1_GPO0 PADCONFIG: PADCONFIG66 0x000F4108 | PRG1_PRU1_GPO0 | 0 | IO | 0 | Off / Off / Off | Off / Off / Off | 7 | 1.8V / 3.3V | VDDSHV2 | Yes | LVCMOS | PU/PD |
| | | | PRG1_PRU1_GPI0 | 1 | I | 0 | | | | | | | | |
| | | | PRG1_RGMII2_RD0 | 2 | I | 0 | | | | | | | | |
| | | | RGMII2_RD0 | 4 | I | 0 | | | | | | | | |
| | | | RMII2_RXD0 | 5 | I | 0 | | | | | | | | |
| | | | GPIO0_65 | 7 | IO | pad | | | | | | | | |
| | | | GPMC0_A3 | 8 | OZ | | | | | | | | | |
| V11 | Y10 | PRG1_PRU1_GPO1 PADCONFIG: PADCONFIG67 0x000F410C | PRG1_PRU1_GPO1 | 0 | IO | 0 | Off / Off / Off | Off / Off / Off | 7 | 1.8V / 3.3V | VDDSHV2 | Yes | LVCMOS | PU/PD |
| | | | PRG1_PRU1_GPI1 | 1 | I | 0 | | | | | | | | |
| | | | PRG1_RGMII2_RD1 | 2 | I | 0 | | | | | | | | |
| | | | RGMII2_RD1 | 4 | I | 0 | | | | | | | | |
| | | | RMII2_RXD1 | 5 | I | 0 | | | | | | | | |
| | | | GPIO0_66 | 7 | IO | pad | | | | | | | | |
| | | | GPMC0_A4 | 8 | OZ | | | | | | | | | |
| AA12 | Y11 | PRG1_PRU1_GPO2 PADCONFIG: PADCONFIG68 0x000F4110 | PRG1_PRU1_GPO2 | 0 | IO | 0 | Off / Off / Off | Off / Off / Off | 7 | 1.8V / 3.3V | VDDSHV2 | Yes | LVCMOS | PU/PD |
| | | | PRG1_PRU1_GPI2 | 1 | I | 0 | | | | | | | | |
| | | | PRG1_RGMII2_RD2 | 2 | I | 0 | | | | | | | | |
| | | | PRG1_PWM2_A2 | 3 | IO | 0 | | | | | | | | |
| | | | RGMII2_RD2 | 4 | I | 0 | | | | | | | | |
| | | | GPIO0_67 | 7 | IO | pad | | | | | | | | |
| | | | GPMC0_A5 | 8 | OZ | | | | | | | | | |
| Y12 | V12 | PRG1_PRU1_GPO3 PADCONFIG: PADCONFIG69 0x000F4114 | PRG1_PRU1_GPO3 | 0 | IO | 0 | Off / Off / Off | Off / Off / Off | 7 | 1.8V / 3.3V | VDDSHV2 | Yes | LVCMOS | PU/PD |
| | | | PRG1_PRU1_GPI3 | 1 | I | 0 | | | | | | | | |
| | | | PRG1_RGMII2_RD3 | 2 | I | 0 | | | | | | | | |
| | | | RGMII2_RD3 | 4 | I | 0 | | | | | | | | |
| | | | GPIO0_68 | 7 | IO | pad | | | | | | | | |
| | | | GPMC0_A6 | 8 | OZ | | | | | | | | | |
| W12 | Y12 | PRG1_PRU1_GPO4 PADCONFIG: PADCONFIG70 0x000F4118 | PRG1_PRU1_GPO4 | 0 | IO | 0 | Off / Off / Off | Off / Off / Off | 7 | 1.8V / 3.3V | VDDSHV2 | Yes | LVCMOS | PU/PD |
| | | | PRG1_PRU1_GPI4 | 1 | I | 0 | | | | | | | | |
| | | | PRG1_RGMII2_RX_CTL | 2 | I | 0 | | | | | | | | |
| | | | PRG1_PWM2_B2 | 3 | IO | 1 | | | | | | | | |
| | | | RGMII2_RX_CTL | 4 | I | 0 | | | | | | | | |
| | | | RMII2_RX_ER | 5 | I | 0 | | | | | | | | |
| | | | GPIO0_69 | 7 | IO | pad | | | | | | | | |
| | | | GPMC0_A7 | 8 | OZ | | | | | | | | | |

Table 5-1. Pin Attributes (ALV, ANI, ALX Packages) (continued)

| ALV ANI BALL NUMBER [1] | ALX BALL NUMBER [1] | BALL NAME [2] PADCONFIG Register [15] PADCONFIG Address [16] | SIGNAL NAME [3] | MUX MODE [4] | TYPE [5] | DSIS [6] | BALL STATE DURING RESET RX/TX/PULL [7] | BALL STATE AFTER RESET RX/TX/PULL [8] | MUX MODE AFTER RESET [9] | IO OPERATING VOLTAGE [10] | POWER [11] | HYS [12] | BUFFER TYPE [14] | Pull UP/DOWN TYPE [13] |
|-------------------------|---------------------|--|------------------------------|--------------|----------|----------|--|---------------------------------------|--------------------------|---------------------------|------------|----------|------------------|------------------------|
| AA13 | AA11 | PRG1_PRU1_GPO5 PADCONFIG: PADCONFIG71 0x000F411C | PRG1_PRU1_GPO5 | 0 | IO | 0 | Off / Off / Off | Off / Off / Off | 7 | 1.8V / 3.3V | VDDSHV2 | Yes | LVCMOS | PU/PD |
| | | | PRG1_PRU1_GPI5 | 1 | I | 0 | | | | | | | | |
| | | | RGMII1_RD0 | 4 | I | 0 | | | | | | | | |
| | | | GPIO0_70 | 7 | IO | pad | | | | | | | | |
| | | | GPMC0_A8 | 8 | OZ | | | | | | | | | |
| U11 | V10 | PRG1_PRU1_GPO6 PADCONFIG: PADCONFIG72 0x000F4120 | PRG1_PRU1_GPO6 | 0 | IO | 0 | Off / Off / Off | Off / Off / Off | 7 | 1.8V / 3.3V | VDDSHV2 | Yes | LVCMOS | PU/PD |
| | | | PRG1_PRU1_GPI6 | 1 | I | 0 | | | | | | | | |
| | | | PRG1_RGMII2_RXC | 2 | I | 0 | | | | | | | | |
| | | | RGMII2_RXC | 4 | I | 0 | | | | | | | | |
| | | | GPIO0_71 | 7 | IO | pad | | | | | | | | |
| | | | GPMC0_A9 | 8 | OZ | | | | | | | | | |
| V15 | Y14 | PRG1_PRU1_GPO7 PADCONFIG: PADCONFIG73 0x000F4124 | PRG1_PRU1_GPO7 | 0 | IO | 0 | Off / Off / Off | Off / Off / Off | 7 | 1.8V / 3.3V | VDDSHV2 | Yes | LVCMOS | PU/PD |
| | | | PRG1_PRU1_GPI7 | 1 | I | 0 | | | | | | | | |
| | | | PRG1_IEP1_EDC_LATCH_IN1 | 2 | I | 0 | | | | | | | | |
| | | | RGMII1_TD0 | 4 | O | | | | | | | | | |
| | | | RMII1_RXD0 | 5 | I | 0 | | | | | | | | |
| | | | SPI3_CS3 | 6 | IO | 1 | | | | | | | | |
| | | | GPIO0_72 | 7 | IO | pad | | | | | | | | |
| | | | GPMC0_A10 | 8 | OZ | | | | | | | | | |
| U12 | W11 | PRG1_PRU1_GPO8 PADCONFIG: PADCONFIG74 0x000F4128 | PRG1_PRU1_GPO8 | 0 | IO | 0 | Off / Off / Off | Off / Off / Off | 7 | 1.8V / 3.3V | VDDSHV2 | Yes | LVCMOS | PU/PD |
| | | | PRG1_PRU1_GPI8 | 1 | I | 0 | | | | | | | | |
| | | | PRG1_PWM2_TZ_OUT | 3 | O | | | | | | | | | |
| | | | RGMII1_RD1 | 4 | I | 0 | | | | | | | | |
| | | | GPIO0_73 | 7 | IO | pad | | | | | | | | |
| | | | GPMC0_A11 | 8 | OZ | | | | | | | | | |
| V14 | Y16 | PRG1_PRU1_GPO9 PADCONFIG: PADCONFIG75 0x000F412C | PRG1_PRU1_GPO9 | 0 | IO | 0 | Off / Off / Off | Off / Off / Off | 7 | 1.8V / 3.3V | VDDSHV2 | Yes | LVCMOS | PU/PD |
| | | | PRG1_PRU1_GPI9 | 1 | I | 0 | | | | | | | | |
| | | | PRG1_UART0_RXD | 2 | I | 1 | | | | | | | | |
| | | | RGMII1_TD1 | 4 | O | | | | | | | | | |
| | | | RMII1_RXD1 | 5 | I | 0 | | | | | | | | |
| | | | PRG1_IEP0_EDIO_DATA_IN_OUT30 | 6 | IO | 0 | | | | | | | | |
| | | | GPIO0_74 | 7 | IO | pad | | | | | | | | |
| | | | GPMC0_A12 | 8 | OZ | | | | | | | | | |

Table 5-1. Pin Attributes (ALV, ANI, ALX Packages) (continued)

| ALV ANI BALL NUMBER [1] | ALX BALL NUMBER [1] | BALL NAME [2] PADCONFIG Register [15] PADCONFIG Address [16] | SIGNAL NAME [3] | MUX MODE [4] | TYPE [5] | DSIS [6] | BALL STATE DURING RESET RX/TX/PULL [7] | BALL STATE AFTER RESET RX/TX/PULL [8] | MUX MODE AFTER RESET [9] | IO OPERATING VOLTAGE [10] | POWER [11] | HYS [12] | BUFFER TYPE [14] | Pull UP/DOWN TYPE [13] |
|-------------------------|---------------------|--|------------------------------|--------------|--|-----------------|--|---------------------------------------|--------------------------|---------------------------|------------|----------|------------------|------------------------|
| W14 | U13 | PRG1_PRU1_GPO10 PADCONFIG: PADCONFIG76 0x000F4130 | PRG1_PRU1_GPO10 | 0 | IO | 0 | Off / Off / Off | Off / Off / Off | 7 | 1.8V / 3.3V | VDDSHV2 | Yes | LVCMOS | PU/PD |
| | | | PRG1_PRU1_GPI10 | 1 | I | 0 | | | | | | | | |
| | | | PRG1_UART0_TXD | 2 | O | | | | | | | | | |
| | | | PRG1_PWM2_TZ_IN | 3 | I | 0 | | | | | | | | |
| | | | RGMII1_TD2 | 4 | O | | | | | | | | | |
| | | | RMII1_TXD0 | 5 | O | | | | | | | | | |
| | | | PRG1_IEP0_EDIO_DATA_IN_OUT31 | 6 | IO | 0 | | | | | | | | |
| | | | GPI00_75 | 7 | IO | pad | | | | | | | | |
| GPMC0_A13 | 8 | OZ | | | | | | | | | | | | |
| AA10 | Y6 | PRG1_PRU1_GPO11 PADCONFIG: PADCONFIG77 0x000F4134 | PRG1_PRU1_GPO11 | 0 | IO | 0 | Off / Off / Off | Off / Off / Off | 7 | 1.8V / 3.3V | VDDSHV2 | Yes | LVCMOS | PU/PD |
| | | | PRG1_PRU1_GPI11 | 1 | I | 0 | | | | | | | | |
| | | | PRG1_RGMII2_TD0 | 2 | O | | | | | | | | | |
| | | | RGMII2_TD0 | 4 | O | | | | | | | | | |
| | | | RMII2_TXD0 | 5 | O | | | | | | | | | |
| | | | GPI00_76 | 7 | IO | pad | | | | | | | | |
| | | | GPMC0_A14 | 8 | OZ | | | | | | | | | |
| | | | V10 | AA8 | PRG1_PRU1_GPO12 PADCONFIG: PADCONFIG78 0x000F4138 | PRG1_PRU1_GPO12 | | | | | | | | |
| PRG1_PRU1_GPI12 | 1 | I | | | | 0 | | | | | | | | |
| PRG1_RGMII2_TD1 | 2 | O | | | | | | | | | | | | |
| PRG1_PWM1_A0 | 3 | IO | | | | 0 | | | | | | | | |
| RGMII2_TD1 | 4 | O | | | | | | | | | | | | |
| RMII2_TXD1 | 5 | O | | | | | | | | | | | | |
| GPI00_77 | 7 | IO | | | | pad | | | | | | | | |
| GPMC0_A15 | 8 | OZ | | | | | | | | | | | | |
| U10 | Y9 | PRG1_PRU1_GPO13 PADCONFIG: PADCONFIG79 0x000F413C | PRG1_PRU1_GPO13 | 0 | IO | 0 | Off / Off / Off | Off / Off / Off | 7 | 1.8V / 3.3V | VDDSHV2 | Yes | LVCMOS | PU/PD |
| | | | PRG1_PRU1_GPI13 | 1 | I | 0 | | | | | | | | |
| | | | PRG1_RGMII2_TD2 | 2 | O | | | | | | | | | |
| | | | PRG1_PWM1_B0 | 3 | IO | 1 | | | | | | | | |
| | | | RGMII2_TD2 | 4 | O | | | | | | | | | |
| | | | RMII2_CRD_DV | 5 | I | 0 | | | | | | | | |
| | | | GPI00_78 | 7 | IO | pad | | | | | | | | |
| | | | GPMC0_A16 | 8 | OZ | | | | | | | | | |

Table 5-1. Pin Attributes (ALV, ANI, ALX Packages) (continued)

| ALV ANI BALL NUMBER [1] | ALX BALL NUMBER [1] | BALL NAME [2] PADCONFIG Register [15] PADCONFIG Address [16] | SIGNAL NAME [3] | MUX MODE [4] | TYPE [5] | DSIS [6] | BALL STATE DURING RESET RX/TX/PULL [7] | BALL STATE AFTER RESET RX/TX/PULL [8] | MUX MODE AFTER RESET [9] | IO OPERATING VOLTAGE [10] | POWER [11] | HYS [12] | BUFFER TYPE [14] | Pull UP/DOWN TYPE [13] |
|-------------------------|---------------------|--|-------------------------|--------------|----------|----------|--|---------------------------------------|--------------------------|---------------------------|------------|----------|------------------|------------------------|
| AA11 | W9 | PRG1_PRU1_GPO14 PADCONFIG: PADCONFIG80 0x000F4140 | PRG1_PRU1_GPO14 | 0 | IO | 0 | Off / Off / Off | Off / Off / Off | 7 | 1.8V / 3.3V | VDDSHV2 | Yes | LVCMOS | PU/PD |
| | | | PRG1_PRU1_GPI14 | 1 | I | 0 | | | | | | | | |
| | | | PRG1_RGMII2_TD3 | 2 | O | | | | | | | | | |
| | | | PRG1_PWM1_A1 | 3 | IO | 0 | | | | | | | | |
| | | | RGMII2_TD3 | 4 | O | | | | | | | | | |
| | | | GPIO_79 | 7 | IO | pad | | | | | | | | |
| | | | GPMC0_A17 | 8 | OZ | | | | | | | | | |
| Y11 | V9 | PRG1_PRU1_GPO15 PADCONFIG: PADCONFIG81 0x000F4144 | PRG1_PRU1_GPO15 | 0 | IO | 0 | Off / Off / Off | Off / Off / Off | 7 | 1.8V / 3.3V | VDDSHV2 | Yes | LVCMOS | PU/PD |
| | | | PRG1_PRU1_GPI15 | 1 | I | 0 | | | | | | | | |
| | | | PRG1_RGMII2_TX_CTL | 2 | O | | | | | | | | | |
| | | | PRG1_PWM1_B1 | 3 | IO | 1 | | | | | | | | |
| | | | RGMII2_TX_CTL | 4 | O | | | | | | | | | |
| | | | RMII2_TX_EN | 5 | O | | | | | | | | | |
| | | | GPIO_80 | 7 | IO | pad | | | | | | | | |
| GPMC0_A18 | 8 | OZ | | | | | | | | | | | | |
| Y10 | Y8 | PRG1_PRU1_GPO16 PADCONFIG: PADCONFIG82 0x000F4148 | PRG1_PRU1_GPO16 | 0 | IO | 0 | Off / Off / Off | Off / Off / Off | 7 | 1.8V / 3.3V | VDDSHV2 | Yes | LVCMOS | PU/PD |
| | | | PRG1_PRU1_GPI16 | 1 | I | 0 | | | | | | | | |
| | | | PRG1_RGMII2_TXC | 2 | IO | 0 | | | | | | | | |
| | | | PRG1_PWM1_A2 | 3 | IO | 0 | | | | | | | | |
| | | | RGMII2_TXC | 4 | IO | 0 | | | | | | | | |
| | | | GPIO_81 | 7 | IO | pad | | | | | | | | |
| | | | GPMC0_A19 | 8 | OZ | | | | | | | | | |
| AA14 | AA14 | PRG1_PRU1_GPO17 PADCONFIG: PADCONFIG83 0x000F414C | PRG1_PRU1_GPO17 | 0 | IO | 0 | Off / Off / Off | Off / Off / Off | 7 | 1.8V / 3.3V | VDDSHV2 | Yes | LVCMOS | PU/PD |
| | | | PRG1_PRU1_GPI17 | 1 | I | 0 | | | | | | | | |
| | | | PRG1_IEP1_EDC_SYNC_OUT1 | 2 | O | | | | | | | | | |
| | | | PRG1_PWM1_B2 | 3 | IO | 1 | | | | | | | | |
| | | | RGMII1_TD3 | 4 | O | | | | | | | | | |
| | | | RMII1_TXD1 | 5 | O | | | | | | | | | |
| | | | GPIO_19 | 7 | IO | pad | | | | | | | | |
| | | | GPMC0_BE3n | 8 | O | | | | | | | | | |
| PRG1_ECAP0_SYNC_OUT | 9 | O | | | | | | | | | | | | |

Table 5-1. Pin Attributes (ALV, ANI, ALX Packages) (continued)

| ALV ANI BALL NUMBER [1] | ALX BALL NUMBER [1] | BALL NAME [2] PADCONFIG Register [15] PADCONFIG Address [16] | SIGNAL NAME [3] | MUX MODE [4] | TYPE [5] | DSIS [6] | BALL STATE DURING RESET RX/TX/PULL [7] | BALL STATE AFTER RESET RX/TX/PULL [8] | MUX MODE AFTER RESET [9] | IO OPERATING VOLTAGE [10] | POWER [11] | HYS [12] | BUFFER TYPE [14] | Pull UP/DOWN TYPE [13] |
|-------------------------|---------------------|--|-------------------------|--------------|----------|----------|--|---------------------------------------|--------------------------|---------------------------|------------------|----------|------------------|------------------------|
| Y13 | Y15 | PRG1_PRU1_GPO18 PADCONFIG: PADCONFIG84 0x000F4150 | PRG1_PRU1_GPO18 | 0 | IO | 0 | Off / Off / Off | Off / Off / Off | 7 | 1.8V / 3.3V | VDDSHV2 | Yes | LVCMOS | PU/PD |
| | | | PRG1_PRU1_GPI18 | 1 | I | 0 | | | | | | | | |
| | | | PRG1_IEP1_EDC_LATCH_IN0 | 2 | I | 0 | | | | | | | | |
| | | | PRG1_PWM1_TZ_IN | 3 | I | 0 | | | | | | | | |
| | | | RGMII1_RD2 | 4 | I | 0 | | | | | | | | |
| | | | RMII1_TX_EN | 5 | O | | | | | | | | | |
| | | | GPIO0_20 | 7 | IO | pad | | | | | | | | |
| | | | UART5_CTSn | 8 | I | 1 | | | | | | | | |
| PRG1_ECAP0_SYNC_IN | 9 | I | 0 | | | | | | | | | | | |
| V12 | AA13 | PRG1_PRU1_GPO19 PADCONFIG: PADCONFIG85 0x000F4154 | PRG1_PRU1_GPO19 | 0 | IO | 0 | Off / Off / Off | Off / Off / Off | 7 | 1.8V / 3.3V | VDDSHV2 | Yes | LVCMOS | PU/PD |
| | | | PRG1_PRU1_GPI19 | 1 | I | 0 | | | | | | | | |
| | | | PRG1_IEP1_EDC_SYNC_OUT0 | 2 | O | | | | | | | | | |
| | | | PRG1_PWM1_TZ_OUT | 3 | O | | | | | | | | | |
| | | | RGMII1_RD3 | 4 | I | 0 | | | | | | | | |
| | | | RMII1_CRS_DV | 5 | I | 0 | | | | | | | | |
| | | | SPI3_CS2 | 6 | IO | 1 | | | | | | | | |
| | | | GPIO0_84 | 7 | IO | pad | | | | | | | | |
| UART5_RTSn | 8 | O | | | | | | | | | | | | |
| PRG1_ECAP0_IN_APWM_OUT | 9 | IO | 0 | | | | | | | | | | | |
| F16 | E19 | RESETSTATz PADCONFIG: PADCONFIG169 0x000F42A4 | RESETSTATz | 0 | O | | Off / Low / Off | Off / SS / Off | 0 | 1.8V / 3.3V | VDDSHV0 | Yes | LVCMOS | PU/PD |
| E18 | C17 | RESET_REQz PADCONFIG: PADCONFIG168 0x000F42A0 | RESET_REQz | 0 | I | | On / Off / Up | On / Off / Up | 0 | 1.8V / 3.3V | VDDSHV0 | Yes | LVCMOS | PU/PD |
| H16 | H11 | RSVD0 | RSVD0 | | N/A | | | | | | | | | |
| D21 | J13 | RSVD1 | RSVD1 | | N/A | | | | | | | | | |
| G13 | | RSVD2 | RSVD2 | | N/A | | | | | | | | | |
| F17 | | RSVD3 | RSVD3 | | N/A | | | | | | | | | |
| W15 | | RSVD4 | RSVD4 | | N/A | | | | | | | | | |
| V16 | | RSVD5 | RSVD5 | | N/A | | | | | | | | | |
| K2 | | RSVD6 | RSVD6 | | N/A | | | | | | | | | |
| K1 | | RSVD7 | RSVD7 | | N/A | | | | | | | | | |
| F12 | | RSVD8 | RSVD8 | | N/A | | | | | | | | | |
| T13 | | SERDES0_REXT | SERDES0_REXT | | A | | | | | 1.8V | VDDA_1P8_SERDES0 | | SERDES | |

Table 5-1. Pin Attributes (ALV, ANI, ALX Packages) (continued)

| ALV ANI BALL NUMBER [1] | ALX BALL NUMBER [1] | BALL NAME [2] PADCONFIG Register [15] PADCONFIG Address [16] | SIGNAL NAME [3] | MUX MODE [4] | TYPE [5] | DSIS [6] | BALL STATE DURING RESET RX/TX/PULL [7] | BALL STATE AFTER RESET RX/TX/PULL [8] | MUX MODE AFTER RESET [9] | IO OPERATING VOLTAGE [10] | POWER [11] | HYS [12] | BUFFER TYPE [14] | Pull UP/DOWN TYPE [13] |
|-------------------------------------|------------------------------|--|-------------------------|-----------------|-------------|-------------|---|--|--------------------------------------|---------------------------------|----------------------|-------------|---------------------|------------------------------|
| W16 | | SERDES0_REFCLK0N | SERDES0_REFCLK0N | | IO | | | | | 1.8V | VDDA_1P8_SERDES 0 | | SERDES | |
| W17 | | SERDES0_REFCLK0P | SERDES0_REFCLK0P | | IO | | | | | 1.8V | VDDA_1P8_SERDES 0 | | SERDES | |
| Y15 | | SERDES0_RX0_N | SERDES0_RX0_N | | I | | | | | 1.8V | VDDA_1P8_SERDES 0 | | SERDES | |
| Y16 | | SERDES0_RX0_P | SERDES0_RX0_P | | I | | | | | 1.8V | VDDA_1P8_SERDES 0 | | SERDES | |
| AA16 | | SERDES0_TX0_N | SERDES0_TX0_N | | O | | | | | 1.8V | VDDA_1P8_SERDES 0 | | SERDES | |
| AA17 | | SERDES0_TX0_P | SERDES0_TX0_P | | O | | | | | 1.8V | VDDA_1P8_SERDES 0 | | SERDES | |
| D13 | B8 | SPI0_CLK PADCONFIG: PADCONFIG132 0x000F4210 | SPI0_CLK | 0 | IO | 0 | Off / Off / Off | Off / Off / Off | 7 | 1.8V / 3.3V | VDDSHV0 | Yes | LVCMOS | PU/PD |
| | | | GPIO1_44 | 7 | IO | pad | | | | | | | | |
| C14 | | SPI1_CLK PADCONFIG: PADCONFIG137 0x000F4224 | SPI1_CLK | 0 | IO | 0 | Off / Off / Off | Off / Off / Off | 7 | 1.8V / 3.3V | VDDSHV0 | Yes | LVCMOS | PU/PD |
| | | | EHRPWM6_SYNCI | 3 | I | 0 | | | | | | | | |
| | | | GPIO1_49 | 7 | IO | pad | | | | | | | | |
| D12 | | SPI0_CS0 PADCONFIG: PADCONFIG130 0x000F4208 | SPI0_CS0 | 0 | IO | 1 | Off / Off / Off | Off / Off / Off | 7 | 1.8V / 3.3V | VDDSHV0 | Yes | LVCMOS | PU/PD |
| | | | GPIO1_42 | 7 | IO | pad | | | | | | | | |
| C13 | B7 | SPI0_CS1 PADCONFIG: PADCONFIG131 0x000F420C | SPI0_CS1 | 0 | IO | 1 | Off / Off / Off | Off / Off / Off | 7 | 1.8V / 3.3V | VDDSHV0 | Yes | LVCMOS | PU/PD |
| | | | CPTS0_TS_COMP | 1 | O | | | | | | | | | |
| | | | I2C2_SCL | 2 | IOD | 1 | | | | | | | | |
| | | | TIMER_IO10 | 3 | IO | 0 | | | | | | | | |
| | | | PRG0_IEP0_EDIO_OUTVALID | 4 | O | | | | | | | | | |
| | | | UART6_RXD | 5 | I | 1 | | | | | | | | |
| | | | ADC_EXT_TRIGGER0 | 6 | I | 0 | | | | | | | | |
| GPIO1_43 | 7 | IO | pad | | | | | | | | | | | |
| A13 | A8 | SPI0_D0 PADCONFIG: PADCONFIG133 0x000F4214 | SPI0_D0 | 0 | IO | 0 | Off / Off / Off | Off / Off / Off | 7 | 1.8V / 3.3V | VDDSHV0 | Yes | LVCMOS | PU/PD |
| | | | GPIO1_45 | 7 | IO | pad | | | | | | | | |
| A14 | C9 | SPI0_D1 PADCONFIG: PADCONFIG134 0x000F4218 | SPI0_D1 | 0 | IO | 0 | Off / Off / Off | Off / Off / Off | 7 | 1.8V / 3.3V | VDDSHV0 | Yes | LVCMOS | PU/PD |
| | | | GPIO1_46 | 7 | IO | pad | | | | | | | | |

Table 5-1. Pin Attributes (ALV, ANI, ALX Packages) (continued)

| ALV ANI BALL NUMBER [1] | ALX BALL NUMBER [1] | BALL NAME [2] PADCONFIG Register [15] PADCONFIG Address [16] | SIGNAL NAME [3] | MUX MODE [4] | TYPE [5] | DSIS [6] | BALL STATE DURING RESET RX/TX/PULL [7] | BALL STATE AFTER RESET RX/TX/PULL [8] | MUX MODE AFTER RESET [9] | IO OPERATING VOLTAGE [10] | POWER [11] | HYS [12] | BUFFER TYPE [14] | Pull UP/DOWN TYPE [13] |
|-------------------------------------|------------------------------|--|-------------------------|-----------------|-------------|-------------|---|--|--------------------------------------|---------------------------------|------------|-------------|---------------------|------------------------------|
| B14 | | SPI1_CS0 PADCONFIG: PADCONFIG135 0x000F421C | SPI1_CS0 | 0 | IO | 1 | Off / Off / Off | Off / Off / Off | 7 | 1.8V / 3.3V | VDDSHV0 | Yes | LVCMOS | PU/PD |
| | | | EHRPWM6_A | 3 | IO | 0 | | | | | | | | |
| | | | GPIO1_47 | 7 | IO | pad | | | | | | | | |
| D14 | | SPI1_CS1 PADCONFIG: PADCONFIG136 0x000F4220 | SPI1_CS1 | 0 | IO | 1 | Off / Off / Off | Off / Off / Off | 7 | 1.8V / 3.3V | VDDSHV0 | Yes | LVCMOS | PU/PD |
| | | | CPTS0_TS_SYNC | 1 | O | | | | | | | | | |
| | | | I2C2_SDA | 2 | IOD | 1 | | | | | | | | |
| | | | PRG1_IEP0_EDIO_OUTVALID | 4 | O | | | | | | | | | |
| | | | UART6_TXD | 5 | O | | | | | | | | | |
| | | | ADC_EXT_TRIGGER1 | 6 | I | 0 | | | | | | | | |
| | | | GPIO1_48 | 7 | IO | pad | | | | | | | | |
| TIMER_IO11 | 8 | IO | 0 | | | | | | | | | | | |
| B15 | | SPI1_D0 PADCONFIG: PADCONFIG138 0x000F4228 | SPI1_D0 | 0 | IO | 0 | Off / Off / Off | Off / Off / Off | 7 | 1.8V / 3.3V | VDDSHV0 | Yes | LVCMOS | PU/PD |
| | | | EHRPWM6_SYNCO | 3 | O | | | | | | | | | |
| | | | GPIO1_50 | 7 | IO | pad | | | | | | | | |
| A15 | | SPI1_D1 PADCONFIG: PADCONFIG139 0x000F422C | SPI1_D1 | 0 | IO | 0 | Off / Off / Off | Off / Off / Off | 7 | 1.8V / 3.3V | VDDSHV0 | Yes | LVCMOS | PU/PD |
| | | | EHRPWM6_B | 3 | IO | 0 | | | | | | | | |
| | | | GPIO1_51 | 7 | IO | pad | | | | | | | | |
| B11 | C6 | TCK PADCONFIG: MCU_PADCONFIG26 0x04084068 | TCK | 0 | I | | On / Off / Up | On / Off / Up | 0 | 1.8V / 3.3V | VDDSHV_MCU | Yes | LVCMOS | PU/PD |
| C11 | A3 | TDI PADCONFIG: MCU_PADCONFIG28 0x04084070 | TDI | 0 | I | | On / Off / Up | On / Off / Up | 0 | 1.8V / 3.3V | VDDSHV_MCU | Yes | LVCMOS | PU/PD |
| A12 | B5 | TDO PADCONFIG: MCU_PADCONFIG29 0x04084074 | TDO | 0 | OZ | | Off / Off / Up | Off / SS / Up | 0 | 1.8V / 3.3V | VDDSHV_MCU | Yes | LVCMOS | PU/PD |
| C12 | B4 | TMS PADCONFIG: MCU_PADCONFIG30 0x04084078 | TMS | 0 | I | | On / Off / Up | On / Off / Up | 0 | 1.8V / 3.3V | VDDSHV_MCU | Yes | LVCMOS | PU/PD |
| D11 | B6 | TRSTn PADCONFIG: MCU_PADCONFIG27 0x0408406C | TRSTn | 0 | I | | On / Off / Down | On / Off / Down | 0 | 1.8V / 3.3V | VDDSHV_MCU | Yes | LVCMOS | PU/PD |

Table 5-1. Pin Attributes (ALV, ANI, ALX Packages) (continued)

| ALV ANI BALL NUMBER [1] | ALX BALL NUMBER [1] | BALL NAME [2] PADCONFIG Register [15] PADCONFIG Address [16] | SIGNAL NAME [3] | MUX MODE [4] | TYPE [5] | DSIS [6] | BALL STATE DURING RESET RX/TX/PULL [7] | BALL STATE AFTER RESET RX/TX/PULL [8] | MUX MODE AFTER RESET [9] | IO OPERATING VOLTAGE [10] | POWER [11] | HYS [12] | BUFFER TYPE [14] | Pull UP/DOWN TYPE [13] |
|-------------------------|---------------------|--|------------------------|--------------|----------|----------|--|---------------------------------------|--------------------------|---------------------------|------------|----------|------------------|------------------------|
| B16 | B9 | UART0_CTSn PADCONFIG: PADCONFIG142 0x000F4238 | UART0_CTSn | 0 | I | 1 | Off / Off / Off | Off / Off / Off | 7 | 1.8V / 3.3V | VDDSHV0 | Yes | LVCMOS | PU/PD |
| | | | SPI0_CS2 | 1 | IO | 1 | | | | | | | | |
| | | | ADC_EXT_TRIGGER0 | 2 | I | 0 | | | | | | | | |
| | | | UART2_RXD | 3 | I | 1 | | | | | | | | |
| | | | TIMER_IO6 | 4 | IO | 0 | | | | | | | | |
| | | | SPI4_CLK | 6 | IO | 0 | | | | | | | | |
| | | | GPIO1_54 | 7 | IO | pad | | | | | | | | |
| | | | EQEP0_S | 8 | IO | 0 | | | | | | | | |
| CP_GEMAC_CPTS0_TS_SYNC | 9 | O | | | | | | | | | | | | |
| A16 | A9 | UART0_RTSn PADCONFIG: PADCONFIG143 0x000F423C | UART0_RTSn | 0 | O | | Off / Off / Off | Off / Off / Off | 7 | 1.8V / 3.3V | VDDSHV0 | Yes | LVCMOS | PU/PD |
| | | | SPI0_CS3 | 1 | IO | 1 | | | | | | | | |
| | | | UART2_TXD | 3 | O | | | | | | | | | |
| | | | TIMER_IO7 | 4 | IO | 0 | | | | | | | | |
| | | | SPI4_D0 | 6 | IO | 0 | | | | | | | | |
| | | | GPIO1_55 | 7 | IO | pad | | | | | | | | |
| | | | EQEP0_I | 8 | IO | 0 | | | | | | | | |
| D15 | B10 | UART0_RXD PADCONFIG: PADCONFIG140 0x000F4230 | UART0_RXD | 0 | I | 1 | Off / Off / Off | Off / Off / Off | 7 | 1.8V / 3.3V | VDDSHV0 | Yes | LVCMOS | PU/PD |
| | | | SPI2_D0 | 2 | IO | 0 | | | | | | | | |
| | | | GPIO1_52 | 7 | IO | pad | | | | | | | | |
| | | | EQEP0_A | 8 | I | 0 | | | | | | | | |
| C16 | B11 | UART0_TXD PADCONFIG: PADCONFIG141 0x000F4234 | UART0_TXD | 0 | O | | Off / Off / Off | Off / Off / Off | 7 | 1.8V / 3.3V | VDDSHV0 | Yes | LVCMOS | PU/PD |
| | | | SPI2_D1 | 2 | IO | 0 | | | | | | | | |
| | | | GPIO1_53 | 7 | IO | pad | | | | | | | | |
| | | | EQEP0_B | 8 | I | 0 | | | | | | | | |
| D16 | C11 | UART1_CTSn PADCONFIG: PADCONFIG146 0x000F4248 | UART1_CTSn | 0 | I | 1 | Off / Off / Off | Off / Off / Off | 7 | 1.8V / 3.3V | VDDSHV0 | Yes | LVCMOS | PU/PD |
| | | | SPI1_CS2 | 1 | IO | 1 | | | | | | | | |
| | | | ADC_EXT_TRIGGER1 | 2 | I | 0 | | | | | | | | |
| | | | PCIE0_CLKREQn | 3 | IO | 0 | | | | | | | | |
| | | | UART3_RXD | 4 | I | 1 | | | | | | | | |
| | | | CP_GEMAC_CPTS0_TS_SYNC | 5 | O | | | | | | | | | |
| | | | SPI4_D1 | 6 | IO | 0 | | | | | | | | |
| | | | GPIO1_58 | 7 | IO | pad | | | | | | | | |
| EQEP1_S | 8 | IO | 0 | | | | | | | | | | | |

Table 5-1. Pin Attributes (ALV, ANI, ALX Packages) (continued)

| ALV ANI BALL NUMBER [1] | ALX BALL NUMBER [1] | BALL NAME [2] PADCONFIG Register [15] PADCONFIG Address [16] | SIGNAL NAME [3] | MUX MODE [4] | TYPE [5] | DSIS [6] | BALL STATE DURING RESET RX/TX/PULL [7] | BALL STATE AFTER RESET RX/TX/PULL [8] | MUX MODE AFTER RESET [9] | IO OPERATING VOLTAGE [10] | POWER [11] | HYS [12] | BUFFER TYPE [14] | Pull UP/DOWN TYPE [13] |
|-------------------------|---------------------|--|--------------------------|--------------|----------|----------|--|---------------------------------------|--------------------------|---------------------------|---------------------------------|----------|------------------|------------------------|
| E16 | A11 | UART1_RTSn PADCONFIG: PADCONFIG147 0x000F424C | UART1_RTSn | 0 | O | | Off / Off / Off | Off / Off / Off | 7 | 1.8V / 3.3V | VDDSHV0 | Yes | LVCMOS | PU/PD |
| | | | SPI1_CS3 | 1 | IO | 1 | | | | | | | | |
| | | | UART3_TXD | 4 | O | | | | | | | | | |
| | | | CP_GEMAC_CPTS0_HW2TSPUSH | 5 | I | 0 | | | | | | | | |
| | | | SPI4_CS0 | 6 | IO | 1 | | | | | | | | |
| | | | GPIO1_59 | 7 | IO | pad | | | | | | | | |
| EQEP1_I | 8 | IO | 0 | | | | | | | | | | | |
| E15 | B12 | UART1_RXD PADCONFIG: PADCONFIG144 0x000F4240 | UART1_RXD | 0 | I | 1 | Off / Off / Off | Off / Off / Off | 7 | 1.8V / 3.3V | VDDSHV0 | Yes | LVCMOS | PU/PD |
| | | | SPI2_CS0 | 2 | IO | 1 | | | | | | | | |
| | | | CP_GEMAC_CPTS0_TS_COMP | 5 | O | | | | | | | | | |
| | | | GPIO1_56 | 7 | IO | pad | | | | | | | | |
| | | | EQEP1_A | 8 | I | 0 | | | | | | | | |
| E14 | A12 | UART1_TXD PADCONFIG: PADCONFIG145 0x000F4244 | UART1_TXD | 0 | O | | Off / Off / Off | Off / Off / Off | 7 | 1.8V / 3.3V | VDDSHV0 | Yes | LVCMOS | PU/PD |
| | | | SPI2_CLK | 2 | IO | 0 | | | | | | | | |
| | | | CP_GEMAC_CPTS0_HW1TSPUSH | 5 | I | 0 | | | | | | | | |
| | | | GPIO1_57 | 7 | IO | pad | | | | | | | | |
| | | | EQEP1_B | 8 | I | 0 | | | | | | | | |
| AA20 | AA17 | USB0_DM | USB0_DM | | IO | | | | | 1.8V / 3.3V | VDDA_3P3_USB0, VDDA_1P8_USB0 | | USB2PHY | |
| AA19 | AA16 | USB0_DP | USB0_DP | | IO | | | | | 1.8V / 3.3V | VDDA_3P3_USB0, VDDA_1P8_USB0 | | USB2PHY | |
| E19 | B19 | USB0_DRVVBUS PADCONFIG: PADCONFIG170 0x000F42A8 | USB0_DRVVBUS | 0 | O | | Off / Off / Down | Off / Off / Down | 7 | 1.8V / 3.3V | VDDSHV0 | Yes | LVCMOS | PU/PD |
| | | | GPIO1_79 | 7 | IO | pad | | | | | | | | |
| U16 | Y17 | USB0_ID | USB0_ID | | A | | | | | 1.8V / 3.3V | VDDA_3P3_USB0, VDDA_1P8_USB0 | | USB2PHY | |
| U17 | W17 | USB0_RCALIB | USB0_RCALIB | | A | | | | | 1.8V / 3.3V | VDDA_3P3_USB0, VDDA_1P8_USB0 | | USB2PHY | |
| T14 | V18 | USB0_VBUS | USB0_VBUS | | A | | | | | 1.8V / 3.3V | VDDA_3P3_USB0, VDDA_1P8_USB0 | | USB2PHY | |
| P12, P13 | | VDDA_0P85_SERDES0 | VDDA_0P85_SERDES0 | | PWR | | | | | | | | | |
| P11 | | VDDA_0P85_SERDES0_C | VDDA_0P85_SERDES0_C | | PWR | | | | | | | | | |
| T12 | V16 | VDDA_0P85_USB0 | VDDA_0P85_USB0 | | PWR | | | | | | | | | |
| R14 | | VDDA_1P8_SERDES0 | VDDA_1P8_SERDES0 | | PWR | | | | | | | | | |
| R15 | U15 | VDDA_1P8_USB0 | VDDA_1P8_USB0 | | PWR | | | | | | | | | |
| H15 | K15 | VDDA_3P3_SDIO | VDDA_3P3_SDIO | | PWR | | | | | | | | | |
| R13 | U16 | VDDA_3P3_USB0 | VDDA_3P3_USB0 | | PWR | | | | | | | | | |
| J13 | G17, H17 | VDDA_ADC | VDDA_ADC | | PWR | | | | | | | | | |

Table 5-1. Pin Attributes (ALV, ANI, ALX Packages) (continued)

| ALV ANI BALL NUMBER [1] | ALX BALL NUMBER [1] | BALL NAME [2] PADCONFIG Register [15] PADCONFIG Address [16] | SIGNAL NAME [3] | MUX MODE [4] | TYPE [5] | DSIS [6] | BALL STATE DURING RESET RX/TX/PULL [7] | BALL STATE AFTER RESET RX/TX/PULL [8] | MUX MODE AFTER RESET [9] | IO OPERATING VOLTAGE [10] | POWER [11] | HYS [12] | BUFFER TYPE [14] | Pull UP/DOWN TYPE [13] |
|---|---|--|-----------------|-----------------|-------------|-------------|---|--|--------------------------------------|---------------------------------|------------|-------------|---------------------|------------------------------|
| K12 | H14 | VDDA_MCU | VDDA_MCU | | PWR | | | | | | | | | |
| N12 | N12 | VDDA_PLL0 | VDDA_PLL0 | | PWR | | | | | | | | | |
| H9 | G9 | VDDA_PLL1 | VDDA_PLL1 | | PWR | | | | | | | | | |
| J11 | G12 | VDDA_PLL2 | VDDA_PLL2 | | PWR | | | | | | | | | |
| G11 | G11 | VDDA_TEMP0 | VDDA_TEMP0 | | PWR | | | | | | | | | |
| L11 | M11 | VDDA_TEMP1 | VDDA_TEMP1 | | PWR | | | | | | | | | |
| L10, M13 | G5, G6, J10, J12, P14, P8, R10 | VDDR_CORE | VDDR_CORE | | PWR | | | | | | | | | |
| F11, G12, G14 | C13, D13, E14 | VDDSHV0 | VDDSHV0 | | PWR | | | | | | | | | |
| M7, N6, P7 | L6, M6, P5, P6 | VDDSHV1 | VDDSHV1 | | PWR | | | | | | | | | |
| R10, R8, T9 | T11, T8, U11, U7, U8 | VDDSHV2 | VDDSHV2 | | PWR | | | | | | | | | |
| P14, P15 | R17, T17 | VDDSHV3 | VDDSHV3 | | PWR | | | | | | | | | |
| M14, M15 | N16, N17 | VDDSHV4 | VDDSHV4 | | PWR | | | | | | | | | |
| L14, L15 | L16, L17 | VDDSHV5 | VDDSHV5 | | PWR | | | | | | | | | |
| F9, G10, G8 | E7, E8, E9 | VDDSHV_MCU | VDDSHV_MCU | | PWR | | | | | | | | | |
| F7, G6, H7, J6, K7, L6 | | VDDS_DDR | VDDS_DDR | | PWR | | | | | | | | | |
| J8 | | VDDS_DDR_C | VDDS_DDR_C | | PWR | | | | | | | | | |
| K14 | | VDDS_MMC0 | VDDS_MMC0 | | PWR | | | | | | | | | |
| H13 | F18 | VDDS_OSC | VDDS_OSC | | PWR | | | | | | | | | |
| J10, J12, K11, K9, L12, L8, M11, M9, N10, N8, P9 | F11, G10, H15, H8, J9, K11, K14, L13, L9, M14, M8, N10, N9, R12, R13, R9 | VDD_CORE | VDD_CORE | | PWR | | | | | | | | | |
| H14 | | VDD_DLL_MMC0 | VDD_DLL_MMC0 | | PWR | | | | | | | | | |
| K13 | | VDD_MMC0 | VDD_MMC0 | | PWR | | | | | | | | | |
| K16 | | VMON_1P8_MCU | VMON_1P8_MCU | | A | | | | | | | | | |
| E12 | F14 | VMON_1P8_SOC | VMON_1P8_SOC | | A | | | | | | | | | |
| F13 | | VMON_3P3_MCU | VMON_3P3_MCU | | A | | | | | | | | | |
| F14 | E15 | VMON_3P3_SOC | VMON_3P3_SOC | | A | | | | | | | | | |
| K10 | G13 | VMON_VSYS | VMON_VSYS | | A | | | | | | | | | |

Table 5-1. Pin Attributes (ALV, ANI, ALX Packages) (continued)

| ALV ANI BALL NUMBER [1] | ALX BALL NUMBER [1] | BALL NAME [2] PADCONFIG Register [15] PADCONFIG Address [16] | SIGNAL NAME [3] | MUX MODE [4] | TYPE [5] | DSIS [6] | BALL STATE DURING RESET RX/TX/PULL [7] | BALL STATE AFTER RESET RX/TX/PULL [8] | MUX MODE AFTER RESET [9] | IO OPERATING VOLTAGE [10] | POWER [11] | HYS [12] | BUFFER TYPE [14] | Pull UP/DOWN TYPE [13] |
|--|--|--|-----------------|-----------------|-------------|-------------|---|--|--------------------------------------|---------------------------------|------------|-------------|---------------------|------------------------------|
| G15 | E16 | VPP | VPP | | PWR | | | | | | | | | |
| A1, A21, A5, A6, AA1, AA15, AA18, AA21, C10, C15, C3, D1, E11, E13, F10, F15, F8, G1, G16, G3, G7, G9, H11, H20, H21, H6, H8, J14, J7, J9, K6, K8, L1, L16, L3, L7, L9, M10, M12, M6, M8, N11, N13, N15, N7, N9, P1, P10, P18, P6, P8, R12, R7, R9, T10, T11, T15, T16, T8, U3, V17, W10, W18, Y14, Y17, Y19 | A1, A2, A20, A21, AA1, AA2, AA20, AA21, B1, B21, D10, D16, D17, E11, E13, E6, F17, F8, G16, H16, H6, H7, J11, J16, J5, J6, K16, K6, K7, K8, L10, L11, L12, M15, M16, M7, N11, N13, N6, P11, P15, P16, P7, R11, R6, T14, U6, Y1, Y21 | VSS | VSS | | GND | | | | | | | | | |

5.3 Signal Descriptions

Many signals are available on multiple pins, according to the software configuration of the pin multiplexing options.

The following list describes the column headers:

1. **SIGNAL NAME:** The name of the signal passing through the pin.

Note

Signal names and descriptions provided in each Signal Descriptions table, represent the pin multiplexed signal function implemented at the pin and selected via PADCONFIG registers. Some device subsystems provide an additional layer of multiplexing for signal functions that are not described in these tables. For more information on secondary multiplexed signal functions, see the respective peripheral chapter of the device TRM.

2. **SIGNAL TYPE:** Signal direction and type:
 - I = Input
 - O = Output
 - OD = Output, with open-drain output function
 - IO = Input, Output, or simultaneously Input and Output
 - IOD = Input, Output, or simultaneously Input and Output, with open-drain output function
 - IOZ = Input, Output, or simultaneously Input and Output, with three-state output function
 - OZ = Output with three-state output function
 - A = Analog
 - PWR = Power
 - GND = Ground
 - CAP = LDO Capacitor
3. **DESCRIPTION:** Description of the signal
4. **BALL:** Ball number associated with signal

For more information on the I/O cell configurations, see the *Pad Configuration Registers* section within the *Device Configuration* chapter of the device TRM.

5.3.1 AM243x_ALX Package - Unsupported Interfaces and Signals

Note

The following peripherals and signals are not supported by the ALX packaged devices. In some cases, the entire peripheral is not supported due to critical signals not being available on the ALX packaged devices.

Table 5-2. AM243x_ALX Package - Unsupported Peripheral Interfaces and Signals Table

| MAIN DOMAIN | MCU DOMAIN |
|---|--|
| PERIPHERAL INSTANCES ⁽¹⁾ | |
| <ul style="list-style-type: none"> • DDRSS0 • EPWM4 • EPWM6 • FSI1 TX • FSI4 RX • FSI5 RX • GPMC0 • I2C2 • MMC0 • SERDES0 • MCSPI1 | <ul style="list-style-type: none"> • MCU_I2C0 • MCU_I2C1 • MCU_MCSPI0 • MCU_MCSPI1 • MCU_UART1 |
| GPIO SIGNALS | |
| <ul style="list-style-type: none"> • GPIO0_[7:10] • GPIO0_[13:14] • GPIO0_[31:35] • GPIO0_[37:44] • GPIO1_42 • GPIO1_[47:51] • GPIO1_68 • GPIO1_70 | <ul style="list-style-type: none"> • MCU_GPIO[4:21] |
| MISCELLANEOUS SIGNALS | |
| <ul style="list-style-type: none"> • CP_GEMAC_CPTS0_RFT_CLK • CPTS0_RFT_CLK • SYNC0_OUT • ECAP0_IN_APWM_OUT • TRC_DATA[14:23] • EHRPWM_TZn_IN[5:3] • EHRPWM5_B • SPI0_CS0 • SPI4_CS3 • OSPI0_ECC_FAIL • OSPI0_CS_n[2:3] • OSPI0_D[4:7] • OSPI0_RESET_OUT[0:1] • PRG1_IEP0_EDIO_OUTVALID • EXTINT_n | <ul style="list-style-type: none"> • MCU_EXT_REFCLK0 • MCU_SYSCLKOUT0 • VMON_1P8_MCU • MCU_TIMER_IO[2:3] |

(1) The entire peripheral instance is not supported for the ALX packaged devices.

5.3.2 ADC

MAIN Domain Instances

Table 5-3. ADC0 Signal Descriptions

| SIGNAL NAME [1] | SIGNAL TYPE [2] | DESCRIPTION [3] | ALV/ANI PIN [4] | ALX PIN [4] |
|----------------------------------|-----------------|--|-----------------|-------------|
| ADC0_REFN ^{(5) (7)} | A | ADC0 Negative Reference | J16 | |
| ADC0_REFP ^{(5) (6)} | A | ADC0 Positive Reference | J15 | |
| ADC0_AIN0 ^{(2) (3) (4)} | A | ADC Analog Input 0 / GPIO1_80 (Input Only) | G20 | H21 |
| ADC0_AIN1 ^{(2) (3) (4)} | A | ADC Analog Input 1 / GPIO1_81 (Input Only) | F20 | F19 |
| ADC0_AIN2 ^{(2) (3) (4)} | A | ADC Analog Input 2 / GPIO1_82 (Input Only) | E21 | F21 |
| ADC0_AIN3 ^{(2) (3) (4)} | A | ADC Analog Input 3 / GPIO1_83 (Input Only) | D20 | F20 |
| ADC0_AIN4 ^{(2) (3) (4)} | A | ADC Analog Input 4 / GPIO1_84 (Input Only) | G21 | H20 |
| ADC0_AIN5 ^{(2) (3) (4)} | A | ADC Analog Input 5 / GPIO1_85 (Input Only) | F21 | E21 |
| ADC0_AIN6 ^{(2) (3) (4)} | A | ADC Analog Input 6 / GPIO1_86 (Input Only) | F19 | G20 |
| ADC0_AIN7 ^{(2) (3) (4)} | A | ADC Analog Input 7 / GPIO1_87 (Input Only) | E20 | E20 |
| ADC_EXT_TRIGGER0 ⁽¹⁾ | I | ADC Trigger Input | B16, C13 | B7, B9 |
| ADC_EXT_TRIGGER1 ⁽¹⁾ | I | ADC Trigger Input | D14, D16 | C11 |

- (1) This ADC Trigger input signal has a debounce function. For more information on I/O Debounce configuration, see the TRM *Device Configuration* chapter.
- (2) The General Purpose Input signal associated with this ADC0_AIN input has a debounce function when ADC0 is configured to operate in GPI mode. For more information on configuring ADC0 to operate in GPI mode, see the TRM *Analog-to-Digital Converter (ADC)* section in the *Peripherals* chapter. For more information on I/O Debounce configuration, see the TRM *Device Configuration* chapter.
- (3) The ADC0_AIN[7:0] inputs only have hysteresis when ADC0 is configured to operate in GPI mode.
- (4) Any unused ADC0_AIN inputs must be pulled to VSS through a resistor or connected directly to VSS when VDDA_ADC is connected to a power source.
- (5) The ADC0_REFP and ADC0_REFN reference inputs are analog inputs which must be treated like high transient power supply rails, where ADC0_REFN is expected to be connected directly to the PCB ground plane along with all other VSS pins, and ADC0_REFP is connected to a power source capable of providing at least 4mA of current. ADC0_REFP may be connected to the same power source as VDDA_ADC if the voltage tolerance of the supply provides an acceptable accuracy for the ADC reference. A high frequency decoupling capacitor must be connected directly between ADC0_REFP and ADC0_REFN. The high frequency decoupling capacitor should be placed in the ball array on the back side of the PCB and connected directly to the ADC0_REFP and ADC0_REFN pins with vias. ADC0_REFP may be connected to VSS if ADC0 is not used and VDDA_ADC0 has been connected to VSS. The high frequency decoupling capacitor described above will not be required if ADC0 is not used and ADC0_REFP is connected to VSS. See the *Pin Connectivity Requirements* section for more information on ADC0 connectivity.
- (6) ADC0_REFP is connected to VDDA_ADC0 inside the ALX packaged devices.
- (7) ADC0_REFN is connected to VSS inside the ALX packaged devices.

5.3.3 CPSW

MAIN Domain Instances

Table 5-4. CPSW3G0 RGMII1 Signal Descriptions

| SIGNAL NAME [1] | SIGNAL TYPE [2] | DESCRIPTION [3] | ALV/ANI PIN [4] | ALX PIN [4] |
|-----------------|-----------------|------------------------|-----------------|-------------|
| RGMII1_RXC | I | RGMII Receive Clock | AA5, W13 | U1, Y13 |
| RGMII1_RX_CTL | I | RGMII Receive Control | V13, W6 | U14, Y3 |
| RGMII1_TXC | IO | RGMII Transmit Clock | U14 | W13 |
| RGMII1_TX_CTL | O | RGMII Transmit Control | U15 | W16 |
| RGMII1_RD0 | I | RGMII Receive Data 0 | AA13, W5 | AA11, T5 |
| RGMII1_RD1 | I | RGMII Receive Data 1 | U12, Y5 | R2, W11 |
| RGMII1_RD2 | I | RGMII Receive Data 2 | V6, Y13 | U2, Y15 |
| RGMII1_RD3 | I | RGMII Receive Data 3 | V12, V5 | AA13, T1 |
| RGMII1_TD0 | O | RGMII Transmit Data 0 | V15 | Y14 |
| RGMII1_TD1 | O | RGMII Transmit Data 1 | V14 | Y16 |
| RGMII1_TD2 | O | RGMII Transmit Data 2 | W14 | U13 |
| RGMII1_TD3 | O | RGMII Transmit Data 3 | AA14 | AA14 |

Table 5-5. CPSW3G0 RGMII2 Signal Descriptions

| SIGNAL NAME [1] | SIGNAL TYPE [2] | DESCRIPTION [3] | ALV/ANI PIN [4] | ALX PIN [4] |
|-----------------|-----------------|------------------------|-----------------|-------------|
| RGMII2_RXC | I | RGMII Receive Clock | U11 | V10 |
| RGMII2_RX_CTL | I | RGMII Receive Control | W12 | Y12 |
| RGMII2_TXC | IO | RGMII Transmit Clock | Y10 | Y8 |
| RGMII2_TX_CTL | O | RGMII Transmit Control | Y11 | V9 |
| RGMII2_RD0 | I | RGMII Receive Data 0 | W11 | AA10 |
| RGMII2_RD1 | I | RGMII Receive Data 1 | V11 | Y10 |
| RGMII2_RD2 | I | RGMII Receive Data 2 | AA12 | Y11 |
| RGMII2_RD3 | I | RGMII Receive Data 3 | Y12 | V12 |
| RGMII2_TD0 | O | RGMII Transmit Data 0 | AA10 | Y6 |
| RGMII2_TD1 | O | RGMII Transmit Data 1 | V10 | AA8 |
| RGMII2_TD2 | O | RGMII Transmit Data 2 | U10 | Y9 |
| RGMII2_TD3 | O | RGMII Transmit Data 3 | AA11 | W9 |

Table 5-6. CPSW3G0 RMII1 and RMII2 Signal Descriptions

| SIGNAL NAME [1] | SIGNAL TYPE [2] | DESCRIPTION [3] | ALV/ANI PIN [4] | ALX PIN [4] |
|-----------------------------|-----------------|---------------------------------|-----------------|-------------|
| RMII1_CRS_DV | I | RMII Carrier Sense / Data Valid | R2, V12 | AA13, F3 |
| RMII1_RX_ER | I | RMII Receive Data Error | U15, W6 | W16, Y3 |
| RMII1_TX_EN | O | RMII Transmit Enable | P5, Y13 | D1, Y15 |
| RMII2_CRS_DV | I | RMII Carrier Sense / Data Valid | U10 | Y9 |
| RMII2_RX_ER | I | RMII Receive Data Error | W12 | Y12 |
| RMII2_TX_EN | O | RMII Transmit Enable | Y11 | V9 |
| RMII1_RXD0 | I | RMII Receive Data 0 | V15, W5 | T5, Y14 |
| RMII1_RXD1 | I | RMII Receive Data 1 | V14, Y5 | R2, Y16 |
| RMII1_TXD0 | O | RMII Transmit Data 0 | V6, W14 | U13, U2 |
| RMII1_TXD1 | O | RMII Transmit Data 1 | AA14, V5 | AA14, T1 |
| RMII2_RXD0 | I | RMII Receive Data 0 | W11 | AA10 |
| RMII2_RXD1 | I | RMII Receive Data 1 | V11 | Y10 |
| RMII2_TXD0 | O | RMII Transmit Data 0 | AA10 | Y6 |
| RMII2_TXD1 | O | RMII Transmit Data 1 | V10 | AA8 |
| RMII_REF_CLK ⁽¹⁾ | I | RMII Reference Clock | AA5, U14 | U1, W13 |

(1) RMII_REF_CLK is common to both RMII1 and RMII2.

Table 5-7. MDIO0 Signal Descriptions

| SIGNAL NAME [1] | SIGNAL TYPE [2] | DESCRIPTION [3] | ALV/ANI PIN [4] | ALX PIN [4] |
|-----------------|-----------------|-----------------|-----------------|-------------|
| MDIO0_MDC | O | MDIO Clock | R2, Y6 | F3, W1 |
| MDIO0_MDIO | IO | MDIO Data | AA6, P5 | D1, V2 |

5.3.3.1 CPSW3G IOSETs

Table 5-8 defines valid pin combinations of each CPSW3G MDIO0 IOSET.

Table 5-8. CPSW3G MDIO0 IOSETs

| SIGNALS | IOSET1 | | IOSET2 | |
|------------|-----------------|---------|-----------------|---------|
| | BALL NAME | MUXMODE | BALL NAME | MUXMODE |
| MDIO0_MDIO | PRG0_PRU1_GPO18 | 4 | PRG1_MDIO0_MDIO | 4 |
| MDIO0_MDC | PRG0_PRU1_GPO19 | 4 | PRG1_MDIO0_MDC | 4 |

Table 5-9 defines valid pin combinations of each CPSW3G RMII1 and RMII2 IOSET.

Table 5-9. CPSW3G RMII1 and RMII2 IOSETs

| SIGNALS | IOSET1 | | IOSET2 | |
|-----------------------------|-----------------|---------|-----------------|---------|
| | BALL NAME | MUXMODE | BALL NAME | MUXMODE |
| RMII_REF_CLK ⁽¹⁾ | PRG1_PRU0_GPO10 | 5 | PRG0_PRU0_GPO10 | 5 |
| RMII1_CRS_DV | PRG1_PRU1_GPO19 | 5 | PRG0_PRU1_GPO19 | 5 |
| RMII1_RX_ER | PRG1_PRU0_GPO9 | 5 | PRG0_PRU0_GPO9 | 5 |
| RMII1_RXD0 | PRG1_PRU1_GPO7 | 5 | PRG0_PRU1_GPO7 | 5 |
| RMII1_RXD1 | PRG1_PRU1_GPO9 | 5 | PRG0_PRU1_GPO9 | 5 |
| RMII1_TXD0 | PRG1_PRU1_GPO10 | 5 | PRG0_PRU1_GPO10 | 5 |
| RMII1_TXD1 | PRG1_PRU1_GPO17 | 5 | PRG0_PRU1_GPO17 | 5 |
| RMII1_TX_EN | PRG1_PRU1_GPO18 | 5 | PRG0_PRU1_GPO18 | 5 |
| RMII2_CRS_DV | PRG1_PRU1_GPO13 | 5 | PRG1_PRU1_GPO13 | 5 |
| RMII2_RX_ER | PRG1_PRU1_GPO4 | 5 | PRG1_PRU1_GPO4 | 5 |
| RMII2_RXD0 | PRG1_PRU1_GPO0 | 5 | PRG1_PRU1_GPO0 | 5 |
| RMII2_RXD1 | PRG1_PRU1_GPO1 | 5 | PRG1_PRU1_GPO1 | 5 |
| RMII2_TXD0 | PRG1_PRU1_GPO11 | 5 | PRG1_PRU1_GPO11 | 5 |
| RMII2_TXD1 | PRG1_PRU1_GPO12 | 5 | PRG1_PRU1_GPO12 | 5 |
| RMII2_TX_EN | PRG1_PRU1_GPO15 | 5 | PRG1_PRU1_GPO15 | 5 |

(1) RMII_REF_CLK is common to both RMII1 and RMII2. For proper operation, all pin multiplexed signal assignments must use the same IOSET.

Table 5-10 defines valid pin combinations of each CPSW3G RGMII1 IOSET.

Table 5-10. CPSW3G RGMII1 IOSETs

| SIGNALS | IOSET1 | | IOSET2 | |
|---------------|-----------------|---------|-----------------|---------|
| | BALL NAME | MUXMODE | BALL NAME | MUXMODE |
| RGMII1_TX_CTL | PRG1_PRU0_GPO9 | 4 | PRG1_PRU0_GPO9 | 4 |
| RGMII1_TXC | PRG1_PRU0_GPO10 | 4 | PRG1_PRU0_GPO10 | 4 |
| RGMII1_TD0 | PRG1_PRU1_GPO7 | 4 | PRG1_PRU1_GPO7 | 4 |
| RGMII1_TD1 | PRG1_PRU1_GPO9 | 4 | PRG1_PRU1_GPO9 | 4 |
| RGMII1_TD2 | PRG1_PRU1_GPO10 | 4 | PRG1_PRU1_GPO10 | 4 |
| RGMII1_TD3 | PRG1_PRU1_GPO17 | 4 | PRG1_PRU1_GPO17 | 4 |
| RGMII1_RX_CTL | PRG0_PRU0_GPO9 | 4 | PRG1_PRU0_GPO5 | 4 |
| RGMII1_RXC | PRG0_PRU0_GPO10 | 4 | PRG1_PRU0_GPO8 | 4 |
| RGMII1_RD0 | PRG0_PRU1_GPO7 | 4 | PRG1_PRU1_GPO5 | 4 |
| RGMII1_RD1 | PRG0_PRU1_GPO9 | 4 | PRG1_PRU1_GPO8 | 4 |
| RGMII1_RD2 | PRG0_PRU1_GPO10 | 4 | PRG1_PRU1_GPO18 | 4 |
| RGMII1_RD3 | PRG0_PRU1_GPO17 | 4 | PRG1_PRU1_GPO19 | 4 |

5.3.4 CPTS

MAIN Domain Instances

Table 5-11. CP GEMAC CPTS0 Signal Descriptions

| SIGNAL NAME [1] | SIGNAL TYPE [2] | DESCRIPTION [3] | ALV/ANI PIN [4] | ALX PIN [4] |
|---------------------------------------|-----------------|--|-------------------|------------------|
| CP_GEMAC_CPTS0_RFT_CLK ⁽¹⁾ | I | CPTS Reference Clock Input to CPSW3G0 CPTS | D18 | |
| CP_GEMAC_CPTS0_TS_COMP | O | CPTS Time Stamp Counter Compare Output from CPSW3G0 CPTS | E15, K18, W1 | B12, G2, K18 |
| CP_GEMAC_CPTS0_TS_SYNC | O | CPTS Time Stamp Counter Bit Output from CPSW3G0 CPTS | B16, D16, K19, U1 | B9, C11, E1, K20 |
| CP_GEMAC_CPTS0_HW1TSPUSH | I | CPTS Hardware Time Stamp Push Input to CPSW3G0 CPTS | E14, L21, V1 | A12, J19, K4 |
| CP_GEMAC_CPTS0_HW2TSPUSH | I | CPTS Hardware Time Stamp Push Input to CPSW3G0 CPTS | E16, K21, T1 | A11, E2, J18 |

- (1) The CP_GEMAC_CPTS0_RFT_CLK signal is not supported by the ALX packaged device. See [AM243x_ALX Package - Unsupported Interfaces and Signals](#) for additional details.

Table 5-12. CPTS0 Signal Descriptions

| SIGNAL NAME [1] | SIGNAL TYPE [2] | DESCRIPTION [3] | ALV/ANI PIN [4] | ALX PIN [4] |
|------------------------------|-----------------|--|-----------------|--------------|
| CPTS0_RFT_CLK ⁽²⁾ | I | CPTS Reference Clock Input | D18 | |
| CPTS0_TS_COMP | O | CPTS Time Stamp Counter Compare Output | C13, W1, W7 | B7, G2, U3 |
| CPTS0_TS_SYNC | O | CPTS Time Stamp Counter Bit Output | D14, U1, U7 | E1, T2 |
| CPTS0_HW1TSPUSH | I | CPTS Hardware Time Stamp Push Input to Time Sync Router | C18, V1, V7 | A17, K4, Y4 |
| CPTS0_HW2TSPUSH | I | CPTS Hardware Time Stamp Push Input to Time Sync Router | B19, T1, U13 | B18, E2, V13 |
| SYNC0_OUT ⁽¹⁾ | O | CPTS Time Stamp Generator Bit 0 Output from Time Sync Router | D18 | |
| SYNC1_OUT | O | CPTS Time Stamp Generator Bit 1 Output from Time Sync Router | A19 | A18 |
| SYNC2_OUT | O | CPTS Time Stamp Generator Bit 2 Output from Time Sync Router | A17 | B13 |
| SYNC3_OUT | O | CPTS Time Stamp Generator Bit 3 Output from Time Sync Router | B17 | A14 |

- (1) The SYNC0_OUT signal is not supported by the ALX packaged device. See [AM243x_ALX Package - Unsupported Interfaces and Signals](#) for additional details.
- (2) The CPTS0_RFT_CLK signal is not supported by the ALX packaged device. See [AM243x_ALX Package - Unsupported Interfaces and Signals](#) for additional details.

5.3.5 DDRSS

MAIN Domain Instances

Table 5-13. DDRSS0 Signal Descriptions

| SIGNAL NAME [1] ⁽²⁾ | SIGNAL TYPE [2] | DESCRIPTION [3] | ALV/ANI PIN [4] | ALX PIN [4] |
|--------------------------------|-----------------|----------------------------------|-----------------|-------------|
| DDR0_ACT_n | O | DDRSS Activation Command | H2 | |
| DDR0_ALERT_n | IO | DDRSS Alert | H1 | |
| DDR0_CAS_n | O | DDRSS Column Address Strobe | J5 | |
| DDR0_PAR | O | DDRSS Command and Address Parity | K5 | |
| DDR0_RAS_n | O | DDRSS Row Address Strobe | F6 | |
| DDR0_WE_n | O | DDRSS Write Enable | H4 | |
| DDR0_A0 | O | DDRSS Address Bus | D2 | |
| DDR0_A1 | O | DDRSS Address Bus | C5 | |
| DDR0_A2 | O | DDRSS Address Bus | E2 | |
| DDR0_A3 | O | DDRSS Address Bus | D4 | |
| DDR0_A4 | O | DDRSS Address Bus | D3 | |
| DDR0_A5 | O | DDRSS Address Bus | F2 | |
| DDR0_A6 | O | DDRSS Address Bus | J2 | |
| DDR0_A7 | O | DDRSS Address Bus | L5 | |

Table 5-13. DDRSS0 Signal Descriptions (continued)

| SIGNAL NAME [1] (2) | SIGNAL TYPE [2] | DESCRIPTION [3] | ALV/ANI PIN [4] | ALX PIN [4] |
|---------------------|-----------------|--|-----------------|-------------|
| DDR0_A8 | O | DDRSS Address Bus | J3 | |
| DDR0_A9 | O | DDRSS Address Bus | J4 | |
| DDR0_A10 | O | DDRSS Address Bus | K3 | |
| DDR0_A11 | O | DDRSS Address Bus | J1 | |
| DDR0_A12 | O | DDRSS Address Bus | M5 | |
| DDR0_A13 | O | DDRSS Address Bus | K4 | |
| DDR0_BA0 | O | DDRSS Bank Address | G4 | |
| DDR0_BA1 | O | DDRSS Bank Address | G5 | |
| DDR0_BG0 | O | DDRSS Bank Group | G2 | |
| DDR0_BG1 | O | DDRSS Bank Group | H3 | |
| DDR0_CAL0 (1) | A | IO Pad Calibration Resistor | H5 | |
| DDR0_CK0 | O | DDRSS Clock | F1 | |
| DDR0_CK0_n | O | DDRSS Negative Clock | E1 | |
| DDR0_CKE0 | O | DDRSS Clock Enable | F4 | |
| DDR0_CKE1 | O | DDRSS Clock Enable | F3 | |
| DDR0_CS0_n | O | DDRSS Chip Select 0 | E3 | |
| DDR0_CS1_n | O | DDRSS Chip Select 1 | E4 | |
| DDR0_DM0 | IO | DDRSS Data Mask | B2 | |
| DDR0_DM1 | IO | DDRSS Data Mask | M2 | |
| DDR0_DQ0 | IO | DDRSS Data | A3 | |
| DDR0_DQ1 | IO | DDRSS Data | A2 | |
| DDR0_DQ2 | IO | DDRSS Data | B5 | |
| DDR0_DQ3 | IO | DDRSS Data | A4 | |
| DDR0_DQ4 | IO | DDRSS Data | B3 | |
| DDR0_DQ5 | IO | DDRSS Data | C4 | |
| DDR0_DQ6 | IO | DDRSS Data | C2 | |
| DDR0_DQ7 | IO | DDRSS Data | B4 | |
| DDR0_DQ8 | IO | DDRSS Data | N5 | |
| DDR0_DQ9 | IO | DDRSS Data | L4 | |
| DDR0_DQ10 | IO | DDRSS Data | L2 | |
| DDR0_DQ11 | IO | DDRSS Data | M3 | |
| DDR0_DQ12 | IO | DDRSS Data | N4 | |
| DDR0_DQ13 | IO | DDRSS Data | N3 | |
| DDR0_DQ14 | IO | DDRSS Data | M4 | |
| DDR0_DQ15 | IO | DDRSS Data | N2 | |
| DDR0_DQS0 | IO | DDRSS Data Strobe 0 | C1 | |
| DDR0_DQS0_n | IO | DDRSS Complimentary Data Strobe 0 | B1 | |
| DDR0_DQS1 | IO | DDRSS Data Strobe 1 | N1 | |
| DDR0_DQS1_n | IO | DDRSS Complimentary Data Strobe 1 | M1 | |
| DDR0_ODT0 | O | DDRSS On-Die Termination for Chip Select 0 | E5 | |
| DDR0_ODT1 | O | DDRSS On-Die Termination for Chip Select 1 | F5 | |
| DDR0_RESET0_n | O | DDRSS Reset | D5 | |

(1) An external 240Ω ±1% resistor must be connected between this pin and VSS. The maximum power dissipation for the resistor is 5.2mW. No external voltage should be applied to this pin.

(2) The DDRSS0 interface is not supported by the ALX packaged devices. See [AM243x_ALX Package - Unsupported Interfaces and Signals](#) for additional details.

5.3.6 ECAP

MAIN Domain Instances

Table 5-14. ECAP0 Signal Descriptions

| SIGNAL NAME [1] | SIGNAL TYPE [2] | DESCRIPTION [3] | ALV/ANI PIN [4] | ALX PIN [4] |
|----------------------------------|-----------------|--|-----------------|-------------|
| ECAP0_IN_APWM_OUT ⁽¹⁾ | IO | Enhanced Capture (ECAP) Input or Auxiliary PWM (APWM) Output | D18 | |

(1) The ECAP0_IN_APWM_OUT signal is not supported by the ALX packaged device. See [AM243x_ALX Package - Unsupported Interfaces and Signals](#) for additional details.

Table 5-15. ECAP1 Signal Descriptions

| SIGNAL NAME [1] | SIGNAL TYPE [2] | DESCRIPTION [3] | ALV/ANI PIN [4] | ALX PIN [4] |
|-------------------|-----------------|--|-----------------|-------------|
| ECAP1_IN_APWM_OUT | IO | Enhanced Capture (ECAP) Input or Auxiliary PWM (APWM) Output | C17 | B14 |

Table 5-16. ECAP2 Signal Descriptions

| SIGNAL NAME [1] | SIGNAL TYPE [2] | DESCRIPTION [3] | ALV/ANI PIN [4] | ALX PIN [4] |
|-------------------|-----------------|--|-----------------|-------------|
| ECAP2_IN_APWM_OUT | IO | Enhanced Capture (ECAP) Input or Auxiliary PWM (APWM) Output | D17 | A15 |

5.3.7 Emulation and Debug

MAIN Domain Instances

Table 5-17. Trace Signal Descriptions

| SIGNAL NAME [1] | SIGNAL TYPE [2] | DESCRIPTION [3] | ALV/ANI PIN [4] | ALX PIN [4] |
|---------------------------|-----------------|-----------------|-----------------|-------------|
| TRC_CLK | O | Trace Clock | T20 | R21 |
| TRC_CTL | O | Trace Control | U21 | R20 |
| TRC_DATA0 | O | Trace Data 0 | T18 | T19 |
| TRC_DATA1 | O | Trace Data 1 | U20 | V21 |
| TRC_DATA2 | O | Trace Data 2 | U18 | U21 |
| TRC_DATA3 | O | Trace Data 3 | U19 | T20 |
| TRC_DATA4 | O | Trace Data 4 | V20 | T18 |
| TRC_DATA5 | O | Trace Data 5 | V21 | U19 |
| TRC_DATA6 | O | Trace Data 6 | V19 | U18 |
| TRC_DATA7 | O | Trace Data 7 | T17 | U20 |
| TRC_DATA8 | O | Trace Data 8 | R16 | V20 |
| TRC_DATA9 | O | Trace Data 9 | W20 | W20 |
| TRC_DATA10 | O | Trace Data 10 | W21 | Y20 |
| TRC_DATA11 | O | Trace Data 11 | V18 | Y19 |
| TRC_DATA12 | O | Trace Data 12 | Y21 | Y18 |
| TRC_DATA13 | O | Trace Data 13 | Y20 | AA19 |
| TRC_DATA14 ⁽¹⁾ | O | Trace Data 14 | R17 | |
| TRC_DATA15 ⁽¹⁾ | O | Trace Data 15 | P16 | |
| TRC_DATA16 ⁽¹⁾ | O | Trace Data 16 | R18 | |
| TRC_DATA17 ⁽¹⁾ | O | Trace Data 17 | T21 | |
| TRC_DATA18 ⁽¹⁾ | O | Trace Data 18 | P17 | |
| TRC_DATA19 ⁽¹⁾ | O | Trace Data 19 | T19 | P21 |
| TRC_DATA20 ⁽¹⁾ | O | Trace Data 20 | W19 | |
| TRC_DATA21 ⁽¹⁾ | O | Trace Data 21 | Y18 | |
| TRC_DATA22 ⁽¹⁾ | O | Trace Data 22 | N16 | |

Table 5-17. Trace Signal Descriptions (continued)

| SIGNAL NAME [1] | SIGNAL TYPE [2] | DESCRIPTION [3] | ALV/ANI PIN [4] | ALX PIN [4] |
|---------------------------|-----------------|-----------------|-----------------|-------------|
| TRC_DATA23 ⁽¹⁾ | O | Trace Data 23 | R19 | |

- (1) This TRC_DATA signal is not supported by the ALX packaged device. See [AM243x_ALX Package - Unsupported Interfaces and Signals](#) for additional details.

MCU Domain Instances

Table 5-18. JTAG Signal Descriptions

| SIGNAL NAME [1] | SIGNAL TYPE [2] | DESCRIPTION [3] | ALV/ANI PIN [4] | ALX PIN [4] |
|-----------------|-----------------|-----------------------------|-----------------|-------------|
| EMU0 | IO | Emulation Control 0 | D10 | C5 |
| EMU1 | IO | Emulation Control 1 | E10 | B3 |
| TCK | I | JTAG Test Clock Input | B11 | C6 |
| TDI | I | JTAG Test Data Input | C11 | A3 |
| TDO | OZ | JTAG Test Data Output | A12 | B5 |
| TMS | I | JTAG Test Mode Select Input | C12 | B4 |
| TRSTn | I | JTAG Reset | D11 | B6 |

5.3.8 EPWM

MAIN Domain Instances

Table 5-19. EPWM Signal Descriptions

| SIGNAL NAME [1] | SIGNAL TYPE [2] | DESCRIPTION [3] | ALV/ANI PIN [4] | ALX PIN [4] |
|-------------------------------|-----------------|-------------------------------------|-----------------|-------------|
| EHRPWM_SOC_A | O | EPWM Start of Conversion A | C17 | B14 |
| EHRPWM_SOC_B | O | EPWM Start of Conversion B | D17 | A15 |
| EHRPWM_TZn_IN0 | I | EPWM Trip Zone Input 0 (active low) | T18 | T19 |
| EHRPWM_TZn_IN1 | I | EPWM Trip Zone Input 1 (active low) | V21 | U19 |
| EHRPWM_TZn_IN2 | I | EPWM Trip Zone Input 2 (active low) | R16, R20 | V20 |
| EHRPWM_TZn_IN3 ⁽¹⁾ | I | EPWM Trip Zone Input 3 (active low) | P16 | |
| EHRPWM_TZn_IN4 ⁽²⁾ | I | EPWM Trip Zone Input 4 (active low) | P17, P19 | |
| EHRPWM_TZn_IN5 ⁽³⁾ | I | EPWM Trip Zone Input 5 (active low) | R21, Y18 | |

- (1) The EHRPWM_TZn_IN3 signal is not supported by the ALX packaged device. See [AM243x_ALX Package - Unsupported Interfaces and Signals](#) for additional details.
- (2) The EHRPWM_TZn_IN4 signal is not supported by the ALX packaged device. See [AM243x_ALX Package - Unsupported Interfaces and Signals](#) for additional details.
- (3) The EHRPWM_TZn_IN5 signal is not supported by the ALX packaged device. See [AM243x_ALX Package - Unsupported Interfaces and Signals](#) for additional details.

Table 5-20. EPWM0 Signal Descriptions

| SIGNAL NAME [1] | SIGNAL TYPE [2] | DESCRIPTION [3] | ALV/ANI PIN [4] | ALX PIN [4] |
|-----------------|-----------------|---|-----------------|-------------|
| EHRPWM0_A | IO | EPWM Output A | U20 | V21 |
| EHRPWM0_B | IO | EPWM Output B | U18 | U21 |
| EHRPWM0_SYNCI | I | Sync Input to EPWM module from an external pin | T20 | R21 |
| EHRPWM0_SYNCO | O | Sync Output from EPWM module to an external pin | U21 | R20 |

Table 5-21. EPWM1 Signal Descriptions

| SIGNAL NAME [1] | SIGNAL TYPE [2] | DESCRIPTION [3] | ALV/ANI PIN [4] | ALX PIN [4] |
|-----------------|-----------------|-----------------|-----------------|-------------|
| EHRPWM1_A | IO | EPWM Output A | U19 | T20 |
| EHRPWM1_B | IO | EPWM Output B | V20 | T18 |

Table 5-22. EPWM2 Signal Descriptions

| SIGNAL NAME [1] | SIGNAL TYPE [2] | DESCRIPTION [3] | ALV/ANI PIN [4] | ALX PIN [4] |
|-----------------|-----------------|-----------------|-----------------|-------------|
| EHRPWM2_A | IO | EPWM Output A | V19 | U18 |
| EHRPWM2_B | IO | EPWM Output B | T17 | U20 |

Table 5-23. EPWM3 Signal Descriptions

| SIGNAL NAME [1] | SIGNAL TYPE [2] | DESCRIPTION [3] | ALV/ANI PIN [4] | ALX PIN [4] |
|------------------------------|-----------------|---|-----------------|-------------|
| EHRPWM3_A | IO | EPWM Output A | V18 | Y19 |
| EHRPWM3_B | IO | EPWM Output B | Y21 | Y18 |
| EHRPWM3_SYNCI | I | Sync Input to EPWM module from an external pin | Y20 | AA19 |
| EHRPWM3_SYNCO ⁽¹⁾ | O | Sync Output from EPWM module to an external pin | R17 | |

- (1) The EHRPWM3_SYNCO signal is not supported by the ALX packaged device. See [AM243x_ALX Package - Unsupported Interfaces and Signals](#) for additional details.

Table 5-24. EPWM4 Signal Descriptions

| SIGNAL NAME [1] ⁽¹⁾ | SIGNAL TYPE [2] | DESCRIPTION [3] | ALV/ANI PIN [4] | ALX PIN [4] |
|--------------------------------|-----------------|-----------------|-----------------|-------------|
| EHRPWM4_A | IO | EPWM Output A | R18 | |
| EHRPWM4_B | IO | EPWM Output B | T21 | |

- (1) The EPWM4 interface is not supported by the ALX packaged devices. See [AM243x_ALX Package - Unsupported Interfaces and Signals](#) for additional details.

Table 5-25. EPWM5 Signal Descriptions

| SIGNAL NAME [1] | SIGNAL TYPE [2] | DESCRIPTION [3] | ALV/ANI PIN [4] | ALX PIN [4] |
|--------------------------|-----------------|-----------------|-----------------|-------------|
| EHRPWM5_A | IO | EPWM Output A | T19 | P21 |
| EHRPWM5_B ⁽¹⁾ | IO | EPWM Output B | W19 | |

- (1) The EHRPWM5_B signal is not supported by the ALX packaged device. See [AM243x_ALX Package - Unsupported Interfaces and Signals](#) for additional details.

Table 5-26. EPWM6 Signal Descriptions

| SIGNAL NAME [1] ⁽¹⁾ | SIGNAL TYPE [2] | DESCRIPTION [3] | ALV/ANI PIN [4] | ALX PIN [4] |
|--------------------------------|-----------------|---|-----------------|-------------|
| EHRPWM6_A | IO | EPWM Output A | B14, N16 | |
| EHRPWM6_B | IO | EPWM Output B | A15, N17 | |
| EHRPWM6_SYNCI | I | Sync Input to EPWM module from an external pin | C14, R19 | |
| EHRPWM6_SYNCO | O | Sync Output from EPWM module to an external pin | B15, R20 | |

- (1) The EPWM6 interface is not supported by the ALX packaged devices. See [AM243x_ALX Package - Unsupported Interfaces and Signals](#) for additional details.

Table 5-27. EPWM7 Signal Descriptions

| SIGNAL NAME [1] | SIGNAL TYPE [2] | DESCRIPTION [3] | ALV/ANI PIN [4] | ALX PIN [4] |
|-----------------|-----------------|-----------------|-----------------|-------------|
| EHRPWM7_A | IO | EPWM Output A | P17, P5, W20 | D1, W20 |
| EHRPWM7_B | IO | EPWM Output B | R2, W21, Y18 | F3, Y20 |

Table 5-28. EPWM8 Signal Descriptions

| SIGNAL NAME [1] | SIGNAL TYPE [2] | DESCRIPTION [3] | ALV/ANI PIN [4] | ALX PIN [4] |
|-----------------|-----------------|-----------------|-----------------|-------------|
| EHRPWM8_A | IO | EPWM Output A | V1, V21 | K4, U19 |
| EHRPWM8_B | IO | EPWM Output B | R16, W1 | G2, V20 |

5.3.9 EQEP

MAIN Domain Instances

Table 5-29. EQEP0 Signal Descriptions

| SIGNAL NAME [1] | SIGNAL TYPE [2] | DESCRIPTION [3] | ALV/ANI PIN [4] | ALX PIN [4] |
|------------------------|-----------------|-------------------------|------------------|-------------|
| EQEP0_A ⁽¹⁾ | I | EQEP Quadrature Input A | D15, N16, Y2 | B10, L5 |
| EQEP0_B ⁽¹⁾ | I | EQEP Quadrature Input B | C16, N17, W2 | B11, J2 |
| EQEP0_I ⁽¹⁾ | IO | EQEP Index | A16, R20, T6, Y5 | A9, R2, T4 |
| EQEP0_S ⁽¹⁾ | IO | EQEP Strobe | B16, R19, V3 | B9, M2 |

(1) This EQEP input signal has a debounce function. For more information on I/O Debounce configuration, see the TRM *Device Configuration* chapter.

Table 5-30. EQEP1 Signal Descriptions

| SIGNAL NAME [1] | SIGNAL TYPE [2] | DESCRIPTION [3] | ALV/ANI PIN [4] | ALX PIN [4] |
|------------------------|-----------------|-------------------------|------------------|--------------|
| EQEP1_A ⁽¹⁾ | I | EQEP Quadrature Input A | E15, T4, W20 | B12, L2, W20 |
| EQEP1_B ⁽¹⁾ | I | EQEP Quadrature Input B | E14, W21, W3 | A12, L3, Y20 |
| EQEP1_I ⁽¹⁾ | IO | EQEP Index | E16, R21, U6, V6 | A11, R5, U2 |
| EQEP1_S ⁽¹⁾ | IO | EQEP Strobe | D16, P19, P4 | C11, E3 |

(1) This EQEP input signal has a debounce function. For more information on I/O Debounce configuration, see the TRM *Device Configuration* chapter.

Table 5-31. EQEP2 Signal Descriptions

| SIGNAL NAME [1] | SIGNAL TYPE [2] | DESCRIPTION [3] | ALV/ANI PIN [4] | ALX PIN [4] |
|------------------------|-----------------|-------------------------|-----------------|-------------|
| EQEP2_A ⁽¹⁾ | I | EQEP Quadrature Input A | C17, R5 | B14, F5 |
| EQEP2_B ⁽¹⁾ | I | EQEP Quadrature Input B | D17, W5, Y4 | A15, P2, T5 |
| EQEP2_I ⁽¹⁾ | IO | EQEP Index | A17, W4 | B13, P1 |
| EQEP2_S ⁽¹⁾ | IO | EQEP Strobe | B17, R1 | A14, F4 |

(1) This EQEP input signal has a debounce function. For more information on I/O Debounce configuration, see the TRM *Device Configuration* chapter.

5.3.10 FSI

MAIN Domain Instances

Table 5-32. FSI0 RX Signal Descriptions

| SIGNAL NAME [1] | SIGNAL TYPE [2] | DESCRIPTION [3] | ALV/ANI PIN [4] | ALX PIN [4] |
|-----------------|-----------------|---------------------|-----------------|-------------|
| FSI_RX0_CLK | I | FSI Receiver Clock | V19 | U18 |
| FSI_RX0_D0 | I | FSI Receiver Data 0 | T17 | U20 |
| FSI_RX0_D1 | I | FSI Receiver Data 1 | R16 | V20 |

Table 5-33. FSI0 TX Signal Descriptions

| SIGNAL NAME [1] | SIGNAL TYPE [2] | DESCRIPTION [3] | ALV/ANI PIN [4] | ALX PIN [4] |
|-----------------|-----------------|------------------------|-----------------|-------------|
| FSI_TX0_CLK | O | FSI Transmitter Clock | T19 | P21 |
| FSI_TX0_D0 | O | FSI Transmitter Data 0 | Y21 | Y18 |
| FSI_TX0_D1 | O | FSI Transmitter Data 1 | Y20 | AA19 |

Table 5-34. FSI1 RX Signal Descriptions

| SIGNAL NAME [1] | SIGNAL TYPE [2] | DESCRIPTION [3] | ALV/ANI PIN [4] | ALX PIN [4] |
|-----------------|-----------------|--------------------|-----------------|-------------|
| FSI_RX1_CLK | I | FSI Receiver Clock | W20 | W20 |

Table 5-34. FSI1 RX Signal Descriptions (continued)

| SIGNAL NAME [1] | SIGNAL TYPE [2] | DESCRIPTION [3] | ALV/ANI PIN [4] | ALX PIN [4] |
|-----------------|-----------------|---------------------|-----------------|-------------|
| FSI_RX1_D0 | I | FSI Receiver Data 0 | W21 | Y20 |
| FSI_RX1_D1 | I | FSI Receiver Data 1 | V18 | Y19 |

Table 5-35. FSI1 TX Signal Descriptions

| SIGNAL NAME [1] ⁽¹⁾ | SIGNAL TYPE [2] | DESCRIPTION [3] | ALV/ANI PIN [4] | ALX PIN [4] |
|--------------------------------|-----------------|------------------------|-----------------|-------------|
| FSI_TX1_CLK | O | FSI Transmitter Clock | N16 | |
| FSI_TX1_D0 | O | FSI Transmitter Data 0 | P17 | |
| FSI_TX1_D1 | O | FSI Transmitter Data 1 | Y18 | |

- (1) The FSI1 TX interface is not supported by the ALX packaged devices. See [AM243x_ALX Package - Unsupported Interfaces and Signals](#) for additional details.

Table 5-36. FSI2 RX Signal Descriptions

| SIGNAL NAME [1] | SIGNAL TYPE [2] | DESCRIPTION [3] | ALV/ANI PIN [4] | ALX PIN [4] |
|-----------------|-----------------|---------------------|-----------------|-------------|
| FSI_RX2_CLK | I | FSI Receiver Clock | T20 | R21 |
| FSI_RX2_D0 | I | FSI Receiver Data 0 | U21 | R20 |
| FSI_RX2_D1 | I | FSI Receiver Data 1 | T18 | T19 |

Table 5-37. FSI3 RX Signal Descriptions

| SIGNAL NAME [1] | SIGNAL TYPE [2] | DESCRIPTION [3] | ALV/ANI PIN [4] | ALX PIN [4] |
|-----------------|-----------------|---------------------|-----------------|-------------|
| FSI_RX3_CLK | I | FSI Receiver Clock | U20 | V21 |
| FSI_RX3_D0 | I | FSI Receiver Data 0 | U18 | U21 |
| FSI_RX3_D1 | I | FSI Receiver Data 1 | U19 | T20 |

Table 5-38. FSI4 RX Signal Descriptions

| SIGNAL NAME [1] ⁽¹⁾ | SIGNAL TYPE [2] | DESCRIPTION [3] | ALV/ANI PIN [4] | ALX PIN [4] |
|--------------------------------|-----------------|---------------------|-----------------|-------------|
| FSI_RX4_CLK | I | FSI Receiver Clock | R17 | |
| FSI_RX4_D0 | I | FSI Receiver Data 0 | V20 | T18 |
| FSI_RX4_D1 | I | FSI Receiver Data 1 | V21 | U19 |

- (1) The FSI4 RX interface is not supported by the ALX packaged devices. See [AM243x_ALX Package - Unsupported Interfaces and Signals](#) for additional details.

Table 5-39. FSI5 RX Signal Descriptions

| SIGNAL NAME [1] ⁽¹⁾ | SIGNAL TYPE [2] | DESCRIPTION [3] | ALV/ANI PIN [4] | ALX PIN [4] |
|--------------------------------|-----------------|---------------------|-----------------|-------------|
| FSI_RX5_CLK | I | FSI Receiver Clock | P16 | |
| FSI_RX5_D0 | I | FSI Receiver Data 0 | R18 | |
| FSI_RX5_D1 | I | FSI Receiver Data 1 | T21 | |

- (1) The FSI5 RX interface is not supported by the ALX packaged devices. See [AM243x_ALX Package - Unsupported Interfaces and Signals](#) for additional details.

5.3.11 GPIO

MAIN Domain Instances

Table 5-40. GPIO0 Signal Descriptions

| SIGNAL NAME [1] | SIGNAL TYPE [2] | DESCRIPTION [3] | ALV/ANI PIN [4] | ALX PIN [4] |
|-----------------|-----------------|------------------------------|-----------------|-------------|
| GPIO0_0 | IO | General Purpose Input/Output | N20 | P20 |

Table 5-40. GPIO0 Signal Descriptions (continued)

| SIGNAL NAME [1] | SIGNAL TYPE [2] | DESCRIPTION [3] | ALV/ANI PIN [4] | ALX PIN [4] |
|-----------------------------|-----------------|------------------------------|-----------------|-------------|
| GPIO0_1 | IO | General Purpose Input/Output | N21 | M21 |
| GPIO0_2 | IO | General Purpose Input/Output | N19 | P17 |
| GPIO0_3 | IO | General Purpose Input/Output | M19 | L19 |
| GPIO0_4 | IO | General Purpose Input/Output | M18 | N20 |
| GPIO0_5 | IO | General Purpose Input/Output | M20 | L21 |
| GPIO0_6 | IO | General Purpose Input/Output | M21 | N19 |
| GPIO0_7 ⁽²⁾ | IO | General Purpose Input/Output | P21 | |
| GPIO0_8 ⁽²⁾ | IO | General Purpose Input/Output | P20 | |
| GPIO0_9 ⁽²⁾ | IO | General Purpose Input/Output | N18 | |
| GPIO0_10 ⁽²⁾ | IO | General Purpose Input/Output | M17 | |
| GPIO0_11 | IO | General Purpose Input/Output | L19 | L20 |
| GPIO0_12 | IO | General Purpose Input/Output | L18 | M20 |
| GPIO0_13 ⁽²⁾ | IO | General Purpose Input/Output | K17 | |
| GPIO0_14 ⁽²⁾ | IO | General Purpose Input/Output | L17 | |
| GPIO0_15 | IO | General Purpose Input/Output | T20 | R21 |
| GPIO0_16 | IO | General Purpose Input/Output | U21 | R20 |
| GPIO0_17 | IO | General Purpose Input/Output | T18 | T19 |
| GPIO0_18 | IO | General Purpose Input/Output | U20 | V21 |
| GPIO0_19 | IO | General Purpose Input/Output | AA14 | AA14 |
| GPIO0_20 | IO | General Purpose Input/Output | Y13 | Y15 |
| GPIO0_21 | IO | General Purpose Input/Output | V20 | T18 |
| GPIO0_22 | IO | General Purpose Input/Output | V21 | U19 |
| GPIO0_23 | IO | General Purpose Input/Output | V19 | U18 |
| GPIO0_24 | IO | General Purpose Input/Output | T17 | U20 |
| GPIO0_25 | IO | General Purpose Input/Output | R16 | V20 |
| GPIO0_26 | IO | General Purpose Input/Output | W20 | W20 |
| GPIO0_27 | IO | General Purpose Input/Output | W21 | Y20 |
| GPIO0_28 | IO | General Purpose Input/Output | V18 | Y19 |
| GPIO0_29 | IO | General Purpose Input/Output | Y21 | Y18 |
| GPIO0_30 | IO | General Purpose Input/Output | Y20 | AA19 |
| GPIO0_31 ⁽²⁾ | IO | General Purpose Input/Output | R17 | |
| GPIO0_32 ⁽²⁾ | IO | General Purpose Input/Output | P16 | |
| GPIO0_33 ⁽²⁾ | IO | General Purpose Input/Output | R18 | |
| GPIO0_34 ⁽²⁾ | IO | General Purpose Input/Output | T21 | |
| GPIO0_35 ⁽²⁾ | IO | General Purpose Input/Output | P17 | |
| GPIO0_36 | IO | General Purpose Input/Output | T19 | P21 |
| GPIO0_37 ⁽²⁾ | IO | General Purpose Input/Output | W19 | |
| GPIO0_38 ⁽²⁾ | IO | General Purpose Input/Output | Y18 | |
| GPIO0_39 ⁽²⁾ | IO | General Purpose Input/Output | N16 | |
| GPIO0_40 ⁽²⁾ | IO | General Purpose Input/Output | N17 | |
| GPIO0_41 ⁽²⁾ | IO | General Purpose Input/Output | R19 | |
| GPIO0_42 ⁽²⁾ | IO | General Purpose Input/Output | R20 | |
| GPIO0_43 ^{(1) (2)} | IO | General Purpose Input/Output | P19 | |
| GPIO0_44 ^{(1) (2)} | IO | General Purpose Input/Output | R21 | |
| GPIO0_45 | IO | General Purpose Input/Output | Y7 | V4 |
| GPIO0_46 | IO | General Purpose Input/Output | U8 | W5 |
| GPIO0_47 | IO | General Purpose Input/Output | W8 | AA4 |
| GPIO0_48 | IO | General Purpose Input/Output | V8 | Y5 |
| GPIO0_49 | IO | General Purpose Input/Output | Y8 | AA5 |

Table 5-40. GPIO0 Signal Descriptions (continued)

| SIGNAL NAME [1] | SIGNAL TYPE [2] | DESCRIPTION [3] | ALV/ANI PIN [4] | ALX PIN [4] |
|-----------------|-----------------|------------------------------|-----------------|-------------|
| GPIO0_50 | IO | General Purpose Input/Output | V13 | U14 |
| GPIO0_51 | IO | General Purpose Input/Output | AA7 | Y2 |
| GPIO0_52 | IO | General Purpose Input/Output | U13 | V13 |
| GPIO0_53 | IO | General Purpose Input/Output | W13 | Y13 |
| GPIO0_54 | IO | General Purpose Input/Output | U15 | W16 |
| GPIO0_55 | IO | General Purpose Input/Output | U14 | W13 |
| GPIO0_56 | IO | General Purpose Input/Output | AA8 | V5 |
| GPIO0_57 | IO | General Purpose Input/Output | U9 | W2 |
| GPIO0_58 | IO | General Purpose Input/Output | W9 | V6 |
| GPIO0_59 | IO | General Purpose Input/Output | AA9 | AA7 |
| GPIO0_60 | IO | General Purpose Input/Output | Y9 | Y7 |
| GPIO0_61 | IO | General Purpose Input/Output | V9 | W6 |
| GPIO0_62 | IO | General Purpose Input/Output | U7 | T2 |
| GPIO0_63 | IO | General Purpose Input/Output | V7 | Y4 |
| GPIO0_64 | IO | General Purpose Input/Output | W7 | U3 |
| GPIO0_65 | IO | General Purpose Input/Output | W11 | AA10 |
| GPIO0_66 | IO | General Purpose Input/Output | V11 | Y10 |
| GPIO0_67 | IO | General Purpose Input/Output | AA12 | Y11 |
| GPIO0_68 | IO | General Purpose Input/Output | Y12 | V12 |
| GPIO0_69 | IO | General Purpose Input/Output | W12 | Y12 |
| GPIO0_70 | IO | General Purpose Input/Output | AA13 | AA11 |
| GPIO0_71 | IO | General Purpose Input/Output | U11 | V10 |
| GPIO0_72 | IO | General Purpose Input/Output | V15 | Y14 |
| GPIO0_73 | IO | General Purpose Input/Output | U12 | W11 |
| GPIO0_74 | IO | General Purpose Input/Output | V14 | Y16 |
| GPIO0_75 | IO | General Purpose Input/Output | W14 | U13 |
| GPIO0_76 | IO | General Purpose Input/Output | AA10 | Y6 |
| GPIO0_77 | IO | General Purpose Input/Output | V10 | AA8 |
| GPIO0_78 | IO | General Purpose Input/Output | U10 | Y9 |
| GPIO0_79 | IO | General Purpose Input/Output | AA11 | W9 |
| GPIO0_80 | IO | General Purpose Input/Output | Y11 | V9 |
| GPIO0_81 | IO | General Purpose Input/Output | Y10 | Y8 |
| GPIO0_82 | IO | General Purpose Input/Output | U18 | U21 |
| GPIO0_83 | IO | General Purpose Input/Output | U19 | T20 |
| GPIO0_84 | IO | General Purpose Input/Output | V12 | AA13 |
| GPIO0_85 | IO | General Purpose Input/Output | AA6 | V2 |
| GPIO0_86 | IO | General Purpose Input/Output | Y6 | W1 |

- (1) This GPIO input signal has a debounce function. For more information on I/O Debounce configuration, see the TRM *Device Configuration* chapter.
- (2) This GPIO0 signal is not supported by the ALX packaged device. See [AM243x_ALX Package - Unsupported Interfaces and Signals](#) for additional details.

Table 5-41. GPIO1 Signal Descriptions

| SIGNAL NAME [1] | SIGNAL TYPE [2] | DESCRIPTION [3] | ALV/ANI PIN [4] | ALX PIN [4] |
|-----------------|-----------------|------------------------------|-----------------|-------------|
| GPIO1_0 | IO | General Purpose Input/Output | Y1 | J3 |
| GPIO1_1 | IO | General Purpose Input/Output | R4 | J4 |
| GPIO1_2 | IO | General Purpose Input/Output | U2 | G1 |
| GPIO1_3 | IO | General Purpose Input/Output | V2 | H1 |
| GPIO1_4 | IO | General Purpose Input/Output | AA2 | K2 |

Table 5-41. GPIO1 Signal Descriptions (continued)

| SIGNAL NAME [1] | SIGNAL TYPE [2] | DESCRIPTION [3] | ALV/ANI PIN [4] | ALX PIN [4] |
|-------------------------|-----------------|------------------------------|-----------------|-------------|
| GPIO1_5 | IO | General Purpose Input/Output | R3 | F2 |
| GPIO1_6 | IO | General Purpose Input/Output | T3 | H2 |
| GPIO1_7 | IO | General Purpose Input/Output | T1 | E2 |
| GPIO1_8 | IO | General Purpose Input/Output | T2 | H5 |
| GPIO1_9 | IO | General Purpose Input/Output | W6 | Y3 |
| GPIO1_10 | IO | General Purpose Input/Output | AA5 | U1 |
| GPIO1_11 | IO | General Purpose Input/Output | Y3 | L1 |
| GPIO1_12 | IO | General Purpose Input/Output | AA3 | K1 |
| GPIO1_13 | IO | General Purpose Input/Output | R6 | N1 |
| GPIO1_14 | IO | General Purpose Input/Output | V4 | N2 |
| GPIO1_15 | IO | General Purpose Input/Output | T5 | N4 |
| GPIO1_16 | IO | General Purpose Input/Output | U4 | N3 |
| GPIO1_17 | IO | General Purpose Input/Output | U1 | E1 |
| GPIO1_18 | IO | General Purpose Input/Output | V1 | K4 |
| GPIO1_19 | IO | General Purpose Input/Output | W1 | G2 |
| GPIO1_20 | IO | General Purpose Input/Output | Y2 | L5 |
| GPIO1_21 | IO | General Purpose Input/Output | W2 | J2 |
| GPIO1_22 | IO | General Purpose Input/Output | V3 | M2 |
| GPIO1_23 | IO | General Purpose Input/Output | T4 | L2 |
| GPIO1_24 | IO | General Purpose Input/Output | W3 | L3 |
| GPIO1_25 | IO | General Purpose Input/Output | P4 | E3 |
| GPIO1_26 | IO | General Purpose Input/Output | R5 | F5 |
| GPIO1_27 | IO | General Purpose Input/Output | W5 | T5 |
| GPIO1_28 | IO | General Purpose Input/Output | R1 | F4 |
| GPIO1_29 | IO | General Purpose Input/Output | Y5 | R2 |
| GPIO1_30 | IO | General Purpose Input/Output | V6 | U2 |
| GPIO1_31 | IO | General Purpose Input/Output | W4 | P1 |
| GPIO1_32 | IO | General Purpose Input/Output | Y4 | P2 |
| GPIO1_33 | IO | General Purpose Input/Output | T6 | T4 |
| GPIO1_34 | IO | General Purpose Input/Output | U6 | R5 |
| GPIO1_35 | IO | General Purpose Input/Output | U5 | M4 |
| GPIO1_36 | IO | General Purpose Input/Output | AA4 | T3 |
| GPIO1_37 | IO | General Purpose Input/Output | V5 | T1 |
| GPIO1_38 | IO | General Purpose Input/Output | P5 | D1 |
| GPIO1_39 | IO | General Purpose Input/Output | R2 | F3 |
| GPIO1_40 | IO | General Purpose Input/Output | P2 | E4 |
| GPIO1_41 | IO | General Purpose Input/Output | P3 | D2 |
| GPIO1_42 ⁽²⁾ | IO | General Purpose Input/Output | D12 | |
| GPIO1_43 | IO | General Purpose Input/Output | C13 | B7 |
| GPIO1_44 | IO | General Purpose Input/Output | D13 | B8 |
| GPIO1_45 | IO | General Purpose Input/Output | A13 | A8 |
| GPIO1_46 | IO | General Purpose Input/Output | A14 | C9 |
| GPIO1_47 ⁽²⁾ | IO | General Purpose Input/Output | B14 | |
| GPIO1_48 ⁽²⁾ | IO | General Purpose Input/Output | D14 | |
| GPIO1_49 ⁽²⁾ | IO | General Purpose Input/Output | C14 | |
| GPIO1_50 ⁽²⁾ | IO | General Purpose Input/Output | B15 | |
| GPIO1_51 ⁽²⁾ | IO | General Purpose Input/Output | A15 | |
| GPIO1_52 | IO | General Purpose Input/Output | D15 | B10 |
| GPIO1_53 | IO | General Purpose Input/Output | C16 | B11 |

Table 5-41. GPIO1 Signal Descriptions (continued)

| SIGNAL NAME [1] | SIGNAL TYPE [2] | DESCRIPTION [3] | ALV/ANI PIN [4] | ALX PIN [4] |
|-----------------------------|-----------------|------------------------------|-----------------|-------------|
| GPIO1_54 | IO | General Purpose Input/Output | B16 | B9 |
| GPIO1_55 | IO | General Purpose Input/Output | A16 | A9 |
| GPIO1_56 | IO | General Purpose Input/Output | E15 | B12 |
| GPIO1_57 | IO | General Purpose Input/Output | E14 | A12 |
| GPIO1_58 | IO | General Purpose Input/Output | D16 | C11 |
| GPIO1_59 | IO | General Purpose Input/Output | E16 | A11 |
| GPIO1_60 | IO | General Purpose Input/Output | A17 | B13 |
| GPIO1_61 | IO | General Purpose Input/Output | B17 | A14 |
| GPIO1_62 | IO | General Purpose Input/Output | C17 | B14 |
| GPIO1_63 | IO | General Purpose Input/Output | D17 | A15 |
| GPIO1_64 | IOD | General Purpose Input/Output | A18 | B16 |
| GPIO1_65 | IOD | General Purpose Input/Output | B18 | B15 |
| GPIO1_66 | IO | General Purpose Input/Output | C18 | A17 |
| GPIO1_67 | IO | General Purpose Input/Output | B19 | B18 |
| GPIO1_68 ^{(1) (2)} | IO | General Purpose Input/Output | D18 | |
| GPIO1_69 | IO | General Purpose Input/Output | A19 | A18 |
| GPIO1_70 ^{(1) (2)} | IOD | General Purpose Input/Output | C19 | |
| GPIO1_71 ⁽¹⁾ | IO | General Purpose Input/Output | K18 | K18 |
| GPIO1_72 ⁽¹⁾ | IO | General Purpose Input/Output | K19 | K20 |
| GPIO1_73 ⁽¹⁾ | IO | General Purpose Input/Output | L21 | J19 |
| GPIO1_74 ⁽¹⁾ | IO | General Purpose Input/Output | K21 | J18 |
| GPIO1_75 ⁽¹⁾ | IO | General Purpose Input/Output | L20 | J20 |
| GPIO1_76 ⁽¹⁾ | IO | General Purpose Input/Output | J19 | J21 |
| GPIO1_77 ⁽¹⁾ | IO | General Purpose Input/Output | D19 | B17 |
| GPIO1_78 ⁽¹⁾ | IO | General Purpose Input/Output | C20 | C16 |
| GPIO1_79 | IO | General Purpose Input/Output | E19 | B19 |

(1) This GPIO input signal has a debounce function. For more information on I/O Debounce configuration, see the TRM *Device Configuration* chapter.

(2) This GPIO1 signal is not supported by the ALX packaged device. See [AM243x_ALX Package - Unsupported Interfaces and Signals](#) for additional details.

MCU Domain Instances

Table 5-42. MCU_GPIO0 Signal Descriptions

| SIGNAL NAME [1] | SIGNAL TYPE [2] | DESCRIPTION [3] | ALV/ANI PIN [4] | ALX PIN [4] |
|---------------------------------|-----------------|------------------------------|-----------------|-------------|
| MCU_GPIO0_0 ⁽¹⁾ | IO | General Purpose Input/Output | E8 | C2 |
| MCU_GPIO0_1 ⁽¹⁾ | IO | General Purpose Input/Output | D8 | D4 |
| MCU_GPIO0_2 | IO | General Purpose Input/Output | A8 | B2 |
| MCU_GPIO0_3 | IO | General Purpose Input/Output | A9 | D6 |
| MCU_GPIO0_4 ⁽²⁾ | IO | General Purpose Input/Output | B6 | |
| MCU_GPIO0_5 ^{(1) (2)} | IO | General Purpose Input/Output | A7 | |
| MCU_GPIO0_6 ^{(1) (2)} | IO | General Purpose Input/Output | B7 | |
| MCU_GPIO0_7 ⁽²⁾ | IO | General Purpose Input/Output | D7 | |
| MCU_GPIO0_8 ⁽²⁾ | IO | General Purpose Input/Output | C7 | |
| MCU_GPIO0_9 ⁽²⁾ | IO | General Purpose Input/Output | C8 | |
| MCU_GPIO0_10 ⁽²⁾ | IO | General Purpose Input/Output | E7 | |
| MCU_GPIO0_11 ⁽²⁾ | IO | General Purpose Input/Output | E6 | |
| MCU_GPIO0_12 ^{(1) (2)} | IO | General Purpose Input/Output | C6 | |
| MCU_GPIO0_13 ^{(1) (2)} | IO | General Purpose Input/Output | D6 | |
| MCU_GPIO0_14 ⁽²⁾ | IO | General Purpose Input/Output | C9 | |

Table 5-42. MCU_GPIO0 Signal Descriptions (continued)

| SIGNAL NAME [1] | SIGNAL TYPE [2] | DESCRIPTION [3] | ALV/ANI PIN [4] | ALX PIN [4] |
|----------------------|-----------------|------------------------------|-----------------|-------------|
| MCU_GPIO0_15 (2) | IO | General Purpose Input/Output | D9 | |
| MCU_GPIO0_16 (1) (2) | IO | General Purpose Input/Output | B8 | |
| MCU_GPIO0_17 (1) (2) | IO | General Purpose Input/Output | B9 | |
| MCU_GPIO0_18 (2) | IOD | General Purpose Input/Output | E9 | |
| MCU_GPIO0_19 (2) | IOD | General Purpose Input/Output | A10 | |
| MCU_GPIO0_20 (1) (2) | IO | General Purpose Input/Output | A11 | |
| MCU_GPIO0_21 (1) (2) | IO | General Purpose Input/Output | B10 | |
| MCU_GPIO0_22 | IO | General Purpose Input/Output | B13 | A6 |

- (1) This GPIO input signal has a debounce function. For more information on I/O Debounce configuration, see the TRM *Device Configuration* chapter.
- (2) This MCU_GPIO0 signal is not supported by the ALX packaged device. See [AM243x_ALX Package - Unsupported Interfaces and Signals](#) for additional details.

5.3.12 GPMC

MAIN Domain Instances

Table 5-43. GPMC0 Signal Descriptions

| SIGNAL NAME [1] (2) | SIGNAL TYPE [2] | DESCRIPTION [3] | ALV/ANI PIN [4] | ALX PIN [4] |
|---------------------|-----------------|---|-----------------|-------------|
| GPMC0_ADVn_ALE | O | GPMC Address Valid (active low) or Address Latch Enable | P16 | |
| GPMC0_CLK | O | GPMC Clock | R17 | |
| GPMC0_DIR | O | GPMC Data Bus Signal Direction Control | N17 | |
| GPMC0_FCLK_MUX (1) | O | GPMC functional clock output selected through mux logic | R17 | |
| GPMC0_OEn_REn | O | GPMC Output Enable (active low) or Read Enable (active low) | R18 | |
| GPMC0_WEn | O | GPMC Write Enable (active low) | T21 | |
| GPMC0_WPn | O | GPMC Flash Write Protect (active low) | N16 | |
| GPMC0_A0 | OZ | GPMC Address 0 Output. Only used to effectively address 8-bit data non-multiplexed memories | U2, U7 | G1, T2 |
| GPMC0_A1 | OZ | GPMC address 1 Output in A/D non-multiplexed mode and Address 17 in A/D multiplexed mode | AA2, V7 | K2, Y4 |
| GPMC0_A2 | OZ | GPMC address 2 Output in A/D non-multiplexed mode and Address 18 in A/D multiplexed mode | T2, W7 | H5, U3 |
| GPMC0_A3 | OZ | GPMC address 3 Output in A/D non-multiplexed mode and Address 19 in A/D multiplexed mode | V4, W11 | AA10, N2 |
| GPMC0_A4 | OZ | GPMC address 4 Output in A/D non-multiplexed mode and Address 20 in A/D multiplexed mode | U4, V11 | N3, Y10 |
| GPMC0_A5 | OZ | GPMC address 5 Output in A/D non-multiplexed mode and Address 21 in A/D multiplexed mode | AA12, V1 | K4, Y11 |
| GPMC0_A6 | OZ | GPMC address 6 Output in A/D non-multiplexed mode and Address 22 in A/D multiplexed mode | W1, Y12 | G2, V12 |
| GPMC0_A7 | OZ | GPMC address 7 Output in A/D non-multiplexed mode and Address 23 in A/D multiplexed mode | W12, Y4 | P2, Y12 |
| GPMC0_A8 | OZ | GPMC address 8 Output in A/D non-multiplexed mode and Address 24 in A/D multiplexed mode | AA13, T6 | AA11, T4 |
| GPMC0_A9 | OZ | GPMC address 9 Output in A/D non-multiplexed mode and Address 25 in A/D multiplexed mode | U11, U6 | R5, V10 |
| GPMC0_A10 | OZ | GPMC address 10 Output in A/D non-multiplexed mode and Address 26 in A/D multiplexed mode | U5, V15 | M4, Y14 |
| GPMC0_A11 | OZ | GPMC address 11 Output in A/D non-multiplexed mode and unused in A/D multiplexed mode | AA4, U12 | T3, W11 |
| GPMC0_A12 | OZ | GPMC address 12 Output in A/D non-multiplexed mode and unused in A/D multiplexed mode | P2, V14 | E4, Y16 |
| GPMC0_A13 | OZ | GPMC address 13 Output in A/D non-multiplexed mode and unused in A/D multiplexed mode | P3, W14 | D2, U13 |
| GPMC0_A14 | OZ | GPMC address 14 Output in A/D non-multiplexed mode and unused in A/D multiplexed mode | AA10, AA3 | K1, Y6 |

Table 5-43. GPMC0 Signal Descriptions (continued)

| SIGNAL NAME [1] (2) | SIGNAL TYPE [2] | DESCRIPTION [3] | ALV/ANI PIN [4] | ALX PIN [4] |
|---------------------|-----------------|--|-----------------|-------------|
| GPMC0_A15 | OZ | GPMC address 15 Output in A/D non-multiplexed mode and unused in A/D multiplexed mode | R6, V10 | AA8, N1 |
| GPMC0_A16 | OZ | GPMC address 16 Output in A/D non-multiplexed mode and unused in A/D multiplexed mode | T5, U10 | N4, Y9 |
| GPMC0_A17 | OZ | GPMC address 17 Output in A/D non-multiplexed mode and unused in A/D multiplexed mode | AA11, U1 | E1, W9 |
| GPMC0_A18 | OZ | GPMC address 18 Output in A/D non-multiplexed mode and unused in A/D multiplexed mode | T4, Y11 | L2, V9 |
| GPMC0_A19 | OZ | GPMC address 19 Output in A/D non-multiplexed mode and unused in A/D multiplexed mode | R5, Y10 | F5, Y8 |
| GPMC0_A20 | OZ | GPMC address 20 Output in A/D non-multiplexed mode and unused in A/D multiplexed mode | R21 | |
| GPMC0_A21 | OZ | GPMC address 21 Output in A/D non-multiplexed mode and unused in A/D multiplexed mode | Y18 | |
| GPMC0_A22 | OZ | GPMC address 22 Output in A/D non-multiplexed mode and unused in A/D multiplexed mode | N16 | |
| GPMC0_AD0 | IO | GPMC Data 0 Input/Output in A/D non-multiplexed mode and additionally Address 1 Output in A/D multiplexed mode | T20 | R21 |
| GPMC0_AD1 | IO | GPMC Data 1 Input/Output in A/D non-multiplexed mode and additionally Address 2 Output in A/D multiplexed mode | U21 | R20 |
| GPMC0_AD2 | IO | GPMC Data 2 Input/Output in A/D non-multiplexed mode and additionally Address 3 Output in A/D multiplexed mode | T18 | T19 |
| GPMC0_AD3 | IO | GPMC Data 3 Input/Output in A/D non-multiplexed mode and additionally Address 4 Output in A/D multiplexed mode | U20 | V21 |
| GPMC0_AD4 | IO | GPMC Data 4 Input/Output in A/D non-multiplexed mode and additionally Address 5 Output in A/D multiplexed mode | U18 | U21 |
| GPMC0_AD5 | IO | GPMC Data 5 Input/Output in A/D non-multiplexed mode and additionally Address 6 Output in A/D multiplexed mode | U19 | T20 |
| GPMC0_AD6 | IO | GPMC Data 6 Input/Output in A/D non-multiplexed mode and additionally Address 7 Output in A/D multiplexed mode | V20 | T18 |
| GPMC0_AD7 | IO | GPMC Data 7 Input/Output in A/D non-multiplexed mode and additionally Address 8 Output in A/D multiplexed mode | V21 | U19 |
| GPMC0_AD8 | IO | GPMC Data 8 Input/Output in A/D non-multiplexed mode and additionally Address 9 Output in A/D multiplexed mode | V19 | U18 |
| GPMC0_AD9 | IO | GPMC Data 9 Input/Output in A/D non-multiplexed mode and additionally Address 10 Output in A/D multiplexed mode | T17 | U20 |
| GPMC0_AD10 | IO | GPMC Data 10 Input/Output in A/D non-multiplexed mode and additionally Address 11 Output in A/D multiplexed mode | R16 | V20 |
| GPMC0_AD11 | IO | GPMC Data 11 Input/Output in A/D non-multiplexed mode and additionally Address 12 Output in A/D multiplexed mode | W20 | W20 |
| GPMC0_AD12 | IO | GPMC Data 12 Input/Output in A/D non-multiplexed mode and additionally Address 13 Output in A/D multiplexed mode | W21 | Y20 |
| GPMC0_AD13 | IO | GPMC Data 13 Input/Output in A/D non-multiplexed mode and additionally Address 14 Output in A/D multiplexed mode | V18 | Y19 |
| GPMC0_AD14 | IO | GPMC Data 14 Input/Output in A/D non-multiplexed mode and additionally Address 15 Output in A/D multiplexed mode | Y21 | Y18 |
| GPMC0_AD15 | IO | GPMC Data 15 Input/Output in A/D non-multiplexed mode and additionally Address 16 Output in A/D multiplexed mode | Y20 | AA19 |
| GPMC0_AD16 | IO | GPMC Data 16 Input/Output in A/D non-multiplexed mode and additionally Address 17 Output in A/D multiplexed mode | Y7 | V4 |
| GPMC0_AD17 | IO | GPMC Data 17 Input/Output in A/D non-multiplexed mode and additionally Address 18 Output in A/D multiplexed mode | U8 | W5 |
| GPMC0_AD18 | IO | GPMC Data 18 Input/Output in A/D non-multiplexed mode and additionally Address 19 Output in A/D multiplexed mode | W8 | AA4 |
| GPMC0_AD19 | IO | GPMC Data 19 Input/Output in A/D non-multiplexed mode and additionally Address 20 Output in A/D multiplexed mode | V8 | Y5 |
| GPMC0_AD20 | IO | GPMC Data 20 Input/Output in A/D non-multiplexed mode and additionally Address 21 Output in A/D multiplexed mode | Y8 | AA5 |

Table 5-43. GPMC0 Signal Descriptions (continued)

| SIGNAL NAME [1] (2) | SIGNAL TYPE [2] | DESCRIPTION [3] | ALV/ANI PIN [4] | ALX PIN [4] |
|---------------------|-----------------|--|-----------------|-------------|
| GPMC0_AD21 | IO | GPMC Data 21 Input/Output in A/D non-multiplexed mode and additionally Address 22 Output in A/D multiplexed mode | V13 | U14 |
| GPMC0_AD22 | IO | GPMC Data 22 Input/Output in A/D non-multiplexed mode and additionally Address 23 Output in A/D multiplexed mode | AA7 | Y2 |
| GPMC0_AD23 | IO | GPMC Data 23 Input/Output in A/D non-multiplexed mode and additionally Address 24 Output in A/D multiplexed mode | U13 | V13 |
| GPMC0_AD24 | IO | GPMC Data 24 Input/Output in A/D non-multiplexed mode and additionally Address 25 Output in A/D multiplexed mode | W13 | Y13 |
| GPMC0_AD25 | IO | GPMC Data 25 Input/Output in A/D non-multiplexed mode and additionally Address 26 Output in A/D multiplexed mode | U15 | W16 |
| GPMC0_AD26 | IO | GPMC Data 26 Input/Output in A/D non-multiplexed mode and additionally Address 27 Output in A/D multiplexed mode | U14 | W13 |
| GPMC0_AD27 | IO | GPMC Data 27 Input/Output in A/D non-multiplexed mode and additionally Address 28 Output in A/D multiplexed mode | AA8 | V5 |
| GPMC0_AD28 | IO | GPMC Data 28 Input/Output in A/D non-multiplexed mode and additionally Address 29 Output in A/D multiplexed mode | U9 | W2 |
| GPMC0_AD29 | IO | GPMC Data 29 Input/Output in A/D non-multiplexed mode and additionally Address 30 Output in A/D multiplexed mode | W9 | V6 |
| GPMC0_AD30 | IO | GPMC Data 30 Input/Output in A/D non-multiplexed mode and additionally Address 31 Output in A/D multiplexed mode | AA9 | AA7 |
| GPMC0_AD31 | IO | GPMC Data 31 Input/Output in A/D non-multiplexed mode and additionally Address 0 Output in A/D multiplexed mode | Y9 | Y7 |
| GPMC0_BE0n_CLE | O | GPMC Lower-Byte Enable (active low) or Command Latch Enable | P17 | |
| GPMC0_BE1n | O | GPMC Upper-Byte Enable (active low) | T19 | P21 |
| GPMC0_BE2n | O | GPMC Upper-Byte Enable (active low) | V9 | W6 |
| GPMC0_BE3n | O | GPMC Upper-Byte Enable (active low) | AA14 | AA14 |
| GPMC0_CSn0 | O | GPMC Chip Select 0 (active low) | R19 | |
| GPMC0_CSn1 | O | GPMC Chip Select 1 (active low) | R20 | |
| GPMC0_CSn2 | O | GPMC Chip Select 2 (active low) | P19 | |
| GPMC0_CSn3 | O | GPMC Chip Select 3 (active low) | R21 | |
| GPMC0_WAIT0 | I | GPMC External Indication of Wait | W19 | |
| GPMC0_WAIT1 | I | GPMC External Indication of Wait | Y18 | |

- (1) The GPMC0_FCLK_MUX signal is not supported by the ALX packaged device. See [AM243x_ALX Package - Unsupported Interfaces and Signals](#) for additional details.
- (2) The GPMC0 interface is not supported by the ALX packaged devices. See [AM243x_ALX Package - Unsupported Interfaces and Signals](#) for additional details.

5.3.12.1 GPMC0 IOSETs (ALV/ANI)

Table 5-44 defines valid pin combinations of each ALV/ANI package GPMC0 IOSET.

Table 5-44. GPMC0 IOSETs (ALV/ANI)

| SIGNALS | IOSET1 | | IOSET2 | |
|----------------|---------------------|---------|---------------------|---------|
| | BALL NAME (ALV/ANI) | MUXMODE | BALL NAME (ALV/ANI) | MUXMODE |
| GPMC0_AD0 | GPMC0_AD0 | 0 | GPMC0_AD0 | 0 |
| GPMC0_AD1 | GPMC0_AD1 | 0 | GPMC0_AD1 | 0 |
| GPMC0_AD2 | GPMC0_AD2 | 0 | GPMC0_AD2 | 0 |
| GPMC0_AD3 | GPMC0_AD3 | 0 | GPMC0_AD3 | 0 |
| GPMC0_AD4 | GPMC0_AD4 | 0 | GPMC0_AD4 | 0 |
| GPMC0_AD5 | GPMC0_AD5 | 0 | GPMC0_AD5 | 0 |
| GPMC0_AD6 | GPMC0_AD6 | 0 | GPMC0_AD6 | 0 |
| GPMC0_AD7 | GPMC0_AD7 | 0 | GPMC0_AD7 | 0 |
| GPMC0_AD8 | GPMC0_AD8 | 0 | GPMC0_AD8 | 0 |
| GPMC0_AD9 | GPMC0_AD9 | 0 | GPMC0_AD9 | 0 |
| GPMC0_AD10 | GPMC0_AD10 | 0 | GPMC0_AD10 | 0 |
| GPMC0_AD11 | GPMC0_AD11 | 0 | GPMC0_AD11 | 0 |
| GPMC0_AD12 | GPMC0_AD12 | 0 | GPMC0_AD12 | 0 |
| GPMC0_AD13 | GPMC0_AD13 | 0 | GPMC0_AD13 | 0 |
| GPMC0_AD14 | GPMC0_AD14 | 0 | GPMC0_AD14 | 0 |
| GPMC0_AD15 | GPMC0_AD15 | 0 | GPMC0_AD15 | 0 |
| GPMC0_CLK | GPMC0_CLK | 0 | GPMC0_CLK | 0 |
| GPMC0_ADVn_ALE | GPMC0_ADVn_ALE | 0 | GPMC0_ADVn_ALE | 0 |
| GPMC0_OEn_REn | GPMC0_OEn_REn | 0 | GPMC0_OEn_REn | 0 |
| GPMC0_WEn | GPMC0_WEn | 0 | GPMC0_WEn | 0 |
| GPMC0_BE0n_CLE | GPMC0_BE0n_CLE | 0 | GPMC0_BE0n_CLE | 0 |
| GPMC0_BE1n | GPMC0_BE1n | 0 | GPMC0_BE1n | 0 |
| GPMC0_WAIT0 | GPMC0_WAIT0 | 0 | GPMC0_WAIT0 | 0 |
| GPMC0_WAIT1 | GPMC0_WAIT1 | 0 | GPMC0_WAIT1 | 0 |
| GPMC0_WPn | GPMC0_WPn | 0 | GPMC0_WPn | 0 |
| GPMC0_DIR | GPMC0_DIR | 0 | GPMC0_DIR | 0 |
| GPMC0_CSn0 | GPMC0_CSn0 | 0 | GPMC0_CSn0 | 0 |
| GPMC0_CSn1 | GPMC0_CSn1 | 0 | GPMC0_CSn1 | 0 |
| GPMC0_CSn2 | GPMC0_CSn2 | 0 | GPMC0_CSn2 | 0 |
| GPMC0_CSn3 | GPMC0_CSn3 | 0 | GPMC0_CSn3 | 0 |
| GPMC0_AD16 | PRG1_PRU0_GPO0 | 8 | PRG1_PRU0_GPO0 | 8 |
| GPMC0_AD17 | PRG1_PRU0_GPO1 | 8 | PRG1_PRU0_GPO1 | 8 |
| GPMC0_AD18 | PRG1_PRU0_GPO2 | 8 | PRG1_PRU0_GPO2 | 8 |
| GPMC0_AD19 | PRG1_PRU0_GPO3 | 8 | PRG1_PRU0_GPO3 | 8 |
| GPMC0_AD20 | PRG1_PRU0_GPO4 | 8 | PRG1_PRU0_GPO4 | 8 |
| GPMC0_AD21 | PRG1_PRU0_GPO5 | 8 | PRG1_PRU0_GPO5 | 8 |
| GPMC0_AD22 | PRG1_PRU0_GPO6 | 8 | PRG1_PRU0_GPO6 | 8 |
| GPMC0_AD23 | PRG1_PRU0_GPO7 | 8 | PRG1_PRU0_GPO7 | 8 |
| GPMC0_AD24 | PRG1_PRU0_GPO8 | 8 | PRG1_PRU0_GPO8 | 8 |
| GPMC0_AD25 | PRG1_PRU0_GPO9 | 8 | PRG1_PRU0_GPO9 | 8 |
| GPMC0_AD26 | PRG1_PRU0_GPO10 | 8 | PRG1_PRU0_GPO10 | 8 |

Table 5-44. GPMC0 IOSETs (ALV/ANI) (continued)

| SIGNALS | IOSET1 | | IOSET2 | |
|------------|---------------------|---------|---------------------|---------|
| | BALL NAME (ALV/ANI) | MUXMODE | BALL NAME (ALV/ANI) | MUXMODE |
| GPMC0_AD27 | PRG1_PRU0_GPO11 | 8 | PRG1_PRU0_GPO11 | 8 |
| GPMC0_AD28 | PRG1_PRU0_GPO12 | 8 | PRG1_PRU0_GPO12 | 8 |
| GPMC0_AD29 | PRG1_PRU0_GPO13 | 8 | PRG1_PRU0_GPO13 | 8 |
| GPMC0_AD30 | PRG1_PRU0_GPO14 | 8 | PRG1_PRU0_GPO14 | 8 |
| GPMC0_AD31 | PRG1_PRU0_GPO15 | 8 | PRG1_PRU0_GPO15 | 8 |
| GPMC0_BE2n | PRG1_PRU0_GPO16 | 8 | PRG1_PRU0_GPO16 | 8 |
| GPMC0_A0 | PRG1_PRU0_GPO17 | 8 | PRG0_PRU0_GPO2 | 9 |
| GPMC0_A1 | PRG1_PRU0_GPO18 | 8 | PRG0_PRU0_GPO4 | 9 |
| GPMC0_A2 | PRG1_PRU0_GPO19 | 8 | PRG0_PRU0_GPO8 | 9 |
| GPMC0_A3 | PRG1_PRU1_GPO0 | 8 | PRG0_PRU0_GPO14 | 9 |
| GPMC0_A4 | PRG1_PRU1_GPO1 | 8 | PRG0_PRU0_GPO16 | 9 |
| GPMC0_A5 | PRG1_PRU1_GPO2 | 8 | PRG0_PRU0_GPO18 | 9 |
| GPMC0_A6 | PRG1_PRU1_GPO3 | 8 | PRG0_PRU0_GPO19 | 9 |
| GPMC0_A7 | PRG1_PRU1_GPO4 | 8 | PRG0_PRU1_GPO12 | 9 |
| GPMC0_A8 | PRG1_PRU1_GPO5 | 8 | PRG0_PRU1_GPO13 | 9 |
| GPMC0_A9 | PRG1_PRU1_GPO6 | 8 | PRG0_PRU1_GPO14 | 9 |
| GPMC0_A10 | PRG1_PRU1_GPO7 | 8 | PRG0_PRU1_GPO15 | 9 |
| GPMC0_A11 | PRG1_PRU1_GPO8 | 8 | PRG0_PRU1_GPO16 | 9 |
| GPMC0_A12 | PRG1_PRU1_GPO9 | 8 | PRG0_MDIO0_MDIO | 9 |
| GPMC0_A13 | PRG1_PRU1_GPO10 | 8 | PRG0_MDIO0_MDC | 9 |
| GPMC0_A14 | PRG1_PRU1_GPO11 | 8 | PRG0_PRU0_GPO12 | 9 |
| GPMC0_A15 | PRG1_PRU1_GPO12 | 8 | PRG0_PRU0_GPO13 | 9 |
| GPMC0_A16 | PRG1_PRU1_GPO13 | 8 | PRG0_PRU0_GPO15 | 9 |
| GPMC0_A17 | PRG1_PRU1_GPO14 | 8 | PRG0_PRU0_GPO17 | 9 |
| GPMC0_A18 | PRG1_PRU1_GPO15 | 8 | PRG0_PRU1_GPO3 | 9 |
| GPMC0_A19 | PRG1_PRU1_GPO16 | 8 | PRG0_PRU1_GPO6 | 9 |
| GPMC0_BE3n | PRG1_PRU1_GPO17 | 8 | PRG1_PRU1_GPO17 | 8 |
| GPMC0_A20 | GPMC0_CSn3 | 4 | GPMC0_CSn3 | 4 |
| GPMC0_A21 | GPMC0_WAIT1 | 4 | GPMC0_WAIT1 | 4 |
| GPMC0_A22 | GPMC0_WPn | 4 | GPMC0_WPn | 4 |

5.3.13 I2C

MAIN Domain Instances

Table 5-45. I2C0 Signal Descriptions

| SIGNAL NAME [1] | SIGNAL TYPE [2] | DESCRIPTION [3] | ALV/ANI PIN [4] | ALX PIN [4] |
|-----------------|-----------------|-----------------|-----------------|-------------|
| I2C0_SCL | IOD | I2C Clock | A18 | B16 |
| I2C0_SDA | IOD | I2C Data | B18 | B15 |

Table 5-46. I2C1 Signal Descriptions

| SIGNAL NAME [1] | SIGNAL TYPE [2] | DESCRIPTION [3] | ALV/ANI PIN [4] | ALX PIN [4] |
|-----------------|-----------------|-----------------|-----------------|-------------|
| I2C1_SCL | IOD | I2C Clock | C18 | A17 |
| I2C1_SDA | IOD | I2C Data | B19 | B18 |

Table 5-47. I2C2 Signal Descriptions

| SIGNAL NAME [1] ⁽¹⁾ | SIGNAL TYPE [2] | DESCRIPTION [3] | ALV/ANI PIN [4] | ALX PIN [4] |
|--------------------------------|-----------------|-----------------|-----------------|-------------|
| I2C2_SCL | IOD | I2C Clock | C13, P19 | B7 |
| I2C2_SDA | IOD | I2C Data | D14, R21 | |

(1) The I2C2 interface is not supported by the ALX packaged devices. See [AM243x_ALX Package - Unsupported Interfaces and Signals](#) for additional details.

Table 5-48. I2C3 Signal Descriptions

| SIGNAL NAME [1] | SIGNAL TYPE [2] | DESCRIPTION [3] | ALV/ANI PIN [4] | ALX PIN [4] |
|-----------------|-----------------|-----------------|-----------------|-------------|
| I2C3_SCL | IOD | I2C Clock | C17 | B14 |
| I2C3_SDA | IOD | I2C Data | D17 | A15 |

MCU Domain Instances**Table 5-49. MCU_I2C0 Signal Descriptions**

| SIGNAL NAME [1] ⁽¹⁾ | SIGNAL TYPE [2] | DESCRIPTION [3] | ALV/ANI PIN [4] | ALX PIN [4] |
|--------------------------------|-----------------|-----------------|-----------------|-------------|
| MCU_I2C0_SCL | IOD | I2C Clock | E9 | |
| MCU_I2C0_SDA | IOD | I2C Data | A10 | |

(1) The MCU_I2C0 interface is not supported by the ALX packaged devices. See [AM243x_ALX Package - Unsupported Interfaces and Signals](#) for additional details.

Table 5-50. MCU_I2C1 Signal Descriptions

| SIGNAL NAME [1] ⁽¹⁾ | SIGNAL TYPE [2] | DESCRIPTION [3] | ALV/ANI PIN [4] | ALX PIN [4] |
|--------------------------------|-----------------|-----------------|-----------------|-------------|
| MCU_I2C1_SCL | IOD | I2C Clock | A11 | |
| MCU_I2C1_SDA | IOD | I2C Data | B10 | |

(1) The MCU_I2C1 interface is not supported by the ALX packaged devices. See [AM243x_ALX Package - Unsupported Interfaces and Signals](#) for additional details.

5.3.14 MCAN**MAIN Domain Instances****Table 5-51. MCAN0 Signal Descriptions**

| SIGNAL NAME [1] | SIGNAL TYPE [2] | DESCRIPTION [3] | ALV/ANI PIN [4] | ALX PIN [4] |
|-----------------|-----------------|--------------------|-----------------|-------------|
| MCAN0_RX | I | MCAN Receive Data | B17 | A14 |
| MCAN0_TX | O | MCAN Transmit Data | A17 | B13 |

Table 5-52. MCAN1 Signal Descriptions

| SIGNAL NAME [1] | SIGNAL TYPE [2] | DESCRIPTION [3] | ALV/ANI PIN [4] | ALX PIN [4] |
|-----------------|-----------------|--------------------|-----------------|-------------|
| MCAN1_RX | I | MCAN Receive Data | D17 | A15 |
| MCAN1_TX | O | MCAN Transmit Data | C17 | B14 |

5.3.15 SPI (MCSPi)**MAIN Domain Instances****Table 5-53. MCSPi0 Signal Descriptions**

| SIGNAL NAME [1] | SIGNAL TYPE [2] | DESCRIPTION [3] | ALV/ANI PIN [4] | ALX PIN [4] |
|-------------------------|-----------------|-------------------|-----------------|-------------|
| SPI0_CLK | IO | SPI Clock | D13 | B8 |
| SPI0_CS0 ⁽¹⁾ | IO | SPI Chip Select 0 | D12 | |
| SPI0_CS1 | IO | SPI Chip Select 1 | C13 | B7 |

Table 5-53. MCSPI0 Signal Descriptions (continued)

| SIGNAL NAME [1] | SIGNAL TYPE [2] | DESCRIPTION [3] | ALV/ANI PIN [4] | ALX PIN [4] |
|-----------------|-----------------|-------------------|-----------------|-------------|
| SPI0_CS2 | IO | SPI Chip Select 2 | B16 | B9 |
| SPI0_CS3 | IO | SPI Chip Select 3 | A16 | A9 |
| SPI0_D0 | IO | SPI Data 0 | A13 | A8 |
| SPI0_D1 | IO | SPI Data 1 | A14 | C9 |

(1) The SPI0_CS0 signal is not supported by the ALX packaged device. See [AM243x_ALX Package - Unsupported Interfaces and Signals](#) for additional details.

Table 5-54. MCSPI1 Signal Descriptions

| SIGNAL NAME [1] ⁽¹⁾ | SIGNAL TYPE [2] | DESCRIPTION [3] | ALV/ANI PIN [4] | ALX PIN [4] |
|--------------------------------|-----------------|-------------------|-----------------|-------------|
| SPI1_CLK | IO | SPI Clock | C14 | |
| SPI1_CS0 | IO | SPI Chip Select 0 | B14 | |
| SPI1_CS1 | IO | SPI Chip Select 1 | D14 | |
| SPI1_CS2 | IO | SPI Chip Select 2 | D16 | C11 |
| SPI1_CS3 | IO | SPI Chip Select 3 | E16 | A11 |
| SPI1_D0 | IO | SPI Data 0 | B15 | |
| SPI1_D1 | IO | SPI Data 1 | A15 | |

(1) The SPI1 interface is not supported by the ALX packaged devices. See [AM243x_ALX Package - Unsupported Interfaces and Signals](#) for additional details.

Table 5-55. MCSPI2 Signal Descriptions

| SIGNAL NAME [1] | SIGNAL TYPE [2] | DESCRIPTION [3] | ALV/ANI PIN [4] | ALX PIN [4] |
|-----------------|-----------------|-------------------|-----------------|-------------|
| SPI2_CLK | IO | SPI Clock | E14 | A12 |
| SPI2_CS0 | IO | SPI Chip Select 0 | E15 | B12 |
| SPI2_CS1 | IO | SPI Chip Select 1 | C18 | A17 |
| SPI2_CS2 | IO | SPI Chip Select 2 | B19 | B18 |
| SPI2_CS3 | IO | SPI Chip Select 3 | A19 | A18 |
| SPI2_D0 | IO | SPI Data 0 | D15 | B10 |
| SPI2_D1 | IO | SPI Data 1 | C16 | B11 |

Table 5-56. MCSPI3 Signal Descriptions

| SIGNAL NAME [1] | SIGNAL TYPE [2] | DESCRIPTION [3] | ALV/ANI PIN [4] | ALX PIN [4] |
|-----------------|-----------------|-------------------|-----------------|-------------|
| SPI3_CLK | IO | SPI Clock | U4 | N3 |
| SPI3_CS0 | IO | SPI Chip Select 0 | U1 | E1 |
| SPI3_CS1 | IO | SPI Chip Select 1 | T5 | N4 |
| SPI3_CS2 | IO | SPI Chip Select 2 | V12 | AA13 |
| SPI3_CS3 | IO | SPI Chip Select 3 | V15 | Y14 |
| SPI3_D0 | IO | SPI Data 0 | R6 | N1 |
| SPI3_D1 | IO | SPI Data 1 | V4 | N2 |

Table 5-57. MCSPI4 Signal Descriptions

| SIGNAL NAME [1] | SIGNAL TYPE [2] | DESCRIPTION [3] | ALV/ANI PIN [4] | ALX PIN [4] |
|-------------------------|-----------------|-------------------|-----------------|-------------|
| SPI4_CLK | IO | SPI Clock | B16 | B9 |
| SPI4_CS0 | IO | SPI Chip Select 0 | E16 | A11 |
| SPI4_CS1 | IO | SPI Chip Select 1 | A17 | B13 |
| SPI4_CS2 | IO | SPI Chip Select 2 | B17 | A14 |
| SPI4_CS3 ⁽¹⁾ | IO | SPI Chip Select 3 | D18 | |

Table 5-57. MCSPi4 Signal Descriptions (continued)

| SIGNAL NAME [1] | SIGNAL TYPE [2] | DESCRIPTION [3] | ALV/ANI PIN [4] | ALX PIN [4] |
|-----------------|-----------------|-----------------|-----------------|-------------|
| SPI4_D0 | IO | SPI Data 0 | A16 | A9 |
| SPI4_D1 | IO | SPI Data 1 | D16 | C11 |

(1) The SPI4_CS3 signal is not supported by the ALX packaged device. See [AM243x_ALX Package - Unsupported Interfaces and Signals](#) for additional details.

MCU Domain Instances**Table 5-58. MCU_MCSPi0 Signal Descriptions**

| SIGNAL NAME [1] | SIGNAL TYPE [2] | DESCRIPTION [3] | ALV/ANI PIN [4] | ALX PIN [4] |
|-----------------|-----------------|-------------------|-----------------|-------------|
| MCU_SPI0_CLK | IO | SPI Clock | E6 | |
| MCU_SPI0_CS0 | IO | SPI Chip Select 0 | D6 | |
| MCU_SPI0_CS1 | IO | SPI Chip Select 1 | C6 | |
| MCU_SPI0_CS2 | IO | SPI Chip Select 2 | D8 | D4 |
| MCU_SPI0_CS3 | IO | SPI Chip Select 3 | B8 | |
| MCU_SPI0_D0 | IO | SPI Data 0 | E7 | |
| MCU_SPI0_D1 | IO | SPI Data 1 | B6 | |

Table 5-59. MCU_MCSPi1 Signal Descriptions

| SIGNAL NAME [1] | SIGNAL TYPE [2] | DESCRIPTION [3] | ALV/ANI PIN [4] | ALX PIN [4] |
|-----------------|-----------------|-------------------|-----------------|-------------|
| MCU_SPI1_CLK | IO | SPI Clock | D7 | |
| MCU_SPI1_CS0 | IO | SPI Chip Select 0 | A7 | |
| MCU_SPI1_CS1 | IO | SPI Chip Select 1 | B7 | |
| MCU_SPI1_CS2 | IO | SPI Chip Select 2 | E8 | C2 |
| MCU_SPI1_CS3 | IO | SPI Chip Select 3 | B9 | |
| MCU_SPI1_D0 | IO | SPI Data 0 | C7 | |
| MCU_SPI1_D1 | IO | SPI Data 1 | C8 | |

5.3.16 MMC**MAIN Domain Instances****Table 5-60. MMC0 Signal Descriptions**

| SIGNAL NAME [1] (2) | SIGNAL TYPE [2] | DESCRIPTION [3] | ALV/ANI PIN [4] | ALX PIN [4] |
|---------------------|-----------------|----------------------------------|-----------------|-------------|
| MMC0_CALPAD (1) | A | MMC/SD/SDIO Calibration Resistor | F18 | |
| MMC0_CLK | IO | MMC/SD/SDIO Clock | G18 | |
| MMC0_CMD | IO | MMC/SD/SDIO Command | J21 | |
| MMC0_DS | IO | MMC Data Strobe | G19 | |
| MMC0_DAT0 | IO | MMC/SD/SDIO Data 0 | K20 | |
| MMC0_DAT1 | IO | MMC/SD/SDIO Data 1 | J20 | |
| MMC0_DAT2 | IO | MMC/SD/SDIO Data 2 | J18 | |
| MMC0_DAT3 | IO | MMC/SD/SDIO Data 3 | J17 | |
| MMC0_DAT4 | IO | MMC/SD/SDIO Data 4 | H17 | |
| MMC0_DAT5 | IO | MMC/SD/SDIO Data 5 | H19 | |
| MMC0_DAT6 | IO | MMC/SD/SDIO Data 6 | H18 | |
| MMC0_DAT7 | IO | MMC/SD/SDIO Data 7 | G17 | |

(1) An external 10kΩ ±1% resistor must be connected between this pin and VSS. No external voltage should be applied to this pin.

(2) The MMC0 interface is not supported by the ALX packaged devices. See [AM243x_ALX Package - Unsupported Interfaces and Signals](#) for additional details.

Table 5-61. MMC1 Signal Descriptions

| SIGNAL NAME [1] | SIGNAL TYPE [2] | DESCRIPTION [3] | ALV/ANI PIN [4] | ALX PIN [4] |
|-----------------|-----------------|---------------------|-----------------|-------------|
| MMC1_CLK | IO | MMC/SD/SDIO Clock | L20 | J20 |
| MMC1_CMD | IO | MMC/SD/SDIO Command | J19 | J21 |
| MMC1_SDCD | I | SD Card Detect | D19 | B17 |
| MMC1_SDWP | I | SD Write Protect | C20 | C16 |
| MMC1_DAT0 | IO | MMC/SD/SDIO Data 0 | K21 | J18 |
| MMC1_DAT1 | IO | MMC/SD/SDIO Data 1 | L21 | J19 |
| MMC1_DAT2 | IO | MMC/SD/SDIO Data 2 | K19 | K20 |
| MMC1_DAT3 | IO | MMC/SD/SDIO Data 3 | K18 | K18 |

5.3.17 OSPI

MAIN Domain Instances

Table 5-62. OSPI0 Signal Descriptions

| SIGNAL NAME [1] | SIGNAL TYPE [2] | DESCRIPTION [3] | ALV/ANI PIN [4] | ALX PIN [4] |
|--|-----------------|--|-----------------|-------------|
| OSPI0_CLK | O | OSPI Clock Output | N20 | P20 |
| OSPI0_DQS | I | OSPI Data Strobe (DQS) or Loopback Clock Input | N19 | P17 |
| OSPI0_ECC_FAIL ⁽²⁾ | I | OSPI ECC Status | L17 | |
| OSPI0_LBCLKO | IO | OSPI Loopback Clock Output | N21 | M21 |
| OSPI0_CS _n 0 | O | OSPI Chip Select 0 (active low) | L19 | L20 |
| OSPI0_CS _n 1 | O | OSPI Chip Select 1 (active low) | L18 | M20 |
| OSPI0_CS _n 2 ⁽²⁾ | O | OSPI Chip Select 2 (active low) | K17 | |
| OSPI0_CS _n 3 ⁽²⁾ | O | OSPI Chip Select 3 (active low) | L17 | |
| OSPI0_D0 | IO | OSPI Data 0 | M19 | L19 |
| OSPI0_D1 | IO | OSPI Data 1 | M18 | N20 |
| OSPI0_D2 | IO | OSPI Data 2 | M20 | L21 |
| OSPI0_D3 | IO | OSPI Data 3 | M21 | N19 |
| OSPI0_D4 ⁽¹⁾ | IO | OSPI Data 4 | P21 | |
| OSPI0_D5 ⁽¹⁾ | IO | OSPI Data 5 | P20 | |
| OSPI0_D6 ⁽¹⁾ | IO | OSPI Data 6 | N18 | |
| OSPI0_D7 ⁽¹⁾ | IO | OSPI Data 7 | M17 | |
| OSPI0_RESET_OUT0 ⁽²⁾ | O | OSPI Reset Output | L17 | |
| OSPI0_RESET_OUT1 ⁽²⁾ | O | OSPI Reset Output | K17 | |

(1) This OSPI0 signal is not supported by the ALX packaged device. See [AM243x_ALX Package - Unsupported Interfaces and Signals](#) for additional details. The OSPI0 is limited to QSPI (4-bit) functionality for the ALX package.

(2) This OSPI0 signal is not supported by the ALX packaged device. See [AM243x_ALX Package - Unsupported Interfaces and Signals](#) for additional details.

5.3.18 Power Supply

Table 5-63. Power Supply Signal Descriptions

| SIGNAL NAME [1] | SIGNAL TYPE [2] | DESCRIPTION [3] | ALV/ANI PIN [4] | ALX PIN [4] |
|--------------------------------|-----------------|--|-----------------|-------------|
| CAP_VDDS0 ⁽¹⁾ | CAP | External capacitor connection for IO group 0 | H12 | D12 |
| CAP_VDDS1 ⁽¹⁾ | CAP | External capacitor connection for IO group 1 | T7 | N5 |
| CAP_VDDS2 ⁽¹⁾ | CAP | External capacitor connection for IO group 2 | R11 | U9 |
| CAP_VDDS3 ⁽¹⁾ | CAP | External capacitor connection for IO group 3 | N14 | R16 |
| CAP_VDDS4 ⁽¹⁾ | CAP | External capacitor connection for IO group 4 | M16 | N18 |
| CAP_VDDS5 ⁽¹⁾ | CAP | External capacitor connection for IO group 5 | L13 | M18 |
| CAP_VDDSHV_MMC1 ⁽²⁾ | CAP | External capacitor connection for SDIO_LDO | K15 | J17 |
| CAP_VDDS_MCU ⁽¹⁾ | CAP | External capacitor connection for IO MCU | H10 | D9 |
| VDDA_0P85_SERDES0 | PWR | SERDES0 0.85V analog supply | P12, P13 | |

Table 5-63. Power Supply Signal Descriptions (continued)

| SIGNAL NAME [1] | SIGNAL TYPE [2] | DESCRIPTION [3] | ALV/ANI PIN [4] | ALX PIN [4] |
|---------------------|-----------------|--|--|---|
| VDDA_0P85_SERDES0_C | PWR | SERDES0 clock 0.85V analog supply | P11 | |
| VDDA_0P85_USB0 | PWR | USB0 0.85V analog supply | T12 | V16 |
| VDDA_1P8_SERDES0 | PWR | SERDES0 1.8V analog supply | R14 | |
| VDDA_1P8_USB0 | PWR | USB0 1.8V analog supply | R15 | U15 |
| VDDA_3P3_SDIO | PWR | SDIO_LDO 3.3V analog supply | H15 | K15 |
| VDDA_3P3_USB0 | PWR | USB0 3.3V analog supply | R13 | U16 |
| VDDA_ADC | PWR | ADC0 analog supply | J13 | G17, H17 |
| VDDA_MCU | PWR | RCOSC, POR, POK, and MCU_PLL0 analog supply | K12 | H14 |
| VDDA_PLL0 | PWR | MAIN_PLL0, MAIN_PLL2, and MAIN_PLL14 analog supply | N12 | N12 |
| VDDA_PLL1 | PWR | MAIN_PLL8 and MAIN_PLL12 analog supply | H9 | G9 |
| VDDA_PLL2 | PWR | MAIN_PLL1 analog supply | J11 | G12 |
| VDDA_TEMP0 | PWR | TEMP0 analog supply | G11 | G11 |
| VDDA_TEMP1 | PWR | TEMP1 analog supply | L11 | M11 |
| VDDR_CORE | PWR | RAM supply | L10, M13 | G5, G6, J10, J12, P14, P8, R10 |
| VDDSHV0 | PWR | IO supply for IO group 0 | F11, G12, G14 | C13, D13, E14 |
| VDDSHV1 | PWR | IO supply for IO group 1 | M7, N6, P7 | L6, M6, P5, P6 |
| VDDSHV2 | PWR | IO supply for IO group 2 | R10, R8, T9 | T11, T8, U11, U7, U8 |
| VDDSHV3 | PWR | IO supply for IO group 3 | P14, P15 | R17, T17 |
| VDDSHV4 | PWR | IO supply for IO group 4 | M14, M15 | N16, N17 |
| VDDSHV5 | PWR | IO supply for IO group 5 | L14, L15 | L16, L17 |
| VDDSHV_MCU | PWR | IO supply for IO MCU | F9, G10, G8 | E7, E8, E9 |
| VDDS_DDR | PWR | DDR PHY IO supply | F7, G6, H7, J6, K7, L6 | |
| VDDS_DDR_C | PWR | DDR clock IO supply | J8 | |
| VDDS_MMC0 | PWR | MMC0 PHY IO supply | K14 | |
| VDDS_OSC | PWR | MCU_OSC0 supply | H13 | F18 |
| VDD_CORE | PWR | Core supply | J10, J12, K11, K9, L12, L8, M11, M9, N10, N8, P9 | F11, G10, H15, H8, J9, K11, K14, L13, L9, M14, M8, N10, N9, R12, R13, R9 |
| VDD_DLL_MMC0 | PWR | MMC0 PLL analog supply | H14 | |
| VDD_MMC0 | PWR | MMC0 PHY core supply | K13 | |
| VPP | PWR | eFuse ROM programming supply | G15 | E16 |
| VSS | GND | Ground | A1, A21, A5, A6, AA1, AA15, AA18, AA21, C10, C15, C3, D1, E11, E13, F10, F15, F8, G1, G16, G3, G7, G9, H11, H20, H21, H6, H8, J14, J7, J9, K6, K8, L1, L16, L3, L7, L9, M10, M12, M6, M8, N11, N13, N15, N7, N9, P1, P10, P18, P6, P8, R12, R7, R9, T10, T11, T15, T16, T8, U3, V17, W10, W18, Y14, Y17, Y19 | A1, A2, A20, A21, AA1, AA2, AA20, AA21, B1, B21, D10, D16, D17, E11, E13, E6, F17, F8, G16, H16, H6, H7, J11, J16, J5, J6, K16, K6, K7, K8, L10, L11, L12, M15, M16, M7, N11, N13, N6, P11, P15, P16, P7, R11, R6, T14, U6, Y1, Y21 |

- (1) This pin must always be connected via a 6.3V or greater, 0.8 μ F to 1.5 μ F capacitor to VSS if the respective VDDSHVx pin is ever operated at 3.3V. The capacitor selected must provide a capacitance within the defined range after it has been derated for DC-bias, operating temperature, and aging effects. There are three connection options if the respective VDDSHVx pin is only operated at 1.8V.

The pin can be connected to the same decoupling capacitor that is required for 3.3V operation, it can be left unconnected, or it can be connected to the same 1.8V power source as the respective VDDSHVx pin.

- (2) This pin must always be connected via a 6.3V or greater, 3.3µF ±20% capacitor to VSS when the SDIO_LDO is being used to source VDDSHV5. The capacitor selected must provide a capacitance within the defined range after it has been derated for DC-bias, operating temperature, and aging effects. Otherwise, this pin may be connected directly to VSS when the VDDA_3P3_SDIO pin is also connected directly to VSS.

5.3.19 PRU_ICSSG

MAIN Domain Instances

Table 5-64. PRU_ICSSG0 Signal Descriptions

| SIGNAL NAME [1] | SIGNAL TYPE [2] | DESCRIPTION [3] | ALV/ANI PIN [4] | ALX PIN [4] |
|------------------------------|-----------------|---|-----------------|-------------|
| PRG0_ECAP0_IN_APWM_OUT | IO | PRU_ICSSG0 Enhanced Capture (ECAP) Input or Auxiliary PWM (APWM) Output | R2, U5 | F3, M4 |
| PRG0_ECAP0_SYNC_IN | I | PRU_ICSSG0 ECAP Sync Input | P5, V5 | D1, T1 |
| PRG0_ECAP0_SYNC_OUT | O | PRU_ICSSG0 ECAP Sync Output | AA4, V5 | T1, T3 |
| PRG0_IEP0_EDIO_OUTVALID | O | PRU_ICSSG0 Industrial Ethernet (IEP0) Digital I/O Outvalid | C13 | B7 |
| PRG0_IEP0_EDC_LATCH_IN0 | I | PRU_ICSSG0 Industrial Ethernet (IEP0) Distributed Clock Latch Input 0 | V1 | K4 |
| PRG0_IEP0_EDC_LATCH_IN1 | I | PRU_ICSSG0 Industrial Ethernet (IEP0) Distributed Clock Latch Input 1 | T1 | E2 |
| PRG0_IEP0_EDC_SYNC_OUT0 | O | PRU_ICSSG0 Industrial Ethernet (IEP0) Distributed Clock Sync Output 0 | W1 | G2 |
| PRG0_IEP0_EDC_SYNC_OUT1 | O | PRU_ICSSG0 Industrial Ethernet (IEP0) Distributed Clock Sync Output 1 | U1 | E1 |
| PRG0_IEP0_EDIO_DATA_IN_OUT28 | IO | PRU_ICSSG0 Industrial Ethernet Digital I/O Data Input/Output | W6 | Y3 |
| PRG0_IEP0_EDIO_DATA_IN_OUT29 | IO | PRU_ICSSG0 Industrial Ethernet Digital I/O Data Input/Output | AA5 | U1 |
| PRG0_IEP0_EDIO_DATA_IN_OUT30 | IO | PRU_ICSSG0 Industrial Ethernet (IEP0) Digital I/O Data Input/Output | Y5 | R2 |
| PRG0_IEP0_EDIO_DATA_IN_OUT31 | IO | PRU_ICSSG0 Industrial Ethernet Digital I/O Data Input/Output | V6 | U2 |
| PRG0_IEP1_EDC_LATCH_IN0 | I | PRU_ICSSG0 Industrial Ethernet (IEP1) Distributed Clock Latch Input 0 | P5 | D1 |
| PRG0_IEP1_EDC_LATCH_IN1 | I | PRU_ICSSG0 Industrial Ethernet (IEP1) Distributed Clock Latch Input 1 | W5 | T5 |
| PRG0_IEP1_EDC_SYNC_OUT0 | O | PRU_ICSSG0 Industrial Ethernet (IEP1) Distributed Clock Sync Output 0 | R2 | F3 |
| PRG0_IEP1_EDC_SYNC_OUT1 | O | PRU_ICSSG0 Industrial Ethernet (IEP1) Distributed Clock Sync Output 1 | V5 | T1 |
| PRG0_MDIO0_MDC | O | PRU_ICSSG0 MDIO Clock | P3 | D2 |
| PRG0_MDIO0_MDIO | IO | PRU_ICSSG0 MDIO0 Data | P2 | E4 |
| PRG0_PRU0_GPI0 | I | PRU_ICSSG0 PRU Data Input | Y1 | J3 |
| PRG0_PRU0_GPI1 | I | PRU_ICSSG0 PRU Data Input | R4 | J4 |
| PRG0_PRU0_GPI2 | I | PRU_ICSSG0 PRU Data Input | U2 | G1 |
| PRG0_PRU0_GPI3 | I | PRU_ICSSG0 PRU Data Input | V2 | H1 |
| PRG0_PRU0_GPI4 | I | PRU_ICSSG0 PRU Data Input | AA2 | K2 |
| PRG0_PRU0_GPI5 | I | PRU_ICSSG0 PRU Data Input | R3 | F2 |
| PRG0_PRU0_GPI6 | I | PRU_ICSSG0 PRU Data Input | T3 | H2 |
| PRG0_PRU0_GPI7 | I | PRU_ICSSG0 PRU Data Input | T1 | E2 |
| PRG0_PRU0_GPI8 | I | PRU_ICSSG0 PRU Data Input | T2 | H5 |
| PRG0_PRU0_GPI9 | I | PRU_ICSSG0 PRU Data Input | W6 | Y3 |
| PRG0_PRU0_GPI10 | I | PRU_ICSSG0 PRU Data Input | AA5 | U1 |
| PRG0_PRU0_GPI11 | I | PRU_ICSSG0 PRU Data Input | Y3 | L1 |
| PRG0_PRU0_GPI12 | I | PRU_ICSSG0 PRU Data Input | AA3 | K1 |
| PRG0_PRU0_GPI13 | I | PRU_ICSSG0 PRU Data Input | R6 | N1 |
| PRG0_PRU0_GPI14 | I | PRU_ICSSG0 PRU Data Input | V4 | N2 |
| PRG0_PRU0_GPI15 | I | PRU_ICSSG0 PRU Data Input | T5 | N4 |
| PRG0_PRU0_GPI16 | I | PRU_ICSSG0 PRU Data Input | U4 | N3 |

Table 5-64. PRU_ICSSG0 Signal Descriptions (continued)

| SIGNAL NAME [1] | SIGNAL TYPE [2] | DESCRIPTION [3] | ALV/ANI PIN [4] | ALX PIN [4] |
|-----------------|-----------------|----------------------------|-----------------|-------------|
| PRG0_PRU0_GPI17 | I | PRU_ICSSG0 PRU Data Input | U1 | E1 |
| PRG0_PRU0_GPI18 | I | PRU_ICSSG0 PRU Data Input | V1 | K4 |
| PRG0_PRU0_GPI19 | I | PRU_ICSSG0 PRU Data Input | W1 | G2 |
| PRG0_PRU0_GPO0 | IO | PRU_ICSSG0 PRU Data Output | Y1 | J3 |
| PRG0_PRU0_GPO1 | IO | PRU_ICSSG0 PRU Data Output | R4 | J4 |
| PRG0_PRU0_GPO2 | IO | PRU_ICSSG0 PRU Data Output | U2 | G1 |
| PRG0_PRU0_GPO3 | IO | PRU_ICSSG0 PRU Data Output | V2 | H1 |
| PRG0_PRU0_GPO4 | IO | PRU_ICSSG0 PRU Data Output | AA2 | K2 |
| PRG0_PRU0_GPO5 | IO | PRU_ICSSG0 PRU Data Output | R3 | F2 |
| PRG0_PRU0_GPO6 | IO | PRU_ICSSG0 PRU Data Output | T3 | H2 |
| PRG0_PRU0_GPO7 | IO | PRU_ICSSG0 PRU Data Output | T1 | E2 |
| PRG0_PRU0_GPO8 | IO | PRU_ICSSG0 PRU Data Output | T2 | H5 |
| PRG0_PRU0_GPO9 | IO | PRU_ICSSG0 PRU Data Output | W6 | Y3 |
| PRG0_PRU0_GPO10 | IO | PRU_ICSSG0 PRU Data Output | AA5 | U1 |
| PRG0_PRU0_GPO11 | IO | PRU_ICSSG0 PRU Data Output | Y3 | L1 |
| PRG0_PRU0_GPO12 | IO | PRU_ICSSG0 PRU Data Output | AA3 | K1 |
| PRG0_PRU0_GPO13 | IO | PRU_ICSSG0 PRU Data Output | R6 | N1 |
| PRG0_PRU0_GPO14 | IO | PRU_ICSSG0 PRU Data Output | V4 | N2 |
| PRG0_PRU0_GPO15 | IO | PRU_ICSSG0 PRU Data Output | T5 | N4 |
| PRG0_PRU0_GPO16 | IO | PRU_ICSSG0 PRU Data Output | U4 | N3 |
| PRG0_PRU0_GPO17 | IO | PRU_ICSSG0 PRU Data Output | U1 | E1 |
| PRG0_PRU0_GPO18 | IO | PRU_ICSSG0 PRU Data Output | V1 | K4 |
| PRG0_PRU0_GPO19 | IO | PRU_ICSSG0 PRU Data Output | W1 | G2 |
| PRG0_PRU1_GPI0 | I | PRU_ICSSG0 PRU Data Input | Y2 | L5 |
| PRG0_PRU1_GPI1 | I | PRU_ICSSG0 PRU Data Input | W2 | J2 |
| PRG0_PRU1_GPI2 | I | PRU_ICSSG0 PRU Data Input | V3 | M2 |
| PRG0_PRU1_GPI3 | I | PRU_ICSSG0 PRU Data Input | T4 | L2 |
| PRG0_PRU1_GPI4 | I | PRU_ICSSG0 PRU Data Input | W3 | L3 |
| PRG0_PRU1_GPI5 | I | PRU_ICSSG0 PRU Data Input | P4 | E3 |
| PRG0_PRU1_GPI6 | I | PRU_ICSSG0 PRU Data Input | R5 | F5 |
| PRG0_PRU1_GPI7 | I | PRU_ICSSG0 PRU Data Input | W5 | T5 |
| PRG0_PRU1_GPI8 | I | PRU_ICSSG0 PRU Data Input | R1 | F4 |
| PRG0_PRU1_GPI9 | I | PRU_ICSSG0 PRU Data Input | Y5 | R2 |
| PRG0_PRU1_GPI10 | I | PRU_ICSSG0 PRU Data Input | V6 | U2 |
| PRG0_PRU1_GPI11 | I | PRU_ICSSG0 PRU Data Input | W4 | P1 |
| PRG0_PRU1_GPI12 | I | PRU_ICSSG0 PRU Data Input | Y4 | P2 |
| PRG0_PRU1_GPI13 | I | PRU_ICSSG0 PRU Data Input | T6 | T4 |
| PRG0_PRU1_GPI14 | I | PRU_ICSSG0 PRU Data Input | U6 | R5 |
| PRG0_PRU1_GPI15 | I | PRU_ICSSG0 PRU Data Input | U5 | M4 |
| PRG0_PRU1_GPI16 | I | PRU_ICSSG0 PRU Data Input | AA4 | T3 |
| PRG0_PRU1_GPI17 | I | PRU_ICSSG0 PRU Data Input | V5 | T1 |
| PRG0_PRU1_GPI18 | I | PRU_ICSSG0 PRU Data Input | P5 | D1 |
| PRG0_PRU1_GPI19 | I | PRU_ICSSG0 PRU Data Input | R2 | F3 |
| PRG0_PRU1_GPO0 | IO | PRU_ICSSG0 PRU Data Output | Y2 | L5 |
| PRG0_PRU1_GPO1 | IO | PRU_ICSSG0 PRU Data Output | W2 | J2 |
| PRG0_PRU1_GPO2 | IO | PRU_ICSSG0 PRU Data Output | V3 | M2 |
| PRG0_PRU1_GPO3 | IO | PRU_ICSSG0 PRU Data Output | T4 | L2 |
| PRG0_PRU1_GPO4 | IO | PRU_ICSSG0 PRU Data Output | W3 | L3 |
| PRG0_PRU1_GPO5 | IO | PRU_ICSSG0 PRU Data Output | P4 | E3 |

Table 5-64. PRU_ICSSG0 Signal Descriptions (continued)

| SIGNAL NAME [1] | SIGNAL TYPE [2] | DESCRIPTION [3] | ALV/ANI PIN [4] | ALX PIN [4] |
|--------------------|-----------------|----------------------------------|-----------------|-------------|
| PRG0_PRU1_GPO6 | IO | PRU_ICSSG0 PRU Data Output | R5 | F5 |
| PRG0_PRU1_GPO7 | IO | PRU_ICSSG0 PRU Data Output | W5 | T5 |
| PRG0_PRU1_GPO8 | IO | PRU_ICSSG0 PRU Data Output | R1 | F4 |
| PRG0_PRU1_GPO9 | IO | PRU_ICSSG0 PRU Data Output | Y5 | R2 |
| PRG0_PRU1_GPO10 | IO | PRU_ICSSG0 PRU Data Output | V6 | U2 |
| PRG0_PRU1_GPO11 | IO | PRU_ICSSG0 PRU Data Output | W4 | P1 |
| PRG0_PRU1_GPO12 | IO | PRU_ICSSG0 PRU Data Output | Y4 | P2 |
| PRG0_PRU1_GPO13 | IO | PRU_ICSSG0 PRU Data Output | T6 | T4 |
| PRG0_PRU1_GPO14 | IO | PRU_ICSSG0 PRU Data Output | U6 | R5 |
| PRG0_PRU1_GPO15 | IO | PRU_ICSSG0 PRU Data Output | U5 | M4 |
| PRG0_PRU1_GPO16 | IO | PRU_ICSSG0 PRU Data Output | AA4 | T3 |
| PRG0_PRU1_GPO17 | IO | PRU_ICSSG0 PRU Data Output | V5 | T1 |
| PRG0_PRU1_GPO18 | IO | PRU_ICSSG0 PRU Data Output | P5 | D1 |
| PRG0_PRU1_GPO19 | IO | PRU_ICSSG0 PRU Data Output | R2 | F3 |
| PRG0_PWM0_TZ_IN | I | PRU_ICSSG0 PWM Trip Zone Input | V1 | K4 |
| PRG0_PWM0_TZ_OUT | O | PRU_ICSSG0 PWM Trip Zone Output | W1 | G2 |
| PRG0_PWM1_TZ_IN | I | PRU_ICSSG0 PWM Trip Zone Input | P5 | D1 |
| PRG0_PWM1_TZ_OUT | O | PRU_ICSSG0 PWM Trip Zone Output | R2 | F3 |
| PRG0_PWM2_TZ_IN | I | PRU_ICSSG0 PWM Trip Zone Input | T18, V6 | T19, U2 |
| PRG0_PWM2_TZ_OUT | O | PRU_ICSSG0 PWM Trip Zone Output | R1, U21 | F4, R20 |
| PRG0_PWM3_TZ_IN | I | PRU_ICSSG0 PWM Trip Zone Input | P16, W6 | Y3 |
| PRG0_PWM3_TZ_OUT | O | PRU_ICSSG0 PWM Trip Zone Output | R17, Y3 | L1 |
| PRG0_PWM0_A0 | IO | PRU_ICSSG0 PWM Output A | AA3 | K1 |
| PRG0_PWM0_A1 | IO | PRU_ICSSG0 PWM Output A | V4 | N2 |
| PRG0_PWM0_A2 | IO | PRU_ICSSG0 PWM Output A | U4 | N3 |
| PRG0_PWM0_B0 | IO | PRU_ICSSG0 PWM Output B | R6 | N1 |
| PRG0_PWM0_B1 | IO | PRU_ICSSG0 PWM Output B | T5 | N4 |
| PRG0_PWM0_B2 | IO | PRU_ICSSG0 PWM Output B2 | U1 | E1 |
| PRG0_PWM1_A0 | IO | PRU_ICSSG0 PWM Output A | Y4 | P2 |
| PRG0_PWM1_A1 | IO | PRU_ICSSG0 PWM Output A | U6 | R5 |
| PRG0_PWM1_A2 | IO | PRU_ICSSG0 PWM Output A | AA4 | T3 |
| PRG0_PWM1_B0 | IO | PRU_ICSSG0 PWM Output B | T6 | T4 |
| PRG0_PWM1_B1 | IO | PRU_ICSSG0 PWM Output B | U5 | M4 |
| PRG0_PWM1_B2 | IO | PRU_ICSSG0 PWM Output B2 | V5 | T1 |
| PRG0_PWM2_A0 | IO | PRU_ICSSG0 PWM Output A | U2, U20 | G1, V21 |
| PRG0_PWM2_A1 | IO | PRU_ICSSG0 PWM Output A | T2, U19 | H5, T20 |
| PRG0_PWM2_A2 | IO | PRU_ICSSG0 PWM Output A | V19, V3 | M2, U18 |
| PRG0_PWM2_B0 | IO | PRU_ICSSG0 PWM Output B | AA2, U18 | K2, U21 |
| PRG0_PWM2_B1 | IO | PRU_ICSSG0 PWM Output B | AA5, V20 | T18, U1 |
| PRG0_PWM2_B2 | IO | PRU_ICSSG0 PWM Output B | T17, W3 | L3, U20 |
| PRG0_PWM3_A0 | IO | PRU_ICSSG0 PWM Output A | V18, Y1 | J3, Y19 |
| PRG0_PWM3_A1 | IO | PRU_ICSSG0 PWM Output A | R18, T3 | H2 |
| PRG0_PWM3_A2 | IO | PRU_ICSSG0 PWM Output A | T19, V2 | H1, P21 |
| PRG0_PWM3_B0 | IO | PRU_ICSSG0 PWM Output B | R4, Y21 | J4, Y18 |
| PRG0_PWM3_B1 | IO | PRU_ICSSG0 PWM Output B | T1, T21 | E2 |
| PRG0_PWM3_B2 | IO | PRU_ICSSG0 PWM Output B | R3, W19 | F2 |
| PRG0_RGMII1_RXC | I | PRU_ICSSG0 RGMII Receive Clock | T3 | H2 |
| PRG0_RGMII1_RX_CTL | I | PRU_ICSSG0 RGMII Receive Control | AA2 | K2 |
| PRG0_RGMII1_TXC | IO | PRU_ICSSG0 RGMII Transmit Clock | U4 | N3 |

Table 5-64. PRU_ICSSG0 Signal Descriptions (continued)

| SIGNAL NAME [1] | SIGNAL TYPE [2] | DESCRIPTION [3] | ALV/ANI PIN [4] | ALX PIN [4] |
|--------------------|-----------------|--|-----------------|-------------|
| PRG0_RGMII1_TX_CTL | O | PRU_ICSSG0 RGMII Transmit Control | T5 | N4 |
| PRG0_RGMII2_RXC | I | PRU_ICSSG0 RGMII Receive Clock | R5 | F5 |
| PRG0_RGMII2_RX_CTL | I | PRU_ICSSG0 RGMII Receive Control | W3 | L3 |
| PRG0_RGMII2_TXC | IO | PRU_ICSSG0 RGMII Transmit Clock | AA4 | T3 |
| PRG0_RGMII2_TX_CTL | O | PRU_ICSSG0 RGMII Transmit Control | U5 | M4 |
| PRG0_RGMII1_RD0 | I | PRU_ICSSG0 RGMII Receive Data | Y1 | J3 |
| PRG0_RGMII1_RD1 | I | PRU_ICSSG0 RGMII Receive Data | R4 | J4 |
| PRG0_RGMII1_RD2 | I | PRU_ICSSG0 RGMII Receive Data | U2 | G1 |
| PRG0_RGMII1_RD3 | I | PRU_ICSSG0 RGMII Receive Data | V2 | H1 |
| PRG0_RGMII1_TD0 | O | PRU_ICSSG0 RGMII Transmit Data | Y3 | L1 |
| PRG0_RGMII1_TD1 | O | PRU_ICSSG0 RGMII Transmit Data | AA3 | K1 |
| PRG0_RGMII1_TD2 | O | PRU_ICSSG0 RGMII Transmit Data | R6 | N1 |
| PRG0_RGMII1_TD3 | O | PRU_ICSSG0 RGMII Transmit Data | V4 | N2 |
| PRG0_RGMII2_RD0 | I | PRU_ICSSG0 RGMII Receive Data | Y2 | L5 |
| PRG0_RGMII2_RD1 | I | PRU_ICSSG0 RGMII Receive Data | W2 | J2 |
| PRG0_RGMII2_RD2 | I | PRU_ICSSG0 RGMII Receive Data | V3 | M2 |
| PRG0_RGMII2_RD3 | I | PRU_ICSSG0 RGMII Receive Data | T4 | L2 |
| PRG0_RGMII2_TD0 | O | PRU_ICSSG0 RGMII Transmit Data | W4 | P1 |
| PRG0_RGMII2_TD1 | O | PRU_ICSSG0 RGMII Transmit Data | Y4 | P2 |
| PRG0_RGMII2_TD2 | O | PRU_ICSSG0 RGMII Transmit Data | T6 | T4 |
| PRG0_RGMII2_TD3 | O | PRU_ICSSG0 RGMII Transmit Data | U6 | R5 |
| PRG0_UART0_CTSn | I | PRU_ICSSG0 UART Clear to Send (active low) | W6 | Y3 |
| PRG0_UART0_RTSn | O | PRU_ICSSG0 UART Request to Send (active low) | AA5 | U1 |
| PRG0_UART0_RXD | I | PRU_ICSSG0 UART Receive Data | Y5 | R2 |
| PRG0_UART0_TXD | O | PRU_ICSSG0 UART Transmit Data | V6 | U2 |

Table 5-65. PRU_ICSSG1 Signal Descriptions

| SIGNAL NAME [1] | SIGNAL TYPE [2] | DESCRIPTION [3] | ALV/ANI PIN [4] | ALX PIN [4] |
|--|-----------------|---|-----------------|-------------|
| PRG1_ECAPH0_IN_APWM_OUT | IO | PRU_ICSSG1 Enhanced Capture (ECAP) Input or Auxiliary PWM (APWM) Output | V12 | AA13 |
| PRG1_ECAPH0_SYNC_IN | I | PRU_ICSSG1 ECAP Sync Input | Y13 | Y15 |
| PRG1_ECAPH0_SYNC_OUT | O | PRU_ICSSG1 ECAP Sync Output | AA14 | AA14 |
| PRG1_IEP0_EDIO_OUTVALID ⁽¹⁾ | O | PRU_ICSSG1 Industrial Ethernet Digital I/O Outvalid | D14 | |
| PRG1_IEP0_EDC_LATCH_IN0 | I | PRU_ICSSG1 Industrial Ethernet Distributed Clock Latch Input | V7 | Y4 |
| PRG1_IEP0_EDC_LATCH_IN1 | I | PRU_ICSSG1 Industrial Ethernet Distributed Clock Latch Input | U13 | V13 |
| PRG1_IEP0_EDC_SYNC_OUT0 | O | PRU_ICSSG1 Industrial Ethernet Distributed Clock Sync Output | W7 | U3 |
| PRG1_IEP0_EDC_SYNC_OUT1 | O | PRU_ICSSG1 Industrial Ethernet Distributed Clock Sync Output | U7 | T2 |
| PRG1_IEP0_EDIO_DATA_IN_OUT28 | IO | PRU_ICSSG1 Industrial Ethernet Digital I/O Data Input/Output | U15 | W16 |
| PRG1_IEP0_EDIO_DATA_IN_OUT29 | IO | PRU_ICSSG1 Industrial Ethernet Digital I/O Data Input/Output | U14 | W13 |
| PRG1_IEP0_EDIO_DATA_IN_OUT30 | IO | PRU_ICSSG1 Industrial Ethernet Digital I/O Data Input/Output | V14 | Y16 |
| PRG1_IEP0_EDIO_DATA_IN_OUT31 | IO | PRU_ICSSG1 Industrial Ethernet Digital I/O Data Input/Output | W14 | U13 |
| PRG1_IEP1_EDC_LATCH_IN0 | I | PRU_ICSSG1 Industrial Ethernet Distributed Clock Latch Input | Y13 | Y15 |
| PRG1_IEP1_EDC_LATCH_IN1 | I | PRU_ICSSG1 Industrial Ethernet Distributed Clock Latch Input | V15 | Y14 |
| PRG1_IEP1_EDC_SYNC_OUT0 | O | PRU_ICSSG1 Industrial Ethernet Distributed Clock Sync Output | V12 | AA13 |

Table 5-65. PRU_ICSSG1 Signal Descriptions (continued)

| SIGNAL NAME [1] | SIGNAL TYPE [2] | DESCRIPTION [3] | ALV/ANI PIN [4] | ALX PIN [4] |
|-------------------------|-----------------|--|-----------------|-------------|
| PRG1_IEP1_EDC_SYNC_OUT1 | O | PRU_ICSSG1 Industrial Ethernet Distributed Clock Sync Output | AA14 | AA14 |
| PRG1_MDIO0_MDC | O | PRU_ICSSG1 MDIO Clock | Y6 | W1 |
| PRG1_MDIO0_MDIO | IO | PRU_ICSSG1 MDIO Data | AA6 | V2 |
| PRG1_PRU0_GPI0 | I | PRU_ICSSG1 PRU Data Input | Y7 | V4 |
| PRG1_PRU0_GPI1 | I | PRU_ICSSG1 PRU Data Input | U8 | W5 |
| PRG1_PRU0_GPI2 | I | PRU_ICSSG1 PRU Data Input | W8 | AA4 |
| PRG1_PRU0_GPI3 | I | PRU_ICSSG1 PRU Data Input | V8 | Y5 |
| PRG1_PRU0_GPI4 | I | PRU_ICSSG1 PRU Data Input | Y8 | AA5 |
| PRG1_PRU0_GPI5 | I | PRU_ICSSG1 PRU Data Input | V13 | U14 |
| PRG1_PRU0_GPI6 | I | PRU_ICSSG1 PRU Data Input | AA7 | Y2 |
| PRG1_PRU0_GPI7 | I | PRU_ICSSG1 PRU Data Input | U13 | V13 |
| PRG1_PRU0_GPI8 | I | PRU_ICSSG1 PRU Data Input | W13 | Y13 |
| PRG1_PRU0_GPI9 | I | PRU_ICSSG1 PRU Data Input | U15 | W16 |
| PRG1_PRU0_GPI10 | I | PRU_ICSSG1 PRU Data Input | U14 | W13 |
| PRG1_PRU0_GPI11 | I | PRU_ICSSG1 PRU Data Input | AA8 | V5 |
| PRG1_PRU0_GPI12 | I | PRU_ICSSG1 PRU Data Input | U9 | W2 |
| PRG1_PRU0_GPI13 | I | PRU_ICSSG1 PRU Data Input | W9 | V6 |
| PRG1_PRU0_GPI14 | I | PRU_ICSSG1 PRU Data Input | AA9 | AA7 |
| PRG1_PRU0_GPI15 | I | PRU_ICSSG1 PRU Data Input | Y9 | Y7 |
| PRG1_PRU0_GPI16 | I | PRU_ICSSG1 PRU Data Input | V9 | W6 |
| PRG1_PRU0_GPI17 | I | PRU_ICSSG1 PRU Data Input | U7 | T2 |
| PRG1_PRU0_GPI18 | I | PRU_ICSSG1 PRU Data Input | V7 | Y4 |
| PRG1_PRU0_GPI19 | I | PRU_ICSSG1 PRU Data Input | W7 | U3 |
| PRG1_PRU0_GPO0 | IO | PRU_ICSSG1 PRU Data Output | Y7 | V4 |
| PRG1_PRU0_GPO1 | IO | PRU_ICSSG1 PRU Data Output | U8 | W5 |
| PRG1_PRU0_GPO2 | IO | PRU_ICSSG1 PRU Data Output | W8 | AA4 |
| PRG1_PRU0_GPO3 | IO | PRU_ICSSG1 PRU Data Output | V8 | Y5 |
| PRG1_PRU0_GPO4 | IO | PRU_ICSSG1 PRU Data Output | Y8 | AA5 |
| PRG1_PRU0_GPO5 | IO | PRU_ICSSG1 PRU Data Output | V13 | U14 |
| PRG1_PRU0_GPO6 | IO | PRU_ICSSG1 PRU Data Output | AA7 | Y2 |
| PRG1_PRU0_GPO7 | IO | PRU_ICSSG1 PRU Data Output | U13 | V13 |
| PRG1_PRU0_GPO8 | IO | PRU_ICSSG1 PRU Data Output | W13 | Y13 |
| PRG1_PRU0_GPO9 | IO | PRU_ICSSG1 PRU Data Output | U15 | W16 |
| PRG1_PRU0_GPO10 | IO | PRU_ICSSG1 PRU Data Output | U14 | W13 |
| PRG1_PRU0_GPO11 | IO | PRU_ICSSG1 PRU Data Output | AA8 | V5 |
| PRG1_PRU0_GPO12 | IO | PRU_ICSSG1 PRU Data Output | U9 | W2 |
| PRG1_PRU0_GPO13 | IO | PRU_ICSSG1 PRU Data Output | W9 | V6 |
| PRG1_PRU0_GPO14 | IO | PRU_ICSSG1 PRU Data Output | AA9 | AA7 |
| PRG1_PRU0_GPO15 | IO | PRU_ICSSG1 PRU Data Output | Y9 | Y7 |
| PRG1_PRU0_GPO16 | IO | PRU_ICSSG1 PRU Data Output | V9 | W6 |
| PRG1_PRU0_GPO17 | IO | PRU_ICSSG1 PRU Data Output | U7 | T2 |
| PRG1_PRU0_GPO18 | IO | PRU_ICSSG1 PRU Data Output | V7 | Y4 |
| PRG1_PRU0_GPO19 | IO | PRU_ICSSG1 PRU Data Output | W7 | U3 |
| PRG1_PRU1_GPI0 | I | PRU_ICSSG1 PRU Data Input | W11 | AA10 |
| PRG1_PRU1_GPI1 | I | PRU_ICSSG1 PRU Data Input | V11 | Y10 |
| PRG1_PRU1_GPI2 | I | PRU_ICSSG1 PRU Data Input | AA12 | Y11 |
| PRG1_PRU1_GPI3 | I | PRU_ICSSG1 PRU Data Input | Y12 | V12 |
| PRG1_PRU1_GPI4 | I | PRU_ICSSG1 PRU Data Input | W12 | Y12 |

Table 5-65. PRU_ICSSG1 Signal Descriptions (continued)

| SIGNAL NAME [1] | SIGNAL TYPE [2] | DESCRIPTION [3] | ALV/ANI PIN [4] | ALX PIN [4] |
|------------------|-----------------|---------------------------------|-----------------|-------------|
| PRG1_PRU1_GPI5 | I | PRU_ICSSG1 PRU Data Input | AA13 | AA11 |
| PRG1_PRU1_GPI6 | I | PRU_ICSSG1 PRU Data Input | U11 | V10 |
| PRG1_PRU1_GPI7 | I | PRU_ICSSG1 PRU Data Input | V15 | Y14 |
| PRG1_PRU1_GPI8 | I | PRU_ICSSG1 PRU Data Input | U12 | W11 |
| PRG1_PRU1_GPI9 | I | PRU_ICSSG1 PRU Data Input | V14 | Y16 |
| PRG1_PRU1_GPI10 | I | PRU_ICSSG1 PRU Data Input | W14 | U13 |
| PRG1_PRU1_GPI11 | I | PRU_ICSSG1 PRU Data Input | AA10 | Y6 |
| PRG1_PRU1_GPI12 | I | PRU_ICSSG1 PRU Data Input | V10 | AA8 |
| PRG1_PRU1_GPI13 | I | PRU_ICSSG1 PRU Data Input | U10 | Y9 |
| PRG1_PRU1_GPI14 | I | PRU_ICSSG1 PRU Data Input | AA11 | W9 |
| PRG1_PRU1_GPI15 | I | PRU_ICSSG1 PRU Data Input | Y11 | V9 |
| PRG1_PRU1_GPI16 | I | PRU_ICSSG1 PRU Data Input | Y10 | Y8 |
| PRG1_PRU1_GPI17 | I | PRU_ICSSG1 PRU Data Input | AA14 | AA14 |
| PRG1_PRU1_GPI18 | I | PRU_ICSSG1 PRU Data Input | Y13 | Y15 |
| PRG1_PRU1_GPI19 | I | PRU_ICSSG1 PRU Data Input | V12 | AA13 |
| PRG1_PRU1_GPO0 | IO | PRU_ICSSG1 PRU Data Output | W11 | AA10 |
| PRG1_PRU1_GPO1 | IO | PRU_ICSSG1 PRU Data Output | V11 | Y10 |
| PRG1_PRU1_GPO2 | IO | PRU_ICSSG1 PRU Data Output | AA12 | Y11 |
| PRG1_PRU1_GPO3 | IO | PRU_ICSSG1 PRU Data Output | Y12 | V12 |
| PRG1_PRU1_GPO4 | IO | PRU_ICSSG1 PRU Data Output | W12 | Y12 |
| PRG1_PRU1_GPO5 | IO | PRU_ICSSG1 PRU Data Output | AA13 | AA11 |
| PRG1_PRU1_GPO6 | IO | PRU_ICSSG1 PRU Data Output | U11 | V10 |
| PRG1_PRU1_GPO7 | IO | PRU_ICSSG1 PRU Data Output | V15 | Y14 |
| PRG1_PRU1_GPO8 | IO | PRU_ICSSG1 PRU Data Output | U12 | W11 |
| PRG1_PRU1_GPO9 | IO | PRU_ICSSG1 PRU Data Output | V14 | Y16 |
| PRG1_PRU1_GPO10 | IO | PRU_ICSSG1 PRU Data Output | W14 | U13 |
| PRG1_PRU1_GPO11 | IO | PRU_ICSSG1 PRU Data Output | AA10 | Y6 |
| PRG1_PRU1_GPO12 | IO | PRU_ICSSG1 PRU Data Output | V10 | AA8 |
| PRG1_PRU1_GPO13 | IO | PRU_ICSSG1 PRU Data Output | U10 | Y9 |
| PRG1_PRU1_GPO14 | IO | PRU_ICSSG1 PRU Data Output | AA11 | W9 |
| PRG1_PRU1_GPO15 | IO | PRU_ICSSG1 PRU Data Output | Y11 | V9 |
| PRG1_PRU1_GPO16 | IO | PRU_ICSSG1 PRU Data Output | Y10 | Y8 |
| PRG1_PRU1_GPO17 | IO | PRU_ICSSG1 PRU Data Output | AA14 | AA14 |
| PRG1_PRU1_GPO18 | IO | PRU_ICSSG1 PRU Data Output | Y13 | Y15 |
| PRG1_PRU1_GPO19 | IO | PRU_ICSSG1 PRU Data Output | V12 | AA13 |
| PRG1_PWM0_TZ_IN | I | PRU_ICSSG1 PWM Trip Zone Input | V7 | Y4 |
| PRG1_PWM0_TZ_OUT | O | PRU_ICSSG1 PWM Trip Zone Output | W7 | U3 |
| PRG1_PWM1_TZ_IN | I | PRU_ICSSG1 PWM Trip Zone Input | Y13 | Y15 |
| PRG1_PWM1_TZ_OUT | O | PRU_ICSSG1 PWM Trip Zone Output | V12 | AA13 |
| PRG1_PWM2_TZ_IN | I | PRU_ICSSG1 PWM Trip Zone Input | P19, W14 | U13 |
| PRG1_PWM2_TZ_OUT | O | PRU_ICSSG1 PWM Trip Zone Output | R20, U12 | W11 |
| PRG1_PWM3_TZ_IN | I | PRU_ICSSG1 PWM Trip Zone Input | U15 | W16 |
| PRG1_PWM3_TZ_OUT | O | PRU_ICSSG1 PWM Trip Zone Output | AA8 | V5 |
| PRG1_PWM0_A0 | IO | PRU_ICSSG1 PWM Output A | U9 | W2 |
| PRG1_PWM0_A1 | IO | PRU_ICSSG1 PWM Output A | AA9 | AA7 |
| PRG1_PWM0_A2 | IO | PRU_ICSSG1 PWM Output A | V9 | W6 |
| PRG1_PWM0_B0 | IO | PRU_ICSSG1 PWM Output B | W9 | V6 |
| PRG1_PWM0_B1 | IO | PRU_ICSSG1 PWM Output B | Y9 | Y7 |
| PRG1_PWM0_B2 | IO | PRU_ICSSG1 PWM Output B | U7 | T2 |

Table 5-65. PRU_ICSSG1 Signal Descriptions (continued)

| SIGNAL NAME [1] | SIGNAL TYPE [2] | DESCRIPTION [3] | ALV/ANI PIN [4] | ALX PIN [4] |
|--------------------|-----------------|--|-----------------|-------------|
| PRG1_PWM1_A0 | IO | PRU_ICSSG1 PWM Output A | V10 | AA8 |
| PRG1_PWM1_A1 | IO | PRU_ICSSG1 PWM Output A | AA11 | W9 |
| PRG1_PWM1_A2 | IO | PRU_ICSSG1 PWM Output A | Y10 | Y8 |
| PRG1_PWM1_B0 | IO | PRU_ICSSG1 PWM Output B | U10 | Y9 |
| PRG1_PWM1_B1 | IO | PRU_ICSSG1 PWM Output B | Y11 | V9 |
| PRG1_PWM1_B2 | IO | PRU_ICSSG1 PWM Output B | AA14 | AA14 |
| PRG1_PWM2_A0 | IO | PRU_ICSSG1 PWM Output A | N16, W8 | AA4 |
| PRG1_PWM2_A1 | IO | PRU_ICSSG1 PWM Output A | P17, W13 | Y13 |
| PRG1_PWM2_A2 | IO | PRU_ICSSG1 PWM Output A | AA12, V21 | U19, Y11 |
| PRG1_PWM2_B0 | IO | PRU_ICSSG1 PWM Output B | N17, Y8 | AA5 |
| PRG1_PWM2_B1 | IO | PRU_ICSSG1 PWM Output B | U14, Y18 | W13 |
| PRG1_PWM2_B2 | IO | PRU_ICSSG1 PWM Output B | R16, W12 | V20, Y12 |
| PRG1_PWM3_A0 | IO | PRU_ICSSG1 PWM Output A | Y7 | V4 |
| PRG1_PWM3_A1 | IO | PRU_ICSSG1 PWM Output A | AA7 | Y2 |
| PRG1_PWM3_A2 | IO | PRU_ICSSG1 PWM Output A | V8 | Y5 |
| PRG1_PWM3_B0 | IO | PRU_ICSSG1 PWM Output B | U8 | W5 |
| PRG1_PWM3_B1 | IO | PRU_ICSSG1 PWM Output B | U13 | V13 |
| PRG1_PWM3_B2 | IO | PRU_ICSSG1 PWM Output B | V13 | U14 |
| PRG1_RGMII1_RXC | I | PRU_ICSSG1 RGMII Receive Clock | AA7 | Y2 |
| PRG1_RGMII1_RX_CTL | I | PRU_ICSSG1 RGMII Receive Control | Y8 | AA5 |
| PRG1_RGMII1_TXC | IO | PRU_ICSSG1 RGMII Transmit Clock | V9 | W6 |
| PRG1_RGMII1_TX_CTL | O | PRU_ICSSG1 RGMII Transmit Control | Y9 | Y7 |
| PRG1_RGMII2_RXC | I | PRU_ICSSG1 RGMII Receive Clock | U11 | V10 |
| PRG1_RGMII2_RX_CTL | I | PRU_ICSSG1 RGMII Receive Control | W12 | Y12 |
| PRG1_RGMII2_TXC | IO | PRU_ICSSG1 RGMII Transmit Clock | Y10 | Y8 |
| PRG1_RGMII2_TX_CTL | O | PRU_ICSSG1 RGMII Transmit Control | Y11 | V9 |
| PRG1_RGMII1_RD0 | I | PRU_ICSSG1 RGMII Receive Data | Y7 | V4 |
| PRG1_RGMII1_RD1 | I | PRU_ICSSG1 RGMII Receive Data | U8 | W5 |
| PRG1_RGMII1_RD2 | I | PRU_ICSSG1 RGMII Receive Data | W8 | AA4 |
| PRG1_RGMII1_RD3 | I | PRU_ICSSG1 RGMII Receive Data | V8 | Y5 |
| PRG1_RGMII1_TD0 | O | PRU_ICSSG1 RGMII Transmit Data | AA8 | V5 |
| PRG1_RGMII1_TD1 | O | PRU_ICSSG1 RGMII Transmit Data | U9 | W2 |
| PRG1_RGMII1_TD2 | O | PRU_ICSSG1 RGMII Transmit Data | W9 | V6 |
| PRG1_RGMII1_TD3 | O | PRU_ICSSG1 RGMII Transmit Data | AA9 | AA7 |
| PRG1_RGMII2_RD0 | I | PRU_ICSSG1 RGMII Receive Data | W11 | AA10 |
| PRG1_RGMII2_RD1 | I | PRU_ICSSG1 RGMII Receive Data | V11 | Y10 |
| PRG1_RGMII2_RD2 | I | PRU_ICSSG1 RGMII Receive Data | AA12 | Y11 |
| PRG1_RGMII2_RD3 | I | PRU_ICSSG1 RGMII Receive Data | Y12 | V12 |
| PRG1_RGMII2_TD0 | O | PRU_ICSSG1 RGMII Transmit Data | AA10 | Y6 |
| PRG1_RGMII2_TD1 | O | PRU_ICSSG1 RGMII Transmit Data | V10 | AA8 |
| PRG1_RGMII2_TD2 | O | PRU_ICSSG1 RGMII Transmit Data | U10 | Y9 |
| PRG1_RGMII2_TD3 | O | PRU_ICSSG1 RGMII Transmit Data | AA11 | W9 |
| PRG1_UART0_CTSn | I | PRU_ICSSG1 UART Clear to Send (active low) | U15 | W16 |
| PRG1_UART0_RTSn | O | PRU_ICSSG1 UART Request to Send (active low) | U14 | W13 |
| PRG1_UART0_RXD | I | PRU_ICSSG1 UART Receive Data | V14 | Y16 |
| PRG1_UART0_TXD | O | PRU_ICSSG1 UART Transmit Data | W14 | U13 |

(1) The PRG1_IEP0_EDIO_OUTVALID signal is not supported by the ALX packaged device. See [AM243x_ALX Package - Unsupported Interfaces and Signals](#) for additional details.

5.3.20 Reserved and No Connect

Table 5-66. Reserved Signal Descriptions

| SIGNAL NAME [1] | SIGNAL TYPE [2] | DESCRIPTION [3] | ALV/ANI PIN [4] | ALX PIN [4] |
|-----------------|-----------------|------------------------------------|-----------------|-------------|
| RSVD0 | N/A | Reserved, must be left unconnected | H16 | H11 |
| RSVD1 | N/A | Reserved, must be left unconnected | D21 | J13 |
| RSVD2 | N/A | Reserved, must be left unconnected | G13 | |
| RSVD3 | N/A | Reserved, must be left unconnected | F17 | |
| RSVD4 | N/A | Reserved, must be left unconnected | W15 | |
| RSVD5 | N/A | Reserved, must be left unconnected | V16 | |
| RSVD6 | N/A | Reserved, must be left unconnected | K2 | |
| RSVD7 | N/A | Reserved, must be left unconnected | K1 | |
| RSVD8 | N/A | Reserved, must be left unconnected | F12 | |

5.3.21 SERDES

MAIN Domain Instances

Table 5-67. SERDES0 Signal Descriptions

| SIGNAL NAME [1] ⁽³⁾ ⁽²⁾ | SIGNAL TYPE [2] | DESCRIPTION [3] | ALV/ANI PIN [4] | ALX PIN [4] |
|---|-----------------|--|-----------------|-------------|
| PCIE0_CLKREQn | IO | PCIE Clock Request Signal | D16 | C11 |
| SERDES0_REXT ⁽¹⁾ | A | External SerDes PHY Calibration Resistor | T13 | |
| SERDES0_REFCLK0N | IO | SerDes PHY Reference Clock Input/Output (negative) | W16 | |
| SERDES0_REFCLK0P | IO | SerDes PHY Reference Clock Input/Output (positive) | W17 | |
| SERDES0_RX0_N | I | SerDes PHY Differential Receive Data (negative) | Y15 | |
| SERDES0_RX0_P | I | SerDes PHY Differential Receive Data (positive) | Y16 | |
| SERDES0_TX0_N | O | SerDes PHY Differential Transmit Data (negative) | AA16 | |
| SERDES0_TX0_P | O | SerDes PHY Differential Transmit Data (positive) | AA17 | |

(1) An external 3.01kΩ ±1% resistor must be connected between this pin and VSS. No external voltage should be applied to this pin.

(2) The functionality of these pins is controlled by the SERDES0_LN0_CTRL_LANE_FUNC_SEL register.

(3) The SERDES0 interface is not supported by the ALX packaged devices. See [AM243x_ALX Package - Unsupported Interfaces and Signals](#) for additional details.

5.3.22 System and Miscellaneous

5.3.22.1 Boot Mode Configuration

MAIN Domain Instances

Table 5-68. Sysboot Signal Descriptions

| SIGNAL NAME [1] | SIGNAL TYPE [2] | DESCRIPTION [3] | ALV/ANI PIN [4] | ALX PIN [4] |
|-----------------|-----------------|-----------------|-----------------|-------------|
| BOOTMODE00 | I | Bootmode pin 0 | T20 | R21 |
| BOOTMODE01 | I | Bootmode pin 1 | U21 | R20 |
| BOOTMODE02 | I | Bootmode pin 2 | T18 | T19 |
| BOOTMODE03 | I | Bootmode pin 3 | U20 | V21 |
| BOOTMODE04 | I | Bootmode pin 4 | U18 | U21 |
| BOOTMODE05 | I | Bootmode pin 5 | U19 | T20 |
| BOOTMODE06 | I | Bootmode pin 6 | V20 | T18 |
| BOOTMODE07 | I | Bootmode pin 7 | V21 | U19 |
| BOOTMODE08 | I | Bootmode pin 8 | V19 | U18 |
| BOOTMODE09 | I | Bootmode pin 9 | T17 | U20 |
| BOOTMODE10 | I | Bootmode pin 10 | R16 | V20 |
| BOOTMODE11 | I | Bootmode pin 11 | W20 | W20 |
| BOOTMODE12 | I | Bootmode pin 12 | W21 | Y20 |
| BOOTMODE13 | I | Bootmode pin 13 | V18 | Y19 |

Table 5-68. Sysboot Signal Descriptions (continued)

| SIGNAL NAME [1] | SIGNAL TYPE [2] | DESCRIPTION [3] | ALV/ANI PIN [4] | ALX PIN [4] |
|-----------------|-----------------|-----------------|-----------------|-------------|
| BOOTMODE14 | I | Bootmode pin 14 | Y21 | Y18 |
| BOOTMODE15 | I | Bootmode pin 15 | Y20 | AA19 |

5.3.22.2 Clocking

MCU Domain Instances

Table 5-69. MCU Clock Signal Descriptions

| SIGNAL NAME [1] | SIGNAL TYPE [2] | DESCRIPTION [3] | ALV/ANI PIN [4] | ALX PIN [4] |
|-----------------|-----------------|----------------------------------|-----------------|-------------|
| MCU_OSC0_XI | I | High frequency oscillator input | C21 | D20 |
| MCU_OSC0_XO | O | High frequency oscillator output | B20 | C21 |

5.3.22.3 SYSTEM

MAIN Domain Instances

Table 5-70. System Signal Descriptions

| SIGNAL NAME [1] | SIGNAL TYPE [2] | DESCRIPTION [3] | ALV/ANI PIN [4] | ALX PIN [4] |
|------------------------|-----------------|---|-----------------|-------------|
| CLKOUT0 | O | RMII Clock Output (50MHz). This pin is used for clock source to the external PHY and must be routed back to the RMII_REF_CLK pin for proper device operation. | A19, U13 | A18, V13 |
| EXTINTn ⁽¹⁾ | I | External Interrupt | C19 | |
| EXT_REFCLK1 | I | External clock input to Main domain | A19 | A18 |
| OBSClk0 | O | Observation clock output for test and debug purposes only | D17 | A15 |
| PORz_OUT | O | MAIN domain POR status output | E17 | D18 |
| RESETSTATz | O | MAIN domain warm reset status output | F16 | E19 |
| RESET_REQz | I | MAIN domain external warm reset request input | E18 | C17 |
| SYSClkOUT0 | O | SYSClk0 output from MAIN PLL controller (divided by 6) for test and debug purposes only | C17 | B14 |

(1) The EXTINTn signal is not supported by the ALX packaged device. See [AM243x_ALX Package - Unsupported Interfaces and Signals](#) for additional details.

MCU Domain Instances

Table 5-71. MCU System Signal Descriptions

| SIGNAL NAME [1] | SIGNAL TYPE [2] | DESCRIPTION [3] | ALV/ANI PIN [4] | ALX PIN [4] |
|--------------------------------|-----------------|---|-----------------|-------------|
| MCU_EXT_REFCLK0 ⁽²⁾ | I | External system clock input | B7 | |
| MCU_OBSClk0 | O | Observation clock output for test and debug purposes only | C6, E10 | B3 |
| MCU_PORz | I | MCU and Main domain cold reset | B21 | C20 |
| MCU_RESETSTATz | O | MCU domain warm reset status output | B13 | A6 |
| MCU_RESETz | I | MCU domain warm reset | B12 | A5 |
| MCU_SAFETY_ERRORn | IO | Error signal output from MCU domain ESM | A20 | B20 |
| MCU_SYSClkOUT0 ⁽¹⁾ | O | MCU domain system clock output for test and debug purposes only | C6 | |

- (1) The MCU_SYSClkOUT0 signal is not supported by the ALX packaged device. See [AM243x_ALX Package - Unsupported Interfaces and Signals](#) for additional details.
- (2) The MCU_EXT_REFCLK0 signal is not supported by the ALX packaged device. See [AM243x_ALX Package - Unsupported Interfaces and Signals](#) for additional details.

5.3.22.4 VMON

Table 5-72. VMON Signal Descriptions

| SIGNAL NAME [1] | SIGNAL TYPE [2] | DESCRIPTION [3] | ALV/ANI PIN [4] | ALX PIN [4] |
|-----------------|-----------------|---|-----------------|-------------|
| VMON_1P8_MCU | A | Voltage monitor input for 1.8V MCU power supply | K16 | |
| VMON_1P8_SOC | A | Voltage monitor input for 1.8V SoC power supply | E12 | F14 |
| VMON_3P3_MCU | A | Voltage monitor input for 3.3V MCU power supply | F13 | |
| VMON_3P3_SOC | A | Voltage monitor input for 3.3V SoC power supply | F14 | E15 |
| VMON_VSYS | A | Voltage monitor input, fixed 0.45V (+/-3%) threshold. Use with external precision voltage divider to monitor a higher voltage rail such as the PMIC input supply. | K10 | G13 |

5.3.23 TIMER

MAIN Domain Instances

Table 5-73. TIMER Signal Descriptions

| SIGNAL NAME [1] | SIGNAL TYPE [2] | DESCRIPTION [3] | ALV/ANI PIN [4] | ALX PIN [4] |
|-----------------|-----------------|--|-----------------|-------------|
| TIMER_IO0 | IO | Timer Inputs and Outputs (not tied to single timer instance) | C18, K18 | A17, K18 |
| TIMER_IO1 | IO | Timer Inputs and Outputs (not tied to single timer instance) | B19, K19 | B18, K20 |
| TIMER_IO2 | IO | Timer Inputs and Outputs (not tied to single timer instance) | A17, L21 | B13, J19 |
| TIMER_IO3 | IO | Timer Inputs and Outputs (not tied to single timer instance) | B17, K21 | A14, J18 |
| TIMER_IO4 | IO | Timer Inputs and Outputs (not tied to single timer instance) | C17, L20 | B14, J20 |
| TIMER_IO5 | IO | Timer Inputs and Outputs (not tied to single timer instance) | D17, J19 | A15, J21 |
| TIMER_IO6 | IO | Timer Inputs and Outputs (not tied to single timer instance) | B16, D19, T1 | B17, B9, E2 |
| TIMER_IO7 | IO | Timer Inputs and Outputs (not tied to single timer instance) | A16, C20, U7 | A9, C16, T2 |
| TIMER_IO8 | IO | Timer Inputs and Outputs (not tied to single timer instance) | P19, V7 | Y4 |
| TIMER_IO9 | IO | Timer Inputs and Outputs (not tied to single timer instance) | R21, W7 | U3 |
| TIMER_IO10 | IO | Timer Inputs and Outputs (not tied to single timer instance) | C13, U13 | B7, V13 |
| TIMER_IO11 | IO | Timer Inputs and Outputs (not tied to single timer instance) | D14, U1 | E1 |

MCU Domain Instances

Table 5-74. MCU_TIMER Signal Descriptions

| SIGNAL NAME [1] | SIGNAL TYPE [2] | DESCRIPTION [3] | ALV/ANI PIN [4] | ALX PIN [4] |
|------------------------------|-----------------|--|-----------------|-------------|
| MCU_TIMER_IO0 | IO | Timer Inputs and Outputs (not tied to single timer instance) | D8 | D4 |
| MCU_TIMER_IO1 | IO | Timer Inputs and Outputs (not tied to single timer instance) | E8 | C2 |
| MCU_TIMER_IO2 ⁽¹⁾ | IO | Timer Inputs and Outputs (not tied to single timer instance) | B8 | |
| MCU_TIMER_IO3 ⁽¹⁾ | IO | Timer Inputs and Outputs (not tied to single timer instance) | B9 | |

(1) This MCU_TIMER_IO signal is not supported by the ALX packaged device. See [AM243x_ALX Package - Unsupported Interfaces and Signals](#) for additional details.

5.3.24 UART

MAIN Domain Instances

Table 5-75. UART0 Signal Descriptions

| SIGNAL NAME [1] | SIGNAL TYPE [2] | DESCRIPTION [3] | ALV/ANI PIN [4] | ALX PIN [4] |
|-----------------|-----------------|---------------------------------------|-----------------|-------------|
| UART0_CTSn | I | UART Clear to Send (active low) | B16 | B9 |
| UART0_DCDn | I | UART Data Carrier Detect (active low) | C17 | B14 |
| UART0_DSRn | I | UART Data Set Ready (active low) | D17 | A15 |
| UART0_DTRn | O | UART Data Terminal Ready (active low) | A17 | B13 |
| UART0_RIn | I | UART Ring Indicator | B17 | A14 |
| UART0_RTSn | O | UART Request to Send (active low) | A16 | A9 |

Table 5-75. UART0 Signal Descriptions (continued)

| SIGNAL NAME [1] | SIGNAL TYPE [2] | DESCRIPTION [3] | ALV/ANI PIN [4] | ALX PIN [4] |
|-----------------|-----------------|--------------------|-----------------|-------------|
| UART0_RXD | I | UART Receive Data | D15 | B10 |
| UART0_TXD | O | UART Transmit Data | C16 | B11 |

Table 5-76. UART1 Signal Descriptions

| SIGNAL NAME [1] | SIGNAL TYPE [2] | DESCRIPTION [3] | ALV/ANI PIN [4] | ALX PIN [4] |
|-----------------|-----------------|-----------------------------------|-----------------|-------------|
| UART1_CTSn | I | UART Clear to Send (active low) | D16 | C11 |
| UART1_RTSn | O | UART Request to Send (active low) | E16 | A11 |
| UART1_RXD | I | UART Receive Data | E15 | B12 |
| UART1_TXD | O | UART Transmit Data | E14 | A12 |

Table 5-77. UART2 Signal Descriptions

| SIGNAL NAME [1] | SIGNAL TYPE [2] | DESCRIPTION [3] | ALV/ANI PIN [4] | ALX PIN [4] |
|-----------------|-----------------|-----------------------------------|-----------------------|----------------------|
| UART2_CTSn | I | UART Clear to Send (active low) | L20, V19, Y1 | J20, J3, U18 |
| UART2_RTSn | O | UART Request to Send (active low) | J19, T18, U2 | G1, J21, T19 |
| UART2_RXD | I | UART Receive Data | B16, K18, T20, V1, W6 | B9, K18, K4, R21, Y3 |
| UART2_TXD | O | UART Transmit Data | A16, K19, R4, U21 | A9, J4, K20, R20 |

Table 5-78. UART3 Signal Descriptions

| SIGNAL NAME [1] | SIGNAL TYPE [2] | DESCRIPTION [3] | ALV/ANI PIN [4] | ALX PIN [4] |
|-----------------|-----------------|-----------------------------------|------------------------|-----------------------|
| UART3_CTSn | I | UART Clear to Send (active low) | D19, T17, V2 | B17, H1, U20 |
| UART3_RTSn | O | UART Request to Send (active low) | C20, R3, U19 | C16, F2, T20 |
| UART3_RXD | I | UART Receive Data | AA5, D16, L21, U20, W1 | C11, G2, J19, U1, V21 |
| UART3_TXD | O | UART Transmit Data | AA2, E16, K21, U18 | A11, J18, K2, U21 |

Table 5-79. UART4 Signal Descriptions

| SIGNAL NAME [1] | SIGNAL TYPE [2] | DESCRIPTION [3] | ALV/ANI PIN [4] | ALX PIN [4] |
|-----------------|-----------------|-----------------------------------|---------------------------|---------------------------|
| UART4_CTSn | I | UART Clear to Send (active low) | R16, R5, T3, V1 | F5, H2, K4, V20 |
| UART4_RTSn | O | UART Request to Send (active low) | R1, R17, T2, W1 | F4, G2, H5 |
| UART4_RXD | I | UART Receive Data | A17, L20, V20, W4, Y3 | B13, J20, L1, P1, T18 |
| UART4_TXD | O | UART Transmit Data | B17, J19, T1, V21, W5, Y4 | A14, E2, J21, P2, T5, U19 |

Table 5-80. UART5 Signal Descriptions

| SIGNAL NAME [1] | SIGNAL TYPE [2] | DESCRIPTION [3] | ALV/ANI PIN [4] | ALX PIN [4] |
|-----------------|-----------------|-----------------------------------|-----------------------|------------------|
| UART5_CTSn | I | UART Clear to Send (active low) | W20, Y13, Y2 | L5, W20, Y15 |
| UART5_RTSn | O | UART Request to Send (active low) | T21, V12, V3 | AA13, M2 |
| UART5_RXD | I | UART Receive Data | C17, D19, P16, T6, Y5 | B14, B17, R2, T4 |
| UART5_TXD | O | UART Transmit Data | C20, D17, R18, W2 | A15, C16, J2 |

Table 5-81. UART6 Signal Descriptions

| SIGNAL NAME [1] | SIGNAL TYPE [2] | DESCRIPTION [3] | ALV/ANI PIN [4] | ALX PIN [4] |
|-----------------|-----------------|-----------------------------------|------------------|-----------------|
| UART6_CTSn | I | UART Clear to Send (active low) | T4, W21 | L2, Y20 |
| UART6_RTSn | O | UART Request to Send (active low) | P17, P4 | E3 |
| UART6_RXD | I | UART Receive Data | C13, U6, V6, Y21 | B7, R5, U2, Y18 |
| UART6_TXD | O | UART Transmit Data | D14, W3, Y20 | AA19, L3 |

MCU Domain Instances**Table 5-82. MCU_UART0 Signal Descriptions**

| SIGNAL NAME [1] | SIGNAL TYPE [2] | DESCRIPTION [3] | ALV/ANI PIN [4] | ALX PIN [4] |
|-----------------|-----------------|-----------------------------------|-----------------|-------------|
| MCU_UART0_CTSn | I | UART Clear to Send (active low) | D8 | D4 |
| MCU_UART0_RTSn | O | UART Request to Send (active low) | E8 | C2 |
| MCU_UART0_RXD | I | UART Receive Data | A9 | D6 |
| MCU_UART0_TXD | O | UART Transmit Data | A8 | B2 |

Table 5-83. MCU_UART1 Signal Descriptions

| SIGNAL NAME [1] ⁽¹⁾ | SIGNAL TYPE [2] | DESCRIPTION [3] | ALV/ANI PIN [4] | ALX PIN [4] |
|--------------------------------|-----------------|-----------------------------------|-----------------|-------------|
| MCU_UART1_CTSn | I | UART Clear to Send (active low) | B8 | |
| MCU_UART1_RTSn | O | UART Request to Send (active low) | B9 | |
| MCU_UART1_RXD | I | UART Receive Data | C9 | |
| MCU_UART1_TXD | O | UART Transmit Data | D9 | |

- (1) The MCU_UART1 interface is not supported by the ALX packaged devices. See [AM243x_ALX Package - Unsupported Interfaces and Signals](#) for additional details.

5.3.25 USB**MAIN Domain Instances****Table 5-84. USB0 Signal Descriptions**

| SIGNAL NAME [1] | SIGNAL TYPE [2] | DESCRIPTION [3] | ALV/ANI PIN [4] | ALX PIN [4] |
|----------------------------|-----------------|--|-----------------|-------------|
| USB0_DM | IO | USB 2.0 Differential Data (negative) | AA20 | AA17 |
| USB0_DP | IO | USB 2.0 Differential Data (positive) | AA19 | AA16 |
| USB0_DRVVBUS | O | USB VBUS control output (active high) | E19 | B19 |
| USB0_ID | A | USB 2.0 Dual-Role Device (DRD) role select | U16 | Y17 |
| USB0_RCALIB ⁽¹⁾ | A | Pin to connect to calibration resistor | U17 | W17 |
| USB0_VBUS ⁽²⁾ | A | USB Level-shifted VBUS Input | T14 | V18 |

- (1) An external 499Ω ±1% resistor must be connected between this pin and VSS. The maximum power dissipation for the resistor is 7.2mW. No external voltage should be applied to this pin.
- (2) An external resistor divider is required to limit the voltage applied to the device pin. For more information, see [Section 8.2.4, USB VBUS Design Guidelines](#).

5.4 Pin Connectivity Requirements

This section describes connectivity requirements for package balls that have specific connectivity requirements and unused package balls.

Note

All power balls must be supplied with the voltages specified in the *Recommended Operating Conditions* section, unless otherwise specified.

Note

For additional clarification, "leave unconnected" or "no connect" (NC) means **no** signal traces can be connected to these device ball numbers.

Table 5-85. Connectivity Requirements (ALV/ANI Package)

| BALL NUMBER | BALL NAME | CONNECTION REQUIREMENTS |
|--|--|--|
| A20 D11 | MCU_SAFETY_ERRORn TRSTn | Each of these balls must be connected to VSS through separate external pull resistors to ensure the inputs associated with these balls are held to a valid logic low level if a PCB signal trace is connected and not actively driven by an attached device. The internal pull-down can be used to hold a valid logic low level if no PCB signal trace is connected to the ball. |
| D10 E10 B12 E18 B11 C11 C12 | EMU0 EMU1 MCU_RESETz RESET_REQz TCK TDI TMS | Each of these balls must be connected to the corresponding power supply ⁽¹⁾ through separate external pull resistors to ensure the inputs associated with these balls are held to a valid logic high level if a PCB signal trace is connected and not actively driven by an attached device. The internal pull-up can be used to hold a valid logic high level if no PCB signal trace is connected to the ball. |
| A18 B18 E9 A10 | I2C0_SCL I2C0_SDA MCU_I2C0_SCL MCU_I2C0_SDA | Each of these balls must be connected to the corresponding power supply ⁽¹⁾ or VSS through separate external pull resistors to ensure the inputs associated with these balls are held to a valid logic high or low level as appropriate for the selected signal function. |
| T20 U21 T18 U20 U18 U19 V20 V21 V19 T17 R16 W20 W21 V18 Y21 Y20 | GPMC0_AD0 GPMC0_AD1 GPMC0_AD2 GPMC0_AD3 GPMC0_AD4 GPMC0_AD5 GPMC0_AD6 GPMC0_AD7 GPMC0_AD8 GPMC0_AD9 GPMC0_AD10 GPMC0_AD11 GPMC0_AD12 GPMC0_AD13 GPMC0_AD14 GPMC0_AD15 | Each of these balls must be connected to the corresponding power supply ⁽¹⁾ or VSS through separate external pull resistors to ensure the inputs associated with these balls are held to a valid logic high or low level as appropriate to select the desired device boot mode. |
| J13 G20 F20 E21, D20 G21 F21 F19 E20 J15 J16 | VDDA_ADC ADC0_AIN0 ADC0_AIN1 ADC0_AIN2 ADC0_AIN3 ADC0_AIN4 ADC0_AIN5 ADC0_AIN6 ADC0_AIN7 ADC0_REFP ADC0_REFN | If the entire ADC0 is not used, each of these balls must be connected directly to VSS. |

Table 5-85. Connectivity Requirements (ALV/ANI Package) (continued)

| BALL NUMBER | BALL NAME | CONNECTION REQUIREMENTS |
|--|--|---|
| G20 F20 E21 D20 G21 F21 F19 E20 | ADC0_AIN0 ADC0_AIN1 ADC0_AIN2 ADC0_AIN3 ADC0_AIN4 ADC0_AIN5 ADC0_AIN6 ADC0_AIN7 | Any unused ADC0_AIN[7:0] ball must be pulled to VSS through a resistor or connected directly to VSS when VDDA_ADC is connected to a power source. |
| F7 G6 H7 J6, K7 L6 J8 | VDDS_DDR VDDS_DDR VDDS_DDR VDDS_DDR VDDS_DDR VDDS_DDR VDDS_DDR_C | If DDRSS0 is not used, each of these balls must be connected directly to VSS. |

Table 5-85. Connectivity Requirements (ALV/ANI Package) (continued)

| BALL NUMBER | BALL NAME | CONNECTION REQUIREMENTS |
|--|---|---|
| H2 H1 J5 K5 F6 H4 D2 C5 E2 D4 D3 F2 J2 L5 J3 J4 K3 J1 M5 K4 G4 G5 G2 H3 H5 F1 E1 F4 F3 E3 E4 B2 M2 A3 A2 B5 A4 B3 C4 C2 B4 N5 L4 L2 M3 N4 N3 M4 N2 C1 B1 N1 M1 E5 F5 D5 | DDR0_ACT_n DDR0_ALERT_n DDR0_CAS_n DDR0_PAR DDR0_RAS_n DDR0_WE_n DDR0_A0 DDR0_A1 DDR0_A2 DDR0_A3 DDR0_A4 DDR0_A5 DDR0_A6 DDR0_A7 DDR0_A8 DDR0_A9 DDR0_A10 DDR0_A11 DDR0_A12 DDR0_A13 DDR0_BA0 DDR0_BA1 DDR0_BG0 DDR0_BG1 DDR0_CAL0 DDR0_CK0 DDR0_CK0_n DDR0_CKE0 DDR0_CKE1 DDR0_CS0_n DDR0_CS1_n DDR0_DM0 DDR0_DM1 DDR0_DQ0 DDR0_DQ1 DDR0_DQ2 DDR0_DQ3 DDR0_DQ4 DDR0_DQ5 DDR0_DQ6 DDR0_DQ7 DDR0_DQ8 DDR0_DQ9 DDR0_DQ10 DDR0_DQ11 DDR0_DQ12 DDR0_DQ13 DDR0_DQ14 DDR0_DQ15 DDR0_DQS0 DDR0_DQS0_n DDR0_DQS1 DDR0_DQS1_n DDR0_ODT0 DDR0_ODT1 DDR0_RESET0_n | <p>If DDRSS0 is not used, leave unconnected.</p> <p>Note: The DDR0 pins in this list can only be left unconnected when VDDSDDR and VDDSDDR_C are connected to VSS. The DDR0 pins must be connected as defined in the AM64x/AM243x DDR Board Design and Layout Guidelines, when VDDSDDR and VDDSDDR_C are connected to a power source.</p> |
| K13 H14 | VDD_MMC0 VDD_DLL_MMC0 | If MMC0 is not used, each of these balls must be connected to the same power source as VDD_CORE. |
| K14 | VDDSDDR_MMC0 | If MMC0 is not used, each of these balls must be connected to any 1.8V power source that does not violate device power supply sequencing requirements. |

Table 5-85. Connectivity Requirements (ALV/ANI Package) (continued)

| BALL NUMBER | BALL NAME | CONNECTION REQUIREMENTS |
|--|--|---|
| F18 G18 J21 G19 K20 J20 J18 J17 H17 H19 H18 G17 | MMC0_CALPAD MMC0_CLK MMC0_CMD MMC0_DS MMC0_DAT0 MMC0_DAT1 MMC0_DAT2 MMC0_DAT3 MMC0_DAT4 MMC0_DAT5 MMC0_DAT6 MMC0_DAT7 | If MMC0 is not used, each of these balls must be left unconnected. |
| H15 K15 | VDDA_3P3_SDIO CAP_VDDSHV_MMC1 | If SDIO_LDO is not used to power VDDSHV5, each of these balls must be connected directly to VSS. |
| P12 P13 P11 R14 | VDDA_0P85_SERDES0 VDDA_0P85_SERDES0 VDDA_0P85_SERDES0_C VDDA_1P8_SERDES0 | If SERDES0 is not used and the device boundary scan function is required, each of these balls must be connected to valid power sources. If SERDES0 is not used and the device boundary scan function is not required, each of these balls can alternatively be connected directly to VSS. |
| T13 W16 W17 Y15 Y16 AA16 AA17 | SERDES0_REXT SERDES0_REFCLK0N SERDES0_REFCLK0P SERDES0_RX0_N SERDES0_RX0_P SERDES0_TX0_N SERDES0_TX0_P | If SERDES0 is not used, leave unconnected. Note: The SERDES0_REXT pin can only be left unconnected when VDDA_0P85_SERDES0, VDDA_0P85_SERDES0_C, and VDDA_1P8_SERDES0 are connected to VSS. The SERDES0_REXT pin must be connected to VSS through the appropriate external resistor when VDDA_0P85_SERDES0, VDDA_0P85_SERDES0_C, and VDDA_1P8_SERDES0 are connected to power sources. |
| T12 R15 R13 | VDDA_0P85_USB0 VDDA_1P8_USB0 VDDA_3P3_USB0 | If USB0 is not used, each of these balls must be connected directly to VSS. |
| AA20 AA19 U16 U17 T14 | USB0_DM USB0_DP USB0_ID USB0_RCALIB USB0_VBUS | If USB0 is not used, leave unconnected. Note: The USB0_RCALIB pin can only be left unconnected when VDDA_0P85_USB0, VDDA_1P8_USB0, and VDDA_3P3_USB0 are connected to VSS. The USB0_RCALIB pin must be connected to VSS through the appropriate external resistor when VDDA_0P85_USB0, VDDA_1P8_USB0, and VDDA_3P3_USB0 are connected to power sources. |
| K10 | VMON_VSYS | If VMON_VSYS is not used, this ball must be connected directly to VSS. |
| E12 | VMON_1P8_SOC | If VMON_1P8_SOC is not used to monitor the SOC power rail, this ball must remain connected to a 1.8V power rail. |
| K16 F13 F14 | VMON_1P8_MCU VMON_3P3_MCU VMON_3P3_SOC | If VMON_1P8_MCU, VMON_3P3_MCU, and VMON_3P3_SOC are not used to monitor the MCU and SOC power rails, these balls must remain connected to the respective 1.8V and 3.3V power rails or connected directly to VSS. |

(1) To determine which power supply is associated with any IO, see the POWER column of the *Pin Attributes* table.

Table 5-86. Connectivity Requirements (ALX Package)

| BALL NUMBER | BALL NAME | CONNECTION REQUIREMENTS |
|---|--|---|
| B20 B6 | MCU_SAFETY_ERRORn TRSTn | Each of these balls must be connected to VSS through separate external pull resistors to ensure these balls are held to a valid logic low level if a PCB signal trace is connected and not actively driven by an attached device. The internal pull-down can be used to hold a valid logic low level if no PCB signal trace is connected to the ball. |
| C5 B3 A5 C17 C6 A3 B4 | EMU0 EMU1 MCU_RESETz RESET_REQz TCK TDI TMS | Each of these balls must be connected to the corresponding power supply ⁽¹⁾ through separate external pull resistors to ensure these balls are held to a valid logic high level if a PCB signal trace is connected and not actively driven by an attached device. The internal pull-up can be used to hold a valid logic high level if no PCB signal trace is connected to the ball. |
| B16 B15 | I2C0_SCL I2C0_SDA | Each of these balls must be connected to the corresponding power supply ⁽¹⁾ through separate external pull resistors to ensure these balls are held to a valid logic high level. |
| G17 H17 H21 F19 F21, F20 H20 E21 G20 E20 | VDDA_ADC VDDA_ADC ADC0_AIN0 ADC0_AIN1 ADC0_AIN2 ADC0_AIN3 ADC0_AIN4 ADC0_AIN5 ADC0_AIN6 ADC0_AIN7 | If the entire ADC0 is not used, each of these balls must be connected directly to VSS. |
| H21 F19 F21 F20 H20 E21 G20 E20 | ADC0_AIN0 ADC0_AIN1 ADC0_AIN2 ADC0_AIN3 ADC0_AIN4 ADC0_AIN5 ADC0_AIN6 ADC0_AIN7 | Any unused ADC0_AIN[7:0] ball must be pulled to VSS through a resistor or connected directly to VSS when VDDA_ADC is connected to a power source. |
| K15 J17 | VDDA_3P3_SDIO CAP_VDDSHV_MMC1 | If SDIO_LDO is not used to power VDDSHV5, each of these balls must be connected directly to VSS. |
| V16 U15 U16 | VDDA_0P85_USB0 VDDA_1P8_USB0 VDDA_3P3_USB0 | If USB0 is not used, each of these balls must be connected directly to VSS. |
| AA17 AA16 Y17 W17 V18 | USB0_DM USB0_DP USB0_ID USB0_RCALIB USB0_VBUS | If USB0 is not used, leave unconnected. Note: The USB0_RCALIB pin can only be left unconnected when VDDA_0P85_USB0, VDDA_1P8_USB0, and VDDA_3P3_USB0 are connected to VSS. The USB0_RCALIB pin must be connected to VSS through the appropriate external resistor when VDDA_0P85_USB0, VDDA_1P8_USB0, and VDDA_3P3_USB0 are connected to a power source. |
| G13 | VMON_VSYS | If VMON_VSYS is not used, this ball must be connected directly to VSS. |
| F14 | VMON_1P8_SOC | If VMON_1P8_SOC is not used to monitor the SOC power rail, this ball must remain connected to a 1.8V power rail. |
| E15 | VMON_3P3_SOC | If VMON_3P3_SOC is not used to monitor the SOC power rail, this ball must remain connected to a 3.3V power rail or connected directly to VSS. |

(1) To determine which power supply is associated with any IO, see POWER column of the *Pin Attributes* table.

Note

Internal pull resistors are weak and may not source enough current to maintain a valid logic level for some operating conditions. This can be the case when connected to components with leakage to the opposite logic level, or when external noise sources couple to signal traces attached to balls which are only pulled to a valid logic level by the internal resistor. Therefore, external pull resistors are recommended to hold a valid logic level on balls with external connections.

Many of the device IOs are turned off by default and external pull resistors may be required to hold inputs of any attached device in a valid logic state until software initializes the respective IOs. The state of configurable device IOs are defined in the BALL STATE DURING RESET RX/TX/PULL and BALL STATE AFTER RESET RX/TX/PULL columns of the *Pin Attributes* table. Any IO with its input buffer (RX) turned off is allowed to float without damaging the device. However, any IO with its input buffer (RX) turned on shall never be allowed to float to any potential between V_{ILSS} and V_{IHSS} . The input buffer can enter a high-current state which could damage the IO cell if allowed to float between these levels.

6 Specifications

6.1 Absolute Maximum Ratings

over operating junction temperature range (unless otherwise noted)^{(1) (2)}

| PARAMETER | | MIN | MAX | UNIT |
|---|--|------|---------------------|------|
| VDD_CORE | Core supply | -0.3 | 1.05 | V |
| VDDR_CORE | RAM supply | -0.3 | 1.05 | V |
| VDD_MMC0 | MMC0 PHY core supply | -0.3 | 1.05 | V |
| VDD_DLL_MMC0 | MMC0 PLL analog supply | -0.3 | 1.05 | V |
| VDDA_0P85_SERDES0 | SERDES0 0.85V analog supply | -0.3 | 1.05 | V |
| VDDA_0P85_SERDES0_C | SERDES0 clock 0.85V analog supply | -0.3 | 1.05 | V |
| VDDA_0P85_USB0 | USB0 0.85V analog supply | -0.3 | 1.05 | V |
| VDDS_DDR | DDR PHY IO supply | -0.3 | 1.57 | V |
| VDDS_DDR_C | DDR clock IO supply | -0.3 | 1.57 | V |
| VDDS_MMC0 | MMC0 PHY IO supply | -0.3 | 1.98 | V |
| VDDS_OSC | MCU_OSC0 supply | -0.3 | 1.98 | V |
| VDDA_MCU | RCOSC, POR, POK, and MCU_PLL0 analog supply | -0.3 | 1.98 | V |
| VDDA_ADC0 | ADC0 analog supply | -0.3 | 1.98 | V |
| VDDA_PLL0 | MAIN_PLL0, MAIN_PLL2, and MAIN_PLL14 analog supply | -0.3 | 1.98 | V |
| VDDA_PLL1 | MAIN_PLL8 and MAIN_PLL12 analog supply | -0.3 | 1.98 | V |
| VDDA_PLL2 | MAIN_PLL1 analog supply | -0.3 | 1.98 | V |
| VDDA_1P8_SERDES0 | SERDES0 1.8V analog supply | -0.3 | 1.98 | V |
| VDDA_1P8_USB0 | USB0 1.8V analog supply | -0.3 | 1.98 | V |
| VDDA_TEMP0 | TEMP0 analog supply | -0.3 | 1.98 | V |
| VDDA_TEMP1 | TEMP1 analog supply | -0.3 | 1.98 | V |
| VPP | eFuse ROM programming supply | -0.3 | 1.98 | V |
| VDDSHV_MCU | IO supply for IO MCU | -0.3 | 3.63 | V |
| VDDSHV0 | IO supply for IO group 0 | -0.3 | 3.63 | V |
| VDDSHV1 | IO supply for IO group 1 | -0.3 | 3.63 | V |
| VDDSHV2 | IO supply for IO group 2 | -0.3 | 3.63 | V |
| VDDSHV3 | IO supply for IO group 3 | -0.3 | 3.63 | V |
| VDDSHV4 | IO supply for IO group 4 | -0.3 | 3.63 | V |
| VDDSHV5 | IO supply for IO group 5 | -0.3 | 3.63 | V |
| VDDA_3P3_USB0 | USB0 3.3V analog supply | -0.3 | 3.63 | V |
| VDDA_3P3_SDIO | SDIO 3.3V analog supply | -0.3 | 3.63 | V |
| Steady-state max voltage at all fail-safe IO pins | MCU_PORz | -0.3 | 3.63 | V |
| | MCU_I2C0_SCL, MCU_I2C0_SDA, I2C0_SCL, I2C0_SDA, and EXTINTn When operating at 1.8V | -0.3 | 1.98 ⁽³⁾ | V |
| | MCU_I2C0_SCL, MCU_I2C0_SDA, I2C0_SCL, I2C0_SDA, and EXTINTn When operating at 3.3V | -0.3 | 3.63 ⁽³⁾ | V |
| | VMON_1P8_MCU and VMON_1P8_SOC | -0.3 | 1.98 | V |
| | VMON_3P3_MCU and VMON_3P3_SOC | -0.3 | 3.63 | V |
| | VMON_VSYS ⁽⁴⁾ | -0.3 | 1.98 | V |

over operating junction temperature range (unless otherwise noted)^{(1) (2)}

| PARAMETER | | MIN | MAX | UNIT |
|--|--|------|--------------------------|------|
| Steady-state max voltage at all other IO pins ⁽⁵⁾ | USB0_VBUS ⁽⁶⁾ | -0.3 | 3.6 | V |
| | USB0_ID ⁽⁷⁾ | -0.3 | 3.6 | V |
| | All other IO pins | -0.3 | IO supply voltage + 0.3 | V |
| Transient overshoot and undershoot at IO pin | 20% of IO supply voltage for up to 20% of the signal period (see Figure 6-1, IO Transient Voltage Ranges) | | 0.2 × VDD ⁽⁸⁾ | V |
| Latch-up performance | I-Test ⁽⁹⁾ | -100 | +100 | mA |
| | Over-Voltage (OV) Test ⁽¹⁰⁾ | | 1.5 × VDD ⁽⁸⁾ | V |
| T _{STG} | Storage temperature ⁽¹¹⁾ | -55 | +150 | °C |

- (1) Operation outside the Absolute Maximum Ratings may cause permanent device damage. Absolute Maximum Ratings do not imply functional operation of the device at these or any other conditions beyond those listed under Recommended Operating Conditions. If used outside [Section 6.4, Recommended Operating Conditions](#) but within the Absolute Maximum Ratings, the device may not be fully functional, and may affect device reliability, functionality, performance, and shorten the device lifetime.
- (2) All voltage values are with respect to VSS, unless otherwise noted.
- (3) The absolute maximum ratings for these fail-safe pins depends on their IO supply operating voltage. Therefore, this value is also defined by the maximum V_{IH} value found in [Section 6.7.1, I2C Open-Drain, and Fail-Safe \(I2C OD FS\) Electrical Characteristics](#), where the electrical characteristics table has separate parameter values for 1.8V mode and 3.3V mode.
- (4) The VMON_VSYS pin provides a way to monitor the system power supply. For more information, see [Section 8.2.5, System Power Supply Monitor Design Guidelines](#).
- (5) This parameter applies to all IO pins which are not fail-safe and the requirement applies to all values of IO supply voltage. For example, if the voltage applied to a specific IO supply is 0 volts the valid input voltage range for any IO powered by that supply will be -0.3 to +0.3 volts. Special attention should be applied anytime peripheral devices are not powered from the same power sources used to power the respective IO supply. It is important the attached peripheral never sources a voltage outside the valid input voltage range, including power supply ramp-up and ramp-down sequences.
- (6) An external resistor divider is required to limit the voltage applied to this device pin. For more information, see [Section 8.2.4, USB VBUS Design Guidelines](#).
- (7) The USB0_ID pin is connected to analog circuits in the USB0 PHY. The analog circuits source a known current while measuring voltage, to determine the resistance value (RID), if connected to VSS through a resistor. This pin should be connected to VSS for USB host operation, or left unconnected for USB device operation, and should never be connected to any external voltage source.
- (8) VDD is the voltage on the corresponding power-supply pin(s) for the IO.
- (9) For current pulse injection (I-Test):
 - Pins stressed per JEDEC JESD78 (Class II) and passed with specified I/O pin injection current and clamp voltage of 1.5 times maximum recommended I/O voltage and negative 0.5 times maximum recommended I/O voltage.
- (10) For over-voltage performance (Over-Voltage (OV) Test):
 - Supplies stressed per JEDEC JESD78 (Class II) and passed specified voltage injection.
- (11) For tape and reel the storage temperature range is [-10°C; +50°C] with a maximum relative humidity of 70%. TI recommends returning to ambient room temperature before usage.

Fail-safe IO terminals are designed without any dependencies on the respective IO power supply voltage. This allows external voltage sources to be connected to these IO terminals when the respective IO power supplies are turned off.

MCU_I2C0_SCL, MCU_I2C0_SDA, I2C0_SCL, I2C0_SDA, EXTINTn, VMON_1P8_MCU, VMON_1P8_SOC, VMON_3P3_MCU, VMON_3P3_SOC, and MCU_PORz are the only fail-safe IO terminals. All other IO terminals are not fail-safe and the voltage applied to them should be limited to the value defined by the *Steady-state max voltage at all other IO pins* parameter in [Section 6.1, Absolute Maximum Ratings](#).

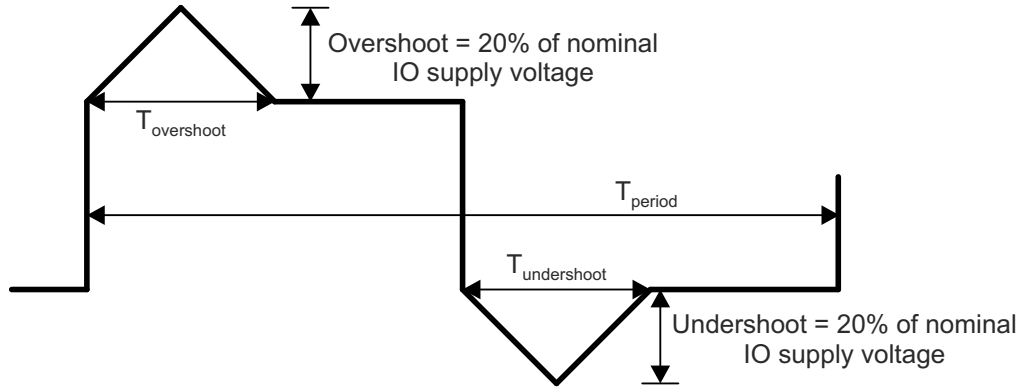

A. $T_{overshoot} + T_{undershoot} < 20\%$ of T_{period}

Figure 6-1. IO Transient Voltage Range

6.2 ESD Ratings

| | | | VALUE | UNIT |
|-------------|-------------------------------|---|-------|------|
| $V_{(ESD)}$ | Electrostatic discharge (ESD) | Human-body model (HBM), per ANSI/ESDA/JEDEC JS-001 ⁽¹⁾ | ±1000 | V |
| | | Charged-device model (CDM), per ANSI/ESDA/JEDEC JS-002 ⁽²⁾ | ±250 | |

(1) JEDEC document JEP155 states that 500V HBM allows safe manufacturing with a standard ESD control process.

(2) JEDEC document JEP157 states that 250V CDM allows safe manufacturing with a standard ESD control process.

6.3 Power-On Hours (POH)

The estimated POH data for continuous device operation at specific junction temperatures is provided in the table below.

| Temperature Rating | Temperature Range | JUNCTION TEMP (T _J) ⁽¹⁾ | ESTIMATED ⁽²⁾ LIFETIME (POH) ⁽³⁾ |
|--------------------|-------------------|--|--|
| A | -40°C to 105°C | 105°C | 100000 |
| I | -40°C to 125°C | 105°C | 100000 |
| | | 110°C | 64000 |
| | | 115°C | 41000 |
| | | 120°C | 26500 |
| | | 125°C | 17500 |

- (1) Unless specified, all voltage domains and operating conditions are supported in the device at the noted temperatures.
- (2) This information is provided solely for your convenience and does not extend or modify the warranty provided under TI's standard terms and conditions for TI semiconductor products.
- (3) POH is a function of voltage, temperature and time. Usage at higher voltages and temperatures results in a reduction in POH.

6.4 Recommended Operating Conditions

over operating junction temperature range (unless otherwise noted)

| SUPPLY NAME | DESCRIPTION | MIN ⁽¹⁾ | NOM | MAX ⁽¹⁾ | UNIT | |
|-----------------------------|--|--------------------|--------------------|--------------------|-------|---|
| VDD_CORE | Core supply | 0.81 | 0.85 | 0.895 | V | |
| VDDR_CORE | RAM supply | 0.81 | 0.85 | 0.895 | V | |
| VDD_MMC0 ⁽²⁾ | MMC0 PHY core supply | 0.81 | 0.85 | 0.895 | V | |
| VDD_DLL_MMC0 ⁽²⁾ | MMC0 PLL analog supply | 0.81 | 0.85 | 0.895 | V | |
| VDDA_0P85_SERDES0 | SERDES0 0.85V analog supply | 0.81 | 0.85 | 0.895 | V | |
| VDDA_0P85_SERDES0_C | SERDES0 clock 0.85V analog supply | 0.81 | 0.85 | 0.895 | V | |
| VDDA_0P85_USB0 | USB0 0.85V analog supply | 0.81 | 0.85 | 0.895 | V | |
| VDDS_DDR ⁽³⁾ | DDR PHY IO supply | 1.06 | 1.1 | 1.17 | V | |
| VDDS_DDR_C ⁽³⁾ | DDR clock IO supply | 1.14 | 1.2 | 1.26 | V | |
| VDDS_MMC0 | MMC0 PHY IO supply | 1.71 | 1.8 | 1.89 | V | |
| VDDS_OSC | MCU_OSC0 supply | 1.71 | 1.8 | 1.89 | V | |
| VDDA_MCU | RCOSC, POR, POK, and MCU_PLL0 analog supply | 1.71 | 1.8 | 1.89 | V | |
| VDDA_ADC0 | ADC0 analog supply | 1.71 | 1.8 | 1.89 | V | |
| VDDA_PLL0 | MAIN_PLL0, MAIN_PLL2, and MAIN_PLL14 analog supply | 1.71 | 1.8 | 1.89 | V | |
| VDDA_PLL1 | MAIN_PLL8 and MAIN_PLL12 analog supply | 1.71 | 1.8 | 1.89 | V | |
| VDDA_PLL2 | MAIN_PLL1 analog supply | 1.71 | 1.8 | 1.89 | V | |
| VDDA_1P8_SERDES0 | SERDES0 1.8V analog supply | 1.71 | 1.8 | 1.89 | V | |
| VDDA_1P8_USB0 | USB0 1.8V analog supply | 1.71 | 1.8 | 1.89 | V | |
| VDDA_TEMP0 | TEMP0 analog supply | 1.71 | 1.8 | 1.89 | V | |
| VDDA_TEMP1 | TEMP1 analog supply | 1.71 | 1.8 | 1.89 | V | |
| VPP | eFuse ROM programming supply | see ⁽⁴⁾ | see ⁽⁴⁾ | see ⁽⁴⁾ | V | |
| VMON_1P8_MCU | Voltage monitor for 1.8V MCU power supply | 1.71 | 1.8 | 1.89 | V | |
| VMON_1P8_SOC | Voltage monitor for 1.8V SoC power supply | 1.71 | 1.8 | 1.89 | V | |
| VDDA_3P3_USB0 | USB0 3.3V analog supply | 3.135 | 3.3 | 3.465 | V | |
| VDDA_3P3_SDIO | SDIO 3.3V analog supply | 3.135 | 3.3 | 3.465 | V | |
| VMON_3P3_MCU | Voltage monitor for 3.3V MCU power supply | 3.135 | 3.3 | 3.465 | V | |
| VMON_3P3_SOC | Voltage monitor for 3.3V SoC power supply | 3.135 | 3.3 | 3.465 | V | |
| VMON_VSYS | Voltage monitor pin | 0 | see ⁽⁵⁾ | 1 | V | |
| USB0_VBUS | USB Level-shifted VBUS Input | 0 | see ⁽⁶⁾ | 3.465 | V | |
| USB0_ID | USB0 analog I/O for RID detection | | see ⁽⁷⁾ | | V | |
| VDDSHV_MCU | Dual-voltage IO supply | 1.8V Operation | 1.71 | 1.8 | 1.89 | V |
| | | 3.3V Operation | 3.135 | 3.3 | 3.465 | V |
| VDDSHV0 | Dual-voltage IO supply | 1.8V Operation | 1.71 | 1.8 | 1.89 | V |
| | | 3.3V Operation | 3.135 | 3.3 | 3.465 | V |
| VDDSHV1 | Dual-voltage IO supply | 1.8V Operation | 1.71 | 1.8 | 1.89 | V |
| | | 3.3V Operation | 3.135 | 3.3 | 3.465 | V |
| VDDSHV2 | Dual-voltage IO supply | 1.8V Operation | 1.71 | 1.8 | 1.89 | V |
| | | 3.3V Operation | 3.135 | 3.3 | 3.465 | V |
| VDDSHV3 | Dual-voltage IO supply | 1.8V Operation | 1.71 | 1.8 | 1.89 | V |
| | | 3.3V Operation | 3.135 | 3.3 | 3.465 | V |
| VDDSHV4 | Dual-voltage IO supply | 1.8V Operation | 1.71 | 1.8 | 1.89 | V |
| | | 3.3V Operation | 3.135 | 3.3 | 3.465 | V |

over operating junction temperature range (unless otherwise noted)

| SUPPLY NAME | DESCRIPTION | MIN ⁽¹⁾ | NOM | MAX ⁽¹⁾ | UNIT | |
|----------------|--------------------------------------|---------------------|-------|--------------------|-------|----|
| VDDSHV5 | Dual-voltage IO supply | 1.8V Operation | 1.71 | 1.8 | 1.89 | V |
| | | 3.3V Operation | 3.135 | 3.3 | 3.465 | V |
| T _J | Operating junction temperature range | 125°C Industrial | -40 | | 125 | °C |
| | | Extended Industrial | -40 | | 105 | |

- (1) The voltage at the device ball must never drop below the MIN voltage or above the MAX voltage for any amount of time during normal device operation.
- (2) VDD_MMC0 and VDD_DLL_MMC0 must be connected to the same power source as VDD_CORE.
- (3) VDDS_DDR and VDDS_DDR_C shall be sourced from the same power source.
- (4) Refer to the [Recommended Operating Conditions for OTP eFuse Programming](#) table for VPP supply voltages based on eFuse usage.
- (5) The VMON_VSYS pin provides a way to monitor the system power supply. For more information, see [System Power Supply Monitor Design Guidelines](#).
- (6) An external resistor divider is required to limit the voltage applied to this device pin. For more information, see [USB Design Guidelines](#).
- (7) The USB0_ID pin is connected to analog circuits in the USB0 PHY. The analog circuits source a known current while measuring voltage, to determine the resistance value (RID), if connected to VSS through a resistor. This pin must be connected to VSS for USB host operation, or left unconnected for USB device operation, and should never be connected to any external voltage source.

6.5 Operating Performance Points

This section describes the operating conditions of the device. This section also contains the description of each Operating Performance Point (OPP) for processor clocks and device core clocks.

[Table 6-1](#) describes the maximum supported frequency per speed grade for the device.

Table 6-1. Speed Grade Maximum Frequency

| DEVICE ⁽¹⁾ | MAXIMUM FREQUENCY (MHz) | | | | | | | |
|-----------------------|-------------------------|-------|-------|---------------|-------|--------|---------------------|-----------------------|
| | SPEED GRADE | R5FSS | M4FSS | INFRA (CBASS) | ICSSG | DMSC-L | DDR4 ⁽²⁾ | LPDDR4 ⁽²⁾ |
| AM243x...ALV | S | 800 | 400 | 250 | 333 | 250 | 800 (DDR-1600) | 800 (LPDDR-1600) |
| AM243x...ANI | | | | | | | | |
| AM243x...ALV | K | 400 | 400 | 250 | 333 | 250 | 800 (DDR-1600) | 800 (LPDDR-1600) |
| AM243x...ANI | | | | | | | | |
| AM243x...ALX | S | 800 | 400 | 250 | 333 | 250 | N/A | N/A |
| AM243x...ALX | K | 400 | 400 | 250 | 333 | 250 | N/A | N/A |

(1) N/A in this table stands for Not Applicable.

(2) Maximum DDR Frequency will be limited based on the specific memory type (vendor) used in a system and by PCB implementation. Refer to [AM64x/AM243x DDR Board Design and Layout Guidelines](#) for the proper PCB implementation to achieve maximum DDR frequency.

6.6 Power Consumption Summary

For information on the device power consumption, see the [AM64x/AM243x Power Estimation Tool](#) application note.

6.7 Electrical Characteristics

Note

The interfaces or signals described in [Section 6.7.1](#) through [Section 6.7.11](#) correspond to the interfaces or signals available in multiplexing mode 0 (Primary Function).

All interfaces or signals multiplexed on the balls described in these tables have the same DC electrical characteristics, unless multiplexing involves a PHY and GPIO combination, in which case different DC electrical characteristics are specified for the different multiplexing modes (Functions).

6.7.1 I2C Open-Drain, and Fail-Safe (I2C OD FS) Electrical Characteristics

over recommended operating conditions (unless otherwise noted)

| PARAMETER | | TEST CONDITIONS | MIN | TYP | MAX | UNIT |
|--------------------------------|---------------------------------|-----------------------|------------------------------------|---------------------------|---------------------|------|
| 1.8V MODE | | | | | | |
| V _{IL} | Input Low Voltage | | | 0.3 × VDD ⁽¹⁾ | | V |
| V _{ILSS} | Input Low Voltage Steady State | | | 0.3 × VDD ⁽¹⁾ | | V |
| V _{IH} | Input High Voltage | | 0.7 × VDD ⁽¹⁾ | | 1.98 ⁽²⁾ | V |
| V _{IHSS} | Input High Voltage Steady State | | 0.7 × VDD ⁽¹⁾ | | | V |
| V _{HYS} | Input Hysteresis Voltage | | 0.1 × VDD ⁽¹⁾ | | | mV |
| I _{IN} ⁽³⁾ | Input Leakage Current. | V _I = 1.8V | | | 10 | μA |
| | | V _I = 0V | | | -10 | μA |
| V _{OL} | Output Low Voltage | | | 0.2 × VDD ⁽¹⁾ | | V |
| I _{OL} ⁽⁴⁾ | Low Level Output Current | V _{OL(MAX)} | 10 | | | mA |
| SR _I ⁽⁶⁾ | Input Slew Rate | | 18f ⁽⁵⁾ or 1.8E+6 | | | V/s |
| 3.3V MODE⁽⁷⁾ | | | | | | |
| V _{IL} | Input Low Voltage | | | 0.3 × VDD ⁽¹⁾ | | V |
| V _{ILSS} | Input Low Voltage Steady State | | | 0.25 × VDD ⁽¹⁾ | | V |
| V _{IH} | Input High Voltage | | 0.7 × VDD ⁽¹⁾ | | 3.63 ⁽²⁾ | V |
| V _{IHSS} | Input High Voltage Steady State | | 0.7 × VDD ⁽¹⁾ | | | V |
| V _{HYS} | Input Hysteresis Voltage | | 0.05 × VDD ⁽¹⁾ | | | mV |
| I _{IN} ⁽³⁾ | Input Leakage Current. | V _I = 3.3V | | | 10 | μA |
| | | V _I = 0V | | | -10 | μA |
| V _{OL} | Output Low Voltage | | | 0.4 | | V |
| I _{OL} ⁽⁴⁾ | Low Level Output Current | V _{OL(MAX)} | 10 | | | mA |
| SR _I ⁽⁶⁾ | Input Slew Rate | | 33f ⁽⁵⁾ or 3.3E+6 | | 8E+7 | V/s |

(1) VDD stands for corresponding power supply. For more information on the power supply name and the corresponding ball(s), see POWER column of the *Pin Attributes* table.

(2) This value also defines the Absolute Maximum Ratings value the IO.

(3) This parameter defines leakage current when the terminal is operating as an input, undriven output, or both input and undriven output.

(4) The I_{OL} parameter defines the minimum Low Level Output Current for which the device is able to maintain the specified V_{OL} value. The value defined by this parameter should be considered the maximum current available to a system implementation which needs to maintain the specified V_{OL} value for attached components.

(5) f = toggle frequency of the input signal in Hz.

(6) This MIN parameter only applies to input signal functions which are not defined in their respective *Timing and Switching Characteristics* sections. Select the MIN parameter which results in the largest value.

(7) I2C Hs-mode is not supported when operating the IO in 3.3V mode.

6.7.2 Fail-Safe Reset (FS RESET) Electrical Characteristics

over recommended operating conditions (unless otherwise noted)

| PARAMETER | | TEST CONDITIONS | MIN | TYP | MAX | UNIT |
|--------------------------------|---------------------------------|-----------------------|------------------------------------|-----|-------------------------------|------|
| V _{IL} | Input Low Voltage | | | | 0.3 × V _{DD5_OSC} | V |
| V _{ILSS} | Input Low Voltage Steady State | | | | 0.3 × V _{DD5_OSC} | V |
| V _{IH} | Input High Voltage | | 0.7 × V _{DD5_OSC} | | | V |
| V _{IHSS} | Input High Voltage Steady State | | 0.7 × V _{DD5_OSC} | | | V |
| V _{HYS} | Input Hysteresis Voltage | | 200 | | | mV |
| I _{IN} ⁽¹⁾ | Input Leakage Current. | V _I = 1.8V | | | 10 | μA |
| | | V _I = 0V | | | -10 | μA |
| SR _I ⁽³⁾ | Input Slew Rate | | 18f ⁽²⁾ or 1.8E+6 | | | V/s |

- (1) This parameter defines leakage current when the terminal is operating as an input.
 (2) f = toggle frequency of the input signal in Hz.
 (3) This MIN parameter only applies to input signal functions which are not defined in their respective *Timing and Switching Characteristics* sections. Select the MIN parameter which results in the largest value.

6.7.3 High-Frequency Oscillator (HFOSC) Electrical Characteristics

over recommended operating conditions (unless otherwise noted)

| PARAMETER | | TEST CONDITIONS | MIN | TYP | MAX | UNIT |
|--------------------------------|--------------------------|-----------------------|--------------------------------|-----|--------------------------------|------|
| V _{IL} | Input Low Voltage | | | | 0.35 × V _{DD5_OSC} | V |
| V _{IH} | Input High Voltage | | 0.65 × V _{DD5_OSC} | | | V |
| V _{HYS} | Input Hysteresis Voltage | | | 49 | | mV |
| I _{IN} ⁽¹⁾ | Input Leakage Current. | V _I = 1.8V | | | 10 | μA |
| | | V _I = 0V | | | -10 | μA |

- (1) This parameter defines leakage current when the terminal is operating as an input.

6.7.4 eMMCPHY Electrical Characteristics

over recommended operating conditions (unless otherwise noted)

| PARAMETER | | TEST CONDITIONS | MIN | TYP | MAX | UNIT |
|--------------------------------|---------------------------------|------------------------|------------------------------|-----|------------------------------|------|
| V _{IL} | Input Low Voltage | | | | 0.35 × V _{DD5_MMC0} | V |
| V _{ILSS} | Input Low Voltage Steady State | | | | 0.20 | V |
| V _{IH} | Input High Voltage | | 0.65 × V _{DD5_MMC0} | | | V |
| V _{IHSS} | Input High Voltage Steady State | | 1.4 | | | V |
| I _{IN} ⁽¹⁾ | Input Leakage Current. | V _I = 1.8V | | | 10 | μA |
| | | V _I = 0V | | | -10 | μA |
| R _{PU} | Pull-up Resistor | | 15 | 20 | 25 | kΩ |
| R _{PD} | Pull-down Resistor | | 15 | 20 | 25 | kΩ |
| V _{OL} | Output Low Voltage | I _{OL} = 2mA | | | 0.30 | V |
| V _{OH} | Output High Voltage | I _{OH} = -2mA | V _{DD5_MMC0} - 0.30 | | | V |
| SR _I | Input Slew Rate | | 5E+8 | | | V/s |

- (1) This parameter defines leakage current when the terminal is operating as an input, undriven output, or both input and undriven output, without internal pulls enabled.

6.7.5 SDIO Electrical Characteristics

over recommended operating conditions (unless otherwise noted)

| PARAMETER | | TEST CONDITIONS | MIN | TYP | MAX | UNIT |
|--------------------------------|---------------------------------|-----------------------|------------------------------------|---------------------------|----------------------------|------|
| 1.8V MODE | | | | | | |
| V _{IL} | Input Low Voltage | | | | 0.58 | V |
| V _{ILSS} | Input Low Voltage Steady State | | | | 0.58 | V |
| V _{IH} | Input High Voltage | | 1.27 | | | V |
| V _{IHSS} | Input High Voltage Steady State | | 1.7 | | | V |
| V _{HYS} | Input Hysteresis Voltage | | 150 | | | mV |
| I _{IN} ⁽¹⁾ | Input Leakage Current. | V _I = 1.8V | | | 10 | μA |
| | | V _I = 0V | | | -10 | μA |
| R _{PU} | Pull-up Resistor | | 40 | 50 | 60 | kΩ |
| R _{PD} | Pull-down Resistor | | 40 | 50 | 60 | kΩ |
| V _{OL} | Output Low Voltage | | | | 0.45 | V |
| V _{OH} | Output High Voltage | | VDD ⁽²⁾ - 0.45 | | | V |
| I _{OL} ⁽³⁾ | Low Level Output Current | V _{OL(MAX)} | 4 | | | mA |
| I _{OH} ⁽³⁾ | High Level Output Current | V _{OH(MIN)} | 4 | | | mA |
| SR _I ⁽⁵⁾ | Input Slew Rate | | 18f ⁽⁴⁾ or 1.8E+6 | | | V/s |
| 3.3V MODE | | | | | | |
| V _{IL} | Input Low Voltage | | | 0.25 × VDD ⁽²⁾ | | V |
| V _{ILSS} | Input Low Voltage Steady State | | | 0.15 × VDD ⁽²⁾ | | V |
| V _{IH} | Input High Voltage | | 0.625 × VDD ⁽²⁾ | | | V |
| V _{IHSS} | Input High Voltage Steady State | | 0.625 × VDD ⁽²⁾ | | | V |
| V _{HYS} | Input Hysteresis Voltage | | 150 | | | mV |
| I _{IN} ⁽¹⁾ | Input Leakage Current. | V _I = 3.3V | | | 10 | μA |
| | | V _I = 0V | | | -10 | μA |
| R _{PU} | Pull-up Resistor | | 40 | 50 | 60 | kΩ |
| R _{PD} | Pull-down Resistor | | 40 | 50 | 60 | kΩ |
| V _{OL} | Output Low Voltage | | | | 0.125 × VDD ⁽²⁾ | V |
| V _{OH} | Output High Voltage | | 0.75 × VDD ⁽²⁾ | | | V |
| I _{OL} ⁽³⁾ | Low Level Output Current | V _{OL(MAX)} | 6 | | | mA |
| I _{OH} ⁽³⁾ | High Level Output Current | V _{OH(MIN)} | 10 | | | mA |
| SR _I ⁽⁵⁾ | Input Slew Rate | | 33f ⁽⁴⁾ or 3.3E+6 | | | V/s |

- (1) This parameter defines leakage current when the terminal is operating as an input, undriven output, or both input and undriven output, without internal pulls enabled.
- (2) VDD stands for corresponding power supply. For more information on the power supply name and the corresponding ball(s), see POWER column of the *Pin Attributes* table.
- (3) The I_{OL} and I_{OH} parameters define the minimum Low Level Output Current and High Level Output Current for which the device is able to maintain the specified V_{OL} and V_{OH} values. Values defined by these parameters should be considered the maximum current available to a system implementation which needs to maintain the specified V_{OL} and V_{OH} values for attached components.
- (4) f = toggle frequency of the input signal in Hz.
- (5) This MIN parameter only applies to input signal functions which are not defined in their respective *Timing and Switching Characteristics* sections. Select the MIN parameter which results in the largest value.

6.7.6 LVCMOS Electrical Characteristics

over recommended operating conditions (unless otherwise noted)

| PARAMETER | | TEST CONDITIONS | MIN | TYP | MAX | UNIT |
|--------------------------------|---------------------------------|-----------------------|------------------------------------|---------------------------|------|------|
| 1.8V MODE | | | | | | |
| V _{IL} | Input Low Voltage | | | 0.35 × VDD ⁽¹⁾ | | V |
| V _{ILSS} | Input Low Voltage Steady State | | | 0.3 × VDD ⁽¹⁾ | | V |
| V _{IH} | Input High Voltage | | 0.65 × VDD ⁽¹⁾ | | | V |
| V _{IHSS} | Input High Voltage Steady State | | 0.85 × VDD ⁽¹⁾ | | | V |
| V _{HYS} | Input Hysteresis Voltage | | 150 | | | mV |
| I _{IN} ⁽²⁾ | Input Leakage Current. | V _I = 1.8V | | | 10 | μA |
| | | V _I = 0V | | | -10 | μA |
| R _{PU} | Pull-up Resistor | | 15 | 22 | 30 | kΩ |
| R _{PD} | Pull-down Resistor | | 15 | 22 | 30 | kΩ |
| V _{OL} | Output Low Voltage | | | | 0.45 | V |
| V _{OH} | Output High Voltage | | VDD ⁽¹⁾ - 0.45 | | | V |
| I _{OL} ⁽³⁾ | Low Level Output Current | V _{OL(MAX)} | 3 | | | mA |
| I _{OH} ⁽³⁾ | High Level Output Current | V _{OH(MIN)} | 3 | | | mA |
| SR _I ⁽⁵⁾ | Input Slew Rate | | 18f ⁽⁴⁾ or 1.8E+6 | | | V/s |
| 3.3V MODE | | | | | | |
| V _{IL} | Input Low Voltage | | | | 0.8 | V |
| V _{ILSS} | Input Low Voltage Steady State | | | | 0.6 | V |
| V _{IH} | Input High Voltage | | 2.0 | | | V |
| V _{IHSS} | Input High Voltage Steady State | | 2.0 | | | V |
| V _{HYS} | Input Hysteresis Voltage | | 150 | | | mV |
| I _{IN} ⁽²⁾ | Input Leakage Current. | V _I = 3.3V | | | 10 | μA |
| | | V _I = 0V | | | -10 | μA |
| R _{PU} | Pull-up Resistor | | 15 | 22 | 30 | kΩ |
| R _{PD} | Pull-down Resistor | | 15 | 22 | 30 | kΩ |
| V _{OL} | Output Low Voltage | | | | 0.4 | V |
| V _{OH} | Output High Voltage | | 2.4 | | | V |
| I _{OL} ⁽³⁾ | Low Level Output Current | V _{OL(MAX)} | 5 | | | mA |
| I _{OH} ⁽³⁾ | High Level Output Current | V _{OH(MIN)} | 9 | | | mA |
| SR _I ⁽⁵⁾ | Input Slew Rate | | 33f ⁽⁴⁾ or 3.3E+6 | | | V/s |

- (1) VDD stands for corresponding power supply. For more information on the power supply name and the corresponding ball(s), see POWER column of the *Pin Attributes* table.
- (2) This parameter defines leakage current when the terminal is operating as an input, undriven output, or both input and undriven output, without internal pulls enabled.
- (3) The I_{OL} and I_{OH} parameters define the minimum Low Level Output Current and High Level Output Current for which the device is able to maintain the specified V_{OL} and V_{OH} values. Values defined by these parameters should be considered the maximum current available to a system implementation which needs to maintain the specified V_{OL} and V_{OH} values for attached components.
- (4) f = toggle frequency of the input signal in Hz.
- (5) This MIN parameter only applies to input signal functions which are not defined in their respective *Timing and Switching Characteristics* sections. Select the MIN parameter which results in the largest value.

6.7.7 ADC12B Electrical Characteristics (ALV/ANI package)

over recommended operating conditions (unless otherwise noted)

| PARAMETER | | TEST CONDITIONS | MIN | TYP | MAX | UNIT |
|--|--|---|------------------|-----------|------------------|----------------------|
| Resolution (ALV/ANI package) | | | | 12 | | Bits |
| V _{ADC0_VREFP} ⁽¹⁾ | Positive Reference Voltage, ADC0_VREFP | | 1.71 | | 1.89 | V |
| V _{ADC0_VREFN} ⁽¹⁾ | Negative Reference Voltage, ADC0_VREFN | | | VSS | | V |
| V _{ADC_AIN[7:0]} | Analog Input Voltage, ADC_AIN[7:0], Full-scale | | VSS | VDDA_ADC0 | | V |
| DNL | Differential Non-Linearity | | > -1 | | +1 | LSB |
| INL | Integral Non-Linearity | | -2 | | +2 | LSB |
| LSB _{GAIN-ERROR} | Gain Error | | | ±10 | | LSB |
| LSB _{OFFSET-ERROR} | Offset Error | | | ±5 | | LSB |
| SNR | Signal-to-Noise Ratio | Input Signal: 200kHz sine wave at -0.5dB Full Scale | | 70 | | dB |
| THD | Total Harmonic Distortion | Input Signal: 200kHz sine wave at -0.5dB Full Scale | | -75 | | dB |
| Z _{ADC_AIN[0:7]} | Analog Input Impedance, ADC0_AIN[7:0] | | | (2) | | Ω |
| I _{IN} | Input Leakage | | | ±10 | | μA |
| C _{SMPL} | Sampling Capacitance | | | 5.5 | | pF |
| Sampling Dynamics | | | | | | |
| F _{SMPL_CLK} | ADC0 SMPL_CLK Frequency | | | 60 | | MHz |
| t _C | Conversion Time | | | 13 | | ADC0 SMPL_CLK Cycles |
| t _{ACQ} | Acquisition Time | | 2 | | 257 | ADC0 SMPL_CLK Cycles |
| T _R | Sampling Rate | ADC0 SMPL_CLK = 60MHz | | | 4 | MSPS |
| General Purpose Input Mode ⁽³⁾ | | | | | | |
| V _{IL} | Input Low Voltage | | | | 0.35 × VDDA_ADC0 | V |
| V _{ILSS} | Input Low Voltage Steady State | | | | 0.35 × VDDA_ADC0 | V |
| V _{IH} | Input High Voltage | | 0.65 × VDDA_ADC0 | | | V |
| V _{IHSS} | Input High Voltage Steady State | | 0.65 × VDDA_ADC0 | | | V |
| V _{HYS} | Input Hysteresis Voltage | | 200 | | | mV |
| I _I ⁽⁴⁾ | Input Leakage Current | ADC0_AIN[7:0] = VDDA_ADC0 | | | 10 | μA |
| | | ADC0_AIN[7:0] = VSS | | | -10 | μA |

- (1) The ADC0_REFP and ADC0_REFN reference inputs are analog inputs which must be treated like high transient power supply rails. ADC0_REFN is expected to be connected directly to the PCB ground plane along with all other VSS pins, and ADC0_REFP is connected to a power source capable of providing at least 4mA of current. ADC0_REFP can be connected to the same power source as VDDA_ADC0 if the voltage tolerance of the supply provides an acceptable accuracy for the ADC reference. A high frequency decoupling capacitor must be connected directly to the ADC0_REFP and ADC0_REFN pins with vias and be placed in the ball array on the back side of the PCB.

- (2) The ADC0_AIN pins are connected to an internal sampling capacitor for a user configurable acquisition time and acquisition frequency. The input impedance of the ADC0_AIN pins is a function of the sampling capacitance along with user configurable acquisition time and acquisition frequency. The designer must understand the time required for the source impedance of each ADC0_AIN pin to charge the internal sampling capacitor. The acquisition time must be set long enough for the internal sampling capacitor to settle to greater than 14 bits of accuracy.
- (3) ADC0 can be configured to operate in General Purpose Input mode, where all ADC0_AIN[7:0] inputs are globally enabled to operate as digital inputs via the ADC0_CTRL register (gpi_mode_en = 1).
- (4) This parameter defines leakage current when the terminal is operating as a general purpose input.

6.7.8 ADC10B Electrical Characteristics (ALX package)

over recommended operating conditions (unless otherwise noted)

| PARAMETER | | TEST CONDITIONS | MIN | TYP | MAX | UNIT |
|--|--|--|------|-----------------------------|-----------------------------|----------------------------|
| Resolution (ALX package) | | | | 10 | | Bits |
| V_{ADC0_VREFP} ⁽¹⁾ | Positive Reference Voltage | | 1.71 | | 1.89 | V |
| V_{ADC0_VREFN} ⁽¹⁾ | Negative Reference Voltage | | | VSS | | V |
| $V_{ADC_AIN[7:0]}$ | Analog Input Voltage, ADC_AIN[7:0], Full-scale | | VSS | VDDA_ADC0 | | V |
| DNL | Differential Non-Linearity | | > -1 | | +1 | LSB |
| INL | Integral Non-Linearity | | -2 | | +2 | LSB |
| LSB _{GAIN-ERROR} | Gain Error | | | ±10 | | LSB |
| LSB _{OFFSET-ERROR} | Offset Error | | | ±5 | | LSB |
| SNR | Signal-to-Noise Ratio | Input Signal: 200kHz sine wave at -0.5 dB Full Scale | | 65 | | dB |
| THD | Total Harmonic Distortion | Input Signal: 200kHz sine wave at -0.5 dB Full Scale | | -64 | | dB |
| $Z_{ADC_AIN[0:7]}$ | Analog Input Impedance, ADC0_AIN[7:0] | | | ⁽²⁾ | | Ω |
| I_{IN} | Input Leakage | | | ±10 | | μA |
| C_{SMPL} | Sampling Capacitance | | | 5.5 | | pF |
| Sampling Dynamics | | | | | | |
| F_{SMPL_CLK} | ADC0 SMPL_CLK Frequency | | | 60 | | MHz |
| t_C | Conversion Time | | | 13 | | ADC0 SMPL_CLK Cycles |
| t_{ACQ} | Acquisition Time | | 2 | | 257 | ADC0 SMPL_CLK Cycles |
| T_R | Sampling Rate | ADC0 SMPL_CLK = 60MHz | | | 4 | MSPS |
| General Purpose Input Mode ⁽³⁾ | | | | | | |
| V_{IL} | Input Low Voltage | | | | $0.35 \times V_{DDA_ADC0}$ | V |
| V_{ILSS} | Input Low Voltage Steady State | | | | $0.35 \times V_{DDA_ADC0}$ | V |
| V_{IH} | Input High Voltage | | | $0.65 \times V_{DDA_ADC0}$ | | V |
| V_{IHSS} | Input High Voltage Steady State | | | $0.65 \times V_{DDA_ADC0}$ | | V |
| V_{HYS} | Input Hysteresis Voltage | | | 200 | | mV |
| I_I | Input Leakage Current | ADC0_AIN[7:0] = VDDA_ADC0 or ADC0_AIN[7:0] = VSS | | | 10 | μA |

- (1) ADC0_REFP and ADC0_REFN are directly connected to VDDA_ADC0 and VSS inside the SoC. References to ADC0_REFP and ADC0_REFN in this table must be considered as VDDA_ADC0 or VSS.
- (2) The ADC0_AIN pins are connected to an internal sampling capacitor for a user configurable acquisition time and acquisition frequency. The input impedance of the ADC0_AIN pins is a function of the sampling capacitance along with user configurable acquisition time and acquisition frequency. The designer must understand the time required for the source impedance of each ADC0_AIN pin to charge the internal sampling capacitor. The acquisition time must be set long enough for the internal sampling capacitor to settle to greater than 14 bits of accuracy.

- (3) ADC0 can be configured to operate in General Purpose Input mode, where all ADC0_AIN[7:0] inputs are globally enabled to operate as digital inputs via the ADC0_CTRL register (GPI_MODE_EN = 1).

6.7.9 USB2PHY Electrical Characteristics

Note

USB0 interface is compliant with Universal Serial Bus Revision 2.0 Specification dated April 27, 2000 including ECNs and Errata as applicable.

6.7.10 SerDes PHY Electrical Characteristics

Note

The PCIe interface is compliant with the electrical parameters specified in PCI Express® Base Specification Revision 4.0, February 19, 2014.

Note

USB0 instance is compliant with the USB3.1 SuperSpeed Transmitter and Receiver Normative Electrical Parameters as defined in the Universal Serial Bus 3.1 Specification, Revision 1.0 , July 26, 2013.

6.7.11 DDR Electrical Characteristics

Note

The DDR interface is compatible with DDR4 devices that are **JESD79-4B standard-compliant**, and LPDDR4 devices that are **JESD209-4B standard-compliant**

6.8 VPP Specifications for One-Time Programmable (OTP) eFuses

This section specifies the operating conditions required for programming the OTP eFuses..

6.8.1 Recommended Operating Conditions for OTP eFuse Programming

over operating junction temperature range (unless otherwise noted)

| PARAMETER | DESCRIPTION | MIN | NOM | MAX | UNIT |
|---------------------|---|---|-----|------|------|
| VDD_CORE | Supply voltage range for the core domain during OTP operation | See <i>Recommended Operating Conditions</i> | | | V |
| VPP | Supply voltage range for the eFuse ROM domain during normal operation without hardware support to program eFuse ROM | NC ⁽¹⁾ | | | V |
| | Supply voltage range for the eFuse ROM domain during normal operation with hardware support to program eFuse ROM | 0 | | | V |
| | Supply voltage range for the eFuse ROM domain during OTP programming ⁽²⁾ | 1.71 | 1.8 | 1.89 | V |
| I _(VPP) | VPP current | 400 | | | mA |
| SR _(VPP) | VPP Power-up Slew Rate | 6E+4 | | | V/s |
| T _J | Operating junction temperature range while programming eFuse ROM. | 0 | 25 | 85 | °C |

(1) NC stands for No Connect.

(2) Supply voltage range includes DC errors and peak-to-peak noise.

6.8.2 Hardware Requirements

The following hardware requirements must be met when programming keys in the OTP eFuses:

- The VPP power supply must be disabled when not programming OTP registers.
- The VPP power supply must be ramped up after the proper device power-up sequence (for more details, see [Section 6.11.2, Power Supply Sequencing](#)).

6.8.3 Programming Sequence

Programming sequence for OTP eFuses:

- Power on the board per the power-up sequencing. No voltage should be applied on the VPP terminal during power up and normal operation.
- Load the OTP write software required to program the eFuse (contact your local TI representative for the OTP software package).
- Apply the voltage on the VPP terminal according to the specification in [Section 6.8.1](#).
- Run the software that programs the OTP registers.
- After validating the content of the OTP registers, remove the voltage from the VPP terminal.

6.8.4 Impact to Your Hardware Warranty

You accept that eFusing the TI Devices with security keys permanently alters them. You acknowledge that the eFuse can fail, for example, due to incorrect or aborted program sequence or if you omit a sequence step. Further the TI device may fail to secure boot if the error code correction check fails for the Production Keys or if the image is not signed and optionally encrypted with the current active Production Keys. These types of situations will render the TI device inoperable and TI will be unable to confirm whether the TI devices conformed to their specifications prior to the attempted eFuse. Consequently, TI will have no liability (*warranty or otherwise*) for any TI devices that have been incorrectly eFused by customers.

6.9 Thermal Resistance Characteristics

For operation and reliability concerns, the maximum junction temperature of the device must be equal to or less than the T_J value identified in *Recommended Operating Conditions*.

Note

The thermal parameters are generated following JEDEC standard JESD51x and are not intended for design parameters. If you need a more accurate thermal representation, download the processor thermal model and import your PCB design into a thermal simulation environment. For details on thermal implementation guidelines, see the [Thermal Solution Guidance](#) section.

6.9.1 Thermal Resistance Characteristics

Table 6-2. Thermal Resistance Characteristics

TI recommends performing system level thermal simulations with worst case device power consumption.

| NO. | PARAMETER | DESCRIPTION | ALX Package °C/W ^{(1) (2)} | ALV Package °C/W ^{(1) (2)} | ANI Package °C/W ^{(1) (2)} | AIR FLOW (m/s) ⁽³⁾ |
|-----|----------------|-------------------------|--|--|--|----------------------------------|
| T1 | $R\theta_{JC}$ | Junction-to-case | 4.8 | 0.98 | 3.0 | N/A |
| T2 | $R\theta_{JB}$ | Junction-to-board | 5.4 | 3.87 | 8.2 | N/A |
| T3 | $R\theta_{JA}$ | Junction-to-free air | 19.8 | 12.8 | 18.7 | 0 |
| T4 | $R\theta_{JA}$ | Junction-to-moving air | 14.1 | 9.2 | 13.8 | 1 |
| T5 | | | 13 | 8.2 | 12.8 | 2 |
| T6 | | | 12.3 | 7.6 | 12.3 | 3 |
| T7 | Ψ_{JT} | Junction-to-package top | 0.06 | 0.53 | 0.08 | 0 |
| T8 | | | 0.16 | 0.55 | 0.14 | 1 |
| T9 | | | 0.21 | 0.57 | 0.17 | 2 |
| T10 | | | 0.25 | 0.58 | 0.20 | 3 |
| T11 | Ψ_{JB} | Junction-to-board | 5.3 | 3.74 | 8.1 | 0 |
| T12 | | | 4.95 | 3.5 | 7.6 | 1 |
| T13 | | | 4.88 | 3.4 | 7.4 | 2 |
| T14 | | | 4.83 | 3.3 | 7.3 | 3 |

(1) These values are based on a JEDEC defined 2S2P system (with the exception of the Theta JC [$R\theta_{JC}$] value, which is based on a JEDEC defined 1S0P system) and is subject to change based on environment as well as application. For more information, see the EIA/JEDEC standards.

- JESD51-2, *Integrated Circuits Thermal Test Method Environment Conditions - Natural Convection (Still Air)*
- JESD51-3, *Low Effective Thermal Conductivity Test Board for Leaded Surface Mount Packages*
- JESD51-6, *Integrated Circuit Thermal Test Method Environmental Conditions - Forced Convection (Moving Air)*
- JESD51-7, *High Effective Thermal Conductivity Test Board for Leaded Surface Mount Packages*
- JESD51-9, *Test Boards for Area Array Surface Mount Packages*

(2) °C/W = degrees Celsius per watt.

(3) m/s = meters per second.

6.10 Temperature Sensor Characteristics

This section summarizes the Voltage and Temperature Module (VTM) on die temperature sensor characteristics.

For operation and reliability concerns, the maximum junction temperature of the device must be equal to or less than the T_J value identified in *Recommended Operating Conditions*.

Table 6-3. VTM Die Temperature Sensor Characteristics

| PARAMETER | | TEST CONDITIONS | MIN | TYP | MAX | UNIT |
|-----------|---------------------------------|-----------------|-----|-----|-----|------|
| T_{acc} | VTM temperature sensor accuracy | -40°C to 125°C | -5 | | 5 | °C |

6.11 Timing and Switching Characteristics

This section describes the device Timing Parameters and Switching Characteristics.

Note

The default PADCONFIG settings for output slew rate and/or drive strength must be used to ensure compliance with timing specifications, unless specific instructions are provided otherwise. Modifying these settings may affect signal integrity and timing performance.

For more information on the supported PADCONFIG options, see the *Pad Configuration Registers* section of the device TRM.

6.11.1 Timing Parameters and Information

The timing parameter symbols used in *Timing and Switching Characteristics* sections are created in accordance with JEDEC Standard 100. To shorten the symbols, some pin names and other related terminologies have been abbreviated in [Table 6-4](#):

Table 6-4. Timing Parameters Subscripts

| SYMBOL | PARAMETER |
|--------|--|
| c | Cycle time (period) |
| d | Delay time |
| dis | Disable time |
| en | Enable time |
| h | Hold time |
| su | Setup time |
| START | Start bit |
| t | Transition time |
| v | Valid time |
| w | Pulse duration (width) |
| X | Unknown, changing, or don't care level |
| F | Fall time |
| H | High |
| L | Low |
| R | Rise time |
| V | Valid |
| IV | Invalid |
| AE | Active Edge |
| FE | First Edge |
| LE | Last Edge |
| Z | High impedance |

6.11.2 Power Supply Requirements

This section describes the power supply requirements to ensure proper device operation.

Note

All power balls must be supplied with the voltages specified in the *Recommended Operating Conditions* section, unless otherwise specified in *Signal Descriptions* and *Pin Connectivity Requirements*.

6.11.2.1 Power Supply Slew Rate Requirement

To maintain the safe operating range of the internal ESD protection devices, TI recommends limiting the maximum slew rate of supplies to be less than 18mV/μs. For instance, as shown in [Figure 6-2](#), TI recommends having the supply ramp slew for a 1.8V supply of more than 100μs.

[Figure 6-2](#) describes the Power Supply Slew Rate Requirement in the device.

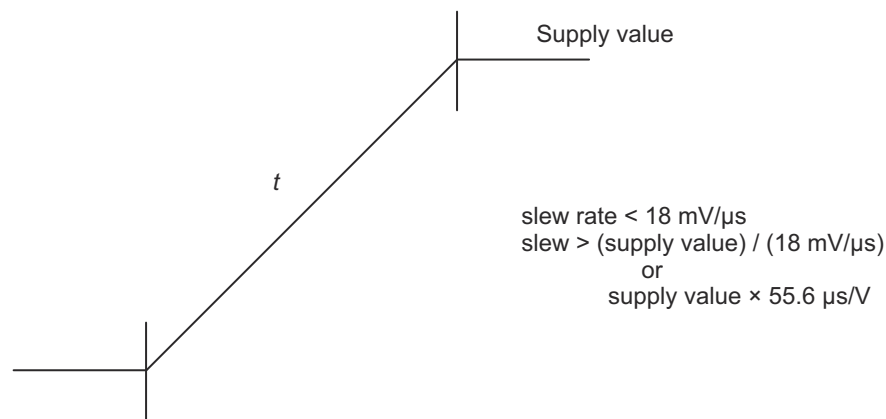

SPRT740_ELCH_06

Figure 6-2. Power Supply Slew and Slew Rate

6.11.2.2 Power Supply Sequencing

This section describes power sequence requirements using power sequence diagrams and associated notes. Each power sequence diagram demonstrates the sequential order expected for each device power rail. This is done by assigning each device power rail to one or more waveform. A dual-voltage power rail may be associated with more than one waveform and the associated note will describe which waveform is applicable. Each waveform defines a transition region for the associated power rails and shows its sequential relationship to the transition regions of other power rails. The notes associated with the power sequence diagram provides further detail of these requirements. See the *Power-up Sequence* section for details on power-up requirements, and the *Power-down Sequence* section for details on power-down requirements.

Two types of power supply transition regions are used to simplify the power supply sequencing diagrams. The legends shown in [Figure 6-3](#) and [Figure 6-4](#) along with their descriptions are provided to clarify what each transition regions represents.

[Figure 6-3](#) defines a transition region with multiple power rails which may be sourced from multiple power supplies or a single power supply. Transitions shown within the transition region represent a use case where multiple power supplies are used to source power rails associated with this waveform, and these power supplies are allowed to ramp at different times within the region since they do not have any specific sequence requirement relative to each other.

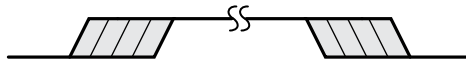

Figure 6-3. Multiple Power Supply Transition Legend

[Figure 6-4](#) defines a transition region with one or more power rails which must be sourced from a single common power supply. No transitions are shown within the region to represent a single ramp within the transition region.

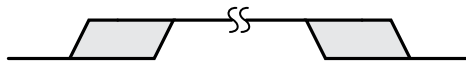

Figure 6-4. Single Common Power Supply Transition Legend

6.11.2.2.1 Power-Up Sequencing

Table 6-6 and Figure 6-6 describe the device power-up sequencing.

Note

All power rails must be turned off and decay below 300mV before initiating a new power-up sequence anytime a power rail drops below the minimum value defined in *Recommended Operating Conditions*.

Table 6-5. Power-Up Sequencing – Supply / Signal Assignments

See: Figure 6-6

| WAVEFORM | SUPPLY / SIGNAL NAME |
|----------|---|
| A | VSYS ⁽¹⁾ , VMON_VSYS ⁽²⁾ |
| B | VDDSHV_MCU ⁽³⁾ , VDDSHV0 ⁽³⁾ , VDDSHV1 ⁽³⁾ , VDDSHV2 ⁽³⁾ , VDDSHV3 ⁽³⁾ , VDDSHV4 ⁽³⁾ , VDDA_3P3_USB0, VMON_3P3_SOC ⁽⁴⁾ , VMON_3P3_MCU ⁽⁴⁾ |
| C | VDDSHV_MCU ⁽⁵⁾ , VDDSHV0 ⁽⁵⁾ , VDDSHV1 ⁽⁵⁾ , VDDSHV2 ⁽⁵⁾ , VDDSHV3 ⁽⁵⁾ , VDDSHV4 ⁽⁵⁾ , VDDA_MCU, VDDS_OSC, VDDA_ADC0, VDDA_PLL0, VDDA_PLL1, VDDA_PLL2, VDDA_1P8_SERDES0, VDDA_1P8_USB0, VMON_1P8_SOC ⁽⁶⁾ , VMON_1P8_MCU ⁽⁶⁾ , VDDA_TEMP0, VDDA_TEMP1, VDDS_MMC0 |
| D | VDDA_3P3_SDIO ^{(7) (8)} , VDDSHV5 ⁽⁷⁾ |
| E | VDDS_DDR ⁽⁹⁾ , VDDS_DDR_C ⁽⁹⁾ |
| G | VDD_CORE ⁽¹⁰⁾ , VDDA_0P85_USB0 ⁽¹⁰⁾ , VDDA_0P85_SERDES0 ⁽¹⁰⁾ , VDDA_0P85_SERDES0_C ⁽¹⁰⁾ , VDD_MMC0 ⁽¹⁰⁾ , VDDA_DLL_MMC0 ⁽¹⁰⁾ , VDDR_CORE ^{(10) (10)} |
| H | VPP ⁽¹¹⁾ |
| I | MCU_PORz |
| J | MCU_OSC0_XI, MCU_OSC0_XO |

- (1) VSYS represents the name of a supply which sources power to the entire system. This supply is expected to be a pre-regulated supply that sources power management devices which source all other supplies.
- (2) VMON_VSYS input is used to monitor VSYS via an external resistor divider circuit. For more information, see Section 8.2.5, *System Power Supply Monitor Design Guidelines*.
- (3) VDDSHV_MCU and VDDSHVx [x=0-4] are dual voltage IO supplies which can be operated at 1.8V or 3.3V depending on the application requirements.
When any of the VDDSHV_MCU or VDDSHVx [x=0-4] IO supplies are operating at 3.3V, they shall be ramped up with other 3.3V supplies during the 3.3V ramp period defined by this waveform.
- (4) The VMON_3P3_MCU and VMON_3P3_SOC inputs are used to monitor supply voltage and shall be connected to the respective 3.3V supply source.
- (5) VDDSHV_MCU and VDDSHVx [x=0-4] are dual voltage IO supplies which can be operated at 1.8V or 3.3V depending on the application requirements.
When any of the VDDSHV_MCU or VDDSHVx [x=0-4] IO supplies are operating at 1.8V, they shall be ramped up with other 1.8V supplies during the 1.8V ramp period defined by this waveform.
- (6) The VMON_1P8_MCU and VMON_1P8_SOC inputs are used to monitor supply voltage and shall be connected to the respective 1.8V supply source.
- (7) VDDA_3P3_SDIO was designed to support power-up or power-down without any dependency on other power rails. VDDSHV5 is a dual voltage IO supply that was designed to support power-up, power-down, or dynamic voltage change without any dependency on other power rails. This capability is required to support UHS-I SD Cards.
- (8) VDDA_3P3_SDIO is the 3.3V power rail for the internal SDIO_LDO. This power rail must be sourced from the same 3.3V power supply that provides power to a UHS-I SD Card connected to MMC1, which allows the MMC1 IOs and the SD Card IOs to power-up and power-down at the same time when the SD Card power supply is powered off to reset the SD Card. For this use case the SDIO_LDO output (CAP_VDDSHV_MMC1) is used to power the VDDSHV5 IO power rail, which will ramp-up and ramp-down along with the VDDA_3P3_SDIO power rail.
- (9) VDDS_DDR and VDDS_DDR_C are expected to be powered by the same source such that they ramp together.
- (10) VDD_CORE, VDDA_0P85_USB0, VDDA_0P85_SERDES0, VDDA_0P85_SERDES0_C, VDD_MMC0, VDDA_DLL_MMC0, and VDDR_CORE are expected to be powered by the same 0.85V source such that they ramp together.
- (11) VPP is the 1.8V eFuse programming supply, which shall be left floating (HiZ) or grounded during power-up/down sequences and during normal device operation. This supply shall only be sourced while programming eFuse.

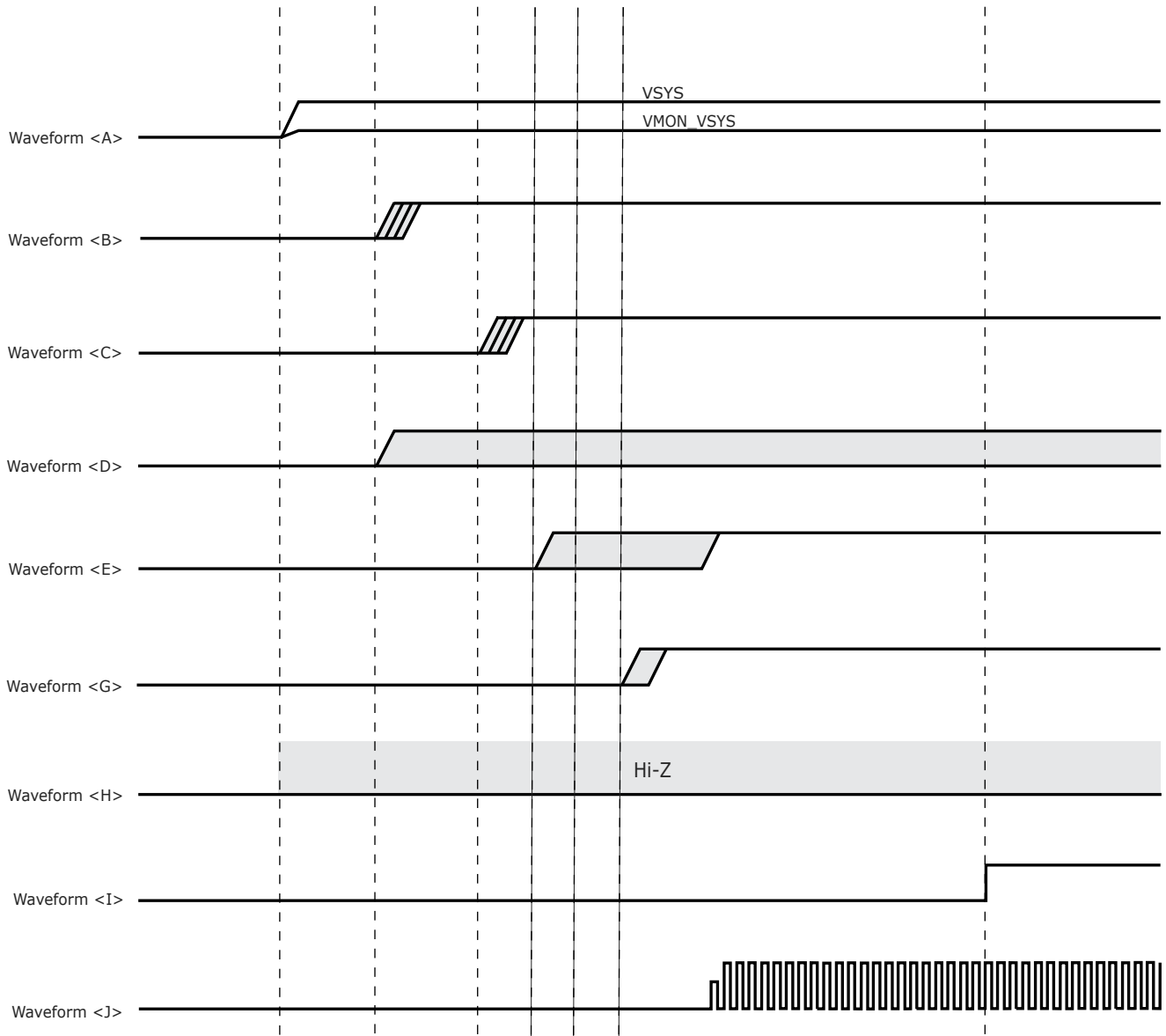

AM243x_ELCH_01

Figure 6-5. Power-Up Sequencing

6.11.2.2.2 Power-Down Sequencing

Table 6-6 and Figure 6-6 describe the device power-down sequencing.

Note

All power rails must be turned off and decay below 300mV before initiating a new power-up sequence anytime a power rail drops below the minimum value defined in *Recommended Operating Conditions*.

Table 6-6. Power-Down Sequencing – Supply / Signal Assignments

See: Figure 6-6

| WAVEFORM | SUPPLY / SIGNAL NAME |
|----------|---|
| A | VSYS, VMON_VSYS |
| B | VDDSHV_MCU ⁽¹⁾ , VDDSHV0 ⁽¹⁾ , VDDSHV1 ⁽¹⁾ , VDDSHV2 ⁽¹⁾ , VDDSHV3 ⁽¹⁾ , VDDSHV4 ⁽¹⁾ , VDDA_3P3_USB0, VMON_3P3_SOC, VMON_3P3_MCU |
| C | VDDSHV_MCU ⁽²⁾ , VDDSHV0 ⁽²⁾ , VDDSHV1 ⁽²⁾ , VDDSHV2 ⁽²⁾ , VDDSHV3 ⁽²⁾ , VDDSHV4 ⁽²⁾ , VDDA_MCU, VDDS_OSC, VDDA_ADC0, VDDA_PLL0, VDDA_PLL1, VDDA_PLL2, VDDA_1P8_SERDES0, VDDA_1P8_USB0, VMON_1P8_SOC, VMON_1P8_MCU, VDDA_TEMP0, VDDA_TEMP1, VDDS_MMC0 |
| D | VDDA_3P3_SDIO ^{(3) (4)} , VDDSHV5 ⁽³⁾ |
| E | VDDS_DDR ⁽⁵⁾ , VDDS_DDR_C ⁽⁵⁾ |
| G | VDD_CORE ⁽⁶⁾ , VDDA_0P85_USB0 ⁽⁶⁾ , VDDA_0P85_SERDES0 ⁽⁶⁾ , VDDA_0P85_SERDES0_C ⁽⁶⁾ , VDD_MMC0 ⁽⁶⁾ , VDDA_DLL_MMC0 ⁽⁶⁾ , VDDR_CORE ⁽⁶⁾ |
| H | VPP |
| I | MCU_PORz |
| J | MCU_OSC0_XI, MCU_OSC0_XO |

- (1) VDDSHV_MCU and VDDSHVx [x=0-4] when operating at 3.3V.
- (2) VDDSHV_MCU and VDDSHVx [x=0-4] when operating at 1.8V.
- (3) VDDA_3P3_SDIO was designed to support power-up or power-down without any dependency on other power rails. VDDSHV5 is a dual voltage IO supply that was designed to support power-up, power-down, or dynamic voltage change without any dependency on other power rails. This capability is required to support UHS-I SD Cards.
- (4) VDDA_3P3_SDIO is the 3.3V power rail for the internal SDIO_LDO. This power rail must be sourced from the same 3.3V power supply that provides power to a UHS-I SD Card connected to MMC1, which allows the MMC1 IOs and the SD Card IOs to power-up and power-down at the same time when the SD Card power supply is powered off to reset the SD Card. For this use case the SDIO_LDO output (CAP_VDDSHV_MMC1) is used to power the VDDSHV5 IO power rail, which will ramp-up and ramp-down along with the VDDA_3P3_SDIO power rail.
- (5) VDDS_DDR and VDDS_DDR_C are expected to be powered by the same source such that they ramp together.
- (6) VDD_CORE, VDDA_0P85_USB0, VDDA_0P85_SERDES0, VDDA_0P85_SERDES0_C, VDD_MMC0, VDDA_DLL_MMC0, and VDDR_CORE are expected to be powered by the same 0.85V source such that they ramp together.

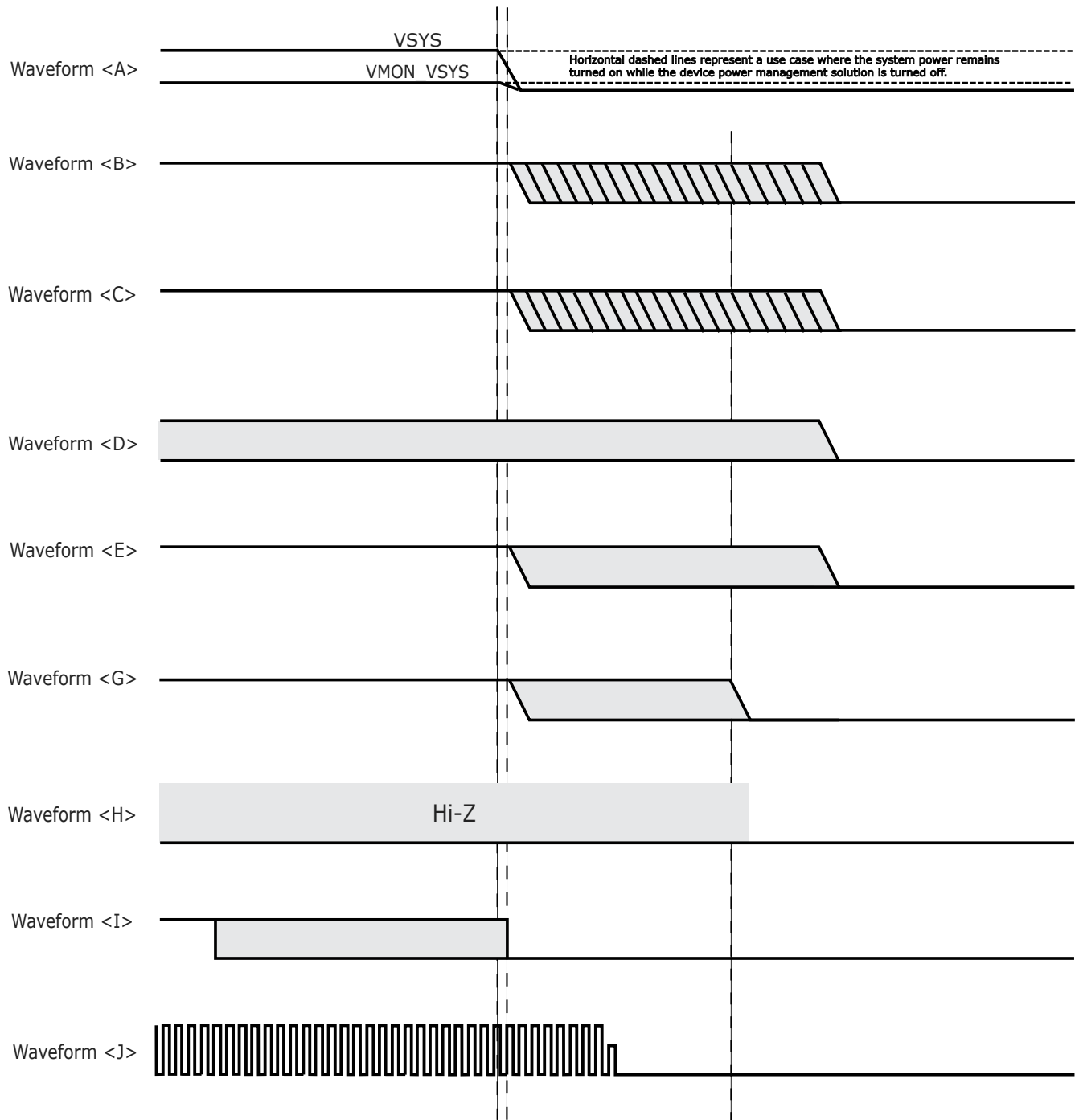

AM243x_BLOCK_02

Figure 6-6. Power-Down Sequencing

6.11.3 System Timing

For more details about features and additional description information on the subsystem multiplexing signals, see the corresponding subsections within *Signal Descriptions* and *Detailed Description* sections.

6.11.3.1 Reset Timing

Tables and figures provided in this section define timing conditions, timing requirements, and switching characteristics for reset related signals.

Table 6-7. Reset Timing Conditions

| PARAMETER | | MIN | MAX | UNIT |
|--------------------------|-------------------------|---------------------------|--------|------|
| INPUT CONDITIONS | | | | |
| SR _i | Input slew rate | VDD ⁽¹⁾ = 1.8V | 0.0018 | V/ns |
| | | VDD ⁽¹⁾ = 3.3V | 0.0033 | V/ns |
| OUTPUT CONDITIONS | | | | |
| C _L | Output load capacitance | | 30 | pF |

(1) VDD stands for corresponding power supply. For more information on the power supply name and the corresponding ball(s), see POWER column of the *Pin Attributes* table.

Table 6-8. MCU_PORz Timing Requirements

see [Figure 6-7](#)

| NO. | PARAMETER | MIN | MAX | UNIT |
|------|---|---------|-----|------|
| RST1 | Hold time, MCU_PORz active (low) at Power-up after supplies valid (using external crystal circuit) | 9500000 | | ns |
| RST2 | t _h (SUPPLIES_VALID - MCU_PORz) Hold time, MCU_PORz active (low) at Power-up after supplies valid and external clock stable (using external LVC MOS clock source) | 1200 | | ns |
| RST3 | t _w (MCU_PORzL) Pulse Width, MCU_PORz low after Power-up (without removal of Power or system reference clock MCU_OSC0_XI/XO) | 1200 | | ns |

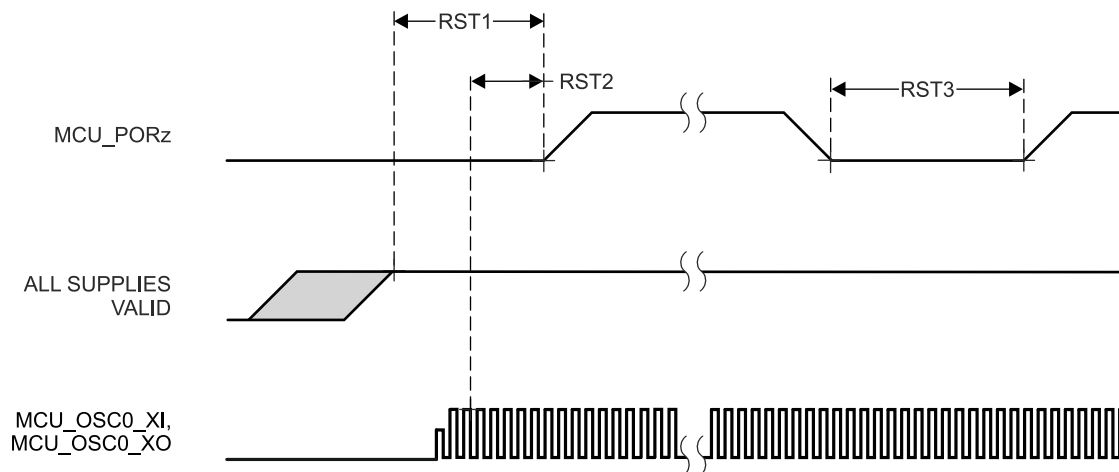

Figure 6-7. MCU_PORz Timing Requirements

Table 6-9. MCU_RESETSTATz, and RESETSTATz Switching Characteristics

see [Figure 6-8](#)

| NO. | PARAMETER | MIN | MAX | UNIT |
|------|--|----------------------|-----|------|
| RST4 | $t_{d(MCU_PORzL-MCU_RESETSTATzL)}$ Delay time, MCU_PORz active (low) to MCU_RESETSTATz active (low) | 0 | | ns |
| RST5 | $t_{d(MCU_PORzH-MCU_RESETSTATzH)}$ Delay time, MCU_PORz inactive (high) to MCU_RESETSTATz inactive (high) | $6120 \cdot S^{(1)}$ | | ns |
| RST6 | $t_{d(MCU_PORzL-RESETSTATzL)}$ Delay time, MCU_PORz active (low) to RESETSTATz active (low) | 0 | | ns |
| RST7 | $t_{d(MCU_PORzH-RESETSTATzH)}$ Delay time, MCU_PORz inactive (high) to RESETSTATz inactive (high) | $9195 \cdot S^{(1)}$ | | ns |
| RST8 | $t_{w(MCU_RESETSTATzL)}$ Pulse Width, MCU_RESETSTATz low (SW_MCU_WARMRST) | $966 \cdot S^{(1)}$ | | ns |
| RST9 | $t_{w(RESETSTATzL)}$ Pulse Width, RESETSTATz low (SW_MCU_WARMRST, SW_MAIN_PORz, or SW_MAIN_WARMRST) | $4040 \cdot S$ | | ns |

(1) S = MCU_OSC0_XI/XO clock period in ns.

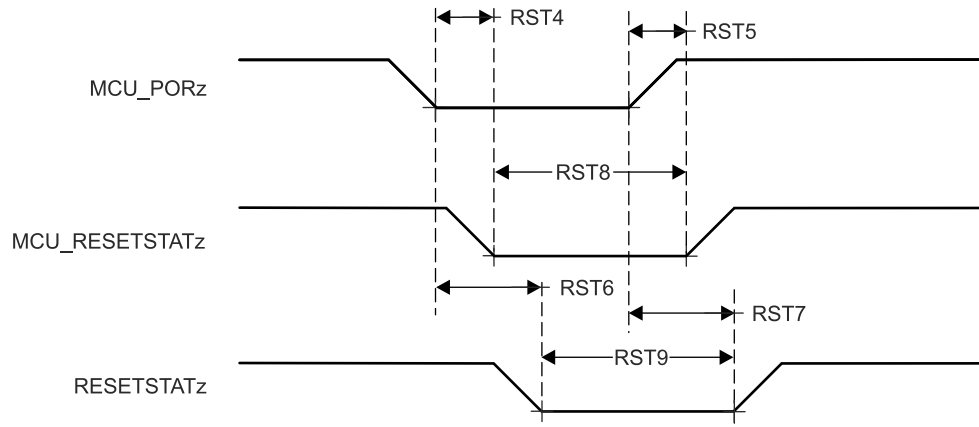

Figure 6-8. MCU_RESETSTATz, and RESETSTATz Switching Characteristics

Table 6-10. MCU_RESETz Timing Requirements

see Figure 6-9

| NO. | PARAMETER | MIN | MAX | UNIT |
|-------|--------------------------------------|------|-----|------|
| RST10 | $t_{w(MCU_RESETzL)}$ ⁽¹⁾ | 1200 | | ns |

(1) This timing parameter is valid only after all supplies are valid and MCU_PORz has been asserted for the specified time.

Table 6-11. MCU_RESETSTATz, and RESETSTATz Switching Characteristics

see Figure 6-9

| NO. | PARAMETER | MIN | MAX | UNIT |
|-------|--|-----------------------|-----|------|
| RST11 | $t_{d(MCU_RESETzL-MCU_RESETSTATzL)}$ | 0 | | ns |
| RST12 | $t_{d(MCU_RESETzH-MCU_RESETSTATzH)}$ | 966*S ⁽¹⁾ | | ns |
| RST13 | $t_{d(MCU_RESETzL-RESETSTATzL)}$ | 960 | | ns |
| RST14 | $t_{d(MCU_RESETzH-RESETSTATzH)}$ | 4040*S ⁽¹⁾ | | ns |

(1) S = MCU_OSC0_XI/XO clock period in ns.

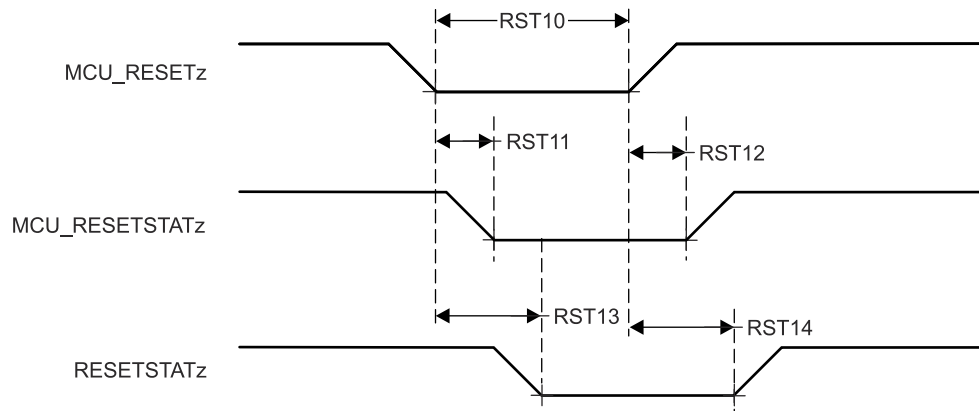

Figure 6-9. MCU_RESETz, MCU_RESETSTATz, and RESETSTATz Timing Requirements and Switching Characteristics

Table 6-12. RESET_REQz Timing Requirements

see [Figure 6-10](#)

| NO. | PARAMETER | MIN | MAX | UNIT |
|-------|---------------------------------------|------|-----|------|
| RST15 | $t_{w(RESSET_REQzL)}$ ⁽¹⁾ | 1200 | | ns |

(1) This timing parameter is valid only after all supplies are valid and MCU_PORz has been asserted for the specified time.

Table 6-13. RESETSTATz Switching Characteristics

see [Figure 6-10](#)

| NO. | PARAMETER | MIN | MAX | UNIT |
|-------|------------------------------------|----------------------|-----|------|
| RST16 | $t_{d(RESSET_REQzL-RESETSTATzL)}$ | $900 \cdot T^{(1)}$ | | ns |
| RST17 | $t_{d(RESSET_REQzH-RESETSTATzH)}$ | $4040 \cdot S^{(2)}$ | | ns |

(1) T = Reset Isolation Time (Software Dependent)

(2) S = MCU_OSC0_XI/XO clock period in ns.

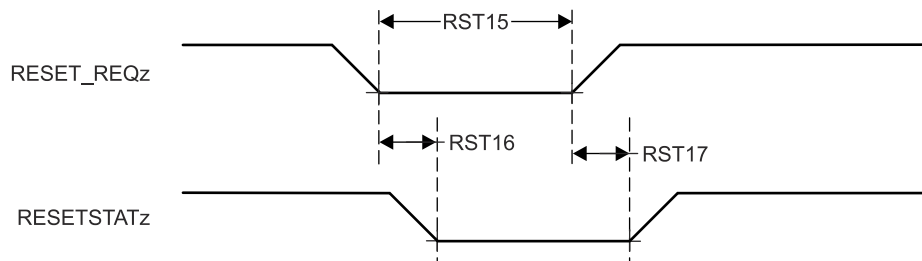

Figure 6-10. RESET_REQz and RESETSTATz Timing Requirements and Switching Characteristics

Table 6-14. EMUx Timing Requirements

see [Figure 6-11](#)

| NO. | PARAMETER | MIN | MAX | UNIT |
|-------|---------------------------|-------------------|-----|------|
| RST18 | $t_{su(EMUx-MCU_PORz)}$ | $3 \cdot S^{(1)}$ | | ns |
| RST19 | $t_{h(MCU_PORz - EMUx)}$ | 10 | | ns |

(1) S = MCU_OSC0_XI/XO clock period in ns.

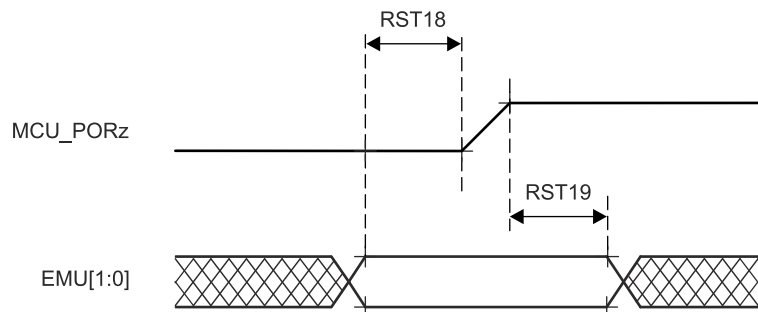

Figure 6-11. EMUx Timing Requirements

Table 6-15. BOOTMODE Timing Requirements

see Figure 6-12

| NO. | PARAMETER | MIN | MAX | UNIT |
|-------|--|-------------------|-----|------|
| RST23 | $t_{su}(\text{BOOTMODE-PORz_OUT})$ Setup time, BOOTMODE[15:00] valid before PORz_OUT high (External MCU PORz event or Software SW_MAIN_PORz) | $3 \cdot S^{(1)}$ | | ns |
| RST24 | $t_h(\text{PORz_OUT - BOOTMODE})$ Hold time, BOOTMODE[15:00] valid after PORz_OUT high (External MCU PORz event, or Software SW_MAIN_PORz) | 0 | | ns |

(1) S = MCU_OSC0_XI/XO clock period in ns.

Table 6-16. PORz_OUT Switching Characteristics

see Figure 6-12

| NO. | PARAMETER | MIN | MAX | UNIT |
|-------|--|------|-----|------|
| RST25 | $t_d(\text{MCU_PORzL-PORz_OUT})$ Delay time, MCU_PORz active (low) to PORz_OUT active (low) | 0 | | ns |
| RST26 | $t_d(\text{MCU_PORzH-PORz_OUT})$ Delay time, MCU_PORz inactive (high) to PORz_OUT inactive (high) | 1840 | | ns |
| RST27 | $t_w(\text{PORz_OUTL})$ Pulse Width, PORz_OUT low (MCU_PORz or SW_MAIN_PORz) | 1200 | | ns |

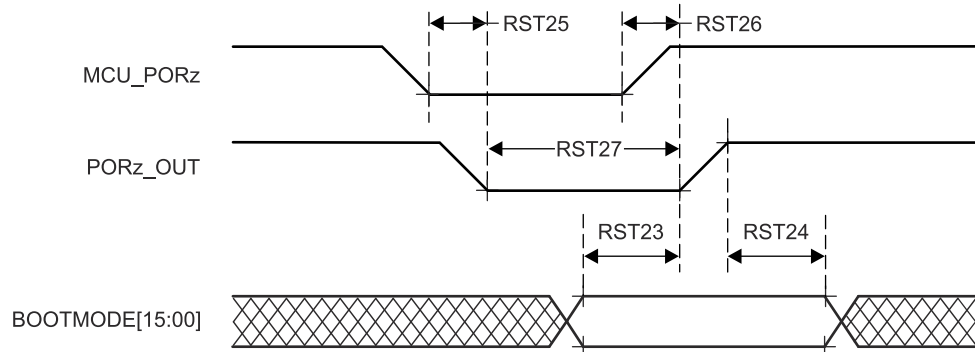

Figure 6-12. BOOTMODE Timing Requirements and PORz_OUT Switching Characteristics

6.11.3.2 Safety Signal Timing

Tables and figures provided in this section define timing conditions and switching characteristics for MCU_SAFETY_ERRORn.

Table 6-17. MCU_SAFETY_ERRORn Timing Conditions

| PARAMETER | | MIN | MAX | UNIT |
|--------------------------|-------------------------|-----|-----|------|
| OUTPUT CONDITIONS | | | | |
| C _L | Output load capacitance | | 30 | pF |

Table 6-18. MCU_SAFETY_ERRORn Switching Characteristics

see [Figure 6-13](#)

| NO. | PARAMETER | MIN | MAX | UNIT |
|-------|--|------------------------------------|-----|------|
| SFTY1 | t _c (MCU_SAFETY_ERRORn) Cycle time minimum, MCU_SAFETY_ERRORn (PWM mode enabled) | (P*H)+(P*L) ^{(1) (3) (4)} | | ns |
| SFTY2 | t _w (MCU_SAFETY_ERRORn) Pulse width minimum, MCU_SAFETY_ERRORn active (PWM mode disabled) ⁽⁵⁾ | P*R ^{(1) (2)} | | ns |
| SFTY3 | t _d (ERROR_CONDITION- MCU_SAFETY_ERRORnL) Delay time, ERROR CONDITION to MCU_SAFETY_ERRORn active ⁽⁵⁾ | 50*P ⁽¹⁾ | | ns |

- (1) P = ESM functional clock
- (2) R = Error Pin Counter Pre-Load Register count value
- (3) H = Error Pin PWM High Pre-Load Register count value
- (4) L = Error Pin PWM Low Pre-Load Register count value
- (5) When PWM mode is enabled, MCU_SAFETY_ERRORn stops toggling after SFTY3 and will maintain its value (either high or low) until the error is cleared. When PWM mode is disabled, MCU_SAFETY_ERRORn is active low.

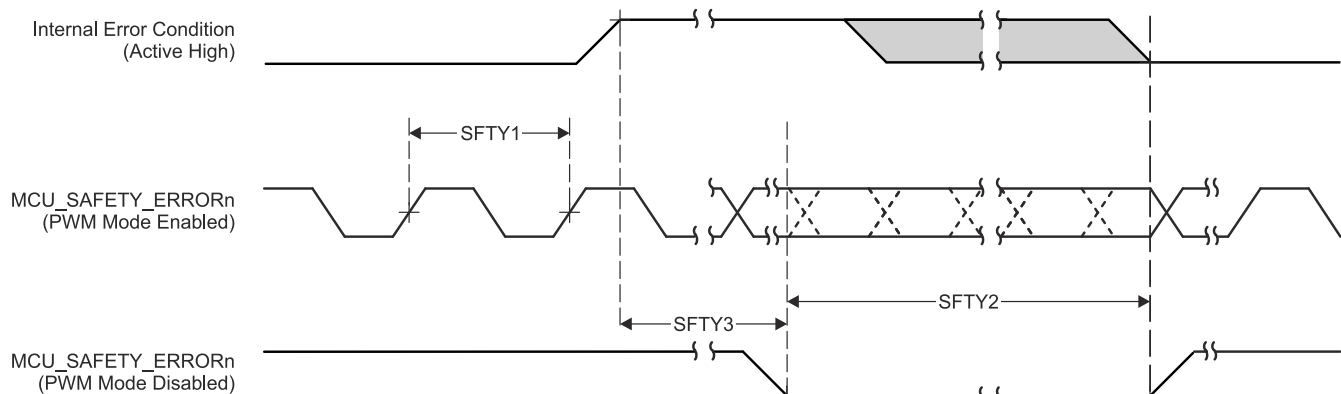

Figure 6-13. MCU_SAFETY_ERRORn Timing Requirements and Switching Characteristics

6.11.3.3 Clock Timing

Tables and figures provided in this section define timing conditions, timing requirements, and switching characteristics for clock signals.

Table 6-19. Clock Timing Conditions

| PARAMETER | | MIN | MAX | UNIT |
|--------------------------|-------------------------|------------------------------|-----|-------|
| INPUT CONDITIONS | | | | |
| SR _I | Input slew rate | 0.5 | | V/ns |
| OUTPUT CONDITIONS | | | | |
| C _L | Output load capacitance | 10ns ≤ t _c < 20ns | | 10 pF |
| | | 20ns ≤ t _c | | 30 pF |

Table 6-20. Clock Timing Requirements

see [Figure 6-14](#)

| NO. | | | MIN | MAX | UNIT |
|------|-----------------------------------|--------------------------------------|-----------------------|-----------------------|------|
| CLK1 | t _c (EXT_REFCLK1) | Cycle time minimum, EXT_REFCLK1 | 10 | | ns |
| CLK2 | t _w (EXT_REFCLK1H) | Pulse Duration, EXT_REFCLK1 high | E*0.45 ⁽¹⁾ | E*0.55 ⁽¹⁾ | ns |
| CLK3 | t _w (EXT_REFCLK1L) | Pulse Duration, EXT_REFCLK1 low | E*0.45 ⁽¹⁾ | E*0.55 ⁽¹⁾ | ns |
| CLK1 | t _c (MCU_EXT_REFCLK0) | Cycle time minimum, MCU_EXT_REFCLK0 | 10 | | ns |
| CLK2 | t _w (MCU_EXT_REFCLK0H) | Pulse Duration, MCU_EXT_REFCLK0 high | F*0.45 ⁽²⁾ | F*0.55 ⁽²⁾ | ns |
| CLK3 | t _w (MCU_EXT_REFCLK0L) | Pulse Duration, MCU_EXT_REFCLK0 low | F*0.45 ⁽²⁾ | F*0.55 ⁽²⁾ | ns |

- (1) E = EXT_REFCLK1 cycle time
- (2) F = MCU_EXT_REFCLK0 cycle time

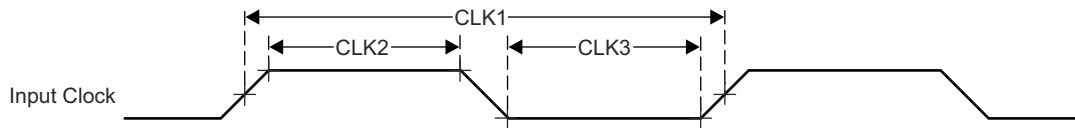

Figure 6-14. Clock Timing Requirements

Table 6-21. Clock Switching Characteristics

see [Figure 6-15](#)

| NO. | PARAMETER | | MIN | MAX | UNIT |
|------|----------------------------|--------------------------------------|----------------|----------------|------|
| CLK4 | $t_{c(SYSCCLKOUT0)}$ | Cycle time minimum, SYSCCLKOUT0 | 8 | | ns |
| CLK5 | $t_{w(SYSCCLKOUT0H)}$ | Pulse Duration, SYSCCLKOUT0 high | $A*0.4^{(1)}$ | $A*0.6^{(1)}$ | ns |
| CLK6 | $t_{w(SYSCCLKOUT0L)}$ | Pulse Duration, SYSCCLKOUT0 low | $A*0.4^{(1)}$ | $A*0.6^{(1)}$ | ns |
| CLK4 | $t_{c(OBSCLK0)}$ | Cycle time minimum, OBSCLK0 | 5 | | ns |
| CLK5 | $t_{w(OBSCLK0H)}$ | Pulse Duration, OBSCLK0 high | $B*0.45^{(2)}$ | $B*0.55^{(2)}$ | ns |
| CLK6 | $t_{w(OBSCLK0L)}$ | Pulse Duration, OBSCLK0 low | $B*0.45^{(2)}$ | $B*0.55^{(2)}$ | ns |
| CLK4 | $t_{c(CLKOUT0)}$ | Cycle time minimum, CLKOUT0 | 20 | | ns |
| CLK5 | $t_{w(CLKOUT0H)}$ | Pulse Duration, CLKOUT0 high | $C*0.4^{(3)}$ | $C*0.6^{(3)}$ | ns |
| CLK6 | $t_{w(CLKOUT0L)}$ | Pulse Duration, CLKOUT0 low | $C*0.4^{(3)}$ | $C*0.6^{(3)}$ | ns |
| CLK4 | $t_{c(MCU_SYSCCLKOUT0)}$ | Cycle time minimum, MCU_SYSCCLKOUT0 | 10 | | ns |
| CLK5 | $t_{w(MCU_SYSCCLKOUT0H)}$ | Pulse Duration, MCU_SYSCCLKOUT0 high | $G*0.4^{(4)}$ | $G*0.6^{(4)}$ | ns |
| CLK6 | $t_{w(MCU_SYSCCLKOUT0L)}$ | Pulse Duration, MCU_SYSCCLKOUT0 low | $G*0.4^{(4)}$ | $G*0.6^{(4)}$ | ns |
| CLK4 | $t_{c(MCU_OBSCLK0)}$ | Cycle time minimum, MCU_OBSCLK0 | 5 | | ns |
| CLK5 | $t_{w(MCU_OBSCLK0H)}$ | Pulse Duration, MCU_OBSCLK0 high | $H*0.45^{(5)}$ | $H*0.55^{(5)}$ | ns |
| CLK6 | $t_{w(MCU_OBSCLK0L)}$ | Pulse Duration, MCU_OBSCLK0 low | $H*0.45^{(5)}$ | $H*0.55^{(5)}$ | ns |

- (1) A = SYSCCLKOUT0 cycle time
- (2) B = OBSCLK0 cycle time
- (3) C = CLKOUT0 cycle time
- (4) G = MCU_SYSCCLKOUT0 cycle time
- (5) H = MCU_OBSCLK0 cycle time

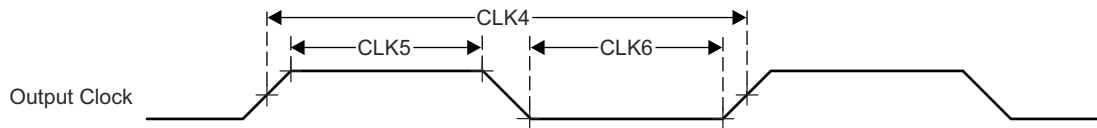

Figure 6-15. Clock Switching Characteristics

6.11.4 Clock Specifications

6.11.4.1 Input Clocks / Oscillators

Various external clock inputs/outputs are needed to drive the device. Summary of these input clock signals is as follows:

- MCU_OSC0_XI/MCU_OSC0_XO — External main crystal interface pins connected to the internal high-frequency oscillator (MCU_HFOSC0), which is the default clock source for internal reference clock MCU_HFOSC0_CLKOUT.
- General purpose clock inputs
 - MCU_EXT_REFCLK0 — Optional external system clock input for MCU domain.
 - EXT_REFCLK1 — Optional external system clock input for MAIN domain.
 - SERDES0_REFCLK0P/N — Optional SERDES0 reference clock input for PCIe.
- External CPTS reference clock inputs
 - CP_GEMAC_CPTS0_RFT_CLK — CPTS reference clock input.
 - CPTS_RFT_CLK — CPTS reference clock input.

Figure 6-16 shows the external input clock sources and the output clocks to peripherals.

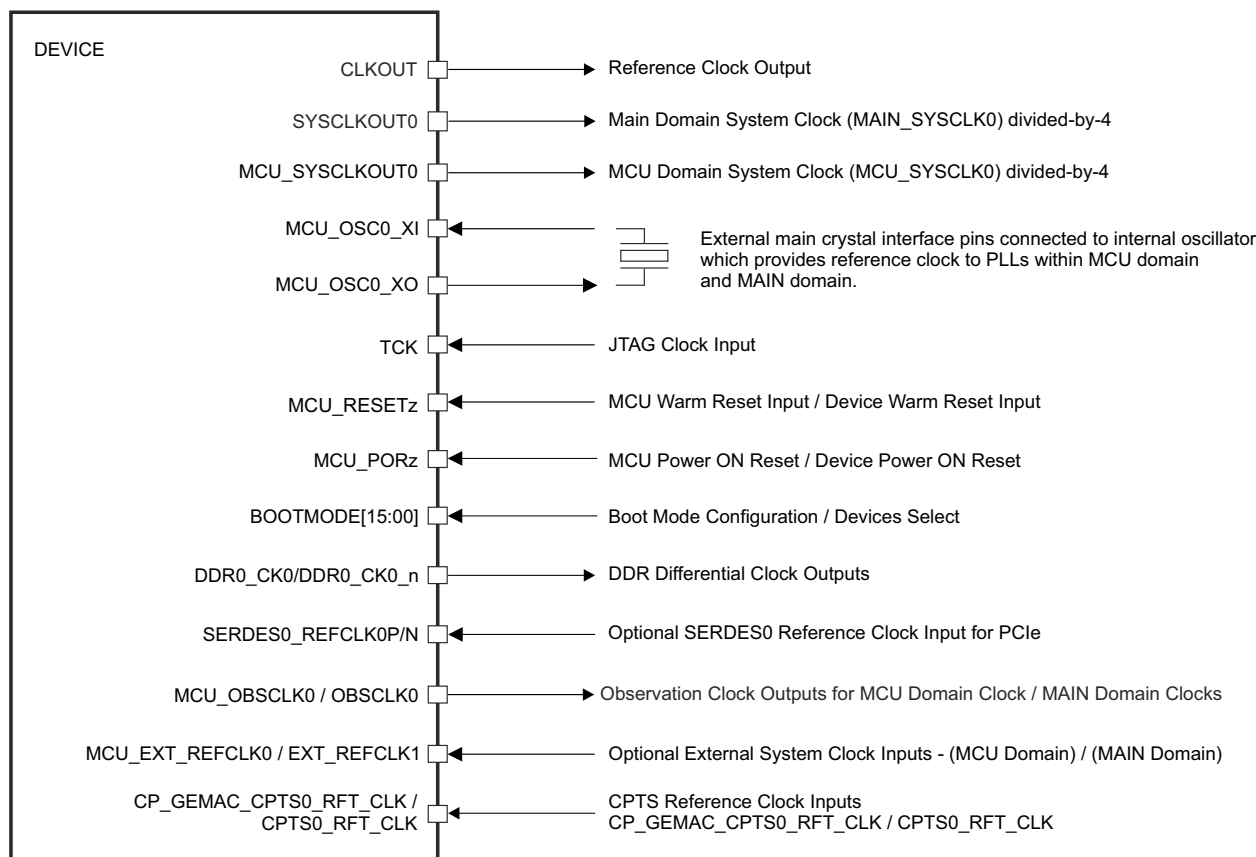
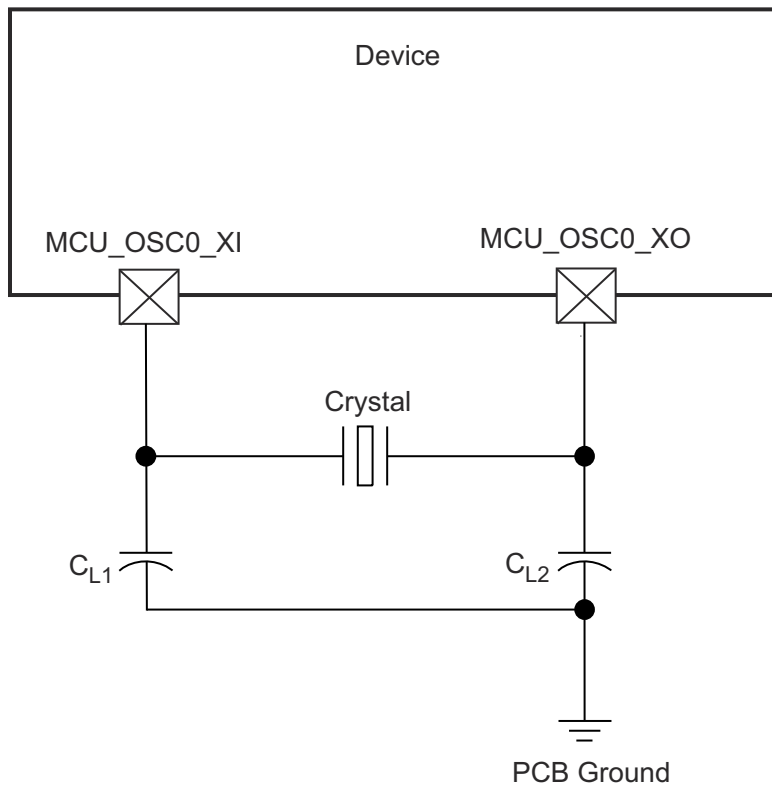

Figure 6-16. Input Clocks Interface

For more information about Input clock interfaces, see *Clocking* section in *Device Configuration* chapter in the device TRM.

6.11.4.1.1 MCU_OSC0 Internal Oscillator Clock Source

Figure 6-17 shows the recommended crystal circuit. All discrete components used to implement the oscillator circuit must be placed as close as possible to the MCU_OSC0_XI and MCU_OSC0_XO pins.



AM55x_MCU_OSC_INT_01

Figure 6-17. MCU_OSC0 Crystal Implementation

The crystal must be in the fundamental mode of operation and parallel resonant. Table 6-22 summarizes the required electrical constraints.

Table 6-22. MCU_OSC0 Crystal Circuit Requirements

| PARAMETER | | MIN | TYP | MAX | UNIT | |
|--------------------------------|---|---|-------|------|------|----|
| F _{x_{tal}} | Crystal Parallel Resonance Frequency | | 25 | | MHz | |
| F _{x_{tal}} | Crystal Frequency Stability and Tolerance | Ethernet RGMII and RMII not used | | ±100 | ppm | |
| | | Ethernet RGMII and RMII using derived clock | | ±50 | | |
| C _{L1+PCBXI} | Capacitance of C _{L1} + C _{PCBXI} | 12 | | 24 | pF | |
| C _{L2+PCBXO} | Capacitance of C _{L2} + C _{PCBXO} | 12 | | 24 | pF | |
| C _L | Crystal Load Capacitance | 6 | | 12 | pF | |
| C _{shunt} | Crystal Circuit Shunt Capacitance | ESR _{x_{tal}} = 30 Ω | 25MHz | | 7 | pF |
| | | ESR _{x_{tal}} = 40 Ω | 25MHz | | 5 | pF |
| | | ESR _{x_{tal}} = 50 Ω | 25MHz | | 5 | pF |
| ESR _{x_{tal}} | Crystal Effective Series Resistance | | | (1) | Ω | |

(1) The maximum ESR of the crystal is a function of the crystal frequency and shunt capacitance. See the C_{shunt} parameter.

When selecting a crystal, the system design must consider temperature and aging characteristics of the crystal based on worst case environment and expected life expectancy of the system.

Table 6-23 details the switching characteristics of the oscillator.

Table 6-23. MCU_OSC0 Switching Characteristics - Crystal Mode

| PARAMETER | | PACKAGE | MIN | TYP | MAX | UNIT |
|-------------------|-----------------------------|---------|-----|-----|-------|------|
| C _{XI} | XI Capacitance | ALV | | | 1.44 | pF |
| C _{XO} | XO Capacitance | | | | 1.52 | pF |
| C _{XIXO} | XI to XO Mutual Capacitance | | | | 0.01 | pF |
| C _{XI} | XI Capacitance | ANI | | | 1.435 | pF |
| C _{XO} | XO Capacitance | | | | 1.472 | pF |
| C _{XIXO} | XI to XO Mutual Capacitance | | | | 0.01 | pF |
| C _{XI} | XI Capacitance | ALX | | | 0.812 | pF |
| C _{XO} | XO Capacitance | | | | 0.821 | pF |
| C _{XIXO} | XI to XO Mutual Capacitance | | | | 0.01 | pF |
| t _s | Start-up Time | | | 4 | | ms |

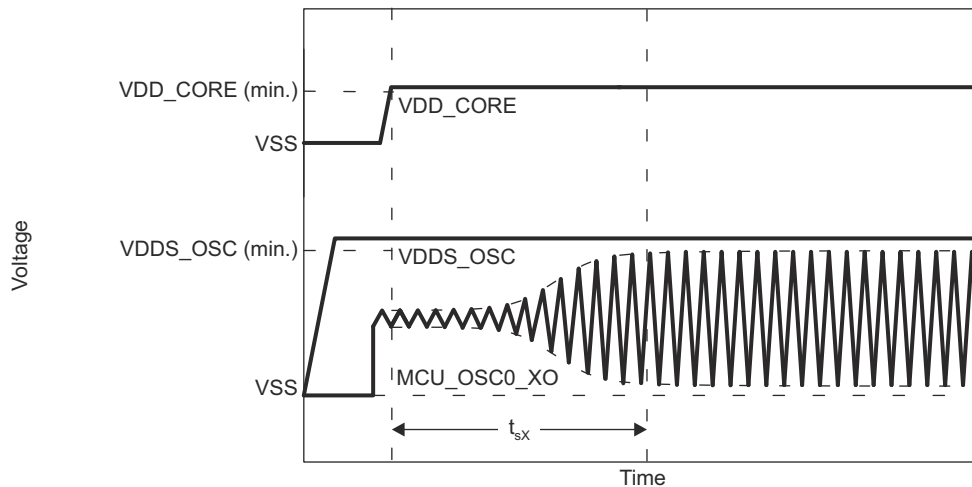

Figure 6-18. MCU_OSC0 Start-up Time

6.11.4.1.1 Load Capacitance

The crystal circuit must be designed such that it applies the appropriate capacitive load to the crystal, as defined by the crystal manufacturer. The capacitive load, C_L, of this circuit is a combination of discrete capacitors C_{L1}, C_{L2}, and several parasitic contributions. PCB signal traces which connect crystal circuit components to MCU_OSC0_XI and MCU_OSC0_XO have parasitic capacitance to ground, C_{PCBXI} and C_{PCBXO}, where the PCB designer should be able to extract parasitic capacitance for each signal trace. The MCU_OSC0 circuits and device package have combined parasitic capacitance to ground, C_{PCBXI} and C_{PCBXO}, where these parasitic capacitance values are defined in Table 6-23.

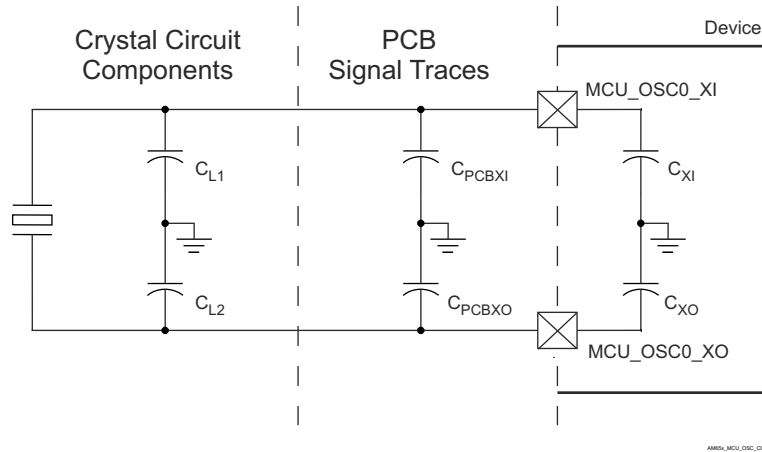

Figure 6-19. Load Capacitance

Load capacitors, C_{L1} and C_{L2} in [Figure 6-17](#), should be chosen such that the below equation is satisfied. C_L in the equation is the load specified by the crystal manufacturer.

$$C_L = [(C_{L1} + C_{PCB_{XI}} + C_{X1}) \times (C_{L2} + C_{PCB_{XO}} + C_{XO})] / [(C_{L1} + C_{PCB_{XI}} + C_{X1}) + (C_{L2} + C_{PCB_{XO}} + C_{XO})]$$

To determine the value of C_{L1} and C_{L2} , multiply the capacitive load value C_L by 2. Using this result, subtract the combined values of $C_{PCB_{XI}} + C_{X1}$ to determine the value of C_{L1} and the combined values of $C_{PCB_{XO}} + C_{XO}$ to determine the value of C_{L2} . For example, if $C_L = 10\text{pF}$, $C_{PCB_{XI}} = 2.9\text{pF}$, $C_{X1} = 0.5\text{pF}$, $C_{PCB_{XO}} = 3.7\text{pF}$, $C_{XO} = 0.5\text{pF}$, the value of $C_{L1} = [(2C_L) - (C_{PCB_{XI}} + C_{X1})] = [(2 \times 10\text{pF}) - 2.9\text{pF} - 0.5\text{pF}] = 16.6\text{pF}$ and $C_{L2} = [(2C_L) - (C_{PCB_{XO}} + C_{XO})] = [(2 \times 10\text{pF}) - 3.7\text{pF} - 0.5\text{pF}] = 15.8\text{pF}$

6.11.4.1.1.2 Shunt Capacitance

The crystal circuit must also be designed such that it does not exceed the maximum shunt capacitance for MCU_OSC0 operating conditions defined in [Table 6-22](#). Shunt capacitance, C_{shunt} , of the crystal circuit is a combination of crystal shunt capacitance and parasitic contributions. PCB signal traces which connect crystal circuit components to MCU_OSC0 have mutual parasitic capacitance to each other, $C_{PCB_{XIXO}}$, where the PCB designer should be able to extract mutual parasitic capacitance between these signal traces. The device package also has mutual parasitic capacitance, C_{XIXO} , where this mutual parasitic capacitance value is defined in [Table 6-23](#).

PCB routing should be designed to minimize mutual capacitance between XI and XO signal traces. This is typically done by keeping signal traces short and not routing them in close proximity. Mutual capacitance can also be minimized by placing a ground trace between these signals when the layout requires them to be routed in close proximity. It is important to minimize the mutual capacitance on the PCB to provide as much margin as possible when selecting a crystal.

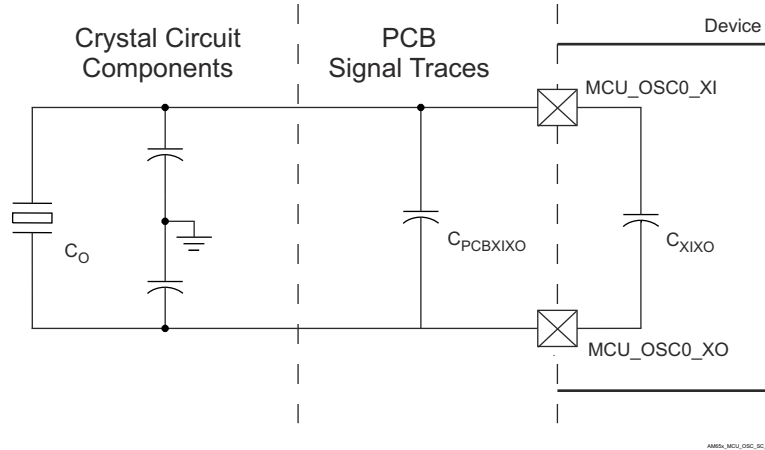

Figure 6-20. Shunt Capacitance

A crystal should be chosen such that the below equation is satisfied. C_O in the equation is the maximum shunt capacitance specified by the crystal manufacturer.

$$C_{shunt} \geq C_O + C_{PCBXIXO} + C_{XIXO}$$

For example, the equation would be satisfied when the crystal being used is 25MHz with an ESR = 30Ω, $C_{PCBXIXO} = 0.04\text{pF}$, $C_{XIXO} = 0.01\text{pF}$, and shunt capacitance of the crystal is less than or equal to 6.95pF.

6.11.4.1.2 MCU_OSC0 LVCMOS Digital Clock Source

Figure 6-21 shows the recommended oscillator connections when MCU_OSC0_XI is connected to a 1.8V LVCMOS square-wave digital clock source.

Note

1. A DC steady-state condition is not allowed on MCU_OSC0_XI when the oscillator is powered up. This is not allowed because MCU_OSC0_XI is internally AC coupled to a comparator that can enter an unknown state when DC is applied to the input. Therefore, application software must power down MCU_OSC0 any time MCU_OSC0_XI is not toggling between logic states.
2. The PCB trace length connecting the LVCMOS clock source to MCU_OSC0_XI should be minimized. This reduces capacitive loading and decreases probability of external noise sources coupling into the clock signal. Reduced capacitive loading improves rise/fall times of the clock signal which reduces the probability of jitter being introduced in the system.
3. The LVCMOS clock signal sourcing the MCU_OSC0_XI input must have monotonic transitions. The clock source should be connected to MCU_OSC0_XI with a point-to-point connection, via a series termination resistor placed near the clock source. The series termination resistor value should match the clock source output impedance to the transmission line impedance. For example, the series termination resistor value needs to be 20 ohms if the clock source has an output impedance of 30 ohms and the PCB signal trace has a characteristic impedance of 50 ohms. This allows the reflection that returns from the far end of the un-terminated transmission line to be completely absorbed such that it does not introduce any non-monotonic events on the signal.

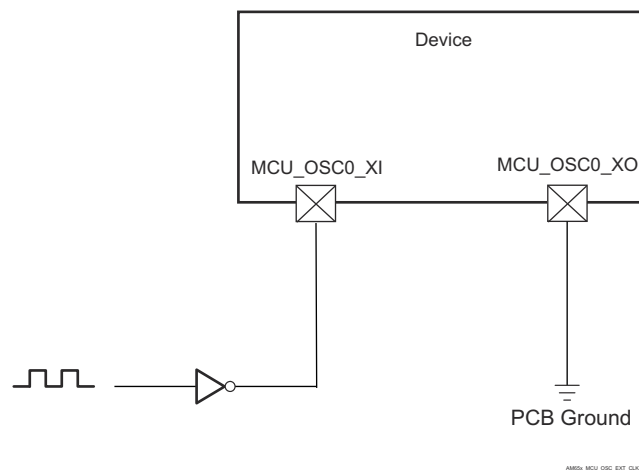

Figure 6-21. 1.8V LVCMOS-Compatible Clock Input

Table 6-24. MCU_OSC0 LVCMOS Digital Clock Source Requirements

| PARAMETER | | MIN | TYP | MAX | UNIT |
|----------------------------|---|---|-----|-------------------|--------|
| F _{xtal} | Frequency | | 25 | | MHz |
| | Frequency Stability and Tolerance | Ethernet RGMII and RMII not used | | ±100 | ppm |
| | | Ethernet RGMII and RMII using derived clock | | ±50 | |
| DC | Duty Cycle | 45 | | 55 | % |
| t _{R/F} | Rise/Fall Time (10%-90% rise, 90%-10% fall) | | | 4 ⁽¹⁾ | ns |
| J _{Period(RMS)} | Period Jitter, RMS (100k samples) | | | 20 | ps |
| J _{Period(PK-PK)} | Period Jitter, Peak to Peak (100k samples) | | | 300 | ps |
| J _{Phase(RMS)} | Phase Jitter, RMS (BW 100Hz to 1MHz) | | | 10 ⁽²⁾ | ps |
| PN | Phase Noise ⁽³⁾ | 100Hz | | -92.3 | dBc/Hz |
| | | 1kHz | | -112.3 | |
| | | 10kHz | | -132.3 | |
| | | 100kHz | | -142.3 | |
| | | 1MHz | | -152.3 | |

- (1) Most LVCMOS oscillator datasheets define their maximum Output Rise/Fall times with a capacitive load much larger than the actual load that will be applied by the combined PCB trace capacitance and MCU_OSC0_XI input capacitance. It should not be difficult to find a LVCMOS oscillator that meets this requirement. However, the system designer must confirm the LVCMOS oscillator selected will provide the appropriate rise/fall time to MCU_OSC0_XI input.
- (2) Most LVCMOS oscillator datasheets define their max RMS Phase Jitter using a larger bandwidth integration range than required by this device. To get a more appropriate value, it may be necessary to contact the LVCMOS oscillator manufacture and ask them to provide a maximum RMS Phase Jitter using the same bandwidth integration range that has been defined for this parameter.
- (3) The Phase Noise parameter is only applicable when the SerDes PHY is used for USB SuperSpeed, or PCIe operating without a common external clock source.

6.11.4.2 Output Clocks

The device provides several system clock outputs. Summary of these output clocks are as follows:

- **MCU_SYSCLKOUT0**
 - MCU_SYSCLKOUT0 is the MCU domain system clock (MCU_SYSCLK0) divided-by-4. This clock output is provided for test and debug purposes only.
- **MCU_OBSCLK0**
 - Observation clock output for test and debug purposes only.
- **SYSCLKOUT0**
 - SYSCLKOUT0 is the MAIN domain system clock (MAIN_SYSCLK0) divided-by-4. This clock output is provided for test and debug purposes only.
- **CLKOUT0**
 - CLKOUT0 is the Ethernet subsystem clock (MAIN_PLL0_HSDIV4_CLKOUT) divided-by-5 or divided-by-10. This clock output was provided to source to the external PHY. When configured to operate as the RMIIClock source (50MHz) the signal must also be routed back to the RMIICLK pin for proper device operation.
- **OBSCLK0**
 - Observation clock output for test and debug purposes only.
- **GPMC_FCLK_MUX**
 - GPMC_FCLK_MUX is the GPMC0 functional clock (GPMC_FCLK). This clock is provided as an alternative GPMC interface clock when attached devices require a continuous running clock.

For more information, see *Clock Outputs* section in *Clocking* chapter and *GPMC Clock Configuration* section in *Peripherals* chapter in the device TRM.

6.11.4.3 PLLs

Power is supplied to the Phase-Locked Loop circuits (PLLs) by internal regulators that derive their power from off-chip power-sources.

There is one PLL in the MCU domain:

- MCU_PLL0 (MCU PLL)

There are six PLLs in the MAIN domain:

- MAIN_PLL0 (MAIN PLL)
- MAIN_PLL1 (PER0 PLL)
- MAIN_PLL2 (PER1 PLL)
- MAIN_PLL8 (ARM0 PLL)
- MAIN_PLL12 (DDR PLL)
- MAIN_PLL14 (R5F PLL)

Note

For more information, see:

- *Device Configuration / Clocking / PLLs* section in the device TRM.
 - *Programmable Real-Time Unit Subsystem and Industrial Communication Subsystem - Gigabit (PRU_ICSSG)* section in the device TRM.
-

Note

The input reference clock (MCU_OSC0_XI / MCU_OSC0_XO) is specified and the lock time is ensured by the PLL controller, as documented in the *Device Configuration* chapter in the device TRM.

6.11.4.4 Recommended System Precautions for Clock and Control Signal Transitions

All clock and strobe signals must transition between V_{IH} and V_{IL} (or between V_{IL} and V_{IH}) in a monotonic manner.

Monotonic transitions are more likely to occur with fast signal transitions. It is easy for noise to create non-monotonic events on a signal with slow transitions. Therefore, avoid slow signal transitions on all clock and control signals since they are more likely to generate glitches inside the device.

6.11.5 Peripherals

6.11.5.1 CPSW3G

For more details about features and additional description information on the device Gigabit Ethernet MAC, see the corresponding subsections within *Signal Descriptions* and *Detailed Description* sections.

Note

CPSW3G MDIO0, CPSW3G RMII1, CPSW3G RMII2, and CPSW3G RGMII1 have one or more signals which can be multiplexed to more than one pin. Timing requirements and switching characteristics defined in this section are only valid for specific pin combinations known as IOSETs. Valid pin combinations or IOSETs for these interfaces can be found in the tables of the [CPSW3G IOSETs](#) section.

6.11.5.1.1 CPSW3G MDIO Timing

Table 6-25, Table 6-26, Table 6-27, and Figure 6-22 present timing conditions, timing requirements, and switching characteristics for CPSW3G MDIO.

Table 6-25. CPSW3G MDIO Timing Conditions

| PARAMETER | | MIN | MAX | UNIT |
|---------------------------------------|--|-----|-----|------|
| INPUT CONDITIONS | | | | |
| SR _I | Input slew rate | 0.9 | 3.6 | V/ns |
| OUTPUT CONDITIONS | | | | |
| C _L | Output load capacitance | 10 | 470 | pF |
| PCB CONNECTIVITY REQUIREMENTS | | | | |
| t _d (Trace Delay) | Propagation delay of each trace | 0 | 5 | ns |
| t _d (Trace Mismatch Delay) | Propagation delay mismatch across all traces | | 1 | ns |

Table 6-26. CPSW3G MDIO Timing Requirements

see Figure 6-22

| NO. | PARAMETER | | MIN | MAX | UNIT |
|-------|----------------------------|--|-----|-----|------|
| MDIO1 | t _{su} (MDIO_MDC) | Setup time, MDIO[x]_MDIO valid before MDIO[x]_MDC high | 45 | | ns |
| MDIO2 | t _h (MDC_MDIO) | Hold time, MDIO[x]_MDIO valid after MDIO[x]_MDC high | 0 | | ns |

Table 6-27. CPWS3G MDIO Switching Characteristics

see Figure 6-22

| NO. | PARAMETER | | MIN | MAX | UNIT |
|-------|---------------------------|---|-----|-----|------|
| MDIO3 | t _c (MDC) | Cycle time, MDIO[x]_MDC | 400 | | ns |
| MDIO4 | t _w (MDCH) | Pulse Duration, MDIO[x]_MDC high | 160 | | ns |
| MDIO5 | t _w (MDCL) | Pulse Duration, MDIO[x]_MDC low | 160 | | ns |
| MDIO7 | t _d (MDC_MDIO) | Delay time, MDIO[x]_MDC low to MDIO[x]_MDIO valid | -10 | 10 | ns |

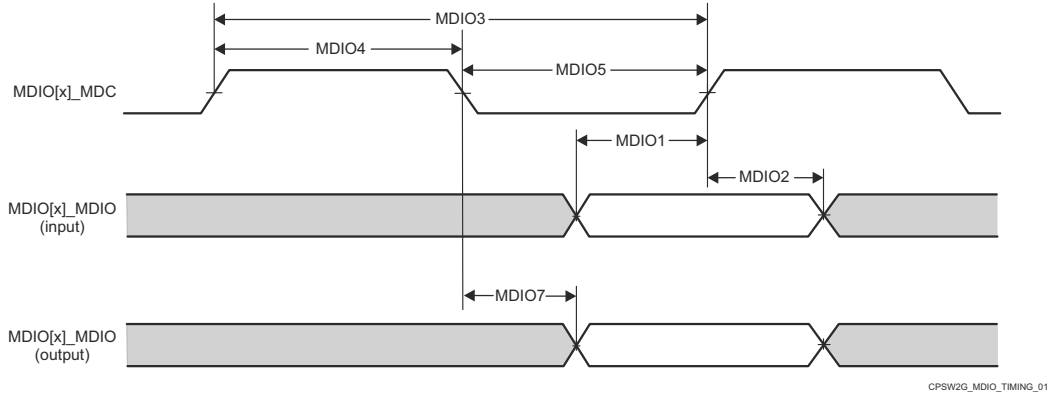

Figure 6-22. CPSW3G MDIO Timing Requirements and Switching Characteristics

6.11.5.1.2 CPSW3G RMII Timing

Table 6-28, Table 6-29, Figure 6-23, Table 6-30, Figure 6-24 Table 6-31, and Figure 6-25 present timing conditions, timing requirements, and switching characteristics for CPSW3G RMII.

Table 6-28. CPSW3G RMII Timing Conditions

| PARAMETER | | MIN | MAX | UNIT |
|--------------------------|-------------------------|---------------------------|------|--------|
| INPUT CONDITIONS | | | | |
| SR _i | Input slew rate | VDD ⁽¹⁾ = 1.8V | 0.18 | 5 V/ns |
| | | VDD ⁽¹⁾ = 3.3V | 0.4 | 5 V/ns |
| OUTPUT CONDITIONS | | | | |
| C _L | Output load capacitance | 3 | 25 | pF |

(1) VDD stands for corresponding power supply. For more information on the power supply name and the corresponding ball(s), see POWER column of the Pin Attributes table.

Table 6-29. RMII[x]_REF_CLK Timing Requirements – RMII Mode

see Figure 6-23

| NO. | PARAMETER | DESCRIPTION | MIN | MAX | UNIT |
|-------|--------------------------|--------------------------------------|--------|--------|------|
| RMII1 | t _{c(REF_CLK)} | Cycle time, RMII[x]_REF_CLK | 19.999 | 20.001 | ns |
| RMII2 | t _{w(REF_CLKH)} | Pulse Duration, RMII[x]_REF_CLK High | 7 | 13 | ns |
| RMII3 | t _{w(REF_CLKL)} | Pulse Duration, RMII[x]_REF_CLK Low | 7 | 13 | ns |

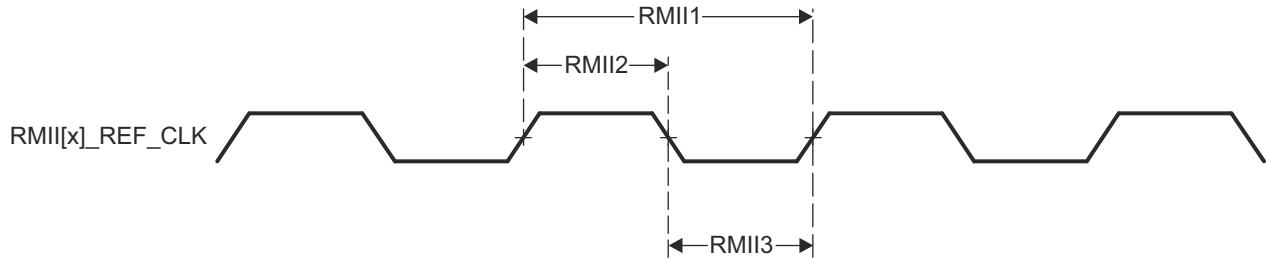

Figure 6-23. CPSW3G RMII[x]_REF_CLK Timing Requirements – RMII Mode

Table 6-30. RMII[x]_RXD[1:0], RMII[x]_CRS_DV, and RMII[x]_RX_ER Timing Requirements – RMII Mode

see Figure 6-24

| NO. | PARAMETER | DESCRIPTION | MIN | MAX | UNIT |
|-------|---------------------------------|---|-----|-----|------|
| RMII4 | t _{su(RXD-REF_CLK)} | Setup time, RMII[x]_RXD[1:0] valid before RMII[x]_REF_CLK | 4 | | ns |
| | t _{su(CRS_DV-REF_CLK)} | Setup time, RMII[x]_CRS_DV valid before RMII[x]_REF_CLK | 4 | | ns |
| | t _{su(RX_ER-REF_CLK)} | Setup time, RMII[x]_RX_ER valid before RMII[x]_REF_CLK | 4 | | ns |
| RMII5 | t _{h(REF_CLK-RXD)} | Hold time, RMII[x]_RXD[1:0] valid after RMII[x]_REF_CLK | 2 | | ns |
| | t _{h(REF_CLK-CRS_DV)} | Hold time, RMII[x]_CRS_DV valid after RMII[x]_REF_CLK | 2 | | ns |
| | t _{h(REF_CLK-RX_ER)} | Hold time, RMII[x]_RX_ER valid after RMII[x]_REF_CLK | 2 | | ns |

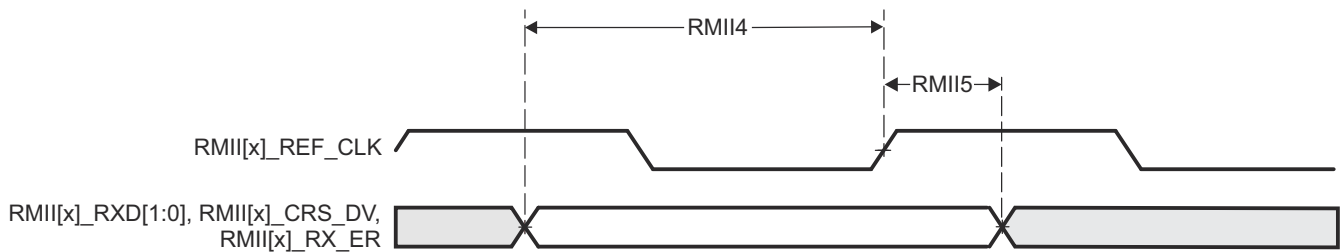

Figure 6-24. CPSW3G RMII[x]_RXD[1:0], RMII[x]_CRS_DV, RMII[x]_RX_ER Timing Requirements – RMII Mode

Table 6-31. RMII[x]_TXD[1:0], and RMII[x]_TX_EN Switching Characteristics – RMII Mode

see [Figure 6-25](#)

| NO. | PARAMETER | DESCRIPTION | MIN | MAX | UNIT |
|-------|---------------------------------|--|-----|-----|------|
| RMII6 | $t_{d(\text{REF_CLK-TXD})}$ | Delay time, RMII[x]_REF_CLK High to RMII[x]_TXD[1:0] valid | 2 | 10 | ns |
| | $t_{d(\text{REF_CLK-TX_EN})}$ | Delay time, RMII[x]_REF_CLK to RMII[x]_TX_EN valid | 2 | 10 | ns |

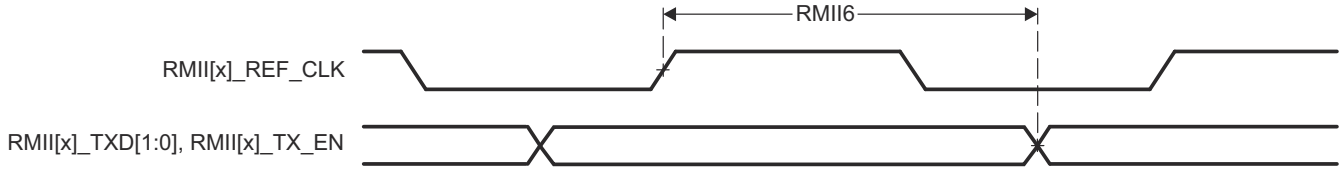

Figure 6-25. RMII[x]_TXD[1:0], and RMII[x]_TX_EN Switching Characteristics – RMII Mode

6.11.5.1.3 CPSW3G RGMII Timing

Table 6-32, Table 6-33, Table 6-34, Figure 6-26, Table 6-35, Table 6-36, and Figure 6-27 present timing conditions, timing requirements, and switching characteristics for CPSW3G RGMII.

Table 6-32. CPSW3G RGMII Timing Conditions

| PARAMETER | | | MIN | MAX | UNIT |
|---------------------------------------|--|--|------|-----|------|
| INPUT CONDITIONS | | | | | |
| SR _i | Input slew rate | VDD ⁽¹⁾ = 1.8V | 1.44 | 5 | V/ns |
| | | VDD ⁽¹⁾ = 3.3V | 2.64 | 5 | |
| OUTPUT CONDITIONS | | | | | |
| C _L | Output load capacitance | | 2 | 20 | pF |
| PCB CONNECTIVITY REQUIREMENTS | | | | | |
| t _d (Trace Mismatch Delay) | Propagation delay mismatch across all traces | RGMI[x]_RXC, RGMI[x]_RD[3:0], RGMI[x]_RX_CTL | | 50 | ps |
| | | RGMI[x]_TXC, RGMI[x]_TD[3:0], RGMI[x]_TX_CTL | | 50 | ps |

- (1) VDD stands for corresponding power supply. For more information on the power supply name and the corresponding ball(s), see POWER column of the *Pin Attributes* table.

Table 6-33. RGMII[x]_RXC Timing Requirements – RGMII Mode

see Figure 6-26

| NO. | PARAMETER | DESCRIPTION | MODE | MIN | MAX | UNIT |
|--------|---------------|-----------------------------------|----------|-----|-----|------|
| RGMII1 | $t_{c(RXC)}$ | Cycle time, RGMII[x]_RXC | 10Mbps | 360 | 440 | ns |
| | | | 100Mbps | 36 | 44 | ns |
| | | | 1000Mbps | 7.2 | 8.8 | ns |
| RGMII2 | $t_{w(RXCH)}$ | Pulse duration, RGMII[x]_RXC high | 10Mbps | 160 | 240 | ns |
| | | | 100Mbps | 16 | 24 | ns |
| | | | 1000Mbps | 3.6 | 4.4 | ns |
| RGMII3 | $t_{w(RXCL)}$ | Pulse duration, RGMII[x]_RXC low | 10Mbps | 160 | 240 | ns |
| | | | 100Mbps | 16 | 24 | ns |
| | | | 1000Mbps | 3.6 | 4.4 | ns |

Table 6-34. RGMII[x]_RD[3:0], and RGMII[x]_RX_CTL Timing Requirements – RGMII Mode

see Figure 6-26

| NO. | PARAMETER | DESCRIPTION | MODE | MIN | MAX | UNIT |
|--------|-----------------------|---|----------|-----|-----|------|
| RGMII4 | $t_{su(RD-RXC)}$ | Setup time, RGMII[x]_RD[3:0] valid before RGMII[x]_RXC high/low | 10Mbps | 1 | | ns |
| | | | 100Mbps | 1 | | ns |
| | | | 1000Mbps | 1 | | ns |
| | $t_{su(RX_CTL-RXC)}$ | Setup time, RGMII[x]_RX_CTL valid before RGMII[x]_RXC high/low | 10Mbps | 1 | | ns |
| | | | 100Mbps | 1 | | ns |
| | | | 1000Mbps | 1 | | ns |
| RGMII5 | $t_{h(RXC-RD)}$ | Hold time, RGMII[x]_RD[3:0] valid after RGMII[x]_RXC high/low | 10Mbps | 1 | | ns |
| | | | 100Mbps | 1 | | ns |
| | | | 1000Mbps | 1 | | ns |
| | $t_{h(RXC-RX_CTL)}$ | Hold time, RGMII[x]_RX_CTL valid after RGMII[x]_RXC high/low | 10Mbps | 1 | | ns |
| | | | 100Mbps | 1 | | ns |
| | | | 1000Mbps | 1 | | ns |

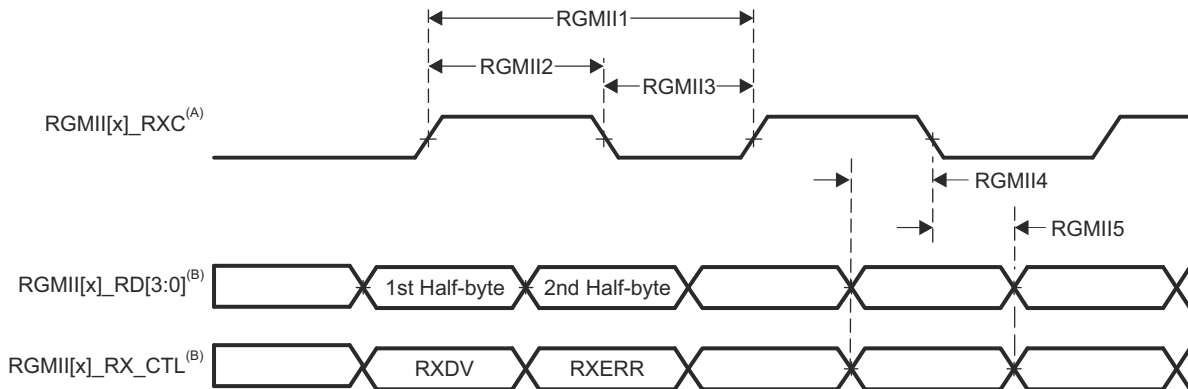

- A. RGMII[x]_RXC must be externally delayed relative to the data and control pins.
- B. Data and control information is received using both edges of the clocks. RGMII[x]_RD[3:0] carries data bits 3-0 on the rising edge of RGMII[x]_RXC and data bits 7-4 on the falling edge of RGMII[x]_RXC. Similarly, RGMII[x]_RX_CTL carries RXDV on rising edge of RGMII[x]_RXC and RXERR on falling edge of RGMII[x]_RXC.

Figure 6-26. CPSW3G RGMII[x]_RXC, RGMII[x]_RD[3:0], RGMII[x]_RX_CTL Timing Requirements - RGMII Mode

Table 6-35. RGMII[x]_TXC Switching Characteristics – RGMII Mode

see Figure 6-27

| NO. | PARAMETER | DESCRIPTION | MODE | MIN | MAX | UNIT |
|--------|--------------------|-----------------------------------|----------|-----|-----|------|
| RGMII6 | $t_c(\text{TXC})$ | Cycle time, RGMII[x]_TXC | 10Mbps | 360 | 440 | ns |
| | | | 100Mbps | 36 | 44 | ns |
| | | | 1000Mbps | 7.2 | 8.8 | ns |
| RGMII7 | $t_w(\text{TXCH})$ | Pulse duration, RGMII[x]_TXC high | 10Mbps | 160 | 240 | ns |
| | | | 100Mbps | 16 | 24 | ns |
| | | | 1000Mbps | 3.6 | 4.4 | ns |
| RGMII8 | $t_w(\text{TXCL})$ | Pulse duration, RGMII[x]_TXC low | 10Mbps | 160 | 240 | ns |
| | | | 100Mbps | 16 | 24 | ns |
| | | | 1000Mbps | 3.6 | 4.4 | ns |

Table 6-36. RGMII[x]_TD[3:0] and RGMII[x]_TX_CTL Switching Characteristics – RGMII Mode

see Figure 6-27

| NO. | PARAMETER | DESCRIPTION | MODE | MIN | MAX | UNIT |
|---------|-------------------------------------|--|----------|-----|-----|------|
| RGMII9 | $t_{\text{osu}}(\text{TD-TXC})$ | Output setup time, RGMII[x]_TD[3:0] valid to RGMII[x]_TXC high/low | 10Mbps | 1.2 | | ns |
| | | | 100Mbps | 1.2 | | ns |
| | | | 1000Mbps | 1.2 | | ns |
| | $t_{\text{osu}}(\text{TX_CTL-TXC})$ | Output setup time, RGMII[x]_TX_CTL valid to RGMII[x]_TXC high/low | 10Mbps | 1.2 | | ns |
| | | | 100Mbps | 1.2 | | ns |
| | | | 1000Mbps | 1.2 | | ns |
| RGMII10 | $t_{\text{oh}}(\text{TXC-TD})$ | Output hold time, RGMII[x]_TD[3:0] valid after RGMII[x]_TXC high/low | 10Mbps | 1.2 | | ns |
| | | | 100Mbps | 1.2 | | ns |
| | | | 1000Mbps | 1.2 | | ns |
| | $t_{\text{oh}}(\text{TXC-TX_CTL})$ | Output hold time, RGMII[x]_TX_CTL valid after RGMII[x]_TXC high/low | 10Mbps | 1.2 | | ns |
| | | | 100Mbps | 1.2 | | ns |
| | | | 1000Mbps | 1.2 | | ns |

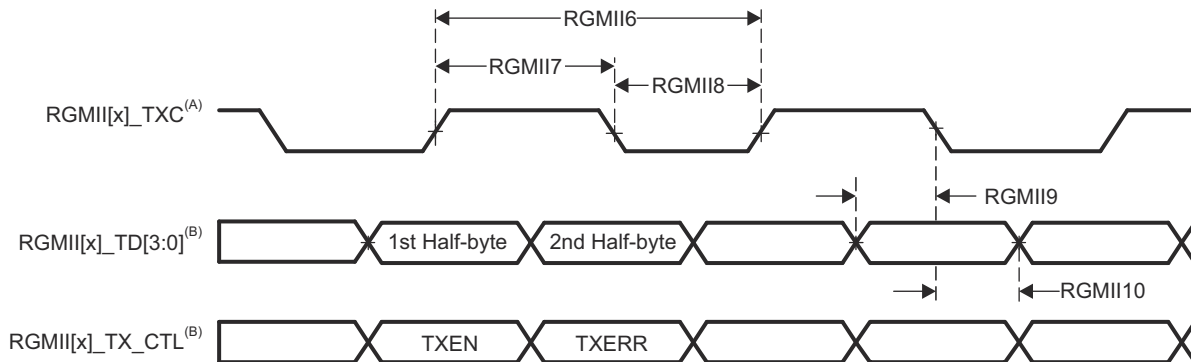

- A. TXC is delayed internally before being driven to the RGMII[x]_TXC pin. This internal delay is always enabled.
- B. Data and control information is received using both edges of the clocks. RGMII[x]_TD[3:0] carries data bits 3-0 on the rising edge of RGMII[x]_TXC and data bits 7-4 on the falling edge of RGMII[x]_TXC. Similarly, RGMII[x]_TX_CTL carries TXEN on rising edge of RGMII[x]_TXC and TXERR on falling edge of RGMII[x]_TXC.

Figure 6-27. CPSW3G RGMII[x]_TXC, RGMII[x]_TD[3:0], and RGMII[x]_TX_CTL Switching Characteristics - RGMII Mode

6.11.5.1.4 CPSW3G IOSETs

Table 6-37 defines valid pin combinations of each CPSW3G MDIO0 IOSET.

Table 6-37. CPSW3G MDIO0 IOSETs

| SIGNALS | IOSET1 | | IOSET2 | |
|------------|-----------------|---------|-----------------|---------|
| | BALL NAME | MUXMODE | BALL NAME | MUXMODE |
| MDIO0_MDIO | PRG0_PRU1_GPO18 | 4 | PRG1_MDIO0_MDIO | 4 |
| MDIO0_MDC | PRG0_PRU1_GPO19 | 4 | PRG1_MDIO0_MDC | 4 |

Table 6-38 defines valid pin combinations of each CPSW3G RMII1 and RMII2 IOSET.

Table 6-38. CPSW3G RMII1 and RMII2 IOSETs

| SIGNALS | IOSET1 | | IOSET2 | |
|-----------------------------|-----------------|---------|-----------------|---------|
| | BALL NAME | MUXMODE | BALL NAME | MUXMODE |
| RMII_REF_CLK ⁽¹⁾ | PRG1_PRU0_GPO10 | 5 | PRG0_PRU0_GPO10 | 5 |
| RMII1_CRS_DV | PRG1_PRU1_GPO19 | 5 | PRG0_PRU1_GPO19 | 5 |
| RMII1_RX_ER | PRG1_PRU0_GPO9 | 5 | PRG0_PRU0_GPO9 | 5 |
| RMII1_RXD0 | PRG1_PRU1_GPO7 | 5 | PRG0_PRU1_GPO7 | 5 |
| RMII1_RXD1 | PRG1_PRU1_GPO9 | 5 | PRG0_PRU1_GPO9 | 5 |
| RMII1_TXD0 | PRG1_PRU1_GPO10 | 5 | PRG0_PRU1_GPO10 | 5 |
| RMII1_TXD1 | PRG1_PRU1_GPO17 | 5 | PRG0_PRU1_GPO17 | 5 |
| RMII1_TX_EN | PRG1_PRU1_GPO18 | 5 | PRG0_PRU1_GPO18 | 5 |
| RMII2_CRS_DV | PRG1_PRU1_GPO13 | 5 | PRG1_PRU1_GPO13 | 5 |
| RMII2_RX_ER | PRG1_PRU1_GPO4 | 5 | PRG1_PRU1_GPO4 | 5 |
| RMII2_RXD0 | PRG1_PRU1_GPO0 | 5 | PRG1_PRU1_GPO0 | 5 |
| RMII2_RXD1 | PRG1_PRU1_GPO1 | 5 | PRG1_PRU1_GPO1 | 5 |
| RMII2_TXD0 | PRG1_PRU1_GPO11 | 5 | PRG1_PRU1_GPO11 | 5 |
| RMII2_TXD1 | PRG1_PRU1_GPO12 | 5 | PRG1_PRU1_GPO12 | 5 |
| RMII2_TX_EN | PRG1_PRU1_GPO15 | 5 | PRG1_PRU1_GPO15 | 5 |

(1) RMII_REF_CLK is common to both RMII1 and RMII2. For proper operation, all pin multiplexed signal assignments must use the same IOSET.

Table 6-39 defines valid pin combinations of each CPSW3G RGMII1 IOSET.

Table 6-39. CPSW3G RGMII1 IOSETs

| SIGNALS | IOSET1 | | IOSET2 | |
|---------------|-----------------|---------|-----------------|---------|
| | BALL NAME | MUXMODE | BALL NAME | MUXMODE |
| RGMII1_TX_CTL | PRG1_PRU0_GPO9 | 4 | PRG1_PRU0_GPO9 | 4 |
| RGMII1_TXC | PRG1_PRU0_GPO10 | 4 | PRG1_PRU0_GPO10 | 4 |
| RGMII1_TD0 | PRG1_PRU1_GPO7 | 4 | PRG1_PRU1_GPO7 | 4 |
| RGMII1_TD1 | PRG1_PRU1_GPO9 | 4 | PRG1_PRU1_GPO9 | 4 |
| RGMII1_TD2 | PRG1_PRU1_GPO10 | 4 | PRG1_PRU1_GPO10 | 4 |
| RGMII1_TD3 | PRG1_PRU1_GPO17 | 4 | PRG1_PRU1_GPO17 | 4 |
| RGMII1_RX_CTL | PRG0_PRU0_GPO9 | 4 | PRG1_PRU0_GPO5 | 4 |
| RGMII1_RXC | PRG0_PRU0_GPO10 | 4 | PRG1_PRU0_GPO8 | 4 |
| RGMII1_RD0 | PRG0_PRU1_GPO7 | 4 | PRG1_PRU1_GPO5 | 4 |
| RGMII1_RD1 | PRG0_PRU1_GPO9 | 4 | PRG1_PRU1_GPO8 | 4 |
| RGMII1_RD2 | PRG0_PRU1_GPO10 | 4 | PRG1_PRU1_GPO18 | 4 |
| RGMII1_RD3 | PRG0_PRU1_GPO17 | 4 | PRG1_PRU1_GPO19 | 4 |

6.11.5.2 DDRSS

For more details about features and additional description information on the device (LP)DDR4 Memory Interface, see the corresponding subsections within *Signal Descriptions* and *Detailed Description* sections.

Table 6-40 and Figure 6-28 present switching characteristics for DDRSS.

Table 6-40. DDRSS Switching Characteristics

see Figure 6-28

| NO. | PARAMETER | DDR TYPE | MIN | MAX | UNIT |
|-----|---|----------|---------------------|-----|------|
| 1 | $t_{c(DDR_CKP/DDR_CKN)}$ Cycle time, DDR_CKP and DDR_CKN | LPDDR4 | 1.25 ⁽¹⁾ | 20 | ns |
| | | DDR4 | 1.25 ⁽¹⁾ | 1.6 | ns |

- (1) Minimum DDR clock Cycle time will be limited based on the specific memory type (vendor) used in a system and by PCB implementation. Refer to [AM64x\AM243x DDR Board Design and Layout Guidelines](#) for the proper PCB implementation to achieve maximum DDR frequency.

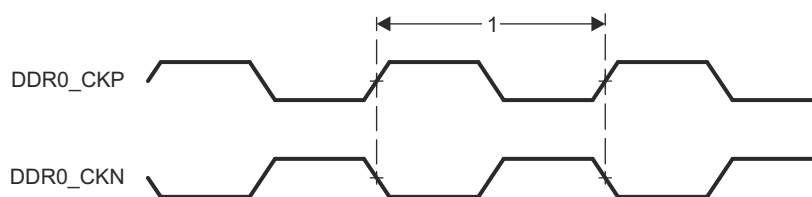

Figure 6-28. DDRSS Switching Characteristics

For more information, see *DDR Subsystem (DDRSS)* section in *Memory Controllers* chapter in the device TRM.

6.11.5.3 ECAP

Table 6-41, Table 6-42, Figure 6-29, Table 6-43, and Figure 6-30 present timing conditions, timing requirements, and switching characteristics for ECAP.

Table 6-41. ECAP Timing Conditions

| PARAMETER | | MIN | MAX | UNIT |
|--------------------------|-------------------------|-----|-----|------|
| INPUT CONDITIONS | | | | |
| SR _I | Input slew rate | 1 | 4 | V/ns |
| OUTPUT CONDITIONS | | | | |
| C _L | Output load capacitance | 2 | 7 | pF |

Table 6-42. ECAP Timing Requirements

see Figure 6-29

| NO. | PARAMETER | DESCRIPTION | MIN | MAX | UNIT |
|------|----------------------|------------------------------------|-----------------------|-----|------|
| CAP1 | t _w (CAP) | Pulse duration, CAP (asynchronous) | 2 + 2P ⁽¹⁾ | | ns |

(1) P = MAIN_SYSCCLK0/4 period in ns.

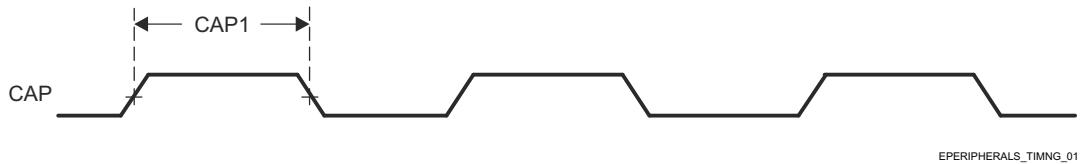

Figure 6-29. ECAP Timings Requirements

Table 6-43. ECAP Switching Characteristics

see Figure 6-30

| NO. | PARAMETER | DESCRIPTION | MIN | MAX | UNIT |
|------|-----------------------|--------------------------------|------------------------|-----|------|
| CAP2 | t _w (APWM) | Pulse duration, APWMx high/low | -2 + 2P ⁽¹⁾ | | ns |

(1) P = MAIN_SYSCCLK0/4 period in ns.

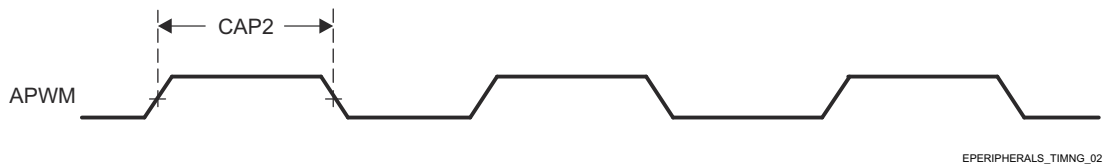

Figure 6-30. ECAP Switching Characteristics

For more information, see *Enhanced Capture (ECAP) Module* section in *Peripherals* chapter in the device TRM.

6.11.5.4 EPWM

Table 6-44, Table 6-45, Figure 6-31, Table 6-46, Figure 6-32, Figure 6-33, and Figure 6-34 present timing conditions, timing requirements, and switching characteristics for EPWM.

Table 6-44. EPWM Timing Conditions

| PARAMETER | | MIN | MAX | UNIT |
|--------------------------|-------------------------|-----|-----|------|
| INPUT CONDITIONS | | | | |
| SR _I | Input slew rate | 1 | 4 | V/ns |
| OUTPUT CONDITIONS | | | | |
| C _L | Output load capacitance | 2 | 7 | pF |

Table 6-45. EPWM Timing Requirements

see Figure 6-31

| NO. | PARAMETER | DESCRIPTION | MIN | MAX | UNIT |
|------|------------------------|-----------------------------------|-----------------------|-----|------|
| PWM6 | t _{w(SYNClN)} | Pulse duration, EHRPWM_SYNCI | 2 + 2P ⁽¹⁾ | | ns |
| PWM7 | t _{w(TZ)} | Pulse duration, EHRPWM_TZn_IN low | 2 + 3P ⁽¹⁾ | | ns |

(1) P = MAIN_SYSClk/2 period in ns.

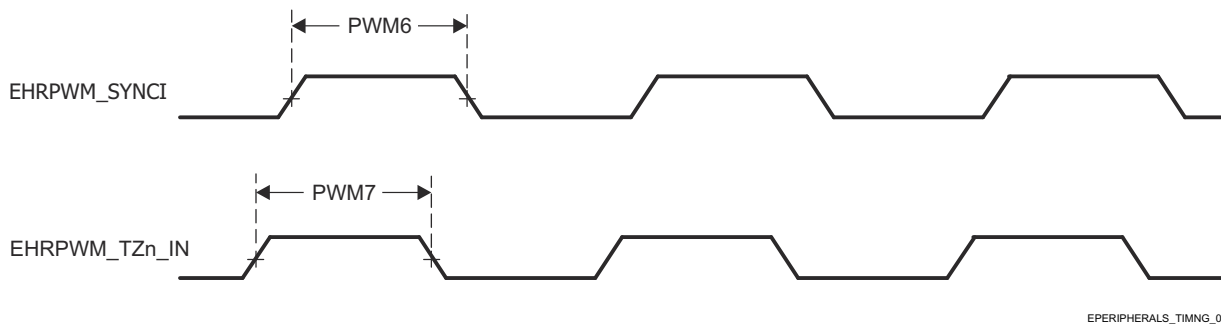

Figure 6-31. EPWM Timing Requirements

Table 6-46. EPWM Switching Characteristics

see [Figure 6-32](#), [Figure 6-33](#), and [Figure 6-34](#)

| NO. | PARAMETER | DESCRIPTION | MIN | MAX | UNIT |
|------|-----------------------|--|----------------------|-----|------|
| PWM1 | $t_w(\text{PWM})$ | Pulse duration, EHRPWM_A/B high/low | P - 3 ⁽¹⁾ | | ns |
| PWM2 | $t_w(\text{SYNCO})$ | Pulse duration, EHRPWM_SYNCO | P - 3 ⁽¹⁾ | | ns |
| PWM3 | $t_d(\text{TZ-PWM})$ | Delay time, EHRPWM_TZn_IN active to EHRPWM_A/B forced high/low | | 11 | ns |
| PWM4 | $t_d(\text{TZ-PWMZ})$ | Delay time, EHRPWM_TZn_IN active to EHRPWM_A/B Hi-Z | | 11 | ns |
| PWM5 | $t_w(\text{SOC})$ | Pulse duration, EHRPWM_SOC A/B output | P - 3 ⁽¹⁾ | | ns |

(1) P = MAIN_SYSCCLK0/2 period in ns.

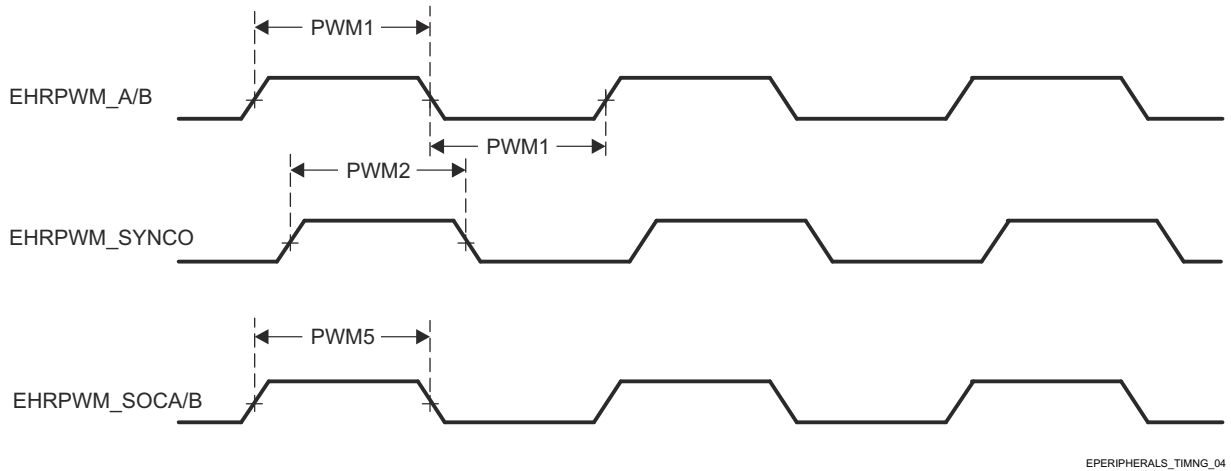

EPERIPHERALS_TIMNG_04

Figure 6-32. EHRPWM Switching Characteristics

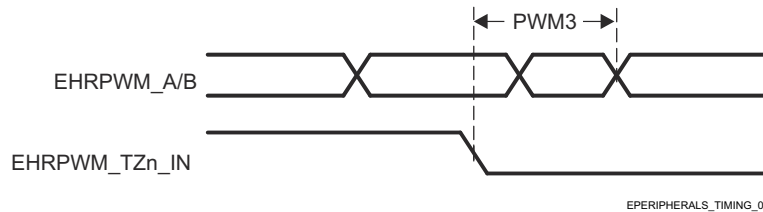

EPERIPHERALS_TIMNG_05

Figure 6-33. EHRPWM_TZn_IN to EHRPWM_A/B Forced Switching Characteristics

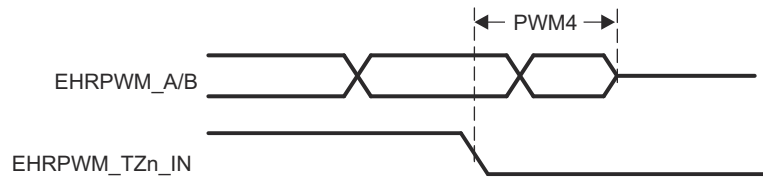

Figure 6-34. EHRPWM_TZn_IN to EHRPWM_A/B Hi-Z Switching Characteristics

For more information, see *Enhanced Pulse Width Modulation (EPWM) Module* section in *Peripherals* chapter in the device TRM.

6.11.5.5 EQEP

Table 6-47, Table 6-48, Figure 6-35, and Table 6-49 present timing conditions, timing requirements, and switching characteristics for EQEP.

Table 6-47. EQEP Timing Conditions

| PARAMETER | | MIN | MAX | UNIT |
|--------------------------|-------------------------|-----|-----|------|
| INPUT CONDITIONS | | | | |
| SR _I | Input slew rate | 1 | 4 | V/ns |
| OUTPUT CONDITIONS | | | | |
| C _L | Output load capacitance | 2 | 7 | pF |

Table 6-48. EQEP Timing Requirements

see Figure 6-35

| NO. | PARAMETER | DESCRIPTION | MIN | MAX | UNIT |
|------|------------------------|----------------------------|-----------------------|-----|------|
| QEP1 | t _{w(QEP)} | Pulse duration, QEP_A/B | 2 + 2P ⁽¹⁾ | | ns |
| QEP2 | t _{w(QEPIH)} | Pulse duration, QEP_I high | 2 + 2P ⁽¹⁾ | | ns |
| QEP3 | t _{w(QEPIL)} | Pulse duration, QEP_I low | 2 + 2P ⁽¹⁾ | | ns |
| QEP4 | t _{w(QEP SH)} | Pulse duration, QEP_S high | 2 + 2P ⁽¹⁾ | | ns |
| QEP5 | t _{w(QEP SL)} | Pulse duration, QEP_S low | 2 + 2P ⁽¹⁾ | | ns |

(1) P = MAIN_SYCLK0/4 period in ns

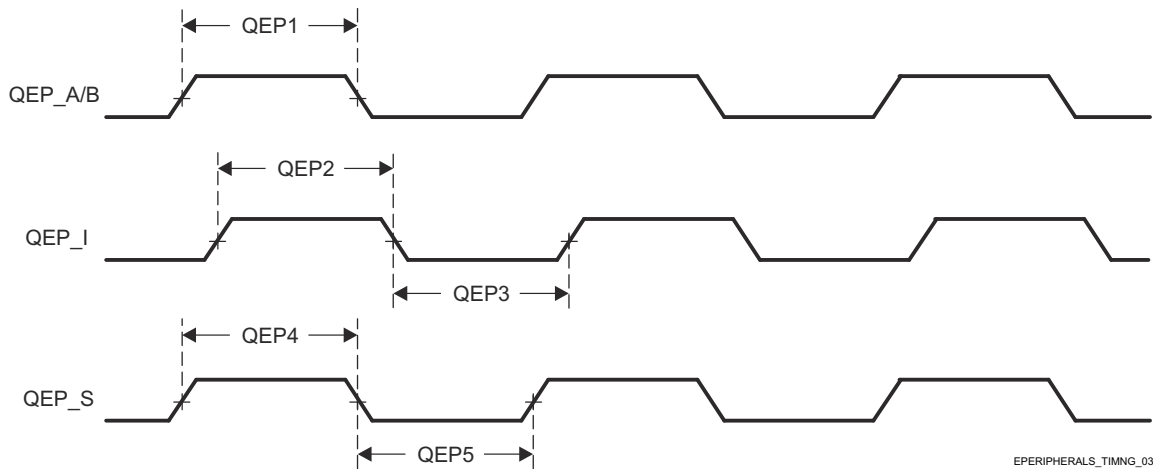

Figure 6-35. EQEP Timing Requirements

Table 6-49. EQEP Switching Characteristics

| NO. | PARAMETER | DESCRIPTION | MIN | MAX | UNIT |
|------|--------------------------|---|-----|-----|------|
| QEP6 | t _{d(QEP-CNTR)} | Delay time, external clock to counter increment | | 24 | ns |

For more information, see *Enhanced Quadrature Encoder Pulse (EQEP) Module* section in *Peripherals* chapter in the device TRM.

6.11.5.6 FSI

Table 6-50, Table 6-51, Figure 6-36, Table 6-52, Figure 6-37, Table 6-53, and Figure 6-38 present timing conditions, timing requirements, and switching characteristics for FSI.

Table 6-50. FSI Timing Conditions

| PARAMETER | | MIN | MAX | UNIT |
|--------------------------|-------------------------|-----|-----|------|
| INPUT CONDITIONS | | | | |
| SR _I | Input slew rate | 0.8 | 4 | V/ns |
| OUTPUT CONDITIONS | | | | |
| C _L | Output load capacitance | 1 | 7 | pF |

Table 6-51. FSI Timing Requirements

see Figure 6-36

| NO. | | | MIN | MAX | UNIT |
|-------|-------------------------------|---|-------------------------|-------------------------|------|
| FSIR1 | t _c (RX_CLK) | Cycle time, FSI_RXn_CLK | 20 | | ns |
| FSIR2 | t _w (RX_CLK) | Pulse width, FSI_RXn_CLK low or FSI_RXn_CLK high | 0.5P - 1 ⁽¹⁾ | 0.5P + 1 ⁽¹⁾ | ns |
| FSIR3 | t _{su} (RX_D-RX_CLK) | Setup time, FSI_RXn_D[1:0] valid before FSI_RXn_CLK | 3 | | ns |
| FSIR4 | t _h (RX_CLK-RX_D) | Hold time, FSI_RXn_D[1:0] valid after FSI_RXn_CLK | 2.5 | | ns |

(1) P = FSI_RXn_CLK period in ns.

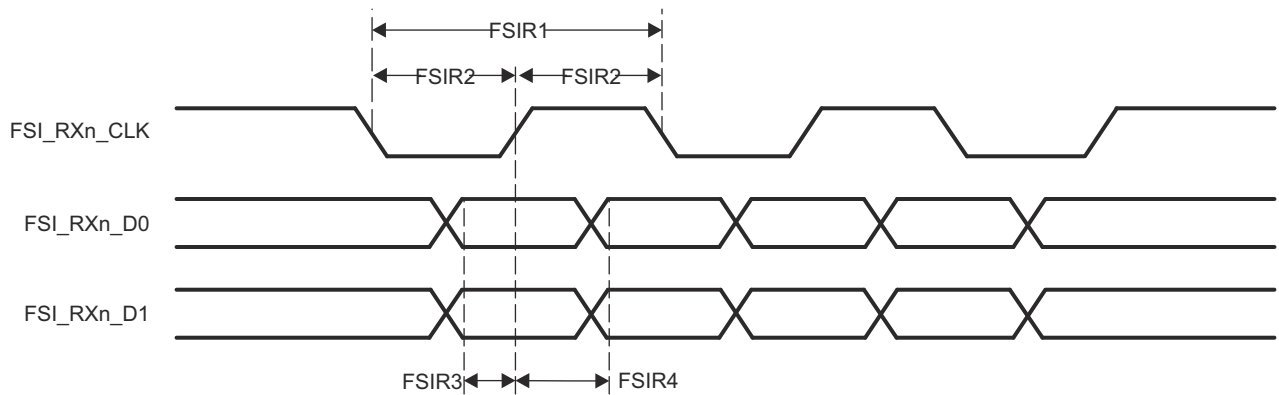

Figure 6-36. FSI Timing Requirements

Table 6-52. FSI Switching Characteristics - FSI Mode

see [Figure 6-37](#)

| NO. | PARAMETER | | MODE | MIN | MAX | UNIT |
|-------|------------------------|--|----------|-------------------|---------------------|------|
| FSIT1 | $t_{c(TX_CLK)}$ | Cycle time, FSI_TXn_CLK | FSI Mode | 20 | | ns |
| FSIT2 | $t_{w(TX_CLK)}$ | Pulse width, FSI_TXn_CLK low or FSI_TXn_CLK high | FSI Mode | $0.5P + 1^{(1)}$ | $0.5P - 1^{(1)}$ | ns |
| FSIT3 | $t_{d(TX_CLK-TX_D)}$ | Delay time, FSI_TXn_D[1:0] valid after FSI_TXn_CLK high or FSI_TXn_CLK low | FSI Mode | $0.25P - 2^{(1)}$ | $0.25P + 2.5^{(1)}$ | ns |

(1) P = FSI_TXn_CLK period in ns.

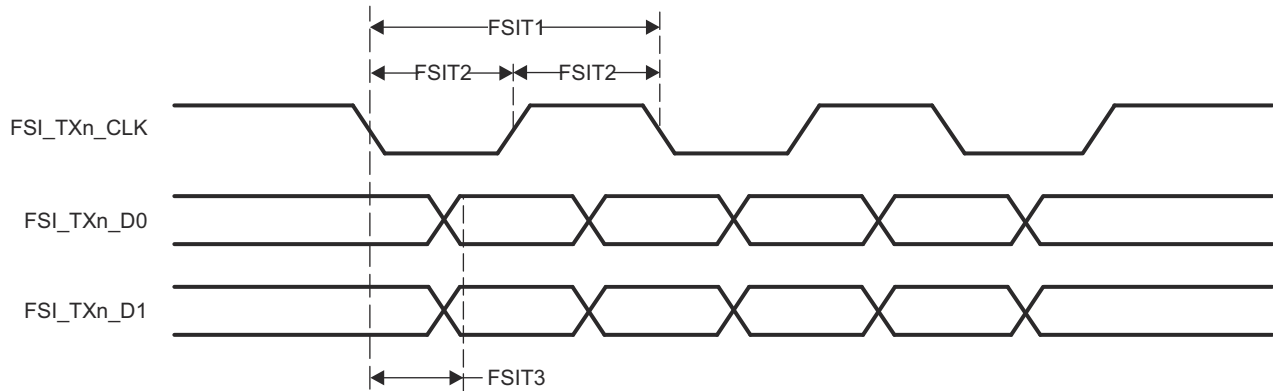

Figure 6-37. FSI Switching Characteristics - FSI Mode

Table 6-53. FSI Switching Characteristics - SPI Mode

see [Figure 6-38](#)

| NO. | PARAMETER | | MODE | MIN | MAX | UNIT |
|-------|--------------------------|--|----------|------------------|------------------|------|
| FSIT4 | $t_{c(TX_CLK)}$ | Cycle time, FSI_TXn_CLK | SPI Mode | 20 | | ns |
| FSIT5 | $t_{w(TX_CLK)}$ | Pulse width, FSI_TXn_CLK low or FSI_TXn_CLK high | SPI Mode | $0.5P + 1^{(1)}$ | $0.5P - 1^{(1)}$ | ns |
| FSIT6 | $t_{d(TX_CLKH-TX_D0)}$ | Delay time, FSI_TXn_CLK high to FSI_TXn_D0 valid | SPI Mode | | 3 | ns |
| FSIT7 | $t_{d(TX_D1-TX_CLK)}$ | Delay time, FSI_TXn_D1 low to FSI_TXn_CLK high | SPI Mode | $P - 3^{(1)}$ | | ns |
| FSIT8 | $t_{d(TX_CLK-TX_D1)}$ | Delay time, FSI_TXn_CLK low to FSI_TXn_D1 high | SPI Mode | $P - 2^{(1)}$ | | ns |

(1) P = FSI_TXn_CLK period in ns.

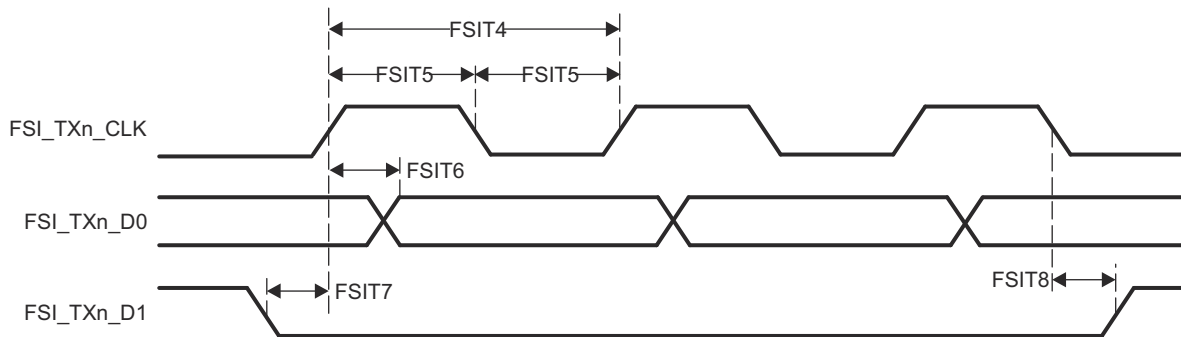

Figure 6-38. FSI Switching Characteristics - SPI Mode

For more information, see *Fast Serial Interface* section in *Peripherals* chapter in the device TRM.

6.11.5.7 GPIO

Table 6-54, Table 6-55, and Table 6-56 present timing conditions, timing requirements, and switching characteristics for GPIO.

The device has three instances of the GPIO module.

- MCU_GPIO0
- GPIO0
- GPIO1

Note

GPIO_{n_x} is generic name used to describe a GPIO signal, where n represents the specific GPIO module and x represents one of the input/output signals associated with the module.

For additional description information on the device GPIO, see the corresponding subsections within *Signal Descriptions* and *Detailed Description* sections.

Table 6-54. GPIO Timing Conditions

| PARAMETER | | BUFFER TYPE | MIN | MAX | UNIT |
|--------------------------|-------------------------|---------------------------------------|--------|------|------|
| INPUT CONDITIONS | | | | | |
| SR _i | Input slew rate | LVC MOS (VDD ⁽¹⁾ = 1.8V) | 0.0018 | 6.6 | V/ns |
| | | LVC MOS (VDD ⁽¹⁾ = 3.3V) | 0.0033 | 6.6 | |
| | | I2C OD FS (VDD ⁽¹⁾ = 1.8V) | 0.0018 | 6.6 | |
| | | I2C OD FS (VDD ⁽¹⁾ = 3.3V) | 0.0033 | 0.08 | |
| OUTPUT CONDITIONS | | | | | |
| C _L | Output load capacitance | LVC MOS | 3 | 10 | pF |
| | | I2C OD FS | 3 | 100 | pF |

(1) VDD stands for corresponding power supply. For more information on the power supply name and the corresponding ball(s), see POWER column of the *Pin Attributes* table.

Table 6-55. GPIO Timing Requirements

| NO. | PARAMETER | DESCRIPTION | MIN | MAX | UNIT |
|-------|-------------------------|----------------------------------|------------------------|-----|------|
| GPIO1 | t _{w(GPIO_IN)} | Pulse width, GPIO _{n_x} | 2P ⁽¹⁾ + 30 | | ns |

(1) P = functional clock period in ns.

Table 6-56. GPIO Switching Characteristics

| NO. | PARAMETER | DESCRIPTION | BUFFER TYPE | MIN | MAX | UNIT |
|-------|--------------------------|----------------------------------|-------------|-----------------------------|-----|------|
| GPIO2 | t _{w(GPIO_OUT)} | Pulse width, GPIO _{n_x} | LVC MOS | 0.975P ⁽¹⁾ - 3.6 | | ns |
| | | | I2C OD FS | 160 | | ns |

(1) P = functional clock period in ns.

For more information, see *General-Purpose Interface (GPIO)* section in *Peripherals* chapter in the device TRM.

6.11.5.8 GPMC

For more details about features and additional description information on the device General-Purpose Memory Controller, see the corresponding subsections within *Signal Descriptions* and *Detailed Description* sections.

Note

GPMC has one or more signals which can be multiplexed to more than one pin. Timing requirements and switching characteristics defined in this section are only valid for specific pin combinations known as IOSETs. Valid pin combinations or IOSETs for this interface is shown in [Section 5.3.12.1.1](#).

Table 6-57 presents timing conditions for GPMC.

Table 6-57. GPMC Timing Conditions

| PARAMETER | | MIN | MAX | UNIT | |
|---------------------------------------|--|-------------------------|-----|------|----|
| INPUT CONDITIONS | | | | | |
| SR _I | Input slew rate | 1.65 | 4 | V/ns | |
| OUTPUT CONDITIONS | | | | | |
| C _L | Output load capacitance | 133MHz Synchronous Mode | 3 | 20 | pF |
| | | All other modes | 3 | 30 | pF |
| PCB CONNECTIVITY REQUIREMENTS | | | | | |
| t _d (Trace Delay) | Propagation delay of each trace | 133MHz Synchronous Mode | 140 | 360 | ps |
| | | All other modes | 140 | 720 | ps |
| t _d (Trace Mismatch Delay) | Propagation delay mismatch across all traces | | 200 | ps | |

For more information, see *General-Purpose Memory Controller (GPMC)* section in *Peripherals* chapter in the device TRM.

6.11.5.8.1 GPMC and NOR Flash — Synchronous Mode

Table 6-58 and Table 6-59 present timing requirements and switching characteristics for GPMC and NOR Flash - Synchronous Mode.

Table 6-58. GPMC and NOR Flash Timing Requirements — Synchronous Mode

see [Figure 6-39](#), [Figure 6-40](#), and [Figure 6-43](#)

| NO. | PARAMETER | DESCRIPTION | MODE ⁽⁴⁾ | MIN | MAX | UNIT |
|-----|------------------------------|--|---------------------|--|--|------|
| | | | | 32-bit data bus (up to 100MHz) (1) | 16-bit data bus (up to 133MHz) (1) | |
| F12 | t _{su} (dV-clkH) | Setup time, GPMC0_AD[n:0] ⁽¹⁾ valid before GPMC0_CLK high | div_by_1_mode | 1.81 | 1.12 | ns |
| | | | not_div_by_1_mode | 1.06 | 3.5 | ns |
| F13 | t _h (clkH-dV) | Hold time, GPMC0_AD[n:0] ⁽¹⁾ valid after GPMC0_CLK high | div_by_1_mode | 2.29 | 2.29 | ns |
| | | | not_div_by_1_mode | 2.29 | 2.29 | ns |
| F21 | t _{su} (waitV-clkH) | Setup time, GPMC0_WAIT[j] ^{(2) (3)} valid before GPMC0_CLK high | div_by_1_mode | 1.81 | 1.12 | ns |
| | | | not_div_by_1_mode | 1.06 | 3.5 | ns |
| F22 | t _h (clkH-waitV) | Hold time, GPMC0_WAIT[j] ^{(2) (3)} valid after GPMC0_CLK high | div_by_1_mode | 2.29 | 2.29 | ns |
| | | | not_div_by_1_mode | 2.29 | 2.29 | ns |

(1) Synchronous Mode supports a 32-bit data bus (GPMC0_AD[31:0]) with GPMC0_CLK up to 100MHz and a 16-bit data bus (GPMC0_AD[15:0]) with GPMC0_CLK up to 133MHz. Select the clock source of GPMC0_FCLK which feeds GPMC0_CLK by writing to the CTRLMMR_GPMC0_CLKSEL register:

- 133MHz: CLK_SEL = 0h - MAIN_PLL0_HSDIV3_CLKOUT (default)
- 100MHz: CLK_SEL = 1h - MAIN_PLL2_HSDIV3_CLKOUT

(2) In GPMC_WAIT[j], j is equal to 0 or 1.

(3) Wait monitoring support is limited to a WaitMonitoringTime value > 0. For a full description of wait monitoring feature, see *General-Purpose Memory Controller (GPMC)* section in the device TRM.

- (4) For div_by_1_mode:
- GPMC_CONFIG1_i Register: GPMCFCLKDIVIDER = 0h:
 - GPMC0_CLK frequency = GPMC0_FCLK frequency
- For not_div_by_1_mode:
- GPMC_CONFIG1_i Register: GPMCFCLKDIVIDER = 1h to 3h:
 - GPMC0_CLK frequency = GPMC0_FCLK frequency / (2 to 4)

Table 6-59. GPMC and NOR Flash Switching Characteristics – Synchronous Mode

see [Figure 6-39](#), [Figure 6-40](#), [Figure 6-41](#), [Figure 6-42](#), and [Figure 6-43](#)

| NO. | PARAMETER | DESCRIPTION | MIN | MAX | UNIT |
|-----|-------------------------------|--|------------------------------|-------------------------|------|
| F0 | $t_{c(\text{clk})}$ | Cycle time, GPMC0_CLK ⁽¹⁶⁾ | 7.52 ⁽¹⁾ | | ns |
| F1 | $t_{w(\text{clkH})}$ | Typical pulse duration, GPMC0_CLK high | 0.475P ⁽¹⁴⁾ - 0.3 | | ns |
| F1 | $t_{w(\text{clkL})}$ | Typical pulse duration, GPMC0_CLK low | 0.475P ⁽¹⁴⁾ - 0.3 | | ns |
| F2 | $t_{d(\text{clkH-csn}[j]V)}$ | Delay time, GPMC0_CLK rising edge to GPMC0_CS _n [j] ⁽¹³⁾ transition | F ⁽⁶⁾ - 2.2 | F ⁽⁶⁾ + 1.31 | ns |
| F3 | $t_{d(\text{clkH-csn}[j]IV)}$ | Delay time, GPMC0_CLK rising edge to GPMC0_CS _n [j] ⁽¹³⁾ invalid | D ⁽⁵⁾ - 2.2 | D ⁽⁵⁾ + 1.31 | ns |
| F4 | $t_{d(\text{aV-clk})}$ | Delay time, GPMC0_A[27:1] valid to GPMC0_CLK first edge | B ⁽³⁾ - 2.3 | B ⁽³⁾ + 4.5 | ns |
| F5 | $t_{d(\text{clkH-aIV})}$ | Delay time, GPMC0_CLK rising edge to GPMC0_A[27:1] invalid | -2.3 | 4.5 | ns |
| F6 | $t_{d(\text{be}[x]nV-clk)}$ | Delay time, GPMC0_BE0 _n _CLE, GPMC0_BE1 _n , GPMC0_BE2 _n , GPMC0_BE3 _n valid to GPMC0_CLK first edge | B ⁽³⁾ - 2.3 | B ⁽³⁾ + 1.9 | ns |
| F7 | $t_{d(\text{clkH-be}[x]nIV)}$ | Delay time, GPMC0_CLK rising edge to GPMC0_BE0 _n _CLE, GPMC0_BE1 _n , GPMC0_BE2 _n , GPMC0_BE3 _n invalid | D ⁽⁵⁾ - 2.3 | D ⁽⁵⁾ + 1.9 | ns |
| F8 | $t_{d(\text{clkH-advn})}$ | Delay time, GPMC0_CLK rising edge to GPMC0_ADV _n _ALE transition | G ⁽⁷⁾ - 2.3 | G ⁽⁷⁾ + 4.5 | ns |
| F9 | $t_{d(\text{clkH-advnIV})}$ | Delay time, GPMC0_CLK rising edge to GPMC0_ADV _n _ALE invalid | D ⁽⁵⁾ - 2.3 | D ⁽⁵⁾ + 4.5 | ns |
| F10 | $t_{d(\text{clkH-oen})}$ | Delay time, GPMC0_CLK rising edge to GPMC0_OE _n _RE _n transition | H ⁽⁸⁾ - 2.3 | H ⁽⁸⁾ + 3.5 | ns |
| F11 | $t_{d(\text{clkH-oenIV})}$ | Delay time, GPMC0_CLK rising edge to GPMC0_OE _n _RE _n invalid | D ⁽⁵⁾ - 2.3 | D ⁽⁵⁾ + 3.5 | ns |
| F14 | $t_{d(\text{clkH-wen})}$ | Delay time, GPMC0_CLK rising edge to GPMC0_WE _n transition | I ⁽⁹⁾ - 2.3 | I ⁽⁹⁾ + 4.5 | ns |
| F15 | $t_{d(\text{clkH-do})}$ | Delay time, GPMC0_CLK rising edge to GPMC0_AD[n:0] ⁽¹⁾ transition ⁽¹⁰⁾ | -2.3 | 2.7 | ns |
| F15 | $t_{d(\text{clkL-do})}$ | Delay time, GPMC0_CLK falling edge to GPMC0_AD[n:0] ⁽¹⁾ transition ⁽¹¹⁾ | -2.3 | 2.7 | ns |
| F15 | $t_{d(\text{clkL-do})}$ | Delay time, GPMC0_CLK falling edge to GPMC0_AD[n:0] ⁽¹⁾ transition ⁽¹²⁾ | -2.3 | 2.7 | ns |
| F17 | $t_{d(\text{clkH-be}[x]n)}$ | Delay time, GPMC0_CLK rising edge to GPMC0_BE0 _n _CLE, GPMC0_BE1 _n , GPMC0_BE2 _n , GPMC0_BE3 _n transition ⁽¹⁰⁾ | -2.3 | 1.9 | ns |
| F17 | $t_{d(\text{clkL-be}[x]n)}$ | Delay time, GPMC0_CLK falling edge to GPMC0_BE0 _n _CLE, GPMC0_BE1 _n , GPMC0_BE2 _n , GPMC0_BE3 _n transition ⁽¹¹⁾ | -2.3 | 1.9 | ns |
| F17 | $t_{d(\text{clkL-be}[x]n)}$ | Delay time, GPMC0_CLK falling edge to GPMC0_BE0 _n _CLE, GPMC0_BE1 _n , GPMC0_BE2 _n , GPMC0_BE3 _n transition ⁽¹²⁾ | -2.3 | 1.9 | ns |
| F18 | $t_{w(\text{csnV})}$ | Pulse duration, GPMC0_CS _n [j] ⁽¹³⁾ low | A ⁽²⁾ | | ns |
| F19 | $t_{w(\text{be}[x]nV)}$ | Pulse duration, GPMC0_BE0 _n _CLE, GPMC0_BE1 _n , GPMC0_BE2 _n , GPMC0_BE3 _n low | C ⁽⁴⁾ | | ns |

Table 6-59. GPMC and NOR Flash Switching Characteristics – Synchronous Mode (continued)

see Figure 6-39, Figure 6-40, Figure 6-41, Figure 6-42, and Figure 6-43

| NO. | PARAMETER | DESCRIPTION | MIN | MAX | UNIT |
|-----|----------------|------------------------------------|-------------------|-----|------|
| F20 | $t_{w(advnV)}$ | Pulse duration, GPMC0_ADVn_ALE low | K ⁽¹⁵⁾ | | ns |

(1) Synchronous Mode supports a 32-bit data bus (GPMC0_AD[31:0]) with GPMC0_CLK up to 100MHz and a 16-bit data bus (GPMC0_AD[15:0]) with GPMC0_CLK up to 133MHz. Select the clock source of GPMC0_FCLK which feeds GPMC0_CLK by writing to the CTRLMMR_GPMC0_CLKSEL register:

- 133MHz: CLK_SEL = 0h - MAIN_PLL0_HSDIV3_CLKOUT (default)
- 100MHz: CLK_SEL = 1h - MAIN_PLL2_HSDIV3_CLKOUT

(2) For single read: $A = (CSRdOffTime - CSOnTime) \times (TimeParaGranularity + 1) \times GPMC0_FCLK^{(14)}$

For burst read: $A = (CSRdOffTime - CSOnTime + (n - 1) \times PageBurstAccessTime) \times (TimeParaGranularity + 1) \times GPMC0_FCLK^{(14)}$

For burst write: $A = (CSWrOffTime - CSOnTime + (n - 1) \times PageBurstAccessTime) \times (TimeParaGranularity + 1) \times GPMC0_FCLK^{(14)}$

With n being the page burst access number.

(3) Address bus / Byte Enables become valid at start of cycle, GPMC0_CLK activation time may be delayed after start of cycle $B = ClkActivationTime \times GPMC0_FCLK^{(14)}$

(4) For single read: $C = RdCycleTime \times (TimeParaGranularity + 1) \times GPMC0_FCLK^{(14)}$

For burst read: $C = (RdCycleTime + (n - 1) \times PageBurstAccessTime) \times (TimeParaGranularity + 1) \times GPMC0_FCLK^{(14)}$

For burst write: $C = (WrCycleTime + (n - 1) \times PageBurstAccessTime) \times (TimeParaGranularity + 1) \times GPMC0_FCLK^{(14)}$

With n being the page burst access number.

(5) For single read: $D = (RdCycleTime - RdAccessTime) \times (TimeParaGranularity + 1) \times GPMC0_FCLK^{(14)}$

For single write: $D = (WrCycleTime - WrAccessTime) \times (TimeParaGranularity + 1) \times GPMC0_FCLK^{(14)}$

For burst read: $D = (RdCycleTime - RdAccessTime + (n - 1) \times PageBurstAccessTime) \times (TimeParaGranularity + 1) \times GPMC0_FCLK^{(14)}$

For burst write: $D = (WrCycleTime - WrAccessTime + (n - 1) \times PageBurstAccessTime) \times (TimeParaGranularity + 1) \times GPMC0_FCLK^{(14)}$

With n being the page burst access number.

(6) For CSn falling edge (CS activated):

- Case GPMCFCLKDIVIDER = 0:
 - $F = 0.5 \times CSExtraDelay \times GPMC0_FCLK^{(14)}$
- Case GPMCFCLKDIVIDER = 1:
 - $F = 0.5 \times CSExtraDelay \times GPMC0_FCLK^{(14)}$ if (ClkActivationTime and CSOnTime are odd) or (ClkActivationTime and CSOnTime are even)
 - $F = (1 + 0.5 \times CSExtraDelay) \times GPMC0_FCLK^{(14)}$ otherwise
- Case GPMCFCLKDIVIDER = 2:
 - $F = 0.5 \times CSExtraDelay \times GPMC0_FCLK^{(14)}$ if ((CSOnTime - ClkActivationTime) is a multiple of 3)
 - $F = (1 + 0.5 \times CSExtraDelay) \times GPMC0_FCLK^{(14)}$ if ((CSOnTime - ClkActivationTime - 1) is a multiple of 3)
 - $F = (2 + 0.5 \times CSExtraDelay) \times GPMC0_FCLK^{(14)}$ if ((CSOnTime - ClkActivationTime - 2) is a multiple of 3)

For CSn rising edge (CS deactivated) in Reading mode:

- Case GPMCFCLKDIVIDER = 0:
 - $F = 0.5 \times CSExtraDelay \times GPMC0_FCLK^{(14)}$
- Case GPMCFCLKDIVIDER = 1:
 - $F = 0.5 \times CSExtraDelay \times GPMC0_FCLK^{(14)}$ if (ClkActivationTime and CSRdOffTime are odd) or (ClkActivationTime and CSRdOffTime are even)
 - $F = (1 + 0.5 \times CSExtraDelay) \times GPMC0_FCLK^{(14)}$ otherwise
- Case GPMCFCLKDIVIDER = 2:
 - $F = 0.5 \times CSExtraDelay \times GPMC0_FCLK^{(14)}$ if ((CSRdOffTime - ClkActivationTime) is a multiple of 3)
 - $F = (1 + 0.5 \times CSExtraDelay) \times GPMC0_FCLK^{(14)}$ if ((CSRdOffTime - ClkActivationTime - 1) is a multiple of 3)
 - $F = (2 + 0.5 \times CSExtraDelay) \times GPMC0_FCLK^{(14)}$ if ((CSRdOffTime - ClkActivationTime - 2) is a multiple of 3)

For CSn rising edge (CS deactivated) in Writing mode:

- Case GPMCFCLKDIVIDER = 0:
 - $F = 0.5 \times CSExtraDelay \times GPMC0_FCLK^{(14)}$
- Case GPMCFCLKDIVIDER = 1:
 - $F = 0.5 \times CSExtraDelay \times GPMC0_FCLK^{(14)}$ if (ClkActivationTime and CSWrOffTime are odd) or (ClkActivationTime and CSWrOffTime are even)
 - $F = (1 + 0.5 \times CSExtraDelay) \times GPMC0_FCLK^{(14)}$ otherwise
- Case GPMCFCLKDIVIDER = 2:

- $F = 0.5 \times \text{CSEExtraDelay} \times \text{GPMC0_FCLK}^{(14)}$ if $((\text{CSWrOffTime} - \text{ClkActivationTime})$ is a multiple of 3)
- $F = (1 + 0.5 \times \text{CSEExtraDelay}) \times \text{GPMC0_FCLK}^{(14)}$ if $((\text{CSWrOffTime} - \text{ClkActivationTime} - 1)$ is a multiple of 3)
- $F = (2 + 0.5 \times \text{CSEExtraDelay}) \times \text{GPMC0_FCLK}^{(14)}$ if $((\text{CSWrOffTime} - \text{ClkActivationTime} - 2)$ is a multiple of 3)

(7) For ADV falling edge (ADV activated):

- Case $\text{GPMCFCLKDIVIDER} = 0$:
 - $G = 0.5 \times \text{ADVExtraDelay} \times \text{GPMC0_FCLK}^{(14)}$
- Case $\text{GPMCFCLKDIVIDER} = 1$:
 - $G = 0.5 \times \text{ADVExtraDelay} \times \text{GPMC0_FCLK}^{(14)}$ if $(\text{ClkActivationTime}$ and ADVOnTime are odd) or $(\text{ClkActivationTime}$ and ADVOnTime are even)
 - $G = (1 + 0.5 \times \text{ADVExtraDelay}) \times \text{GPMC0_FCLK}^{(14)}$ otherwise
- Case $\text{GPMCFCLKDIVIDER} = 2$:
 - $G = 0.5 \times \text{ADVExtraDelay} \times \text{GPMC0_FCLK}^{(14)}$ if $((\text{ADVOnTime} - \text{ClkActivationTime})$ is a multiple of 3)
 - $G = (1 + 0.5 \times \text{ADVExtraDelay}) \times \text{GPMC0_FCLK}^{(14)}$ if $((\text{ADVOnTime} - \text{ClkActivationTime} - 1)$ is a multiple of 3)
 - $G = (2 + 0.5 \times \text{ADVExtraDelay}) \times \text{GPMC0_FCLK}^{(14)}$ if $((\text{ADVOnTime} - \text{ClkActivationTime} - 2)$ is a multiple of 3)

For ADV rising edge (ADV deactivated) in Reading mode:

- Case $\text{GPMCFCLKDIVIDER} = 0$:
 - $G = 0.5 \times \text{ADVExtraDelay} \times \text{GPMC0_FCLK}^{(14)}$
- Case $\text{GPMCFCLKDIVIDER} = 1$:
 - $G = 0.5 \times \text{ADVExtraDelay} \times \text{GPMC0_FCLK}^{(14)}$ if $(\text{ClkActivationTime}$ and ADVRdOffTime are odd) or $(\text{ClkActivationTime}$ and ADVRdOffTime are even)
 - $G = (1 + 0.5 \times \text{ADVExtraDelay}) \times \text{GPMC0_FCLK}^{(14)}$ otherwise
- Case $\text{GPMCFCLKDIVIDER} = 2$:
 - $G = 0.5 \times \text{ADVExtraDelay} \times \text{GPMC0_FCLK}^{(14)}$ if $((\text{ADVRdOffTime} - \text{ClkActivationTime})$ is a multiple of 3)
 - $G = (1 + 0.5 \times \text{ADVExtraDelay}) \times \text{GPMC0_FCLK}^{(14)}$ if $((\text{ADVRdOffTime} - \text{ClkActivationTime} - 1)$ is a multiple of 3)
 - $G = (2 + 0.5 \times \text{ADVExtraDelay}) \times \text{GPMC0_FCLK}^{(14)}$ if $((\text{ADVRdOffTime} - \text{ClkActivationTime} - 2)$ is a multiple of 3)

For ADV rising edge (ADV deactivated) in Writing mode:

- Case $\text{GPMCFCLKDIVIDER} = 0$:
 - $G = 0.5 \times \text{ADVExtraDelay} \times \text{GPMC0_FCLK}^{(14)}$
- Case $\text{GPMCFCLKDIVIDER} = 1$:
 - $G = 0.5 \times \text{ADVExtraDelay} \times \text{GPMC0_FCLK}^{(14)}$ if $(\text{ClkActivationTime}$ and ADVWrOffTime are odd) or $(\text{ClkActivationTime}$ and ADVWrOffTime are even)
 - $G = (1 + 0.5 \times \text{ADVExtraDelay}) \times \text{GPMC0_FCLK}^{(14)}$ otherwise
- Case $\text{GPMCFCLKDIVIDER} = 2$:
 - $G = 0.5 \times \text{ADVExtraDelay} \times \text{GPMC0_FCLK}^{(14)}$ if $((\text{ADVWrOffTime} - \text{ClkActivationTime})$ is a multiple of 3)
 - $G = (1 + 0.5 \times \text{ADVExtraDelay}) \times \text{GPMC0_FCLK}^{(14)}$ if $((\text{ADVWrOffTime} - \text{ClkActivationTime} - 1)$ is a multiple of 3)
 - $G = (2 + 0.5 \times \text{ADVExtraDelay}) \times \text{GPMC0_FCLK}^{(14)}$ if $((\text{ADVWrOffTime} - \text{ClkActivationTime} - 2)$ is a multiple of 3)

(8) For OE falling edge (OE activated) and IO DIR rising edge (Data Bus input direction):

- Case $\text{GPMCFCLKDIVIDER} = 0$:
 - $H = 0.5 \times \text{OEExtraDelay} \times \text{GPMC0_FCLK}^{(14)}$
- Case $\text{GPMCFCLKDIVIDER} = 1$:
 - $H = 0.5 \times \text{OEExtraDelay} \times \text{GPMC0_FCLK}^{(14)}$ if $(\text{ClkActivationTime}$ and OEOnTime are odd) or $(\text{ClkActivationTime}$ and OEOnTime are even)
 - $H = (1 + 0.5 \times \text{OEExtraDelay}) \times \text{GPMC0_FCLK}^{(14)}$ otherwise
- Case $\text{GPMCFCLKDIVIDER} = 2$:
 - $H = 0.5 \times \text{OEExtraDelay} \times \text{GPMC0_FCLK}^{(14)}$ if $((\text{OEOnTime} - \text{ClkActivationTime})$ is a multiple of 3)
 - $H = (1 + 0.5 \times \text{OEExtraDelay}) \times \text{GPMC0_FCLK}^{(14)}$ if $((\text{OEOnTime} - \text{ClkActivationTime} - 1)$ is a multiple of 3)
 - $H = (2 + 0.5 \times \text{OEExtraDelay}) \times \text{GPMC0_FCLK}^{(14)}$ if $((\text{OEOnTime} - \text{ClkActivationTime} - 2)$ is a multiple of 3)

For OE rising edge (OE deactivated):

- Case $\text{GPMCFCLKDIVIDER} = 0$:
 - $H = 0.5 \times \text{OEExtraDelay} \times \text{GPMC0_FCLK}^{(14)}$
- Case $\text{GPMCFCLKDIVIDER} = 1$:

- $H = 0.5 \times \text{OEEExtraDelay} \times \text{GPMC0_FCLK}^{(14)}$ if (ClkActivationTime and OEOffTime are odd) or (ClkActivationTime and OEOffTime are even)
 - $H = (1 + 0.5 \times \text{OEEExtraDelay}) \times \text{GPMC0_FCLK}^{(14)}$ otherwise
 - Case GPMCFCLKDIVIDER = 2:
 - $H = 0.5 \times \text{OEEExtraDelay} \times \text{GPMC0_FCLK}^{(14)}$ if ((OEOffTime - ClkActivationTime) is a multiple of 3)
 - $H = (1 + 0.5 \times \text{OEEExtraDelay}) \times \text{GPMC0_FCLK}^{(14)}$ if ((OEOffTime - ClkActivationTime - 1) is a multiple of 3)
 - $H = (2 + 0.5 \times \text{OEEExtraDelay}) \times \text{GPMC0_FCLK}^{(14)}$ if ((OEOffTime - ClkActivationTime - 2) is a multiple of 3)
- (9) For WE falling edge (WE activated):
- Case GPMCFCLKDIVIDER = 0:
 - $I = 0.5 \times \text{WEEExtraDelay} \times \text{GPMC0_FCLK}^{(14)}$
 - Case GPMCFCLKDIVIDER = 1:
 - $I = 0.5 \times \text{WEEExtraDelay} \times \text{GPMC0_FCLK}^{(14)}$ if (ClkActivationTime and WEOffTime are odd) or (ClkActivationTime and WEOffTime are even)
 - $I = (1 + 0.5 \times \text{WEEExtraDelay}) \times \text{GPMC0_FCLK}^{(14)}$ otherwise
 - Case GPMCFCLKDIVIDER = 2:
 - $I = 0.5 \times \text{WEEExtraDelay} \times \text{GPMC0_FCLK}^{(14)}$ if ((WEOffTime - ClkActivationTime) is a multiple of 3)
 - $I = (1 + 0.5 \times \text{WEEExtraDelay}) \times \text{GPMC0_FCLK}^{(14)}$ if ((WEOffTime - ClkActivationTime - 1) is a multiple of 3)
 - $I = (2 + 0.5 \times \text{WEEExtraDelay}) \times \text{GPMC0_FCLK}^{(14)}$ if ((WEOffTime - ClkActivationTime - 2) is a multiple of 3)
- For WE rising edge (WE deactivated):
- Case GPMCFCLKDIVIDER = 0:
 - $I = 0.5 \times \text{WEEExtraDelay} \times \text{GPMC0_FCLK}^{(14)}$
 - Case GPMCFCLKDIVIDER = 1:
 - $I = 0.5 \times \text{WEEExtraDelay} \times \text{GPMC0_FCLK}^{(14)}$ if (ClkActivationTime and WEOffTime are odd) or (ClkActivationTime and WEOffTime are even)
 - $I = (1 + 0.5 \times \text{WEEExtraDelay}) \times \text{GPMC0_FCLK}^{(14)}$ otherwise
 - Case GPMCFCLKDIVIDER = 2:
 - $I = 0.5 \times \text{WEEExtraDelay} \times \text{GPMC0_FCLK}^{(14)}$ if ((WEOffTime - ClkActivationTime) is a multiple of 3)
 - $I = (1 + 0.5 \times \text{WEEExtraDelay}) \times \text{GPMC0_FCLK}^{(14)}$ if ((WEOffTime - ClkActivationTime - 1) is a multiple of 3)
 - $I = (2 + 0.5 \times \text{WEEExtraDelay}) \times \text{GPMC0_FCLK}^{(14)}$ if ((WEOffTime - ClkActivationTime - 2) is a multiple of 3)
- (10) Case GPMC0_CLK in div_by_1_mode⁽¹⁷⁾, first transfer only: Data and byte enables transition on rise edge of GPMC0_CLK
- Non-multiplexed mode: data transition at start of cycle
 - Multiplexed mode: data transition at $\text{WRDATAONADMUXBUS} \times (\text{TimeParaGranularity} + 1) \times \text{GPMC0_FCLK}^{(14)}$
- (11) Case GPMC0_CLK in div_by_1_mode⁽¹⁷⁾, all data and byte enables after initial transfer: Data and byte enables transition on fall edge of GPMC0_CLK (Half cycle of GPMC0_CLK)
- (12) Case GPMC0_CLK in not_div_by_1_mode⁽¹⁷⁾ (GPMC0_CLK divided down from GPMC0_FCLK): All data and byte enables transition on fall edge of GPMC0_CLK (Half cycle of GPMC0_CLK). ClkActivationTime, GPMCFCLKDIVIDER, RDACCESSTIME/WRACCESSTIME, and PAGEBURSTACCESSTIME configuration must be configured to enforce data and byte enables transition on falling edge of GPMC0_CLK (to be latched on rise edge of GPMC0_CLK)
- (13) In GPMC0_CS*n*[*i*], *i* is equal to 0, 1, 2 or 3.
- (14) $P = \text{GPMC0_CLK}$ period in ns
- (15) For read: $K = (\text{ADVrdOffTime} - \text{ADVOnTime}) \times (\text{TimeParaGranularity} + 1) \times \text{GPMC0_FCLK}^{(14)}$
For write: $K = (\text{ADVWrOffTime} - \text{ADVOnTime}) \times (\text{TimeParaGranularity} + 1) \times \text{GPMC0_FCLK}^{(14)}$
- (16) Related to the GPMC0_CLK output clock maximum and minimum frequencies programmable in the GPMC module by setting the GPMC0_CONFIG1_*i* configuration register bit field GPMCFCLKDIVIDER.
- (17) For div_by_1_mode:
- GPMC_CONFIG1_*i* Register: GPMCFCLKDIVIDER = 0h:
 - GPMC0_CLK frequency = GPMC0_FCLK frequency
- For not_div_by_1_mode:
- GPMC_CONFIG1_*i* Register: GPMCFCLKDIVIDER = 1h to 3h:
 - GPMC0_CLK frequency = GPMC0_FCLK frequency / (2 to 4)

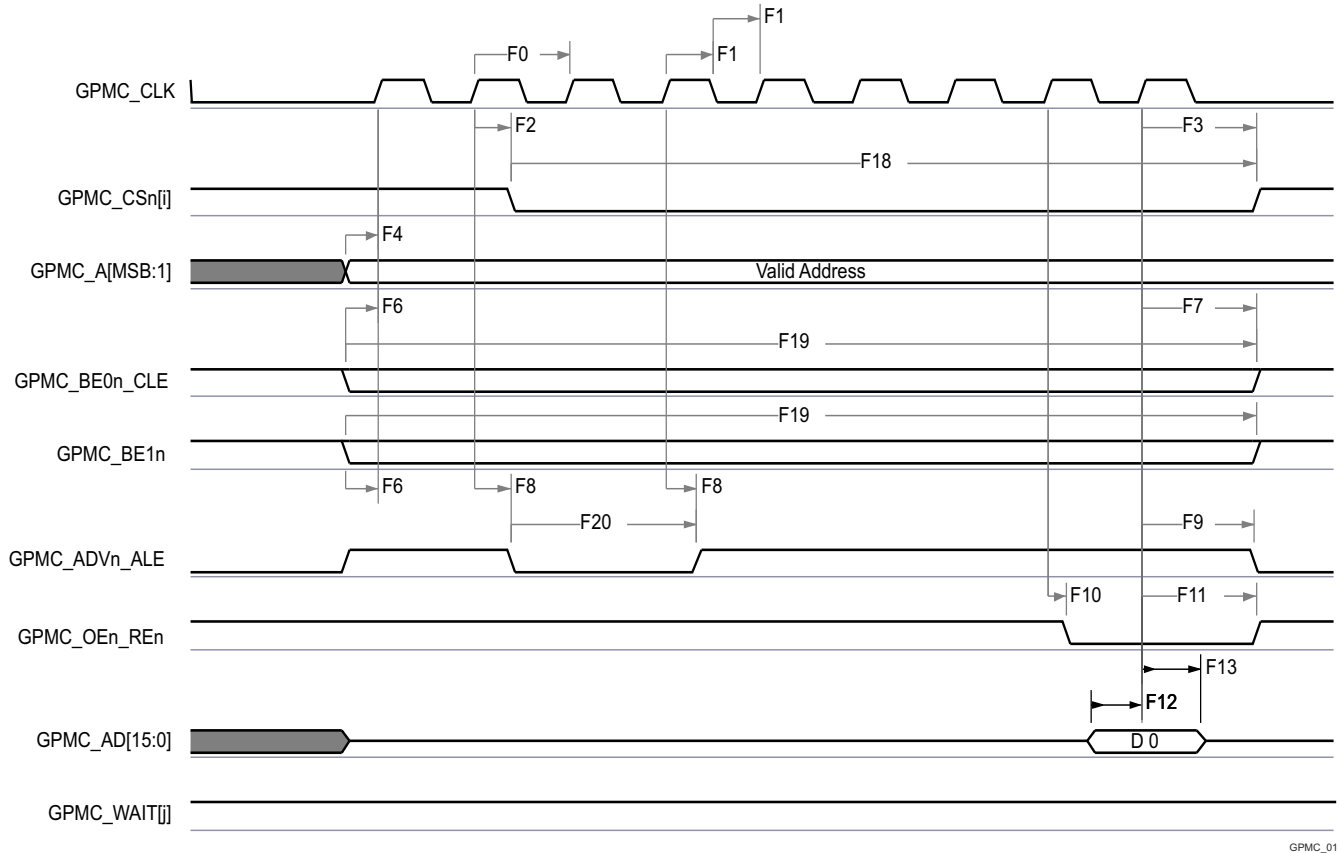

GPMC_01

- A. In GPMC0_CSn[i], i is equal to 0, 1, 2 or 3.
- B. In GPMC0_WAIT[j], j is equal to 0 or 1.

Figure 6-39. GPMC and NOR Flash — Synchronous Single Read (GPMCFCLKDIVIDER = 0)

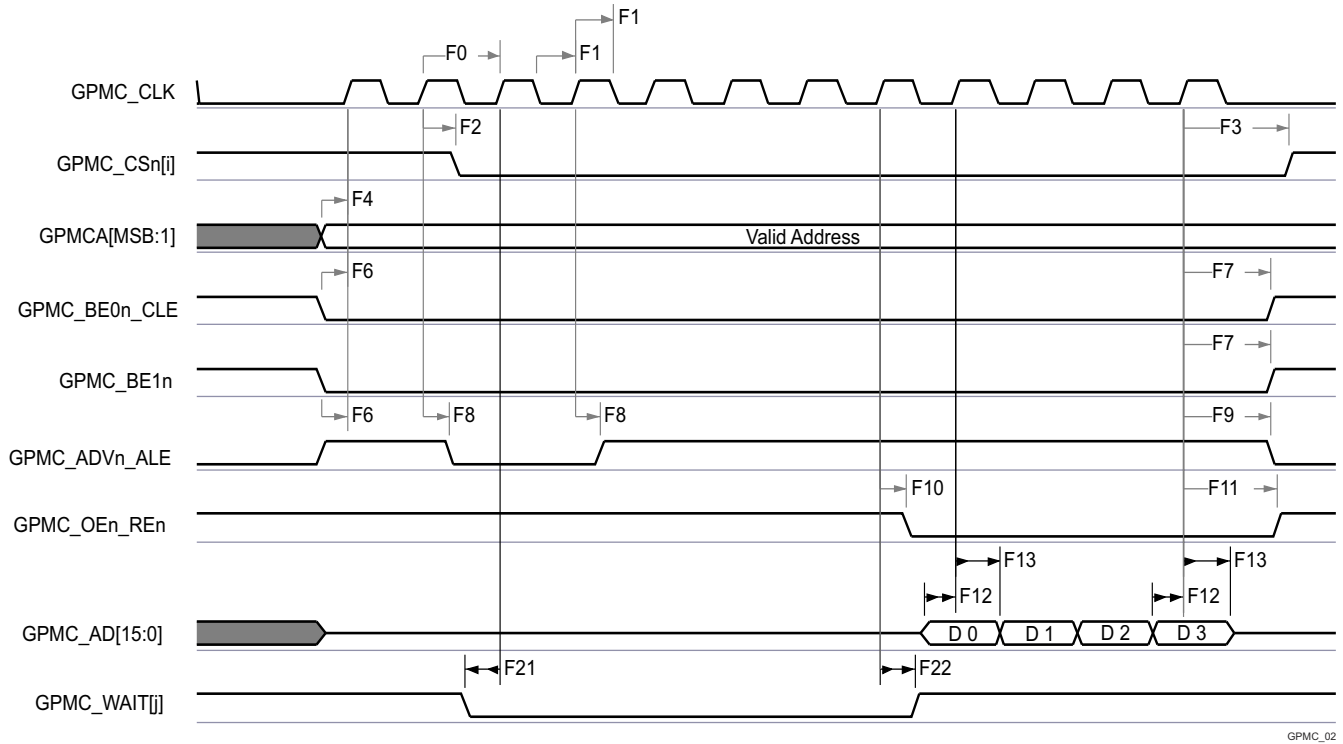

GPMC_02

- A. In GPMC0_CS[n][i], i is equal to 0, 1, 2 or 3.
- B. In GPMC0_WAIT[j], j is equal to 0 or 1.

Figure 6-40. GPMC and NOR Flash — Synchronous Burst Read — 4x16-bit (GPMCFCLKDIVIDER = 0)

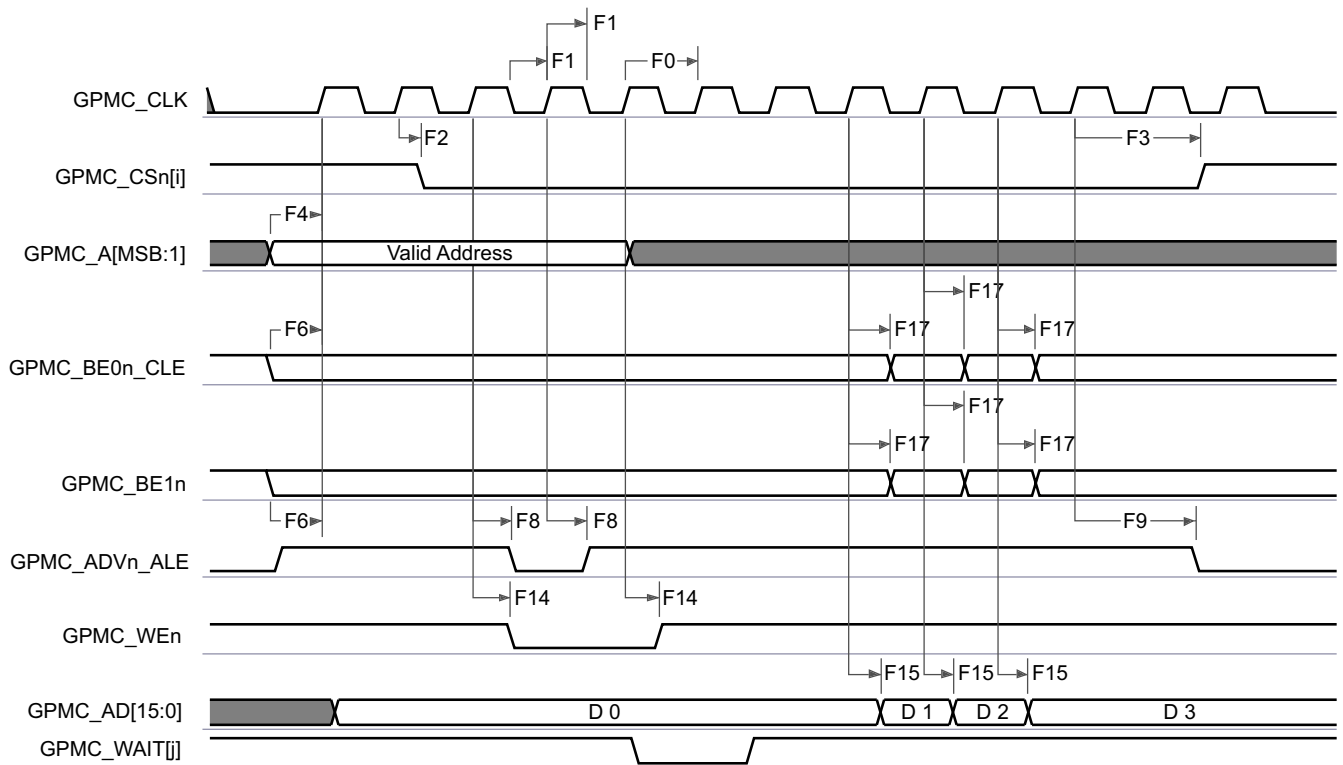

GPMC_03

- A. In GPMC0_CS[n][i], i is equal to 0, 1, 2 or 3.

B. In GPMC0_WAIT[j], j is equal to 0 or 1.

Figure 6-41. GPMC and NOR Flash—Synchronous Burst Write (GPMCFCLKDIVIDER = 0)

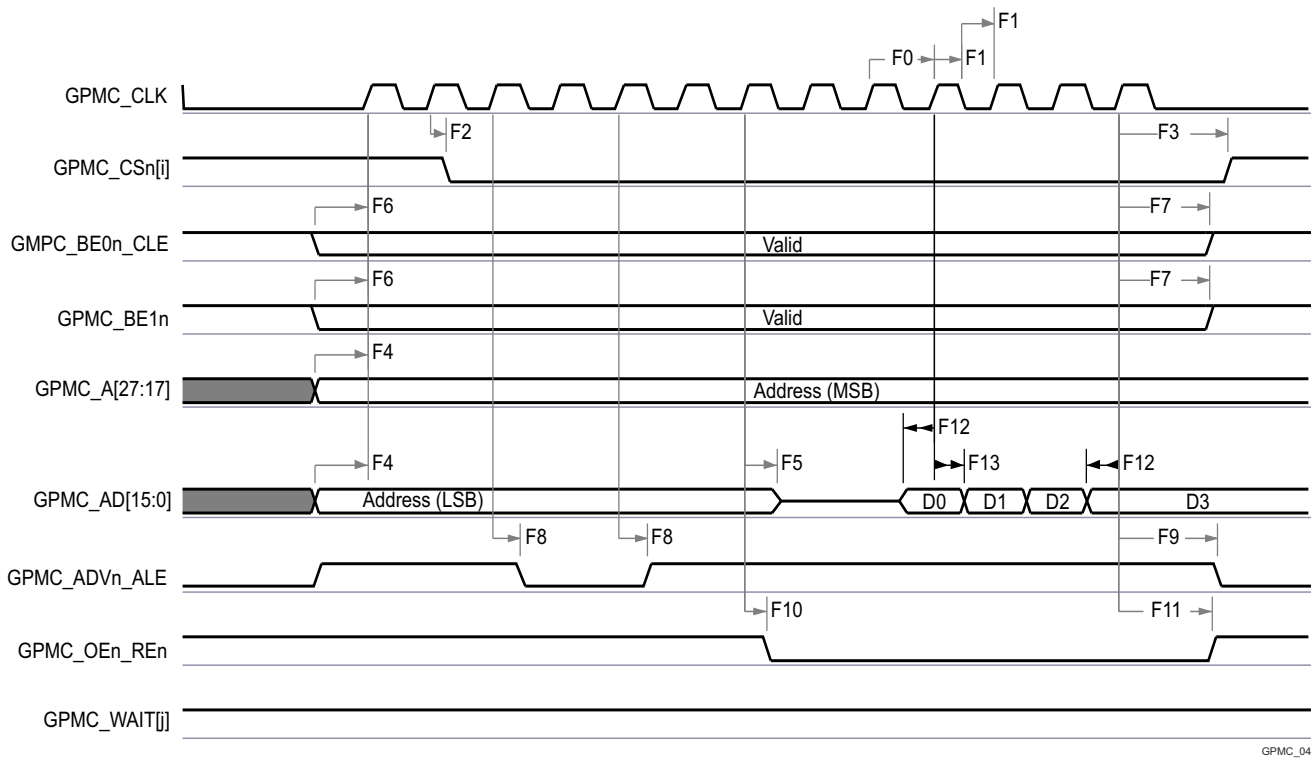

GPMC_04

- A. In GPMC0_CSn[i], i is equal to 0, 1, 2 or 3.
B. In GPMC0_WAIT[j], j is equal to 0 or 1.

Figure 6-42. GPMC and Multiplexed NOR Flash — Synchronous Burst Read

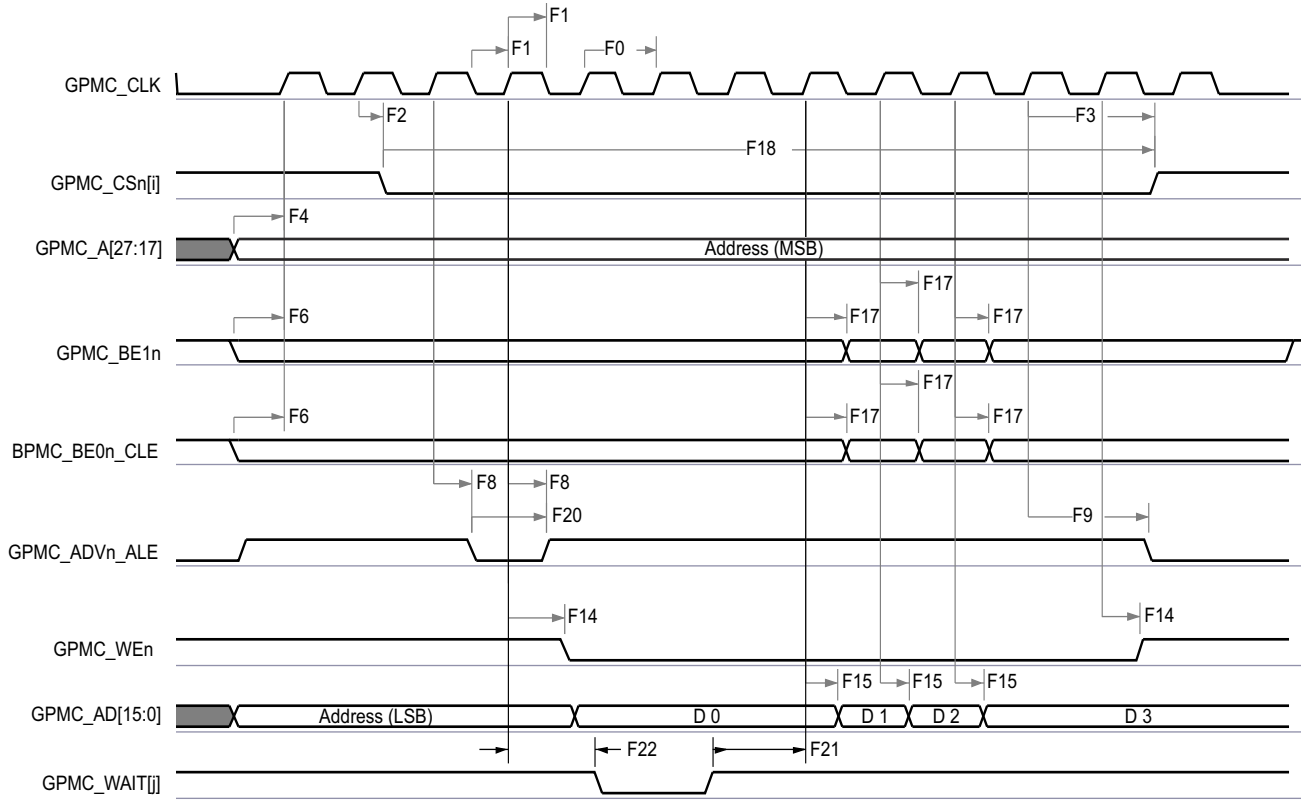

GPMC_05

- A. In GPMC0_CSn[i], i is equal to 0, 1, 2 or 3.
- B. In GPMC0_WAIT[j], j is equal to 0 or 1.

Figure 6-43. GPMC and Multiplexed NOR Flash — Synchronous Burst Write

6.11.5.8.2 GPMC and NOR Flash — Asynchronous Mode

Table 6-60 and Table 6-61 present timing requirements and switching characteristics for GPMC and NOR Flash — Asynchronous Mode.

Table 6-60. GPMC and NOR Flash Timing Requirements – Asynchronous Mode

see Figure 6-44, Figure 6-45, Figure 6-46, and Figure 6-48

| NO. | PARAMETER | DESCRIPTION | MIN | MAX | UNIT |
|---------------------|-----------------------------|---------------------------------------|-----|------------------|------|
| FA5 ⁽¹⁾ | t _{acc(d)} | Data access time | | H ⁽⁵⁾ | ns |
| FA20 ⁽²⁾ | t _{acc1-pgmode(d)} | Page mode successive data access time | | P ⁽⁴⁾ | ns |
| FA21 ⁽³⁾ | t _{acc2-pgmode(d)} | Page mode first data access time | | H ⁽⁵⁾ | ns |

- (1) The FA5 parameter illustrates the amount of time required to internally sample input data. It is expressed in number of GPMC functional clock cycles. From start of read cycle and after FA5 functional clock cycles, input data is internally sampled by active functional clock edge. FA5 value must be stored inside the AccessTime register bit field.
- (2) The FA20 parameter illustrates amount of time required to internally sample successive input page data. It is expressed in number of GPMC functional clock cycles. After each access to input page data, next input page data is internally sampled by active functional clock edge after FA20 functional clock cycles. The FA20 value must be stored in the PageBurstAccessTime register bit field.
- (3) The FA21 parameter illustrates amount of time required to internally sample first input page data. It is expressed in number of GPMC functional clock cycles. From start of read cycle and after FA21 functional clock cycles, first input page data is internally sampled by active functional clock edge. FA21 value must be stored inside the AccessTime register bit field.
- (4) $P = \text{PageBurstAccessTime} \times (\text{TimeParaGranularity} + 1) \times \text{GPMC_FCLK}^{(6)}$
- (5) $H = \text{AccessTime} \times (\text{TimeParaGranularity} + 1) \times \text{GPMC_FCLK}^{(6)}$
- (6) GPMC_FCLK is a general-purpose memory controller internal functional clock period in ns.

Table 6-61. GPMC and NOR Flash Switching Characteristics – Asynchronous Mode

see Figure 6-44, Figure 6-45, Figure 6-46, Figure 6-47, Figure 6-48, and Figure 6-49

| NO. | PARAMETER | DESCRIPTION | MIN | MAX | UNIT |
|------|------------------------------|--|-------------------------|-------------------------|------|
| FA0 | t _{w(be[x]nV)} | Pulse duration, output lower-byte enable and command latch enable GPMC_BE0n_CLE, output upper-byte enable GPMC_BE1n valid time | | N ⁽¹²⁾ | ns |
| FA1 | t _{w(csnV)} | Pulse duration, output chip select GPMC_CS <i>n</i> [<i>ij</i>] ⁽¹³⁾ low | | A ⁽¹⁾ | ns |
| FA3 | t _{d(csnV-advnV)} | Delay time, output chip select GPMC_CS <i>n</i> [<i>ij</i>] ⁽¹³⁾ valid to output address valid and address latch enable GPMC_ADV <i>n</i> _ALE invalid | B ⁽²⁾ - 2.1 | B ⁽²⁾ + 2.1 | ns |
| FA4 | t _{d(csnV-oenV)} | Delay time, output chip select GPMC_CS <i>n</i> [<i>ij</i>] ⁽¹³⁾ valid to output enable GPMC_OEn_RE <i>n</i> invalid (Single read) | C ⁽³⁾ - 2.1 | C ⁽³⁾ + 2.1 | ns |
| FA9 | t _{d(aV-csnV)} | Delay time, output address GPMC_A[27:1] valid to output chip select GPMC_CS <i>n</i> [<i>ij</i>] ⁽¹³⁾ valid | J ⁽⁹⁾ - 2.1 | J ⁽⁹⁾ + 2.1 | ns |
| FA10 | t _{d(be[x]nV-csnV)} | Delay time, output lower-byte enable and command latch enable GPMC_BE0n_CLE, output upper-byte enable GPMC_BE1n valid to output chip select GPMC_CS <i>n</i> [<i>ij</i>] ⁽¹³⁾ valid | J ⁽⁹⁾ - 2.1 | J ⁽⁹⁾ + 2.1 | ns |
| FA12 | t _{d(csnV-advnV)} | Delay time, output chip select GPMC_CS <i>n</i> [<i>ij</i>] ⁽¹³⁾ valid to output address valid and address latch enable GPMC_ADV <i>n</i> _ALE valid | K ⁽¹⁰⁾ - 2.1 | K ⁽¹⁰⁾ + 2.1 | ns |
| FA13 | t _{d(csnV-oenV)} | Delay time, output chip select GPMC_CS <i>n</i> [<i>ij</i>] ⁽¹³⁾ valid to output enable GPMC_OEn_RE <i>n</i> valid | L ⁽¹¹⁾ - 2.1 | L ⁽¹¹⁾ + 2.1 | ns |
| FA16 | t _{w(alV)} | Pulse duration output address GPMC_A[26:1] invalid between 2 successive read and write accesses | | G ⁽⁷⁾ | ns |
| FA18 | t _{d(csnV-oenV)} | Delay time, output chip select GPMC_CS <i>n</i> [<i>ij</i>] ⁽¹³⁾ valid to output enable GPMC_OEn_RE <i>n</i> invalid (Burst read) | I ⁽⁸⁾ - 2.1 | I ⁽⁸⁾ + 2.1 | ns |
| FA20 | t _{w(aV)} | Pulse duration, output address GPMC_A[27:1] valid - 2nd, 3rd, and 4th accesses | | D ⁽⁴⁾ | ns |
| FA25 | t _{d(csnV-wenV)} | Delay time, output chip select GPMC_CS <i>n</i> [<i>ij</i>] ⁽¹³⁾ valid to output write enable GPMC_WEn valid | E ⁽⁵⁾ - 2.1 | E ⁽⁵⁾ + 2.1 | ns |
| FA27 | t _{d(csnV-wenV)} | Delay time, output chip select GPMC_CS <i>n</i> [<i>ij</i>] ⁽¹³⁾ valid to output write enable GPMC_WEn invalid | F ⁽⁶⁾ - 2.1 | F ⁽⁶⁾ + 2.1 | ns |
| FA28 | t _{d(wenV-dV)} | Delay time, output write enable GPMC_WEn valid to output data GPMC_AD[15:0] valid | | 2.1 | ns |

Table 6-61. GPMC and NOR Flash Switching Characteristics – Asynchronous Mode (continued)

see [Figure 6-44](#), [Figure 6-45](#), [Figure 6-46](#), [Figure 6-47](#), [Figure 6-48](#), and [Figure 6-49](#)

| NO. | PARAMETER | DESCRIPTION | MIN | MAX | UNIT |
|------|-------------------|---|-----------------|-----------------|------|
| FA29 | $t_{d(dV-csnV)}$ | Delay time, output data GPMC_AD[15:0] valid to output chip select GPMC_CS <i>n</i> [<i>j</i>] ⁽¹³⁾ valid | $J^{(9)} - 2.1$ | $J^{(9)} + 2.1$ | ns |
| FA37 | $t_{d(oenV-aIV)}$ | Delay time, output enable GPMC_OEn_RE <i>n</i> valid to output address GPMC_AD[15:0] phase end | | 2.1 | ns |

- (1) For single read: $A = (CSRdOffTime - CSOnTime) \times (TimeParaGranularity + 1) \times GPMC_FCLK^{(14)}$
 For single write: $A = (CSWrOffTime - CSOnTime) \times (TimeParaGranularity + 1) \times GPMC_FCLK^{(14)}$
 For burst read: $A = (CSRdOffTime - CSOnTime + (n - 1) \times PageBurstAccessTime) \times (TimeParaGranularity + 1) \times GPMC_FCLK^{(14)}$
 For burst write: $A = (CSWrOffTime - CSOnTime + (n - 1) \times PageBurstAccessTime) \times (TimeParaGranularity + 1) \times GPMC_FCLK^{(14)}$
 with n being the page burst access number
- (2) For reading: $B = ((ADVRdOffTime - CSOnTime) \times (TimeParaGranularity + 1) + 0.5 \times (ADVExtraDelay - CSEExtraDelay)) \times GPMC_FCLK^{(14)}$
 For writing: $B = ((ADVWrOffTime - CSOnTime) \times (TimeParaGranularity + 1) + 0.5 \times (ADVExtraDelay - CSEExtraDelay)) \times GPMC_FCLK^{(14)}$
- (3) $C = ((OEOffTime - CSOnTime) \times (TimeParaGranularity + 1) + 0.5 \times (OEEExtraDelay - CSEExtraDelay)) \times GPMC_FCLK^{(14)}$
- (4) $D = PageBurstAccessTime \times (TimeParaGranularity + 1) \times GPMC_FCLK^{(14)}$
- (5) $E = ((WEOnTime - CSOnTime) \times (TimeParaGranularity + 1) + 0.5 \times (WEEExtraDelay - CSEExtraDelay)) \times GPMC_FCLK^{(14)}$
- (6) $F = ((WEOffTime - CSOnTime) \times (TimeParaGranularity + 1) + 0.5 \times (WEEExtraDelay - CSEExtraDelay)) \times GPMC_FCLK^{(14)}$
- (7) $G = Cycle2CycleDelay \times GPMC_FCLK^{(14)}$
- (8) $I = ((OEOffTime + (n - 1) \times PageBurstAccessTime - CSOnTime) \times (TimeParaGranularity + 1) + 0.5 \times (OEEExtraDelay - CSEExtraDelay)) \times GPMC_FCLK^{(14)}$
- (9) $J = (CSOnTime \times (TimeParaGranularity + 1) + 0.5 \times CSEExtraDelay) \times GPMC_FCLK^{(14)}$
- (10) $K = ((ADVOnTime - CSOnTime) \times (TimeParaGranularity + 1) + 0.5 \times (ADVExtraDelay - CSEExtraDelay)) \times GPMC_FCLK^{(14)}$
- (11) $L = ((OEOnTime - CSOnTime) \times (TimeParaGranularity + 1) + 0.5 \times (OEEExtraDelay - CSEExtraDelay)) \times GPMC_FCLK^{(14)}$
- (12) For single read: $N = RdCycleTime \times (TimeParaGranularity + 1) \times GPMC_FCLK^{(14)}$
 For single write: $N = WrCycleTime \times (TimeParaGranularity + 1) \times GPMC_FCLK^{(14)}$
 For burst read: $N = (RdCycleTime + (n - 1) \times PageBurstAccessTime) \times (TimeParaGranularity + 1) \times GPMC_FCLK^{(14)}$
 For burst write: $N = (WrCycleTime + (n - 1) \times PageBurstAccessTime) \times (TimeParaGranularity + 1) \times GPMC_FCLK^{(14)}$
- (13) In GPMC_CS*n*[*i*], i is equal to 0, 1, 2 or 3.
- (14) GPMC_FCLK is general-purpose memory controller internal functional clock period in ns.

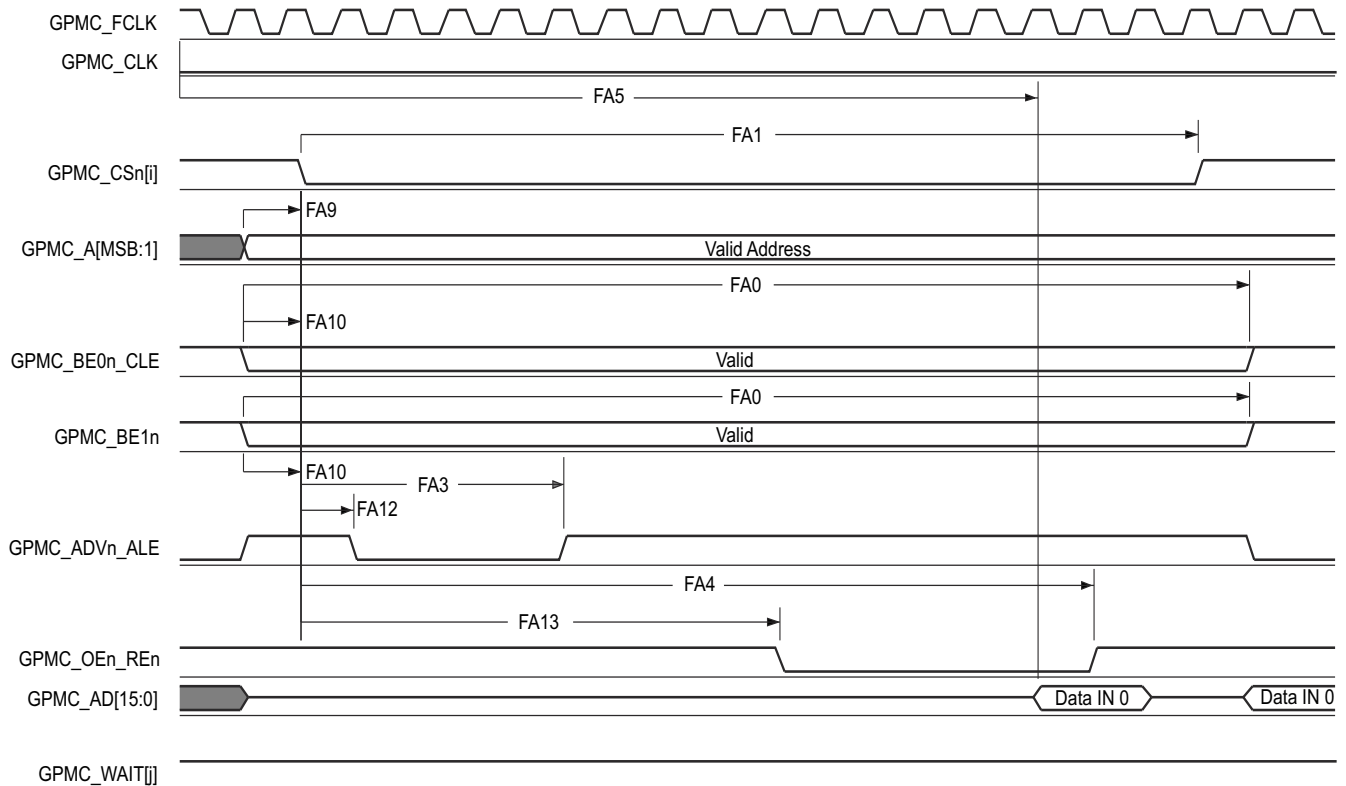

GPMC_06

A. In GPMC_CS*n*[*i*], i is equal to 0, 1, 2 or 3. In GPMC_WAIT[j], j is equal to 0 or 1.

- B. FA5 parameter illustrates amount of time required to internally sample input data. It is expressed in number of GPMC functional clock cycles. From start of read cycle and after FA5 functional clock cycles, input data will be internally sampled by active functional clock edge. FA5 value must be stored inside AccessTime register bits field.
- C. GPMC_FCLK is an internal clock (GPMC functional clock) not provided externally.

Figure 6-44. GPMC and NOR Flash — Asynchronous Read — Single Word

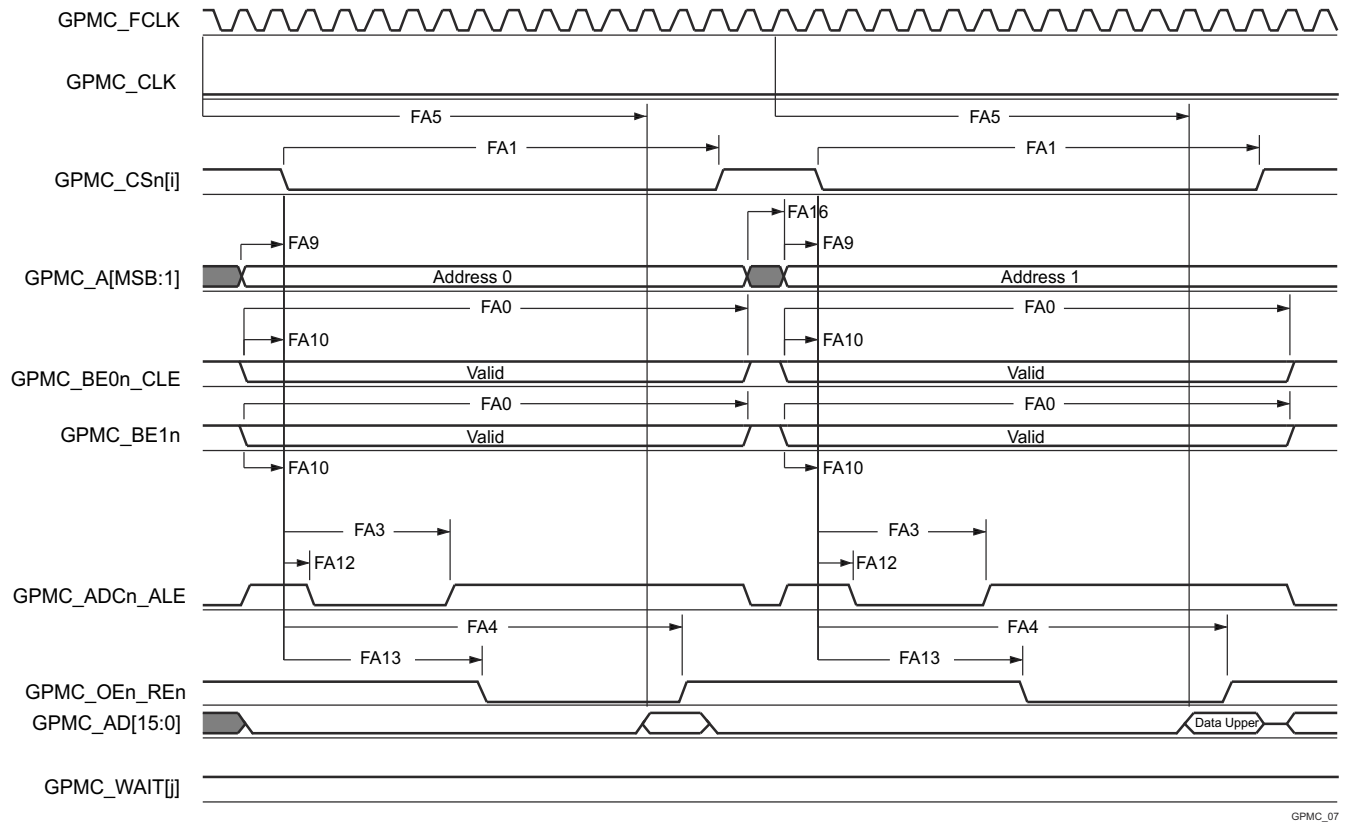

GPMC_07

- A. In GPMC_CSn[i], i is equal to 0, 1, 2 or 3. In GPMC_WAIT[j], j is equal to 0 or 1.
- B. FA5 parameter illustrates amount of time required to internally sample input data. It is expressed in number of GPMC functional clock cycles. From start of read cycle and after FA5 functional clock cycles, input data will be internally sampled by active functional clock edge. FA5 value must be stored inside AccessTime register bits field.
- C. GPMC_FCLK is an internal clock (GPMC functional clock) not provided externally.

Figure 6-45. GPMC and NOR Flash — Asynchronous Read — 32-Bit

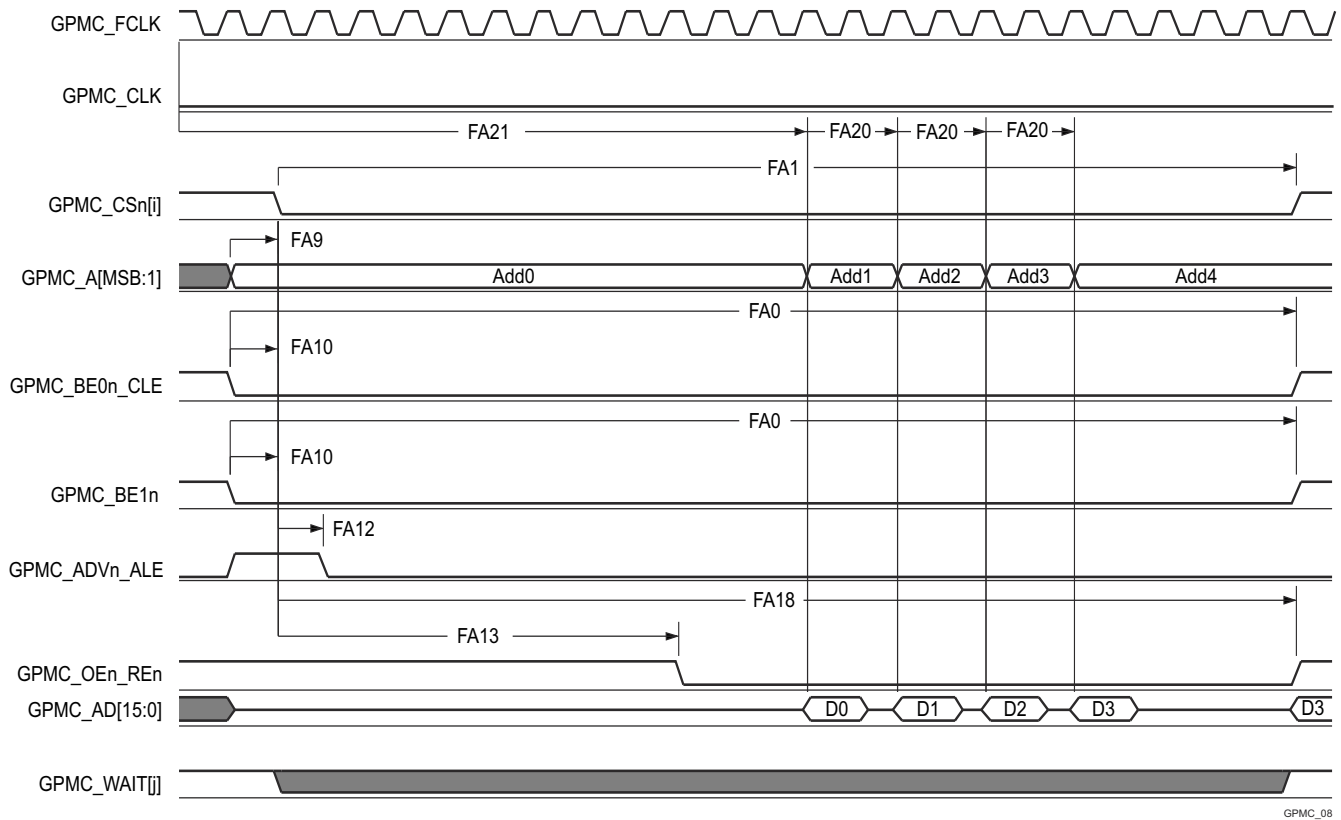

GPMC_08

- A. In GPMC_CS*n*[*i*], *i* is equal to 0, 1, 2 or 3. In GPMC_WAIT[j], *j* is equal to 0 or 1.
- B. FA21 parameter illustrates amount of time required to internally sample first input page data. It is expressed in number of GPMC functional clock cycles. From start of read cycle and after FA21 functional clock cycles, first input page data will be internally sampled by active functional clock edge. FA21 calculation must be stored inside AccessTime register bits field.
- C. FA20 parameter illustrates amount of time required to internally sample successive input page data. It is expressed in number of GPMC functional clock cycles. After each access to input page data, next input page data will be internally sampled by active functional clock edge after FA20 functional clock cycles. FA20 is also the duration of address phases for successive input page data (excluding first input page data). FA20 value must be stored in PageBurstAccessTime register bits field.
- D. GPMC_FCLK is an internal clock (GPMC functional clock) not provided externally.

Figure 6-46. GPMC and NOR Flash — Asynchronous Read — Page Mode 4x16-Bit

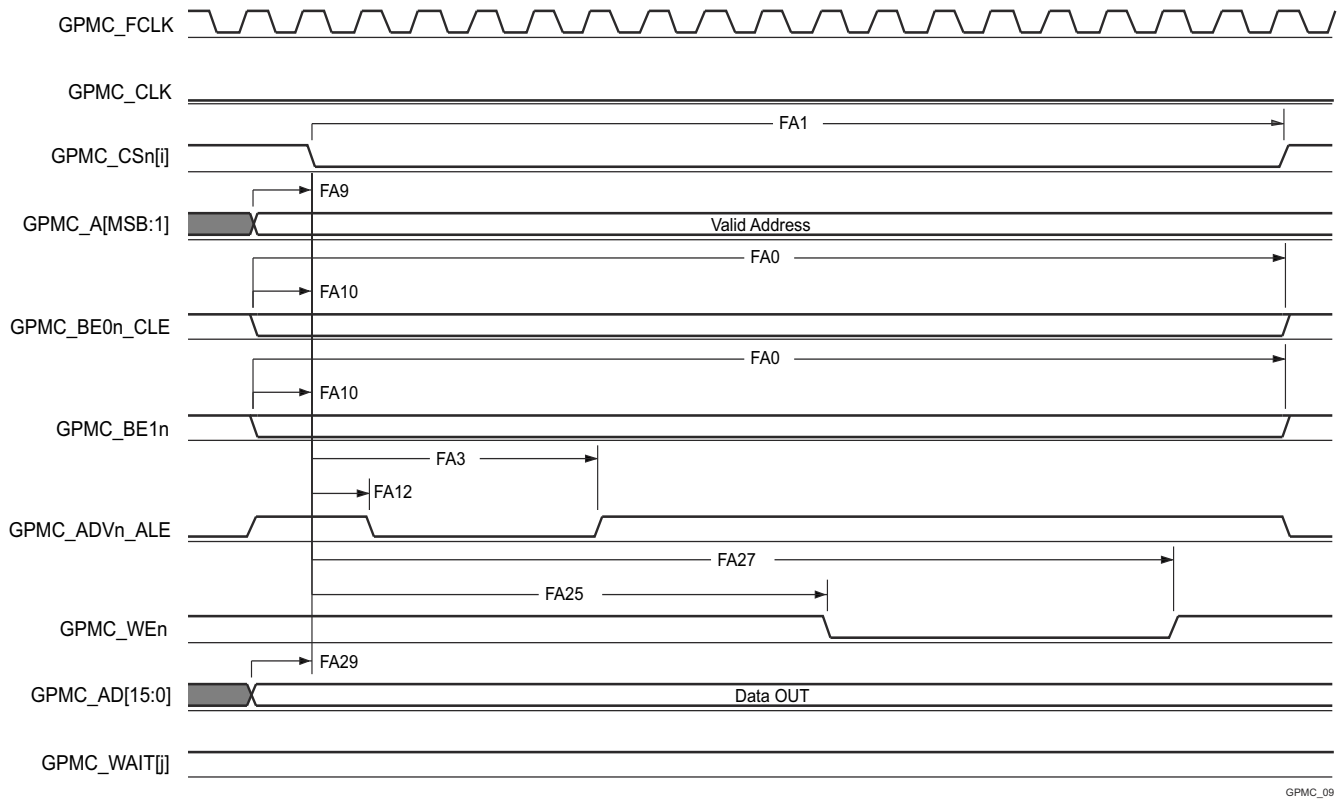

GPMC_09

A. In GPMC_CSn[i], i is equal to 0, 1, 2 or 3. In GPMC_WAIT[j], j is equal to 0 or 1.

Figure 6-47. GPMC and NOR Flash — Asynchronous Write — Single Word

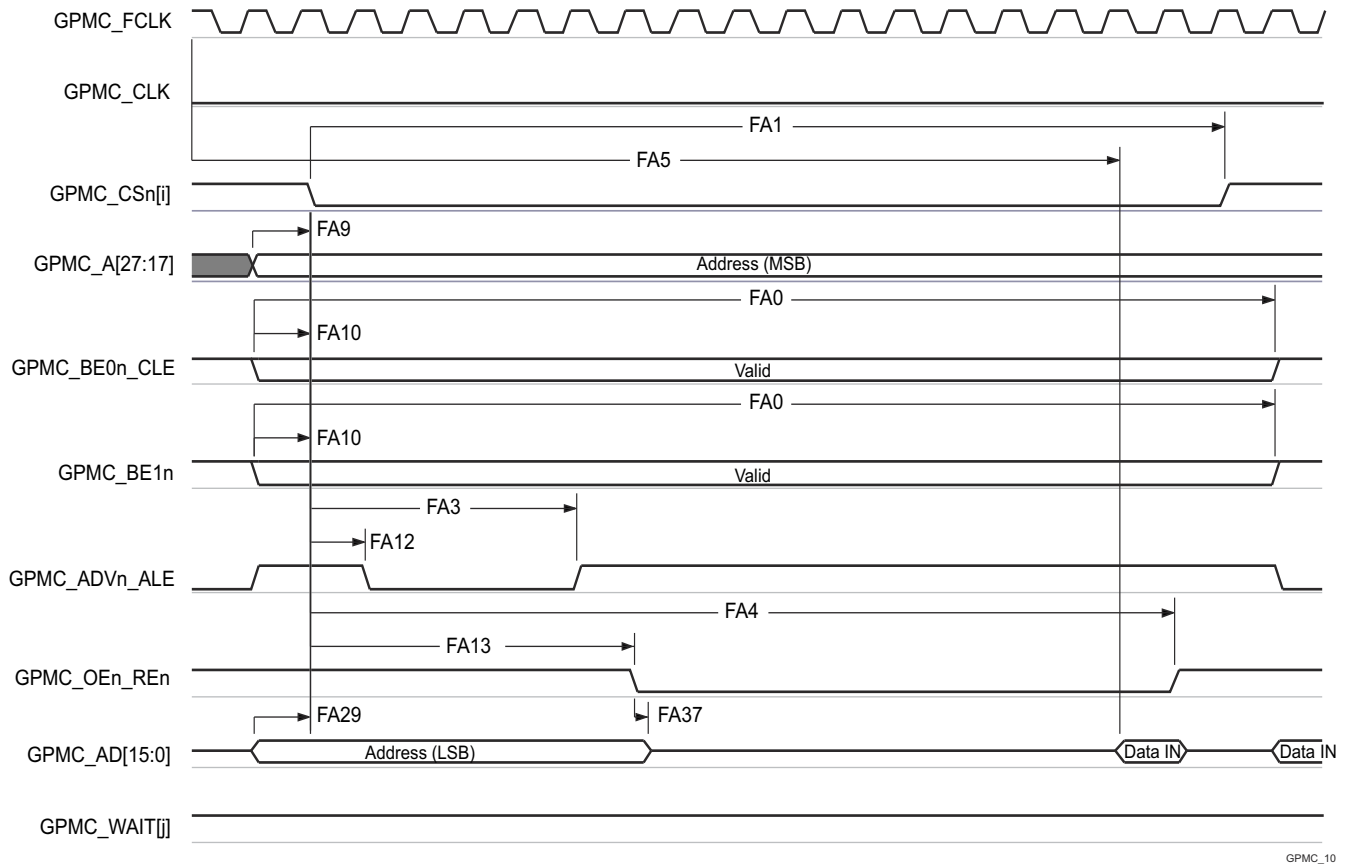

GPMC_10

- A. In GPMC_CSn[i], i is equal to 0, 1, 2 or 3. In GPMC_WAIT[j], j is equal to 0 or 1.
- B. FA5 parameter illustrates amount of time required to internally sample input data. It is expressed in number of GPMC functional clock cycles. From start of read cycle and after FA5 functional clock cycles, input data will be internally sampled by active functional clock edge. FA5 value must be stored inside AccessTime register bits field.
- C. GPMC_FCLK is an internal clock (GPMC functional clock) not provided externally.

Figure 6-48. GPMC and Multiplexed NOR Flash — Asynchronous Read — Single Word

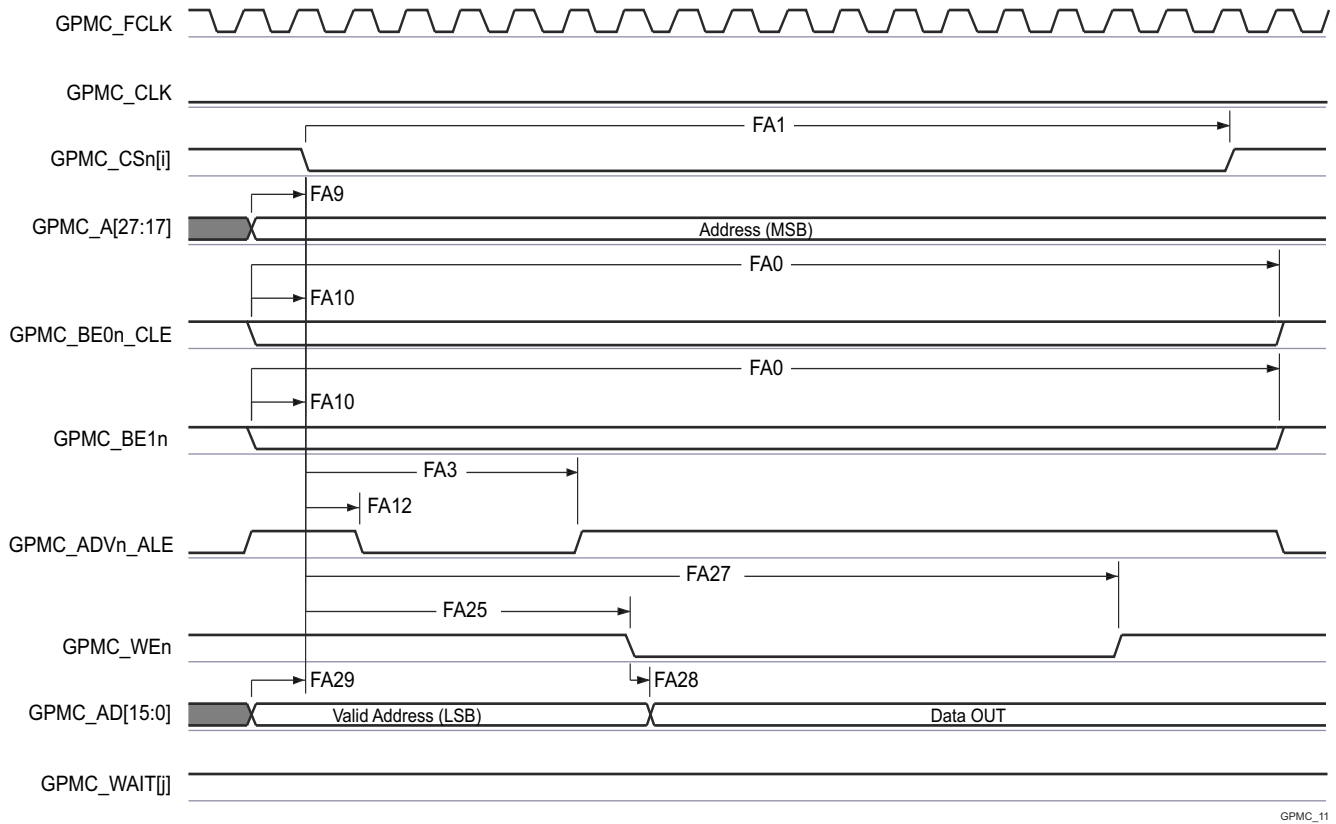

GPMC_11

A. In $GPMC_CSn[i]$, i is equal to 0, 1, 2 or 3. In $GPMC_WAIT[j]$, j is equal to 0 or 1.

Figure 6-49. GPMC and Multiplexed NOR Flash — Asynchronous Write — Single Word

6.11.5.8.3 GPMC and NAND Flash — Asynchronous Mode

Table 6-62 and Table 6-63 present timing requirements and switching characteristics for GPMC and NAND Flash — Asynchronous Mode.

Table 6-62. GPMC and NAND Flash Timing Requirements – Asynchronous Mode

see Figure 6-52

| NO. | PARAMETER | DESCRIPTION | MIN | MAX | UNIT |
|----------------------|--------------|--|-----|------------------|------|
| GNF12 ⁽¹⁾ | $t_{acc(d)}$ | Access time, input data GPMC_AD[15:0] ⁽³⁾ | | J ⁽²⁾ | ns |

- (1) The GNF12 parameter illustrates the amount of time required to internally sample input data. It is expressed in number of GPMC functional clock cycles. From start of the read cycle and after GNF12 functional clock cycles, input data is internally sampled by the active functional clock edge. The GNF12 value must be stored inside AccessTime register bit field.
- (2) $J = \text{AccessTime} \times (\text{TimeParaGranularity} + 1) \times \text{GPMC_FCLK}^{(3)}$
- (3) GPMC_FCLK is general-purpose memory controller internal functional clock period in ns.

Table 6-63. GPMC and NAND Flash Switching Characteristics – Asynchronous Mode

see Figure 6-50, Figure 6-51, Figure 6-52 and Figure 6-53

| NO. | PARAMETER | DESCRIPTION | MIN | MAX | UNIT |
|-------|------------------------|---|-----------------------|-----------------------|------|
| GNF0 | $t_{w(wenV)}$ | Pulse duration, output write enable GPMC_WEn valid | A ⁽¹⁾ | | ns |
| GNF1 | $t_{d(csnV-wenV)}$ | Delay time, output chip select GPMC_CS[n] ⁽¹³⁾ valid to output write enable GPMC_WEn valid | B ⁽²⁾ - 2 | B ⁽²⁾ + 2 | ns |
| GNF2 | $t_{w(cleH-wenV)}$ | Delay time, output lower-byte enable and command latch enable GPMC_BE0n_CLE high to output write enable GPMC_WEn valid | C ⁽³⁾ - 2 | C ⁽³⁾ + 2 | ns |
| GNF3 | $t_{w(wenV-dV)}$ | Delay time, output data GPMC_AD[15:0] valid to output write enable GPMC_WEn valid | D ⁽⁴⁾ - 2 | D ⁽⁴⁾ + 2 | ns |
| GNF4 | $t_{w(wenIV-dIV)}$ | Delay time, output write enable GPMC_WEn invalid to output data GPMC_AD[15:0] invalid | E ⁽⁵⁾ - 2 | E ⁽⁵⁾ + 2 | ns |
| GNF5 | $t_{w(wenIV-cleIV)}$ | Delay time, output write enable GPMC_WEn invalid to output lower-byte enable and command latch enable GPMC_BE0n_CLE invalid | F ⁽⁶⁾ - 2 | F ⁽⁶⁾ + 2 | ns |
| GNF6 | $t_{w(wenIV-csn[j]V)}$ | Delay time, output write enable GPMC_WEn invalid to output chip select GPMC_CS[n] ⁽¹³⁾ invalid | G ⁽⁷⁾ - 2 | G ⁽⁷⁾ + 2 | ns |
| GNF7 | $t_{w(aleH-wenV)}$ | Delay time, output address valid and address latch enable GPMC_ADVn_ALE high to output write enable GPMC_WEn valid | C ⁽³⁾ - 2 | C ⁽³⁾ + 2 | ns |
| GNF8 | $t_{w(wenIV-aleIV)}$ | Delay time, output write enable GPMC_WEn invalid to output address valid and address latch enable GPMC_ADVn_ALE invalid | F ⁽⁶⁾ - 2 | F ⁽⁶⁾ + 2 | ns |
| GNF9 | $t_{c(wen)}$ | Cycle time, write | | H ⁽⁸⁾ | ns |
| GNF10 | $t_{d(csnV-oenV)}$ | Delay time, output chip select GPMC_CS[n] ⁽¹³⁾ valid to output enable GPMC_OEn_REn valid | I ⁽⁹⁾ - 2 | I ⁽⁹⁾ + 2 | ns |
| GNF13 | $t_{w(oenV)}$ | Pulse duration, output enable GPMC_OEn_REn valid | | K ⁽¹⁰⁾ | ns |
| GNF14 | $t_{c(oen)}$ | Cycle time, read | L ⁽¹¹⁾ | | ns |
| GNF15 | $t_{w(oenIV-csn[j]V)}$ | Delay time, output enable GPMC_OEn_REn invalid to output chip select GPMC_CS[n] ⁽¹³⁾ invalid | M ⁽¹²⁾ - 2 | M ⁽¹²⁾ + 2 | ns |

- (1) $A = (\text{WEOffTime} - \text{WEOnTime}) \times (\text{TimeParaGranularity} + 1) \times \text{GPMC_FCLK}^{(14)}$
- (2) $B = ((\text{WEOnTime} - \text{CSOnTime}) \times (\text{TimeParaGranularity} + 1) + 0.5 \times (\text{WEEExtraDelay} - \text{CSEExtraDelay})) \times \text{GPMC_FCLK}^{(14)}$
- (3) $C = ((\text{WEOnTime} - \text{ADVOnTime}) \times (\text{TimeParaGranularity} + 1) + 0.5 \times (\text{WEEExtraDelay} - \text{ADVExtraDelay})) \times \text{GPMC_FCLK}^{(14)}$ Note: For DeviceType: NAND
- During Command Latch Cycle: CLE signal is controlled by the ADVOnTime and ADVWrOffTime timing parameters
 - During Address Latch Cycle: ALE signal is controlled by the ADVOnTime and ADVWrOffTime timing parameters.
- (4) $D = (\text{WEOnTime} \times (\text{TimeParaGranularity} + 1) + 0.5 \times \text{WEEExtraDelay}) \times \text{GPMC_FCLK}^{(14)}$
- (5) $E = ((\text{WrCycleTime} - \text{WEOffTime}) \times (\text{TimeParaGranularity} + 1) - 0.5 \times \text{WEEExtraDelay}) \times \text{GPMC_FCLK}^{(14)}$
- (6) $F = ((\text{ADVWrOffTime} - \text{WEOffTime}) \times (\text{TimeParaGranularity} + 1) + 0.5 \times (\text{ADVExtraDelay} - \text{WEEExtraDelay})) \times \text{GPMC_FCLK}^{(14)}$ Note: For DeviceType: NAND
- During Command Latch Cycle: CLE signal is controlled by the ADVOnTime and ADVWrOffTime timing parameters
 - During Address Latch Cycle: ALE signal is controlled by the ADVOnTime and ADVWrOffTime timing parameters.
- (7) $G = ((\text{CSWrOffTime} - \text{WEOffTime}) \times (\text{TimeParaGranularity} + 1) + 0.5 \times (\text{CSEExtraDelay} - \text{WEEExtraDelay})) \times \text{GPMC_FCLK}^{(14)}$
- (8) $H = \text{WrCycleTime} \times (1 + \text{TimeParaGranularity}) \times \text{GPMC_FCLK}^{(14)}$

- (9) $I = ((OEOnTime - CSONTime) \times (TimeParaGranularity + 1) + 0.5 \times (OEEExtraDelay - CSEExtraDelay)) \times GPMC_FCLK^{(14)}$
- (10) $K = (OEOffTime - OEOnTime) \times (1 + TimeParaGranularity) \times GPMC_FCLK^{(14)}$
- (11) $L = RdCycleTime \times (1 + TimeParaGranularity) \times GPMC_FCLK^{(14)}$
- (12) $M = ((CSRdOffTime - OEOffTime) \times (TimeParaGranularity + 1) + 0.5 \times (CSEExtraDelay - OEEExtraDelay)) \times GPMC_FCLK^{(14)}$
- (13) In GPMC_CS*n*[*i*], *i* is equal to 0, 1, 2 or 3.
- (14) GPMC_FCLK is general-purpose memory controller internal functional clock period in ns.

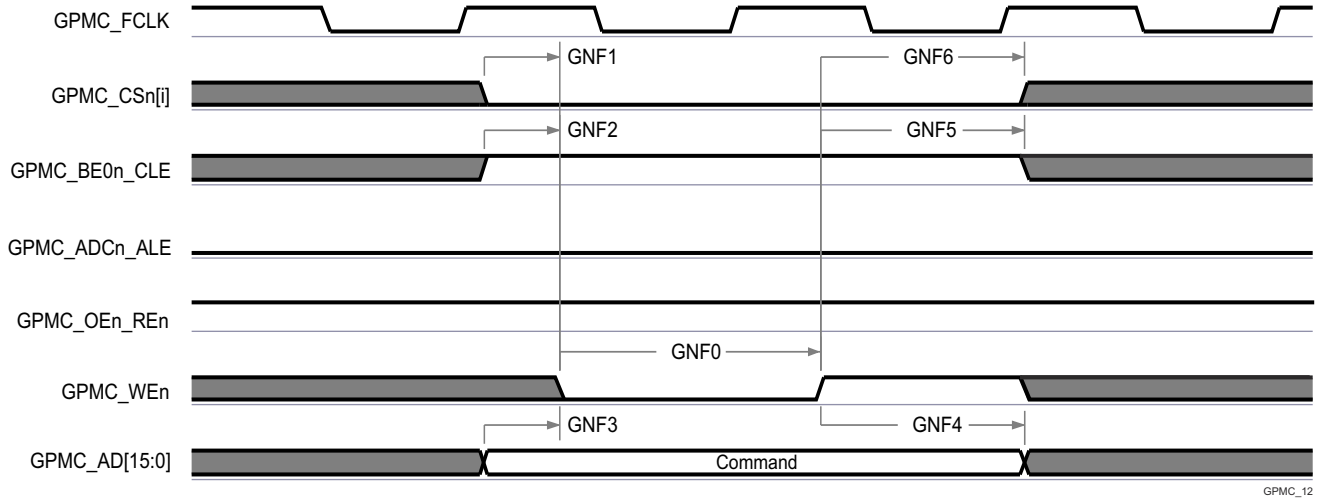

A. In GPMC_CS*n*[*i*], *i* is equal to 0, 1, 2 or 3.

Figure 6-50. GPMC and NAND Flash — Command Latch Cycle

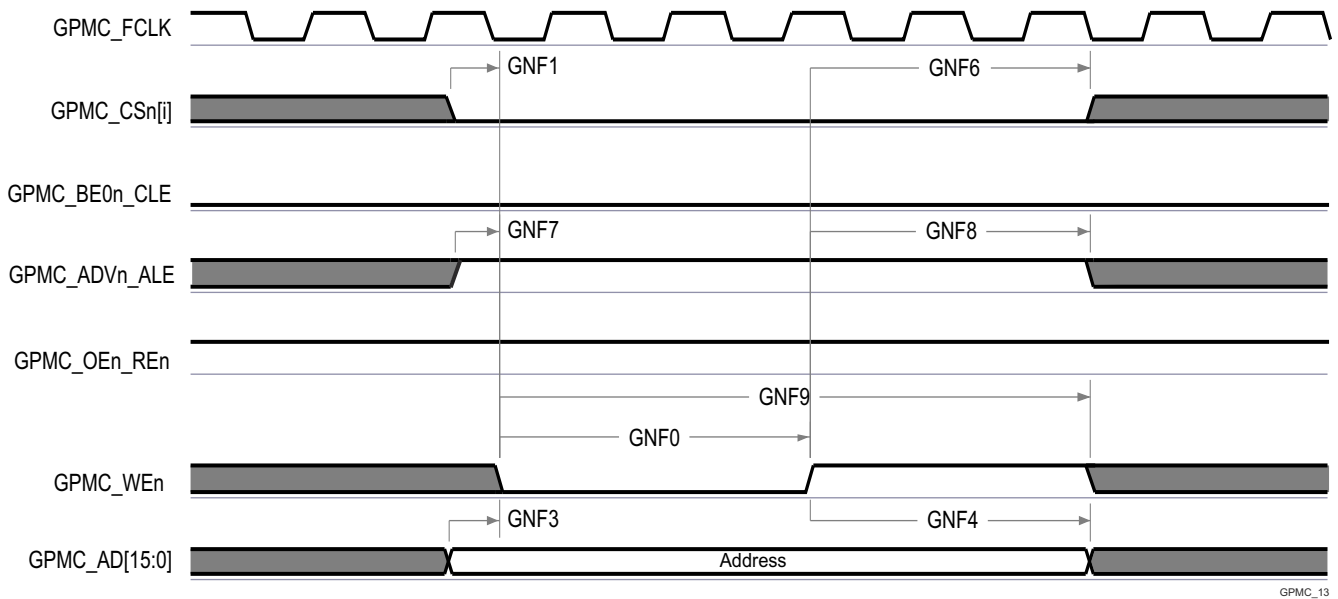

A. In GPMC_CS*n*[*i*], *i* is equal to 0, 1, 2 or 3.

Figure 6-51. GPMC and NAND Flash — Address Latch Cycle

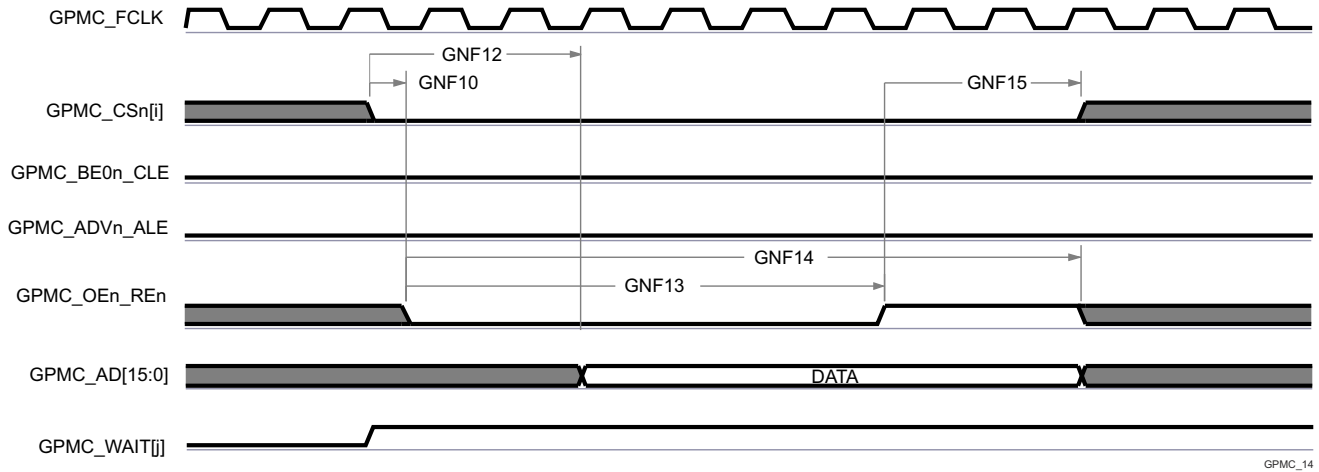

GPMC_14

- A. GNF12 parameter illustrates amount of time required to internally sample input data. It is expressed in number of GPMC functional clock cycles. From start of read cycle and after GNF12 functional clock cycles, input data will be internally sampled by active functional clock edge. GNF12 value must be stored inside AccessTime register bits field.
- B. GPMC_FCLK is an internal clock (GPMC functional clock) not provided externally.
- C. In GPMC_CSn[i], i is equal to 0, 1, 2 or 3. In GPMC_WAIT[j], j is equal to 0 or 1.

Figure 6-52. GPMC and NAND Flash — Data Read Cycle

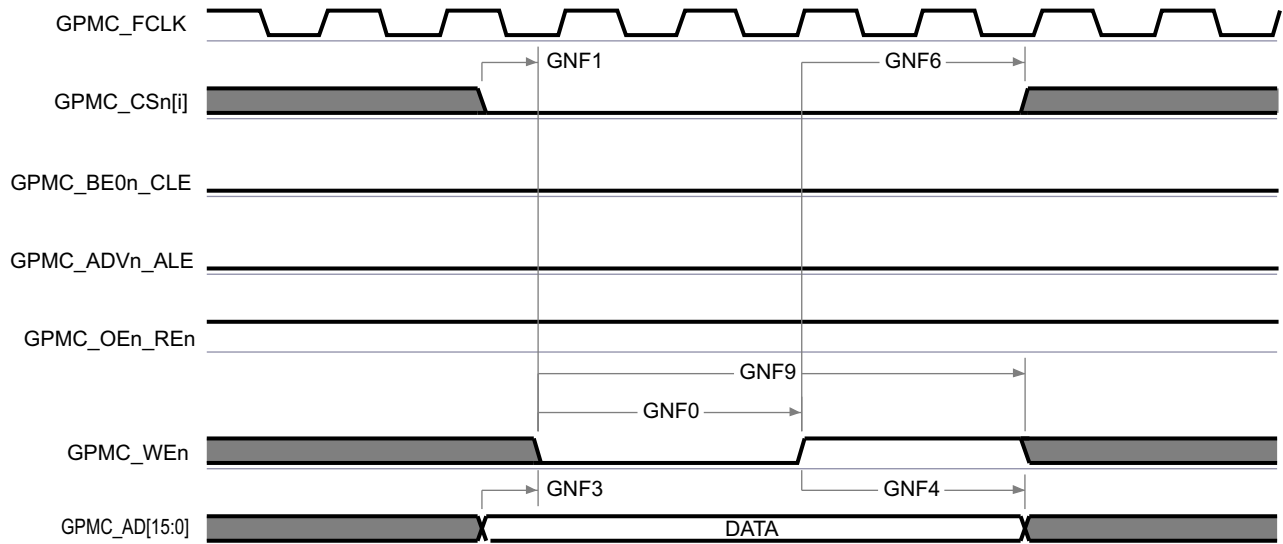

GPMC_15

- A. In GPMC_CSn[i], i is equal to 0, 1, 2 or 3.

Figure 6-53. GPMC and NAND Flash — Data Write Cycle

6.11.5.8.4 GPMC0 IOSETs (ALV/ANI)

Table 6-64 defines valid pin combinations of each ALV/ANI package GPMC0 IOSET.

Table 6-64. GPMC0 IOSETs (ALV/ANI)

| SIGNALS | IOSET1 | | IOSET2 | |
|----------------|---------------------|---------|---------------------|---------|
| | BALL NAME (ALV/ANI) | MUXMODE | BALL NAME (ALV/ANI) | MUXMODE |
| GPMC0_AD0 | GPMC0_AD0 | 0 | GPMC0_AD0 | 0 |
| GPMC0_AD1 | GPMC0_AD1 | 0 | GPMC0_AD1 | 0 |
| GPMC0_AD2 | GPMC0_AD2 | 0 | GPMC0_AD2 | 0 |
| GPMC0_AD3 | GPMC0_AD3 | 0 | GPMC0_AD3 | 0 |
| GPMC0_AD4 | GPMC0_AD4 | 0 | GPMC0_AD4 | 0 |
| GPMC0_AD5 | GPMC0_AD5 | 0 | GPMC0_AD5 | 0 |
| GPMC0_AD6 | GPMC0_AD6 | 0 | GPMC0_AD6 | 0 |
| GPMC0_AD7 | GPMC0_AD7 | 0 | GPMC0_AD7 | 0 |
| GPMC0_AD8 | GPMC0_AD8 | 0 | GPMC0_AD8 | 0 |
| GPMC0_AD9 | GPMC0_AD9 | 0 | GPMC0_AD9 | 0 |
| GPMC0_AD10 | GPMC0_AD10 | 0 | GPMC0_AD10 | 0 |
| GPMC0_AD11 | GPMC0_AD11 | 0 | GPMC0_AD11 | 0 |
| GPMC0_AD12 | GPMC0_AD12 | 0 | GPMC0_AD12 | 0 |
| GPMC0_AD13 | GPMC0_AD13 | 0 | GPMC0_AD13 | 0 |
| GPMC0_AD14 | GPMC0_AD14 | 0 | GPMC0_AD14 | 0 |
| GPMC0_AD15 | GPMC0_AD15 | 0 | GPMC0_AD15 | 0 |
| GPMC0_CLK | GPMC0_CLK | 0 | GPMC0_CLK | 0 |
| GPMC0_ADVn_ALE | GPMC0_ADVn_ALE | 0 | GPMC0_ADVn_ALE | 0 |
| GPMC0_OEn_REn | GPMC0_OEn_REn | 0 | GPMC0_OEn_REn | 0 |
| GPMC0_WEn | GPMC0_WEn | 0 | GPMC0_WEn | 0 |
| GPMC0_BE0n_CLE | GPMC0_BE0n_CLE | 0 | GPMC0_BE0n_CLE | 0 |
| GPMC0_BE1n | GPMC0_BE1n | 0 | GPMC0_BE1n | 0 |
| GPMC0_WAIT0 | GPMC0_WAIT0 | 0 | GPMC0_WAIT0 | 0 |
| GPMC0_WAIT1 | GPMC0_WAIT1 | 0 | GPMC0_WAIT1 | 0 |
| GPMC0_WPn | GPMC0_WPn | 0 | GPMC0_WPn | 0 |
| GPMC0_DIR | GPMC0_DIR | 0 | GPMC0_DIR | 0 |
| GPMC0_CSn0 | GPMC0_CSn0 | 0 | GPMC0_CSn0 | 0 |
| GPMC0_CSn1 | GPMC0_CSn1 | 0 | GPMC0_CSn1 | 0 |
| GPMC0_CSn2 | GPMC0_CSn2 | 0 | GPMC0_CSn2 | 0 |
| GPMC0_CSn3 | GPMC0_CSn3 | 0 | GPMC0_CSn3 | 0 |
| GPMC0_AD16 | PRG1_PRU0_GPO0 | 8 | PRG1_PRU0_GPO0 | 8 |
| GPMC0_AD17 | PRG1_PRU0_GPO1 | 8 | PRG1_PRU0_GPO1 | 8 |
| GPMC0_AD18 | PRG1_PRU0_GPO2 | 8 | PRG1_PRU0_GPO2 | 8 |
| GPMC0_AD19 | PRG1_PRU0_GPO3 | 8 | PRG1_PRU0_GPO3 | 8 |
| GPMC0_AD20 | PRG1_PRU0_GPO4 | 8 | PRG1_PRU0_GPO4 | 8 |
| GPMC0_AD21 | PRG1_PRU0_GPO5 | 8 | PRG1_PRU0_GPO5 | 8 |
| GPMC0_AD22 | PRG1_PRU0_GPO6 | 8 | PRG1_PRU0_GPO6 | 8 |
| GPMC0_AD23 | PRG1_PRU0_GPO7 | 8 | PRG1_PRU0_GPO7 | 8 |
| GPMC0_AD24 | PRG1_PRU0_GPO8 | 8 | PRG1_PRU0_GPO8 | 8 |
| GPMC0_AD25 | PRG1_PRU0_GPO9 | 8 | PRG1_PRU0_GPO9 | 8 |
| GPMC0_AD26 | PRG1_PRU0_GPO10 | 8 | PRG1_PRU0_GPO10 | 8 |

Table 6-64. GPMC0 IOSETs (ALV/ANI) (continued)

| SIGNALS | IOSET1 | | IOSET2 | |
|------------|---------------------|---------|---------------------|---------|
| | BALL NAME (ALV/ANI) | MUXMODE | BALL NAME (ALV/ANI) | MUXMODE |
| GPMC0_AD27 | PRG1_PRU0_GPO11 | 8 | PRG1_PRU0_GPO11 | 8 |
| GPMC0_AD28 | PRG1_PRU0_GPO12 | 8 | PRG1_PRU0_GPO12 | 8 |
| GPMC0_AD29 | PRG1_PRU0_GPO13 | 8 | PRG1_PRU0_GPO13 | 8 |
| GPMC0_AD30 | PRG1_PRU0_GPO14 | 8 | PRG1_PRU0_GPO14 | 8 |
| GPMC0_AD31 | PRG1_PRU0_GPO15 | 8 | PRG1_PRU0_GPO15 | 8 |
| GPMC0_BE2n | PRG1_PRU0_GPO16 | 8 | PRG1_PRU0_GPO16 | 8 |
| GPMC0_A0 | PRG1_PRU0_GPO17 | 8 | PRG0_PRU0_GPO2 | 9 |
| GPMC0_A1 | PRG1_PRU0_GPO18 | 8 | PRG0_PRU0_GPO4 | 9 |
| GPMC0_A2 | PRG1_PRU0_GPO19 | 8 | PRG0_PRU0_GPO8 | 9 |
| GPMC0_A3 | PRG1_PRU1_GPO0 | 8 | PRG0_PRU0_GPO14 | 9 |
| GPMC0_A4 | PRG1_PRU1_GPO1 | 8 | PRG0_PRU0_GPO16 | 9 |
| GPMC0_A5 | PRG1_PRU1_GPO2 | 8 | PRG0_PRU0_GPO18 | 9 |
| GPMC0_A6 | PRG1_PRU1_GPO3 | 8 | PRG0_PRU0_GPO19 | 9 |
| GPMC0_A7 | PRG1_PRU1_GPO4 | 8 | PRG0_PRU1_GPO12 | 9 |
| GPMC0_A8 | PRG1_PRU1_GPO5 | 8 | PRG0_PRU1_GPO13 | 9 |
| GPMC0_A9 | PRG1_PRU1_GPO6 | 8 | PRG0_PRU1_GPO14 | 9 |
| GPMC0_A10 | PRG1_PRU1_GPO7 | 8 | PRG0_PRU1_GPO15 | 9 |
| GPMC0_A11 | PRG1_PRU1_GPO8 | 8 | PRG0_PRU1_GPO16 | 9 |
| GPMC0_A12 | PRG1_PRU1_GPO9 | 8 | PRG0_MDIO0_MDIO | 9 |
| GPMC0_A13 | PRG1_PRU1_GPO10 | 8 | PRG0_MDIO0_MDC | 9 |
| GPMC0_A14 | PRG1_PRU1_GPO11 | 8 | PRG0_PRU0_GPO12 | 9 |
| GPMC0_A15 | PRG1_PRU1_GPO12 | 8 | PRG0_PRU0_GPO13 | 9 |
| GPMC0_A16 | PRG1_PRU1_GPO13 | 8 | PRG0_PRU0_GPO15 | 9 |
| GPMC0_A17 | PRG1_PRU1_GPO14 | 8 | PRG0_PRU0_GPO17 | 9 |
| GPMC0_A18 | PRG1_PRU1_GPO15 | 8 | PRG0_PRU1_GPO3 | 9 |
| GPMC0_A19 | PRG1_PRU1_GPO16 | 8 | PRG0_PRU1_GPO6 | 9 |
| GPMC0_BE3n | PRG1_PRU1_GPO17 | 8 | PRG1_PRU1_GPO17 | 8 |
| GPMC0_A20 | GPMC0_CSn3 | 4 | GPMC0_CSn3 | 4 |
| GPMC0_A21 | GPMC0_WAIT1 | 4 | GPMC0_WAIT1 | 4 |
| GPMC0_A22 | GPMC0_WPn | 4 | GPMC0_WPn | 4 |

6.11.5.9 I2C

The device contains six multicontroller Inter-Integrated Circuit (I2C) controllers. Each I2C controller was designed to be compliant to the Philips I²C-bus™ specification version 2.1. However, the device IOs are not fully compliant to the I2C electrical specification. The speeds supported and exceptions are described per port below:

- MCU_I2C1, I2C1, I2C2, and I2C3
 - Speeds:
 - Standard-mode (up to 100Kbits/s)
 - 1.8V
 - 3.3V
 - Fast-mode (up to 400Kbits/s)
 - 1.8V
 - 3.3V
 - Exceptions:
 - The IOs associated with these ports are not compliant to the fall time requirements defined in the I2C specification because they are implemented with higher performance LVCMOS push-pull IOs that were designed to support other signal functions that could not be implemented with I2C compatible IOs. The LVCMOS IOs being used on these ports are connected such they emulate open-drain outputs. This emulation is achieved by forcing a constant low output and disabling the output buffer to enter the Hi-Z state.
 - The I2C specification defines a maximum input voltage V_{IH} of $(V_{DD_{max}} + 0.5V)$, which exceeds the absolute maximum ratings for the device IOs. The system must be designed to ensure the I2C signals never exceed the limits defined in the *Absolute Maximum Ratings* section of this datasheet.
- MCU_I2C0 and I2C0
 - Speeds:
 - Standard-mode (up to 100Kbits/s)
 - 1.8V
 - 3.3V
 - Fast-mode (up to 400Kbits/s)
 - 1.8V
 - 3.3V
 - Hs-mode (up to 3.4Mbit/s)
 - 1.8V
 - Exceptions:
 - The IOs associated with these ports were not design to support Hs-mode while operating at 3.3V. So Hs-mode is limited to 1.8V operation.
 - The rise and fall times of the I2C signals connected to these ports must not exceed a slew rate of 0.08V/ns (or 8E+7V/s) when operating at 3.3V. This limit is more restrictive than the minimum fall time limits defined in the I2C specification. Therefore, it may be necessary to add additional capacitance to the I2C signals to slow the rise and fall times such that they do not exceed a slew rate of 0.08V/ns.
 - The I2C specification defines a maximum input voltage V_{IH} of $(V_{DD_{max}} + 0.5V)$, which exceeds the absolute maximum ratings for the device IOs. The system must be designed to ensure the I2C signals never exceed the limits defined in the *Absolute Maximum Ratings* section of this datasheet.

Note

I2C2 has one or more signals which can be multiplexed to more than one pin. Timing is only valid for specific pin combinations known as IOSETs. Valid pin combinations or IOSETs for this interface are defined in the [SysConfig-PinMux Tool](#).

Refer to the Philips I2C-bus specification version 2.1 for timing details.

For more details about features and additional description information on the device Inter-Integrated Circuit, see the corresponding subsections within *Signal Descriptions* and *Detailed Description* sections.

6.11.5.10 MCAN

Table 6-65 and Table 6-66 presents timing conditions and switching characteristics for MCAN.

For more details about features and additional description information on the device Controller Area Network Interface, see the corresponding subsections within *Signal Descriptions* and *Detailed Description* sections.

Note

The device has multiple MCAN modules. MCANn is a generic prefix applied to MCAN signal names, where n represents the specific MCAN module.

Table 6-65. MCAN Timing Conditions

| PARAMETER | | MIN | MAX | UNIT |
|--------------------------|-------------------------|-----|-----|------|
| INPUT CONDITIONS | | | | |
| SR _i | Input slew rate | 2 | 15 | V/ns |
| OUTPUT CONDITIONS | | | | |
| C _L | Output load capacitance | 5 | 20 | pF |

Table 6-66. MCAN Switching Characteristics

| NO. | PARAMETER | DESCRIPTION | MIN | MAX | UNIT |
|-------|-------------------------|---|-----|-----|------|
| MCAN1 | t _{d(MCAN_TX)} | Delay time, transmit shift register to MCANn_TX | | 10 | ns |
| MCAN2 | t _{d(MCAN_RX)} | Delay time, MCANn_RX to receive shift register | | 10 | ns |

For more information, see *Controller Area Network (MCAN)* section in *Peripherals* chapter in the device TRM.

6.11.5.11 MCSPI

For more details about features and additional description information on the device Serial Port Interface, see the corresponding subsections within *Signal Descriptions* and *Detailed Description* sections.

[Table 6-67](#) presents timing conditions for MCSPI.

Table 6-67. MCSPI Timing Conditions

| PARAMETER | | MIN | MAX | UNIT |
|--------------------------|-------------------------|-----|-----|------|
| INPUT CONDITIONS | | | | |
| SR _i | Input slew rate | 2 | 8.5 | V/ns |
| OUTPUT CONDITIONS | | | | |
| C _L | Output load capacitance | 6 | 12 | pF |

For more information, see *Multichannel Serial Peripheral Interface (MCSPI)* section in *Peripherals* chapter in the device TRM.

6.11.5.11.1 MCSPI — Controller Mode

Table 6-68, Figure 6-54, Table 6-69, and Figure 6-55 present timing requirements and switching characteristics for SPI – Controller Mode.

Table 6-68. MCSPI Timing Requirements – Controller Mode

see Figure 6-54

| NO. | PARAMETER | DESCRIPTION | MIN | MAX | UNIT |
|-----|-----------------------|---|-----|-----|------|
| SM4 | $t_{su}(POCI-SPICLK)$ | Setup time, SPIn_D[x] valid before SPIn_CLK active edge | 2.8 | | ns |
| SM5 | $t_h(SPICLK-POCI)$ | Hold time, SPIn_D[x] valid after SPIn_CLK active edge | 3 | | ns |

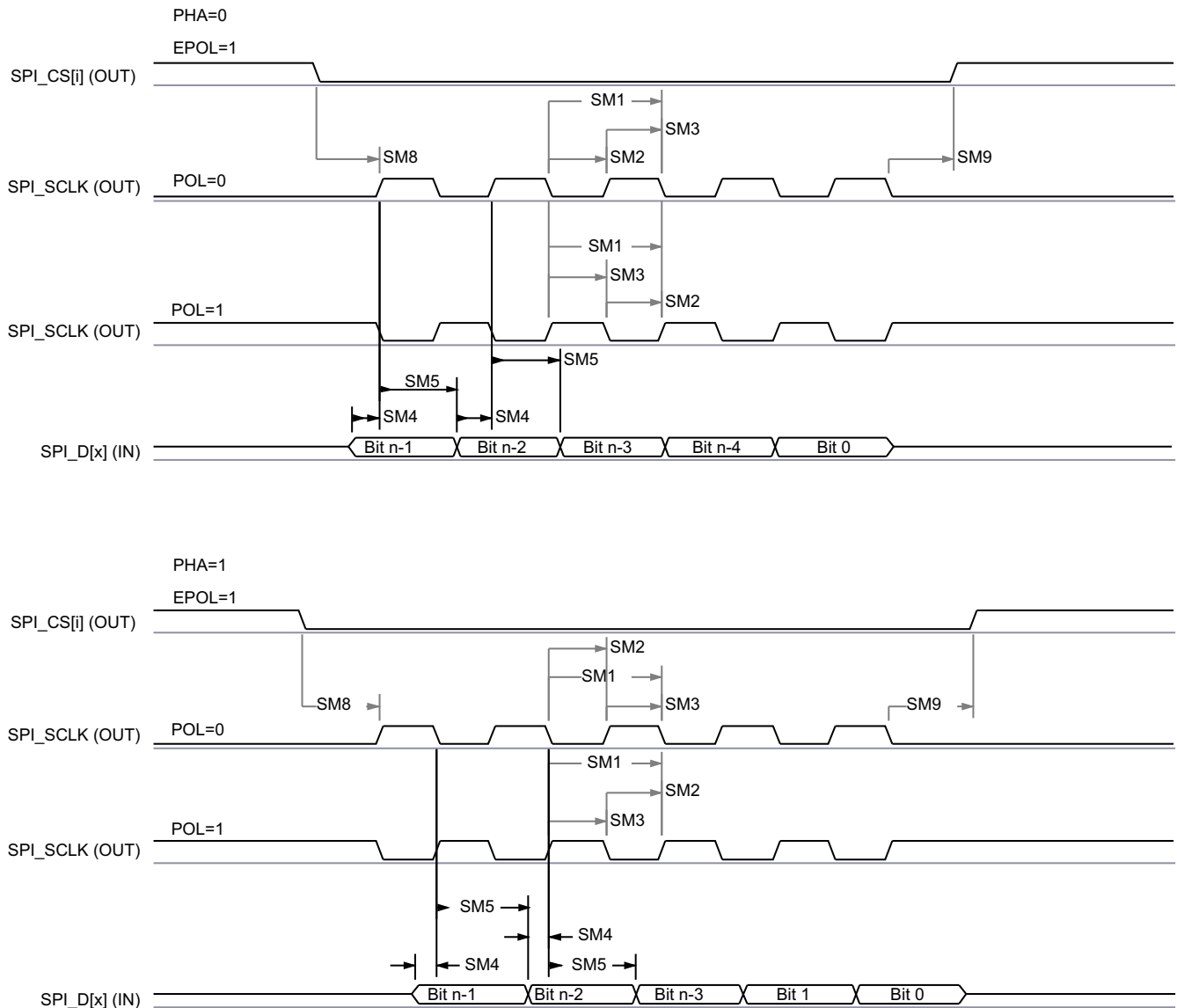

SPRSP08_TIMING_McSPI_02

Figure 6-54. MCSPI Controller Mode Receive Timing

Table 6-69. MCSPI Switching Characteristics - Controller Mode

 see [Figure 6-55](#)

| NO. | PARAMETER | | MIN | MAX | UNIT |
|-----|----------------------|---|------------------|----------------------|------|
| SM1 | $t_{c(SPICLK)}$ | Cycle time, SPIn_CLK | 20 | | ns |
| SM2 | $t_{w(SPICLKL)}$ | Pulse duration, SPIn_CLK low | $0.5P - 1^{(1)}$ | | ns |
| SM3 | $t_{w(SPICLKH)}$ | Pulse duration, SPIn_CLK high | $0.5P - 1^{(1)}$ | | ns |
| SM6 | $t_{d(SPICLK-PICO)}$ | Delay time, SPIn_CLK active edge to SPIn_D[x] | -3 | 2.5 | ns |
| SM7 | $t_{d(CS-PICO)}$ | Delay time, SPIn_CSi active edge to SPIn_D[x] | 5 | | ns |
| SM8 | $t_{d(CS-SPICLK)}$ | Delay time, SPIn_CSi active to SPIn_CLK first edge | PHA = 0 | B - 4 ⁽²⁾ | ns |
| | | | PHA = 1 | A - 4 ⁽³⁾ | ns |
| SM9 | $t_{d(SPICLK-CS)}$ | Delay time, SPIn_CLK last edge to SPIn_CSi inactive | PHA = 0 | A - 4 ⁽⁴⁾ | ns |
| | | | PHA = 1 | B - 4 ⁽⁵⁾ | ns |

- (1) P = SPIn_CLK period in ns.
- (2) T_{ref} is the period of the McSPI functional clock in ns. Fratio is the divide ratio of McSPI functional clock frequency to SPIn_CLK clock frequency, controlled by the CLKD and CLKG bit fields in the MCSPI_CH(i)CONF register and the EXTCLK bit field in the MCSPI_CH(i)CTRL register. TCS(i) is the value programmed into the chip select time control bit field of the MCSPI_CH(i)CONF register.
 - When Fratio = 1; B = (TCS(i) + 0.5) * T_{ref}.
 - When Fratio ≥ 2 and even value; B = (TCS(i) + 0.5) * Fratio * T_{ref}.
 - When Fratio ≥ 3 and odd value; B = ((TCS(i) * Fratio) + ((Fratio + 1) / 2)) * T_{ref}.
- (3) T_{ref} is the period of the McSPI functional clock. Fratio is the divide ratio of McSPI functional clock frequency to SPIn_CLK clock frequency, controlled by the CLKD and CLKG bit fields in the MCSPI_CH(i)CONF register and the EXTCLK bit field in the MCSPI_CH(i)CTRL register. TCS(i) is the value programmed into the chip select time control bit field of the MCSPI_CH(i)CONF register.
 - When Fratio = 1; A = (TCS(i) + 1) * T_{ref}.
 - When Fratio ≥ 2 and even value; A = (TCS(i) + 0.5) * Fratio * T_{ref}.
 - When Fratio ≥ 3 and odd value; A = ((TCS(i) * Fratio) + ((Fratio - 1) / 2)) * T_{ref}.
- (4) T_{ref} is the period of the McSPI functional clock. Fratio is the divide ratio of McSPI functional clock frequency to SPIn_CLK clock frequency, controlled by the CLKD and CLKG bit fields in the MCSPI_CH(i)CONF register and the EXTCLK bit field in the MCSPI_CH(i)CTRL register. TCS(i) is the value programmed into the chip select time control bit field of the MCSPI_CH(i)CONF register.
 - When Fratio = 1; A = (TCS(i) + 1) * T_{ref}.
 - When Fratio ≥ 2 and even value; A = (TCS(i) + 0.5) * Fratio * T_{ref}.
 - When Fratio ≥ 3 and odd value; A = ((TCS(i) * Fratio) + ((Fratio + 1) / 2)) * T_{ref}.
- (5) T_{ref} is the period of the McSPI functional clock. Fratio is the divide ratio of McSPI functional clock frequency to SPIn_CLK clock frequency, controlled by the CLKD and CLKG bit fields in the MCSPI_CH(i)CONF register and the EXTCLK bit field in the MCSPI_CH(i)CTRL register. TCS(i) is the value programmed into the chip select time control bit field of the MCSPI_CH(i)CONF register.
 - When Fratio = 1; B = (TCS(i) + 0.5) * T_{ref}.
 - When Fratio ≥ 2 and even value; B = (TCS(i) + 0.5) * Fratio * T_{ref}.
 - When Fratio ≥ 3 and odd value; B = ((TCS(i) * Fratio) + ((Fratio - 1) / 2)) * T_{ref}.

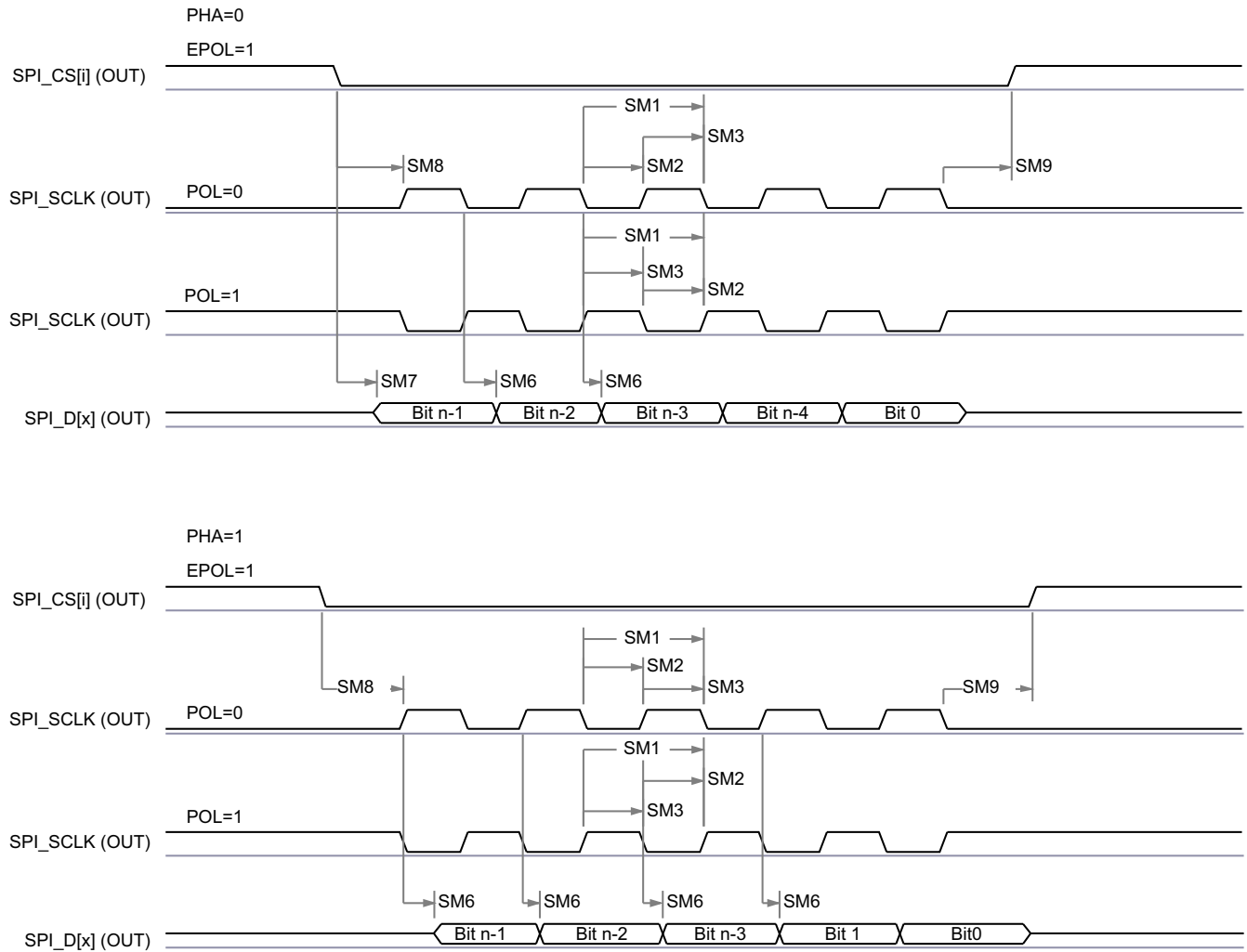

SPRSP08_TIMING_McSPI_01

Figure 6-55. MCSPI Controller Mode Transmit Timing

6.11.5.11.2 MCSPI — Peripheral Mode

Table 6-70, Figure 6-56, Table 6-71, and Figure 6-57 present timing requirements and switching characteristics for SPI – Peripheral Mode.

Table 6-70. MCSPI Timing Requirements – Peripheral Mode

see Figure 6-56

| NO. | PARAMETER | DESCRIPTION | MIN | MAX | UNIT |
|-----|-----------------------|---|----------------------|-----|------|
| SS1 | $t_{c(SPICLK)}$ | Cycle time, SPIn_CLK | 20 | | ns |
| SS2 | $t_{w(SPICLKL)}$ | Pulse duration, SPIn_CLK low | 0.45P ⁽¹⁾ | | ns |
| SS3 | $t_{w(SPICLKH)}$ | Pulse duration, SPIn_CLK high | 0.45P ⁽¹⁾ | | ns |
| SS4 | $t_{su(PICO-SPICLK)}$ | Setup time, SPIn_D[x] valid before SPIn_CLK active edge | 5 | | ns |
| SS5 | $t_{h(SPICLK-PICO)}$ | Hold time, SPIn_D[x] valid after SPIn_CLK active edge | 5 | | ns |
| SS8 | $t_{su(CS-SPICLK)}$ | Setup time, SPIn_CSi valid before SPIn_CLK first edge | 5 | | ns |
| SS9 | $t_{h(SPICLK-CS)}$ | Hold time, SPIn_CSi valid after SPIn_CLK last edge | 5 | | ns |

(1) P = SPIn_CLK period in ns.

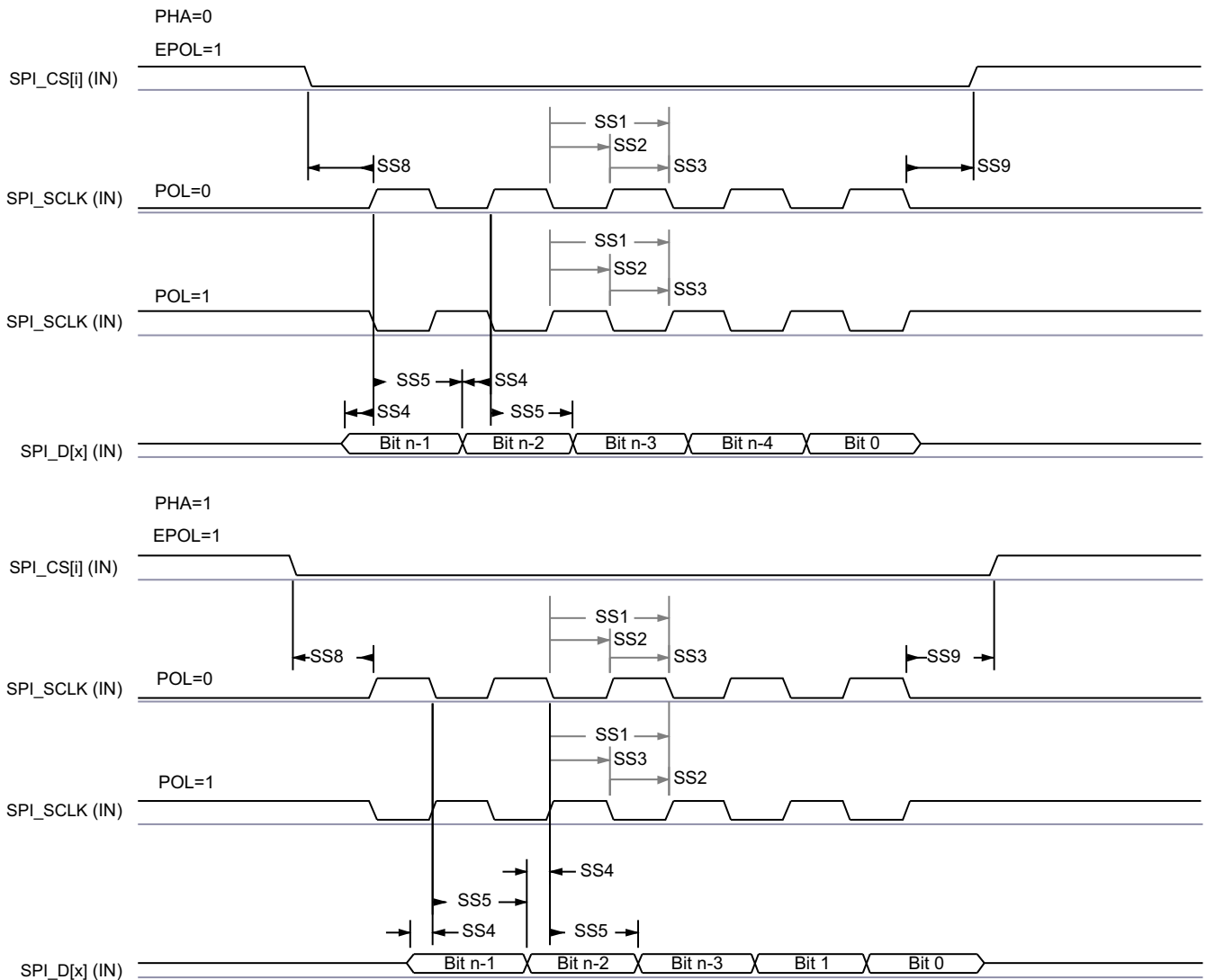

SPRSP08_TIMING_McSPI_04

Figure 6-56. SPI Peripheral Mode Receive Timing

Table 6-71. MCSPI Switching Characteristics – Peripheral Mode

see [Figure 6-57](#)

| NO. | PARAMETER | DESCRIPTION | MIN | MAX | UNIT |
|-----|----------------------|---|-----|------|------|
| SS6 | $t_{d(SPICLK-POCI)}$ | Delay time, SPIn_CLK active edge to SPIn_D[x] | 2 | 10.5 | ns |
| SS7 | $t_{sk(CS-POCI)}$ | Delay time, SPIn_CSi active edge to SPIn_D[x] | | 18.5 | ns |

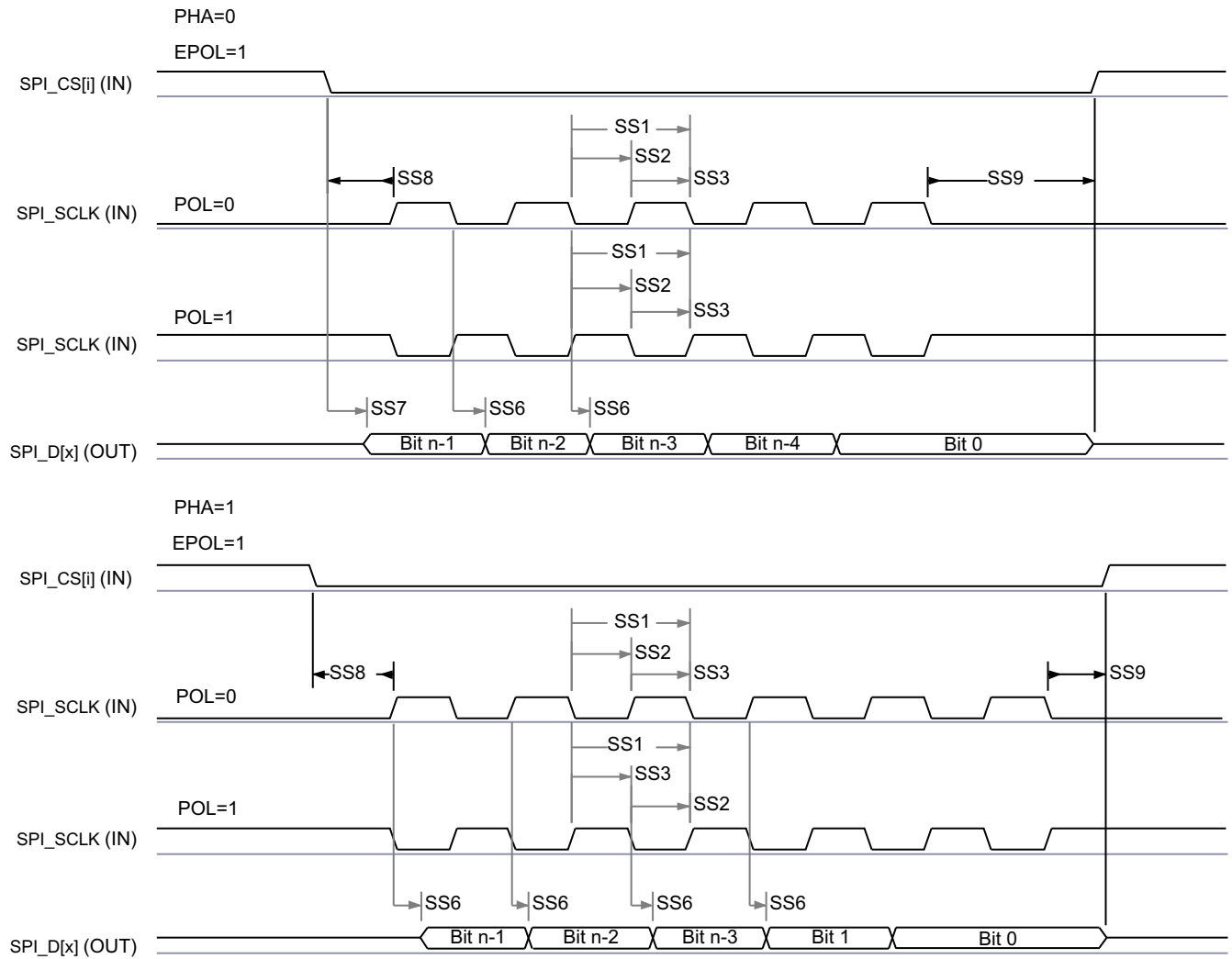

SPRSP08_TIMING_McSPI_03

Figure 6-57. SPI Peripheral Mode Transmit Timing

6.11.5.12 MMCS D

The MMCS D Host Controller provides an interface to embedded Multi-Media Card (MMC), Secure Digital (SD), and Secure Digital IO (SDIO) devices. The MMCS D Host Controller deals with MMC/SD/SDIO protocol at transmission level, data packing, adding cyclic redundancy checks (CRCs), start/end bit insertion, and checking for syntactical correctness.

For more details about MMCS D interfaces, see the corresponding MMC0 and MMC1 subsections within *Signal Descriptions* and *Detailed Description* sections.

Note

Some operating modes require software configuration of the MMC DLL delay settings, as shown in [Table 6-72](#) and [Table 6-82](#).

The modes which show a value of "Tuning" in the ITAPDLYSEL column of [Table 6-72](#) and [Table 6-82](#) require a tuning algorithm to be used for optimizing input timing. Refer to the MMCS D Programming Guide in the device TRM for more information on the tuning algorithm and configuration of input delays required to optimize input timing.

For more information, see *Multi-Media Card/Secure Digital (MMCS D) Interface* section in *Peripherals* chapter in the device TRM.

6.11.5.12.1 MMC0 - eMMC Interface

MMC0 interface is compliant with the JEDEC eMMC electrical standard v5.1 (JESD84-B51) and supports the following eMMC applications:

- Legacy speed
- High speed SDR
- High speed DDR
- HS200

[Table 6-72](#) presents the required DLL software configuration settings for MMC0 timing modes.

Table 6-72. MMC0 DLL Delay Mapping for all Timing Modes

| REGISTER NAME | | MMCS D0_MMC_SSCFG_PHY_CTRL_x_REG | | | | | | | | |
|----------------------|--|----------------------------------|-----------------|---------------------------|--------------------------|--------------------------|-------------------------|---------------------------------|----------------------|-----------------------------|
| | | x = 1 | | x = 4 | | | | x = 5 | | |
| BIT FIELD | | [1] | [31:24] | [20] | [15:12] | [8] | [4:0] | [17:16] | [10:8] | [2:0] |
| BIT FIELD NAME | | ENDLL | STRBSEL | OTAPDLYENA | OTAPDLYSEL | ITAPDLYENA | ITAPDLYSEL | SELDLYTXCLK SELDLYRXCLK | FRQSEL | CLKBUFSEL |
| MODE | DESCRIPTION | ENABLE DLL | STROBE DELAY | OUTPUT DELAY ENABLE | OUTPUT DELAY VALUE | INPUT DELAY ENABLE | INPUT DELAY VALUE | DLL DELAY CHAIN SELECT | DLL REF FREQUENCY | DELAY BUFFER DURATION |
| Legacy SDR | 8-bit PHY operating 1.8V, 25MHz | 0x0 | 0x0 | NA ⁽¹⁾ | NA ⁽¹⁾ | 0x1 | 0x10 | 0x1 or 0x3 ⁽²⁾ | NA ⁽³⁾ | 0x7 |
| High Speed SDR | 8-bit PHY operating 1.8V, 50MHz | 0x0 | 0x0 | NA ⁽¹⁾ | NA ⁽¹⁾ | 0x1 | 0xA | 0x1 or 0x3 ⁽²⁾ | NA ⁽³⁾ | 0x7 |
| High Speed DDR | 8-bit PHY operating 1.8V, 50MHz | 0x1 | 0x0 | 0x1 | 0x6 | 0x1 | 0x3 | 0x0 | 0x4 | NA ⁽⁴⁾ |
| HS200 | 8-bit PHY operating 1.8V, 200MHz | 0x1 | 0x0 | 0x1 | 0x7 | 0x1 | Tuning ⁽⁵⁾ | 0x0 | 0x0 | NA ⁽⁴⁾ |

(1) NA means this register field has no function when operating with half-cycle timing, which is required for this mode.

(2) The SELDLYTXCLK bit has no function when operating with half-cycle timing, which is required for this mode.

(3) NA means this register field has no function when ENDLL is set to 0x0.

(4) NA means this register field has no function when ENDLL is set to 0x1.

(5) Tuning means this mode requires a tuning algorithm to be used to determine optimal input timing

[Table 6-73](#) presents timing conditions for MMC0.

Table 6-73. MMC0 Timing Conditions

| PARAMETER | | | MIN | MAX | UNIT |
|---------------------------------------|--|----------------------------|------|------|------|
| INPUT CONDITIONS | | | | | |
| SR _i | Input slew rate | Legacy SDR | 0.14 | 1.44 | V/ns |
| | | High Speed SDR | 0.3 | 0.9 | V/ns |
| | | High Speed DDR (CMD) | 0.3 | 0.9 | V/ns |
| | | High Speed DDR (DAT[7:0]) | 0.45 | 0.9 | V/ns |
| OUTPUT CONDITIONS | | | | | |
| C _L | Output load capacitance | Legacy SDR | 1 | 12 | pF |
| | | High Speed SDR | 1 | 12 | pF |
| | | High Speed DDR | 1 | 12 | pF |
| | | HS200 | 1 | 6 | pF |
| PCB CONNECTIVITY REQUIREMENTS | | | | | |
| t _d (Trace Delay) | Propagation delay of each trace | All modes | 126 | 756 | ps |
| t _d (Trace Mismatch Delay) | Propagation delay mismatch across all traces | Legacy SDR, High Speed SDR | | 100 | ps |
| | | High Speed DDR, HS200 | | 8 | ps |

6.11.5.12.1.1 Legacy SDR Mode

Table 6-74, Figure 6-58, Table 6-75, and Figure 6-59 present timing requirements and switching characteristics for MMC0 – Legacy SDR Mode.

Table 6-74. MMC0 Timing Requirements – Legacy SDR Mode

see Figure 6-58

| NO. | | | MIN | MAX | UNIT |
|-------|---------------------|---|------|-----|------|
| LSDR1 | $t_{su}(cmdV-clkH)$ | Setup time, MMC0_CMD valid before MMC0_CLK rising edge | 1.56 | | ns |
| LSDR2 | $t_h(clkH-cmdV)$ | Hold time, MMC0_CMD valid after MMC0_CLK rising edge | 5.44 | | ns |
| LSDR3 | $t_{su}(dV-clkH)$ | Setup time, MMC0_DAT[7:0] valid before MMC0_CLK rising edge | 1.56 | | ns |
| LSDR4 | $t_h(clkH-dV)$ | Hold time, MMC0_DAT[7:0] valid after MMC0_CLK rising edge | 5.44 | | ns |

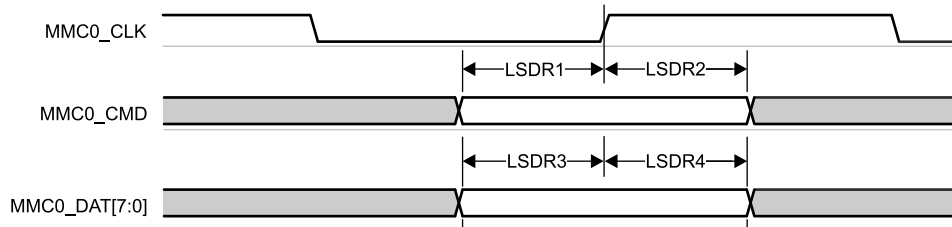

Figure 6-58. MMC0 – Legacy SDR – Receive Mode

Table 6-75. MMC0 Switching Characteristics – Legacy SDR Mode

see Figure 6-59

| NO. | PARAMETER | MIN | MAX | UNIT |
|-------|------------------|------|-----|------|
| | $f_{op}(clk)$ | | 25 | MHz |
| LSDR5 | $t_c(clk)$ | 40 | | ns |
| LSDR6 | $t_w(clkH)$ | 18.7 | | ns |
| LSDR7 | $t_w(clkL)$ | 18.7 | | ns |
| LSDR8 | $t_d(clkL-cmdV)$ | -2.3 | 2.9 | ns |
| LSDR9 | $t_d(clkL-dV)$ | -2.3 | 2.9 | ns |

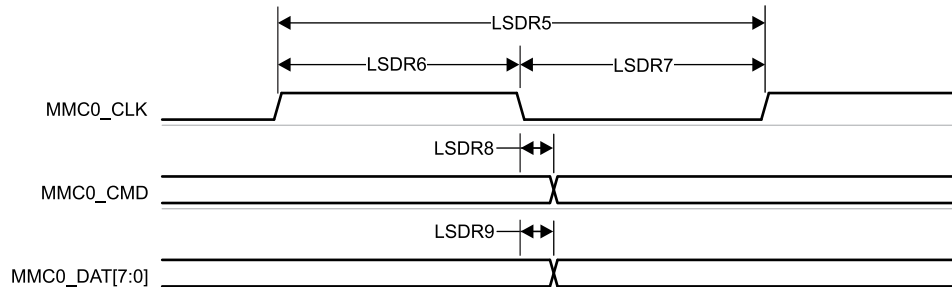

Figure 6-59. MMC0 – Legacy SDR – Transmit Mode

6.11.5.12.1.2 High Speed SDR Mode

Table 6-76, Figure 6-60, Table 6-77, and Figure 6-61 present timing requirements and switching characteristics for MMC0 – High Speed SDR Mode.

Table 6-76. MMC0 Timing Requirements – High Speed SDR Mode

see Figure 6-60

| NO. | | | MIN | MAX | UNIT |
|--------|---------------------|---|------|-----|------|
| HSSDR1 | $t_{su(cmdV-clkH)}$ | Setup time, MMC0_CMD valid before MMC0_CLK rising edge | 2.55 | | ns |
| HSSDR2 | $t_{h(clkH-cmdV)}$ | Hold time, MMC0_CMD valid after MMC0_CLK rising edge | 2.67 | | ns |
| HSSDR3 | $t_{su(dV-clkH)}$ | Setup time, MMC0_DAT[7:0] valid before MMC0_CLK rising edge | 2.55 | | ns |
| HSSDR4 | $t_{h(clkH-dV)}$ | Hold time, MMC0_DAT[7:0] valid after MMC0_CLK rising edge | 2.67 | | ns |

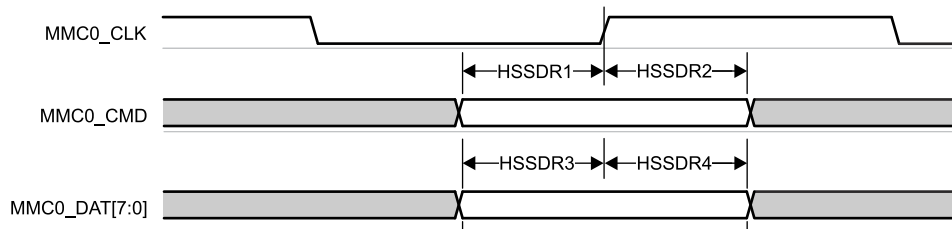

Figure 6-60. MMC0 – High Speed SDR Mode – Receive Mode

Table 6-77. MMC0 Switching Characteristics – High Speed SDR Mode

see Figure 6-61

| NO. | PARAMETER | MIN | MAX | UNIT |
|--------|------------------|------|-----|------|
| | $f_{op(clk)}$ | | 50 | MHz |
| HSSDR5 | $t_c(clk)$ | 20 | | ns |
| HSSDR6 | $t_w(clkH)$ | 9.2 | | ns |
| HSSDR7 | $t_w(clkL)$ | 9.2 | | ns |
| HSSDR8 | $t_d(clkL-cmdV)$ | -2.3 | 2.9 | ns |
| HSSDR9 | $t_d(clkL-dV)$ | -2.3 | 2.9 | ns |

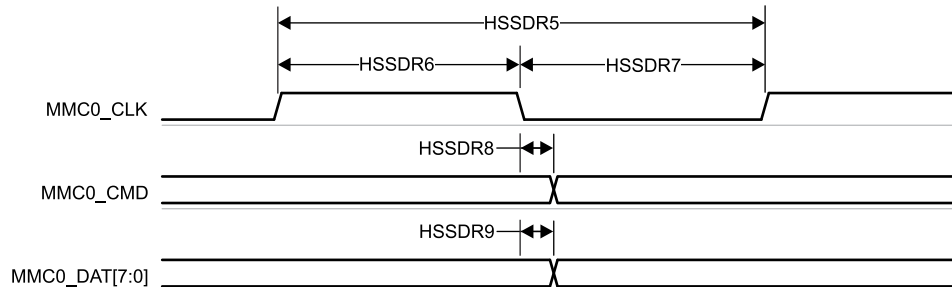

Figure 6-61. MMC0 – High Speed SDR Mode – Transmit Mode

6.11.5.12.1.3 High Speed DDR Mode

Table 6-78, Figure 6-62, Table 6-79, and Figure 6-63 present timing requirements and switching characteristics for MMC0 – High Speed DDR Mode.

Table 6-78. MMC0 Timing Requirements – High Speed DDR Mode

see Figure 6-62

| NO. | | | MIN | MAX | UNIT |
|--------|--------------------|--|------|-----|------|
| HSDDR1 | $t_{su(cmdV-clk)}$ | Setup time, MMC0_CMD valid before MMC0_CLK rising edge | 1.62 | | ns |
| HSDDR2 | $t_{h(clk-cmdV)}$ | Hold time, MMC0_CMD valid after MMC0_CLK rising edge | 2.52 | | ns |
| HSDDR3 | $t_{su(dV-clk)}$ | Setup time, MMC0_DAT[7:0] valid before MMC0_CLK transition | 0.83 | | ns |
| HSDDR4 | $t_{h(clk-dV)}$ | Hold time, MMC0_DAT[7:0] valid after MMC0_CLK transition | 1.76 | | ns |

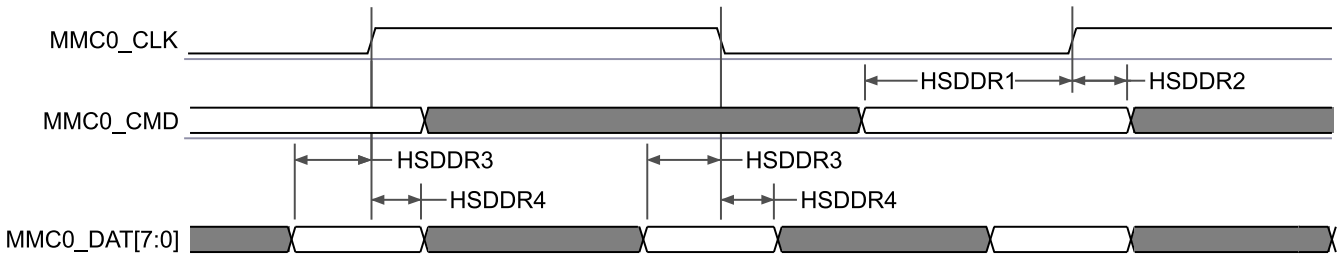

Figure 6-62. MMC0 – High Speed DDR Mode – Receive Mode

Table 6-79. MMC0 Switching Characteristics – High Speed DDR Mode

see Figure 6-63

| NO. | PARAMETER | MIN | MAX | UNIT |
|--------|-------------------|------|------|------|
| | $f_{op(clk)}$ | | 50 | MHz |
| HSDDR5 | $t_{c(clk)}$ | 20 | | ns |
| HSDDR6 | $t_{w(clkH)}$ | 9.2 | | ns |
| HSDDR7 | $t_{w(clkL)}$ | 9.2 | | ns |
| HSDDR8 | $t_{d(clk-cmdV)}$ | 3.31 | 7.65 | ns |
| HSDDR9 | $t_{d(clk-dV)}$ | 2.81 | 6.94 | ns |

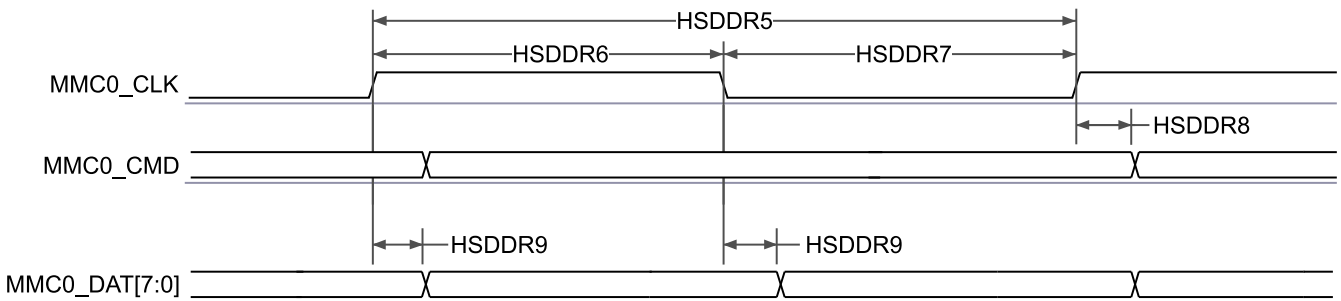

Figure 6-63. MMC0 – High Speed DDR Mode – Transmit Mode

6.11.5.12.1.4 HS200 Mode

Table 6-80, Figure 6-64, Table 6-81, and Figure 6-65 present switching characteristics for MMC0 – HS200 Mode.

Table 6-80. MMC0 Timing Requirements – HS200 Mode

see Figure 6-64

| NO. | | | MIN | MAX | UNIT |
|--------|-----------|---|--------------------|-----|------|
| HS2004 | t_{DvW} | Input data valid window, MMC0_CMD and MMC0_DAT[7:0] | 2.0 ⁽¹⁾ | | ns |

- (1) This parameter defines the minimum data valid window required by the host, where any data valid window presented to the host greater than this value ensures the host is able to capture valid data. The value defined by this parameter is smaller than the smallest possible data valid window defined for any eMMC device operating in HS200 mode.

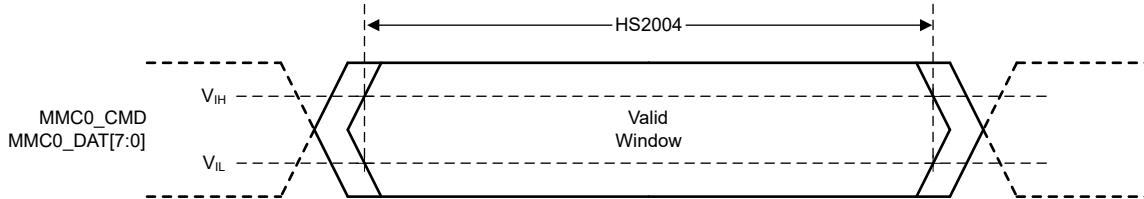

Figure 6-64. MMC0 – HS200 – Receive Mode

Table 6-81. MMC0 Switching Characteristics – HS200 Mode

see Figure 6-65

| NO. | PARAMETER | MIN | MAX | UNIT |
|--------|--------------------|------|------|------|
| | $f_{op(clk)}$ | | 200 | MHz |
| HS2005 | $t_{c(clk)}$ | | 5 | ns |
| HS2006 | $t_{w(clkH)}$ | 2.08 | | ns |
| HS2007 | $t_{w(clkL)}$ | 2.08 | | ns |
| HS2008 | $t_{d(clkL-cmdV)}$ | 0.99 | 3.28 | ns |
| HS2009 | $t_{d(clkL-dV)}$ | 0.99 | 3.28 | ns |

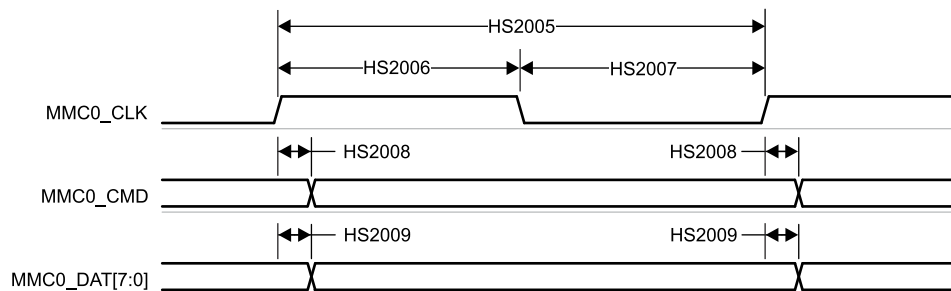

Figure 6-65. MMC0 – HS200 Mode – Transmit Mode

6.11.5.12.2 MMC1 - SD/SDIO Interface

MMC1 interface is compliant with the SD Host Controller Standard Specification 4.10 and SD Physical Layer Specification v3.01 as well as SDIO Specification v3.00 and it supports the following SD Card applications:

- Default speed
- High speed
- UHS-I SDR12
- UHS-I SDR25
- UHS-I SDR50
- UHS-I SDR104
- UHS-I DDR50

Table 6-82 presents the required DLL software configuration settings for MMC1 timing modes.

Table 6-82. MMC1 DLL Delay Mapping for all Timing Modes

| REGISTER NAME | | MMCS11_MMC_SSCFG_PHY_CTRL_4_REG | | | |
|----------------|----------------------------------|---------------------------------|-------------------|--------------------|-----------------------|
| BIT FIELD | | [20] | [15:12] | [8] | [4:0] |
| BIT FIELD NAME | | OTAPDLYENA | OTAPDLYSEL | ITAPDLYENA | ITAPDLYSEL |
| MODE | DESCRIPTION | DELAY ENABLE | DELAY VALUE | INPUT DELAY ENABLE | INPUT DELAY VALUE |
| Default Speed | 4-bit PHY operating 3.3V, 25MHz | NA ⁽¹⁾ | NA ⁽¹⁾ | 0x1 | 0x0 |
| High Speed | 4-bit PHY operating 3.3V, 50MHz | NA ⁽¹⁾ | NA ⁽¹⁾ | 0x1 | 0x0 |
| UHS-I SDR12 | 4-bit PHY operating 1.8V, 25MHz | 0x1 | 0xF | 0x1 | 0x0 |
| UHS-I SDR25 | 4-bit PHY operating 1.8V, 50MHz | 0x1 | 0xF | 0x1 | 0x0 |
| UHS-I SDR50 | 4-bit PHY operating 1.8V, 100MHz | 0x1 | 0xC | 0x1 | Tuning ⁽²⁾ |
| UHS-I DDR50 | 4-bit PHY operating 1.8V, 50MHz | 0x1 | 0x9 | 0x1 | Tuning ⁽²⁾ |
| UHS-I SDR104 | 4-bit PHY operating 1.8V 200MHz | 0x1 | 0x6 | 0x1 | Tuning ⁽²⁾ |

(1) NA means this register field has no function when operating with half-cycle timing, which is required for this mode.

(2) Tuning means this mode requires a tuning algorithm to be used to determine optimal input timing

Table 6-83 presents timing conditions for MMC1.

Table 6-83. MMC1 Timing Conditions

| PARAMETER | | | MIN | MAX | UNIT |
|---------------------------------------|--|---------------------------|------|------|------|
| Input Conditions | | | | | |
| SR _i | Input slew rate | Default Speed, High Speed | 0.69 | 2.06 | V/ns |
| | | UHS-I SDR12, UHS-I SDR25 | 0.34 | 1.34 | V/ns |
| | | UHS-I DDR50 | 1 | 2 | V/ns |
| Output Conditions | | | | | |
| C _L | Output load capacitance | UHS-I DDR50 | 3 | 10 | pF |
| | | All other modes | 1 | 10 | pF |
| PCB Connectivity Requirements | | | | | |
| t _d (Trace Delay) | Propagation delay of each trace | UHS-I DDR50 | 240 | 1134 | ps |
| | | All other modes | 126 | 1386 | ps |
| t _d (Trace Mismatch Delay) | Propagation delay mismatch across all traces | UHS-I DDR50, UHS-I SDR104 | | 20 | ps |
| | | All other modes | | 100 | ps |

6.11.5.12.2.1 Default Speed Mode

Table 6-84, Figure 6-66, Table 6-85, and Figure 6-67 present timing requirements and switching characteristics for MMC1 – Default Speed Mode.

Table 6-84. Timing Requirements for MMC1 – Default Speed Mode

see Figure 6-66

| NO. | | | MIN | MAX | UNIT |
|-----|---------------------|---|------|-----|------|
| DS1 | $t_{su(cmdV-clkH)}$ | Setup time, MMC1_CMD valid before MMCi_CLK rising edge | 2.15 | | ns |
| DS2 | $t_{h(clkH-cmdV)}$ | Hold time, MMC1_CMD valid after MMC1_CLK rising edge | 1.67 | | ns |
| DS3 | $t_{su(dV-clkH)}$ | Setup time, MMC1_DAT[3:0] valid before MMC1_CLK rising edge | 2.15 | | ns |
| DS4 | $t_{h(clkH-dV)}$ | Hold time, MMC1_DAT[3:0] valid after MMC1_CLK rising edge | 1.67 | | ns |

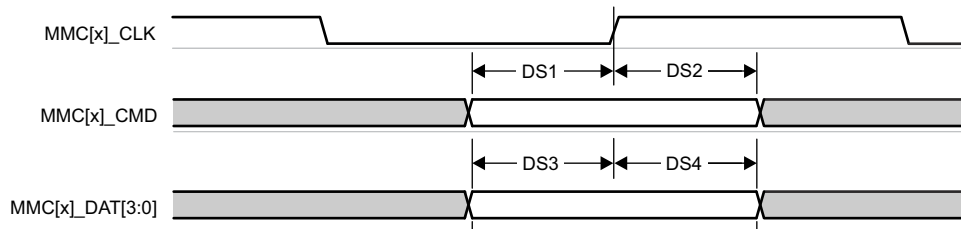

Figure 6-66. MMC1 – Default Speed – Receive Mode

Table 6-85. Switching Characteristics for MMC1 – Default Speed Mode

see Figure 6-67

| NO. | PARAMETER | MIN | MAX | UNIT |
|-----|--------------------|------|-----|------|
| | $f_{op(clk)}$ | | 25 | MHz |
| DS5 | $t_{c(clk)}$ | 40 | | ns |
| DS6 | $t_{w(clkH)}$ | 18.7 | | ns |
| DS7 | $t_{w(clkL)}$ | 18.7 | | ns |
| DS8 | $t_{d(clkL-cmdV)}$ | -1.8 | 1.8 | ns |
| DS9 | $t_{d(clkL-dV)}$ | -1.8 | 1.8 | ns |

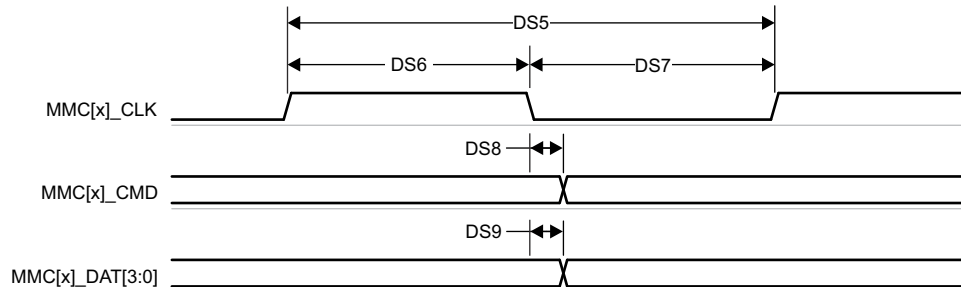

Figure 6-67. MMC1 – Default Speed – Transmit Mode

6.11.5.12.2.2 High Speed Mode

Table 6-86, Figure 6-68, Table 6-87, and Figure 6-69 present timing requirements and switching characteristics for MMC1 – High Speed Mode.

Table 6-86. Timing Requirements for MMC1 – High Speed Mode

see Figure 6-68

| NO. | | | MIN | MAX | UNIT |
|-----|---------------------|---|------|-----|------|
| HS1 | $t_{su(cmdV-clkH)}$ | Setup time, MMC1_CMD valid before MMC1_CLK rising edge | 2.15 | | ns |
| HS2 | $t_h(clkH-cmdV)$ | Hold time, MMC1_CMD valid after MMC1_CLK rising edge | 1.67 | | ns |
| HS3 | $t_{su(dV-clkH)}$ | Setup time, MMC1_DAT[3:0] valid before MMC1_CLK rising edge | 2.15 | | ns |
| HS4 | $t_h(clkH-dV)$ | Hold time, MMC1_DAT[3:0] valid after MMC1_CLK rising edge | 1.67 | | ns |

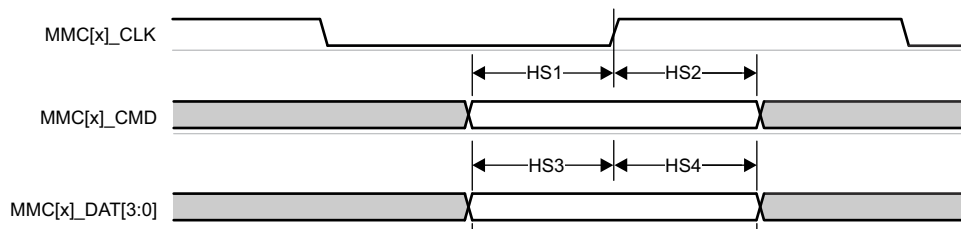

Figure 6-68. MMC1 – High Speed – Receive Mode

Table 6-87. Switching Characteristics for MMC1 – High Speed Mode

see Figure 6-69

| NO. | PARAMETER | MIN | MAX | UNIT |
|-----|------------------|------|-----|------|
| | $f_{op(clk)}$ | | 50 | MHz |
| HS5 | $t_c(clk)$ | 20 | | ns |
| HS6 | $t_w(clkH)$ | 9.2 | | ns |
| HS7 | $t_w(clkL)$ | 9.2 | | ns |
| HS8 | $t_d(clkL-cmdV)$ | -1.8 | 1.8 | ns |
| HS9 | $t_d(clkL-dV)$ | -1.8 | 1.8 | ns |

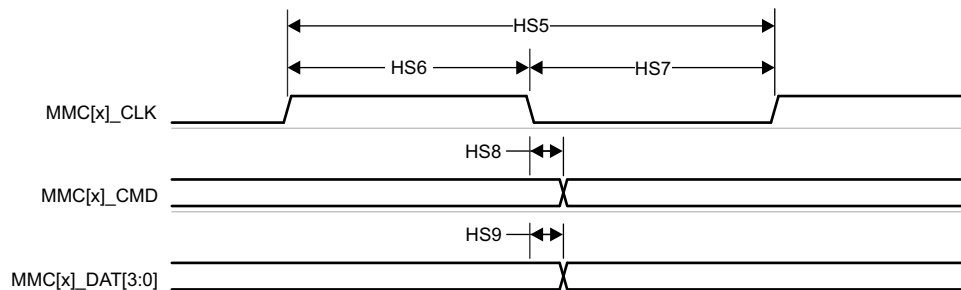

Figure 6-69. MMC1 – High Speed – Transmit Mode

6.11.5.12.2.3 UHS-I SDR12 Mode

Table 6-88, Figure 6-70, Table 6-89, and Figure 6-71 present timing requirements and switching characteristics for MMC1 – UHS-I SDR12 Mode.

Table 6-88. Timing Requirements for MMC1 – UHS-I SDR12 Mode

see Figure 6-70

| NO. | | | MIN | MAX | UNIT |
|--------|---------------------|---|------|-----|------|
| SDR121 | $t_{su(cmdV-clkH)}$ | Setup time, MMC1_CMD valid before MMC1_CLK rising edge | 2.35 | | ns |
| SDR122 | $t_{h(clkH-cmdV)}$ | Hold time, MMC1_CMD valid after MMC1_CLK rising edge | 1.67 | | ns |
| SDR123 | $t_{su(dV-clkH)}$ | Setup time, MMC1_DAT[3:0] valid before MMC1_CLK rising edge | 2.35 | | ns |
| SDR124 | $t_{h(clkH-dV)}$ | Hold time, MMC1_DAT[3:0] valid after MMC1_CLK rising edge | 1.67 | | ns |

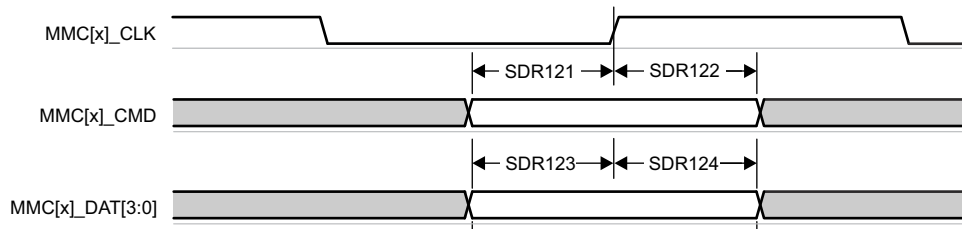

Figure 6-70. MMC1 – UHS-I SDR12 – Receive Mode

Table 6-89. Switching Characteristics for MMC1 – UHS-I SDR12 Mode

see Figure 6-71

| NO. | PARAMETER | MIN | MAX | UNIT |
|--------|--------------------|------|-----|------|
| | $f_{op(clk)}$ | | 25 | MHz |
| SDR125 | $t_{c(clk)}$ | 40 | | ns |
| SDR126 | $t_{w(clkH)}$ | 18.7 | | ns |
| SDR127 | $t_{w(clkL)}$ | 18.7 | | ns |
| SDR128 | $t_{d(clkL-cmdV)}$ | 1.2 | 8 | ns |
| SDR129 | $t_{d(clkL-dV)}$ | 1.2 | 8 | ns |

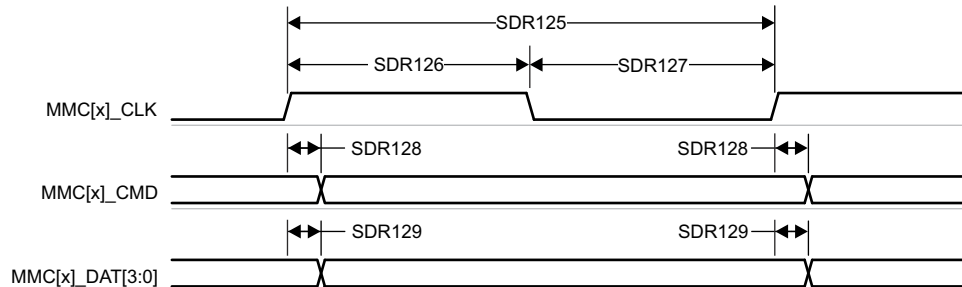

Figure 6-71. MMC1 – UHS-I SDR12 – Transmit Mode

6.11.5.12.2.4 UHS-I SDR25 Mode

Table 6-90, Figure 6-72, Table 6-91, and Figure 6-73 present timing requirements and switching characteristics for MMC1 – UHS-I SDR25 Mode.

Table 6-90. Timing Requirements for MMC1 – UHS-I SDR25 Mode

see Figure 6-72

| NO. | | | MIN | MAX | UNIT |
|--------|---------------------|---|------|-----|------|
| SDR251 | $t_{su(cmdV-clkH)}$ | Setup time, MMC1_CMD valid before MMC1_CLK rising edge | 1.95 | | ns |
| SDR252 | $t_{h(clkH-cmdV)}$ | Hold time, MMC1_CMD valid after MMC1_CLK rising edge | 1.67 | | ns |
| SDR253 | $t_{su(dV-clkH)}$ | Setup time, MMC1_DAT[3:0] valid before MMC1_CLK rising edge | 1.95 | | ns |
| SDR254 | $t_{h(clkH-dV)}$ | Hold time, MMC1_DAT[3:0] valid after MMC1_CLK rising edge | 1.67 | | ns |

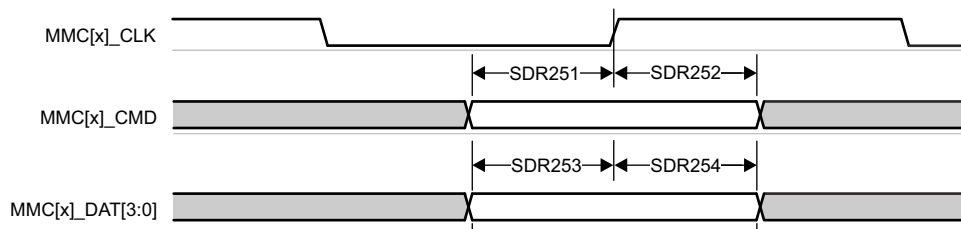

Figure 6-72. MMC1 – UHS-I SDR25 – Receive Mode

Table 6-91. Switching Characteristics for MMC1 – UHS-I SDR25 Mode

see Figure 6-73

| NO. | PARAMETER | MIN | MAX | UNIT |
|--------|--------------------|-----|-----|------|
| | $f_{op(clk)}$ | | 50 | MHz |
| SDR255 | $t_{c(clk)}$ | 20 | | ns |
| SDR256 | $t_{w(clkH)}$ | 9.2 | | ns |
| SDR257 | $t_{w(clkL)}$ | 9.2 | | ns |
| SDR258 | $t_{d(clkL-cmdV)}$ | 2.4 | 8 | ns |
| SDR259 | $t_{d(clkL-dV)}$ | 2.4 | 8 | ns |

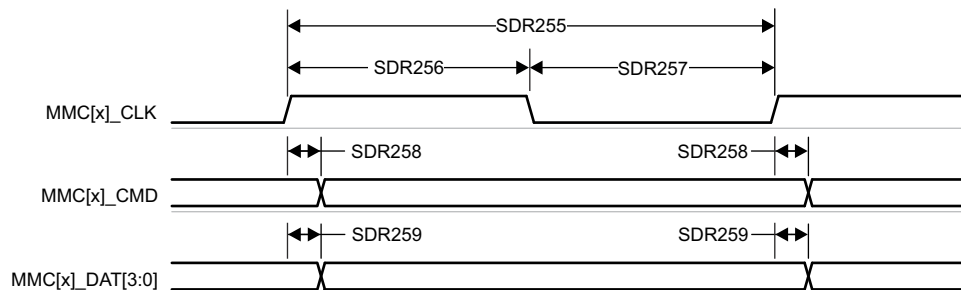

Figure 6-73. MMC1 – UHS-I SDR25 – Transmit Mode

6.11.5.12.2.5 UHS-I SDR50 Mode

Table 6-92, and Figure 6-74 presents switching characteristics for MMC1 – UHS-I SDR50 Mode.

Table 6-92. Switching Characteristics for MMC1 – UHS-I SDR50 Mode

see Figure 6-74

| NO. | PARAMETER | | MIN | MAX | UNIT |
|--------|--------------------|--|------|------|------|
| | $f_{op}(clk)$ | Operating frequency, MMC1_CLK | | 100 | MHz |
| SDR505 | $t_{c}(clk)$ | Cycle time, MMC1_CLK | 10 | | ns |
| SDR506 | $t_{w}(clkH)$ | Pulse duration, MMC1_CLK high | 4.45 | | ns |
| SDR507 | $t_{w}(clkL)$ | Pulse duration, MMC1_CLK low | 4.45 | | ns |
| SDR508 | $t_{d}(clkL-cmdV)$ | Delay time, MMC1_CLK rising edge to MMC1_CMD transition | 1.2 | 6.35 | ns |
| SDR509 | $t_{d}(clkL-dV)$ | Delay time, MMC1_CLK rising edge to MMC1_DAT[3:0] transition | 1.2 | 6.35 | ns |

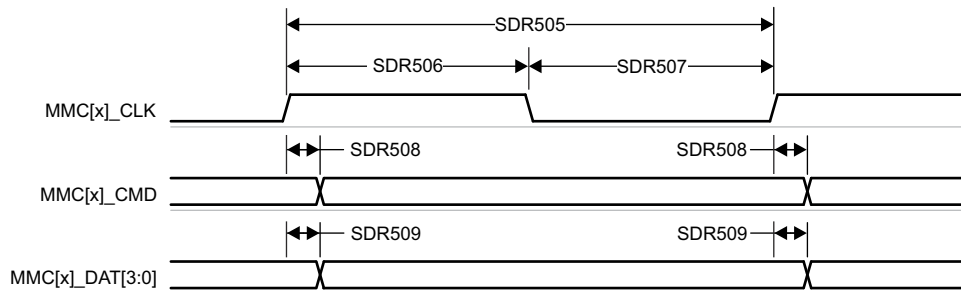

Figure 6-74. MMC1 – UHS-I SDR50 – Transmit Mode

6.11.5.12.2.6 UHS-I DDR50 Mode

Table 6-93, and Figure 6-75 present switching characteristics for MMC1 – UHS-I DDR50 Mode.

Table 6-93. Switching Characteristics for MMC1 – UHS-I DDR50 Mode

see Figure 6-75

| NO. | PARAMETER | | MIN | MAX | UNIT |
|--------|-------------------|---|-----|------|------|
| | $f_{op}(clk)$ | Operating frequency, MMC1_CLK | | 50 | MHz |
| DDR505 | $t_{c}(clk)$ | Cycle time, MMC1_CLK | 20 | | ns |
| DDR506 | $t_{w}(clkH)$ | Pulse duration, MMC1_CLK high | 9.2 | | ns |
| DDR507 | $t_{w}(clkL)$ | Pulse duration, MMC1_CLK low | 9.2 | | ns |
| DDR508 | $t_{d}(clk-cmdV)$ | Delay time, MMC1_CLK rising edge to MMC1_CMD transition | 1.2 | 6.35 | ns |
| DDR509 | $t_{d}(clk-dV)$ | Delay time, MMC1_CLK transition to MMC1_DAT[3:0] transition | 1.2 | 6.35 | ns |

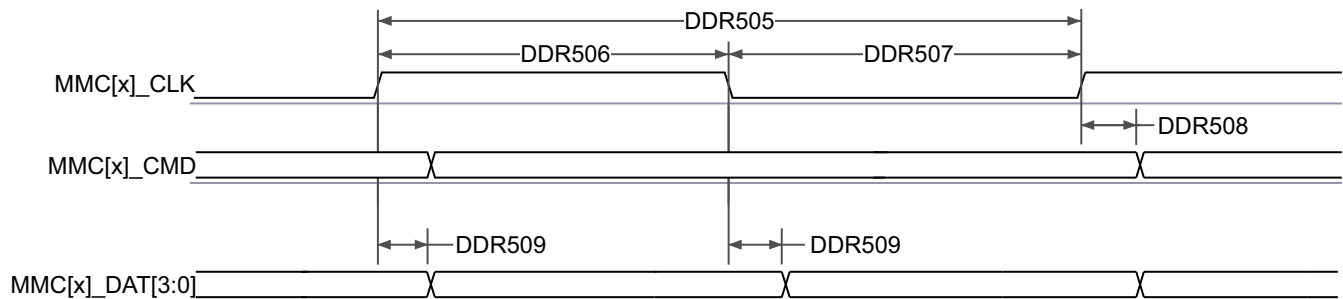

Figure 6-75. MMC1 – UHS-I DDR50 – Transmit Mode

6.11.5.12.2.7 UHS-I SDR104 Mode

Table 6-94, and Figure 6-76 present switching characteristics for MMC1 – UHS-I SDR104 Mode.

Table 6-94. Switching Characteristics for MMC1 – UHS-I SDR104 Mode

see Figure 6-76

| NO. | PARAMETER | | MIN | MAX | UNIT |
|---------|--------------------|--|------|-----|------|
| | $f_{op}(clk)$ | Operating frequency, MMC1_CLK | | 200 | MHz |
| SDR1045 | $t_{c}(clk)$ | Cycle time, MMC1_CLK | 5 | | ns |
| SDR1046 | $t_{w}(clkH)$ | Pulse duration, MMC1_CLK high | 2.12 | | ns |
| SDR1047 | $t_{w}(clkL)$ | Pulse duration, MMC1_CLK low | 2.12 | | ns |
| SDR1048 | $t_{d}(clkL-cmdV)$ | Delay time, MMC1_CLK rising edge to MMC1_CMD transition | 1.08 | 3.2 | ns |
| SDR1049 | $t_{d}(clkL-dV)$ | Delay time, MMC1_CLK rising edge to MMC1_DAT[3:0] transition | 1.08 | 3.2 | ns |

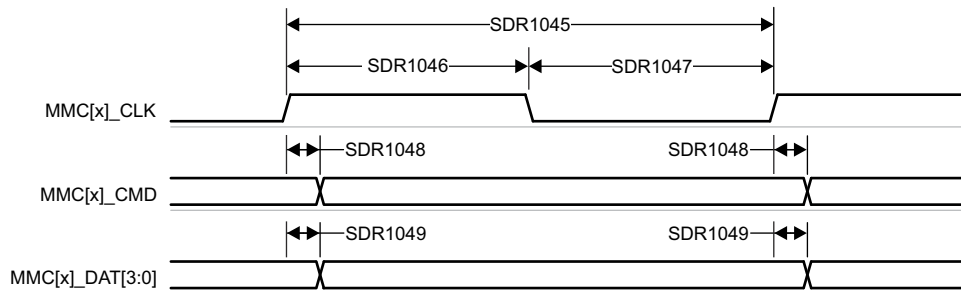

Figure 6-76. MMC1 – UHS-I SDR104 – Transmit Mode

6.11.5.13 CPTS

Table 6-95, Table 6-96, Figure 6-77, Table 6-97, and Figure 6-78 present timing conditions, timing requirements, and switching characteristics for CPTS.

Table 6-95. CPTS Timing Conditions

| PARAMETER | | MIN | MAX | UNIT |
|--------------------------|-------------------------|-----|-----|------|
| INPUT CONDITIONS | | | | |
| SR _i | Input slew rate | 0.5 | 5 | V/ns |
| OUTPUT CONDITIONS | | | | |
| C _L | Output load capacitance | 2 | 10 | pF |

Table 6-96. CPTS Timing Requirements

see Figure 6-77

| NO. | PARAMETER | DESCRIPTION | MIN | MAX | UNIT |
|-----|----------------------------|--------------------------------|------------------------|-----|------|
| T1 | t _w (HWTSPUSHH) | Pulse duration, HWnTSPUSH high | 12P ⁽¹⁾ + 2 | | ns |
| T2 | t _w (HWTSPUSHL) | Pulse duration, HWnTSPUSH low | 12P ⁽¹⁾ + 2 | | ns |
| T3 | t _c (RFT_CLK) | Cycle time, RFT_CLK | 5 | 8 | ns |
| T4 | t _w (RFT_CLKH) | Pulse duration, RFT_CLK high | 0.45T ⁽²⁾ | | ns |
| T5 | t _w (RFT_CLKL) | Pulse duration, RFT_CLK low | 0.45T ⁽²⁾ | | ns |

(1) P = functional clock period in ns.

(2) T = RFT_CLK period in ns.

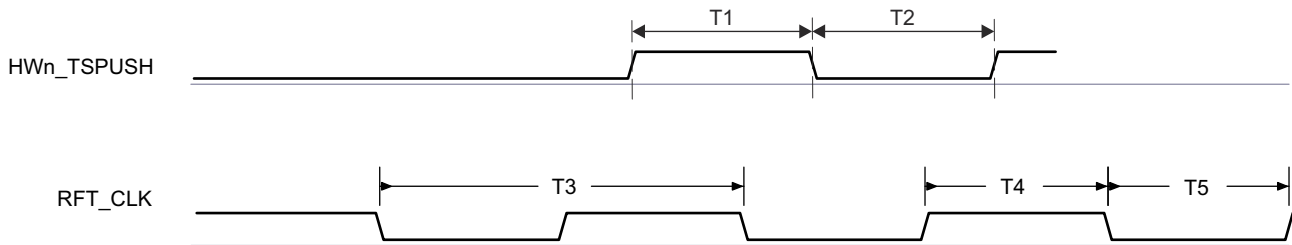

Figure 6-77. CPTS Timing Requirements

Table 6-97. CPTS Switching Characteristics

see [Figure 6-78](#)

| NO. | PARAMETER | DESCRIPTION | SOURCE | MIN | MAX | UNIT |
|-----|---------------------------|--------------------------------|---------|-----------------|-----|------|
| T6 | $t_w(\text{TS_COMP}_H)$ | Pulse duration, TS_COMP high | | $36P^{(1)} - 2$ | | ns |
| T7 | $t_w(\text{TS_COMPL})$ | Pulse duration, TS_COMP low | | $36P^{(1)} - 2$ | | ns |
| T8 | $t_w(\text{TS_SYNCH})$ | Pulse duration, TS_SYNC high | | $36P^{(1)} - 2$ | | ns |
| T9 | $t_w(\text{TS_SYNCL})$ | Pulse duration, TS_SYNC low | | $36P^{(1)} - 2$ | | ns |
| T10 | $t_w(\text{SYNCh_OUTH})$ | Pulse duration, SYNCh_OUT high | TS_SYNC | $36P^{(1)} - 2$ | | ns |
| | | | GENF | $5P^{(1)} - 2$ | | ns |
| T11 | $t_w(\text{SYNCL_OUTL})$ | Pulse duration, SYNCL_OUT low | TS_SYNC | $36P^{(1)} - 2$ | | ns |
| | | | GENF | $5P^{(1)} - 2$ | | ns |

(1) P = functional clock period in ns.

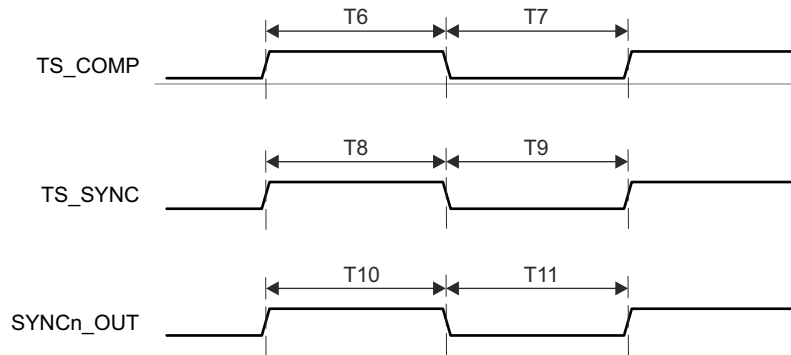

Figure 6-78. CPTS Switching Characteristics

For more information, see *Data Movement Architecture (DMA)* chapter in the device TRM.

6.11.5.14 OSPI

OSPI0 offers two data capture modes, PHY mode and Tap mode.

PHY mode uses an internal reference clock to transmit and receive data via a DLL based PHY, where each reference clock cycle produces a single cycle of OSPI0_CLK for Single Data Rate (SDR) transfers or a half cycle of OSPI0_CLK for Double Data Rate (DDR) transfers. PHY mode supports four clocking topologies for the receive data capture clock. Internal PHY Loopback - uses the internal reference clock as the PHY receive data capture clock. Internal Pad Loopback - uses OSPI0_LBCLKO looped back into the PHY from the OSPI0_LBCLKO pin as the PHY receive data capture clock. External Board Loopback - uses OSPI0_LBCLKO looped back into the PHY from the OSPI0_DQS pin as the PHY receive data capture clock. DQS - uses the DQS output from the attached device as the PHY receive data capture clock. SDR transfers are not supported when using the Internal Pad Loopback and DQS clocking topologies. DDR transfers are not supported when using the Internal PHY Loopback or Internal Pad Loopback clocking topologies.

Tap mode uses an internal reference clock with selectable taps to adjusted data transmit and receive capture delays relative to OSPI0_CLK, which is a divide by 4 of the internal reference clock for SDR transfers or a divide by 8 of the internal reference clock for DDR transfers. Tap mode only supports one clocking topology for the receive data capture clock. No Loopback - uses the internal reference clock as the Tap receive data capture clock. This clocking topology supports a maximum internal reference clock rate of 200MHz, which produces an OSPI0_CLK rate up to 50MHz for SDR mode or 25MHz for DDR mode.

For more details about features and additional description information on the device Octal Serial Peripheral Interface, see the corresponding subsections within *Signal Descriptions* and *Detailed Description* sections.

[Section 6.11.5.14.1](#) defines timing requirements and switching characteristics associated with PHY mode and [Section 6.11.5.14.2](#) defines timing requirements and switching characteristics associated with Tap mode.

[Table 6-98](#) presents timing conditions for OSPI0.

Table 6-98. OSPI0 Timing Conditions

| PARAMETER | | MODE | MIN | MAX | UNIT |
|---------------------------------------|---|---|------------------------|------------------------|------|
| INPUT CONDITIONS | | | | | |
| SR _I | Input slew rate | | 1 | 6 | V/ns |
| OUTPUT CONDITIONS | | | | | |
| C _L | Output load capacitance | | 3 | 10 | pF |
| PCB CONNECTIVITY REQUIREMENTS | | | | | |
| t _d (Trace Delay) | Propagation delay of OSPI0_CLK trace | No Loopback Internal PHY Loopback Internal Pad Loopback | | 450 | ps |
| | Propagation delay of OSPI0_LBCLKO trace | External Board Loopback | 2L ⁽¹⁾ - 30 | 2L ⁽¹⁾ + 30 | ps |
| | Propagation delay of OSPI0_DQS trace | DQS | L ⁽¹⁾ - 30 | L ⁽¹⁾ + 30 | ps |
| t _d (Trace Mismatch Delay) | Propagation delay mismatch of OSPI0_D[7:0] and OSPI0_CSn[3:0] relative to OSPI0_CLK | All modes | | 60 | ps |

(1) L = Propagation delay of OSPI0_CLK trace

For more information, see *Octal Serial Peripheral Interface (OSPI)* section in *Peripherals* chapter in the device TRM.

6.11.5.14.1 OSPI0 PHY Mode

6.11.5.14.1.1 OSPI0 With PHY Data Training

Read and write data valid windows will shift due to variation in process, voltage, temperature, and operating frequency. A data training method may be implemented to dynamically configure optimal read and write timing. Implementing data training enables proper operation across temperature with a specific process, voltage, and frequency operating condition, while achieving a higher operating frequency.

Data transmit and receive timing parameters are not defined for the data training use case since they are dynamically adjusted based on the operating condition.

Table 6-99 defines DLL delays required for OSPI0 with Data Training. Table 6-100, Figure 6-79, Table 6-101, and Figure 6-80 present timing requirements and switching characteristics for OSPI0 with Data Training.

Table 6-99. OSPI0 DLL Delay Mapping for PHY Data Training

| MODE | REGISTER BIT FIELD | DELAY VALUE |
|-----------------------------------|--------------------------------------|-------------|
| OSPI_PHY_CONFIGURATION_REG | | |
| Transmit | | |
| All modes | PHY_CONFIG_TX_DLL_DELAY_FLD | (1) |
| Receive | | |
| All modes | PHY_CONFIG_RX_DLL_DELAY_FLD | (2) |
| PHY_MASTER_CONTROL_REG | | |
| All modes | PHY_MASTER_PHASE_DETECT_SELECTOR_FLD | 0x3 |

- (1) Transmit DLL delay value determined by training software
- (2) Receive DLL delay value determined by training software

Table 6-100. OSPI0 Timing Requirements – PHY Data Training

see Figure 6-79

| NO. | | | MODE | MIN | MAX | UNIT |
|-----|-------------------|---|--------------|-----|-----|------|
| O15 | $t_{su(D-LBCLK)}$ | Setup time, OSPI0_D[7:0] valid before active OSPI0_DQS edge | DDR with DQS | (1) | | ns |
| O16 | $t_{h(LBCLK-D)}$ | Hold time, OSPI0_D[7:0] valid after active OSPI0_DQS edge | DDR with DQS | (1) | | ns |

- (1) Minimum setup and hold time requirements for OSPI0_D[7:0] inputs are not defined when Data Training is used to find the optimum data valid window.

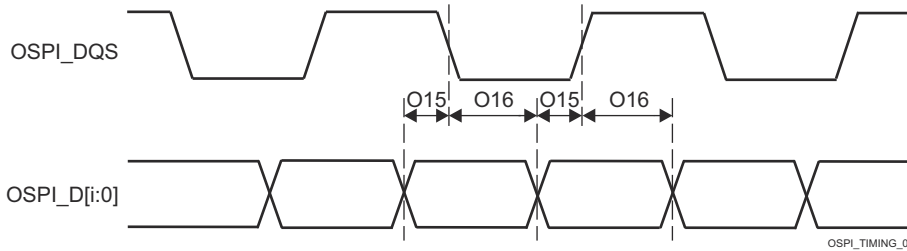

Figure 6-79. OSPI0 Timing Requirements – PHY Data Training, DDR with DQS

Table 6-101. OSPI0 Switching Characteristics – PHY Data Training

See [Figure 6-80](#)

| NO. | PARAMETER | | MODE | MIN | MAX | UNIT |
|-----|------------------|---|-----------|---|---|------|
| O1 | $t_{c(CLK)}$ | Cycle time, OSPI0_CLK | 1.8V, DDR | 6.02 | 7.52 | ns |
| | | | 3.3V, DDR | 7.52 | 7.52 | ns |
| O2 | $t_{w(CLKL)}$ | Pulse duration, OSPI0_CLK low | DDR | $((0.475P^{(1)}) - 0.3)$ | | ns |
| O3 | $t_{w(CLKH)}$ | Pulse duration, OSPI0_CLK high | DDR | $((0.475P^{(1)}) - 0.3)$ | | ns |
| O4 | $t_{d(CSn-CLK)}$ | Delay time, OSPI0_CSn[3:0] active edge to OSPI0_CLK rising edge | DDR | $((0.475P^{(1)}) + (0.975M^{(2)}R^{(4)}) + (0.04TD^{(5)}) - 1)$ | $((0.525P^{(1)}) + (1.025M^{(2)}R^{(4)}) + (0.11TD^{(5)}) + 1)$ | ns |
| O5 | $t_{d(CLK-CSn)}$ | Delay time, OSPI0_CLK rising edge to OSPI0_CSn[3:0] inactive edge | DDR | $((0.475P^{(1)}) + (0.975N^{(3)}R^{(4)}) - (0.11TD^{(5)}) - 1)$ | $((0.525P^{(1)}) + (1.025N^{(3)}R^{(4)}) - (0.04TD^{(5)}) + 1)$ | ns |
| O6 | $t_{d(CLK-D)}$ | Delay time, OSPI0_CLK active edge to OSPI0_D[7:0] transition | DDR | (6) | (6) | ns |

- (1) P = SCLK cycle time in ns = OSPI0_CLK cycle time in ns
- (2) M = OSPI_DEV_DELAY_REG[D_INIT_FLD]
- (3) N = OSPI_DEV_DELAY_REG[D_AFTER_FLD]
- (4) R = reference clock cycle time in ns
- (5) TD = PHY_CONFIG_TX_DLL_DELAY_FLD
- (6) Minimum and maximum delay times for OSPI0_D[7:0] outputs are not defined when Data Training is used to find the optimum data valid window.

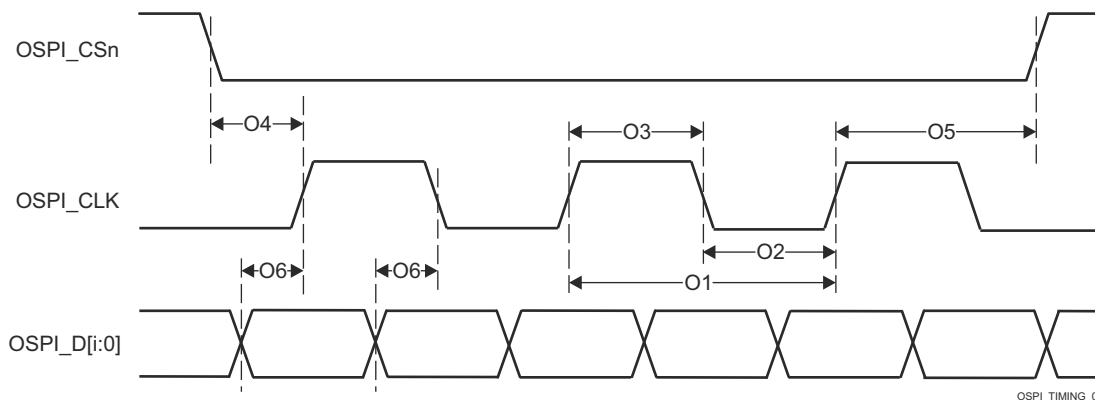

Figure 6-80. OSPI0 Switching Characteristics – PHY DDR Data Training

6.11.5.14.1.2 OSPI0 Without Data Training

Note

Timing parameters defined in this section are only applicable when data training is not implemented and DLL delays are configured as described in Table 6-102 and Table 6-105.

6.11.5.14.1.2.1 OSPI0 PHY SDR Timing

Table 6-102 defines DLL delays required for OSPI0 PHY SDR Mode. Table 6-103, Figure 6-81, Figure 6-82, Table 6-104, and Figure 6-83 present timing requirements and switching characteristics for OSPI0 PHY SDR Mode.

Table 6-102. OSPI0 DLL Delay Mapping for PHY SDR Timing Modes

| MODE | REGISTER BIT FIELD | DELAY VALUE |
|-----------------------------------|--------------------------------------|-------------|
| OSPI_PHY_CONFIGURATION_REG | | |
| Transmit | | |
| All modes | PHY_CONFIG_TX_DLL_DELAY_FLD | 0x0 |
| Receive | | |
| All modes | PHY_CONFIG_RX_DLL_DELAY_FLD | 0x0 |
| PHY_MASTER_CONTROL_REG | | |
| All modes | PHY_MASTER_PHASE_DETECT_SELECTOR_FLD | 0x3 |

Table 6-103. OSPI0 Timing Requirements – PHY SDR Mode

see Figure 6-81 and Figure 6-82

| NO. | | MODE | MIN | MAX | UNIT |
|-----|-------------------|---|--|------|------|
| O19 | $t_{su(D-CLK)}$ | Setup time, OSPI0_D[7:0] valid before active OSPI0_CLK edge | 1.8V, SDR with Internal PHY Loopback | 4.8 | ns |
| | | | 3.3V, SDR with Internal PHY Loopback | 5.19 | ns |
| O20 | $t_{h(CLK-D)}$ | Hold time, OSPI0_D[7:0] valid after active OSPI0_CLK edge | 1.8V, SDR with Internal PHY Loopback | -0.5 | ns |
| | | | 3.3V, SDR with Internal PHY Loopback | -0.5 | ns |
| O21 | $t_{su(D-LBCLK)}$ | Setup time, OSPI0_D[7:0] valid before active OSPI0_DQS edge | 1.8V, SDR with External Board Loopback | 0.6 | ns |
| | | | 3.3V, SDR with External Board Loopback | 0.9 | ns |
| O22 | $t_{h(LBCLK-D)}$ | Hold time, OSPI0_D[7:0] valid after active OSPI0_DQS edge | 1.8V, SDR with External Board Loopback | 1.7 | ns |
| | | | 3.3V, SDR with External Board Loopback | 2.0 | ns |

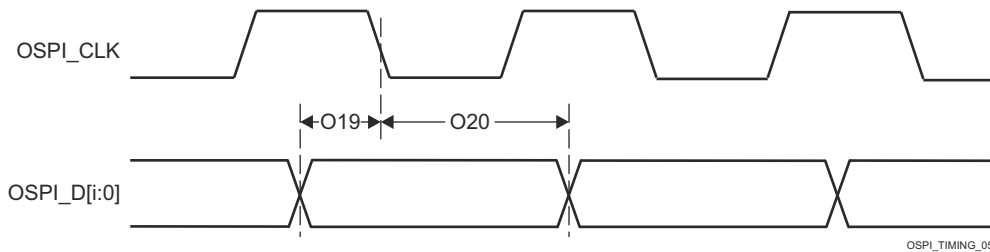

Figure 6-81. OSPI0 Timing Requirements – PHY SDR with Internal PHY Loopback



Figure 6-82. OSPI0 Timing Requirements – PHY SDR with External Board Loopback

Table 6-104. OSPI0 Switching Characteristics – PHY SDR Mode

see [Figure 6-83](#)

| NO. | PARAMETER | | MODE | MIN | MAX | UNIT |
|-----|------------------|---|------|--|--|------|
| O7 | $t_{c(CLK)}$ | Cycle time, OSPI0_CLK | 1.8V | 7 | | ns |
| | | | 3.3V | 6.03 | | ns |
| O8 | $t_{w(CLKL)}$ | Pulse duration, OSPI0_CLK low | | $((0.475P^{(1)}) - 0.3)$ | | ns |
| O9 | $t_{w(CLKH)}$ | Pulse duration, OSPI0_CLK high | | $((0.475P^{(1)}) - 0.3)$ | | ns |
| O10 | $t_{d(CSn-CLK)}$ | Delay time, OSPI0_CSn[3:0] active edge to OSPI0_CLK rising edge | | $((0.475P^{(1)}) + (0.975M^{(2)}R^{(4)}) + (0.04TD^{(5)} - 1)$ | $((0.525P^{(1)}) + (1.025M^{(2)}R^{(4)}) + (0.11TD^{(5)} + 1)$ | ns |
| O11 | $t_{d(CLK-CSn)}$ | Delay time, OSPI0_CLK rising edge to OSPI0_CSn[3:0] inactive edge | | $((0.475P^{(1)}) + (0.975N^{(3)}R^{(4)}) - (0.11TD^{(5)} - 1)$ | $((0.525P^{(1)}) + (1.025N^{(3)}R^{(4)}) - (0.04TD^{(5)} + 1)$ | ns |
| O12 | $t_{d(CLK-D)}$ | Delay time, OSPI0_CLK active edge to OSPI0_D[7:0] transition | 1.8V | -1.16 | 1.25 | ns |
| | | | 3.3V | -1.33 | 1.51 | ns |

- (1) P = SCLK cycle time in ns = OSPI0_CLK cycle time in ns
- (2) M = OSPI_DEV_DELAY_REG[D_INIT_FLD]
- (3) N = OSPI_DEV_DELAY_REG[D_AFTER_FLD]
- (4) R = reference clock cycle time in ns
- (5) TD = PHY_CONFIG_TX_DLL_DELAY_FLD

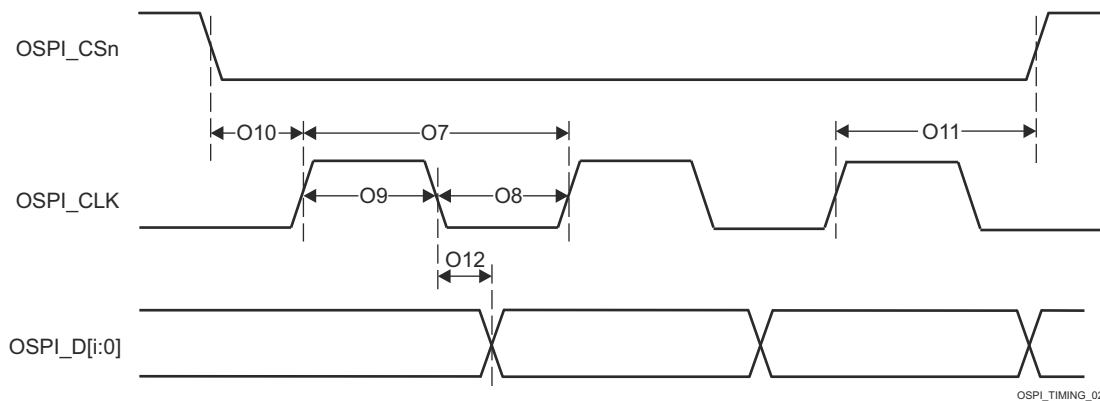

Figure 6-83. OSPI0 Switching Characteristics – PHY SDR

6.11.5.14.1.2.2 OSPI0 PHY DDR Timing

Table 6-105 defines DLL delays required for OSPI0 PHY DDR Mode. Table 6-106, Figure 6-84, Table 6-107, and Figure 6-85 present timing requirements and switching characteristics for OSPI0 PHY DDR Mode.

Table 6-105. OSPI0 DLL Delay Mapping for PHY DDR Timing Modes

| MODE | REGISTER BIT FIELD | DELAY VALUE |
|-----------------------------------|--------------------------------------|-------------|
| OSPI_PHY_CONFIGURATION_REG | | |
| Transmit | | |
| 1.8V | PHY_CONFIG_TX_DLL_DELAY_FLD | 0x3E |
| 3.3V | PHY_CONFIG_TX_DLL_DELAY_FLD | 0x3B |
| Receive | | |
| 1.8V, DQS | PHY_CONFIG_RX_DLL_DELAY_FLD | 0x15 |
| 3.3V, DQS | PHY_CONFIG_RX_DLL_DELAY_FLD | 0x3A |
| All other modes | PHY_CONFIG_RX_DLL_DELAY_FLD | 0x0 |
| PHY_MASTER_CONTROL_REG | | |
| All modes | PHY_MASTER_PHASE_DETECT_SELECTOR_FLD | 0x3 |

Table 6-106. OSPI0 Timing Requirements – PHY DDR Mode

see Figure 6-84

| NO. | | MODE | MIN | MAX | UNIT |
|-----|-------------------|---|--|---------------------|------|
| O15 | $t_{su(D-LBCLK)}$ | Setup time, OSPI0_D[7:0] valid before active OSPI0_DQS edge | 1.8V, DDR with External Board Loopback | 0.53 | ns |
| | | | 1.8V, DDR with DQS | -0.46 | ns |
| | | | 3.3V, DDR with External Board Loopback | 1.23 | ns |
| | | | 3.3V, DDR with DQS | -0.66 | ns |
| O16 | $t_{h(LBCLK-D)}$ | Hold time, OSPI0_D[7:0] valid after active OSPI0_DQS edge | 1.8V, DDR with External Board Loopback | 1.24 ⁽¹⁾ | ns |
| | | | 1.8V, DDR with DQS | 3.59 | ns |
| | | | 3.3V, DDR with External Board Loopback | 1.44 ⁽¹⁾ | ns |
| | | | 3.3V, DDR with DQS | 7.92 | ns |

- (1) This Hold time requirement is larger than the Hold time provided by a typical OSPI/QSPI/SPI device. Therefore, the trace length between the SoC and attached OSPI/QSPI/SPI device must be sufficiently long enough to ensure that the Hold time is met at the SoC. The length of the SoC's external loopback clock (OSPI0_LBCLKO to OSPI0_DQS) may need to be shortened to compensate.

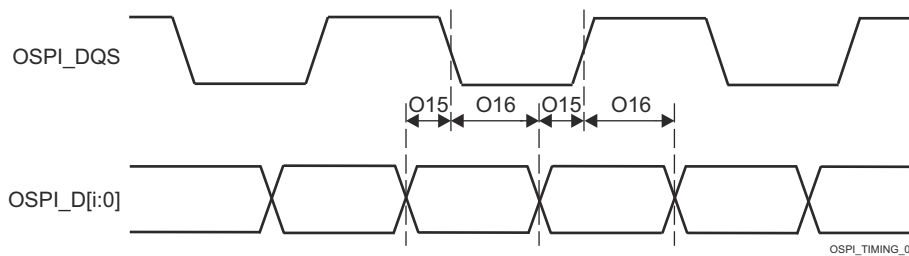

Figure 6-84. OSPI0 Timing Requirements – PHY DDR with External Board Loopback or DQS

Table 6-107. OSPI0 Switching Characteristics – PHY DDR Mode

see [Figure 6-85](#)

| NO. | PARAMETER | | MODE | MIN | MAX | UNIT |
|-----|------------------|---|------|---|---|------|
| O1 | $t_{c(CLK)}$ | Cycle time, OSPI0_CLK | | 19 | | ns |
| O2 | $t_{w(CLKL)}$ | Pulse duration, OSPI0_CLK low | | $((0.475P^{(1)}) - 0.3)$ | | ns |
| O3 | $t_{w(CLKH)}$ | Pulse duration, OSPI0_CLK high | | $((0.475P^{(1)}) - 0.3)$ | | ns |
| O4 | $t_{d(CSn-CLK)}$ | Delay time, OSPI0_CSn[3:0] active edge to OSPI0_CLK rising edge | | $((0.475P^{(1)}) + (0.975M^{(2)}R^{(4)}) + (0.04TD^{(5)} - 1))$ | $((0.525P^{(1)}) + (1.025M^{(2)}R^{(4)}) + (0.11TD^{(5)} + 1))$ | ns |
| O5 | $t_{d(CLK-CSn)}$ | Delay time, OSPI0_CLK rising edge to OSPI0_CSn[3:0] inactive edge | | $((0.475P^{(1)}) + (0.975N^{(3)}R^{(4)}) - (0.11TD^{(5)} - 1))$ | $((0.525P^{(1)}) + (1.025N^{(3)}R^{(4)}) - (0.04TD^{(5)} + 1))$ | ns |
| O6 | $t_{d(CLK-D)}$ | Delay time, OSPI0_CLK active edge to OSPI0_D[7:0] transition | 1.8V | -7.71 | -1.56 | ns |
| | | | 3.3V | -7.71 | -1.56 | ns |

- (1) P = SCLK cycle time in ns = OSPI0_CLK cycle time in ns
- (2) M = OSPI_DEV_DELAY_REG[D_INIT_FLD]
- (3) N = OSPI_DEV_DELAY_REG[D_AFTER_FLD]
- (4) R = reference clock cycle time in ns
- (5) TD = PHY_CONFIG_TX_DLL_DELAY_FLD

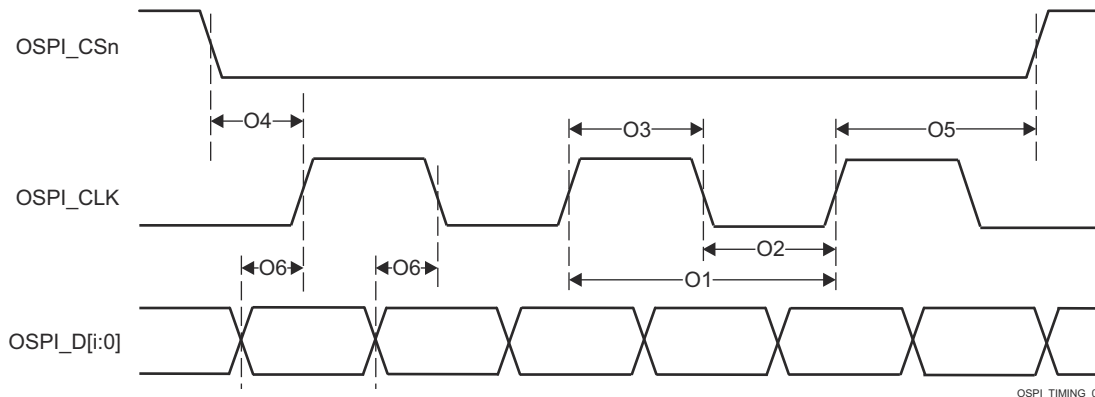

Figure 6-85. OSPI0 Switching Characteristics – PHY DDR

6.11.5.14.2 OSPI0 Tap Mode

6.11.5.14.2.1 OSPI0 Tap SDR Timing

Table 6-108, Figure 6-86, Table 6-109, and Figure 6-87 present timing requirements and switching characteristics for OSPI0 Tap SDR Mode.

Table 6-108. OSPI0 Timing Requirements – Tap SDR Mode

see Figure 6-86

| NO. | | | MODE | MIN | MAX | UNIT |
|-----|-----------------|---|-------------|---|-----|------|
| O19 | $t_{su(D-CLK)}$ | Setup time, OSPI0_D[7:0] valid before active OSPI0_CLK edge | No Loopback | (15.4 - (0.975T ⁽¹⁾ R ⁽²⁾)) | | ns |
| O20 | $t_{h(CLK-D)}$ | Hold time, OSPI0_D[7:0] valid after active OSPI0_CLK edge | No Loopback | (- 4.3 + (0.975T ⁽¹⁾ R ⁽²⁾)) | | ns |

(1) T = OSPI_RD_DATA_CAPTURE_REG[DELAY_FLD]

(2) R = reference clock cycle time in ns

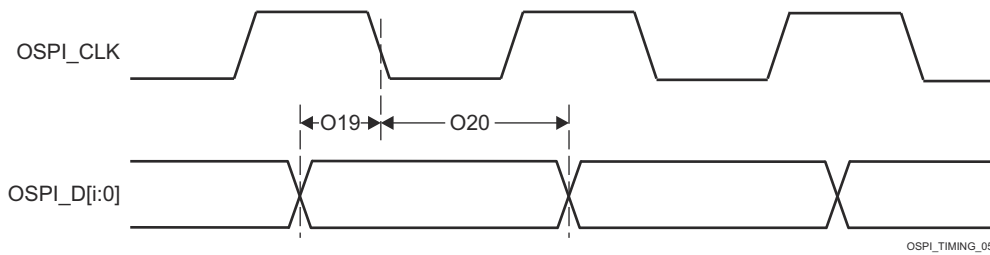

Figure 6-86. OSPI0 Timing Requirements – Tap SDR, No Loopback

Table 6-109. OSPI0 Switching Characteristics – Tap SDR Mode

see [Figure 6-87](#)

| NO. | PARAMETER | | MODE | MIN | MAX | UNIT |
|-----|------------------|---|------|--|--|------|
| O7 | $t_{c(CLK)}$ | Cycle time, OSPI0_CLK | | 20 | | ns |
| O8 | $t_{w(CLKL)}$ | Pulse duration, OSPI0_CLK low | | $((0.475P^{(1)}) - 0.3)$ | | ns |
| O9 | $t_{w(CLKH)}$ | Pulse duration, OSPI0_CLK high | | $((0.475P^{(1)}) - 0.3)$ | | ns |
| O10 | $t_{d(CSn-CLK)}$ | Delay time, OSPI0_CSn[3:0] active edge to OSPI0_CLK rising edge | | $((0.475P^{(1)}) + (0.975M^{(2)}R^{(4)}) - 1)$ | $((0.525P^{(1)}) + (1.025M^{(2)}R^{(4)}) + 1)$ | ns |
| O11 | $t_{d(CLK-CSn)}$ | Delay time, OSPI0_CLK rising edge to OSPI0_CSn[3:0] inactive edge | | $((0.475P^{(1)}) + (0.975N^{(3)}R^{(4)}) - 1)$ | $((0.525P^{(1)}) + (1.025N^{(3)}R^{(4)}) + 1)$ | ns |
| O12 | $t_{d(CLK-D)}$ | Delay time, OSPI0_CLK active edge to OSPI0_D[7:0] transition | | - 4.25 | 7.25 | ns |

- (1) P = SCLK cycle time in ns = OSPI0_CLK cycle time in ns
- (2) M = OSPI_DEV_DELAY_REG[D_INIT_FLD]
- (3) N = OSPI_DEV_DELAY_REG[D_AFTER_FLD]
- (4) R = reference clock cycle time in ns

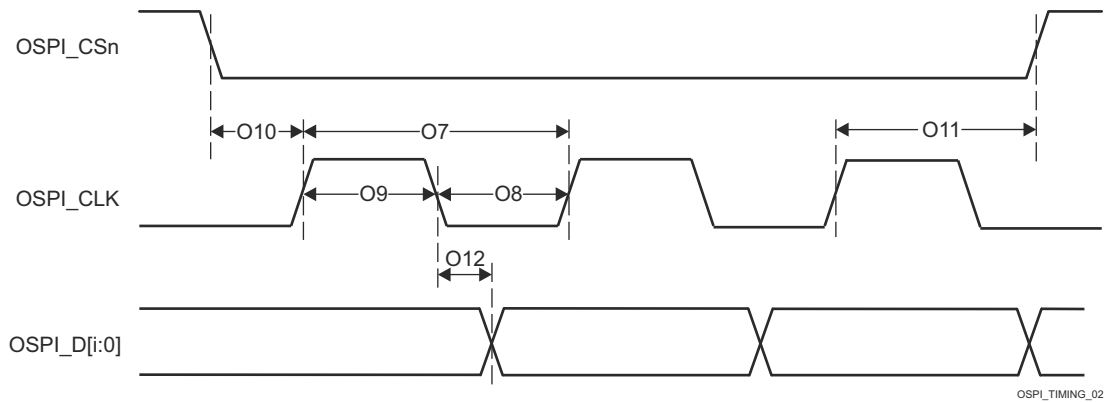

Figure 6-87. OSPI0 Switching Characteristics – Tap SDR, No Loopback

6.11.5.14.2.2 OSPI0 Tap DDR Timing

Table 6-110, Figure 6-88, Table 6-111, and Figure 6-89 present timing requirements and switching characteristics for OSPI0 Tap DDR Mode.

Table 6-110. OSPI0 Timing Requirements – Tap DDR Mode

see Figure 6-88

| NO. | | | MODE | MIN | MAX | UNIT |
|-----|-----------------|---|-------------|--|-----|------|
| O13 | $t_{su(D-CLK)}$ | Setup time, OSPI0_D[7:0] valid before active OSPI0_CLK edge | No Loopback | (17.04 - (0.975T ⁽¹⁾ R ⁽²⁾)) | | ns |
| O14 | $t_{h(CLK-D)}$ | Hold time, OSPI0_D[7:0] valid after active OSPI0_CLK edge | No Loopback | (- 3.16 + (0.975T ⁽¹⁾ R ⁽²⁾)) | | ns |

(1) T = OSPI_RD_DATA_CAPTURE_REG[DELAY_FLD]

(2) R = reference clock cycle time in ns

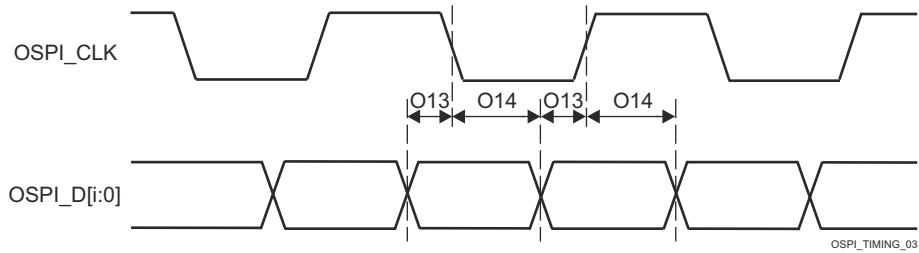

Figure 6-88. OSPI0 Timing Requirements – Tap DDR, No Loopback

Table 6-111. OSPI0 Switching Characteristics – Tap DDR Mode

see [Figure 6-89](#)

| NO. | PARAMETER | | MODE | MIN | MAX | UNIT |
|-----|------------------|---|------|---|---|------|
| O1 | $t_{c(CLK)}$ | Cycle time, OSPI0_CLK | | 40 | | ns |
| O2 | $t_{w(CLKL)}$ | Pulse duration, OSPI0_CLK low | | $((0.475P^{(1)}) - 0.3)$ | | ns |
| O3 | $t_{w(CLKH)}$ | Pulse duration, OSPI0_CLK high | | $((0.475P^{(1)}) - 0.3)$ | | ns |
| O4 | $t_{d(CSn-CLK)}$ | Delay time, OSPI0_CSn[3:0] active edge to OSPI0_CLK rising edge | | $((0.475P^{(1)}) + ((0.975M^{(2)}R^{(5)}) - 1))$ | $((0.525P^{(1)}) + (1.025M^{(2)}R^{(5)}) + 1)$ | ns |
| O5 | $t_{d(CLK-CSn)}$ | Delay time, OSPI0_CLK rising edge to OSPI0_CSn[3:0] inactive edge | | $((0.475P^{(1)}) + (0.975N^{(3)}R^{(5)}) - 1)$ | $((0.525P^{(1)}) + (1.025N^{(3)}R^{(5)}) + 1)$ | ns |
| O6 | $t_{d(CLK-D)}$ | Delay time, OSPI0_CLK active edge to OSPI0_D[7:0] transition | | $(- 5.04 + (0.975(T^{(4)} + 1)R^{(5)}) - (0.525P^{(1)}))$ | $(3.64 + (1.025(T^{(4)} + 1)R^{(5)}) - (0.475P^{(1)}))$ | ns |

- (1) P = SCLK cycle time in ns = OSPI0_CLK cycle time in ns
- (2) M = OSPI_DEV_DELAY_REG[D_INIT_FLD]
- (3) N = OSPI_DEV_DELAY_REG[D_AFTER_FLD]
- (4) T = OSPI_RD_DATA_CAPTURE_REG[DDR_READ_DELAY_FLD]
- (5) R = reference clock cycle time in ns

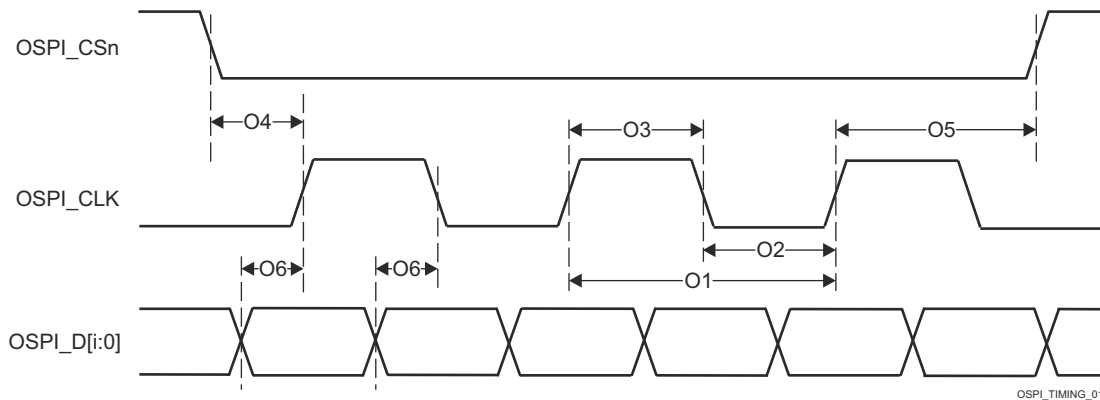

Figure 6-89. OSPI0 Switching Characteristics – Tap DDR, No Loopback

6.11.5.15 PCIe

The PCI-Express Subsystem is compliant with the PCIe® Base Specification, Revision 4.0. Refer to the specification for timing details.

For more details about features and additional description information on the device Peripheral Component Interconnect Express (PCIe), see the *SERDES0 Signal Descriptions* and the corresponding subsection within *Detailed Description*.

For more information, see *Peripheral Component Interconnect Express (PCIe) Subsystem* section in *Peripherals* chapter of the device TRM.

6.11.5.16 PRU_ICSSG

The device has integrated two identical Programmable Real-Time Unit Subsystem and Industrial Communication Subsystems - Gigabit (PRU_ICSSG), PRU_ICSSG0 and PRU_ICSSG1. The programmable nature of the PRU cores, along with their access to pins, events and all device resources, provides flexibility in implementing fast real-time responses, specialized data handling operations, custom peripheral interfaces, and in offloading tasks from the other processor cores in the device.

For more details about features and additional description information on the device PRU_ICSSG, see the corresponding subsections within *Signal Descriptions* and *Detailed Description* sections.

Note

The PRU_ICSSG contains a second layer of multiplexing to enable additional functionality on the PRU GPO and GPI signals. This internal wrapper multiplexing is described in the PRU_ICSSG chapter in the device TRM.

6.11.5.16.1 PRU_ICSSG Programmable Real-Time Unit (PRU)

Note

The PRU_ICSSG PRU signals have different functionality depending on the mode of operation. The signal naming in this section matches the naming used in the *PRU Module Interface* section in the device TRM.

Table 6-112. PRU_ICSSG PRU Timing Conditions

| PARAMETER | | MIN | MAX | UNIT |
|--------------------------|-------------------------|-----|-----|------|
| INPUT CONDITIONS | | | | |
| SR _I | Input slew rate | 1 | 3 | V/ns |
| OUTPUT CONDITIONS | | | | |
| C _L | Output load capacitance | 2 | 30 | pF |

6.11.5.16.1.1 PRU_ICSSG PRU Direct Output Mode Timing

Table 6-113. PRU_ICSSG PRU Switching Characteristics – Direct Output Mode

see [Figure 6-90](#)

| NO. | PARAMETER | DESCRIPTION | MIN | MAX | UNIT |
|-------|--------------------------|------------------|-----|-----|------|
| PRDO1 | t _{sk(GPO-GPO)} | Skew, GPO to GPO | | 2 | ns |

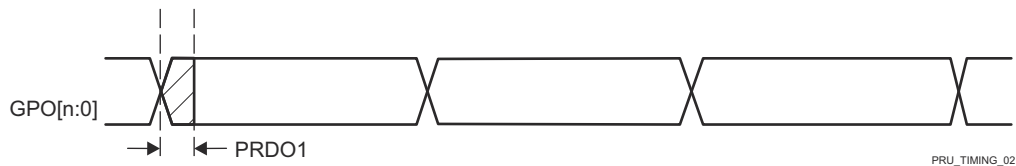

A. n in GPO[n:0] = 19.

Figure 6-90. PRU_ICSSG PRU Direct Output Timing

6.11.5.16.1.2 PRU_ICSSG PRU Parallel Capture Mode Timing

Table 6-114. PRU_ICSSG PRU Timing Requirements – Parallel Capture Mode

see [Figure 6-91](#) and [Figure 6-92](#)

| NO. | PARAMETER | DESCRIPTION | MIN | MAX | UNIT |
|-------|------------------------|---|----------------------|-----|------|
| PRPC1 | $t_{c(CLOCK)}$ | Cycle time, CLOCKIN | 20 | | ns |
| PRPC2 | $t_{w(CLOCKL)}$ | Pulse duration, CLOCKIN low | 0.45P ⁽¹⁾ | | ns |
| PRPC3 | $t_{w(CLOCKH)}$ | Pulse duration, CLOCKIN high | 0.45P ⁽¹⁾ | | ns |
| PRPC4 | $t_{su(DATAIN-CLOCK)}$ | Setup time, DATAIN valid before CLOCKIN active edge | 4 | | ns |
| PRPC5 | $t_{h(CLOCK-DATAIN)}$ | Hold time, DATAIN valid after CLOCKIN active edge | 0 | | ns |

(1) P = CLOCKIN cycle time in ns

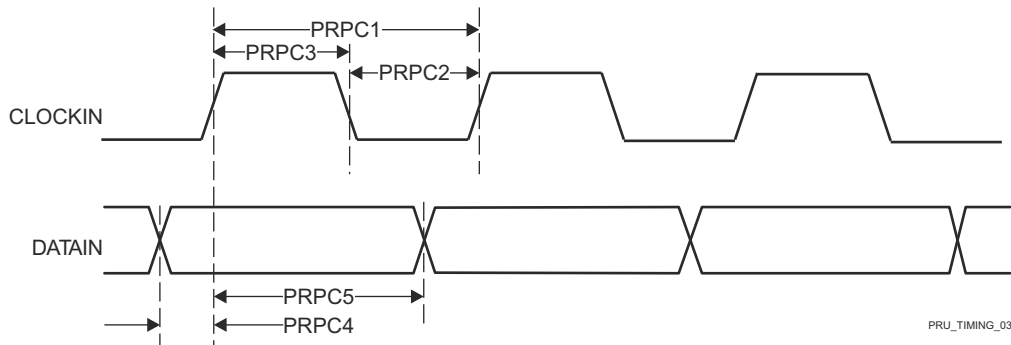

Figure 6-91. PRU_ICSSG PRU Parallel Capture Timing Requirements – Rising Edge Mode

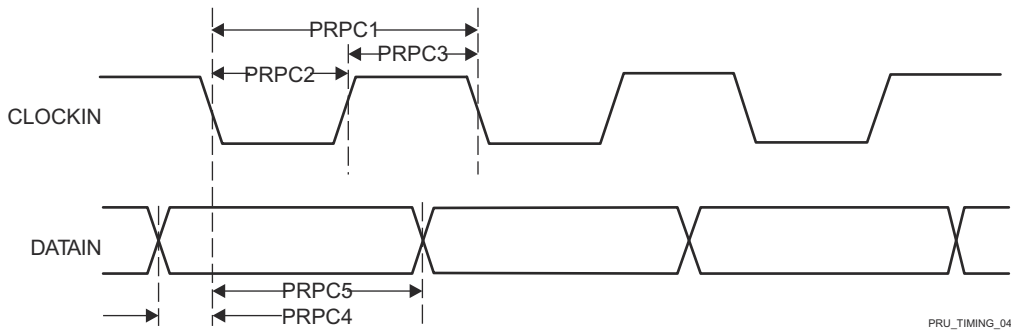

Figure 6-92. PRU_ICSSG PRU Parallel Capture Timing Requirements – Falling Edge Mode

6.11.5.16.1.3 PRU_ICSSG PRU Shift Mode Timing

Table 6-115. PRU_ICSSG PRU Timing Requirements – Shift In Mode

see [Figure 6-93](#)

| NO. | PARAMETER | DESCRIPTION | MIN | MAX | UNIT |
|-------|------------------|-----------------------------|----------------|-----|------|
| PRSI1 | $t_{W(DATAINH)}$ | Pulse duration, DATAIN high | $2P^{(1)} + 2$ | | ns |
| PRSI2 | $t_{W(DATAINL)}$ | Pulse duration, DATAIN low | $2P^{(1)} + 2$ | | ns |

- (1) P = Internal shift in clock period, defined by PRUn_GPI_DIV0 and PRUn_GPI_DIV1 bit fields in the ICSSG_GPCFGn_REG register. PRUn represents the respective PRU0 or PRU1 instance.

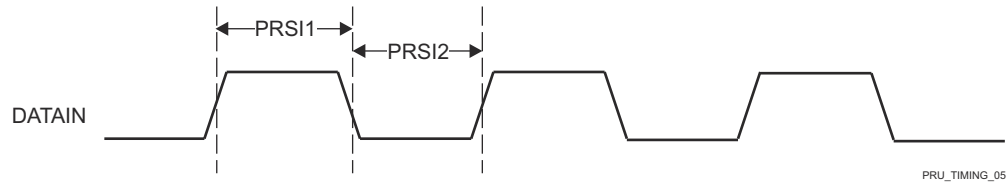

Figure 6-93. PRU_ICSSG PRU Shift In Timing

Table 6-116. PRU_ICSSG PRU Switching Characteristics – Shift Out Mode

see [Figure 6-94](#)

| NO. | PARAMETER | DESCRIPTION | MIN | MAX | UNIT |
|--------|----------------------------------|---------------------------------------|-----------------------------|-----|------|
| PRSO1 | $t_{c(\text{CLOCKOUT})}$ | Cycle time, CLOCKOUT | 10 | | ns |
| PRSO2L | $t_{w(\text{CLOCKOUTL})}$ | Pulse duration, CLOCKOUT low | $0.475P^{(1)}Z^{(2)} - 0.3$ | | ns |
| PRSO2H | $t_{w(\text{CLOCKOUTH})}$ | Pulse duration, CLOCKOUT high | $0.475P^{(1)}Y^{(3)} - 0.3$ | | ns |
| PRSO3 | $t_{d(\text{CLOCKOUT-DATAOUT})}$ | Delay time, CLOCKOUT to DATAOUT valid | -1 | 4 | ns |

- (1) P = Software programmable shift out clock period, defined by PRUn_GPO_DIV0 and PRUn_GPO_DIV1 bit fields in the ICSSG_GPCFGn_REG register, where PRUn represents the respective PRU0 or PRU1 instance.
- (2) The Z parameter is defined as follows, where PRUn represents the respective PRU0 or PRU1 instance.
 - a. If PRUn_GPI_DIV0 and PRUn_GPI_DIV1 are INTEGERS -or- if PRUn_GPI_DIV0 is a NON-INTEGER and PRUn_GPI_DIV1 is an EVEN INTEGER then, Z equals $(PRUn_GPI_DIV0 * PRUn_GPI_DIV1)$.
 - b. If PRUn_GPI_DIV0 is a NON-INTEGER and PRUn_GPI_DIV1 is an ODD INTEGER then, Z equals $(PRUn_GPI_DIV0 * PRUn_GPI_DIV1 + 0.5)$.
 - c. If PRUn_GPI_DIV0 is an INTEGER and PRUn_GPI_DIV1 is a NON-INTEGER then, Z equals $(PRUn_GPI_DIV0 * PRUn_GPI_DIV1 + 0.5 * PRUn_GPI_DIV0)$.
 - d. If PRUn_GPI_DIV0 and PRUn_GPI_DIV1 are NON-INTEGERS then, Z equals $(PRUn_GPI_DIV0 * PRUn_GPI_DIV1 + 0.25 * PRUn_GPI_DIV0)$.
- (3) The Y parameter is defined as follows, where PRUn represents the respective PRU0 or PRU1 instance.
 - a. If PRUn_GPI_DIV0 and PRUn_GPI_DIV1 are INTEGERS -or- if PRUn_GPI_DIV0 is a NON-INTEGER and PRUn_GPI_DIV1 is an EVEN INTEGER then, Y equals $(PRUn_GPI_DIV0 * PRUn_GPI_DIV1)$.
 - b. If PRUn_GPI_DIV0 is a NON-INTEGER and PRUn_GPI_DIV1 is an ODD INTEGER then, Y equals $(PRUn_GPI_DIV0 * PRUn_GPI_DIV1 - 0.5)$.
 - c. If PRUn_GPI_DIV0 is an INTEGER and PRUn_GPI_DIV1 is a NON-INTEGER then, Y equals $(PRUn_GPI_DIV0 * PRUn_GPI_DIV1 - 0.5 * PRUn_GPI_DIV0)$.
 - d. If PRUn_GPI_DIV0 and PRUn_GPI_DIV1 are NON-INTEGERS then, Y1 equals $(PRUn_GPI_DIV0 * PRUn_GPI_DIV1 - 0.25 * PRUn_GPI_DIV0)$ and Y2 equals $(PRUn_GPI_DIV0 * PRUn_GPI_DIV1 + 0.25 * PRUn_GPI_DIV0)$, where Y1 is the first high pulse and Y2 is the second high pulse.

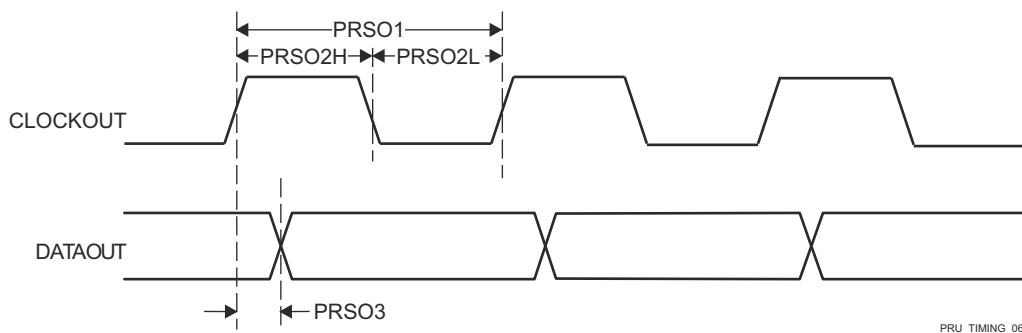

Figure 6-94. PRU_ICSSG PRU Shift Out Timing

6.11.5.16.1.4 PRU_ICSSG PRU Sigma Delta and Peripheral Interface

Table 6-117. PRU_ICSSG PRU Sigma Delta and Peripheral Interface Timing Conditions

| PARAMETER | | MIN | MAX | UNIT |
|--------------------------|-------------------------|-----|-----|------|
| INPUT CONDITIONS | | | | |
| SR _I | Input slew rate | 1 | 3 | V/ns |
| OUTPUT CONDITIONS | | | | |
| C _L | Output load capacitance | 2 | 18 | pF |

6.11.5.16.1.4.1 PRU_ICSSG PRU Sigma Delta and Peripheral Interface Timing

Table 6-118. PRU_ICSSG PRU Timing Requirements – Sigma Delta Mode

see Figure 6-95 and Figure 6-96

| NO. | PARAMETER | DESCRIPTION | MIN | MAX | UNIT |
|--------|-------------------------------|--|-----|-----|------|
| PRSD1 | t _c (SD_CLK) | Cycle time, SDx_CLK | 40 | | ns |
| PRSD2L | t _w (SD_CLKL) | Pulse duration, SDx_CLK low | 20 | | ns |
| PRSD2H | t _w (SD_CLKH) | Pulse duration, SDx_CLK high | 20 | | ns |
| PRSD3 | t _{su} (SD_D-SD_CLK) | Setup time, SDx_D valid before SDx_CLK active edge | 10 | | ns |
| PRSD4 | t _h (SD_CLK-SD_D) | Hold time, SDx_D valid after SDx_CLK active edge | 5 | | ns |

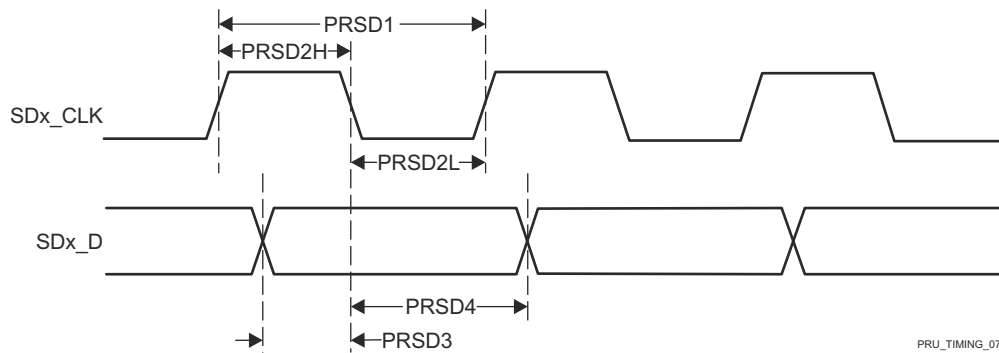

Figure 6-95. PRU_ICSSG PRU SD_CLK Falling Active Edge

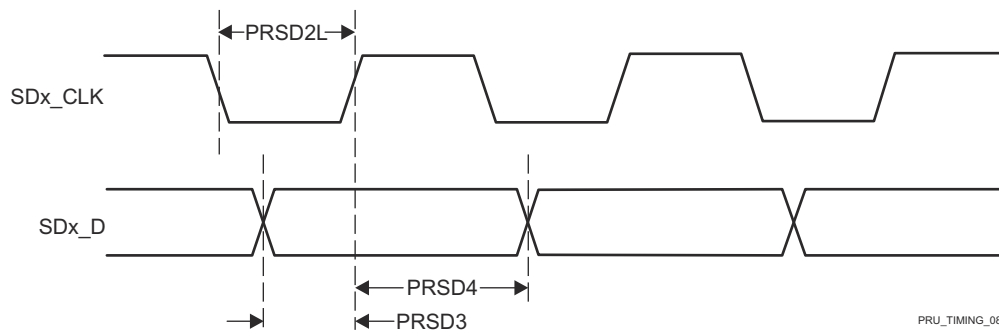

Figure 6-96. PRU_ICSSG PRU SD_CLK Rising Active Edge

Table 6-119. PRU_ICSSG PRU Timing Requirements – Peripheral Interface Mode

see [Figure 6-97](#)

| NO. | PARAMETER | DESCRIPTION | MIN | MAX | UNIT |
|--------|------------------------------|----------------------------------|-------------------------------------|-----|------|
| PRPIF1 | $t_w(\text{PIF_DATA_INH})$ | Pulse duration, PIF_DATA_IN high | $2 + 0.475 \cdot (4 \cdot P)^{(1)}$ | | ns |
| PRPIF2 | $t_w(\text{PIF_DATA_INL})$ | Pulse duration, PIF_DATA_IN low | $2 + 0.475 \cdot (4 \cdot P)^{(1)}$ | | ns |

(1) $P = 1x$ (or TX) clock period in ns, defined by PRUn_ED_TX_DIV_FACTOR and PRUn_ED_TX_DIV_FACTOR_FRAC in the ICSSG_PRUn_ED_TX_CFG_REG register. PRUn represents the respective PRU0 or PRU1 instance.

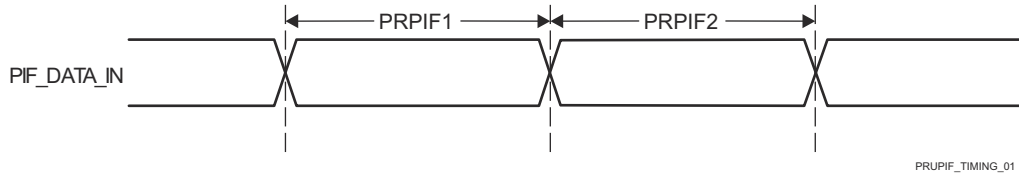

Figure 6-97. PRU_ICSSG PRU Peripheral Interface Timing Requirements

Table 6-120. PRU_ICSSG PRU Switching Characteristics – Peripheral Interface Mode

see [Figure 6-98](#)

| NO. | PARAMETER | DESCRIPTION | MIN | MAX | UNIT |
|--------|---------------------------------------|--|-----------------------|-----|------|
| PRPIF3 | $t_c(\text{PIF_CLK})$ | Cycle time, PIF_CLK | 30 | | ns |
| PRPIF4 | $t_w(\text{PIF_CLKH})$ | Pulse duration, PIF_CLK high | $0.475 \cdot P^{(1)}$ | | ns |
| PRPIF5 | $t_w(\text{PIF_CLKL})$ | Pulse duration, PIF_CLK low | $0.475 \cdot P^{(1)}$ | | ns |
| PRPIF6 | $t_d(\text{PIF_CLK-PIF_DATA_OUT})$ | Delay time, PIF_CLK fall to PIF_DATA_OUT | -5 | 5 | ns |
| PRPIF7 | $t_d(\text{PIF_CLK-PIF_DATA_EN})$ | Delay time, PIF_CLK fall to PIF_DATA_EN | -5 | 5 | ns |

(1) $P = 1x$ (or TX) clock period in ns, defined by PRUn_ED_TX_DIV_FACTOR and PRUn_ED_TX_DIV_FACTOR_FRAC in the ICSSG_PRUn_ED_TX_CFG_REG register. PRUn represents the respective PRU0 or PRU1 instance.

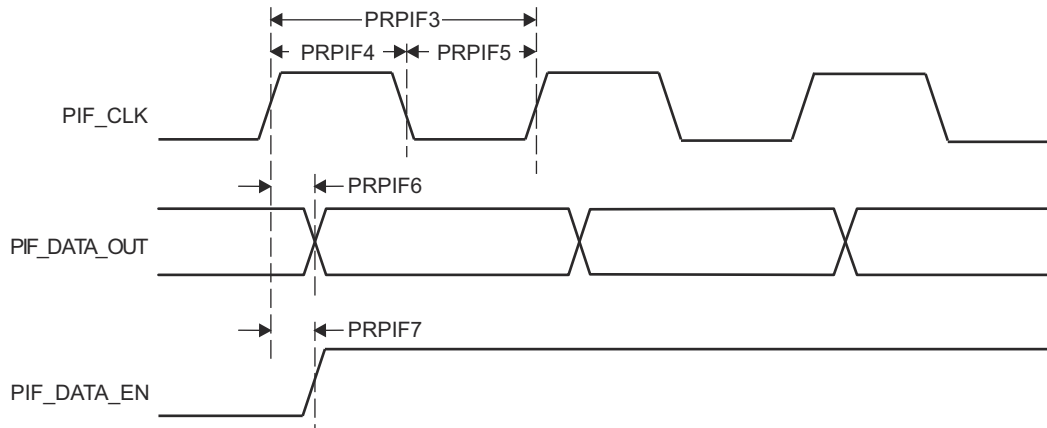

Figure 6-98. PRU_ICSSG PRU Peripheral Interface Switching Characteristics

6.11.5.16.2 PRU_ICSSG Pulse Width Modulation (PWM)

Table 6-121. PRU_ICSSG PWM Timing Conditions

| PARAMETER | | MIN | MAX | UNIT |
|--------------------------|-------------------------|-----|-----|------|
| INPUT CONDITIONS | | | | |
| SR _i | Input slew rate | 1 | 4 | V/ns |
| OUTPUT CONDITIONS | | | | |
| C _L | Output load capacitance | 2 | 7 | pF |

6.11.5.16.2.1 PRU_ICSSG PWM Timing

Table 6-122. PRU_ICSSG PWM Switching Characteristics

see Figure 6-99

| NO. | PARAMETER | DESCRIPTION | MIN | MAX | UNIT |
|--------|-------------------------------|----------------------|-----|-----|------|
| PRPWM1 | t _{sk} (PWM_A-PWM_B) | Skew, PWM_A to PWM_B | | 5 | ns |

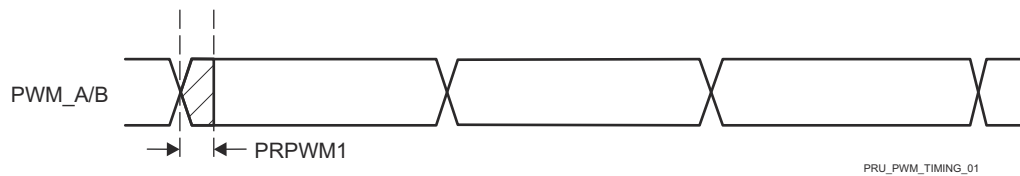

Figure 6-99. PRU_ICSSG PWM Timing

6.11.5.16.3 PRU_ICSSG Industrial Ethernet Peripheral (IEP)

Table 6-123. PRU_ICSSG IEP Timing Conditions

| PARAMETER | | MIN | MAX | UNIT | |
|--------------------------|-------------------------|--------------------------------|-----|------|----|
| INPUT CONDITIONS | | | | | |
| SR _I | Input slew rate | 1 | 3 | V/ns | |
| OUTPUT CONDITIONS | | | | | |
| C _L | Output load capacitance | EDC_SYNC_OUTx EDIO_OUTVALID | 2 | 7 | pF |
| | | EDIO_DATA_OUT | 3 | 10 | pF |

6.11.5.16.3.1 PRU_ICSSG IEP Timing

Table 6-124. PRU_ICSSG IEP Timing Requirements – Input Validated with SYNC

see Figure 6-100

| NO. | PARAMETER | DESCRIPTION | MIN | MAX | UNIT |
|--------|--|---|------------------------|-----|------|
| PRIEP1 | t _w (EDC_SYNC_OUTxL) | Pulse duration, EDC_SYNC_OUTx low | 20P ⁽¹⁾ - 2 | | ns |
| PRIEP2 | t _w (EDC_SYNC_OUTxH) | Pulse duration, EDC_SYNC_OUTx high | 20P ⁽¹⁾ - 2 | | ns |
| PRIEP3 | t _{su} (EDIO_DATA_IN- EDC_SYNC_OUTx) | Setup time, EDIO_DATA_IN valid before EDC_SYNC_OUTx active edge | 20 | | ns |
| PRIEP4 | t _h (EDC_SYNC_OUTx- EDIO_DATA_IN) | Hold time, EDIO_DATA_IN valid after EDC_SYNC_OUTx active edge | 20 | | ns |

(1) P = PRU_ICSSG IEP clock source period in ns.

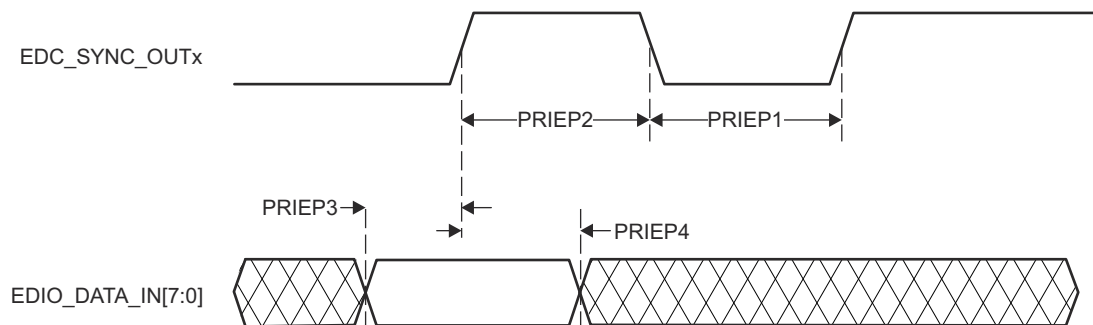

PRU_IEP_TIMING_01

Figure 6-100. PRU_ICSSG IEP SYNC Timing Requirements

Table 6-125. PRU_ICSSG IEP Switching Characteristics – Digital IOs

see Figure 6-101

| NO. | PARAMETER | DESCRIPTION | MIN | MAX | UNIT |
|--------|---|--|-----------------|-------------|------|
| IEPIO1 | $t_{w(EDIO_OUTVALIDL)}$ | Pulse duration, EDIO_OUTVALID low | $14P^{(1)} - 2$ | | ns |
| IEPIO2 | $t_{w(EDIO_OUTVALIDH)}$ | Pulse duration, EDIO_OUTVALID high | $32P^{(1)} - 2$ | | ns |
| IEPIO3 | $t_{d(EDIO_OUTVALID-EDIO_DATA_OUT)}$ | Delay time, EDIO_OUTVALID to EDIO_DATA_OUT | 0 | $18P^{(1)}$ | ns |
| IEPIO4 | $t_{sk(EDIO_DATA_OUT)}$ | EDIO_DATA_OUT skew | | 5 | ns |

(1) P = PRU_ICSSG IEP clock source period in ns.



Figure 6-101. PRU_ICSSG IEP Digital IOs Timing Requirements

Table 6-126. PRU_ICSSG IEP Timing Requirements – LATCH_INx

see Figure 6-102

| NO. | PARAMETER | DESCRIPTION | MIN | MAX | UNIT |
|-------|---------------------------|------------------------------------|----------------|-----|------|
| PRLA1 | $t_{w(EDC_LATCH_INxL)}$ | Pulse duration, EDC_LATCH_INx low | $3P^{(1)} + 2$ | | ns |
| PRLA2 | $t_{w(EDC_LATCH_INxH)}$ | Pulse duration, EDC_LATCH_INx high | $3P^{(1)} + 2$ | | ns |

(1) P = PRU_ICSSG IEP clock source period in ns.

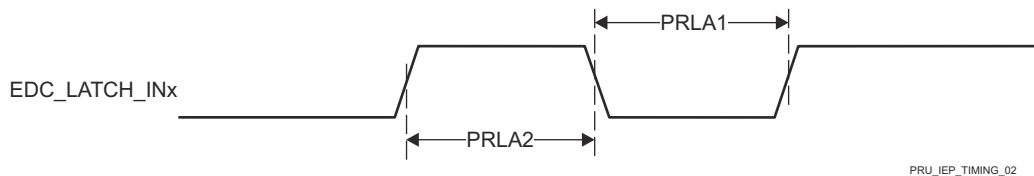

Figure 6-102. PRU_ICSSG IEP LATCH_INx Timing Requirements

6.11.5.16.4 PRU_ICSSG Universal Asynchronous Receiver Transmitter (UART)

Table 6-127. PRU_ICSSG UART Timing Conditions

| PARAMETER | | MIN | MAX | UNIT |
|--------------------------|-------------------------|-----|-------------------|------|
| INPUT CONDITIONS | | | | |
| SR _I | Input slew rate | 0.5 | 5 | V/ns |
| OUTPUT CONDITIONS | | | | |
| C _L | Output load capacitance | 1 | 30 ⁽¹⁾ | pF |

(1) This value represents an absolute maximum load capacitance. As the UART baud rate increases, it may be necessary to reduce the load capacitance to a value less than this maximum limit to provide enough timing margin for the attached device. The output rise/fall times increase as capacitive load increases, which decreases the time data is valid for the receiver of the attached devices. Therefore, it is important to understand the minimum data valid time required by the attached device at the operating baud rate. Then use the device IBIS models to verify the actual load capacitance on the UART signals does not increase the rise/fall times beyond the point where the minimum data valid time of the attached device is violated.

6.11.5.16.4.1 PRU_ICSSG UART Timing

Table 6-128. PRU_ICSSG UART Timing Requirements

see Figure 6-103

| NO. | PARAMETER | DESCRIPTION | MIN | MAX | UNIT |
|-----|----------------------|---|-----------------------------|-----------------------------|------|
| 1 | t _{w(RXD)} | Pulse width, receive data bit high or low | 0.95U ⁽¹⁾ (2) | 1.05U ⁽¹⁾ (2) | ns |
| 2 | t _{w(RXDS)} | Pulse width, receive start bit low | 0.95U ⁽¹⁾ (2) | | ns |

(1) U = UART baud time in ns = 1/programmed baud rate.

(2) This value defines the data valid time, where the input voltage is required to be above V_{IH} or below V_{IL}.

Table 6-129. PRU_ICSSG UART Switching Characteristics

see Figure 6-103

| NO. | PARAMETER | DESCRIPTION | MIN | MAX | UNIT |
|-----|----------------------|--|----------------------|----------------------|------|
| | f(baud) | Programmed baud rate | | 12 | Mbps |
| 3 | t _{w(TXD)} | Pulse width, transmit data bit high or low | U ⁽¹⁾ - 2 | U ⁽¹⁾ + 2 | ns |
| 4 | t _{w(TXDS)} | Pulse width, transmit start bit low | U ⁽¹⁾ - 2 | U ⁽¹⁾ + 2 | ns |

(1) U = UART baud time in ns = 1/actual baud rate, where the actual baud rate is defined in the UART Baud Rate Settings table of the device TRM.

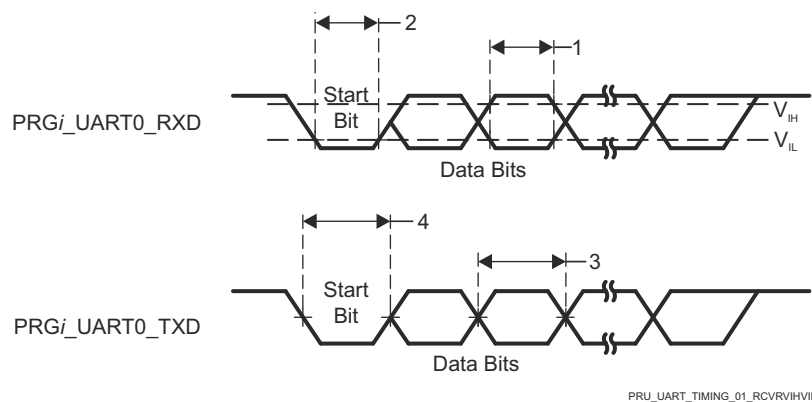

Figure 6-103. PRU_ICSSG UART Timing Requirements and Switching Characteristics

6.11.5.16.5 PRU_ICSSG Enhanced Capture Peripheral (ECAP)

Table 6-130. PRU_ICSSG ECAP Timing Conditions

| PARAMETER | | MIN | MAX | UNIT |
|--------------------------|-------------------------|-----|-----|------|
| INPUT CONDITIONS | | | | |
| SR _i | Input slew rate | 1 | 3 | V/ns |
| OUTPUT CONDITIONS | | | | |
| C _L | Output load capacitance | 2 | 7 | pF |

6.11.5.16.5.1 PRU_ICSSG ECAP Timing

Table 6-131. PRU_ICSSG ECAP Timing Requirements

see Figure 6-104

| NO. | PARAMETER | DESCRIPTION | MIN | MAX | UNIT |
|-------|------------------------|--------------------------------------|-----------------------|-----|------|
| PREP1 | t _w (CAP) | Pulse Duration, CAP (asynchronous) | 2P ⁽¹⁾ + 2 | | ns |
| PREP2 | t _w (SYNCI) | Pulse Duration, SYNCI (asynchronous) | 2P ⁽¹⁾ + 2 | | ns |

(1) P = CORE_CLK period in ns.

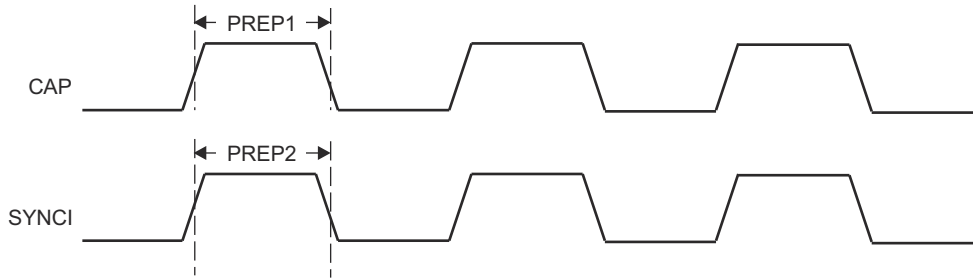

Figure 6-104. PRU_ICSSG ECAP Timing

Table 6-132. PRU_ICSSG ECAP Switching Characteristics

see Figure 6-105

| NO. | PARAMETER | DESCRIPTION | MIN | MAX | UNIT |
|-------|------------------------|--------------------------------------|-----------------------|-----|------|
| PREP3 | t _w (APWM) | Pulse Duration, APWM high/low | 2P ⁽¹⁾ - 2 | | ns |
| PREP4 | t _w (SYNCO) | Pulse Duration, SYNCO (asynchronous) | P ⁽¹⁾ - 2 | | ns |

(1) P = CORE_CLK period in ns.

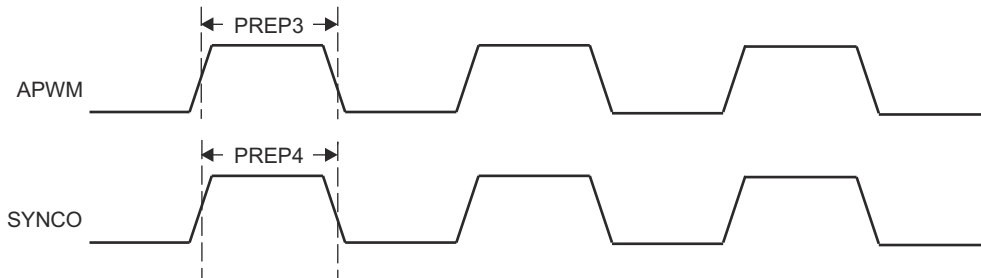

Figure 6-105. PRU_ICSSG ECAP Switching Characteristics

6.11.5.16.6 PRU_ICSSG RGMII, MII_RT, and Switch

For more information, see *Programmable Real-Time Unit Subsystem and Industrial Communication Subsystem - Gigabit (PRU_ICSSG)* section in *Processors and Accelerators* chapter in the device TRM.

6.11.5.16.6.1 PRU_ICSSG MDIO Timing

Table 6-133, Table 6-134, Table 6-135, and Figure 6-106 present timing conditions, timing requirements, and switching characteristics for PRU_ICSSG MDIO.

Table 6-133. PRU_ICSSG MDIO Timing Conditions

| PARAMETER | | MIN | MAX | UNIT |
|--------------------------|-------------------------|-----|-----|------|
| INPUT CONDITIONS | | | | |
| SR _I | Input slew rate | 0.9 | 3.6 | V/ns |
| OUTPUT CONDITIONS | | | | |
| C _L | Output load capacitance | 10 | 470 | pF |

Table 6-134. PRU_ICSSG MDIO Timing Requirements

see Figure 6-106

| NO. | PARAMETER | | MIN | MAX | UNIT |
|-------|----------------------------|--|-----|-----|------|
| MDIO1 | t _{su} (MDIO_MDC) | Setup time, MDIO[x]_MDIO valid before MDIO[x]_MDC high | 90 | | ns |
| MDIO2 | t _h (MDC_MDIO) | Hold time, MDIO[x]_MDIO valid after MDIO[x]_MDC high | 0 | | ns |

Table 6-135. PRU_ICSSG MDIO Switching Characteristics

see Figure 6-106

| NO. | PARAMETER | | MIN | MAX | UNIT |
|-------|---------------------------|---|------|-----|------|
| MDIO3 | t _c (MDC) | Cycle time, MDIO[x]_MDC | 400 | | ns |
| MDIO4 | t _w (MDCH) | Pulse Duration, MDIO[x]_MDC high | 160 | | ns |
| MDIO5 | t _w (MDCL) | Pulse Duration, MDIO[x]_MDC low | 160 | | ns |
| MDIO7 | t _d (MDC_MDIO) | Delay time, MDIO[x]_MDC low to MDIO[x]_MDIO valid | -150 | 150 | ns |

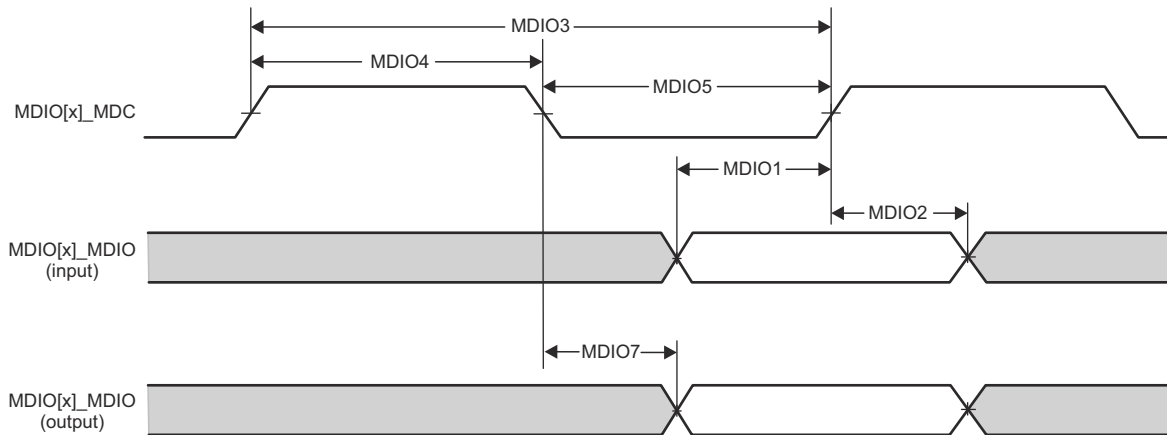

CPSW2G_MDIO_TIMING_01

Figure 6-106. PRU_ICSSG MDIO Timing Requirements and Switching Characteristics

6.11.5.16.6.2 PRU_ICSSG MII Timing

Note

In order to ensure the MII_G_RT I/O timing values published in the device data sheet, the PRU_ICSSG ICSSGn_CORE_CLK (where n = 0 to 1) core clock must be configured for 200MHz, 225MHz, or 250MHz and the TX_CLK_DELAYn (where n = 0 or 1) bit field in the ICSSG_TXCFG0/1 register must be set to 0h (default value).

Table 6-136, Table 6-137, Figure 6-107, Table 6-138, Figure 6-108, Table 6-139, Figure 6-109, Table 6-140, and Figure 6-110 present timing conditions, timing requirements, and switching characteristics for PRU_ICSSG MII.

Table 6-136. PRU_ICSSG MII Timing Conditions

| PARAMETER | | MIN | MAX | UNIT |
|--------------------------|-------------------------|-----|-----|------|
| INPUT CONDITIONS | | | | |
| SR _i | Input slew rate | 0.9 | 3.6 | V/ns |
| OUTPUT CONDITIONS | | | | |
| C _L | Output load capacitance | 2 | 20 | pF |

Table 6-137. PRU_ICSSG MII Timing Requirements – MII[x]_RX_CLK

see Figure 6-107

| NO. | PARAMETER | DESCRIPTION | MODE | MIN | MAX | UNIT |
|-------|--------------------------|------------------------------------|---------|--------|--------|------|
| PMIR1 | t _c (RX_CLK) | Cycle time, MII[x]_RX_CLK | 10Mbps | 399.96 | 400.04 | ns |
| | | | 100Mbps | 39.996 | 40.004 | ns |
| PMIR2 | t _w (RX_CLKH) | Pulse Duration, MII[x]_RX_CLK High | 10Mbps | 140 | 260 | ns |
| | | | 100Mbps | 14 | 26 | ns |
| PMIR3 | t _w (RX_CLKL) | Pulse Duration, MII[x]_RX_CLK Low | 10Mbps | 140 | 260 | ns |
| | | | 100Mbps | 14 | 26 | ns |

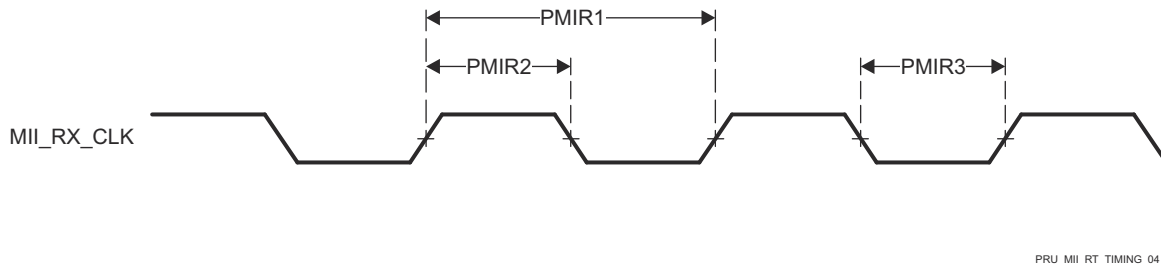

Figure 6-107. PRU_ICSSG MII[x]_RX_CLK Timing

Table 6-138. PRU_ICSSG MII Timing Requirements – MII[x]_RXD[3:0], MII[x]_RX_DV, and MII[x]_RX_ER

see [Figure 6-108](#)

| NO. | PARAMETER | DESCRIPTION | MODE | MIN | MAX | UNIT | |
|-------|--------------------------|--|--|---------|-----|------|----|
| PMIR4 | $t_{su}(RXD-RX_CLK)$ | Setup time, MII[x]_RXD[3:0] valid before MII[x]_RX_CLK | 10Mbps | 8 | | ns | |
| | $t_{su}(RX_DV-RX_CLK)$ | Setup time, MII[x]_RX_DV valid before MII[x]_RX_CLK | | 8 | | ns | |
| | $t_{su}(RX_ER-RX_CLK)$ | Setup time, MII[x]_RX_ER valid before MII[x]_RX_CLK | | 8 | | ns | |
| | PMIR5 | $t_{su}(RXD-RX_CLK)$ | Setup time, MII[x]_RXD[3:0] valid before MII[x]_RX_CLK | 100Mbps | 8 | | ns |
| | | $t_{su}(RX_DV-RX_CLK)$ | Setup time, MII[x]_RX_DV valid before MII[x]_RX_CLK | | 8 | | ns |
| | | $t_{su}(RX_ER-RX_CLK)$ | Setup time, MII[x]_RX_ER valid before MII[x]_RX_CLK | | 8 | | ns |
| PMIR5 | $t_h(RX_CLK-RXD)$ | Hold time, MII[x]_RXD[3:0] valid after MII[x]_RX_CLK | 10Mbps | 8 | | ns | |
| | $t_h(RX_CLK-RX_DV)$ | Hold time, MII[x]_RX_DV valid after MII[x]_RX_CLK | | 8 | | ns | |
| | $t_h(RX_CLK-RX_ER)$ | Hold time, MII[x]_RX_ER valid after MII[x]_RX_CLK | | 8 | | ns | |
| | PMIR5 | $t_h(RX_CLK-RXD)$ | Hold time, MII[x]_RXD[3:0] valid after MII[x]_RX_CLK | 100Mbps | 8 | | ns |
| | | $t_h(RX_CLK-RX_DV)$ | Hold time, MII[x]_RX_DV valid after MII[x]_RX_CLK | | 8 | | ns |
| | | $t_h(RX_CLK-RX_ER)$ | Hold time, MII[x]_RX_ER valid after MII[x]_RX_CLK | | 8 | | ns |

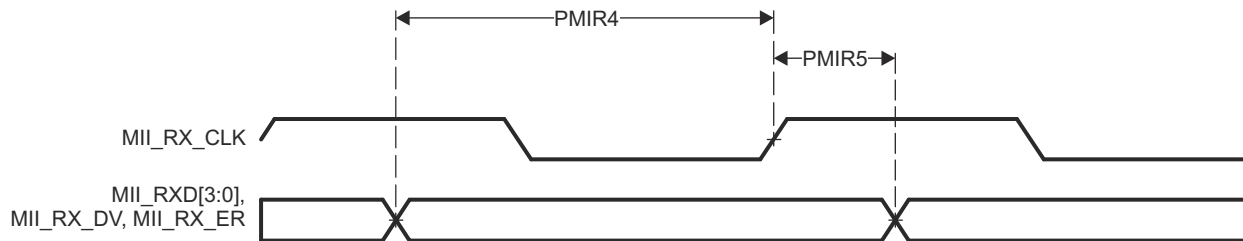

Figure 6-108. PRU_ICSSG MII[x]_RXD[3:0], MII[x]_RX_DV, and MII[x]_RX_ER Timing

Table 6-139. PRU_ICSSG MII Timing Requirements – MII[x]_TX_CLK

see [Figure 6-109](#)

| NO. | PARAMETER | DESCRIPTION | MODE | MIN | MAX | UNIT |
|-------|-----------------|------------------------------------|---------|--------|--------|------|
| PMIT1 | $t_c(TX_CLK)$ | Cycle time, MII[x]_TX_CLK | 10Mbps | 399.96 | 400.04 | ns |
| | | | 100Mbps | 39.996 | 40.004 | ns |
| PMIT2 | $t_w(TX_CLKH)$ | Pulse Duration, MII[x]_TX_CLK High | 10Mbps | 140 | 260 | ns |
| | | | 100Mbps | 14 | 26 | ns |
| PMIT3 | $t_w(TX_CLKL)$ | Pulse Duration, MII[x]_TX_CLK Low | 10Mbps | 140 | 260 | ns |
| | | | 100Mbps | 14 | 26 | ns |

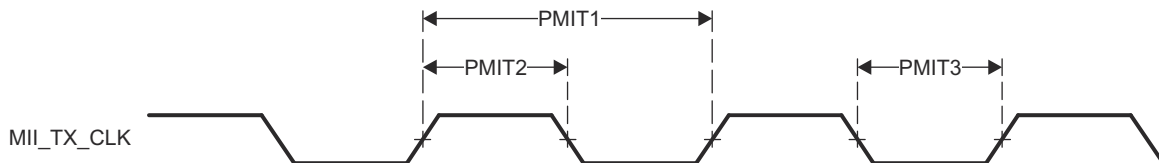

Figure 6-109. PRU_ICSSG MII[x]_TX_CLK Timing

Table 6-140. PRU_ICSSG MII Switching Characteristics – MII[x]_TXD[3:0] and MII[x]_TX_EN

see [Figure 6-110](#)

| NO. | PARAMETER | DESCRIPTION | MODE | MIN | MAX | UNIT |
|-------|------------------------------|---|---------|-----|-----|------|
| PMIT4 | $t_d(\text{TX_CLK-TXD})$ | Delay time, MII[x]_TX_CLK High to MII[x]_TXD[3:0] valid | 10Mbps | 0 | 25 | ns |
| | $t_d(\text{TX_CLK-TX_EN})$ | Delay time, MII[x]_TX_CLK to MII[x]_TX_EN valid | | 0 | 25 | ns |
| | $t_d(\text{TX_CLK-TXD})$ | Delay time, MII[x]_TX_CLK High to MII[x]_TXD[3:0] valid | 100Mbps | 0 | 25 | ns |
| | $t_d(\text{TX_CLK-TX_EN})$ | Delay time, MII[x]_TX_CLK to MII[x]_TX_EN valid | | 0 | 25 | ns |

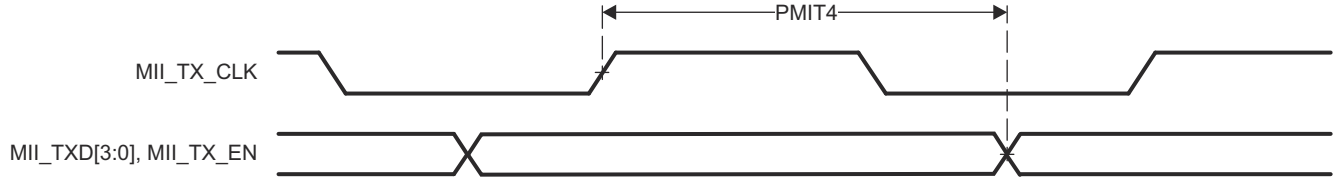

Figure 6-110. PRU_ICSSG MII[x]_TXD[3:0], MII[x]_TX_EN Timing

6.11.5.16.6.3 PRU_ICSSG RGMII Timing

Table 6-141, Table 6-142, Table 6-143, Figure 6-111, Table 6-144, Table 6-145, and Figure 6-112 present timing conditions, timing requirements, and switching characteristics for PRU_ICSSG RGMII.

Table 6-141. PRU_ICSSG RGMII Timing Conditions

| PARAMETER | | MIN | MAX | UNIT | |
|---------------------------------------|--|---|------|------|------|
| INPUT CONDITIONS | | | | | |
| SR _i | Input slew rate | VDD ⁽¹⁾ = 1.8V | 1.44 | 5 | V/ns |
| | | VDD ⁽¹⁾ = 3.3V | 2.65 | 5 | V/ns |
| OUTPUT CONDITIONS | | | | | |
| C _L | Output load capacitance | 2 | 20 | pF | |
| PCB CONNECTIVITY REQUIREMENTS | | | | | |
| t _d (Trace Mismatch Delay) | Propagation delay mismatch across all traces | RGMII[x]_RXC, RGMII[x]_RD[3:0], RGMII[x]_RX_CTL | | 50 | ps |
| | | RGMII[x]_TXC, RGMII[x]_TD[3:0], RGMII[x]_TX_CTL | | 50 | ps |

- (1) VDD stands for corresponding power supply. For more information on the power supply name and the corresponding ball(s), see POWER column of the *Pin Attributes* table.

Table 6-142. PRU_ICSSG RGMII Timing Requirements – RGMII[x]_RXC

see Figure 6-111

| NO. | PARAMETER | DESCRIPTION | MODE | MIN | MAX | UNIT |
|--------|---------------|-----------------------------------|----------|-----|-----|------|
| RGMII1 | $t_{c(RXC)}$ | Cycle time, RGMII[x]_RXC | 10Mbps | 360 | 440 | ns |
| | | | 100Mbps | 36 | 44 | ns |
| | | | 1000Mbps | 7.2 | 8.8 | ns |
| RGMII2 | $t_{w(RXCH)}$ | Pulse duration, RGMII[x]_RXC high | 10Mbps | 160 | 240 | ns |
| | | | 100Mbps | 16 | 24 | ns |
| | | | 1000Mbps | 3.6 | 4.4 | ns |
| RGMII3 | $t_{w(RXCL)}$ | Pulse duration, RGMII[x]_RXC low | 10Mbps | 160 | 240 | ns |
| | | | 100Mbps | 16 | 24 | ns |
| | | | 1000Mbps | 3.6 | 4.4 | ns |

Table 6-143. PRU_ICSSG RGMII Timing Requirements – RGMII[x]_RD[3:0] and RGMII[x]_RX_CTL

see Figure 6-111

| NO. | PARAMETER | DESCRIPTION | MODE | MIN | MAX | UNIT |
|--------|-----------------------|--|----------|-----|-----|------|
| RGMII4 | $t_{su(RD-RXC)}$ | Setup time, RGMII[x]_RD[3:0] valid before RXC high/low | 10Mbps | 1 | | ns |
| | | | 100Mbps | 1 | | ns |
| | | | 1000Mbps | 1 | | ns |
| | $t_{su(RX_CTL-RXC)}$ | Setup time, RGMII[x]_RX_CTL valid before RGMII[x]_RXC high/low | 10Mbps | 1 | | ns |
| | | | 100Mbps | 1 | | ns |
| | | | 1000Mbps | 1 | | ns |
| RGMII5 | $t_h(RXC-RD)$ | Hold time, RGMII[x]_RD[3:0] valid after RGMII[x]_RXC high/low | 10Mbps | 1 | | ns |
| | | | 100Mbps | 1 | | ns |
| | | | 1000Mbps | 1 | | ns |
| | $t_h(RXC-RX_CTL)$ | Hold time, RGMII[x]_RX_CTL valid after RGMII[x]_RXC high/low | 10Mbps | 1 | | ns |
| | | | 100Mbps | 1 | | ns |
| | | | 1000Mbps | 1 | | ns |

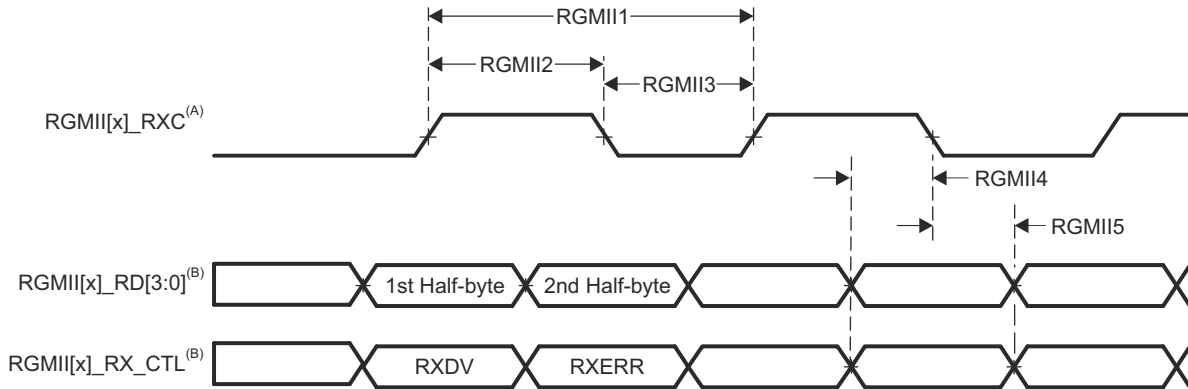

- A. RGMII[x]_RXC must be externally delayed relative to the data and control pins.
- B. Data and control information is received using both edges of the clocks. RGMII[x]_RD[3:0] carries data bits 3-0 on the rising edge of RGMII[x]_RXC and data bits 7-4 on the falling edge of RGMII[x]_RXC. Similarly, RGMII[x]_RX_CTL carries RXDV on rising edge of RGMII[x]_RXC and RXERR on falling edge of RGMII[x]_RXC.

Figure 6-111. PRU_ICSSG RGMII[x]_RXC, RGMII[x]_RD[3:0], RGMII[x]_RX_CTL Timing Requirements - RGMII Mode

Table 6-144. PRU_ICSSG RGMII Switching Characteristics – RGMII[x]_TXC

see Figure 6-112

| NO. | PARAMETER | DESCRIPTION | MODE | MIN | MAX | UNIT |
|--------|---------------|-----------------------------------|----------|-----|-----|------|
| RGMII6 | $t_{c(TXC)}$ | Cycle time, RGMII[x]_TXC | 10Mbps | 360 | 440 | ns |
| | | | 100Mbps | 36 | 44 | ns |
| | | | 1000Mbps | 7.2 | 8.8 | ns |
| RGMII7 | $t_{w(TXCH)}$ | Pulse duration, RGMII[x]_TXC high | 10Mbps | 160 | 240 | ns |
| | | | 100Mbps | 16 | 24 | ns |
| | | | 1000Mbps | 3.6 | 4.4 | ns |
| RGMII8 | $t_{w(TXCL)}$ | Pulse duration, RGMII[x]_TXC low | 10Mbps | 160 | 240 | ns |
| | | | 100Mbps | 16 | 24 | ns |
| | | | 1000Mbps | 3.6 | 4.4 | ns |

Table 6-145. PRU_ICSSG RGMII Switching Characteristics – RGMII[x]_TD[3:0] and RGMII[x]_TX_CTL

see Figure 6-112

| NO. | PARAMETER | DESCRIPTION | MODE | MIN | MAX | UNIT |
|---------|-----------------------|---|----------|-----|-----|------|
| RGMII9 | $t_{osu(TD-TXC)}$ | Output setup time, RGMII[x]_TD[3:0] valid to RGMII[x]_TXC high/low | 10Mbps | 1.2 | | ns |
| | | | 100Mbps | 1.2 | | ns |
| | | | 1000Mbps | 1.2 | | ns |
| | $t_{osu(TX_CTL-TXC)}$ | Output setup time, RGMII[x]_TX_CTL valid to RGMII[x]_TXC high/low | 10Mbps | 1.2 | | ns |
| | | | 100Mbps | 1.2 | | ns |
| | | | 1000Mbps | 1.2 | | ns |
| RGMII10 | $t_{oh(TXC-TD)}$ | Output setup time, RGMII[x]_TD[3:0] valid after RGMII[x]_TXC high/low | 10Mbps | 1.2 | | ns |
| | | | 100Mbps | 1.2 | | ns |
| | | | 1000Mbps | 1.2 | | ns |
| | $t_{oh(TXC-TX_CTL)}$ | Output setup time, RGMII[x]_TX_CTL valid after RGMII[x]_TXC high/low | 10Mbps | 1.2 | | ns |
| | | | 100Mbps | 1.2 | | ns |
| | | | 1000Mbps | 1.2 | | ns |

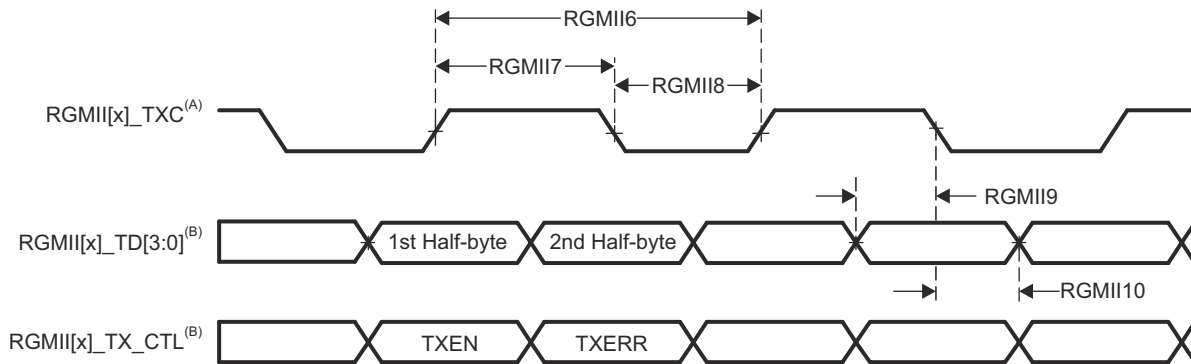

- A. TXC is delayed internally before being driven to the RGMII[x]_TXC pin. This internal delay is always enabled.
- B. Data and control information is received using both edges of the clocks. RGMII[x]_TD[3:0] carries data bits 3-0 on the rising edge of RGMII[x]_TXC and data bits 7-4 on the falling edge of RGMII[x]_TXC. Similarly, RGMII[x]_TX_CTL carries TXEN on rising edge of RGMII[x]_TXC and TXERR on falling edge of RGMII[x]_TXC.

Figure 6-112. PRU_ICSSG RGMII[x]_TXC, RGMII[x]_TD[3:0], and RGMII[x]_TX_CTL Switching Characteristics - RGMII Mode

6.11.5.17 Timers

For more details about features and additional description information on the device Timers, see the corresponding subsections within *Signal Descriptions* and *Detailed Description* sections.

Table 6-146. Timer Timing Conditions

| PARAMETER | | MIN | MAX | UNIT |
|--------------------------|-------------------------|-----|-----|------|
| INPUT CONDITIONS | | | | |
| SR _I | Input slew rate | 0.5 | 5 | V/ns |
| OUTPUT CONDITIONS | | | | |
| C _L | Output load capacitance | 2 | 10 | pF |

Table 6-147. Timer Input Timing Requirements

see [Figure 6-113](#)

| NO. | PARAMETER | DESCRIPTION | MODE | MIN | MAX | UNIT |
|-----|-----------------------|----------------------|---------|-----------------------|-----|------|
| T1 | t _{w(TINPH)} | Pulse duration, high | CAPTURE | 2 + 4P ⁽¹⁾ | | ns |
| T2 | t _{w(TINPL)} | Pulse duration, low | CAPTURE | 2 + 4P ⁽¹⁾ | | ns |

(1) P = functional clock period in ns.

Table 6-148. Timer Output Switching Characteristics

see [Figure 6-113](#)

| NO. | PARAMETER | DESCRIPTION | MODE | MIN | MAX | UNIT |
|-----|-----------------------|----------------------|------|------------------------|-----|------|
| T3 | t _{w(TOUTH)} | Pulse duration, high | PWM | -2 + 4P ⁽¹⁾ | | ns |
| T4 | t _{w(TOURL)} | Pulse duration, low | PWM | -2 + 4P ⁽¹⁾ | | ns |

(1) P = functional clock period in ns.

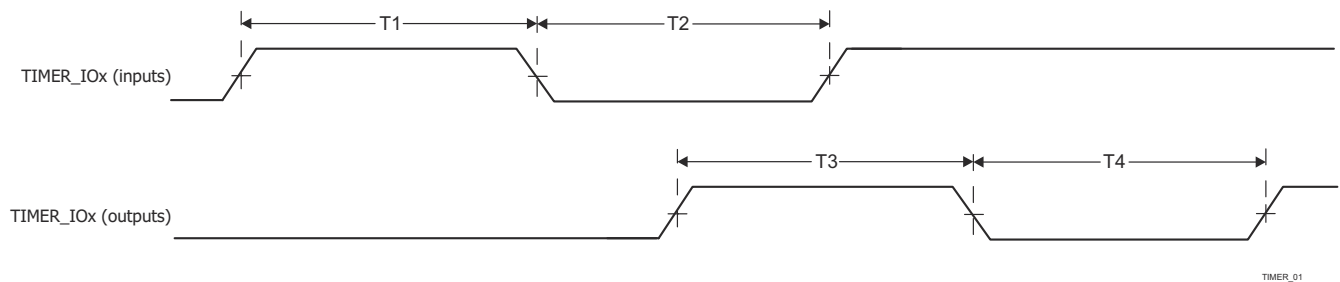

Figure 6-113. Timer Timing Requirements and Switching Characteristics

For more information, see *Timers* section in *Peripherals* chapter in the device TRM.

6.11.5.18 UART

For more details about features and additional description information on the device Universal Asynchronous Receiver Transmitter, see the corresponding subsections within *Signal Descriptions* and *Detailed Description* sections.

Table 6-149. UART Timing Conditions

| PARAMETER | | MIN | MAX | UNIT |
|--------------------------|-------------------------|-----|-------------------|------|
| INPUT CONDITIONS | | | | |
| SR _I | Input slew rate | 0.5 | 5 | V/ns |
| OUTPUT CONDITIONS | | | | |
| C _L | Output load capacitance | 1 | 30 ⁽¹⁾ | pF |

(1) This value represents an absolute maximum load capacitance. As the UART baud rate increases, it may be necessary to reduce the load capacitance to a value less than this maximum limit to provide enough timing margin for the attached device. The output rise/fall times increase as capacitive load increases, which decreases the time data is valid for the receiver of the attached devices. Therefore, it is important to understand the minimum data valid time required by the attached device at the operating baud rate. Then use the device IBIS models to verify the actual load capacitance on the UART signals does not increase the rise/fall times beyond the point where the minimum data valid time of the attached device is violated.

Table 6-150. UART Timing Requirements

see [Figure 6-114](#)

| NO. | PARAMETER | DESCRIPTION | MIN | MAX | UNIT |
|-----|----------------------|---|-----------------------------|-----------------------------|------|
| 1 | t _{w(RXD)} | Pulse width, receive data bit high or low | 0.95U ⁽¹⁾ (2) | 1.05U ⁽¹⁾ (2) | ns |
| 2 | t _{w(RXDS)} | Pulse width, receive start bit low | 0.95U ⁽¹⁾ (2) | | ns |

(1) U = UART baud time in ns = 1/programmed baud rate.

(2) This value defines the data valid time, where the input voltage is required to be above V_{IH} or below V_{IL}.

Table 6-151. UART Switching Characteristics

see [Figure 6-114](#)

| NO. | PARAMETER | DESCRIPTION | MIN | MAX | UNIT |
|-----|----------------------|--|------------------------|------------------------|------|
| | f _(baud) | Programmable baud rate for Main Domain UARTs | | 12 | Mbps |
| | | Programmable baud rate for MCU Domain UARTs | | 3.7 | Mbps |
| 3 | t _{w(TXD)} | Pulse width, transmit data bit high or low | U ⁽¹⁾ - 2.2 | U ⁽¹⁾ + 2.2 | ns |
| 4 | t _{w(TXDS)} | Pulse width, transmit start bit low | U ⁽¹⁾ - 2.2 | | ns |

(1) U = UART baud time in ns = 1/programmed baud rate.

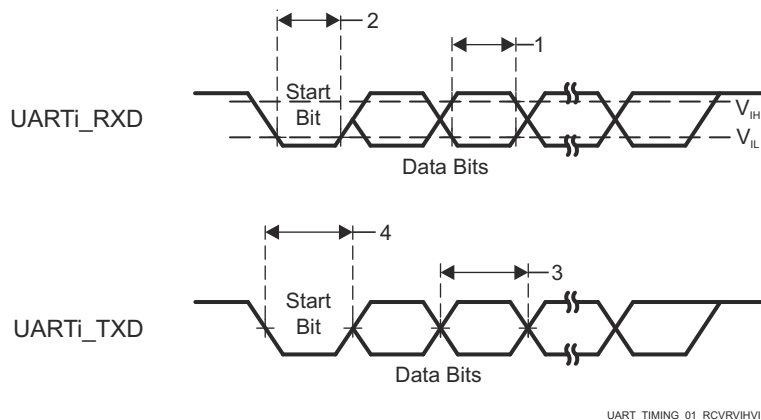

Figure 6-114. UART Timing Requirements and Switching Characteristics

For more information, see *Universal Asynchronous Receiver/Transmitter (UART)* section in *Peripherals* chapter in the device TRM.

6.11.5.19 USB

The USB 2.0 subsystem is compliant with the Universal Serial Bus (USB) Specification, revision 2.0. Refer to the specification for timing details.

The USB 3.1 GEN1 subsystem is compliant with the Universal Serial Bus (USB) 3.1 Specification, revision 1.0. Refer to the specification for timing details.

For more details about features and additional description information on the device Universal Serial Bus Subsystem (USB), see the *SERDES0 Signal Descriptions* and the corresponding subsection within *Detailed Description*.

6.11.6 Emulation and Debug

For more details about features and additional description information on the device Trace and JTAG interfaces, see the corresponding subsections within *Signal Descriptions* and *Detailed Description* sections.

6.11.6.1 Trace

Table 6-152. Trace Timing Conditions

| PARAMETER | | MIN | MAX | UNIT |
|--------------------------------------|--|----------------|-----|------|
| OUTPUT CONDITIONS | | | | |
| C_L | Output load capacitance | 2 | 5 | pF |
| PCB CONNECTIVITY REQUIREMENTS | | | | |
| t_d (Trace Mismatch) | Propagation delay mismatch across all traces | VDDSHV3 = 1.8V | 200 | ps |
| | | VDDSHV3 = 3.3V | 100 | ps |

Table 6-153. Trace Switching Characteristics

| NO. | PARAMETER | | MIN | MAX | UNIT |
|------------------|-------------------------------|--|------|-----|------|
| 1.8V Mode | | | | | |
| DBTR1 | t_c (TRC_CLK) | Cycle time, TRC_CLK | 6.50 | | ns |
| DBTR2 | t_w (TRC_CLKH) | Pulse width, TRC_CLK high | 2.50 | | ns |
| DBTR3 | t_w (TRC_CLKL) | Pulse width, TRC_CLK low | 2.50 | | ns |
| DBTR4 | t_{osu} (TRC_DATAV-TRC_CLK) | Output setup time, TRC_DATA valid to TRC_CLK edge | 0.81 | | ns |
| DBTR5 | t_{oh} (TRC_CLK-TRC_DATAI) | Output hold time, TRC_CLK edge to TRC_DATA invalid | 0.81 | | ns |
| DBTR6 | t_{osu} (TRC_CTLV-TRC_CLK) | Output setup time, TRC_CTL valid to TRC_CLK edge | 0.81 | | ns |
| DBTR7 | t_{oh} (TRC_CLK-TRC_CTLI) | Output hold time, TRC_CLK edge to TRC_CTL invalid | 0.81 | | ns |
| 3.3V Mode | | | | | |
| DBTR1 | t_c (TRC_CLK) | Cycle time, TRC_CLK | 8.67 | | ns |
| DBTR2 | t_w (TRC_CLKH) | Pulse width, TRC_CLK high | 3.58 | | ns |
| DBTR3 | t_w (TRC_CLKL) | Pulse width, TRC_CLK low | 3.58 | | ns |
| DBTR4 | t_{osu} (TRC_DATAV-TRC_CLK) | Output setup time, TRC_DATA valid to TRC_CLK edge | 1.08 | | ns |
| DBTR5 | t_{oh} (TRC_CLK-TRC_DATAI) | Output hold time, TRC_CLK edge to TRC_DATA invalid | 1.08 | | ns |
| DBTR6 | t_{osu} (TRC_CTLV-TRC_CLK) | Output setup time, TRC_CTL valid to TRC_CLK edge | 1.08 | | ns |
| DBTR7 | t_{oh} (TRC_CLK-TRC_CTLI) | Output hold time, TRC_CLK edge to TRC_CTL invalid | 1.08 | | ns |

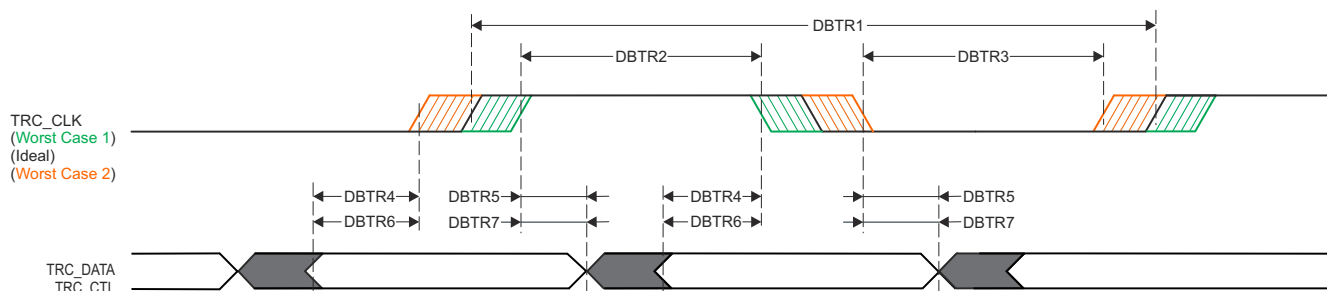

SPRSP08_Debug_01

Figure 6-115. Trace Switching Characteristics

6.11.6.2 JTAG

Table 6-154. JTAG Timing Conditions

| PARAMETER | | MIN | MAX | UNIT |
|---------------------------------------|--|------|---------------------|------|
| INPUT CONDITIONS | | | | |
| SR _I | Input slew rate | 0.5 | 2.0 | V/ns |
| OUTPUT CONDITIONS | | | | |
| C _L | Output load capacitance | 5 | 15 | pF |
| PCB CONNECTIVITY REQUIREMENTS | | | | |
| t _d (Trace Delay) | Propagation delay of each trace | 83.5 | 1000 ⁽¹⁾ | ps |
| t _d (Trace Mismatch Delay) | Propagation delay mismatch across all traces | | 100 | ps |

(1) Maximum propagation delay associated with the JTAG signal traces has a significant impact on maximum TCK operating frequency. It may be possible to increase the trace delay beyond this value, but the operating frequency of TCK must be reduced to account for the additional trace delay.

Table 6-155. JTAG Timing Requirements

see Figure 6-116

| NO. | PARAMETER | DESCRIPTION | MIN | MAX | UNIT |
|-----|---------------------------|--|---------------------|-----|------|
| J1 | t _c (TCK) | Cycle time minimum, TCK | 45.5 ⁽¹⁾ | | ns |
| J2 | t _w (TCKH) | Pulse width minimum, TCK high | 0.4P ⁽²⁾ | | ns |
| J3 | t _w (TCKL) | Pulse width minimum, TCK low | 0.4P ⁽²⁾ | | ns |
| J4 | t _{su} (TDI-TCK) | Input setup time minimum, TDI valid to TCK high | 4 | | ns |
| | t _{su} (TMS-TCK) | Input setup time minimum, TMS valid to TCK high | 4 | | ns |
| J5 | t _h (TCK-TDI) | Input hold time minimum, TDI valid from TCK high | 2 | | ns |
| | t _h (TCK-TMS) | Input hold time minimum, TMS valid from TCK high | 2 | | ns |

(1) The maximum TCK operating frequency assumes the following timing requirements and switching characteristics for the attached debugger. The operating frequency of TCK must be reduced to provide appropriate timing margin if the debugger exceeds any of these assumptions.

- Minimum TDO setup time of 2.2ns relative to the rising edge of TCK
- TDI and TMS output delay in the range of -16.1ns to 14.1ns relative to the falling edge of TCK

(2) P = TCK cycle time in ns

Table 6-156. JTAG Switching Characteristics

see Figure 6-116

| NO. | PARAMETER | DESCRIPTION | MIN | MAX | UNIT |
|-----|----------------------------|--|-----|-----|------|
| J6 | t _d (TCKL-TDOI) | Delay time minimum, TCK low to TDO invalid | 0 | | ns |
| J7 | t _d (TCKL-TDOV) | Delay time maximum, TCK low to TDO valid | | 14 | ns |

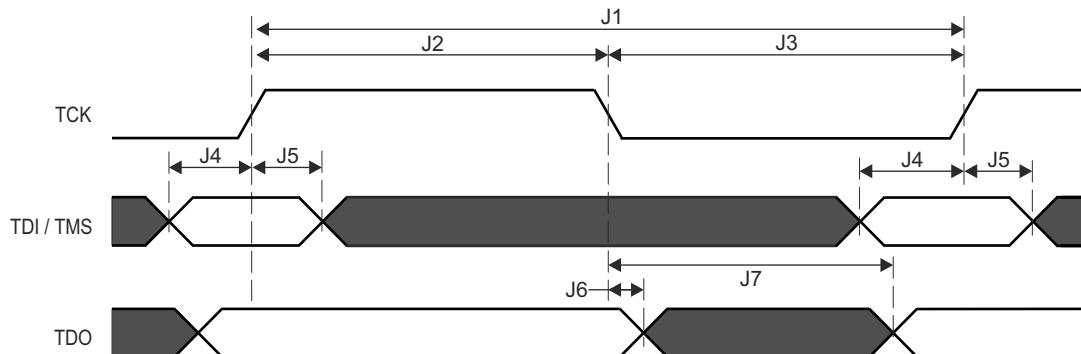

Figure 6-116. JTAG Timing Requirements and Switching Characteristics

7 Detailed Description

7.1 Overview

AM243x is an extension of the Sitara™ industrial-grade family of heterogeneous Arm processors. AM243x is built for industrial applications, such as motor drives and programmable logic controllers (PLCs), which require a unique combination of real-time processing and communications with applications processing. AM243x combines two instances of Sitara's gigabit TSN-enabled PRU-ICSSG, up to four Cortex-R5F MCUs, and a Cortex-M4F MCU domain.

AM243x is architected to provide real-time performance through the high-performance R5Fs, Tightly-Coupled Memory banks, configurable SRAM partitioning, and low-latency paths to and from peripherals for rapid data movement in and out of the SoC. This deterministic architecture allows for AM243x to handle the tight control loops found in servo drives, while the peripherals like FSI, GPMC, PWMs, sigma delta decimation filters, and absolute encoder interfaces help enable a number of different architectures found in these systems.

The PRU_ICSSG in AM243x provides the flexible industrial communications capability necessary to run gigabit TSN, EtherCAT, PROFINET, EtherNet/IP, and various other protocols. In addition, the PRU_ICSSG also enables additional interfaces in the SoC including sigma delta decimation filter modules and absolute encoder interfaces.

Functional safety features can be enabled through the MCU domain with an integrated Cortex-M4F and dedicated peripheral set which can all be shared or isolated from the rest of the SoC. AM243x also supports secure boot.

Note

For more information on features, subsystems, and architecture of superset device System on Chip (SoC), see the device TRM.

7.2 Processor Subsystems

7.2.1 Arm Cortex-R5F Subsystem (R5FSS)

The R5FSS is a dual-core implementation of the Arm® Cortex®-R5F processor configured for dual/single-core operation. It also includes accompanying memories (L1 caches and tightly-coupled memories), standard Arm® CoreSight™ debug and trace architecture, integrated Vectored Interrupt Manager (VIM), ECC Aggregators, and various wrappers for protocol conversion and address translation for easy integration into the SoC.

Note

The Cortex®-R5F processor is a Cortex-R5 processor that includes the optional Floating Point Unit (FPU) extension.

For more information, see *Dual-R5F Subsystem (R5FSS)* section in *Processors and Accelerators* chapter in the device TRM.

7.2.2 Arm Cortex-M4F (M4FSS)

The M4FSS module on the AM243x device provides a safety channel (secondary channel - working in conjunction with an external microcontroller)- or- a general purpose MCU.

The M4FSS module supports the following features:

- Cortex M4F With MPU
- ARMv7-M architecture
- Support for Nested Vectored Interrupt Controller (NVIC) with 64 inputs
- Ability to executed code from internal or external memories
- 192 KB of SRAM (I-Code)
- 64 KB of SRAM (D-Code)
- External access to internal memories if allowed
- Debug Support Including:
 - DAP based Debug to the CPU Core
 - Full Debug Features of CPU Core are enabled
 - Standard ITM trace
 - CTM Cross Trigger
 - ETM Trace Support
- Fault Detection and Correction
 - SECEDED ECC protection on I-CODE
 - SECEDED ECC protection on D-CODE
 - Fault Error Interrupt Output

For more information, see *Arm Cortex M4F Subsystem (M4FSS)* section in *Processors and Accelerators* chapter in the device TRM.

7.3 Accelerators and Coprocessors

7.3.1 Programmable Real-Time Unit Subsystem and Industrial Communication Subsystem (PRU_ICSSG)

The PRU_ICSSG module supports the following main features:

- 3x PRUs
 - General-Purpose PRU (PRU)
 - Real-Time PRU(RTU_PRU)
 - Transmit PRU (TX_PRU)
- 2x Ethernet MII_G_RT configurable connection to PRUs
 - Up to 2x RGMII ports
 - Up to 2x MII ports
 - RX Classifier
- 2x Industrial Ethernet Peripheral (IEP) to manage and generate industrial Ethernet functions
- 2x Industrial Ethernet 64-bit timers, each with 10 capture and 16 compare events, along with slow and fast compensation.
- 1x MDIO
- 1x UART, with a dedicated 192MHz clock input
- Supports up to 4 sets of 3-phased motor control, with 12 primary and 12 complimentary programmable PWM outputs.
- Supports up to 9 safety events with optional external trip I/O per PWM set with hardware glitch filter.
- 1x Enhanced Capture Module (ECAP)
- 1x Interrupt Controller (INTC)
 - 160 input events supported – 96 external, 64 internal
- Flexible power management support
- Integrated switched central resource with programmable priority
- All memories support ECC

For more information, see *Programmable Real-Time Unit Subsystem and Industrial Communication Subsystem - Gigabit (PRU_ICSSG)* section in *Processors and Accelerators* chapter in the device TRM.

7.4 Other Subsystems

7.4.1 PDMA Controller

The Peripheral DMA is a simple DMA which has been architected to specifically meet the data transfer needs of peripherals, which perform data transfers using memory mapped registers accessed via a standard non-coherent bus fabric. The PDMA module is intended to be located close to one or more peripherals which require an external DMA for data movement and is architected to reduce cost by using VBUSP interfaces and supporting only statically configured Transfer Request (TR) operations.

The PDMA is only responsible for performing the data movement transactions which interact with the peripherals themselves. Data which is read from a given peripheral is packed by a PDMA source channel into a PSI-L data stream which is then sent to a remote peer UDMA-P destination channel which then performs the movement of the data into memory. Likewise, a remote UDMA-P source channel fetches data from memory and transfers it to a peer PDMA destination channel over PSI-L which then performs the writes to the peripheral.

The PDMA architecture is intentionally heterogeneous (UDMA-P + PDMA) to right size the data transfer complexity at each point in the system to match the requirements of whatever is being transferred to or from. Peripherals are typically FIFO based and do not require multi-dimensional transfers beyond their FIFO dimensioning requirements, so the PDMA transfer engines are kept simple with only a few dimensions (typically for sample size and FIFO depth), hardcoded address maps, and simple triggering capabilities.

Multiple source and destination channels are provided within the PDMA which allow multiple simultaneous transfer operations to be ongoing. The DMA controller maintains state information for each of the channels and employs round-robin scheduling between channels in order to share the underlying DMA hardware.

There are five PDMA modules in the device.

For more information, see *PDMA Controller* section in *DMA Controllers* chapter in the device TRM.

7.4.2 Peripherals

7.4.2.1 ADC

The analog-to-digital converter (ADC) module is a single-channel general purpose analog-to-digital converter with an 8-input analog multiplexer, which supports 12-bit conversion samples from an analog front end (AFE).

There is one ADC module in the device.

Note

The AM243x_ALX package only supports 10-bits of data from the 12-bit conversion.

For more information, see *Analog-to-Digital Converter (ADC)* section in *Peripherals* chapter in the device TRM.

7.4.2.2 DCC

The Dual Clock Comparator (DCC) is used to determine the accuracy of a clock signal during the time execution of an application. Specifically, the DCC is designed to detect drifts from the expected clock frequency. The desired accuracy can be programmed based on calculation for each application. The DCC measures the frequency of a selectable clock source using another input clock as a reference.

The device has seven instances of DCC modules.

For more information, see *Dual Clock Comparator (DCC)* section in *Peripherals* chapter in the device TRM.

7.4.2.3 Dual Data Rate (DDR) External Memory Interface (DDRSS)

Integrated in MAIN domain: one instance of DDR Subsystem (DDRSS) is used as an interface to external RAM devices which can be utilized for storing program or data. DDRSS provides the following main features:

- Support of DDR4 / LPDDR4 memory types
- 16-bit memory bus interface with in-line ECC
- System bus interface: little Endian only with 128-bit data width
- Configuration bus Interface: little Endian only with 32-bit data width
- Support of dual rank configuration
- Support of automatic idle power saving mode when no or low activity is detected
- Class of Service (CoS) - three latency classes supported
- Prioritized refresh scheduling
- Statistical counters for performance management

For more information, see *DDR Subsystem (DDRSS)* section in *Peripherals* chapter in the device TRM.

7.4.2.4 ECAP

This section describes the Enhanced Capture (ECAP) module for the device.

For more information, see *Enhanced Capture (ECAP) Module* section in *Peripherals* chapter in the device TRM.

7.4.2.5 EPWM

An effective PWM peripheral must be able to generate complex pulse width waveforms with minimal CPU overhead or intervention. It needs to be highly programmable and very flexible while being easy to understand and use. The EPWM unit described here addresses these requirements by allocating all needed timing and control resources on a per PWM channel basis. Cross coupling or sharing of resources has been avoided; instead, the EPWM is built up from smaller single channel modules with separate resources and that can operate together as required to form a system. This modular approach results in an orthogonal architecture and provides a more transparent view of the peripheral structure, helping users to understand its operation quickly.

In the further description the letter x within a signal or module name is used to indicate a generic EPWM instance on a device. For example, output signals EPWMxA and EPWMxB refer to the output signals from the EPWM_x

instance. Thus, EPWM1A and EPWM1B belong to EPWM1, EPWM2A and EPWM2B belong to EPWM2, and so forth.

Additionally, the EPWM integration allows this synchronization scheme to be extended to the capture peripheral modules (ECAP). The number of modules is device-dependent and based on target application needs. Modules can also operate stand-alone.

The device has six instances of EPWM modules.

For more information, see *Enhanced Pulse Width Modulation (EPWM) Module* section in *Peripherals* chapter in the device TRM.

7.4.2.6 ELM

The Error Location Module (ELM) is used with the GPMC. Syndrome polynomials generated on-the-fly when reading a NAND flash page and stored in GPMC registers are passed to the ELM. A host processor can then correct the data block by flipping the bits to which the ELM error-location outputs point.

When reading from NAND flash memories, some level of error-correction is required. In the case of NAND modules with no internal correction capability, sometimes referred to as *bare NANDs*, the correction process is delegated to the memory controller. ELM can be also used to support parallel NOR flash or NAND flash.

The General-Purpose Memory Controller (GPMC) probes data read from an external NAND flash and uses this to compute checksum-like information, called syndrome polynomials, on a per-block basis. Each syndrome polynomial gives a status of the read operations for a full block, including 512 bytes of data, parity bits, and an optional spare-area data field, with a maximum block size of 1023 bytes. Computation is based on a Bose-Chaudhuri-Hocquenghem (BCH) algorithm. The ELM extracts error addresses from these syndrome polynomials.

For more information, see *Error Location Module (ELM)* section in *Peripherals* chapter in the device TRM.

7.4.2.7 ESM

The Error Signaling Module (ESM) aggregates safety-related events and/or errors from throughout the device into one location. The module can signal both low and high priority interrupts to a processor to deal with a safety event and/or manipulate an I/O error pin to signal external hardware that an error has occurred. This allows an external controller to reset the device or keep the system in safe, known state.

For more information, see *Error Signaling Module (ESM)* section in *Peripherals* chapter in the device TRM.

7.4.2.8 GPIO

The general-purpose input/output (GPIO) peripheral provides dedicated general-purpose pins that can be configured as either inputs or outputs. When configured as an output, user can write to an internal register to control the state driven on the output pin. When configured as an input, user can obtain the state of the input by reading the state of an internal register.

In addition, the GPIO peripheral can produce host CPU interrupts and DMA synchronization events in different interrupt/event generation modes.

For more information, see *General-Purpose Interface (GPIO)* section in *Peripherals* chapter in the device TRM.

7.4.2.9 EQEP

The Enhanced Quadrature Encoder Pulse (EQEP) peripheral is used for direct interface with a linear or rotary incremental encoder to get position, direction and speed information from a rotating machine for use in high performance motion and position control system. The disk of an incremental encoder is patterned with a single track of slots patterns. These slots create an alternating pattern of dark and light lines. The disk count is defined as the number of dark/light line pairs that occur per revolution (lines per revolution). As a rule, a second track is added to generate a signal that occurs once per revolution (index signal: QEPI), which can be used to indicate an absolute position. Encoder manufacturers identify the index pulse using different terms such as index, marker, home position and zero reference.

To derive direction information, the lines on the disk are read out by two different photo-elements that "look" at the disk pattern with a mechanical shift of 1/4 the pitch of a line pair between them. This shift is realized with a reticle or mask that restricts the view of the photo-element to the desired part of the disk lines. As the disk rotates, the two photo-elements generate signals that are shifted 90 degrees out of phase from each other. These are commonly called the quadrature QEPA and QEPB signals. The clockwise direction for most encoders is defined as the QEPA channel going positive before the QEPB channel and vice versa.

The encoder wheel typically makes one revolution for every revolution of the motor or the wheel can be at a geared rotation ratio with respect to the motor. Therefore, the frequency of the digital signal coming from the QEPA and QEPB outputs varies proportionally with the velocity of the motor. For example, a 2000-line encoder directly coupled to a motor running at 5000 revolutions per minute (rpm) results in a frequency of 166.6KHz, so by measuring the frequency of either the QEPA or QEPB output, the processor can determine the velocity of the motor.

For more information, see *Enhanced Quadrature Encoder Pulse (EQEP) Module* section in *Peripherals* chapter in the device TRM.

7.4.2.10 General-Purpose Memory Controller (GPMC)

The General-Purpose Memory Controller is a unified memory controller dedicated for interfacing with external memory devices like:

- Asynchronous SRAM-like memories and application-specific integrated circuit (ASIC) devices
- Asynchronous, synchronous, and page mode (available only in non-multiplexed mode) burst NOR flash devices
- NAND flash
- Pseudo-SRAM devices

For more information, see *General-Purpose Memory Controller* section in *Peripherals* chapter in the device TRM.

7.4.2.11 I2C

The Inter-IC Bus (I2C) interface is implemented using the mshsi2c module. This peripheral implements the multi-controller I2C bus, which allows serial transfer of 8-bit data to and from other I2C controller and target devices, through a two-wire interface.

The I2C module supports the following main features:

- Compliant with Philips I2C specification version 2.1
- Supported Speeds:
 - Standard mode (up to 100 K bits/s)
 - Fast mode (up to 400 K bits/s)
 - High-speed mode (up to 3.4M bits/s), I2C0 and MCU_I2C0 only
- Multi-controller transmitter and target receiver mode
- Multi-controller receiver and target transmitter mode
- Combined controller transmit/receive and receive/transmit modes
- 7-bit and 10-bit device addressing modes
- Built-in 32-byte FIFO for buffered read or write
- Programmable multi-target channel (responds to 4 separate addresses)
- Programmable clock generation
- Support for asynchronous wake-up
- One interrupt line

For more information, see *Inter-Integrated Circuit (I2C) Interface* section in *Peripherals* chapter in the device TRM.

7.4.2.12 MCAN

The Controller Area Network (CAN) is a serial communications protocol which efficiently supports distributed real-time control with a high level of security. CAN has high immunity to electrical interference and the ability

to self-diagnose and repair data errors. In a CAN network, many short messages are broadcast to the entire network, which provides for data consistency in every node of the system.

The MCAN module supports both classic CAN and CAN FD (CAN with Flexible Data-Rate) specifications. CAN FD feature allows high throughput and increased payload per data frame. The classic CAN and CAN FD devices can coexist on the same network without any conflict.

The device supports 2 MCAN modules

For more information, see *Modular Controller Area Network (MCAN)* section in *Peripherals* chapter in the device TRM.

7.4.2.13 MCRC Controller

VBUSM CRC controller is a module which is used to perform CRC (Cyclic Redundancy Check) to verify the integrity of a memory system. A signature representing the contents of the memory is obtained when the contents of the memory are read into MCRC Controller. The responsibility of MCRC controller is to calculate the signature for a set of data and then compare the calculated signature value against a pre-determined good signature value. MCRC controller provides four channels to perform CRC calculation on multiple memories in parallel and can be used on any memory system. Channel 1 can also be put into data trace mode, where MCRC controller compresses each data being read through CPU read data bus.

For more information, see *MCRC Controller* section in *Interprocessor Communication* chapter in the device TRM.

7.4.2.14 MCSPI

The MCSPI module is a multichannel transmit/receive, controller/peripheral synchronous serial bus.

There are total of seven MCSPI modules in the device.

For more information, see *Multichannel Serial Peripheral Interface (MCSPI)* section in *Peripherals* chapter in the device TRM.

7.4.2.15 MMCSD

There are two Multi-Media Card/Secure Digital (MMCSD) modules inside the device - MMCSD0 and MMCSD1. Each MMCSD module includes one MMCSD Host Controller, where MMCSD0 is associated with MMC0 and MMCSD1 is associated with MMC1.

The MMCSD Host Controller supports:

- One controller with 8-bit wide data bus
- One controller with 4-bit wide data bus
- Support of eMMC5.1 Host Specification (JESD84-B51)
- Support of SD Host Controller Standard Specification - SDIO 3.00
- Integrated DMA controller supporting SD Advanced DMA - ADMA2 and ADMA3
- eMMC Electrical Standard 5.1 (JESD84-B51)
- Multi-Media card features:
 - Backward compatible with earlier eMMC standards
 - Legacy MMC SDR: 1.8V, 8/4/1-bit bus width, 0-25MHz, 25/12.5/3.125 MB/s
 - High Speed SDR: 1.8V, 8/4/1-bit bus width, 0-50MHz, 50/25/6.25 MB/s
 - High Speed DDR: 1.8V, 8/4-bit bus width, 0-50MHz, 100/50 MB/s
 - HS200 SDR: 1.8V, 0-200MHz, 8/4-bit bus width, 200/100 MB/s
- SD card support: SDIO, SDR12, SDR25, SDR50, DDR50
- System bus interface: CBA 4.0 VBUSM initiator port with 64-bit data width and 64-bit address, little Endian only
- Configuration bus interface: CBA 4.0 VBUSM with 32-bit data width, 32-bit aligned accesses only, linear incrementing addressing mode, little Endian only

For more information, see *Multi-Media Card/Secure Digital (MMCSD) Interface* section in *Peripherals* chapter in the device TRM.

7.4.2.16 OSPI

The Octal Serial Peripheral Interface (OSPI) module is a kind of Serial Peripheral Interface (SPI) module which allows single, dual, quad or octal read and write access to external flash devices. This module has a memory mapped register interface, which provides a direct memory interface for accessing data from external flash devices, simplifying software requirements.

The OSPI module is used to transfer data, either in a memory mapped direct mode (for example a processor wishing to execute code directly from external flash memory), or in an indirect mode where the module is set-up to silently perform some requested operation, signaling its completion via interrupts or status registers. For indirect operations, data is transferred between system memory and external flash memory via an internal SRAM which is loaded for writes and unloaded for reads by a device controller at low latency system speeds. Interrupts or status registers are used to identify the specific times at which this SRAM should be accessed using user programmable configuration registers.

For more information, see *Octal Serial Peripheral Interface (OSPI)* section in *Peripherals* chapter in the device TRM.

7.4.2.17 Peripheral Component Interconnect Express (PCIe)

The PCIe subsystem supports the following main features:

- Dual mode – root port (RP) or end point (EP) modes.
- 1-lane configuration with up to 5.0GT/lane.
- 62.5/125MHz operation on PIPE interface for Gen1/Gen2 respectively
- Constant 32-bit PIPE width for Gen1/Gen2 modes
- Maximum outbound payload size of 128 bytes
- Maximum inbound payload size of 128 bytes
- Maximum remote read request size of 4K bytes
- Maximum number of nonposted outstanding transactions: 8 on each VBUSM interface.
- Four virtual channels (4VC)
- Resizable BAR capability
- SRIS support
- Power Management
 - L1 Power Management Substate support
 - D1 support
 - L1 Power Shutoff support
- Legacy, MSI, and MSI-X interrupt support
- 32 outbound address translation regions
- Precision time measurement (PTM)

For more information, see *Peripheral Component Interconnect Express (PCIe) Subsystem* section in *Peripherals* chapter in the device TRM.

7.4.2.18 Serializer/Deserializer (SerDes) PHY

Integrated in the MAIN domain is one instance of high-speed differential interface implemented with Serializer/Deserializer (SerDes) Multi-protocol Multi-link PHY with the following main blocks:

- Single-lane SerDes PHY with common module for peripheral and Tx clocking handling
- Physical coding sub-block for data translation from/to the parallel interface, as well as data encoding/decoding and symbol alignment
- MUX module for device interface multiplexing into a single SerDes lane (Tx and Rx)
- A wrapper for sending control and reporting status signals from the SerDes and muxes

For more information, see *Serializer/Deserializer (SerDes)* section in *Peripherals* chapter in the device TRM.

7.4.2.19 Real Time Interrupt (RTI/WWDT)

This section describes the Real Time Interrupt (RTI) modules with Windowed Watchdog Timer (WWDT) functionality for the device.

For more information, see *Real Time Interrupt (RTI/WWDT) Module* section in *Peripherals* chapter of the device TRM.

7.4.2.20 Dual Mode Timer (DMTIMER)

The Dual Mode Timer (DMTIMER) module supports the following main features:

- Interrupts generated on overflow, compare, and capture events
- Free running 32-bit upward counter
- Supported operating modes:
 - Compare and capture modes
 - Auto-reload mode
 - Start-stop mode
- Programmable divider clock source (2^n with $n=[0:8]$)
- Dedicated input trigger for capture mode, and dedicated output trigger/PWM (pulse width modulation) signal
- On the fly read/write register (while counting)
- Generate 1ms tick with 32768Hz functional clock

For more information, see *Timers* section in *Peripherals* chapter in the device TRM.

7.4.2.21 UART

The UART module supports the following main features:

- 16C750 compatibility
- Baud rate from 300bps up to 12Mbps (MCU_UART0 and MCU_UART1 limited to 3.7Mbps)
- Auto-baud between 1200bps and 115.2Kbps
- Software/hardware flow control
 - Programmable Xon/Xoff characters
 - Programmable Auto-RTS and Auto CTS
- Programmable serial interface characteristics
 - 5-, 6-, 7-, 8-bit characters
 - Even, odd, mark (always 1), space (always 0), or no parity (non-parity bit frame) bit generation and detection
 - 1-, 1.5-, or 2-stop bit generation
- Optional multi-drop transmission
- Configurable time-guard feature
- False start bit detection
- Line break generation and detection
- Modem control functions on UART0 (CTS, RTS, DSR, DTR, RI, and DCD)
- Fully prioritized interrupt system controls
- Internal test and loopback capabilities
- RS-485 External transceiver auto flow control support

For more information, see *Universal Synchronous/Asynchronous Receiver/Transmitter (UART)* section in *Peripherals* chapter in the device TRM.

7.4.2.22 Universal Serial Bus Subsystem (USBSS)

The Universal Serial Bus Subsystem (USBSS) module supports the following main features:

General USB interface:

- Compliant with USB 3.1 specification
- Compliant with xHCI 1.1 specification
- Port configurable as:
 - USB host:
 - SuperSpeed Gen 1 (5Gbps)
 - High-speed (480Mbps)

- Full-speed (12Mbps)
- Low-speed (1.5Mbps)
- USB device/peripheral:
 - High-speed (480Mbps)
 - Full-speed (12Mbps)
- USB Dual-Role device

USB Host mode features:

- 64 slots
- Up to 96 periodic simultaneous endpoints
- 256 primary streams
- MSI
- Root hub

For more information, see *Universal Serial Bus (USB) Subsystem* section in *Peripherals* chapter in the device TRM.

8 Applications, Implementation, and Layout

Note

Information in the following applications sections is not part of the TI component specification, and TI does not warrant its accuracy or completeness. TI's customers are responsible for determining suitability of components for their purposes, as well as validating and testing their design implementation to confirm system functionality.

8.1 Device Connection and Layout Fundamentals

8.1.1 Power Supply

8.1.1.1 Power Supply Designs

The power supply implementation for this device requires a minimum of four sources when using ALX packaged devices (or five sources when using ALV/ANI packaged devices) for the following voltage domains: 0.85V CORE and RAM supplies, 3.3V IO supply, 1.8V IO supply and 1V8 analog supply. The ALV/ANI package requires an additional source to supply the 1.1V/1.2V DDR IO supply. Refer to the evaluation module or starter kit design files to better understand how specific supply pins can be grouped together. The power solution can be implemented with general purpose Power Management ICs (PMICs) or discrete regulators like DCDCs and LDOs. [TPS65219](#) is an example of a cost and space optimized PMIC with integrated DCDCs, LDOs, multi-function digital signals, sequencer, and supervisor providing the full power solution to supply the processor and principal peripherals. For the most up to date power collateral, visit the [TI's Power supply solutions](#) website.

Note

The device power supply implementation requires a dedicated 1.8V LDO to supply VPP only during eFuse programming. This LDO is optional and only needed if on-board eFuse programming is required.

8.1.1.2 Power Distribution Network Implementation Guidance

The [Sitara Processor Power Distribution Networks: Implementation and Analysis](#) provides guidance for successful implementation of the power distribution network. This includes PCB stackup guidance as well as guidance for optimizing the selection and placement of the decoupling capacitors. TI *only* supports designs that follow the board design guidelines contained in the application report.

8.1.2 External Oscillator

For more information about External Oscillators, see the *Clock Specifications* section.

8.1.3 JTAG, EMU, and TRACE

Texas Instruments supports a variety of eXtended Development System (XDS™) JTAG controllers with various debug capabilities beyond only JTAG support. A summary of this information is available in the [XDS Target Connection Guide](#).

For recommendations on JTAG, EMU, and TRACE routing, see the [Emulation and Trace Headers Technical Reference Manual](#)

8.1.4 Unused Pins

For more information about Unused Pins, see the [Pin Connectivity Requirements](#) section.

8.2 Peripheral- and Interface-Specific Design Information

8.2.1 General Routing Guidelines

The following paragraphs detail the routing guidelines that must be observed when routing the various functional LVCMOS interfaces.

- Line spacing:
 - For a line width equal to W , the spacing between two lines must be $2W$, at least. This minimizes the crosstalk between switching signals between the different lines. On the PCB, this is not achievable everywhere (for example, when breaking signals out from the device package), but it is recommended to follow this rule as much as possible. When violating this guideline, minimize the length of the traces running parallel to each other (see [Figure 8-1](#)).

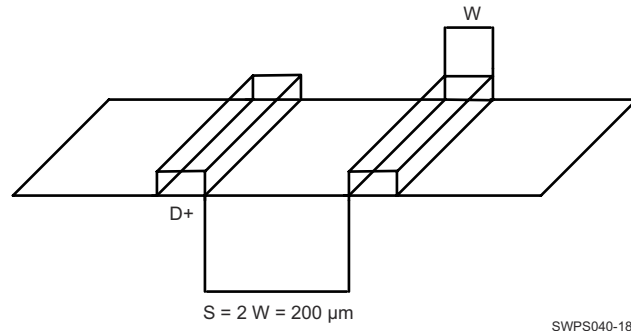

Figure 8-1. Ground Guard Illustration

- Length matching (unless otherwise specified):
 - For bus or traces at frequencies less than 10MHz, the trace length matching (maximum length difference between the longest and the shortest lines) must be less than 25mm.
 - For bus or traces at frequencies greater than 10MHz, the trace length matching (maximum length difference between the longest and the shortest lines) must be less than 2.5mm.
- Characteristic impedance
 - Unless otherwise specified, the characteristic impedance for single-ended interfaces is recommended to be between 35- Ω and 65- Ω .
- Multiple peripheral support
 - For interfaces where multiple peripherals have to be supported in the star topology, the length of each branch has to be balanced. Before closing the PCB design, it is highly recommended to verify signal integrity based on simulations including actual PCB extraction.

8.2.2 DDR Board Design and Layout Guidelines

The goal of the [AM64x\AM243x DDR Board Design and Layout Guidelines](#) is to make the DDR system implementation straightforward for all designers. Requirements have been distilled down to a set of layout and routing rules that allow designers to successfully implement a robust design for the topologies that TI supports. TI only supports board designs using DDR4 or LPDDR4 memories that follow the guidelines in this document.

8.2.3 OSPI/QSPI/SPI Board Design and Layout Guidelines

The following section details the PCB routing guidelines that must be observed when connecting OSPI, QSPI, or SPI devices.

8.2.3.1 No Loopback, Internal PHY Loopback, and Internal Pad Loopback

- The OSPI[x]_CLK output pin must be connected to the CLK input pin of the attached OSPI/QSPI/SPI device
- The signal propagation delay from the OSPI[x]_CLK pin to the attached OSPI/QSPI/SPI device CLK pin (A to B) must be $\leq 450\text{ps}$ ($\sim 7\text{cm}$ as stripline or $\sim 8\text{cm}$ as microstrip)
- The signal propagation delay of each OSPI[x]_D[y] and OSPI[x]_CSn[z] pin to the corresponding attached OSPI/QSPI/SPI device data and control pin (E to F, or F to E) must be approximately equal to the signal propagation delay from the OSPI[x]_CLK pin to the attached OSPI/QSPI/SPI device CLK pin (A to B)
- 50 Ω PCB routing is recommended along with series terminations, as shown in [Figure 8-2](#)
- Propagation delays and matching:
 - (A to B) $\leq 450\text{ps}$
 - (E to F, or F to E) = ((A to B) $\pm 60\text{ps}$)

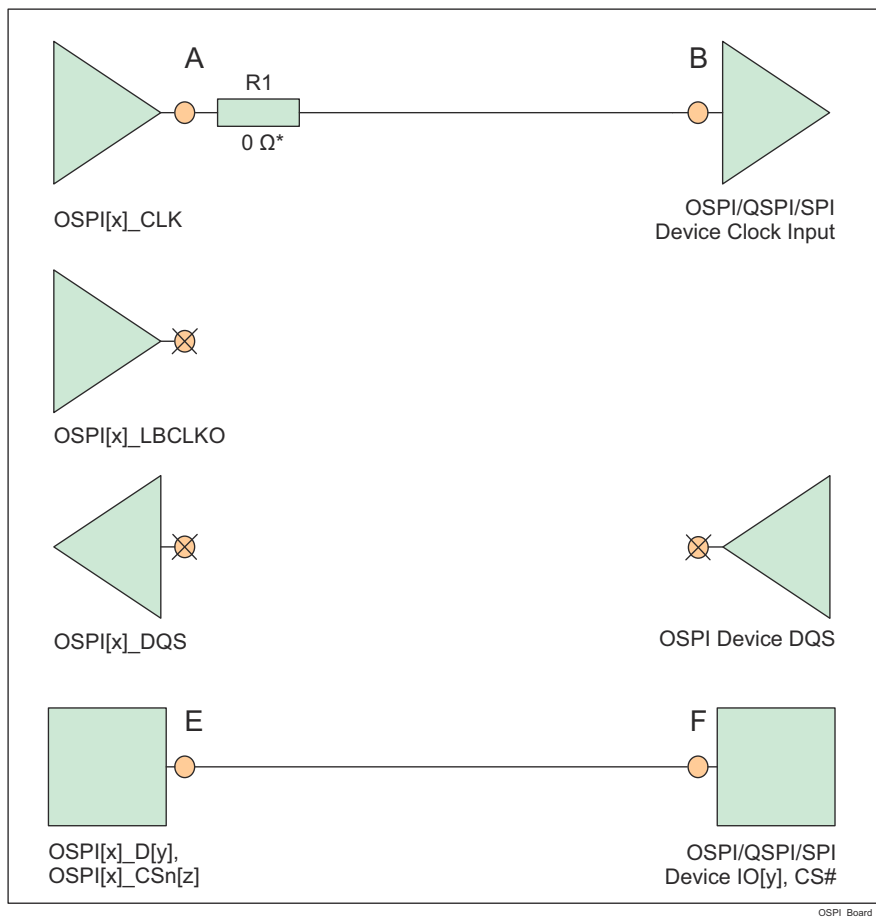

* 0 Ω resistor (R1), located as close as possible to the OSPI[x]_CLK pin, is placeholder for fine tuning, if needed.

Figure 8-2. OSPI Connectivity Schematic for No Loopback, Internal PHY Loopback, and Internal Pad Loopback

8.2.3.2 External Board Loopback

- The OSPI[x]_CLK output pin must be connected to the CLK input pin of the attached OSPI/QSPI/SPI device
- The OSPI[x]_LBCLKO output pin must be looped back to the OSPI[x]_DQS input pin
- The signal propagation delay of the OSPI[x]_LBCLKO pin to the OSPI[x]_DQS pin (C to D) must be approximately twice the propagation delay of the OSPI[x]_CLK pin to the attached OSPI/QSPI/SPI device CLK pin (A to B)
- The signal propagation delay of each OSPI[x]_D[y] and OSPI[x]_CSn[z] pin to the corresponding attached OSPI/QSPI/SPI device data and control pin (E to F, or F to E) must be approximately equal to the signal propagation delay from the OSPI[x]_CLK pin to the attached OSPI/QSPI/SPI device CLK pin (A to B)
- 50Ω PCB routing is recommended along with series terminations, as shown in [Figure 8-3](#)
- Propagation delays and matching:
 - (C to D) = 2 x ((A to B) ± 30ps), see the exception note below.
 - (E to F, or F to E) = ((A to B) ± 60ps)

Note

The External Board Loopback hold time requirement (defined by parameter number O16 in [Table 6-106, OSPI0 Timing Requirements - PHY DDR Mode](#)) may be larger than the hold time provided by a typical OSPI/QSPI/SPI device. In this case, the propagation delay of OSPI[x]_LBCLKO pin to the OSPI[x]_DQS pin (C to D) can be reduced to provide additional hold time.

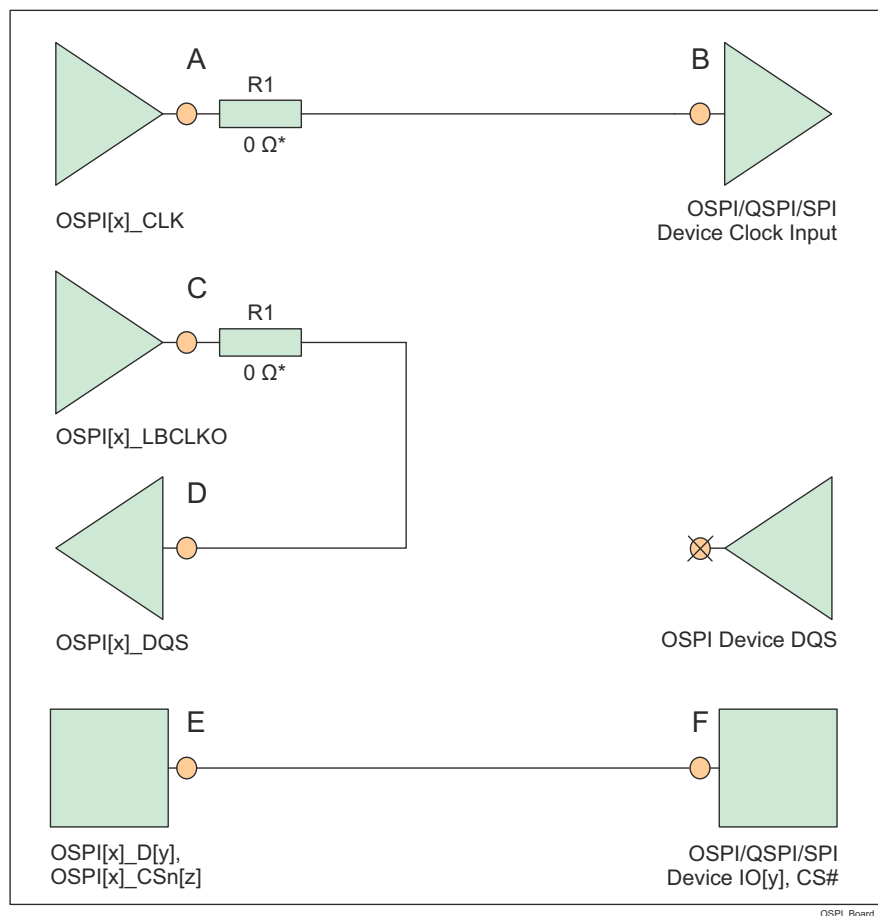

* 0Ω resistor (R1), located as close as possible to the OSPI[x]_CLK and OSPI[x]_LBCLKO pins, is a placeholder for fine tuning, if needed.

Figure 8-3. OSPI Connectivity Schematic for External Board Loopback

8.2.3.3 DQS (only available in Octal SPI devices)

- The OSPI[x]_CLK output pin must be connected to the CLK input pin of the attached OSPI/QSPI/SPI device
- The DQS pin of the attached OSPI/QSPI/SPI device must be connected to OSPI[x]_DQS pin
- The signal propagation delay from the attached OSPI/QSPI/SPI device DQS pin to the OSPI[x]_DQS pin (D to C) must be approximately equal to the signal propagation delay from the OSPI[x]_CLK pin to the attached OSPI/QSPI/SPI device CLK pin (A to B)
- The signal propagation delay of each OSPI[x]_D[y] and OSPI[x]_CSn[z] pin to the corresponding attached OSPI/QSPI/SPI device data and control pin (E to F, or F to E) must be approximately equal to the signal propagation delay from the OSPI[x]_CLK pin to the attached OSPI/QSPI/SPI device CLK pin (A to B)
- 50Ω PCB routing is recommended along with series terminations, as shown in [Figure 8-4](#)
- Propagation delays and matching:
 - (D to C) = ((A to B) ± 30ps)
 - (E to F, or F to E) = ((A to B) ± 60ps)

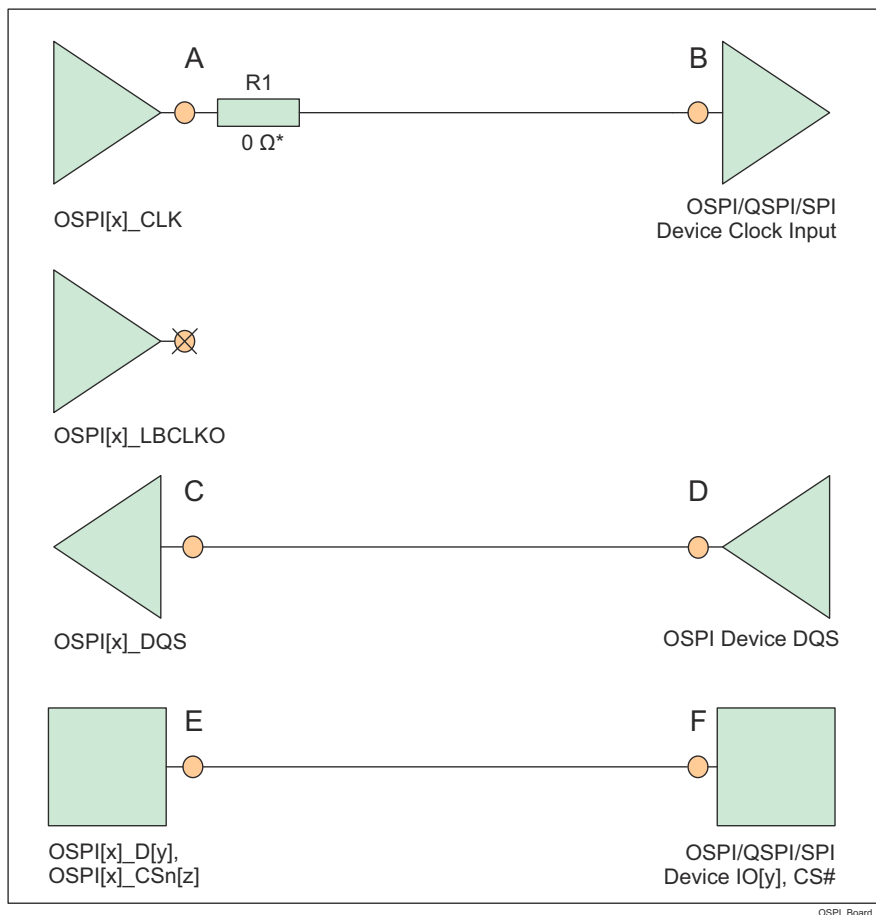

* 0Ω resistor (R1), located as close as possible to the OSPI[x]_CLK pin, is a placeholder for fine tuning, if needed.

Figure 8-4. OSPI Connectivity Schematic for DQS

8.2.4 USB VBUS Design Guidelines

The USB 3.1 specification allows the VBUS voltage to be as high as 5.5V for normal operation, and as high as 20V when the Power Delivery addendum is supported. Some automotive applications require a max voltage to be 30V.

The device requires the VBUS signal voltage be scaled down using an external resistor divider (as shown in the [Figure 8-5](#)), which limits the voltage applied to the actual device pin (USBn_VBUS). The tolerance of these external resistors should be equal to or less than 1%, and the leakage current of Zener diode at 5V should be less than 100nA.

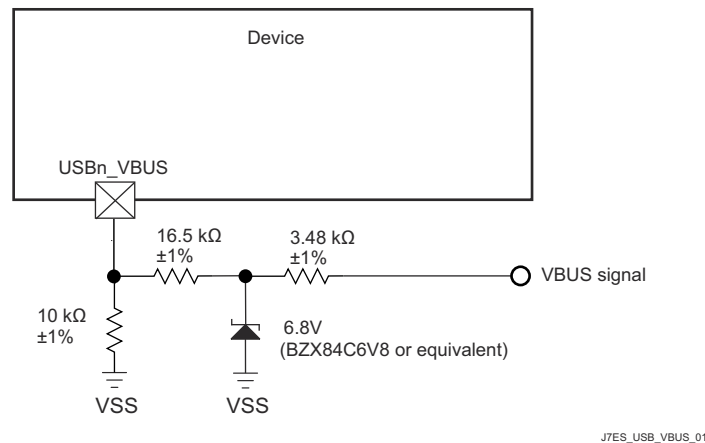

Figure 8-5. USB VBUS Detect Voltage Divider / Clamp Circuit

The USB0_VBUS pin can be considered to be fail-safe because the external circuit in [Figure 8-5](#) limits the input current to the actual device pin in a case where VBUS is applied while the device is powered off.

8.2.5 System Power Supply Monitor Design Guidelines

The VMON_VSYS pin provides a way to monitor a system power supply. This system power supply is typically a single pre-regulated power source for the entire system and can be connected to the VMON_VSYS pin via an external resistor divider circuit. This system supply is monitored by comparing the external voltage divider output voltage to an internal voltage reference, where a power fail event is triggered when the voltage applied to VMON_VSYS drops below the internal reference voltage. The actual system power supply voltage trip point is determined by the system designer when selecting component values used to implement the external resistor voltage divider circuit.

When building the resistor divider circuit the designer must understand various factors which contribute to variability in the system power supply monitor trip point. The first thing to consider is the initial accuracy of the VMON_VSYS input threshold which has a nominal value of 0.45V, with a variation of $\pm 3\%$. Precision 1% resistors with similar thermal coefficient are recommended for implementing the resistor voltage divider. This minimizes variability contributed by resistor value tolerances. Input leakage current associated with VMON_VSYS must also be considered since any current flowing into the pin creates a loading error on the voltage divider output. The VMON_VSYS input leakage current can be in the range of 10nA to 2.5 μ A when applying 0.45V.

Note

The resistor voltage divider shall be designed such that the output voltage never exceeds the maximum value defined in the *Recommended Operating Conditions* section, during normal operating conditions.

[Figure 8-6](#) presents an example, where the system power supply is nominally 5V and the maximum trigger threshold is 5V - 10%, or 4.5V.

For this example, the designer must understand which variables effect the maximum trigger threshold when selecting resistor values. A device which has a VMON_VSYS input threshold of $0.45\text{V} + 3\%$ needs to be considered when trying to design a voltage divider that doesn't trip until the system supply drops 10%. The effect of resistor tolerance and input leakage also needs to be considered, but the contribution to the maximum trigger point is not obvious. When selecting component values which produce a maximum trigger voltage, the system designer must consider a condition where the value of R1 is 1% low and the value of R2 is 1% high combined with a condition where input leakage current for the VMON_VSYS pin is $2.5\mu\text{A}$. When implementing a resistor divider where $R1 = 4.81\text{k}\Omega$ and $R2 = 40.2\text{k}\Omega$, the result is a maximum trigger threshold of 4.517V .

Once component values have been selected to satisfy the maximum trigger voltage as described above, the system designer can determine the minimum trigger voltage by calculating the applied voltage that produces an output voltage of $0.45\text{V} - 3\%$ when the value of R1 is 1% high and the value of R2 is 1% low, and the input leakage current is 10nA , or zero. Using an input leakage of zero with the resistor values given above, the result is a minimum trigger threshold of 4.013V .

This example demonstrates a system power supply voltage trip point that ranges from 4.013V to 4.517V . Approximately 250mV of this range is introduced by VMON_VSYS input threshold accuracy of $\pm 3\%$, approximately 150mV of this range is introduced by resistor tolerance of $\pm 1\%$, and approximately 100mV of this range is introduced by loading error when VMON_VSYS input leakage current is $2.5\mu\text{A}$.

The resistor values selected in this example produces approximately $100\mu\text{A}$ of bias current through the resistor divider when the system supply is 4.5V . The 100mV of loading error mentioned above can be reduced to about 10mV by increasing the bias current through the resistor divider to approximately 1mA . So resistor divider bias current vs loading error is something the system designer needs to consider when selecting component values.

The system designer must also consider implementing a noise filter on the voltage divider output since VMON_VSYS has minimum hysteresis and a high-bandwidth response to transients. This can be done by installing a capacitor across R1 as shown in Figure 8-6. However, the system designer must determine the response time of this filter based on system supply noise and expected response to transient events.

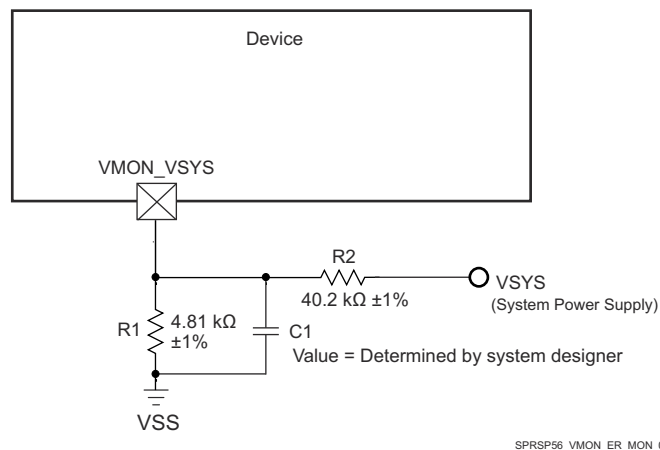

Figure 8-6. System Supply Monitor Voltage Divider Circuit

VMON_1P8_MCU and VMON_1P8_SOC pins provide a way to monitor external 1.8V power supplies. These pins must be connected directly to their respective power source. An internal resistor divider with software control is implemented inside the SoC for each of these pins. Software can program each internal resistor divider to create appropriate under voltage and over voltage interrupts.

VMON_3P3_MCU and VMON_3P3_SOC pins provide a way to monitor external 3.3V power supplies. These pins must be connected directly to their respective power source. An internal resistor divider with software control is implemented inside the SoC for each of these pins. Software can program each internal resistor divider to create appropriate under voltage and over voltage interrupts.

8.2.6 High Speed Differential Signal Routing Guidance

The [High Speed Interface Layout Guidelines](#) provides guidance for successful routing of the high speed differential signals. This includes PCB stackup and materials guidance as well as routing skew, length and spacing limits. TI supports *only* designs that follow the board design guidelines contained in the application note.

8.2.7 Thermal Solution Guidance

The [Thermal Design Guide for DSP and ARM Application Processors](#) provides guidance for successful implementation of a thermal solution for system designs containing this device. This document provides background information on common terms and methods related to thermal solutions. TI only supports designs that follow system design guidelines contained in the application note.

8.3 Clock Routing Guidelines

8.3.1 Oscillator Routing

When designing the printed-circuit board:

- Place all crystal circuit components as close as possible to the respective device pins.
- Route the crystal circuit traces on the outer layer of the PCB and minimize trace lengths to reduce parasitic capacitance and minimize crosstalk from other signals.
- Place a continuous ground plane on the adjacent layer of the PCB such that it is under all crystal circuit components and crystal circuit traces.
- Route a ground guard around the crystal circuit components to shield it from any adjacent signals routed on the same layer as the crystal circuit traces. Insert multiple vias to stitch down the ground guard such that it does not have any unterminated stubs.
- Route a ground guard between the MCU_OSC0_XI and MCU_OSC0_XO signals to shield the MCU_OSC0_XI signal from the MCU_OSC0_XO signal. Insert multiple vias to stitch down the ground guard such that it does not have any unterminated stubs.
- Connect all crystal circuit ground connections and ground guard connections directly to the adjacent layer ground plane, and the device VSS ground plane if they are implemented separately on different layers of the PCB.

Note

Implementing a ground guard between the MCU_OSC0_XI and MCU_OSC0_XO signals is critical to minimize shunt capacitance between the two signals. Routing these two signals adjacent to each other without a ground guard between them will effectively reduce the gain of the oscillator amplifier, which reduces its ability to start oscillation.

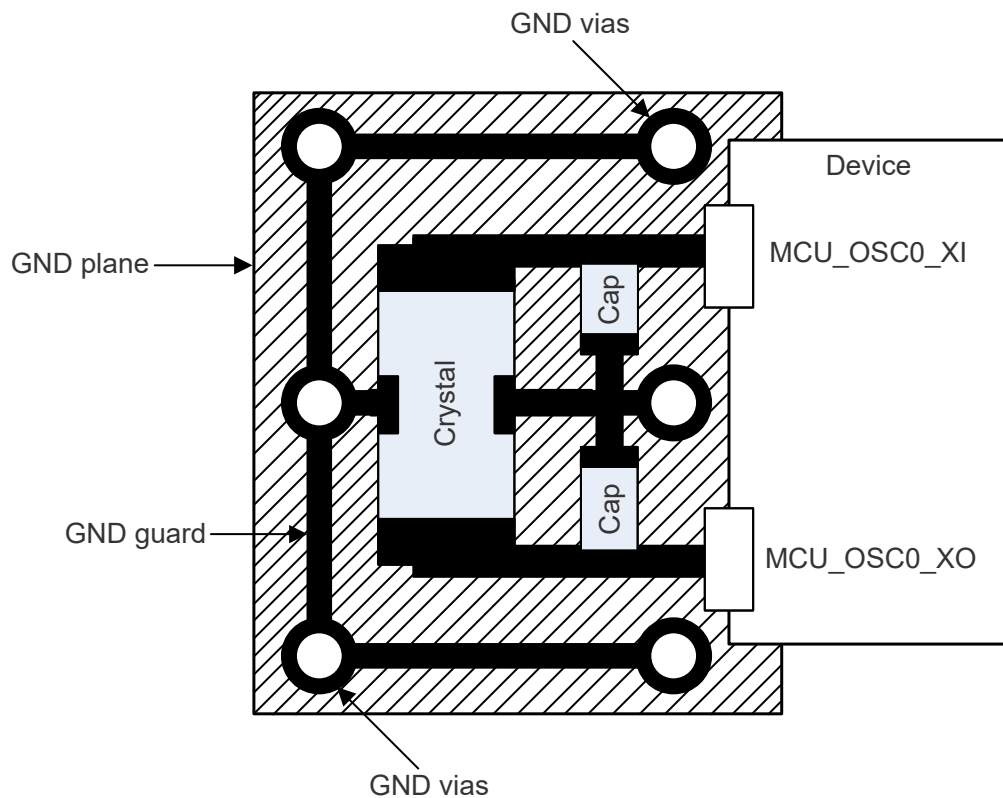

Figure 8-7. MCU_OSC0 PCB requirements

8.3.2 Oscillator Ground Connection

Refer to [Section 6.11.4.1.1](#) for the Oscillator Ground Connection diagram.

9 Device and Documentation Support

9.1 Device Nomenclature

To designate the stages in the product development cycle, TI assigns prefixes to the part numbers of all embedded processor devices and support tools. Each device has one of three prefixes: X, P, or null (no prefix) (for example, XAM2434ASFGGAALX). Texas Instruments recommends two of three possible prefix designators for related support tools: TMDX and TMDS. These prefixes represent evolutionary stages of product development from engineering prototypes (TMDX) through fully qualified production devices and tools (TMDS).

Device development evolutionary flow:

- X** Experimental device that is not necessarily representative of the device's final electrical specifications and may not use production assembly flow.
- P** Prototype device that is not necessarily the final silicon die and may not necessarily meet final electrical specifications.
- null (BLANK)** Production version of the silicon die that is fully qualified and meets final electrical specifications.

Support tool development evolutionary flow:

- TMDX** Development-support product that has not yet completed Texas Instruments internal qualification testing.
- TMDS** Fully-qualified development-support product.

X and P devices and TMDX development-support tools are shipped against the following disclaimer:

"Developmental product is intended for internal evaluation purposes."

Production devices and TMDS development-support tools have been characterized fully, and the quality and reliability of the device have been demonstrated fully. TI's standard warranty applies.

Predictions show that prototype devices (X or P) have a greater failure rate than the standard production devices. Texas Instruments recommends that these devices not be used in any production system because their expected end-use failure rate still is undefined. Only qualified production devices are to be used.

For orderable part numbers of AM243x devices in the ALV/ANI or ALX package type, see the Package Option Addendum at the end of this document, the TI website (ti.com), or contact your TI sales representative.

9.1.1 Standard Package Symbolization

Note

Some devices may have a cosmetic circular marking visible on the top of the device package which results from the production test process. In addition, some devices may also show a color variation in the package substrate which results from the substrate manufacturer. These differences are cosmetic only with no reliability impact.

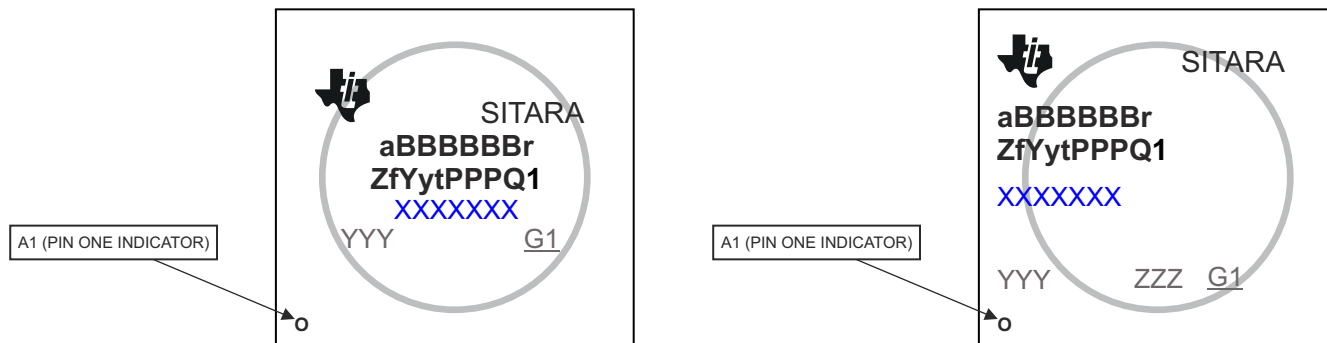

Figure 9-1. Printed Device Reference

9.1.2 Device Naming Convention

Table 9-1. Nomenclature Description

| FIELD PARAMETER | FIELD DESCRIPTION | VALUE | DESCRIPTION |
|-----------------|--|----------------------|---|
| a | Device Evolution Stage | X | Prototype |
| | | P | Preproduction (production test flow, no reliability data) |
| | | BLANK ⁽¹⁾ | Production |
| BBBBBB | Base Production Part Number | AM2434 | (See Device Comparison) |
| | | AM2432 | |
| | | AM2431 | |
| r | Device Revision | A | Silicon Revision (SR) 1.0 |
| | | B | Silicon Revision (SR) 2.0 |
| Z | Device Speed Grades | S | (See Speed Grade Maximum Frequency) |
| | | K | |
| f | Features (See Device Comparison) | C | All PRU_ICSSG features are enabled except for industrial communication support. PRU_ICSSG industrial communication interfaces include Ethernet networking (MII/RGMII, MDIO), Sigma-Delta (SD) decimation, and three channel peripheral interface (EnDat 2.2 and BiSS) |
| | | D | Features supported by C, plus PRU_ICSSG industrial communication subsystem are enabled |
| | | E | Features supported by D, plus CAN FD, and hardware support for EtherCAT and other Ethernet protocols requiring hardware auto-forwarding feature are enabled |
| | | F | Features supported by E, plus Pre-integrated Stacks are enabled |
| Y | Functional Safety | G | Non-Functional Safety |
| | | F | Functional Safety |
| y | Security | G | Non-Secure |
| | | H | Secure |
| t | Temperature ⁽²⁾ | A | -40°C to 105°C - Extended Industrial (See Recommended Operating Conditions) |
| | | I | -40°C to 125°C - 125°C Industrial (See Recommended Operating Conditions and Section 6.3 Power-On Hours (POH)) |
| PPP | Package Designator | ALV | ALV Package FCBGA-N441 (17.2mm × 17.2mm - 0.8mm pitch) |
| | | ANI | ANI Package FCBGA-N441 (17.2mm × 17.2mm - 0.8mm pitch) |
| | | ALX | ALX Package FCCSP-N293 (11.0mm × 11.0mm - 0.5mm pitch) |
| c | Carrier Type | R | Tape and Reel |
| | | BLANK | Tray |
| Q1 | Automotive Designator | Q | Auto Qualified (Q100) |
| | | EP | Enhanced Product |
| | | BLANK ⁽¹⁾ | Standard |
| XXXXXXX | | | Lot Trace Code (LTC) |
| YYY | | | Production Code; For TI use only |
| O | | | Pin one designator |
| G1 | | | ECAT—Green package designator |

(1) BLANK fields in the symbol or part number are collapsed so there are no gaps between characters.

(2) Applies to device max junction temperature. See [Power-On Hours \(POH\)](#) for more details.

9.2 Tools and Software

The following Development Tools support development for TI's Embedded Processing platforms:

Development Tools

Code Composer Studio™ Integrated Development Environment Code Composer Studio (CCS) Integrated Development Environment (IDE) is a development environment that supports TI's Microcontroller and Embedded Processors portfolio. Code Composer Studio comprises a suite of tools used to develop and debug embedded applications. The tool includes an optimizing C/C++ compiler, source code editor, project build environment, debugger, profiler, and many other features. The intuitive IDE provides a single user interface taking you through each step of the application development flow. Familiar tools and interfaces allow users to get started faster than ever before. Code Composer Studio combines the advantages of the Eclipse® software framework with advanced embedded debug capabilities from TI resulting in a compelling feature-rich development environment for embedded developers.

SysConfig Tool The System Configuration tool provides a graphical user interface (GUI) that simplifies device configuration. The tool is designed to simplify hardware and software configuration challenges to accelerate software development. SysConfig is available as part of the Code Composer Studio™ integrated development environment as well as a standalone application. Additionally SysConfig can be run in the cloud by visiting the [TI developer zone](#).

SysConfig allows developers to configure pins, peripherals, and other components, and automatically detects, exposes, and resolves conflicts to speed software development. In addition, the clock tree tool provides a visual implementation of the device clock connectivity.

The SysConfig tool generates output C header/code files that can be imported into software development kits (SDKs), enabling customers to configure their software in alignment with the specific hardware requirements.

For a complete listing of development-support tools for the processor platform, visit the Texas Instruments website at [ti.com](#). For information on pricing and availability, contact the nearest TI field sales office or authorized distributor.

9.3 Documentation Support

To receive notification of documentation updates, navigate to the device product folder on [ti.com](#). In the upper right corner, click the *Subscribe to updates* bell to register and receive a weekly digest of any product information that has changed. For change details, review the revision history included in any revised document.

The current documentation that describes the processor, related peripherals, and other technical collateral is listed below.

The following documents describe the AM243x family of devices.

Technical Reference Manual

AM243x/AM64x Processors Technical Reference Manual (SPRUIM2) The technical reference document details the overview, integration, environment, programming models, and functional descriptions for each peripheral and subsystem in the AM243x family of devices.

Errata

AM243x/AM64x Processors Silicon Errata (SPRZ457) The silicon errata document describes any known exceptions to the functional specifications for the device.

Note

Search for literature numbers on [ti.com](#).

9.3.1 Information About Cautions and Warnings

This document may contain cautions and warnings.

WARNING

A *warning* in documentation indicates that an action or precaution must be taken to avoid the risk of injury or death to personnel.

CAUTION

A *caution* in documentation indicates that an action or precaution must be taken to avoid the risk of damage to components or equipment.

The information in a caution or a warning is provided for your protection. Read each caution and warning carefully.

9.4 Support Resources

[TI E2E™ support forums](#) are an engineer's go-to source for fast, verified answers and design help — straight from the experts. Search existing answers or ask your own question to get the quick design help you need.

Linked content is provided "AS IS" by the respective contributors. They do not constitute TI specifications and do not necessarily reflect TI's views; see TI's [Terms of Use](#).

9.5 Trademarks

Sitara™, XDS™, Code Composer Studio™, and TI E2E™ are trademarks of Texas Instruments.

CoreSight™ is a trademark of Arm Limited (or its subsidiaries) in the US and/or elsewhere.

TrustZone®, Arm® are registered trademarks of Arm.

Cortex® is a registered trademark of Arm Limited (or its subsidiaries) in the US and/or elsewhere.

PCI-Express® is a registered trademark of PCI-SIG.

EtherCAT® is a registered trademark of Beckhoff Automation GmbH.

Eclipse® is a registered trademark of Eclipse Foundation AISBL.

All trademarks are the property of their respective owners.

9.6 Electrostatic Discharge Caution



This integrated circuit can be damaged by ESD. Texas Instruments recommends that all integrated circuits be handled with appropriate precautions. Failure to observe proper handling and installation procedures can cause damage.

ESD damage can range from subtle performance degradation to complete device failure. Precision integrated circuits may be more susceptible to damage because very small parametric changes could cause the device not to meet its published specifications.

9.7 Glossary

[TI Glossary](#) This glossary lists and explains terms, acronyms, and definitions.

10 Revision History

Changes from December 22, 2025 to June 3, 2026 (from Revision H (DECEMBER 2025) to Revision I (June 2026))

| | Page |
|---|------|
| • Global: Added ANI package option support to the device..... | 1 |
| • (Features): Added details for the new ANI package option..... | 1 |
| • (Device Comparison): Added a note clarifying that features availability may vary by package..... | 7 |
| • (Power-On Hours): Removed note referencing an application report..... | 104 |
| • (Speed Grade Maximum Frequency): Added ANI package option to the table..... | 107 |
| • (Thermal Resistance Characteristics): Added ANI package option to the table..... | 118 |
| • (MCU_OSC0 Switching Characteristics - Crystal Mode): Added ANI package option to the table..... | 136 |
| • (GPMC): Widened range of output load capacitance. Specified separate ranges for 133MHz Synchronous Mode and All other modes..... | 160 |
| • (GPMC and NOR Flash Timing Requirements — Synchronous Mode): Simplified MODE column to include only div_by_1_mode and not_div_by_1_mode. Changed column headers from GPMC_FCLK = 100MHz/133MHz to 32-bit data bus (up to 100MHz)/16-bit data bus (up to 133MHz). Simplified several parameter descriptions. Updated pin names to match Pin Attributes table. Updated the table notes. | 160 |
| • (GPMC and NOR Flash Switching Characteristics – Synchronous Mode): Removed the MODE column. Combined the GPMC_FCLK=100MHz and GPMC_FCLK=133MHz columns. Reduced F2 and F3 clk-csn maximum output delays. Changed the timing variable in parameters F3 and F11 to "D". Removed 2 of the F7 rows. Removed the "J" timing variable from the F15 and F17 parameters. Added byte enables for 32-bit data bus to F6, F7, F17, F19. Simplified several parameter descriptions. Updated pin names to match Pin Attributes table. Updated the table notes..... | 160 |
| • (GPMC and NOR Flash Timing Requirements – Asynchronous Mode): Removed the MODE column and the table note that described register configuration for div_by_1_mode. Added the correct table note for parameter FA21 | 169 |
| • (GPMC and NOR Flash Switching Characteristics – Asynchronous Mode): Removed the MODE column and redundant rows. Also removed the table note that described register configuration for div_by_1_mode. Moved links to table notes directly next to each letter. | 169 |
| • (GPMC and NAND Flash Timing Requirements – Asynchronous Mode): Removed the MODE column and the table note that described register configuration for div_by_1_mode..... | 176 |
| • (GPMC and NAND Flash Switching Characteristics – Asynchronous Mode): Removed the MODE column and the table note that described register configuration for div_by_1_mode. Added table notes and associated reference links for timing variables A, B, C, D, E, F, G, H, I, K, L, and M..... | 176 |
| • (MCSPi Switching Characteristics – Peripheral Mode): Updated values for parameters SS6 and SS7..... | 187 |
| • (Device Naming Convention): Updated Package Designator row (added ANI package option)..... | 261 |

| Changes from June 3, 2026 to June 12, 2026 (from Revision I (JUNE 2026) to Revision J (JUNE 2026)) | Page |
|---|-------------|
| • (Thermal Resistance Characteristics): Updated ANI package characteristics values..... | 118 |

11 Mechanical, Packaging, and Orderable Information

11.1 Packaging Information

The following pages include mechanical, packaging, and orderable information. This information is the most current data available for the designated devices. This data is subject to change without notice and revision of this document. For browser-based versions of this data sheet, refer to the left-hand navigation.

PACKAGING INFORMATION

| Orderable part number | Status (1) | Material type (2) | Package Pins | Package qty Carrier | RoHS (3) | Lead finish/ Ball material (4) | MSL rating/ Peak reflow (5) | Op temp (°C) | Part marking (6) |
|----------------------------------|---------------|----------------------|-------------------|-----------------------|-------------|--------------------------------------|-----------------------------------|--------------|----------------------------|
| AM2431BSDFHIALVR | Active | Production | FCBGA (ALV) 441 | 500 LARGE T&R | Yes | Call TI | Level-3-250C-168 HR | -40 to 125 | AM2431B SDFHIALV 709 |
| AM2431BSDFHIALVR.B | Active | Production | FCBGA (ALV) 441 | 500 LARGE T&R | Yes | Call TI | Level-3-250C-168 HR | -40 to 125 | AM2431B SDFHIALV 709 |
| AM2431BSDFHIALXR | Active | Production | FCCSP (ALX) 293 | 1000 LARGE T&R | Yes | Call TI | Level-3-250C-168 HR | -40 to 125 | AM2431B SDFHIALX 709 |
| AM2431BSDFHIALXR.B | Active | Production | FCCSP (ALX) 293 | 1000 LARGE T&R | Yes | Call TI | Level-3-250C-168 HR | -40 to 125 | AM2431B SDFHIALX 709 |
| AM2431BSDGHIALVR | Active | Production | FCBGA (ALV) 441 | 500 LARGE T&R | Yes | Call TI | Level-3-250C-168 HR | -40 to 125 | AM2431B SDGHIALV 709 |
| AM2431BSDGHIALVR.B | Active | Production | FCBGA (ALV) 441 | 500 LARGE T&R | Yes | Call TI | Level-3-250C-168 HR | -40 to 125 | AM2431B SDGHIALV 709 |
| AM2431BSDGHIALXR | Active | Production | FCCSP (ALX) 293 | 1000 LARGE T&R | Yes | Call TI | Level-3-250C-168 HR | -40 to 125 | AM2431B SDGHIALX 709 |
| AM2431BSDGHIALXR.B | Active | Production | FCCSP (ALX) 293 | 1000 LARGE T&R | Yes | Call TI | Level-3-250C-168 HR | -40 to 125 | AM2431B SDGHIALX 709 |
| AM2432BKEGHIALXR | Active | Production | FCCSP (ALX) 293 | 1000 LARGE T&R | Yes | Call TI | Level-3-250C-168 HR | -40 to 125 | AM2432B KEGHIALX 709 |
| AM2432BKEGHIALXR.B | Active | Production | FCCSP (ALX) 293 | 1000 LARGE T&R | Yes | Call TI | Level-3-250C-168 HR | -40 to 125 | AM2432B KEGHIALX 709 |
| AM2432BKFGHIALXR | Active | Production | FCCSP (ALX) 293 | 1000 LARGE T&R | Yes | Call TI | Level-3-250C-168 HR | -40 to 125 | AM2432B KFGHIALX 709 |

| Orderable part number | Status (1) | Material type (2) | Package Pins | Package qty Carrier | RoHS (3) | Lead finish/ Ball material (4) | MSL rating/ Peak reflow (5) | Op temp (°C) | Part marking (6) |
|----------------------------------|---------------|----------------------|-------------------|-----------------------|-------------|--------------------------------------|-----------------------------------|--------------|----------------------------|
| AM2432BKFGHIALXR.B | Active | Production | FCCSP (ALX) 293 | 1000 LARGE T&R | Yes | Call TI | Level-3-250C-168 HR | -40 to 125 | AM2432B KFGHIALX 709 |
| AM2432BSDFHIALVR | Active | Production | FCBGA (ALV) 441 | 500 LARGE T&R | Yes | Call TI | Level-3-250C-168 HR | -40 to 125 | AM2432B SDFHIALV 709 |
| AM2432BSDFHIALVR.B | Active | Production | FCBGA (ALV) 441 | 500 LARGE T&R | Yes | Call TI | Level-3-250C-168 HR | -40 to 125 | AM2432B SDFHIALV 709 |
| AM2432BSDFHIALXR | Active | Production | FCCSP (ALX) 293 | 1000 LARGE T&R | Yes | Call TI | Level-3-250C-168 HR | -40 to 125 | AM2432B SDFHIALX 709 |
| AM2432BSDFHIALXR.B | Active | Production | FCCSP (ALX) 293 | 1000 LARGE T&R | Yes | Call TI | Level-3-250C-168 HR | -40 to 125 | AM2432B SDFHIALX 709 |
| AM2432BSDGHIALVR | Active | Production | FCBGA (ALV) 441 | 500 LARGE T&R | Yes | Call TI | Level-3-250C-168 HR | -40 to 125 | AM2432B SDGHIALV 709 |
| AM2432BSDGHIALVR.B | Active | Production | FCBGA (ALV) 441 | 500 LARGE T&R | Yes | Call TI | Level-3-250C-168 HR | -40 to 125 | AM2432B SDGHIALV 709 |
| AM2432BSDGHIALXR | Active | Production | FCCSP (ALX) 293 | 1000 LARGE T&R | Yes | Call TI | Level-3-250C-168 HR | -40 to 125 | AM2432B SDGHIALX 709 |
| AM2432BSDGHIALXR.B | Active | Production | FCCSP (ALX) 293 | 1000 LARGE T&R | Yes | Call TI | Level-3-250C-168 HR | -40 to 125 | AM2432B SDGHIALX 709 |
| AM2432BSEFHIALVR | Active | Production | FCBGA (ALV) 441 | 500 LARGE T&R | Yes | Call TI | Level-3-250C-168 HR | -40 to 125 | AM2432B SEFHIALV 709 |
| AM2432BSEFHIALVR.B | Active | Production | FCBGA (ALV) 441 | 500 LARGE T&R | Yes | Call TI | Level-3-250C-168 HR | -40 to 125 | AM2432B SEFHIALV 709 |
| AM2432BSEFHIALXR | Active | Production | FCCSP (ALX) 293 | 1000 LARGE T&R | Yes | Call TI | Level-3-250C-168 HR | -40 to 125 | AM2432B SEFHIALX 709 |

| Orderable part number | Status (1) | Material type (2) | Package Pins | Package qty Carrier | RoHS (3) | Lead finish/ Ball material (4) | MSL rating/ Peak reflow (5) | Op temp (°C) | Part marking (6) |
|----------------------------------|---------------|----------------------|-------------------|-----------------------|-------------|--------------------------------------|-----------------------------------|--------------|----------------------------|
| AM2432BSEFHIALXR.B | Active | Production | FCCSP (ALX) 293 | 1000 LARGE T&R | Yes | Call TI | Level-3-250C-168 HR | -40 to 125 | AM2432B SEFHIALX 709 |
| AM2432BSFFHIALVR | Active | Production | FCBGA (ALV) 441 | 500 LARGE T&R | Yes | Call TI | Level-3-250C-168 HR | -40 to 125 | AM2432B SFFHIALV 709 |
| AM2432BSFFHIALVR.B | Active | Production | FCBGA (ALV) 441 | 500 LARGE T&R | Yes | Call TI | Level-3-250C-168 HR | -40 to 125 | AM2432B SFFHIALV 709 |
| AM2432BSFFHIALXR | Active | Production | FCCSP (ALX) 293 | 1000 LARGE T&R | Yes | Call TI | Level-3-250C-168 HR | -40 to 125 | AM2432B SFFHIALX 709 |
| AM2432BSFFHIALXR.B | Active | Production | FCCSP (ALX) 293 | 1000 LARGE T&R | Yes | Call TI | Level-3-250C-168 HR | -40 to 125 | AM2432B SFFHIALX 709 |
| AM2432BSFFHIANIR | Active | Production | FCCSP (ANI) 441 | 1000 LARGE T&R | Yes | Call TI | Level-3-250C-168 HR | -40 to 125 | TI AM243 2BSFFHI |
| AM2434BSDFHIALVR | Active | Production | FCBGA (ALV) 441 | 500 LARGE T&R | Yes | Call TI | Level-3-250C-168 HR | -40 to 125 | AM2434B SDFHIALV 709 |
| AM2434BSDFHIALVR.B | Active | Production | FCBGA (ALV) 441 | 500 LARGE T&R | Yes | Call TI | Level-3-250C-168 HR | -40 to 125 | AM2434B SDFHIALV 709 |
| AM2434BSDFHIALXR | Active | Production | FCCSP (ALX) 293 | 1000 LARGE T&R | Yes | Call TI | Level-3-250C-168 HR | -40 to 125 | AM2434B SDFHIALX 709 |
| AM2434BSDFHIALXR.B | Active | Production | FCCSP (ALX) 293 | 1000 LARGE T&R | Yes | Call TI | Level-3-250C-168 HR | -40 to 125 | AM2434B SDFHIALX 709 |
| AM2434BSDGHIALVR | Active | Production | FCBGA (ALV) 441 | 500 LARGE T&R | Yes | Call TI | Level-3-250C-168 HR | -40 to 125 | AM2434B SDGHIALV 709 |
| AM2434BSDGHIALVR.B | Active | Production | FCBGA (ALV) 441 | 500 LARGE T&R | Yes | Call TI | Level-3-250C-168 HR | -40 to 125 | AM2434B SDGHIALV 709 |

| Orderable part number | Status (1) | Material type (2) | Package Pins | Package qty Carrier | RoHS (3) | Lead finish/ Ball material (4) | MSL rating/ Peak reflow (5) | Op temp (°C) | Part marking (6) |
|----------------------------------|---------------|----------------------|-------------------|-----------------------|-------------|--------------------------------------|-----------------------------------|--------------|----------------------------|
| AM2434BSDGHIALXR | Active | Production | FCCSP (ALX) 293 | 1000 LARGE T&R | Yes | Call TI | Level-3-250C-168 HR | -40 to 125 | AM2434B SDGHIALX 709 |
| AM2434BSDGHIALXR.B | Active | Production | FCCSP (ALX) 293 | 1000 LARGE T&R | Yes | Call TI | Level-3-250C-168 HR | -40 to 125 | AM2434B SDGHIALX 709 |
| AM2434BSEFHIALVR | Active | Production | FCBGA (ALV) 441 | 500 LARGE T&R | Yes | Call TI | Level-3-250C-168 HR | -40 to 125 | AM2434B SEFHIALV 709 |
| AM2434BSEFHIALVR.B | Active | Production | FCBGA (ALV) 441 | 500 LARGE T&R | Yes | Call TI | Level-3-250C-168 HR | -40 to 125 | AM2434B SEFHIALV 709 |
| AM2434BSEFHIALXR | Active | Production | FCCSP (ALX) 293 | 1000 LARGE T&R | Yes | Call TI | Level-3-250C-168 HR | -40 to 125 | AM2434B SEFHIALX 709 |
| AM2434BSEFHIALXR.B | Active | Production | FCCSP (ALX) 293 | 1000 LARGE T&R | Yes | Call TI | Level-3-250C-168 HR | -40 to 125 | AM2434B SEFHIALX 709 |
| AM2434BSFFHIALVR | Active | Production | FCBGA (ALV) 441 | 500 LARGE T&R | Yes | Call TI | Level-3-250C-168 HR | -40 to 125 | AM2434B SFFHIALV 709 |
| AM2434BSFFHIALVR.B | Active | Production | FCBGA (ALV) 441 | 500 LARGE T&R | Yes | Call TI | Level-3-250C-168 HR | -40 to 125 | AM2434B SFFHIALV 709 |
| AM2434BSFFHIALXR | Active | Production | FCCSP (ALX) 293 | 1000 LARGE T&R | Yes | Call TI | Level-3-250C-168 HR | -40 to 125 | AM2434B SFFHIALX 709 |
| AM2434BSFFHIALXR.B | Active | Production | FCCSP (ALX) 293 | 1000 LARGE T&R | Yes | Call TI | Level-3-250C-168 HR | -40 to 125 | AM2434B SFFHIALX 709 |
| AM2434BSFFHIANIR | Active | Production | FCCSP (ANI) 441 | 1000 LARGE T&R | Yes | Call TI | Level-3-250C-168 HR | -40 to 125 | TI AM243 4BSFFHI |

⁽¹⁾ **Status:** For more details on status, see our [product life cycle](#).

- (2) **Material type:** When designated, preproduction parts are prototypes/experimental devices, and are not yet approved or released for full production. Testing and final process, including without limitation quality assurance, reliability performance testing, and/or process qualification, may not yet be complete, and this item is subject to further changes or possible discontinuation. If available for ordering, purchases will be subject to an additional waiver at checkout, and are intended for early internal evaluation purposes only. These items are sold without warranties of any kind.
- (3) **RoHS values:** Yes, No, RoHS Exempt. See the [TI RoHS Statement](#) for additional information and value definition.
- (4) **Lead finish/Ball material:** Parts may have multiple material finish options. Finish options are separated by a vertical ruled line. Lead finish/Ball material values may wrap to two lines if the finish value exceeds the maximum column width.
- (5) **MSL rating/Peak reflow:** The moisture sensitivity level ratings and peak solder (reflow) temperatures. In the event that a part has multiple moisture sensitivity ratings, only the lowest level per JEDEC standards is shown. Refer to the shipping label for the actual reflow temperature that will be used to mount the part to the printed circuit board.
- (6) **Part marking:** There may be an additional marking, which relates to the logo, the lot trace code information, or the environmental category of the part.

Multiple part markings will be inside parentheses. Only one part marking contained in parentheses and separated by a "~" will appear on a part. If a line is indented then it is a continuation of the previous line and the two combined represent the entire part marking for that device.

Important Information and Disclaimer: The information provided on this page represents TI's knowledge and belief as of the date that it is provided. TI bases its knowledge and belief on information provided by third parties, and makes no representation or warranty as to the accuracy of such information. Efforts are underway to better integrate information from third parties. TI has taken and continues to take reasonable steps to provide representative and accurate information but may not have conducted destructive testing or chemical analysis on incoming materials and chemicals. TI and TI suppliers consider certain information to be proprietary, and thus CAS numbers and other limited information may not be available for release.

In no event shall TI's liability arising out of such information exceed the total purchase price of the TI part(s) at issue in this document sold by TI to Customer on an annual basis.

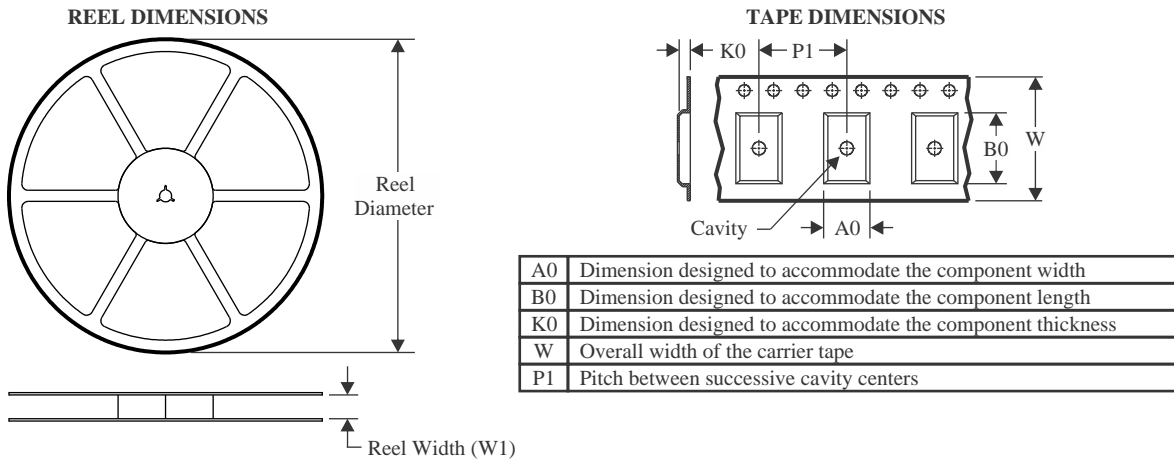
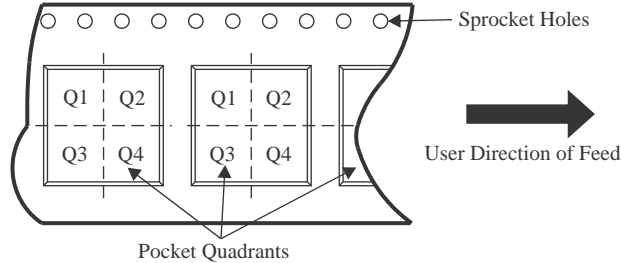
TAPE AND REEL INFORMATION

QUADRANT ASSIGNMENTS FOR PIN 1 ORIENTATION IN TAPE

*All dimensions are nominal

| Device | Package Type | Package Drawing | Pins | SPQ | Reel Diameter (mm) | Reel Width W1 (mm) | A0 (mm) | B0 (mm) | K0 (mm) | P1 (mm) | W (mm) | Pin1 Quadrant |
|------------------|--------------|-----------------|------|------|--------------------|--------------------|---------|---------|---------|---------|--------|---------------|
| AM2431BSDLFIALVR | FCBGA | ALV | 441 | 500 | 330.0 | 32.4 | 17.6 | 17.6 | 3.74 | 24.0 | 32.0 | Q1 |
| AM2431BSDLFIALXR | FCCSP | ALX | 293 | 1000 | 330.0 | 24.4 | 11.4 | 11.4 | 1.75 | 16.0 | 24.0 | Q1 |
| AM2431BSDGHIALVR | FCBGA | ALV | 441 | 500 | 330.0 | 32.4 | 17.6 | 17.6 | 3.74 | 24.0 | 32.0 | Q1 |
| AM2431BSDGHIALXR | FCCSP | ALX | 293 | 1000 | 330.0 | 24.4 | 11.4 | 11.4 | 1.75 | 16.0 | 24.0 | Q1 |
| AM2432BKEGHIALXR | FCCSP | ALX | 293 | 1000 | 330.0 | 24.4 | 11.4 | 11.4 | 1.75 | 16.0 | 24.0 | Q1 |
| AM2432BKFGHIALXR | FCCSP | ALX | 293 | 1000 | 330.0 | 24.4 | 11.4 | 11.4 | 1.75 | 16.0 | 24.0 | Q1 |
| AM2432BSDLFIALVR | FCBGA | ALV | 441 | 500 | 330.0 | 32.4 | 17.6 | 17.6 | 3.74 | 24.0 | 32.0 | Q1 |
| AM2432BSDLFIALXR | FCCSP | ALX | 293 | 1000 | 330.0 | 24.4 | 11.4 | 11.4 | 1.75 | 16.0 | 24.0 | Q1 |
| AM2432BSDGHIALVR | FCBGA | ALV | 441 | 500 | 330.0 | 32.4 | 17.6 | 17.6 | 3.74 | 24.0 | 32.0 | Q1 |
| AM2432BSDGHIALXR | FCCSP | ALX | 293 | 1000 | 330.0 | 24.4 | 11.4 | 11.4 | 1.75 | 16.0 | 24.0 | Q1 |
| AM2432BSEFIALVR | FCBGA | ALV | 441 | 500 | 330.0 | 32.4 | 17.6 | 17.6 | 3.74 | 24.0 | 32.0 | Q1 |
| AM2432BSEFIALXR | FCCSP | ALX | 293 | 1000 | 330.0 | 24.4 | 11.4 | 11.4 | 1.75 | 16.0 | 24.0 | Q1 |
| AM2432BSFFIALVR | FCBGA | ALV | 441 | 500 | 330.0 | 32.4 | 17.6 | 17.6 | 3.74 | 24.0 | 32.0 | Q1 |
| AM2432BSFFIALXR | FCCSP | ALX | 293 | 1000 | 330.0 | 24.4 | 11.4 | 11.4 | 1.75 | 16.0 | 24.0 | Q1 |
| AM2434BSDLFIALVR | FCBGA | ALV | 441 | 500 | 330.0 | 32.4 | 17.6 | 17.6 | 3.74 | 24.0 | 32.0 | Q1 |
| AM2434BSDLFIALXR | FCCSP | ALX | 293 | 1000 | 330.0 | 24.4 | 11.4 | 11.4 | 1.75 | 16.0 | 24.0 | Q1 |

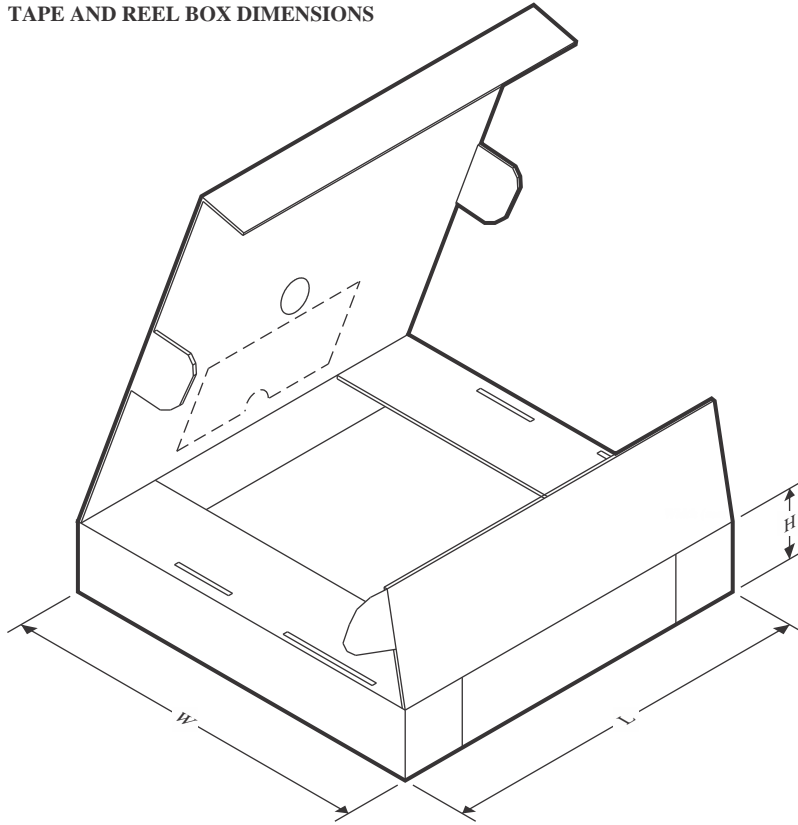
| Device | Package Type | Package Drawing | Pins | SPQ | Reel Diameter (mm) | Reel Width W1 (mm) | A0 (mm) | B0 (mm) | K0 (mm) | P1 (mm) | W (mm) | Pin1 Quadrant |
|------------------|--------------|-----------------|------|------|--------------------|--------------------|---------|---------|---------|---------|--------|---------------|
| AM2434BSDGHIALVR | FCBGA | ALV | 441 | 500 | 330.0 | 32.4 | 17.6 | 17.6 | 3.74 | 24.0 | 32.0 | Q1 |
| AM2434BSDGHIALXR | FCCSP | ALX | 293 | 1000 | 330.0 | 24.4 | 11.4 | 11.4 | 1.75 | 16.0 | 24.0 | Q1 |
| AM2434BSEFHIALVR | FCBGA | ALV | 441 | 500 | 330.0 | 32.4 | 17.6 | 17.6 | 3.74 | 24.0 | 32.0 | Q1 |
| AM2434BSEFHIALXR | FCCSP | ALX | 293 | 1000 | 330.0 | 24.4 | 11.4 | 11.4 | 1.75 | 16.0 | 24.0 | Q1 |
| AM2434BSFFHIALVR | FCBGA | ALV | 441 | 500 | 330.0 | 32.4 | 17.6 | 17.6 | 3.74 | 24.0 | 32.0 | Q1 |
| AM2434BSFFHIALXR | FCCSP | ALX | 293 | 1000 | 330.0 | 24.4 | 11.4 | 11.4 | 1.75 | 16.0 | 24.0 | Q1 |

TAPE AND REEL BOX DIMENSIONS

*All dimensions are nominal

| Device | Package Type | Package Drawing | Pins | SPQ | Length (mm) | Width (mm) | Height (mm) |
|------------------|--------------|-----------------|------|------|-------------|------------|-------------|
| AM2431BPDFHIALVR | FCBGA | ALV | 441 | 500 | 336.6 | 336.6 | 41.3 |
| AM2431BPDFHIALXR | FCCSP | ALX | 293 | 1000 | 336.6 | 336.6 | 41.3 |
| AM2431BSDGHIALVR | FCBGA | ALV | 441 | 500 | 336.6 | 336.6 | 41.3 |
| AM2431BSDGHIALXR | FCCSP | ALX | 293 | 1000 | 336.6 | 336.6 | 41.3 |
| AM2432BKFGHIALXR | FCCSP | ALX | 293 | 1000 | 336.6 | 336.6 | 41.3 |
| AM2432BKFGHIALXR | FCCSP | ALX | 293 | 1000 | 336.6 | 336.6 | 41.3 |
| AM2432BPDFHIALVR | FCBGA | ALV | 441 | 500 | 336.6 | 336.6 | 41.3 |
| AM2432BPDFHIALXR | FCCSP | ALX | 293 | 1000 | 336.6 | 336.6 | 41.3 |
| AM2432BSDGHIALVR | FCBGA | ALV | 441 | 500 | 336.6 | 336.6 | 41.3 |
| AM2432BSDGHIALXR | FCCSP | ALX | 293 | 1000 | 336.6 | 336.6 | 41.3 |
| AM2432BSEFHIALVR | FCBGA | ALV | 441 | 500 | 336.6 | 336.6 | 41.3 |
| AM2432BSEFHIALXR | FCCSP | ALX | 293 | 1000 | 336.6 | 336.6 | 41.3 |
| AM2432BSFFHIALVR | FCBGA | ALV | 441 | 500 | 336.6 | 336.6 | 41.3 |
| AM2432BSFFHIALXR | FCCSP | ALX | 293 | 1000 | 336.6 | 336.6 | 41.3 |
| AM2434BPDFHIALVR | FCBGA | ALV | 441 | 500 | 336.6 | 336.6 | 41.3 |
| AM2434BPDFHIALXR | FCCSP | ALX | 293 | 1000 | 336.6 | 336.6 | 41.3 |
| AM2434BSDGHIALVR | FCBGA | ALV | 441 | 500 | 336.6 | 336.6 | 41.3 |
| AM2434BSDGHIALXR | FCCSP | ALX | 293 | 1000 | 336.6 | 336.6 | 41.3 |

| Device | Package Type | Package Drawing | Pins | SPQ | Length (mm) | Width (mm) | Height (mm) |
|------------------|--------------|-----------------|------|------|-------------|------------|-------------|
| AM2434BSEFHIALVR | FCBGA | ALV | 441 | 500 | 336.6 | 336.6 | 41.3 |
| AM2434BSEFHIALXR | FCCSP | ALX | 293 | 1000 | 336.6 | 336.6 | 41.3 |
| AM2434BSFFHIALVR | FCBGA | ALV | 441 | 500 | 336.6 | 336.6 | 41.3 |
| AM2434BSFFHIALXR | FCCSP | ALX | 293 | 1000 | 336.6 | 336.6 | 41.3 |

ALX0293A

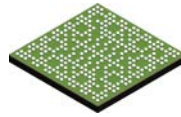

PACKAGE OUTLINE

FCCSP - 1 mm max height

PLASTIC BALL GRID ARRAY

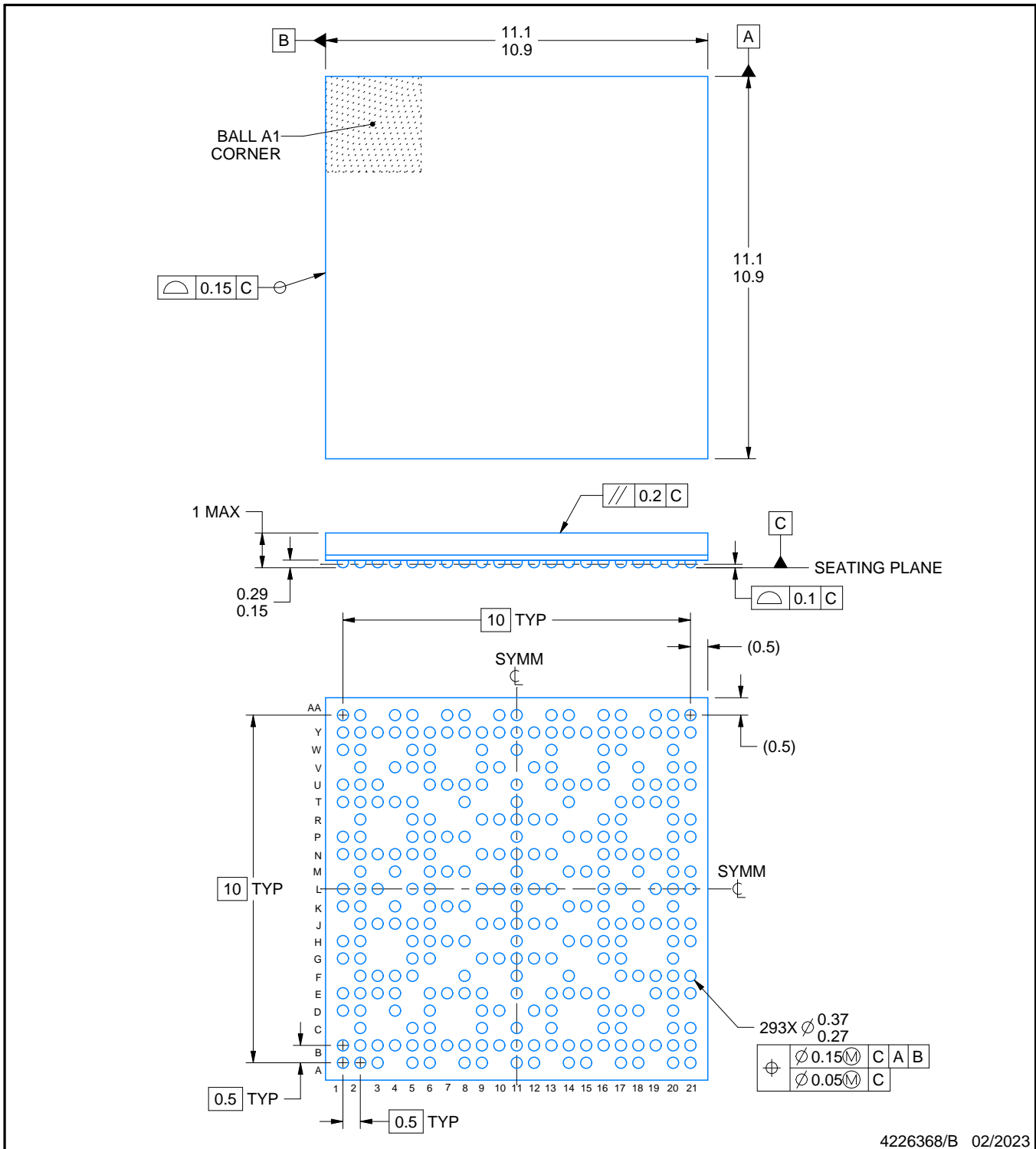

NOTES:

1. All linear dimensions are in millimeters. Any dimensions in parenthesis are for reference only. Dimensioning and tolerancing per ASME Y14.5M.
2. This drawing is subject to change without notice.

EXAMPLE BOARD LAYOUT

ALX0293A

FCCSP - 1 mm max height

PLASTIC BALL GRID ARRAY

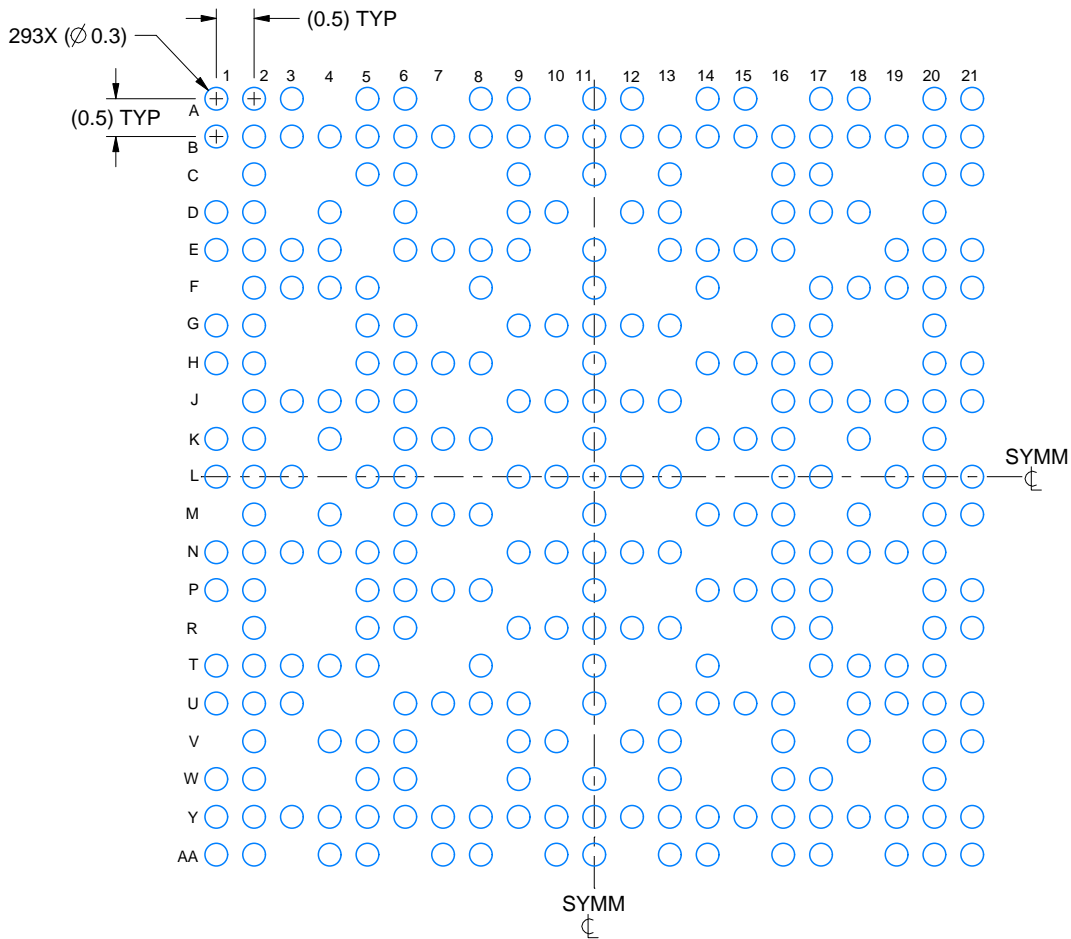

LAND PATTERN EXAMPLE

EXPOSED METAL SHOWN
SCALE: 10X

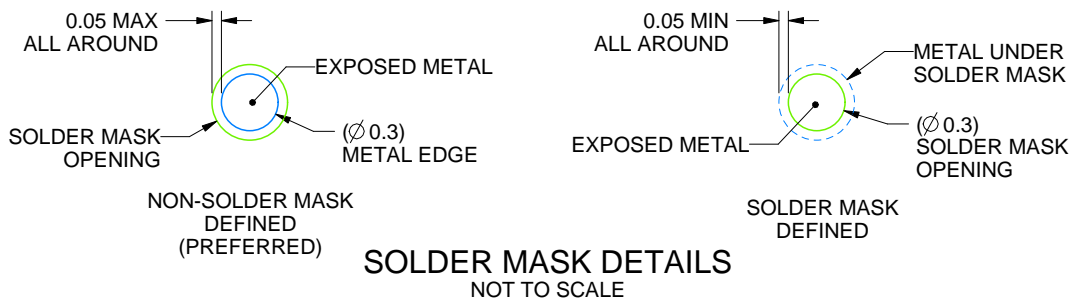

4226368/B 02/2023

NOTES: (continued)

- Final dimensions may vary due to manufacturing tolerance considerations and also routing constraints. For information, see Texas Instruments literature number SPRAA99 (www.ti.com/lit/spraa99).

EXAMPLE STENCIL DESIGN

ALX0293A

FCCSP - 1 mm max height

PLASTIC BALL GRID ARRAY

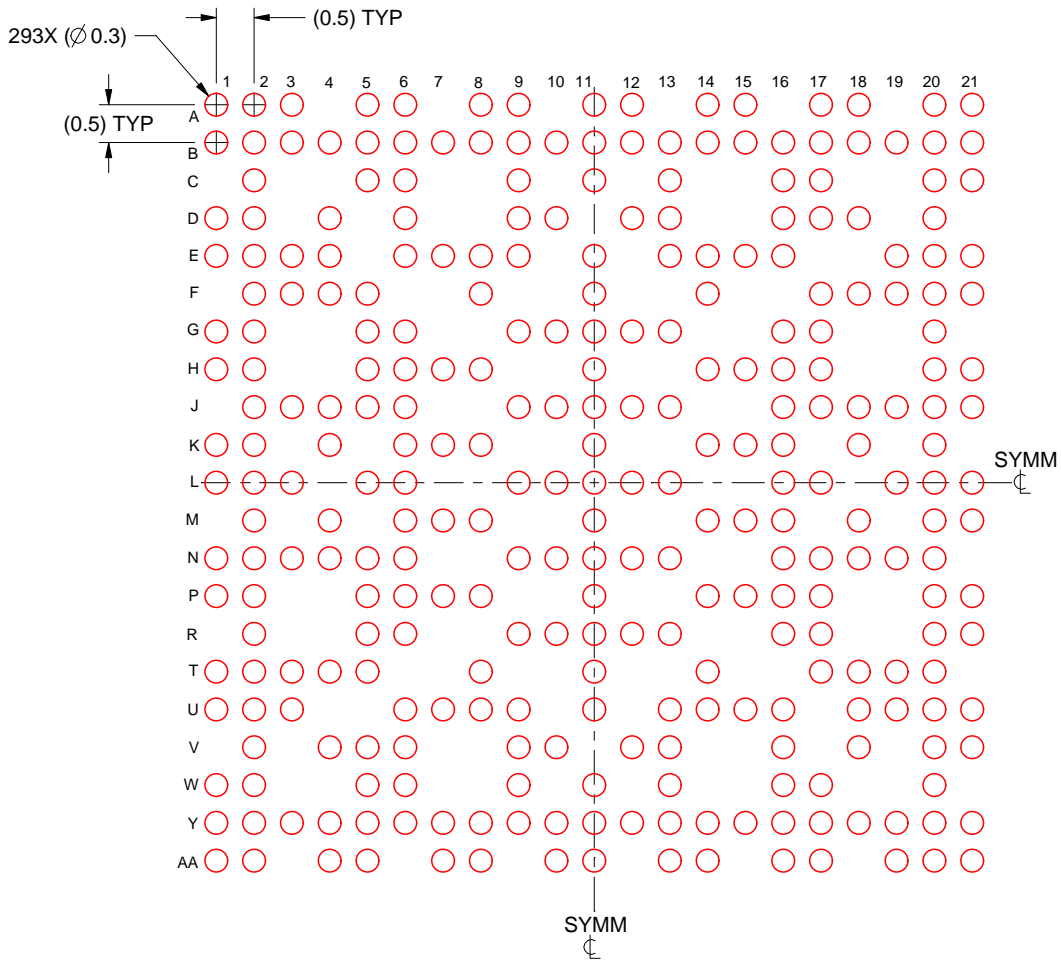

SOLDER PASTE EXAMPLE
BASED ON 0.125 mm THICK STENCIL
SCALE: 10X

4226368/B 02/2023

NOTES: (continued)

4. Laser cutting apertures with trapezoidal walls and rounded corners may offer better paste release.

ALV0441A

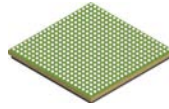

PACKAGE OUTLINE

FCBGA - 2.657 mm max height

BALL GRID ARRAY

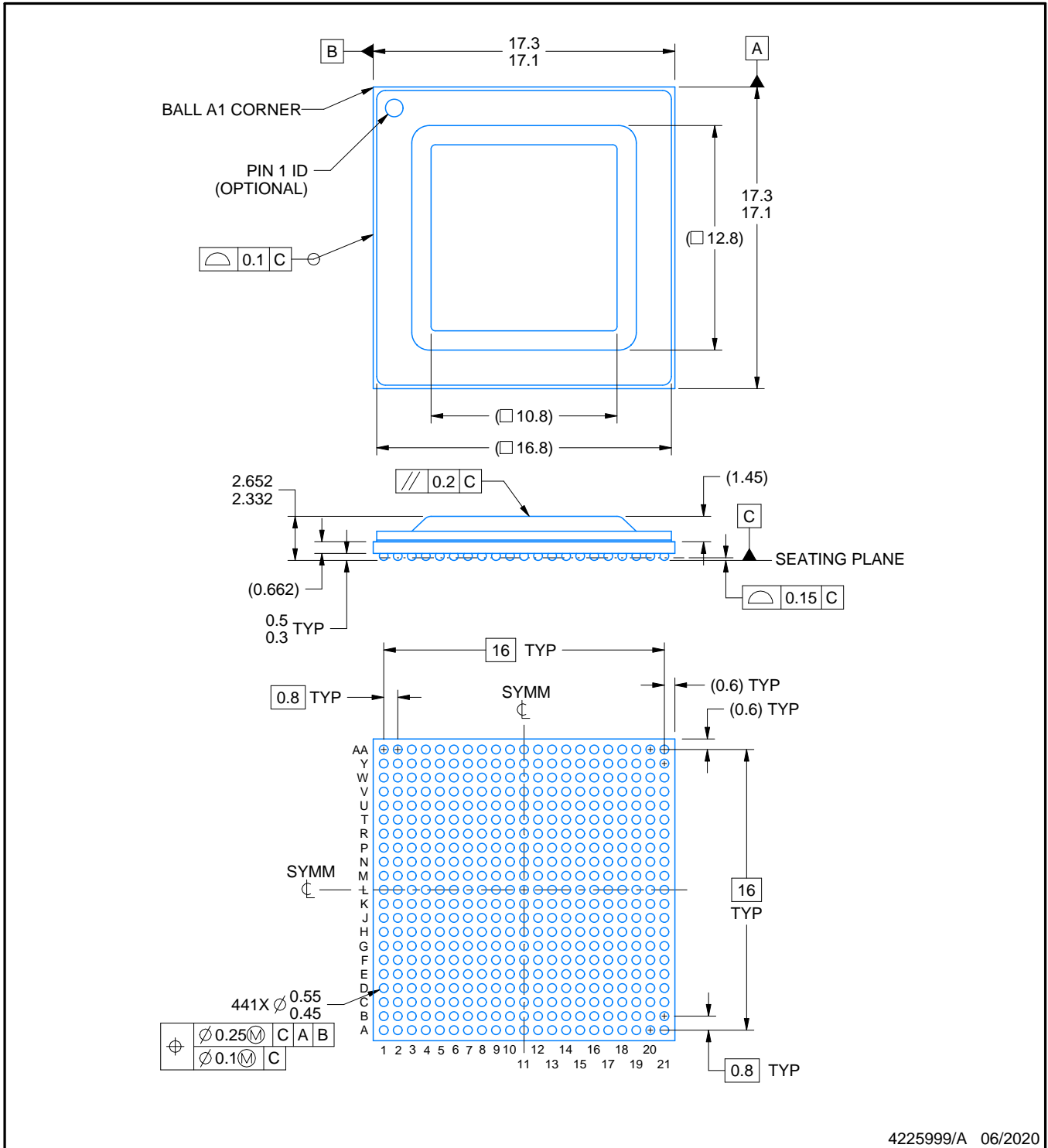

4225999/A 06/2020

NOTES:

1. All linear dimensions are in millimeters. Any dimensions in parenthesis are for reference only. Dimensioning and tolerancing per ASME Y14.5M.
2. This drawing is subject to change without notice.

EXAMPLE BOARD LAYOUT

ALV0441A

FCBGA - 2.657 mm max height

BALL GRID ARRAY

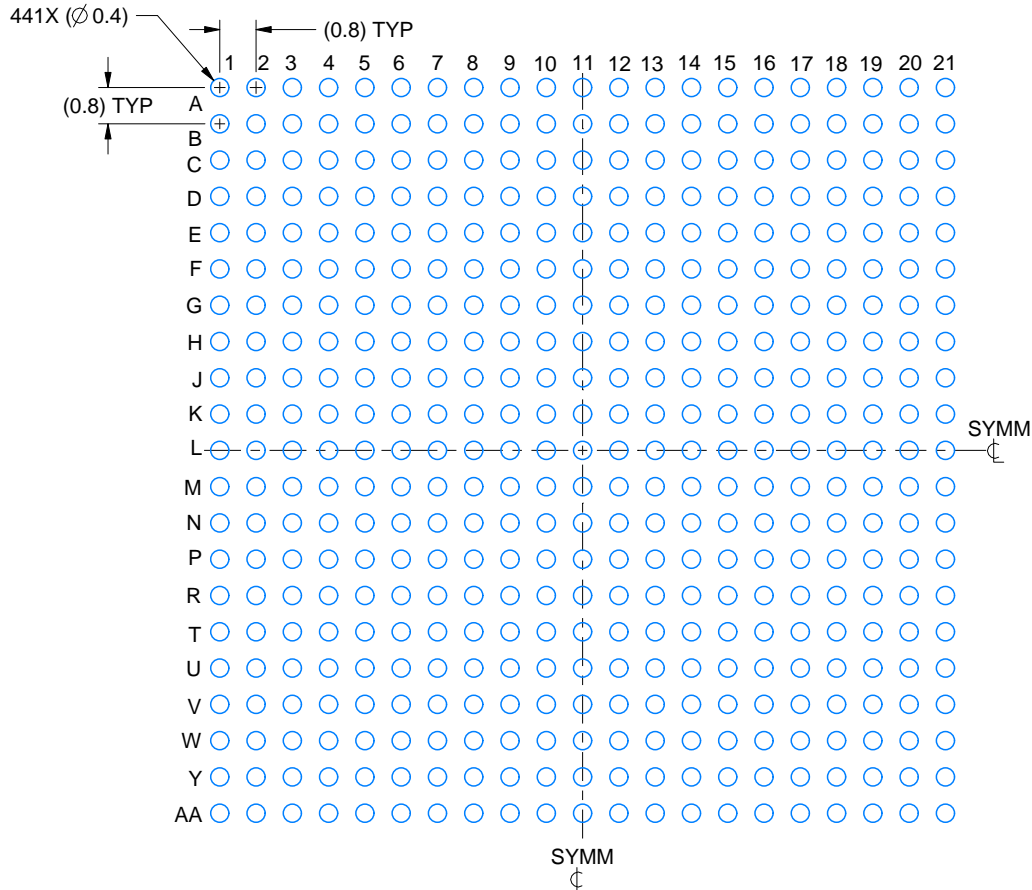

LAND PATTERN EXAMPLE
EXPOSED METAL SHOWN
SCALE:6X

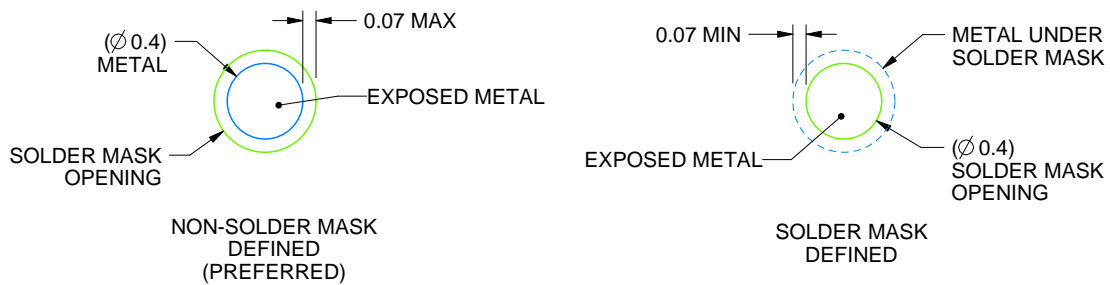

SOLDER MASK DETAILS
NOT TO SCALE

4225999/A 06/2020

NOTES: (continued)

- Final dimensions may vary due to manufacturing tolerance considerations and also routing constraints. For more information, see Texas Instruments literature number SPRU811 (www.ti.com/lit/spru811).

EXAMPLE STENCIL DESIGN

ALV0441A

FCBGA - 2.657 mm max height

BALL GRID ARRAY

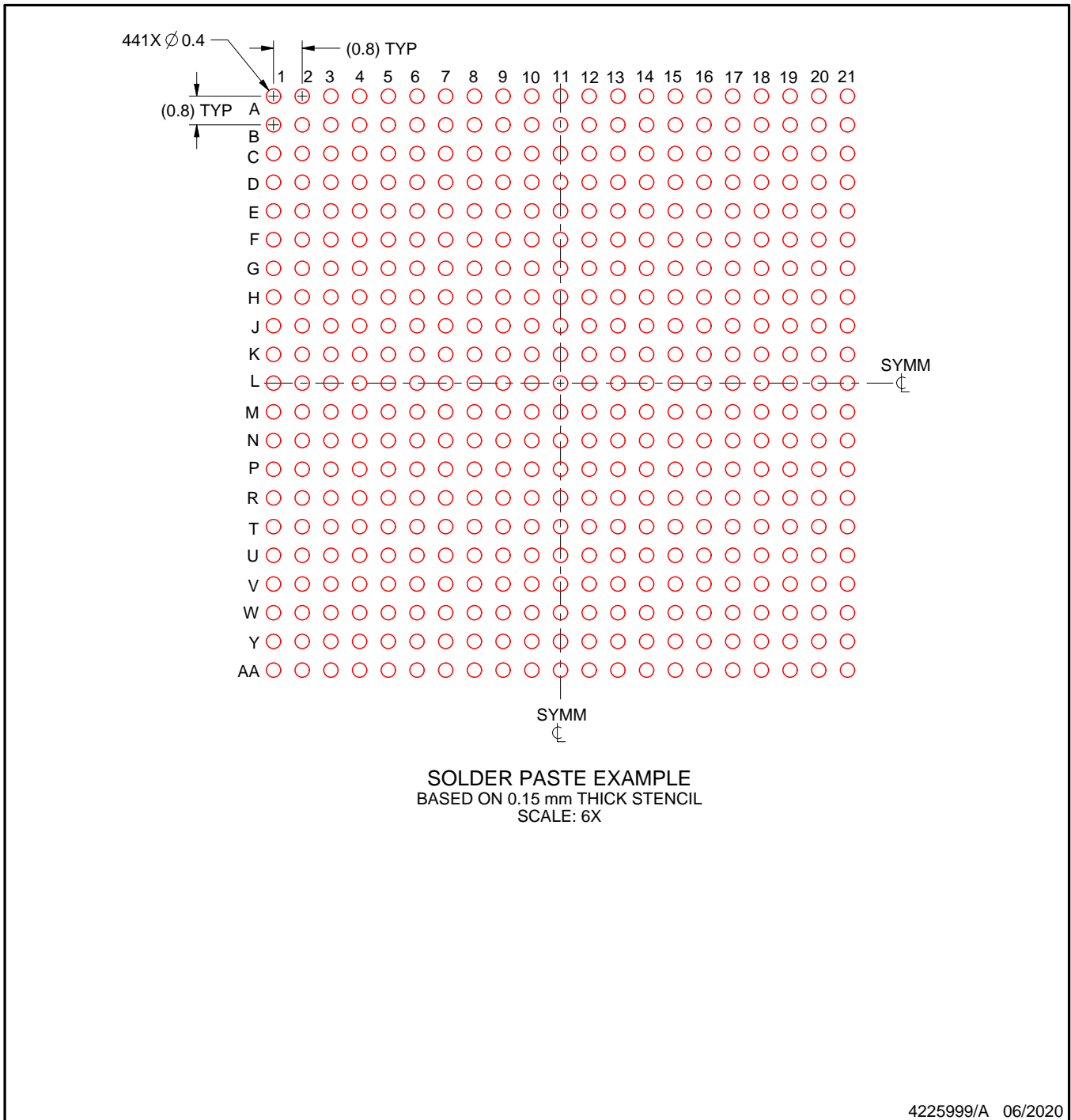

NOTES: (continued)

4. Laser cutting apertures with trapezoidal walls and rounded corners may offer better paste release.

IMPORTANT NOTICE AND DISCLAIMER

TI PROVIDES TECHNICAL AND RELIABILITY DATA (INCLUDING DATASHEETS), DESIGN RESOURCES (INCLUDING REFERENCE DESIGNS), APPLICATION OR OTHER DESIGN ADVICE, WEB TOOLS, SAFETY INFORMATION, AND OTHER RESOURCES "AS IS" AND WITH ALL FAULTS, AND DISCLAIMS ALL WARRANTIES, EXPRESS AND IMPLIED, INCLUDING WITHOUT LIMITATION ANY IMPLIED WARRANTIES OF MERCHANTABILITY, FITNESS FOR A PARTICULAR PURPOSE OR NON-INFRINGEMENT OF THIRD PARTY INTELLECTUAL PROPERTY RIGHTS.

These resources are intended for skilled developers designing with TI products. You are solely responsible for (1) selecting the appropriate TI products for your application, (2) designing, validating and testing your application, and (3) ensuring your application meets applicable standards, and any other safety, security, regulatory or other requirements.

These resources are subject to change without notice. TI grants you permission to use these resources only for development of an application that uses the TI products described in the resource. Other reproduction and display of these resources is prohibited. No license is granted to any other TI intellectual property right or to any third party intellectual property right. TI disclaims responsibility for, and you fully indemnify TI and its representatives against any claims, damages, costs, losses, and liabilities arising out of your use of these resources.

TI's products are provided subject to [TI's Terms of Sale](#), [TI's General Quality Guidelines](#), or other applicable terms available either on ti.com or provided in conjunction with such TI products. TI's provision of these resources does not expand or otherwise alter TI's applicable warranties or warranty disclaimers for TI products. Unless TI explicitly designates a product as custom or customer-specified, TI products are standard, catalog, general purpose devices.

TI objects to and rejects any additional or different terms you may propose.

Copyright © 2026, Texas Instruments Incorporated

Last updated 10/2025