

TLV61046A 28-V Output Voltage Boost Converter with Power Diode and Isolation Switch

1 Features

- Input voltage range: 1.8 V to 5.5 V, down to 1.6 V after start-up
- Output voltage up to 28 V
- Integrated power diode and isolation switch
- 980-mA (typical) switch current
- Up to 85% efficiency at 3.6-V input and 12-V output
- $\pm 2.5\%$ output voltage accuracy
- Power save operation mode at light load
- Internal 7-ms soft start time
- True disconnection between input and output during shutdown
- Output short circuit protection
- Output overvoltage protection
- Thermal shutdown protection
- 3-mm \times 3-mm SOT23-6 package
- Create a custom design using the TLV61046A with the [WEBENCH® Power Designer](#)

2 Applications

- PMOLED power supply
- LCD panel
- [Wearable devices](#)
- [Portable medical equipment](#)
- Sensor power supply

3 Description

The TLV61046A is a highly-integrated boost converter designed for applications such as PMOLED panel, LCD bias supply, and sensor module. The TLV61046A integrates a 30-V power switch, an input to output isolation switch, and a rectifier diode. It can output up to 28 V from input of a Li+ battery or two alkaline batteries in series.

The TLV61046A operates with a switching frequency at 1.0 MHz. This allows the use of small external components. The TLV61046A has an internal default 12-V output voltage setting by connecting the FB pin to the VIN pin. Thus it only needs three external components to get 12-V output voltage. The TLV61046A has typical 980-mA switch current limit. It has 7-ms built-in soft start time to reduce the inrush current. When the TLV61046A is in shutdown mode, the isolation switch disconnects the output from input to minimize the leakage current. The TLV61046A also implements output short circuit protection, output overvoltage protection, and thermal shutdown.

The TLV61046A is available in a 6-pin 3-mm x 3-mm SOT23-6 package.

Device Information (1)

PART NUMBER	PACKAGE	BODY SIZE (NOM)
TLV61046A	SOT23-6 (6)	2.9 mm x 1.6 mm

(1) For all available packages, see the orderable addendum at the end of the data sheet.

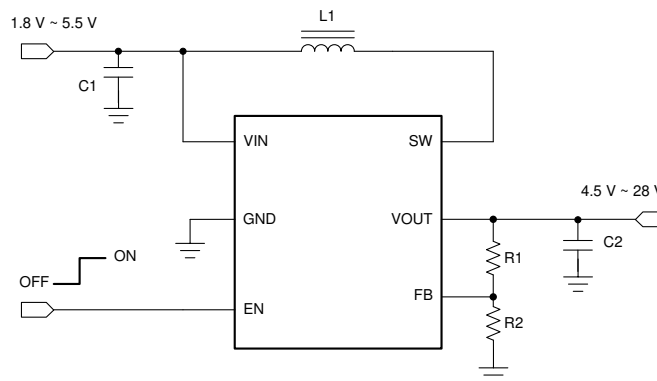

Simplified Schematic



Table of Contents

1 Features	1	8 Application and Implementation	11
2 Applications	1	8.1 Application Information.....	11
3 Description	1	8.2 Typical Application - 12-V Output Boost Converter...	11
4 Revision History	2	8.3 System Examples.....	16
5 Pin Configuration and Functions	3	9 Power Supply Recommendations	17
6 Specifications	4	10 Layout	18
6.1 Absolute Maximum Ratings.....	4	10.1 Layout Guidelines.....	18
6.2 ESD Ratings.....	4	10.2 Layout Example.....	18
6.3 Recommended Operating Conditions.....	4	11 Device and Documentation Support	19
6.4 Thermal Information.....	4	11.1 Device Support.....	19
6.5 Electrical Characteristics.....	5	11.2 Receiving Notification of Documentation Updates..	19
6.6 Typical Characteristics.....	6	11.3 Support Resources.....	19
7 Detailed Description	8	11.4 Trademarks.....	19
7.1 Overview.....	8	11.5 Electrostatic Discharge Caution.....	19
7.2 Functional Block Diagram.....	8	11.6 Glossary.....	19
7.3 Feature Description.....	8	12 Mechanical, Packaging, and Orderable Information	20
7.4 Device Functional Modes.....	9		

4 Revision History

Changes from Revision A (April 2017) to Revision B (February 2021)	Page
• Updated the numbering format for tables, figures and cross-references throughout the document.	1
• Corrected grammar and numeration format	1
• Added WEBENCH links	1

Changes from Revision * (April 2017) to Revision A (April 2017)	Page
• Changed to Production Data.....	1

5 Pin Configuration and Functions

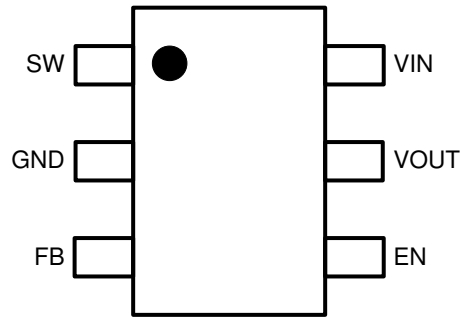

Figure 5-1. DBV Package 6-Pin SOT23 Top View

Table 5-1. Pin Functions

PIN		TYPE	DESCRIPTION
NAME	NUMBER		
SW	1	PWR	The switch pin of the converter. It is connected to the drain of the internal power MOSFET.
GND	2	PWR	Ground
FB	3	I	Voltage feedback of adjustable output voltage. Connected to the center tap of a resistor divider to program the output voltage. When it is connected to the VIN pin, the output voltage is set to 12 V by an internal feedback.
EN	4	I	Enable logic input. Logic high voltage enables the device. Logic low voltage disables the device and turns it into shutdown mode.
VOUT	5	PWR	Output of the boost converter
VIN	6	I	IC power supply input

6 Specifications

6.1 Absolute Maximum Ratings

over operating free-air temperature range (unless otherwise noted) ⁽¹⁾

		MIN	MAX	UNIT
Voltage range at terminals ⁽²⁾	VIN, EN, FB	–0.3	6	V
	SW, VOUT	–0.3	32	V
Operating junction temperature range, T _J		–40	150	°C
Storage temperature range, T _{stg}		–65	150	°C

- (1) Stresses beyond those listed under *Absolute Maximum Ratings* may cause permanent damage to the device. These are stress ratings only, which do not imply functional operation of the device at these or any other conditions beyond those indicated under *Recommended Operating Conditions*. Exposure to absolute-maximum-rated conditions for extended periods may affect device reliability.
- (2) All voltage values are with respect to network ground terminal.

6.2 ESD Ratings

			VALUE	UNIT
V _(ESD) ⁽¹⁾	Electrostatic discharge	Human body model (HBM), per ANSI/ESDA/JEDEC JS-001, all pins ⁽²⁾	±2000	V
		Charged device model (CDM), per JEDEC specification JESD22-C101, all pins ⁽³⁾	±500	V

- (1) Electrostatic discharge (ESD) to measure device sensitivity and immunity to damage caused by assembly line electrostatic discharges in to the device.
- (2) JEDEC document JEP155 states that 500-V HBM allows safe manufacturing with a standard ESD control process.
- (3) JEDEC document JEP157 states that 250-V CDM allows safe manufacturing with a standard ESD control process.

6.3 Recommended Operating Conditions

over operating free-air temperature range (unless otherwise noted)

		MIN	TYP	MAX	UNIT
V _{IN}	Input voltage range	1.8		5.5	V
V _{OUT}	Output voltage range	3.3		28	V
L	Effective inductance range	2.2×0.7	10	22×1.3	μH
C _{IN}	Effective input capacitance range	0.22	1.0		μF
C _{OUT}	Effective output capacitance range	0.22	1.0	10	μF
T _J	Operating junction temperature	–40		125	°C

6.4 Thermal Information

THERMAL METRIC ⁽¹⁾		TLV61046A	UNIT
		DBV (SOT23)	
		6 PINS	
R _{θJA}	Junction-to-ambient thermal resistance	177.7	°C/W
R _{θJC(top)}	Junction-to-case (top) thermal resistance	120.6	
R _{θJB}	Junction-to-board thermal resistance	33.2	
Ψ _{JT}	Junction-to-top characterization parameter	21.5	
Ψ _{JB}	Junction-to-board characterization parameter	32.6	
R _{θJC(bot)}	Junction-to-case (bottom) thermal resistance	n/a	

- (1) For more information about traditional and new thermal metrics, see the [Semiconductor and IC Package Thermal Metrics](#) application report.

6.5 Electrical Characteristics

$T_A = -40^\circ\text{C}$ to 85°C , $V_{IN} = 3.6\text{ V}$ and $V_{OUT} = 12\text{ V}$. Typical values are at $T_A = 25^\circ\text{C}$, unless otherwise noted.

PARAMETER		TEST CONDITIONS	MIN	TYP	MAX	UNIT
POWER SUPPLY						
V_{IN}	Input voltage range		1.8		5.5	V
V_{IN_UVLO}	Under voltage lockout threshold	V_{IN} rising		1.75	1.8	V
		V_{IN} falling		1.55	1.6	
V_{IN_HYS}	VIN UVLO hysteresis			200		mV
I_{Q_VIN}	Quiescent current into VIN pin	IC enabled, no load, no switching, $V_{IN} = 1.8\text{ V}$ to 5.5 V , $V_{OUT} = 12\text{ V}$		110	200	μA
I_{SD}	Shutdown current into VIN pin	IC disabled, $V_{IN} = 1.8\text{ V}$ to 5.5 V , $T_A = 25^\circ\text{C}$		0.1	1.0	μA
OUTPUT						
V_{OUT}	Output voltage range		3.3		28	V
V_{OUT_12V}	12-V output voltage accuracy	FB pin connected to VIN pin, $T_J = 0^\circ\text{C}$ to 125°C	11.7	12.1	12.4	V
V_{REF}	Feedback voltage	PWM mode, $T_A = 25^\circ\text{C}$	0.783	0.795	0.807	V
		PWM mode, $T_J = -40^\circ\text{C}$ to 125°C	0.775	0.795	0.815	V
		PFM mode, $T_A = 25^\circ\text{C}$		0.803		V
V_{OVP}	Output overvoltage protection threshold		28	29.2	30.4	V
V_{OVP_HYS}	Over voltage protection hysteresis			0.9		V
I_{FB_LKG}	Leakage current into FB pin	$T_A = 25^\circ\text{C}$			200	nA
I_{SW_LKG}	Leakage current into SW pin	IC disabled, $T_A = 25^\circ\text{C}$			500	nA
POWER SWITCH						
$R_{DS(on)}$	Isolation MOSFET on resistance	$V_{OUT} = 12\text{ V}$		850		m Ω
	Low-side MOSFET on resistance	$V_{OUT} = 12\text{ V}$		450		
f_{SW}	Switching frequency	$V_{IN} = 3.6\text{ V}$, $V_{OUT} = 12\text{ V}$, PWM mode	850	1050	1250	kHz
t_{ON_min}	Minimal switch on time			150	250	ns
I_{LIM_SW}	Peak switch current limit	$V_{IN} = 3.6\text{ V}$, $V_{OUT} = 12\text{ V}$	680	980	1250	mA
		$V_{IN} = 2.4\text{ V}$, $V_{OUT} = 3.3\text{ V}$	20			
I_{LIM_CHG}	Pre-charge current	$V_{IN} = 3.6\text{ V}$, $V_{OUT} = 0\text{ V}$		30	50	mA
$t_{STARTUP}$	Startup time	V_{OUT} from V_{IN} to 12 V , $C_{OUT_effective} = 2.2\text{ }\mu\text{F}$, $I_{OUT} = 0\text{ A}$	2	5		ms
LOGIC INTERFACE						
V_{EN_H}	EN Logic high threshold				1.2	V
V_{EN_L}	EN Logic Low threshold		0.4			V
PROTECTION						
T_{SD}	Thermal shutdown threshold	T_J rising		150		$^\circ\text{C}$
T_{SD_HYS}	Thermal shutdown hysteresis	T_J falling below T_{SD}		20		$^\circ\text{C}$

6.6 Typical Characteristics

$V_{IN} = 3.6\text{ V}$, $V_{OUT} = 12\text{ V}$, $T_A = 25^\circ\text{C}$, unless otherwise noted.

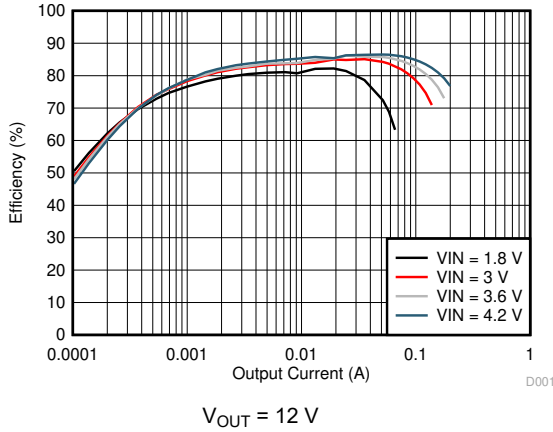

Figure 6-1. Efficiency vs Output Current

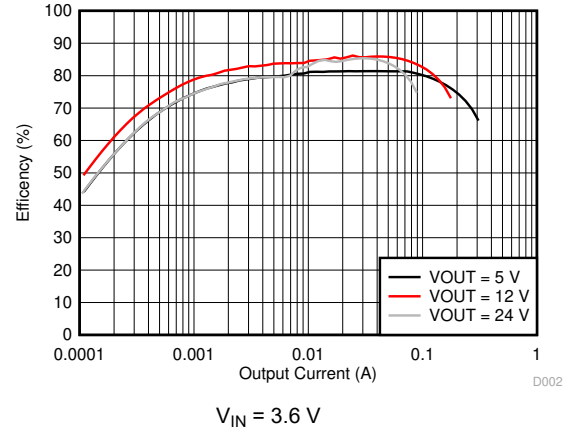

Figure 6-2. Efficiency vs Output Current

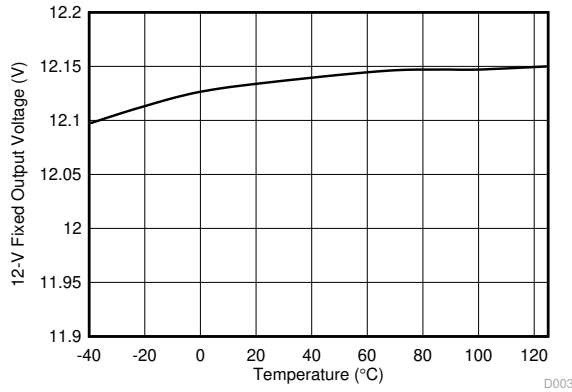

Figure 6-3. 12-V Fixed Output Voltage vs Temperature

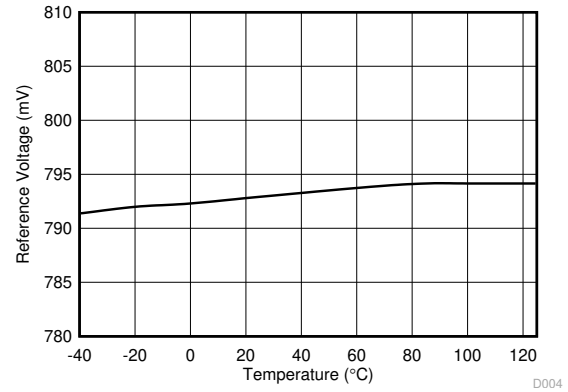

Figure 6-4. FB Reference Voltage vs Temperature

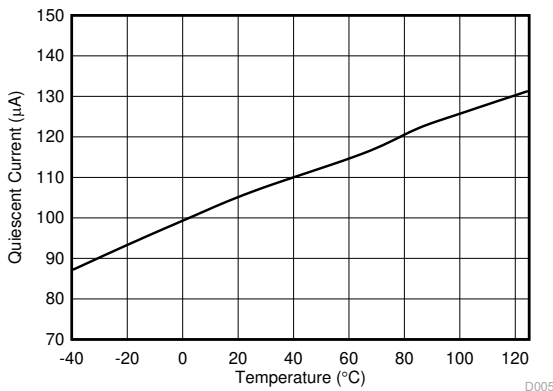

Figure 6-5. Quiescent Current into VIN vs Temperature

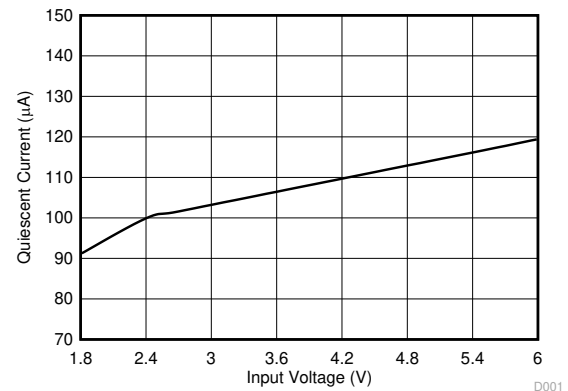

Figure 6-6. Quiescent Current into VIN vs Input Voltage

6.6 Typical Characteristics (continued)

$V_{IN} = 3.6\text{ V}$, $V_{OUT} = 12\text{ V}$, $T_A = 25^\circ\text{C}$, unless otherwise noted.

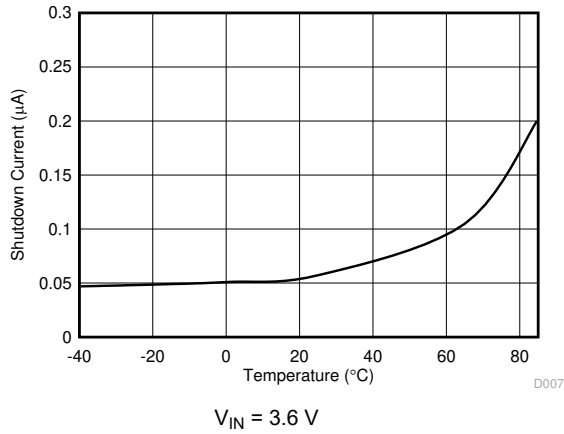

Figure 6-7. Shutdown Current vs Temperature

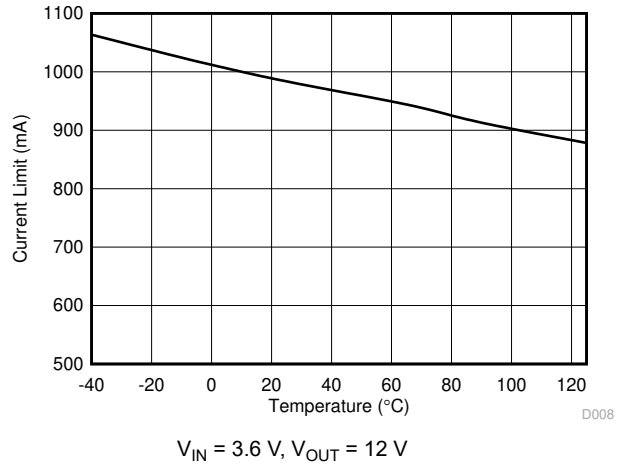

Figure 6-8. Current Limit vs Temperature

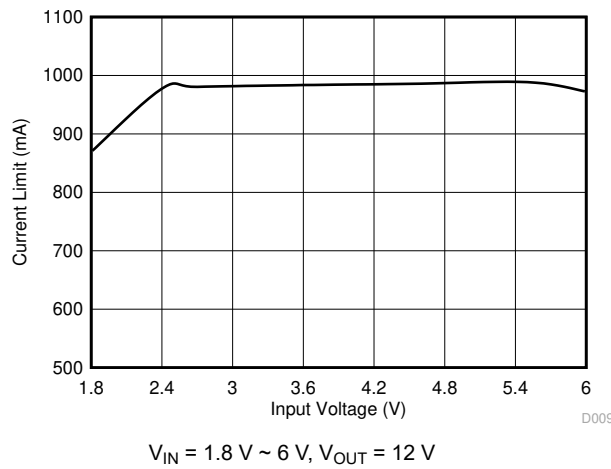

Figure 6-9. Current Limit vs Input Voltage

7 Detailed Description

7.1 Overview

The TLV61046A is a highly-integrated boost converter designed for applications requiring high voltage and small solution size such as PMOLED panel power supply and sensor module. The TLV61046A integrates a 30-V power switch, an input to output isolation switch, and a rectifier diode. It can output up to 28 V from input of a Li+ battery or two-cell alkaline batteries in series.

One common issue with conventional boost regulators is the conduction path from input to output even when the power switch is turned off. It creates three problems, which are inrush current during start-up, output leakage current during shutdown, and excessive over load current. In the TLV61046A, the isolation switch is turned off under shutdown mode and over load conditions, thereby opening the current path. Thus, the TLV61046A can truly disconnect the load from the input voltage and minimize the leakage current during shutdown mode.

The TLV61046A operates with a switching frequency at 1.0 MHz. This allows the use of small external components. The TLV61046A has an internal default 12-V output voltage setting by connecting the FB pin to the VIN pin. Thus, it only needs three external components to get 12-V output voltage. The TLV61046A has typical 980-mA switch current limit. It has 7-ms built-in soft start time to minimize the inrush current. The TLV61046A also implements output short circuit protection, output overvoltage protection, and thermal shutdown.

7.2 Functional Block Diagram

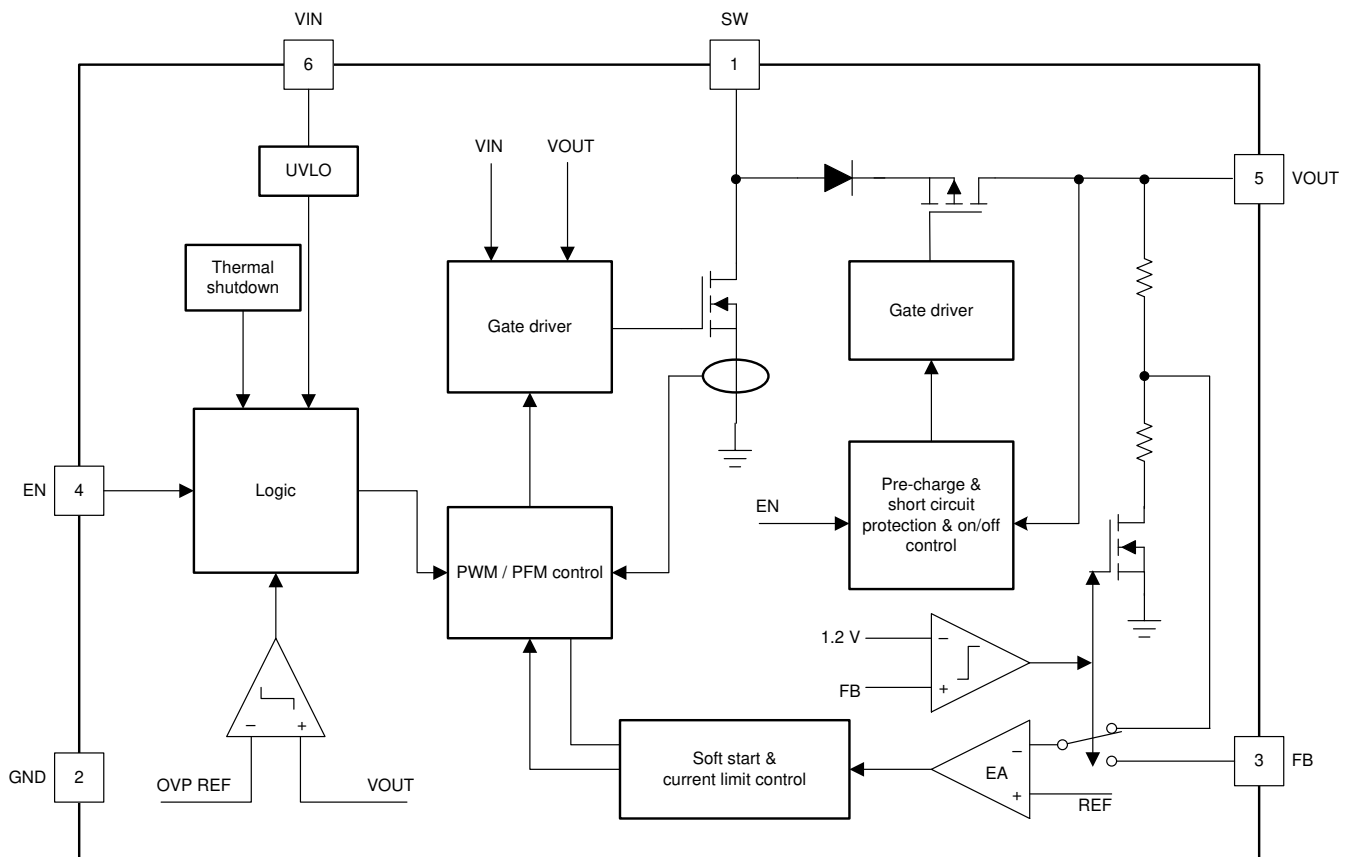

7.3 Feature Description

7.3.1 Undervoltage Lockout

An undervoltage lockout (UVLO) circuit stops the operation of the converter when the input voltage drops below the typical UVLO threshold of 1.55 V. A hysteresis of 200 mV is added so that the device cannot be enabled again until the input voltage goes up to 1.75 V. This function is implemented in order to prevent malfunctioning of the device when the input voltage is between 1.55 V and 1.75 V.

7.3.2 Enable and Disable

When the input voltage is above the maximal UVLO rising threshold of 1.8 V and the EN pin is pulled high, the TLV61046A is enabled. When the EN pin is pulled low, the TLV61046A goes into shutdown mode. The device stops switching and the isolation switch is turned off, providing the isolation between input and output. In shutdown mode, less than 1- μ A input current is consumed.

7.3.3 Soft Start

The TLV61046A begins soft start when the EN pin is pulled high. At the beginning of the soft start period, the isolation FET is turned on slowly to charge the output capacitor with 30-mA current for about 2 ms. This is called the pre-charge phase. After the pre-charge phase, the TLV61046A starts switching. This is called switching soft-start phase. An internal soft start circuit limits the peak inductor current according to the output voltage. When the output voltage is below 3 V, the peak inductor current is limited to 140 mA. Along with the output voltage going up from 3 V to 5 V, the peak current limit is gradually increased to the normal value of 980 mA. The switching soft start phase is about 5 ms typically. The soft start function reduces the inrush current during start-up.

7.3.4 Overvoltage Protection

The TLV61046A has internal output overvoltage protection (OVP) function. When the output voltage exceeds the OVP threshold of 29.2 V, the device stops switching. Once the output voltage falls 0.9 V below the OVP threshold, the device resumes operation again.

7.3.5 Output Short Circuit Protection

The TLV61046A starts to limit the output current whenever the output voltage drops below 4 V. The lower output voltage, the smaller output current limit. When the VOUT pin is shorted to ground, the output current is limited to less than 200 mA. This function protects the device from being damaged when the output is shorted to ground.

7.3.6 Thermal Shutdown

The TLV61046A goes into thermal shutdown once the junction temperature exceeds the thermal shutdown temperature threshold of 150°C typically. When the junction temperature drops below 130°C typically, the device starts operating again.

7.4 Device Functional Modes

The TLV61046A has two operation modes, PWM mode and power save mode.

7.4.1 PWM Mode

The TLV61046A uses a quasi-constant 1.0-MHz frequency pulse width modulation (PWM) at moderate to heavy load current. Based on the input voltage-to-output voltage ratio, a circuit predicts the required off-time. At the beginning of the switching cycle, the NMOS switching FET, shown in the functional block diagram, is turned on. The input voltage is applied across the inductor and the inductor current ramps up. In this phase, the output capacitor is discharged by the load current. When the inductor current hits the current threshold that is set by the output of the error amplifier, the PWM switch is turned off, and the power diode is forward-biased. The inductor transfers its stored energy to replenish the output capacitor and supply the load. When the off-time is expired, the next switching cycle starts again. The error amplifier compares the FB pin voltage with an internal reference voltage, and its output determines the inductor peak current.

The TLV61046A has a built-in compensation circuit that can accommodate a wide range of input voltage, output voltage, inductor value, and output capacitor value for stable operation.

7.4.2 Power Save Mode

The TLV61046A implements a power save mode with pulse frequency modulation (PFM) to improve efficiency at light load. When the load current decreases, the inductor peak current set by the output of the error amplifier declines to regulate the output voltage. When the inductor peak current hits the low limit of 200 mA, the output voltage will exceed the setting voltage as the load current decreases further. When the FB voltage hits the PFM reference voltage, the TLV61046A goes into power save mode. In power save mode, when the FB voltage rises and hits the PFM reference voltage, the device continues switching for several cycles because of the delay time

of the internal comparator, then it stops switching. The load is supplied by the output capacitor and the output voltage declines. When the FB voltage falls below the PFM reference voltage, after the delay time of the comparator, the device starts switching again to ramp up the output voltage.

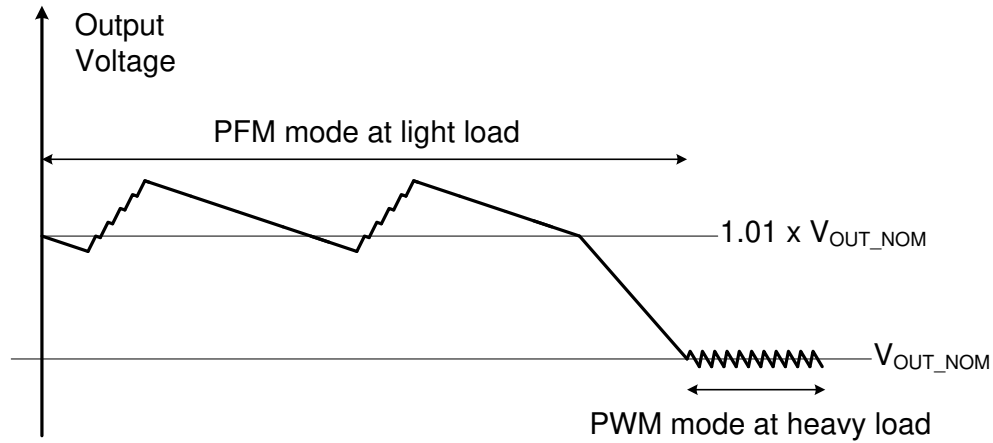

Figure 7-1. Output Voltage in PWM Mode and PFM Mode

8 Application and Implementation

Note

Information in the following applications sections is not part of the TI component specification, and TI does not warrant its accuracy or completeness. TI's customers are responsible for determining suitability of components for their purposes, as well as validating and testing their design implementation to confirm system functionality.

8.1 Application Information

The TLV61046A is a boost DC-DC converter integrating a power switch, an input to output isolation switch, and a rectifier diode. The device supports up to 28-V output with the input voltage ranging from 1.8 V to 5.5 V. The TLV61046A adopts the current-mode control with adaptive constant off-time. The switching frequency is quasi-constant at 1.0 MHz. The isolation switch disconnects the output from the input during shutdown to minimize leakage current.

The following design procedure can be used to select component values for the TLV61046A.

8.2 Typical Application - 12-V Output Boost Converter

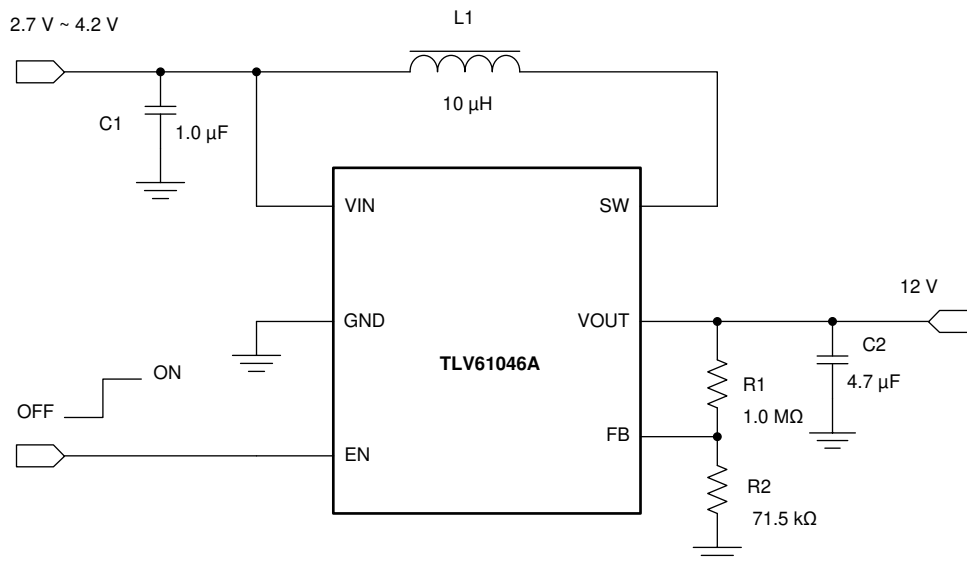

Figure 8-1. 12-V Boost Converter

8.2.1 Design Requirements

Table 8-1. Design Requirements

PARAMETERS	VALUES
Input Voltage	2.7 V ~ 4.2 V
Output Voltage	12 V
Output Current	50 mA
Output Voltage Ripple	±50 mV

8.2.2 Detailed Design Procedure

8.2.2.1 Custom Design With WEBENCH® Tools

[Click here](#) to create a custom design using the TLV61046A device with the WEBENCH® Power Designer.

1. Start by entering the input voltage (V_{IN}), output voltage (V_{OUT}), and output current (I_{OUT}) requirements.

2. Optimize the design for key parameters such as efficiency, footprint, and cost using the optimizer dial.
3. Compare the generated design with other possible solutions from Texas Instruments.

The WEBENCH Power Designer provides a customized schematic along with a list of materials with real-time pricing and component availability.

In most cases, these actions are available:

- Run electrical simulations to see important waveforms and circuit performance
- Run thermal simulations to understand board thermal performance
- Export customized schematic and layout into popular CAD formats
- Print PDF reports for the design, and share the design with colleagues

Get more information about WEBENCH tools at www.ti.com/WEBENCH.

8.2.2.2 Programming the Output Voltage

There are two ways to set the output voltage of the TLV61046A. When the FB pin is connected to the input voltage, the output voltage is fixed to 12 V. This function makes the TLV61046A only need three external components to minimize the solution size. The second way is to use an external resistor divider to set the desired output voltage.

By selecting the external resistor divider R1 and R2, as shown in [Equation 1](#), the output voltage is programmed to the desired value. When the output voltage is regulated, the typical voltage at the FB pin is V_{REF} of 795 mV.

$$R1 = \left(\frac{V_{OUT}}{V_{REF}} - 1 \right) \times R2 \quad (1)$$

where

- V_{OUT} is the desired output voltage
- V_{REF} is the internal reference voltage at the FB pin

For best accuracy, R2 should be kept smaller than 80 k Ω to ensure the current flowing through R2 is at least 100 times larger than the FB pin leakage current. Changing R2 towards a lower value increases the immunity against noise injection. Changing the R2 towards a higher value reduces the quiescent current for achieving higher efficiency at low load currents.

8.2.2.3 Inductor Selection

Because the selection of the inductor affects steady state operation, transient behavior, and loop stability, the inductor is the most important component in power regulator design. There are three important inductor specifications, inductor value, saturation current, and dc resistance (DCR).

The TLV61046A is designed to work with inductor values between 2.2 μ H and 22 μ H. Follow [Equation 2](#) to [Equation 4](#) to calculate the peak current of the inductor for the application. To calculate the peak current in the worst case, use the minimum input voltage, maximum output voltage, and maximum load current of the application. To have enough design margin, choose the inductor value with -30% tolerance, and a low power-conversion efficiency for the calculation.

In a boost regulator, the inductor dc current can be calculated with [Equation 2](#).

$$I_{L(DC)} = \frac{V_{OUT} \times I_{OUT}}{V_{IN} \times \eta} \quad (2)$$

where

- V_{OUT} is output voltage
- I_{OUT} is output current
- V_{IN} is input voltage

- η is power conversion efficiency, use 80% for most applications

The inductor ripple current is calculated with [Equation 3](#) for an asynchronous boost converter in continuous conduction mode (CCM).

$$\Delta I_{L(P-P)} = \frac{V_{IN} \times (V_{OUT} + 0.8V - V_{IN})}{L \times f_{SW} \times (V_{OUT} + 0.8V)} \quad (3)$$

where

- $\Delta I_{L(P-P)}$ is inductor ripple current
- L is inductor value
- f_{SW} is switching frequency
- V_{OUT} is output voltage
- V_{IN} is input voltage

Therefore, the inductor peak current is calculated with [Equation 4](#).

$$I_{L(P)} = I_{L(DC)} + \frac{\Delta I_{L(P-P)}}{2} \quad (4)$$

Normally, it is advisable to work with an inductor peak-to-peak current of less than 40% of the average inductor current for maximum output current. A smaller ripple from a larger valued inductor reduces the magnetic hysteresis losses in the inductor and EMI. But in the same way, load transient response time is increased. Because the TLV61046A is for relatively small output current application, the inductor peak-to-peak current can be as high as 200% of the average current with a small inductor value, which means the TLV61046A always works in DCM mode. [Table 8-2](#) lists the recommended inductors for the TLV61046A.

Table 8-2. Recommended Inductors for the TLV61046A

PART NUMBER	L(μH)	DCR MAX (mΩ)	SATURATION CURRENT (A)	SIZE (LxWxH)	VENDOR ⁽¹⁾
FDSD0420-H-100M	10	200	2.5	4.2x4.2x2.0	Toko
CDRH3D23/HP	10	198	1.02	4.0x4.0x2.5	Sumida
74438336100	10	322	2.35	3.2x3.2x2.0	Würth
VLS4012-4R7M	4.7	132	1.1	4.0x4.0x1.2	TDK

(1) See [Third-party Products Disclaimer](#)

8.2.2.4 Input and Output Capacitor Selection

The output capacitor is mainly selected to meet the requirements for output ripple and loop stability. This ripple voltage is related to the capacitance of the capacitor and its equivalent series resistance (ESR). Assuming a ceramic capacitor with zero ESR, the minimum capacitance needed for a given ripple can be calculated by:

$$C_{OUT} = \frac{I_{OUT} \times D_{MAX}}{f_{SW} \times V_{RIPPLE}} \quad (5)$$

where

- D_{MAX} is maximum switching duty cycle
- V_{RIPPLE} is peak to peak output voltage ripple

The ESR impact on the output ripple must be considered if tantalum or aluminum electrolytic capacitors are used.

Care must be taken when evaluating a ceramic capacitor's derating under dc bias, aging, and ac signal. For example, the dc bias can significantly reduce capacitance. A ceramic capacitor can lose more than 50% of its

capacitance at its rated voltage. Therefore, always leave margin on the voltage rating to ensure adequate capacitance at the required output voltage.

It is recommended to use the output capacitor with effective capacitance in the range of 0.47 μF to 10 μF . The output capacitor affects loop stability of the boost regulator. If the output capacitor is below the range, the boost regulator can potentially become unstable. Increasing the output capacitor makes the output voltage ripple smaller in PWM mode.

For input capacitor, a ceramic capacitor with more than 1.0 μF is enough for most applications.

8.2.3 Application Performance Curves

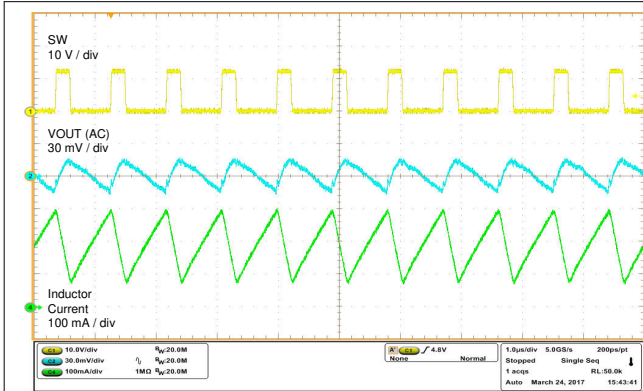

$V_{IN} = 3.6\text{ V}, V_{OUT} = 12\text{ V}, I_{OUT} = 50\text{ mA}$

Figure 8-2. Switching Waveforms in PWM CCM Mode

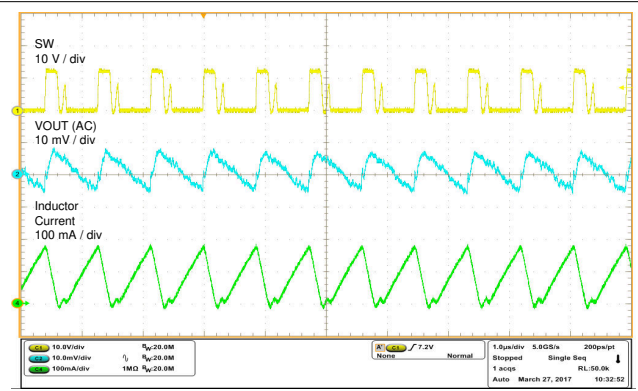

$V_{IN} = 3.6\text{ V}, V_{OUT} = 12\text{ V}, I_{OUT} = 18\text{ mA}$

Figure 8-3. Switching Waveforms in PWM DCM Mode

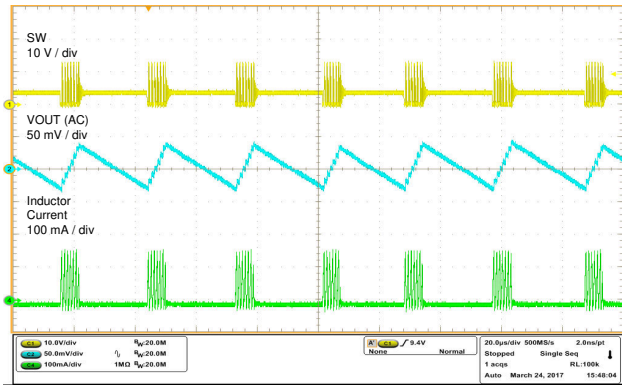

$V_{IN} = 3.6\text{ V}, V_{OUT} = 12\text{ V}, I_{OUT} = 3\text{ mA}$

Figure 8-4. Switching Waveforms in Power Save Mode

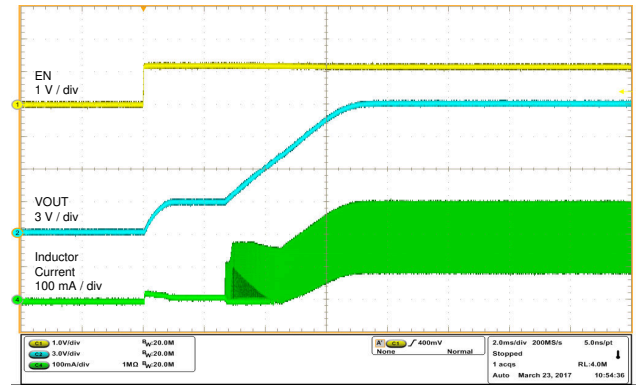

$V_{IN} = 3.6\text{ V}, V_{OUT} = 12\text{ V}, I_{OUT} = 50\text{ mA}$

Figure 8-5. Soft Start-up Waveforms

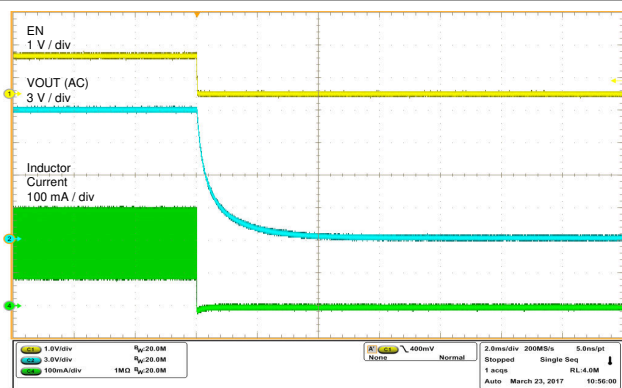

$V_{IN} = 3.6\text{ V}, V_{OUT} = 12\text{ V}, I_{OUT} = 50\text{ mA}$

Figure 8-6. Shutdown Waveforms

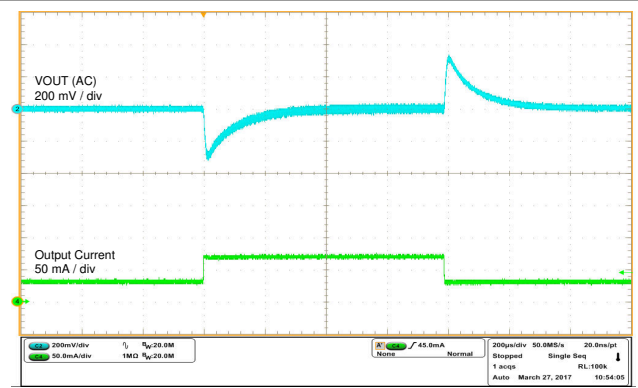

$V_{IN} = 3.6\text{ V}, V_{OUT} = 12\text{ V}$

Figure 8-7. 30-mA to 70-mA Load Transient Response

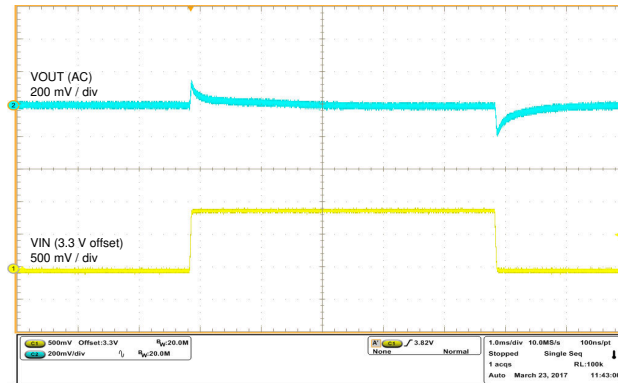

$V_{OUT} = 12\text{ V}$, $I_{OUT} = 50\text{ mA}$

Figure 8-8. Input Voltage from 3.3-V to 4.2-V Line Transient Response

8.3 System Examples

8.3.1 Fixed 12-V Output Voltage with Three External Components

The TLV61046A can output fixed 12-V voltage by connecting the FB pin to the VIN pin to save the external resistor divider. The [Figure 8-9](#) shows the application circuit.

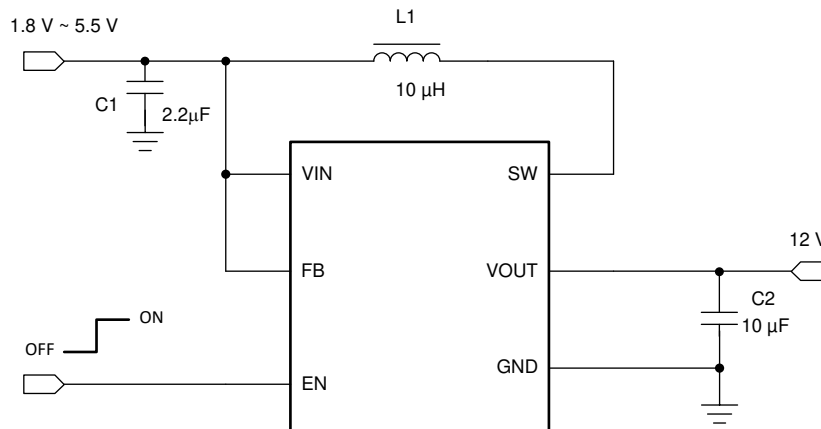

Figure 8-9. Fixed 12-V Output Voltage by Connecting the FB Pin to VIN Pin

9 Power Supply Recommendations

The device is designed to operate from an input voltage supply range between 1.8 V to 5.5 V. This input supply must be well regulated. If the input supply is located more than a few inches from the converter, additional bulk capacitance can be required in addition to the ceramic bypass capacitors. A typical choice is an electrolytic or tantalum capacitor with a value of 47 μF . The output current of the input power supply needs to be rated according to the supply voltage, output voltage, and output current of the TLV61046A.

10 Layout

10.1 Layout Guidelines

As for all switching power supplies, especially those running at high switching frequency and high currents, layout is an important design step. If the layout is not carefully done, the regulator could suffer from instability and noise problems. To maximize efficiency, switch rise and fall time are very fast. To prevent radiation of high frequency noise (for example, EMI), proper layout of the high-frequency switching path is essential. Minimize the length and area of all traces connected to the SW pin, and always use a ground plane under the switching regulator to minimize interplane coupling. The input capacitor needs not only to be close to the VIN pin, but also to the GND pin in order to reduce input supply ripple.

The most critical current path for all boost converters is from the switching FET, through the rectifier diode, then the output capacitors, and back to ground of the switching FET. This high current path contains nanosecond rise and fall time and should be kept as short as possible. Therefore, the output capacitors need not only to be close to the VOUT pin, but also to the GND pin to reduce the overshoot at the SW pin and VOUT pin.

10.2 Layout Example

A large ground plane on the bottom layer connects the ground pins of the components on the top layer through vias.

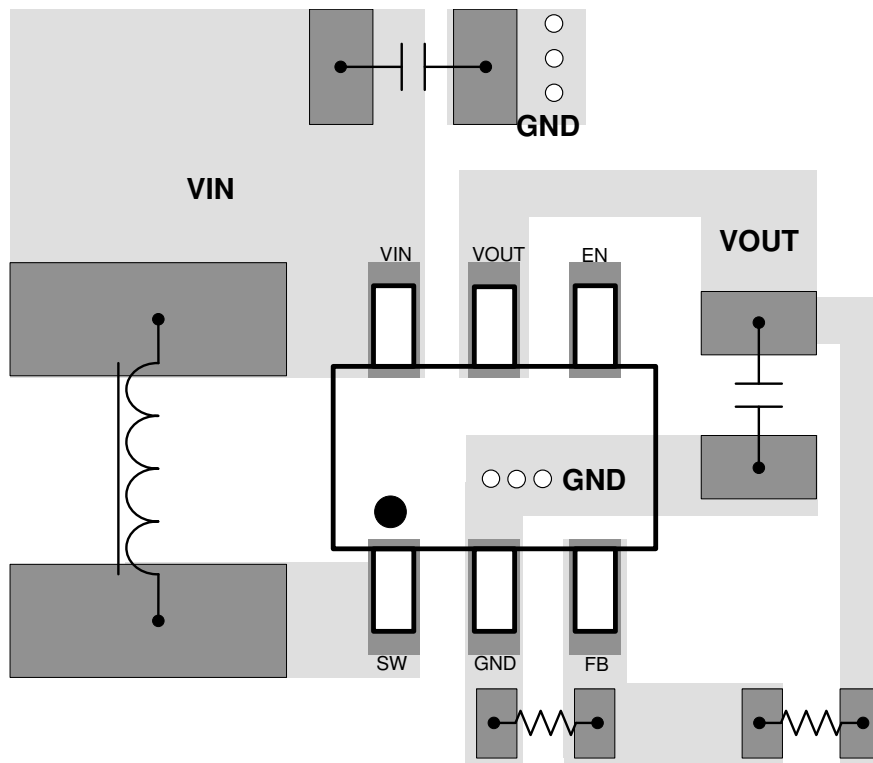

Figure 10-1. PCB Layout Example

11 Device and Documentation Support

11.1 Device Support

11.1.1 Third-Party Products Disclaimer

TI'S PUBLICATION OF INFORMATION REGARDING THIRD-PARTY PRODUCTS OR SERVICES DOES NOT CONSTITUTE AN ENDORSEMENT REGARDING THE SUITABILITY OF SUCH PRODUCTS OR SERVICES OR A WARRANTY, REPRESENTATION OR ENDORSEMENT OF SUCH PRODUCTS OR SERVICES, EITHER ALONE OR IN COMBINATION WITH ANY TI PRODUCT OR SERVICE.

11.1.2 Development Support

11.1.2.1 Custom Design With WEBENCH® Tools

[Click here](#) to create a custom design using the TLV61046A device with the WEBENCH® Power Designer.

1. Start by entering the input voltage (V_{IN}), output voltage (V_{OUT}), and output current (I_{OUT}) requirements.
2. Optimize the design for key parameters such as efficiency, footprint, and cost using the optimizer dial.
3. Compare the generated design with other possible solutions from Texas Instruments.

The WEBENCH Power Designer provides a customized schematic along with a list of materials with real-time pricing and component availability.

In most cases, these actions are available:

- Run electrical simulations to see important waveforms and circuit performance
- Run thermal simulations to understand board thermal performance
- Export customized schematic and layout into popular CAD formats
- Print PDF reports for the design, and share the design with colleagues

Get more information about WEBENCH tools at www.ti.com/WEBENCH.

11.2 Receiving Notification of Documentation Updates

To receive notification of documentation updates, navigate to the device product folder on ti.com. Click on *Subscribe to updates* to register and receive a weekly digest of any product information that has changed. For change details, review the revision history included in any revised document.

11.3 Support Resources

[TI E2E™ support forums](#) are an engineer's go-to source for fast, verified answers and design help — straight from the experts. Search existing answers or ask your own question to get the quick design help you need.

Linked content is provided "AS IS" by the respective contributors. They do not constitute TI specifications and do not necessarily reflect TI's views; see TI's [Terms of Use](#).

11.4 Trademarks

TI E2E™ is a trademark of Texas Instruments.

WEBENCH® are registered trademarks of Texas Instruments.

All trademarks are the property of their respective owners.

11.5 Electrostatic Discharge Caution



This integrated circuit can be damaged by ESD. Texas Instruments recommends that all integrated circuits be handled with appropriate precautions. Failure to observe proper handling and installation procedures can cause damage.

ESD damage can range from subtle performance degradation to complete device failure. Precision integrated circuits may be more susceptible to damage because very small parametric changes could cause the device not to meet its published specifications.

11.6 Glossary

[TI Glossary](#) This glossary lists and explains terms, acronyms, and definitions.

12 Mechanical, Packaging, and Orderable Information

The following pages include mechanical, packaging, and orderable information. This information is the most current data available for the designated devices. This data is subject to change without notice and revision of this document. For browser-based versions of this data sheet, refer to the left-hand navigation.

PACKAGING INFORMATION

Orderable Device	Status (1)	Package Type	Package Drawing	Pins	Package Qty	Eco Plan (2)	Lead finish/ Ball material (6)	MSL Peak Temp (3)	Op Temp (°C)	Device Marking (4/5)	Samples
TLV61046ADBVR	ACTIVE	SOT-23	DBV	6	3000	RoHS & Green	NIPDAU	Level-1-260C-UNLIM	-40 to 125	1C4F	Samples
TLV61046ADBVT	ACTIVE	SOT-23	DBV	6	250	RoHS & Green	NIPDAU	Level-1-260C-UNLIM	-40 to 125	1C4F	Samples

(1) The marketing status values are defined as follows:

ACTIVE: Product device recommended for new designs.

LIFEBUY: TI has announced that the device will be discontinued, and a lifetime-buy period is in effect.

NRND: Not recommended for new designs. Device is in production to support existing customers, but TI does not recommend using this part in a new design.

PREVIEW: Device has been announced but is not in production. Samples may or may not be available.

OBSOLETE: TI has discontinued the production of the device.

(2) **RoHS:** TI defines "RoHS" to mean semiconductor products that are compliant with the current EU RoHS requirements for all 10 RoHS substances, including the requirement that RoHS substance do not exceed 0.1% by weight in homogeneous materials. Where designed to be soldered at high temperatures, "RoHS" products are suitable for use in specified lead-free processes. TI may reference these types of products as "Pb-Free".

RoHS Exempt: TI defines "RoHS Exempt" to mean products that contain lead but are compliant with EU RoHS pursuant to a specific EU RoHS exemption.

Green: TI defines "Green" to mean the content of Chlorine (Cl) and Bromine (Br) based flame retardants meet JS709B low halogen requirements of <=1000ppm threshold. Antimony trioxide based flame retardants must also meet the <=1000ppm threshold requirement.

(3) MSL, Peak Temp. - The Moisture Sensitivity Level rating according to the JEDEC industry standard classifications, and peak solder temperature.

(4) There may be additional marking, which relates to the logo, the lot trace code information, or the environmental category on the device.

(5) Multiple Device Markings will be inside parentheses. Only one Device Marking contained in parentheses and separated by a "~" will appear on a device. If a line is indented then it is a continuation of the previous line and the two combined represent the entire Device Marking for that device.

(6) Lead finish/Ball material - Orderable Devices may have multiple material finish options. Finish options are separated by a vertical ruled line. Lead finish/Ball material values may wrap to two lines if the finish value exceeds the maximum column width.

Important Information and Disclaimer:The information provided on this page represents TI's knowledge and belief as of the date that it is provided. TI bases its knowledge and belief on information provided by third parties, and makes no representation or warranty as to the accuracy of such information. Efforts are underway to better integrate information from third parties. TI has taken and continues to take reasonable steps to provide representative and accurate information but may not have conducted destructive testing or chemical analysis on incoming materials and chemicals. TI and TI suppliers consider certain information to be proprietary, and thus CAS numbers and other limited information may not be available for release.

In no event shall TI's liability arising out of such information exceed the total purchase price of the TI part(s) at issue in this document sold by TI to Customer on an annual basis.

TAPE AND REEL INFORMATION

QUADRANT ASSIGNMENTS FOR PIN 1 ORIENTATION IN TAPE

*All dimensions are nominal

Device	Package Type	Package Drawing	Pins	SPQ	Reel Diameter (mm)	Reel Width W1 (mm)	A0 (mm)	B0 (mm)	K0 (mm)	P1 (mm)	W (mm)	Pin1 Quadrant
TLV61046ADBVR	SOT-23	DBV	6	3000	180.0	8.4	3.2	3.2	1.4	4.0	8.0	Q3
TLV61046ADBVT	SOT-23	DBV	6	250	180.0	8.4	3.2	3.2	1.4	4.0	8.0	Q3

TAPE AND REEL BOX DIMENSIONS

*All dimensions are nominal

Device	Package Type	Package Drawing	Pins	SPQ	Length (mm)	Width (mm)	Height (mm)
TLV61046ADBVR	SOT-23	DBV	6	3000	210.0	185.0	35.0
TLV61046ADBVT	SOT-23	DBV	6	250	210.0	185.0	35.0

EXAMPLE BOARD LAYOUT

DBV0006A

SOT-23 - 1.45 mm max height

SMALL OUTLINE TRANSISTOR

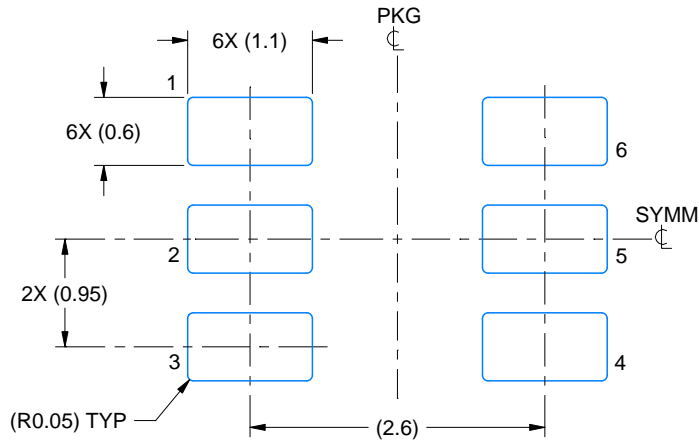

LAND PATTERN EXAMPLE
EXPOSED METAL SHOWN
SCALE:15X

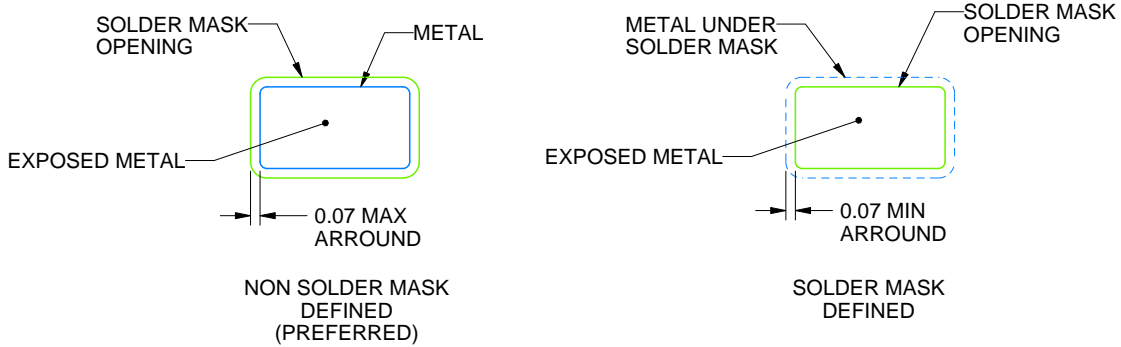

SOLDER MASK DETAILS

4214840/F 05/2024

NOTES: (continued)

- Publication IPC-7351 may have alternate designs.
- Solder mask tolerances between and around signal pads can vary based on board fabrication site.

EXAMPLE STENCIL DESIGN

DBV0006A

SOT-23 - 1.45 mm max height

SMALL OUTLINE TRANSISTOR

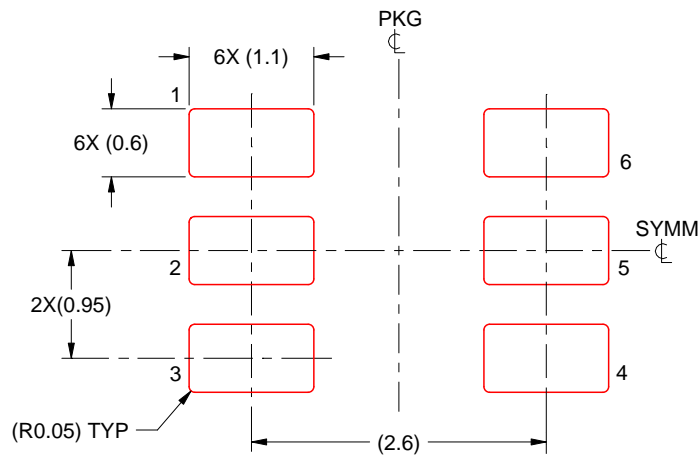

SOLDER PASTE EXAMPLE
BASED ON 0.125 mm THICK STENCIL
SCALE:15X

4214840/F 05/2024

NOTES: (continued)

8. Laser cutting apertures with trapezoidal walls and rounded corners may offer better paste release. IPC-7525 may have alternate design recommendations.
9. Board assembly site may have different recommendations for stencil design.

IMPORTANT NOTICE AND DISCLAIMER

TI PROVIDES TECHNICAL AND RELIABILITY DATA (INCLUDING DATA SHEETS), DESIGN RESOURCES (INCLUDING REFERENCE DESIGNS), APPLICATION OR OTHER DESIGN ADVICE, WEB TOOLS, SAFETY INFORMATION, AND OTHER RESOURCES "AS IS" AND WITH ALL FAULTS, AND DISCLAIMS ALL WARRANTIES, EXPRESS AND IMPLIED, INCLUDING WITHOUT LIMITATION ANY IMPLIED WARRANTIES OF MERCHANTABILITY, FITNESS FOR A PARTICULAR PURPOSE OR NON-INFRINGEMENT OF THIRD PARTY INTELLECTUAL PROPERTY RIGHTS.

These resources are intended for skilled developers designing with TI products. You are solely responsible for (1) selecting the appropriate TI products for your application, (2) designing, validating and testing your application, and (3) ensuring your application meets applicable standards, and any other safety, security, regulatory or other requirements.

These resources are subject to change without notice. TI grants you permission to use these resources only for development of an application that uses the TI products described in the resource. Other reproduction and display of these resources is prohibited. No license is granted to any other TI intellectual property right or to any third party intellectual property right. TI disclaims responsibility for, and you will fully indemnify TI and its representatives against, any claims, damages, costs, losses, and liabilities arising out of your use of these resources.

TI's products are provided subject to [TI's Terms of Sale](#) or other applicable terms available either on [ti.com](https://www.ti.com) or provided in conjunction with such TI products. TI's provision of these resources does not expand or otherwise alter TI's applicable warranties or warranty disclaimers for TI products.

TI objects to and rejects any additional or different terms you may have proposed.

Mailing Address: Texas Instruments, Post Office Box 655303, Dallas, Texas 75265
Copyright © 2024, Texas Instruments Incorporated