

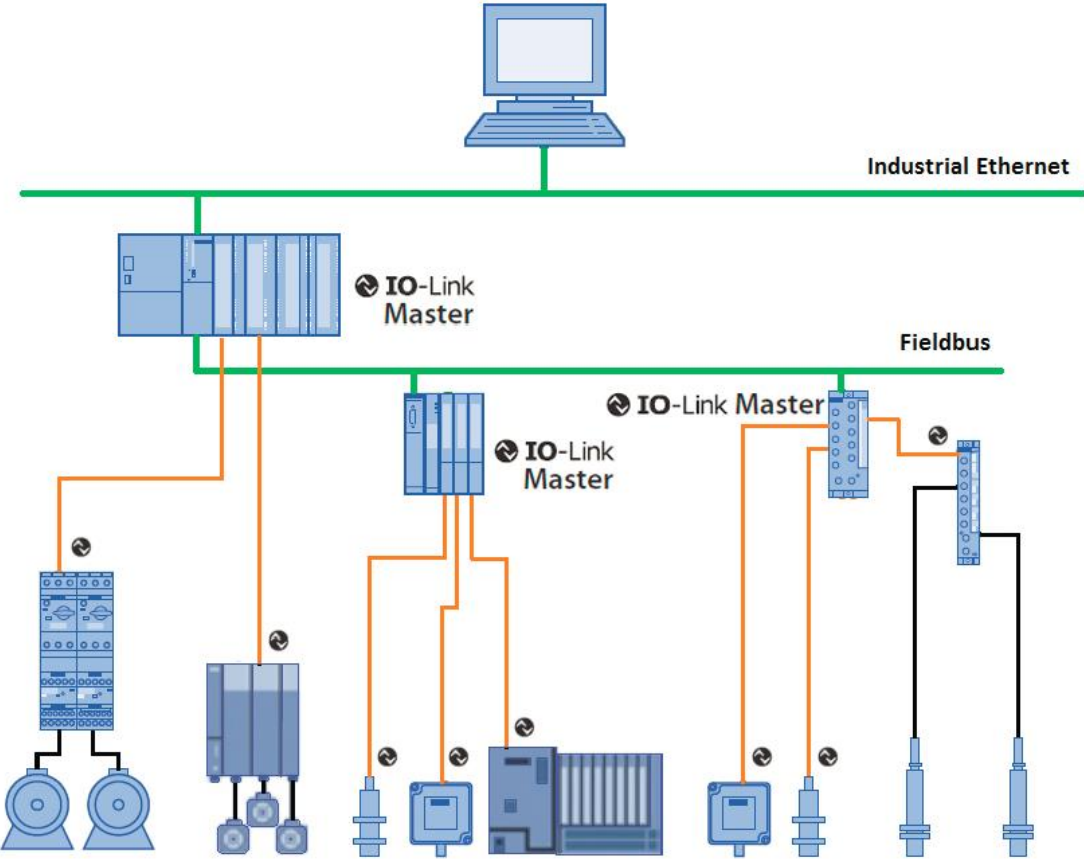

IO-Link Solutions

Product family overview

Field Network structure



IO-Link Communication Layer

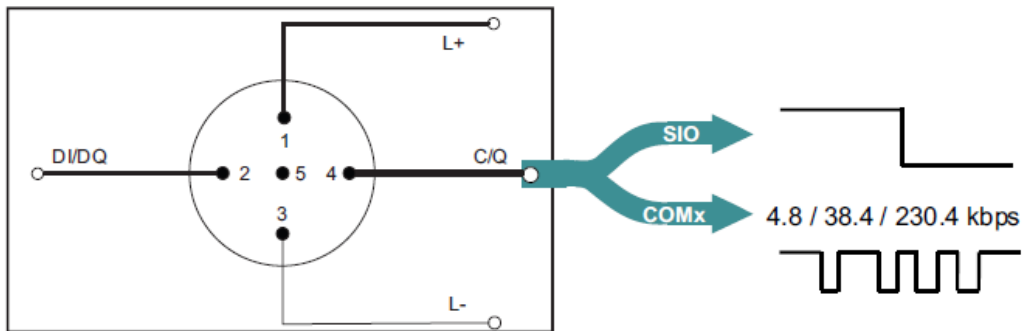

Pin	Signal	Definition	Standard
1	L+	24 V	IEC 61131-2
2	I/Q	Not connected, DI, or DO	IEC 61131-2
3	L-	0 V	IEC 61131-2
4	Q	"Switching signal" DI (SIO)	IEC 61131-2
	C	"Coded switching" (COM1, COM2, COM3)	IEC 61131-9

Used for this project

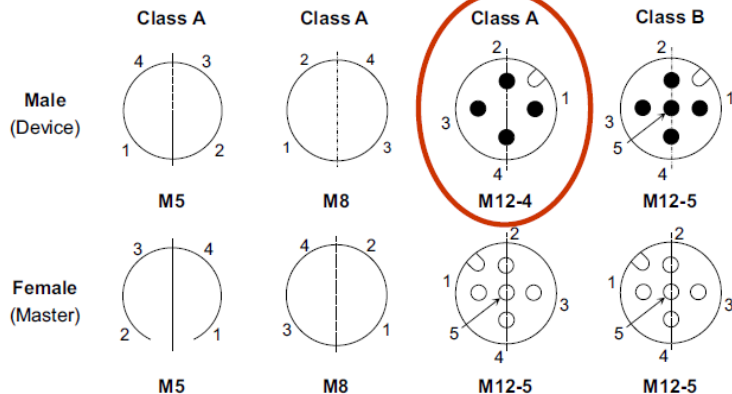

M12 connectors are A-coded according to IEC 61076-2-101

End Applications for IO-Link / SIO

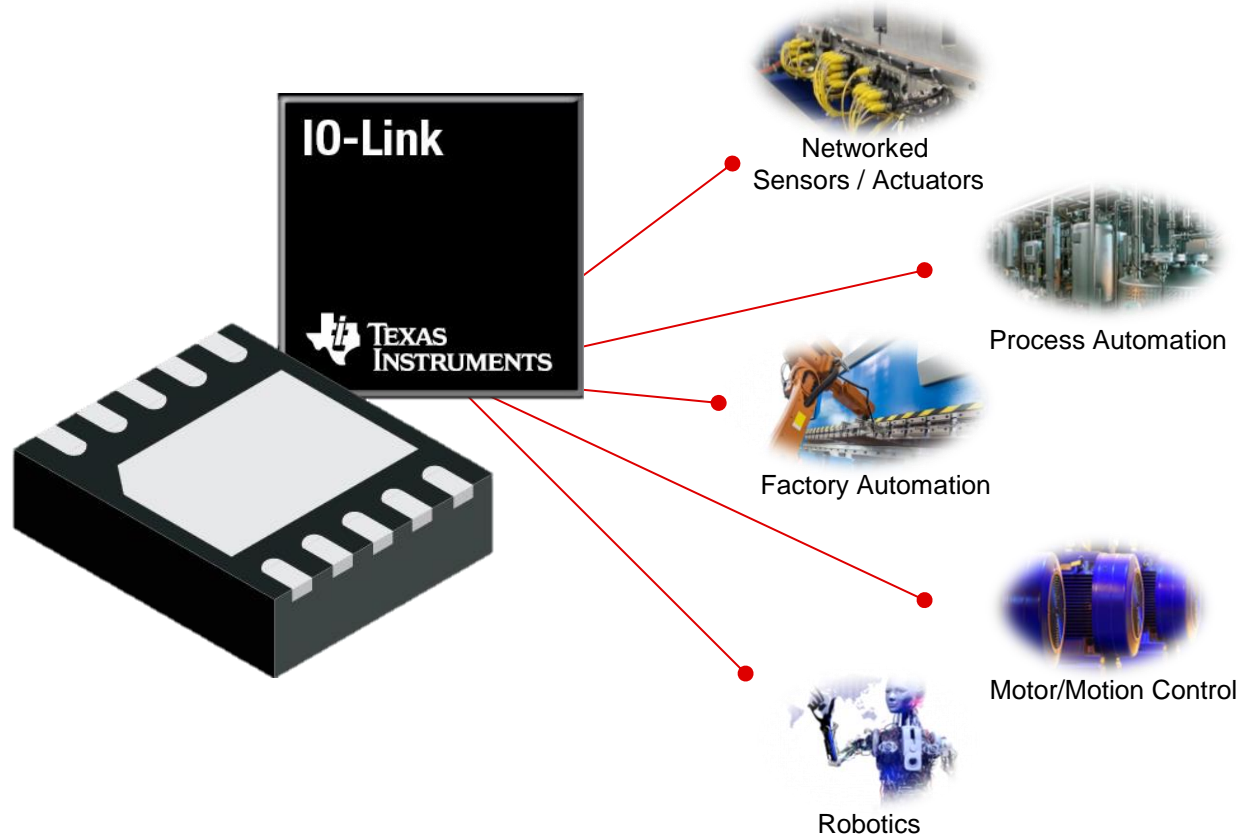

TIOL111 IO-Link Device Transceiver

Fault Tolerant with Integrated IEC ESD, EFT and Surge Protection

Features

- 7V to 36V supply voltage
- IO-Link, PNP or NPN or configurable output
- Low residual voltage of 1.75V at 250mA
- Tolerant to $\pm 65\text{V}$ transients $< 100\mu\text{s}$
- Reverse polarity protection of up to $\pm 55\text{V}$
- Integrated protection on L+ and CQ
 - $\pm 16\text{kV}$ IEC 61000-4-2 (ESD) Contact Discharge
 - $\pm 4\text{kV}$ IEC 61000-4-4 (EFT) Criterion A (5/50ns)
 - $\pm 1.2\text{kV}/500\Omega$ IEC 61000-4-5 (Surge) (1.2/50 μs)
- Configurable current limit up to 350mA
- $< 2\mu\text{A}$ CQ leakage current
- $< 2\text{mA}$ quiescent supply current
- 3.3V/5V LDO options for up to 20mA current
- Over temperature warning and thermal protection
- Remote wake-up and fault indicators
- Extended ambient industrial temperature: -40°C to $+125^{\circ}\text{C}$
- 2.5mm x 3.0mm VSON package

Applications

- IO-Link enabled device nodes

Benefits

- Small package to fit in most cylindrical sensors
- Integrated IEC surge protection for low cost and simple system design with minimal external components
- High voltage tolerant L+ and CQ pins for higher system level protection circuit design
- Low leakage for improved ADC accuracy
- Low power consumption
- Integrated LDO to power external system components

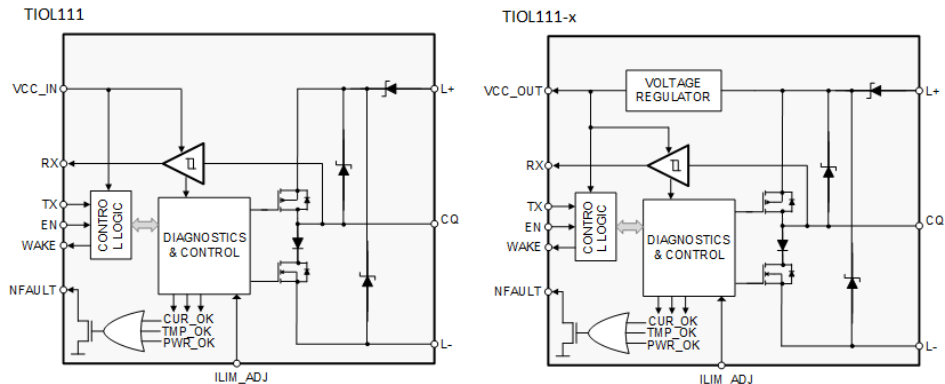

TIOS101 Digital Sensor Output Driver

Fault Tolerant with Integrated IEC ESD, EFT and Surge Protection

Features

- 7V to 36V supply voltage
- PNP, NPN or push-pull configurable output
- Low residual voltage of 1.75V at 250mA
- Tolerant to $\pm 65\text{V}$ transients $< 100\mu\text{s}$
- Reverse polarity protection of up to $\pm 55\text{V}$
- Integrated protection on VCC and OUT
 - $\pm 16\text{kV}$ IEC 61000-4-2 (ESD) Contact Discharge
 - $\pm 4\text{kV}$ IEC 61000-4-4 (EFT) Criterion A (5/50ns)
 - $\pm 1.2\text{kV}/500\Omega$ IEC 61000-4-5 (Surge) (1.2/50 μs)
- Configurable current limit up to 350mA
- $< 2.2\text{mA}$ quiescent supply current
- 3.3V/5V LDO options for up to 20mA current
- Over temperature warning and thermal protection
- Fault indicator
- Extended ambient industrial temperature: -40°C to $+125^{\circ}\text{C}$
- 2.5mm x 3.0mm VSON package

Applications

- Proximity Switches
- Capacitive and Inductive Sensors
- Digital Outputs

Benefits

- Small package to fit in most cylindrical sensors
- Integrated IEC surge protection for low cost and simple system design with minimal external components
- High voltage tolerant VCC and OUT pins for higher system level protection circuit design
- Low power consumption
- Integrated LDO to power external system level components

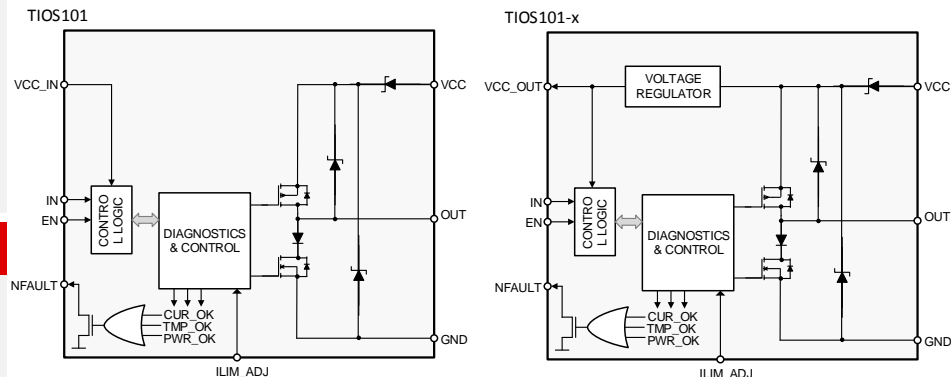

TIOL111 / TIOS101 Device Size / EMC Protection

- Industry's smallest, thermally-enhanced IO-Link package
- 2.5mm x 3.0mm dimensions for the most space constrained applications
- Flow through pinout enables easy layout with signal on X-axis
 - Perfect for small cylinder sensor applications
- Thermal pad aides in the conduction of heat

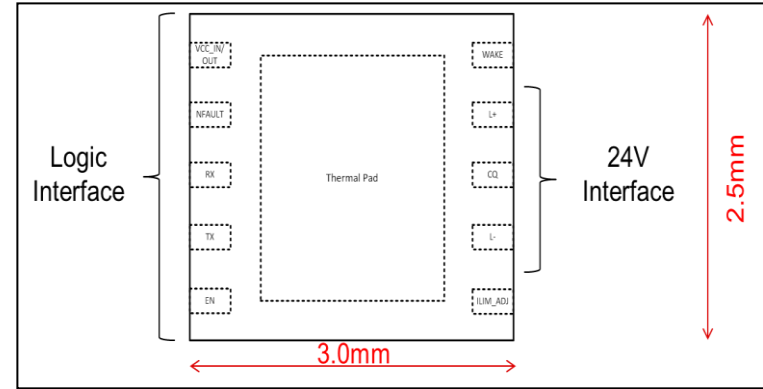

- Highest level of integrated protection available today!
- Integrated EMC protection
 - 16kV IEC 61000-4-2 (ESD) Contact Discharge
 - 4kV IEC 61000-4-4 (EFT) Criterion A (5/50ns)
 - 1.2kV/500Ω IEC 61000-4-5 (Surge) (1.2/50μs)
- Eliminates or reduces the need for external TVS diodes

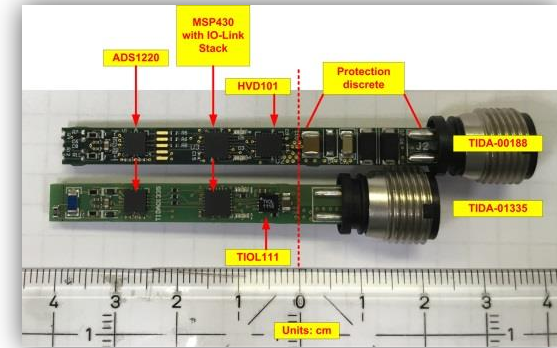

TIOL111 / TIOS101 Residual / Transient Voltage

- Power dissipation due to load current = (Residual Voltage) * IO
- Residual voltage is a critical factor of device power dissipation and system thermal management

- Tolerant to $\pm 65V$ transients $< 100\mu s$
- Industry's highest tolerance provide TVS diode flexibility

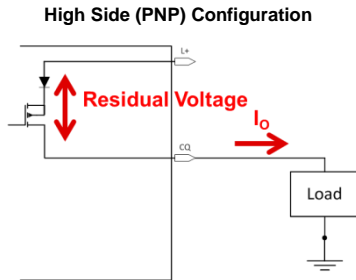

	Driver Current Output	Residual Voltage
High Side	100mA	1.1V
	200mA	1.5V
	250mA	1.75V
Low Side	100mA	1.1V
	200mA	1.5V
	250mA	1.75V

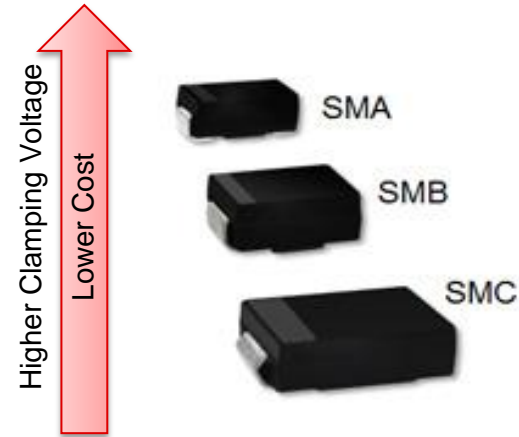

TIOL111 / TIOS101 Current limit / BOM Flexibility

- Supports design-configurable current output
- 40mA to 350mA current limit via external resistor on ILIM_ADJ
- 350mA default value w/ 0Ω resistor
- Current is guaranteed over temperature and voltage

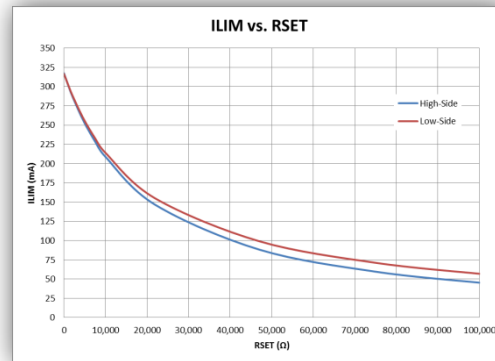

- Simple pin-programmable interface
- Full pin compatibility allow for flexible product build options for SIO and IO-Link variants
- Small, flow-through packaging makes layout straightforward

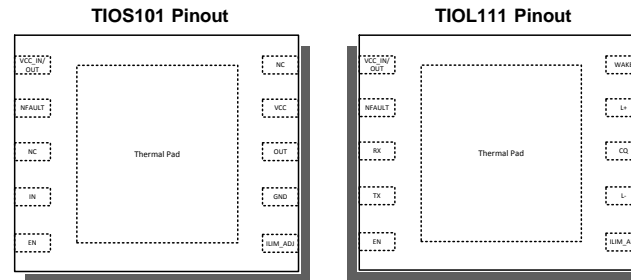

Pin and drop-in compatibility between SIO and IO-Link solutions

IO-Link / SIO Portfolio

Feature	TIOL111 TIOL111-3 TIOL111-5	TIOS101 TIOS101-3 TIOS101-5	SN65HVD101 SN65HVD102
IO-Link / SIO	IO-Link	SIO	IO-Link
Type	Slave		
Output	PNP, NPN, Communication (IO-Link)	PNP, NPN, push-pull	PNP, NPN, push-pull
Data Rate	COM1, COM2, COM3	250 kbps	COM1, COM2, COM3
Supply Voltage	7 to 36V		9 to 30V
ESD Human-body model (HBM)	±4 kV		±2 kV
IEC 61000-4-2 ESD (contact discharge)	±16 kV		-
IEC 61000-4-4 ESD Criterion-A (electrical fast transient)	±4 kV		-
IEC-61000-4-5 ESD Surge	±1.2 kV		-
Max CQ leakage	±2 µA	-	±2 µA
LDO output	3.3V (-3) or 5V (-5)		3.3V or 5V
Temperature	-40 to 125C		-40 to 105C
Package type / size	VSON / 2.5 x 3mm	VSON / 2.5 x 3mm	VQFN / 3.5 x 4mm



IO-Link – Our Differentiation

±65V Fault Protection and Integrated IEC ESD, EFT, Surge
Most robust and reduced system BOM



Lowest Residual Voltage at Maximum Output Current
Best power dissipation and thermals



Tiny Package
Reduced footprint in sensor PCBs

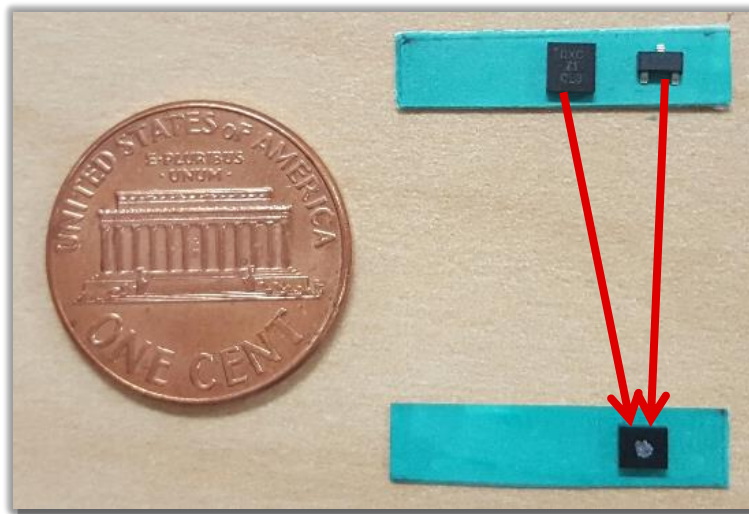
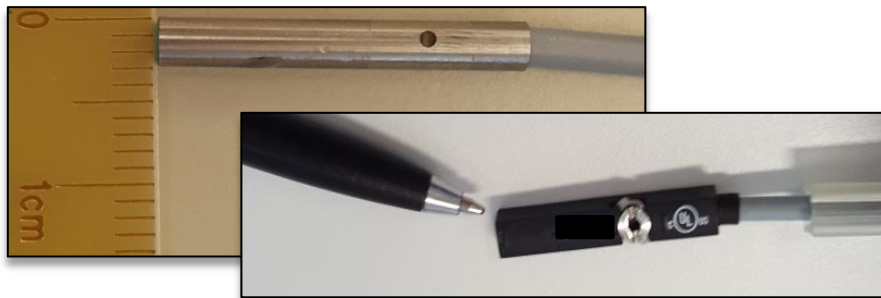

Competitor

TIOL111

IO-Link / SIO Development Tools & Resources

Development Tools

TIOL111-5 Evaluation Module



The TIOL111-5 EVM provides users with the ability to evaluate TI's TIOL111x family of IO-Link transceivers. The EVM includes the ability to measure and monitor numerous signals including L+, L-, CQ, Tx, Rx, and more while also being able to adjust the device output current via an on-board potentiometer.

TIOS101-5 Evaluation Module

The TIOS101-5 EVM provides users with the ability to evaluate TI's TIOS101x family of Digital Output (SIO) drivers. The EVM includes the TIOS101-5 which includes an on-chip 5-V LDO. With pin to pin compatibility throughout the TIOS101 family, the EVM can also support the TIOS101 (no LDO) or the TIOS101-3 (3.3-V LDO).



SN65HVD101 /SN65HVD102 Evaluation Module



Enables users to easily the SN65HVD101 IO-Link transceiver. Users can also utilize this board to evaluate the SN65HVD102 device by exchanging devices.

Design Resources

Hall Effect Sensor Reference Design



This design features the TIOS101 digital output driver and detect magnetic fields and toggles its output when the magnetic field strength exceeds a specific threshold. The design size is optimized to fit into small cylindrical sensors and measures only 3mm x 15mm.

IO-Link Transmitter Reference Design

The TIDA-01335 builds upon the TIDA-00188 design by utilizing the TIOL111's small 2.5 x 3mm package and integrated EMC protection to reduce the PCB by ~20%. This design allows designers to easily see how TIOL111 can fit into cylindrical sensors.

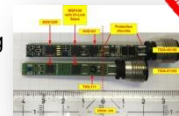

- [TIDA-01478 – IO-Link device with secondary digital output and DC-DC](#)
- [TIDA-00461 – Firmware update for IO-Link](#)
- [TIDA-01239 – Proximity switch with CapTIvate teach button](#)
- [TIDA-01250 – Smart solenoid driver for pneumatic valves](#)
- [TIDA-01386 – Ultrasound AFE for displacement](#)

Available today!

- [TIDA-00188 – IO-Link with 24-bit RTD front-end](#)
- [TIDA-00340 – Hall proximity switch IO-Link](#)
- [TIDA-00341 – Linear hall proximity sensor IO-Link](#)
- [TIDA-00339 – IO-Link with SPI sensor IF](#)
- [TIDA-00457 – 4-20mA to IO-Link bridge](#)

E2E Forums

TI's Engineer to Engineer Community: <http://e2e.ti.com>

Transceivers Interface **Industrial CAN Products**

www.ti.com/can

TI: History of CAN Innovations

SN65HVD23x

First 3.3V supply
CAN transceivers

SN65HVD251

Popular Industrial CAN
Transceiver

SN65HVD1050

Low EMI CAN
transceiver

ISO1050

First galvanic isolated
CAN for industrial

SN65HVD25x/26x

Turbo CAN for loaded
networks

TCAN1042/1051

High Bus Fault
Protected CAN
Transceivers

Best in Class 5V Performance
Largest 3.3V Portfolio in Industry

3.3V Supply

Standby Power

Improved EMI

Isolated

Redundant CAN

Fault Protected

2Mbps CAN FD

5Mbps CAN FD

End Applications for CAN

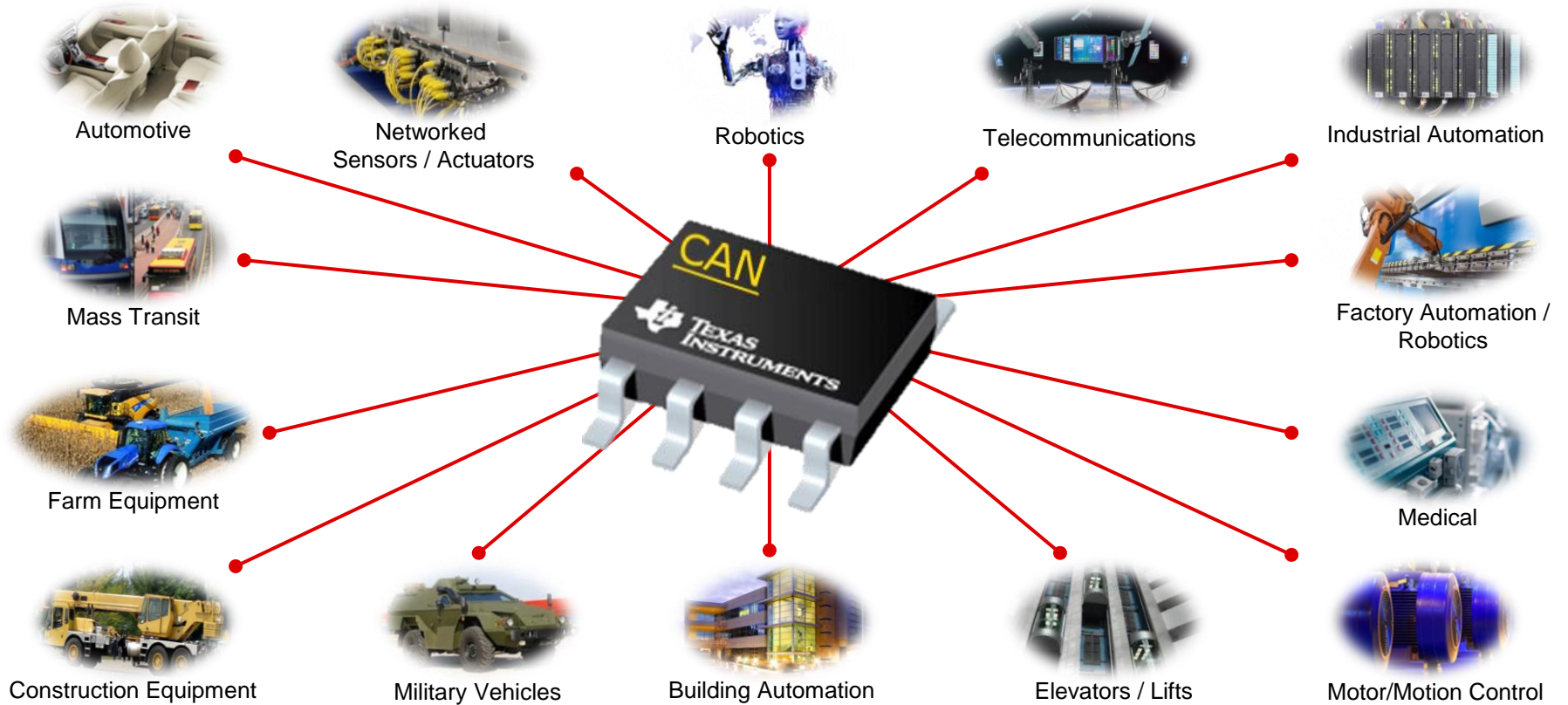

3.3V CAN Transceivers

Top 5 reasons to move to 3.3V CAN

1. Customers and uC providers are quickly moving to 3.3V solutions
2. 3.3V and 5V CAN transceivers are fully interoperable
3. Reduce BOM, board space and cost
4. At least 33% less power consumption
5. 3.3V package pinouts are compatible with 5V devices

3.3V CAN Portfolio

Feature Device	SN65HVD230 SN65HVD231 SN65HVD232	SN65HVD233 SN65HVD234 SN65HVD235	TCAN330 TCAN332 TCAN334 TCAN337	TCAN330G TCAN332G TCAN334G TCAN337G
CAN / CAN FD	CAN	CAN	CAN	CAN FD ★
Data Rate	1Mbps	1Mbps	1Mbps	5Mbps ★
Common mode range	-2 to 7V	-7 to 12V	-12 to 12V	-12 to 12V ★
Bus pin fault protection	-4 to 16V	-36 to 36V ★	-14 to 14V	-14 to 14V
ESD protection	±16kV HBM	±16kV HBM	±25kV HBM	±25kV HBM ★
IEC-61000-4-2 ESD (C/D)	N/A	N/A	±12kV	±12kV ★
Enhanced features	Slope Control	Slope Control, Loopback, Autobaud,	Short Prop Delay, Fault Indication	Short Prop Delay, Fault Indication ★
Low Power Modes	Standby, Sleep, or none	Standby, Sleep	Silent, Standby, Shutdown	Silent, Standby, Shutdown
Temperature	-40 to 125C (Q)	-40 to 125C	-40 to 125C	-40 to 125C ★
Automotive Qualified	✓	✓		
Package	8-pin SOIC (5x4mm)	8-pin SOIC (5x4mm)	8-pin SOIC (5x4mm) 8-pin SOT23 (3x3mm)	8-pin SOIC (5x4mm) 8-pin SOT23 (3x3mm) ★

TCAN330 / 332 / 334 / 337

3.3V Industrial CAN Transceivers

Features

- ISO 11898-2 Compatible
- Common-Mode Range: $\pm 12V$
- Speed: 1Mbps (standard), 5Mbps (optional)
- Protection Features:
 - $\pm 14V$ Bus-Fault Protection
 - $\pm 25kV$ HBM ESD Protection
 - $\pm 12kV$ IEC61000-4-2 Contact Discharge
- Specialized Modes:
 - TCAN330: Shutdown and Silent Modes
 - TCAN332: Normal Mode Only
 - TCAN334: Shutdown and Standby with Wake Modes
 - TCAN337: Silent Mode
- Special Features: FAULT output pin for fault indication to host processor (TCAN337)
- RXD & TXD Dominant State Time Outs
- Temperature Range: -40° to $+125^{\circ}C$
- Packages:
 - SOT23-8 (3mm x 3mm)
 - SOIC-8 (5mm x 6mm)

Applications

- “Classic CAN Applications”: Supports CAN
- Telecom & Backplanes
- Factory Automation / Control
- Smart Grid
- Building Automation

Benefits

- Direct interface to 3.3V MCU's and DSPs with simplified system voltage rails and regulation design
- 3.3V CAN requires less power and excellent for low power applications while still monitoring the bus
- EMC Performance yields high reliability in harsh environments
- Wide temp. range to accommodate harsh industrial environment
- Small footprint SOT-23 package saves >70% PCB space
- Footprint Replacement to MAX3051

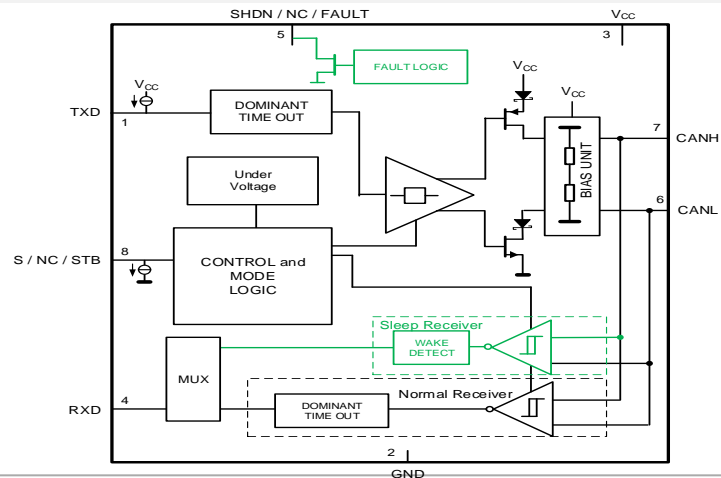

5V CAN Transceivers

5V CAN Portfolio

Feature Device	TCAN1042	TCAN1051	SN65HVD25x	SN65HVD1040 SN65HVD1040A	SN65HVD1050 SN65HVD1050A
CAN / CAN FD	CAN FD	★ CAN FD	CAN - Turbo	CAN	CAN
Data Rate	2Mbps or 5Mbps	★ 2Mbps or 5Mbps	1Mbps	1Mbps	1Mbps
Common mode range	-30 to 30V	★ -30 to 30V	-7 to 12V	-12 to 12V	-12 to 12V
Bus pin fault protection	±58 or ±70V	★ ±58 or ±70V	from -36 to 40V	-27 to 40V	-27 to 40V
ESD protection	±16kV HBM	★ ±16kV HBM	up to ±14kV HBM	±12kV HBM	±4kV HBM
IEC-61000-4-2 ESD	±15kV	★ ±15kV	up to ±8kV	±6kV	N/A
Enhanced features	Bus wake up, EMC performance	★ Short prop delay, EMC Performance	Slope control, VIO/Vref Pins	Bus wake up, VIO pin (V)	Time-out circuit, VREF pin
Low Power Modes	Standby	Silent	Silent	Silent, Standby	Silent
Temperature	-55 to 125C	-55 to 125C	from -40 to 125C	-40 to 125C	from -55 to 125C
Automotive Qualified	✓	✓	✓	✓	✓
Package	8-pin SOIC (5x4mm) 8-pin VSON (3x3mm)	★ 8-pin SOIC (5x4mm) 8-pin VSON (3x3mm)	8-pin SOIC (5x4mm) 8-pin PDIP (10x6mm)	8-pin SOIC (2.6 x 5mm)	8-pin SOIC (5x4mm)

TCAN1042H / TCAN1042-Q1

Fault Protected CAN Transceiver With Flexible Data-Rate and Bus Wake Up

Features

- ISO 11898-2 and -5 compliant and Draft CAN FD
- Signaling Rate Optimized for up to: 2Mbps, 5Mbps (G)
- DC Bus-Fault Protection: $\pm 58V$, $\pm 70V$ (H)
- Common mode range: $\pm 30V$
- Fast Loop Times: $< 175ns$
- V_{IO} Output Supply: 2.8 to 5.33V (V)
- $\pm 16kV$ HBM ESD and $\pm 15kV$ IEC for bus pins
- Low Power Standby Mode: 5 μA , 22 μA (w/ V_{IO})
- TXD dominant state time out
- Under-voltage Protection and Thermal Shutdown
- Temperature Range: -55 to $+125^{\circ}C$
- Package: 8-SOIC (5mm x 4mm) / 8-VSON (3mm x 3mm)

Applications

- Body Electronics
- Power Train
- Infotainment / ADAS
- Building and Factory Automation
- Smart Grid
- Communications Infrastructure

Benefits

- Common Mode Choke not required (per OEM)
- Wide V_{CC} Range (4.5V to 5.5V) for start/stop w/out boost
- Wide I/O voltage level adapting reduces external components
- Extended Bus-Fault Protection supporting 48V systems
- Hot swap support w/ glitch free bus I/O on power-up/ down
- Industry Standard Packaging: P2P compatible

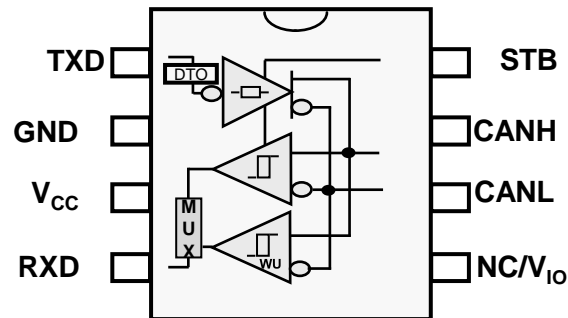

TCAN10xxHGV

xx = numerical part number

H = $\pm 70V$ Bus Fault Protection

G = 5Mbps Flexible Data Rate Capable

V = 3V Level Shifter Integrated (V_{IO} pin)

TCAN1051H / TCAN1051-Q1

Fault Protected CAN FD Transceiver with Ultra-Low Power Silent Mode

Features

- ISO 11898-2 and -5 compliant and Draft CAN FD
- Signaling Rate Optimized for up to: 2Mbps, 5Mbps (**G**)
- DC Bus-Fault Protection: $\pm 58V$, $\pm 70V$ (**H**)
- Common mode range: $\pm 30V$
- Fast Loop Times: $< 175ns$
- V_{IO} Output Supply: 2.8 - 5.33V (**V**)
- $\pm 16kV$ HBM ESD and $\pm 15kV$ IEC for bus pins
- Ideal Passive: High impedance I/Os when unpowered
- TXD dominant state time out
- Under-voltage Protection and Thermal Shutdown
- Temperature Range: -55° to $+125^{\circ}C$
- Package: 8-SOIC (5mm x 4mm) / 8-VSON (3mm x 3mm)

Applications

- Body Electronics
- Power Train
- Infotainment / ADAS
- Building and Factory Automation
- Smart Grid
- Communications Infrastructure

Benefits

- Common Mode Choke not required (per OEM)
- Wide VCC Range (4.5V to 5.5V) for start/stop w/out boost
- Wide I/O voltage level adapting reduces external components
- Extended Bus-Fault Protection supporting 48V systems
- Hot swap support w/ glitch free bus I/O on power-up/ down
- Industry Standard Packaging: P2P compatible

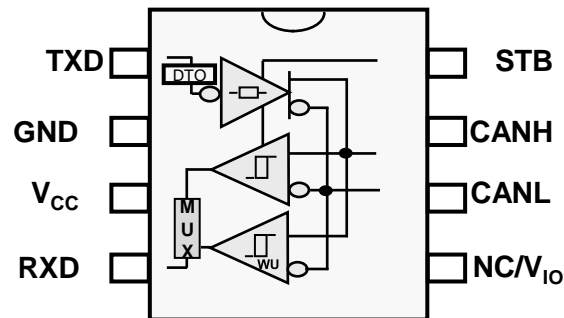

TCAN10xxHGV

- xx** = numerical part number
- H** = $\pm 70V$ Bus Fault Protection
- G** = 5Mbps Flexible Data Rate Capable
- V** = 3V Level Shifter Integrated (V_{IO} pin)

Automotive CAN Transceivers

TCAN1042 / TCAN1051

Fault Protected 5V CAN with CAN FD (Flexible Data Rate)

- **New** 5V CAN Transceivers
 - Industry leading performance
 - Pin-to-Pin compatible with leading solutions from TI and Competitors
- TCAN equals TI's new CAN transceiver families
 - Consists of two base part numbers in the 5V family
 - TCAN1042 and TCAN1051
 - AEC Q100 qualified devices (Automotive End-Equipment)
 - Automotive devices are identified by having Q1 in the orderable part number (e.g. TCA
 - Industrial grade devices (i.e. non AEC Q100) or part numbers that do not contain Q1 (e.g.

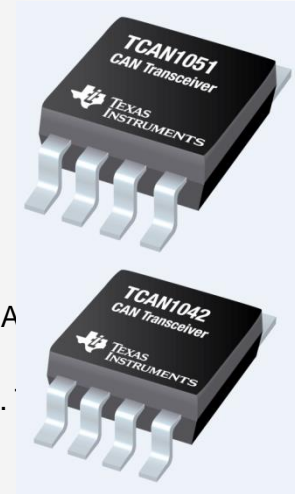

TCAN1042 vs TCAN1051

Primary Differences

• TCAN1042

- Includes low power standby-mode with bus wake-up capability
- Low power standby: **5uA max** (w/ V_{IO} pin), 22uA max (w/o V_{IO} pin)
 - Transmitter is turned **OFF**
 - Main Receiver is turned OFF
 - Low power Wake-Up Receiver is turned ON
 - Allows the device to return to active mode if there is any activity on the CAN bus by monitoring V_{CC}
 - For V versions of the device (using V_{IO}), V_{CC} can be turned off in standby-mode as the V_{IO} is powered from V_{IO}
- Applications: battery powered applications

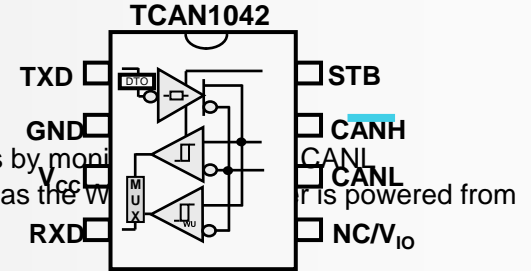

• TCAN1051

- Includes a silent-mode instead of standby
- Silent mode is sometime referred to as 'listen only' or 'receive only' mode
- Silent mode: **2.5mA**
 - Transmitter is turned OFF
 - Receiver is **turned ON**
 - There is no low power wake-up receiver
- Applications: wall powered operations

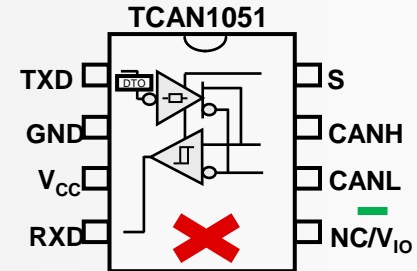

Industry Standard Package

8-pin SOIC (8D) and 8-pin HVSON (8DRB)

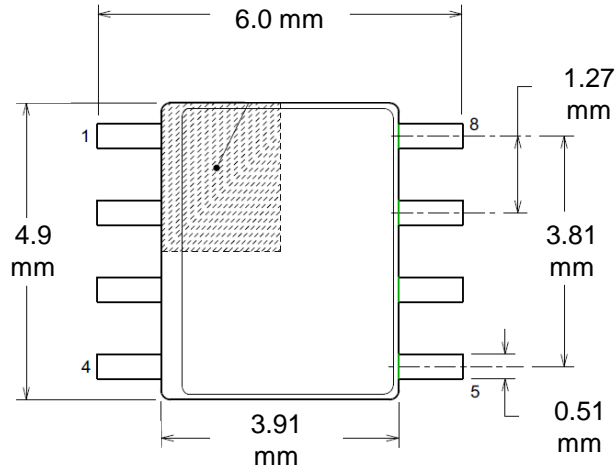

Footprint: 29.4 mm²
Body: 19.16 mm²
Pitch: 1.27 mm
Lead width: 0.51mm

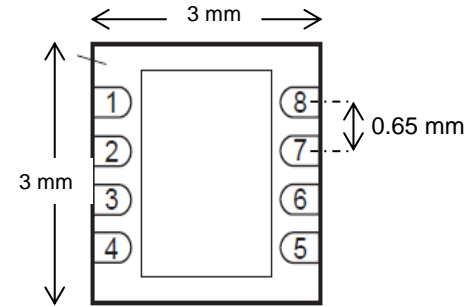

Footprint: 9 mm²
Body: 9 mm²
Pitch: 0.65 mm
Ground Pad: 4.8 mm²

Pin-to-Pin Compatible with Competitive Solutions

TCAN1042-Q1 / TCAN1051-Q1

± 70V CAN XCVRs with optional Bus Wake Up and Flexible Data (FD)

Features

- ISO 11898-2 and -5 compliant **and** Draft CAN FD
- Signaling Rate Optimized for up to:
 - Standard: 2Mbps
 - CAN FD: 5Mbps (“G” Version)
- DC Bus-Fault Protection: ±58V, ± 70V (“H”)
- Common mode range: ±30V
- Fast Loop Times: <175ns
- V_{IO} Supply: 2.8 - 5.5V (“V” version)
- Ultra-Low Power Standby Mode with Bus Wakeup (TCAN1042)
- Low Power Silent Mode (TCAN1051)
- ±16kV HBM ESD and ±15kV IEC for bus pins
- Ideal Passive – High impedance I/Os when unpowered
- TXD dominant state time out
- Under-voltage Protection
- Thermal Shutdown
- Package: 8-SOIC (D) 5mm x 4mm and 8-VSON (DRB) 3mm x 3mm

Applications

- Body Electronics
- Power Train
- Infotainment / ADAS
- Building Automation
- Factory Automation

Benefits

- Common Mode Choke not required (per OEM)
- Wide V_{CC} Range (4.5V to 5.5V) for start/stop w/out boost
- Wide I/O voltage level adapting reduces external components
- Extended Bus-Fault Protection supporting 48V systems
- Hot swap support with glitch free bus I/O on power-up / down
- Industry Standard Packaging: P2P compatible

TCAN10xxHGV

xx = numerical part number

H = ±70V Bus Fault Protection

G = 5Mbps Flexible Data Rate Capable

V = 3V Level Shifter Integrated (V_{IO} pin)

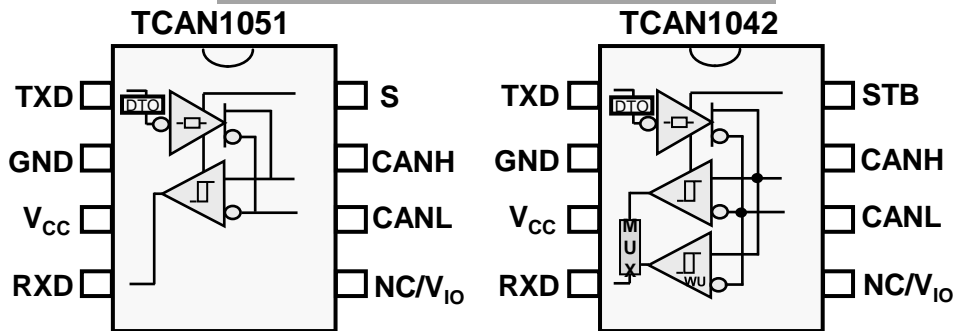

TCAN Ideal for Automotive and Industrial Applications

High Immunity: Deterministic communication in electromagnetic noisy applications

Low Emissions: Reduced electromagnetic noise emission enabling more reliable system communications

Automotive: Communicate while switching on GPS
Industrial: Communicate while switching on AC motor in Motor Drive applications

Automotive: Reduce interference with radio
Industrial: Reduce interference with communications equipment

Radiated Emissions (0.5Mbps) Comparison

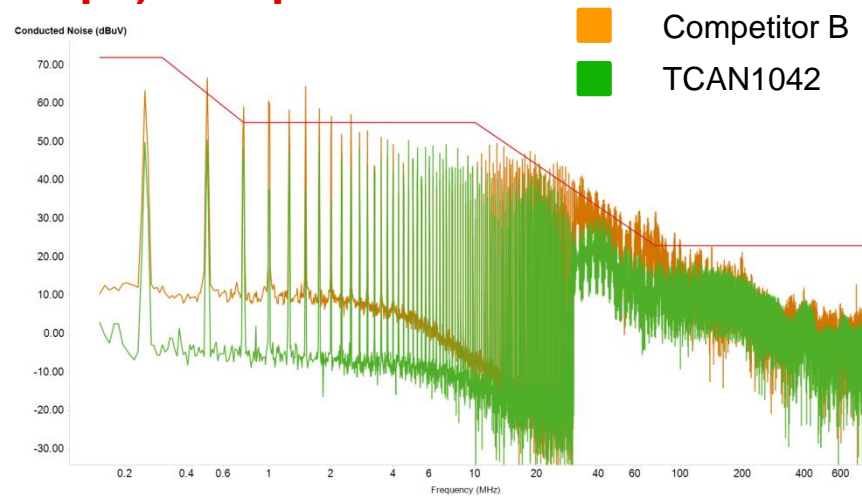
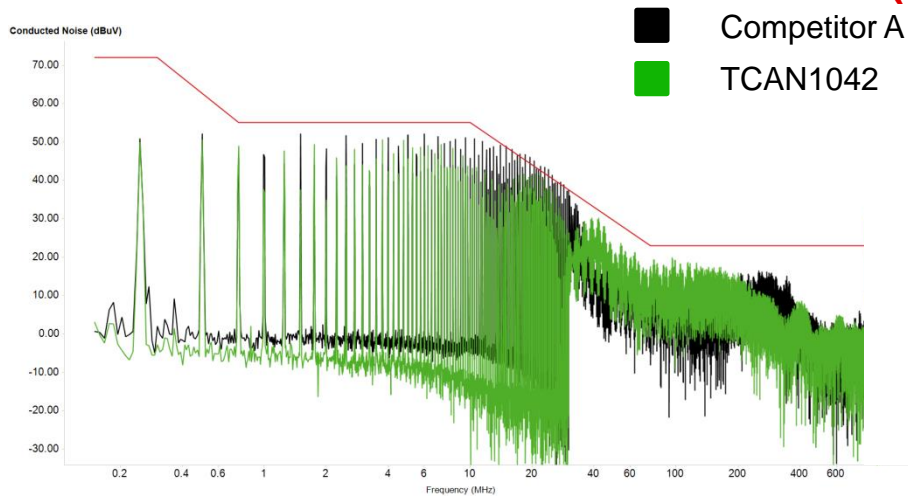

29

Design Resources

Evaluation Boards and Reference Designs

Evaluation Modules (Schematics, Layout, and BOM)

- **TCAN332D CAN EVM** ([TCAN332DEVM](#))
 - 3.3V CAN
 - Dual Site Industrial EVM
- **TCAN1042D CAN EVM** ([TCAN1042DEVM](#))
 - 5V CAN
 - CAN FD (2Mbps)
- **SN65HVD255 CAN EVM** ([SN65HVD255DEVM](#))
 - General CAN EVM – HVD255 pre-installed
 - Configurable to support all TI SN65HVD25x, HVD23x and HVD10x0 CAN transceivers
- **SN65HVD257 CAN EVM** ([SN65HVD257EVM](#))
 - 2x HVD257 installed and EVM configured to support redundant / parallel CAN networks
 - Configurable to support 2 independent CAN channels
- **ISO1050 Isolated CAN EVM** ([ISO1050EVM](#))

TI Reference Design Schematics and Links

- Sitara™ AM3359 Industrial Communications Engine (ICE)
- Hercules™ TMS570LS31x Development Kit

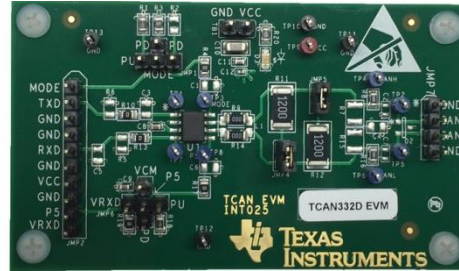

TCAN332D EVM
(Dual Site Industrial
CAN EVM)

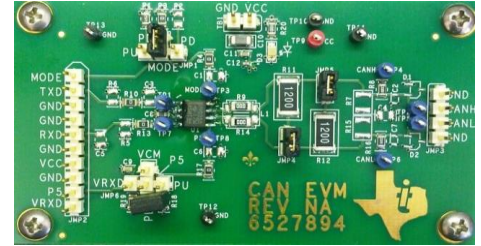

SN65HVD255 EVM
(General CAN EVM)

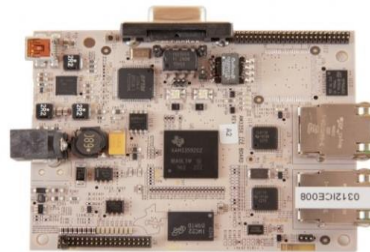

**AM3359 Industrial
Communications Engine (ICE)**

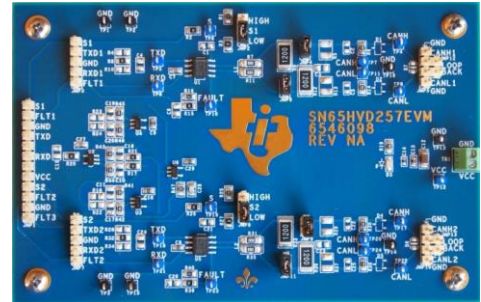

SN65HVD257 EVM
(Redundant CAN and 2 CAN
channel EVM)

Resources: www.ti.com/can

- Design Resources:
 - Selection Tables
 - Application Notes
 - Evaluation Boards
 - Reference Boards
 - Competitor Cross Ref
 - Models
 - Videos
 - and more!

TI Home > Interface > CAN Transceivers

Interface

Product Tree

- Isolation
 - Digital Isolators (121)
 - Isolated RS-485 Transceivers (10)
 - Isolated CAN Transceivers (1)
 - Isolated I2C (2)
 - Isolated Gate Driver (14)
 - Transformer Driver (4)
- CAN Transceivers (84)**
- Display & Imaging SerDes (164)
 - DVI/HDMI (12)
 - CSI/DSI (10)
 - DisplayPort (19)
 - FPD-Link II SerDes (25)
 - FPD-Link III SerDes (36)
 - Ethernet/SDP Link (MDC for LCD)

Overview for CAN Bus Transceivers

Controller Area Network (CAN) is a robust multi master-master, differential signaling, serial communications bus specified by the ISO 11898 family of standards. TI's industry-leading transceivers solve specialized networking requirements for various applications and power supply systems, providing solutions for 5 Volt, 3 Volt operation as well as CAN FD (Flexible Data rates); simplifying complex CAN bus networked systems. TI can transceivers also support higher layer protocols such as CANopen (EN 50325-4), DeviceNet, SAE J1939, ISO 11783, and many others.

- Broad Portfolio**
 - Wide variety of parts
 - Multiple operating voltages
 - Automotive and industrial grades
 - Multiple packages
- 3.3 Volt CAN Bus**
 - Single 3 Volt operating voltage
 - Low voltage alternative to 5 Volt transceivers
 - Interoperable with 5 Volt mixed networks
 - Industry's first 3.3V CAN transceiver
- Automotive CAN Bus**
 - Designed for automotive applications
 - Q100 qualified CAN transceivers
 - Multiple power modes

Delivering **MORE** Together - TI's Engineer to Engineer Community:
<http://e2e.ti.com>

Power over Ethernet Premiere TIDesigns

Power Over Ethernet

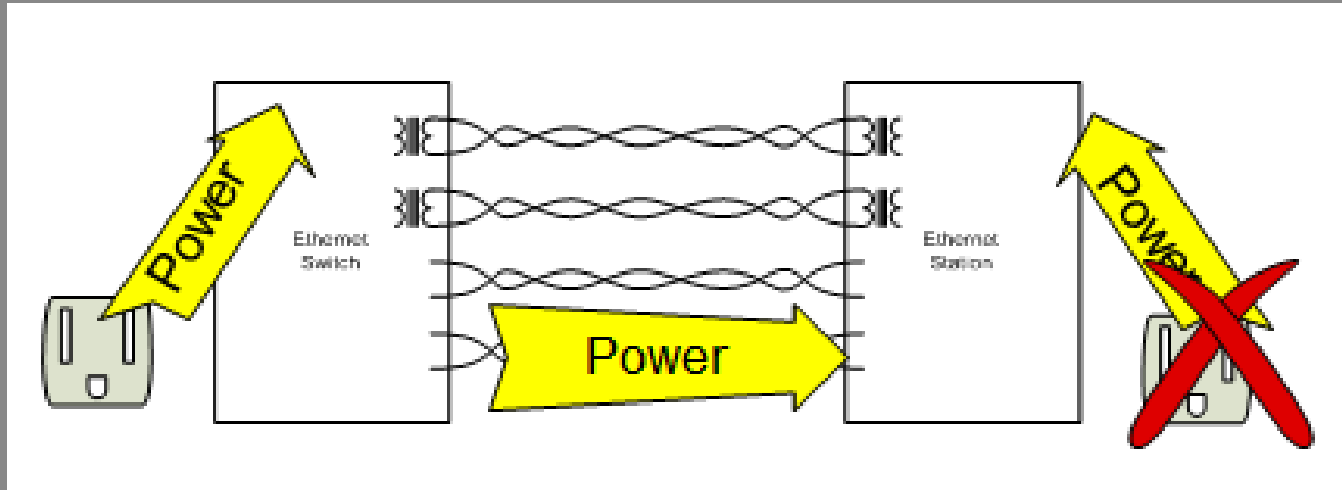

TIDA-00741:

Non-Standard, UPOE 51W High-Efficiency Flyback Converter Reference Design for PoE PD Applications

Why “copy & paste” this Design?

- Interoperable with Cisco UPOE Switch
- Small solution size
- High efficiency

What are the Top Technical Features?

- Forced 4-Pair UPOE (51W)
- Excellent efficiency, driven, synchronous flyback design
- 92% high efficiency (converter only)

Who should use it?

- Universal Power Over Ethernet (UPOE) Compliant Devices
- Video and VoIP telephones
- Multiband access points
- Security cameras
- Pico-base stations

TI Parts	Vin	Po	Vo/Io	Topology	Avg. Eff.
TPS2378, TL431A, CSD18504Q5A, TL7700	42.5~57 V	25.5W	12V/2.125A	Flyback	Up to 92%

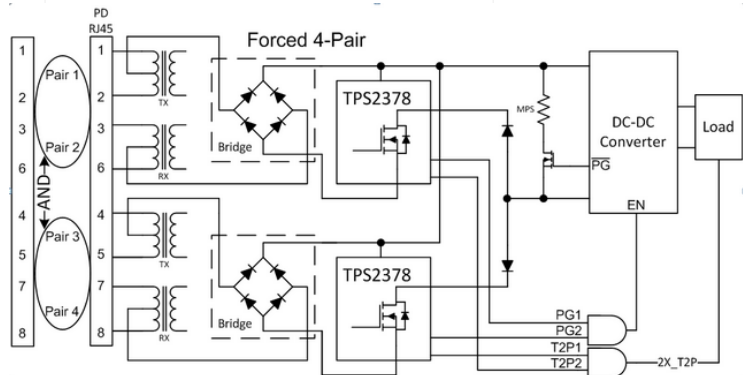

TIDA-0741 Efficiency (48V)

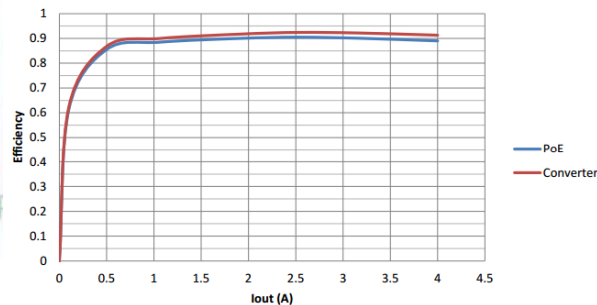

PMP8803:

IEEE802.3at Type 1 Class 3 - Low Cost 12V/1A Flyback Converter for PoE Applications

Why “copy & paste” this Design?

- Maximize efficiency at low cost
- Integrated solution
- Small solution size
- Back up power source with ac-dc adaptor

What are the Top Technical Features?

- Class 3 PoE application
- Non-sync flyback topology
- TPS23753A integrated PD+PWM IC
- Up to 90% efficiency
- Auxiliary adaptor input

Who should use it?

- IP Camera
- WIFI AP
- IP Phone

TI Parts	Vin	Po	Vo/Io	Topology	Avg. Eff.
TPS23753A, TL431A	36~57 V	12W	12V/1A	Flyback	Up to 90%

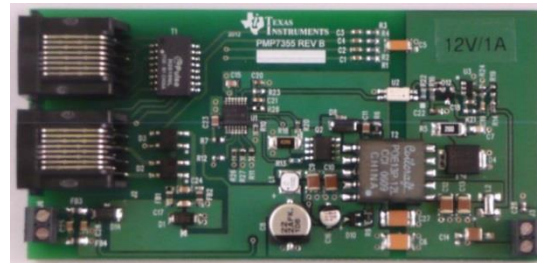
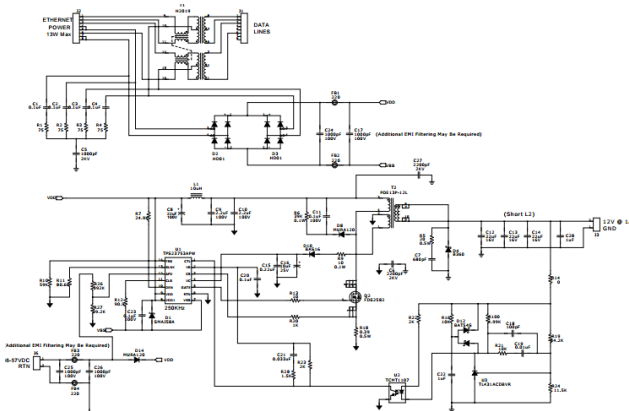

PMP8803 Rev A Efficiency

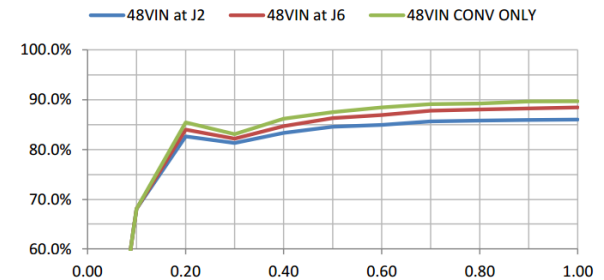

PMP9175:

IEEE802.3at Type 1 Class 3 - 5V/2.3A High Eff Sync Flyback Converter w/ FET Bridge for PoE Applications

Why “copy & paste” this Design?

- Maximize efficiency
- Integrated solution
- Small solution size
- Back up power source with ac-dc adaptor

What are the Top Technical Features?

- High efficiency w/active bridge & sync rect
- Isolated 5V/2.3A Output
- Small size solution
- TPS23753A integrated PD+PWM IC
- Up to 90% efficiency
- Auxiliary adaptor input

Who should use it?

- IP Camera
- WIFI AP
- IP Phone

TI Parts	Vin	Po	Vo/Io	Topology	Avg. Eff.
TPS23753A, TLV431A, CSD17527Q5A, CSD17551Q3A	36~57 V	11.5W	5V/2.3A	Flyback	Up to 90%

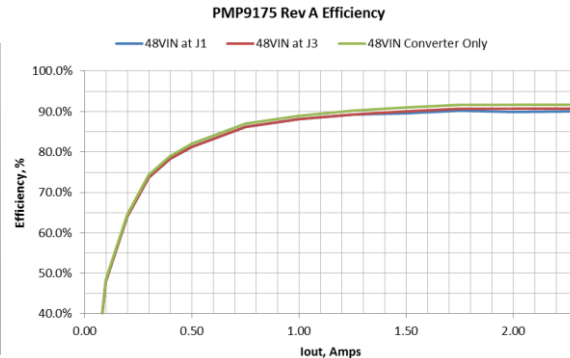
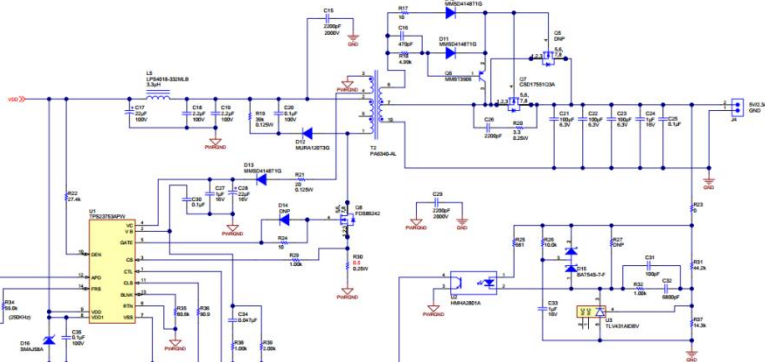

PMP11254:

IEEE802.3at Type 2 Class 4 PoE Flyback Converter (12V@2.125A) for PoE Applications

Why “copy & paste” this Design?

- Maximize efficiency with sync rectification
- Integrated solution
- Small solution size
- Back up power source

What are the Top Technical Features?

- Class 4 PoE application
- Non-sync flyback topology
- TPS23751 integrated PD+PWM IC
- Up to 91% efficiency

Who should use it?

- IP Camera
- WIFI AP
- IP Phone

TI Parts	Vin	Po	Vo/Io	Topology	Avg. Eff.
TPS23751, TL431A	42.5~57 V	25.5W	12V/2.125A	Flyback	Up to 91%

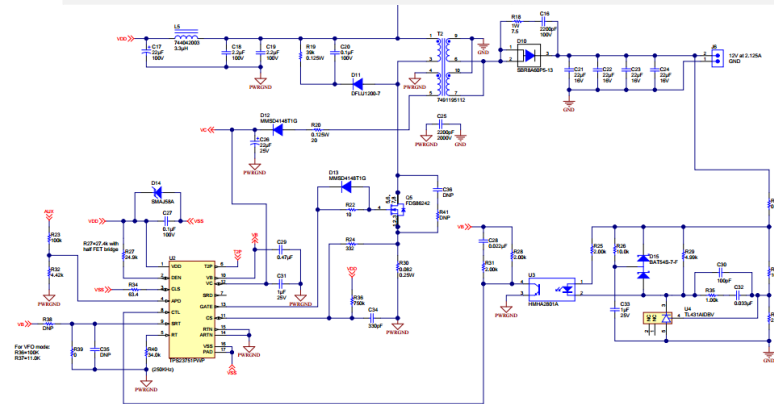

PMP11254 Rev D Efficiency, 48V Input

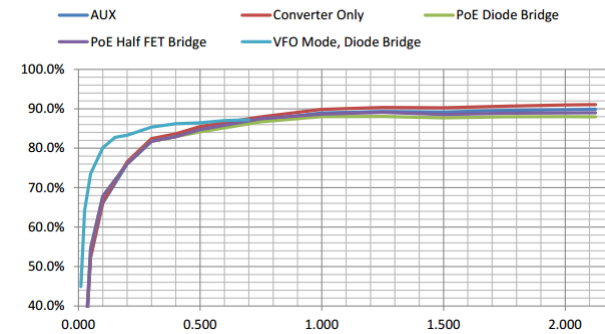

TIDA-00617:

IEEE802.3at Type 1 Class 4 High-Efficiency Driven Flyback Converter (5V/5A) for PoE PD Applications

Why “copy & paste” this Design?

- High efficiency
- Small size
- No sync rect winding at transformer
- Backup power source with ac-dc adaptor

What are the Top Technical Features?

- Excellent efficiency, driven, synchronous flyback design.
- Gigabit Ethernet pass through interface
- 24V and 48V adapter input capability
- 5V @ 5A DC output

Who should use it?

- IEEE802.3at compliant devices
- Video and VoIP Telephones
- Multiband Access Points
- Security Cameras
- Pico-base stations

TI Parts	Vin	Po	Vo/Io	Topology	Avg. Eff.
TPS23751, TLV431A, CSD18504Q5A	21.6~57 V	25W	5V/5A	Isolated Sync Flyback	Up to 92%

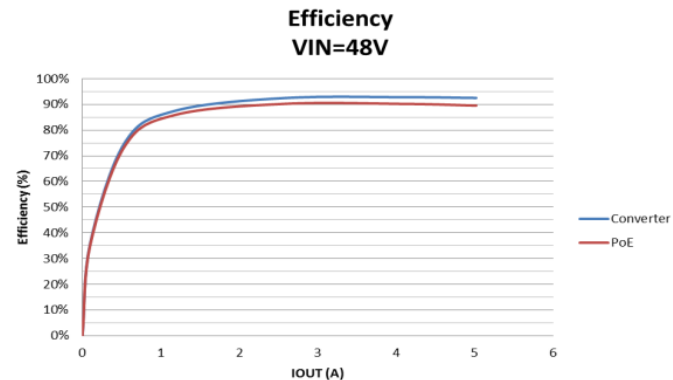
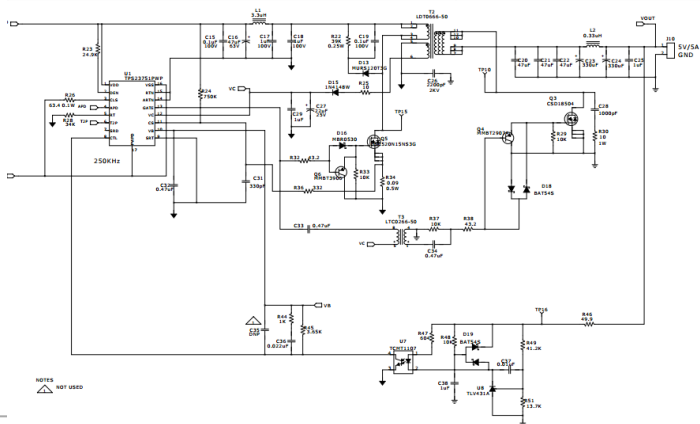

TPS23861EVM-612:

PoE PSE Type 2 (30W) IEEE 802.3at Fully Autonomous Quad Port Solution

Why “copy & paste” this Design?

- Ease of use
- Double-sided PCB design
- Best interoperability
- Easy multiplied to 8-, 12-,16-port and so on

What are the Top Technical Features?

- Full autonomous mode so no digital interface is required
- Passes UNH-IOL PoE Conformance/Interoperability and SIFOs Type 1/Type 2 Test Suites
- Four IEEE802.3at, Type 2 (30 W) ports and Two non-standard, high power (<60W) ports supported
- PC-based-GUI, or Microcontroller based code Programming

Who should use it?

- Backhaul - Microwave backhaul
- Ethernet Switch
- Power Over Ethernet (PoE)
- Video Recorder (NVR, DVR, etc.)

TI Parts	Vin	Po
TPS23861, ISO7241C, LM5019	44-57 V	28.8W

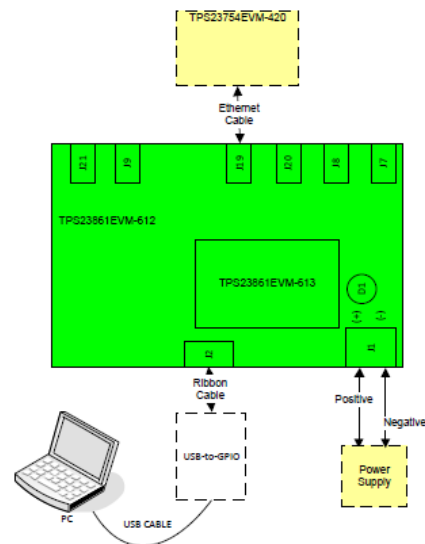

TIDA-00465:

Single Port, Power-over-Ethernet, Type 2 Auto-Mode PSE

Why “copy & paste” this Design?

- Ease of use
- Double-sided PCB design
- Best interoperability
- Small form factor

What are the Top Technical Features?

- TPS23861 IEEE 802.3at PSE Controller
- Single Port 30W PoE Injector
- Auto Detection and Classification of PD
- Auto Turn on and Disconnect of PD
- Requires only 48VDC, 40W AC-DC Adapter

Who should use it?

- Avionics: Engine Control/Monitoring
- Backhaul - Microwave backhaul
- Power Over Ethernet (PoE)
- STB, DVR & Streaming Media

TI Parts

TPS23861, ISO7241C,
TPS7A4001

Vin

44-57 V

Po

28.8W

