

## DRIVING VIDEO OUTPUT STAGES WITH MONOLITHIC INTEGRATED AMPLIFIERS

By Christian Henn, Burr-Brown International GmbH

Increasingly powerful computers and the rapidly expanding use of picture processing and CAD/CAM systems in almost all industry branches have combined to generate a greater and greater demand for higher resolution graphic monitors. Controlling the video output stages of these graphic monitors is a key to producing such high resolutions. Until recently, only highly complex, expensive systems have been available to drive hybrid video output stages. But using the monolithic amplifiers OPA623 and OPA2662 from Burr-Brown, new methods are possible that make complicated solutions a thing of the past. The OPA623 allows rise ( $t_{RISE}$ ) and fall ( $t_{FALL}$ ) times of 3ns and 2.3ns, respectively, at the output, while the OPA2662 is even more impressive at  $t_{RISE} = 2.4ns$  and  $t_{FALL} = 2.15ns$ . With this kind of performance, the OPA623 and OPA2662 can be used in graphic systems with resolutions of 1600 x 1200 pixel and more.

### HIGH-RESOLUTION PICTURE PROCESSING SYSTEMS: AN OVERVIEW

The various standard resolutions range from the commonly used VGA standard with 640 x 400 pixels to the super VGA with 800 x 600 pixels to CAD/CAM and radar systems with over 1600 x 1200 pixels. But while radar and computer tomography systems generally use high-resolution 1600 x 1200 color graphic monitors, monochrome displays with 2k x 2k resolution and 500MHz bandwidth are now in development. To achieve such high resolutions, the monitors use horizontal deflection frequencies for electron rays between 64kHz and 96kHz, as well as data rates between 100Mbit/s and 250Mbit/s, which are read out from the video RAM card. Raising the vertical deflection frequency to more than 70Hz causes the horizontal frequency and data rate to increase while the resolution remains the same. Controlling the pixels by the video controller adds to the demands on the video amplifier, and significantly increases the power consumption during video signal processing. Instead of a continuous video signal, the video card produces pulse sequences that return to zero between every two pulses. The amplitude of each pulse is equal to the luminance of the respective color (R, G, B). An additive optical mixing

process produces the correct color on the screen. For this reason, displaying the color white at the maximum amplitude is the toughest job for the video amplifier in graphic monitors.

Table I summarizes the various timing requirements necessary to produce the most commonly used graphic formats. The  $T_{H\ ACTIVE}$  can be calculated by multiplying the horizontal cycle time by 0.8, and it includes time for the electron ray to return from the right side to the left side of the screen during the horizontal retrace time. When calculating  $t_{RISE}$  and  $t_{FALL}$ , it was assumed that each was one third of the pixel time. The  $-3dB$  bandwidth ( $f_{-3dB}$ ) is dependent upon the rise time and can be calculated as  $0.35/t_{RISE}$ .

The video signal levels at the interface between the video card and monitor are standardized at +0.7Vp for the video signal and -0.3Vp for the synchronization pulse. A high-resolution cathode ray tube (CRT) functions with bias voltages between +65V and +75V and a modulation voltage of

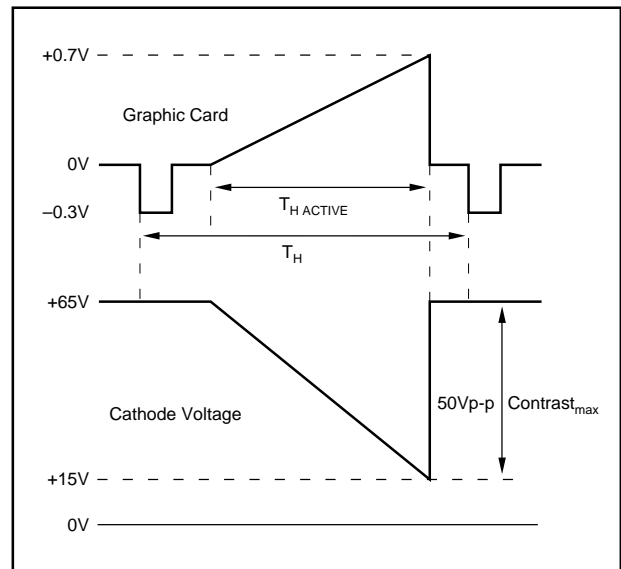

FIGURE 1. Pulse Sequences from a Signal Graphic Cathode.

SYSTEM STANDARDS	RESOLUTIONS H x V	$f_H$ (Hz)	$f_V$ (Hz)	$t_H$ ( $\mu s$ )	$t_{ACTIVE}$ (ns)	TIME/PIXEL (ns)	PIXEL/CLOCK FREQUENCY (Hz)	$t_{RISE/FALL}$ (ns)	$-3dB$ BW (Hz)
VGA	640 x 400	31.5k	70	31.74	25.39	39.67	25M	13.22	26.47M
Super VGA	800 x 600	38k	70	26.31	21.04	26.30	38M	8.76	40M
CAD/CAM	1280 x 1024	64k	60	15.62	12.49	9.75	102M	3.25	107M
Work Station	1600 x 1200	76k	70	13.15	10.52	6.57	152M	2.19	160M

TABLE I. Timing Requirements.

up to 50Vp-p with high luminance densities between the cathode and ground. For sufficient contrast, the total gain between the input and cathode must be between 70 and 166, depending upon the contrast control method in use. The cathode is a capacitive load of about 8pF, which rises to at least 12pF when combined with stray capacitances from the supply lines, connectors, and required protection circuitry.

Gain	70 to 166
Output Amplitude	50V <sub>MAX</sub>
t <sub>RISE</sub> /t <sub>FALL</sub> (40V, 12pF)	2ns
Driver Current	±300mA <sub>p-p</sub>
Slew Rate	25000V/μs
Linearity	1%

TABLE II. Video Output Stage Requirements for a 1600 x 1280 Graphic System.

### VIDEO AMPLIFIER CONCEPT

Since the development of the first monitors, various types of amplifiers have been designed according to specific requirements and applications. The type of amplifier structure shown in Figure 2 has become the standard for high-grade monitors.

The amplifier at the front end of the circuit is equipped with a simple transconductance multiplier to control the signal. Since this type of multiplier has a small linear modulation range, it is necessary to reduce the signal in the amplifier from 0.7Vp to 0.3Vp. The following driver stage amplifies the signal 8 to 15 times and drives the output stages at approximately 4Vp-p. The output stage then amplifies the signal again to 50Vp-p max and provides the necessary driving power to charge the cathode and stray capacitances. At the back porch that occurs at the beginning of each line after the horizontal switch, the control circuit compares the cathode voltage to an adjustable bias and corrects any deviations from the bias. Depending on the type of amplifier structure, the bias point control drives either the input of the driver amplifier or the output stage. The entire video amplifier then reverses the video signal. A 0V signal at the input, which appears as a dark spot, is converted at the cathode to a voltage between +65V and +75V, depending upon the bias point of the cathode. A +0.7V signal, which corresponds to maximum luminance, is converted with maximum contrast control to a 50V modulation hub between the CRT bias point and ground. Figure 1 illustrates these conversions.

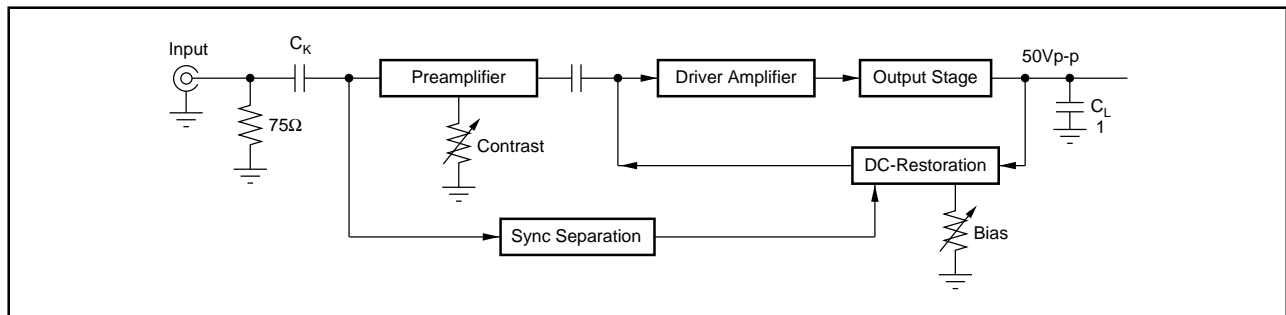

FIGURE 2. Video Output Stage Requirements for a 1600 x 1280 Graphic System.

### VIDEO OUTPUT STAGE

Until a few years ago, the standard circuit for video output stages was a cascode stage with or without a subsequent complementary emitter follower. The advantages of this circuit are that it is easy to design and avoids the Miller effect (harmful collector-base capacitances) in the amplifying transistor. Inductances in series to the collector resistor and RC parts parallel to the emitter resistor allow users to adjust the circuit as required by their particular application. The disadvantages of the cascode stage are its asymmetrical transient response and high power dissipation at short rise and fall times.

We conducted several experiments with various configurations to test the ability of the OPA623 and OPA2662 to control a discrete cascode stage. As shown in Figure 3, a few of these configurations failed because there are no discrete cascode transistors effective for this application. The integrated dual current source OPA2662 can produce a charge current of up to 300mA in the emitter of a transistor like the BFQ262 at rise times of about 2ns, but internal transistor and emitter resistances and any package stray capacitances limit and delay the current conversion from the emitter to the collector of the BFQ262.

Further tests were done using an output stage manufactured on a hybrid process, and these tests were successful. Figure 6 shows the schematic of the output stage, which is available from Philips under the part number CR3425. Using the test configuration shown in Figure 7, it was possible to check the performance of the hybrid circuit by itself. The pulse generator HP8130A drives the output stages via a terminated 50Ω line with rise and fall times of 0.7ns each and a signal amplitude of 4Vp. The output stage is supplied from 80V, and 60mA quiescent current flows when no signal is being applied. The rise and fall times measured at a 50V signal hub and 12pF load capacitance are impressively low at 2.15ns. Figure 8 shows the pulse responses at 10ns/div and 2ns/div.

### AN ALTERNATIVE METHOD OF DRIVING THE OUTPUT STAGE

With the hybrid circuit CR3425, a cost-effective, high-performance circuit is now available for high-resolution graphic monitors that effectively controls the output of the video output stage. Now, however, the problem is controlling the input of the video output stage. What we need is a

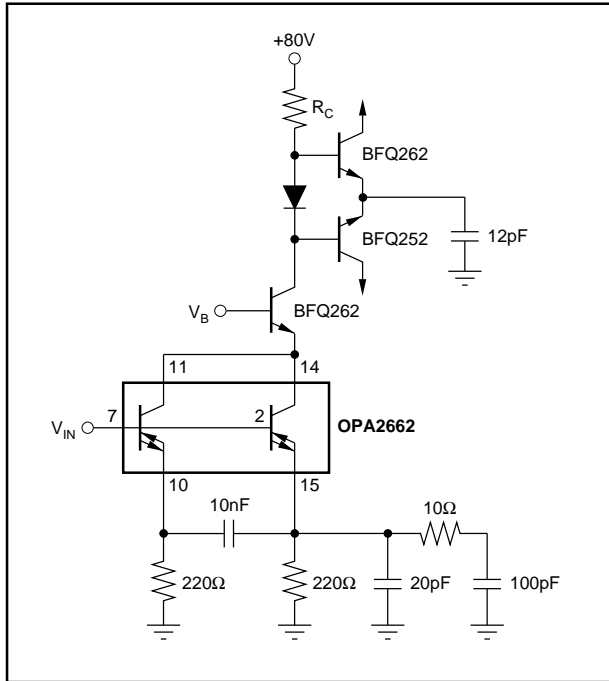

FIGURE 3. Video Output Stage.

driver amplifier that takes the pulse after contrast control and amplifies it with no edge slopes, as well as controlling the complex input resistance in the output stage with a slew rate of over  $1500\text{V}/\mu\text{s}$  for positive and negative signal transitions. The hybrid driver amplifiers currently on the market function only with NPN transistors in class A operation. Nonfeedback amplifiers are relatively low-cost but have high power consumption and, more importantly, can hardly produce the  $1280 \times 1024$  resolution required for positive signal edges.

The Current-Feedback Amplifier OPA623 and the Dual Current Source OPA2662, two monolithic ICs manufactured on a complementary bipolar process, offer reasonably priced, effective alternatives. These new ICs differ both in performance and in manufacturing costs. They are not, however, limited to video output stage control. The problem of controlling an input or load resistance is a much more general dilemma present in a wide variety of applications. The real trick is to find amplifiers that can operate stably with complex loads, have low power consumption, and are capable of charging load capacitances with high currents in as little time as possible. In these categories as well, the OPA623 and OPA2662 prove themselves extremely viable options.

### DRIVER AMPLIFIER USING THE OPA623

The Wide-Band Current-Feedback Amplifier, OPA623, is available in 8-pin DIL and SO packages and delivers up to  $\pm 70\text{mA}$  output current at a supply voltage of  $\pm 5\text{V}$  and low quiescent current of  $4\text{mA}$ . Figure 9 shows the driver circuit using the OPA623. The OPA623 amplifies the video signal

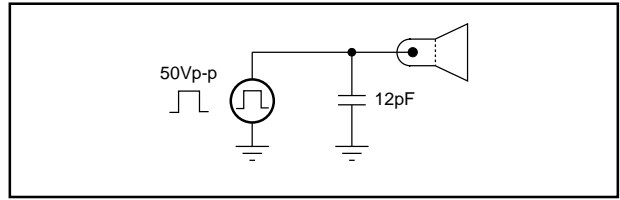

FIGURE 4. Cathode Voltage Control.

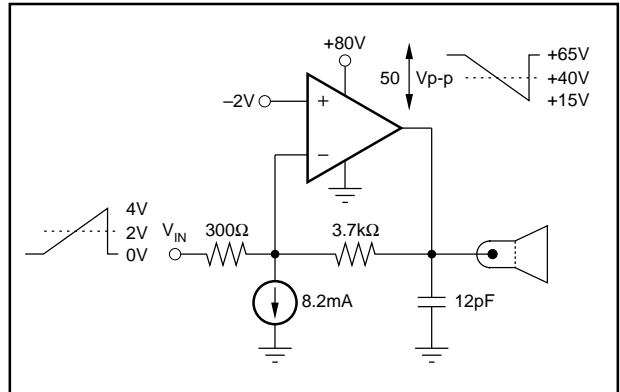

FIGURE 5. Basic Configuration of the Driver Circuit.

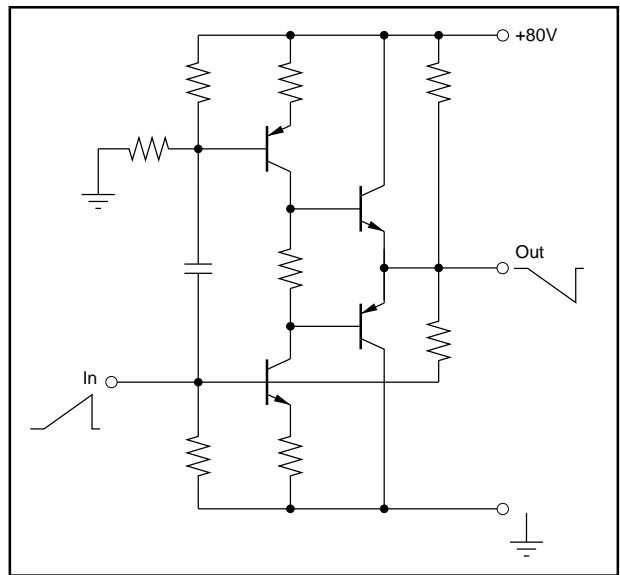

FIGURE 6. Internal Structure of the Video Output Stage CR3425.

from  $0.8\text{Vp}$  to  $4\text{Vp}$  and drives the complex input resistance of the CR3425 output stage. Figure 10 shows the pulse response at the OPA623 output, and Figure 11 that at the output of the video output stage. The rise and fall times of the OPA623 are  $1.85\text{ns}$  and  $1.95\text{ns}$ , respectively. Thus the OPA623 can drive complex loads of  $24\Omega + 287\Omega \parallel 50\text{pF}$  at an output voltage of  $4\text{Vp}$  and slew rate of about  $1700\text{V}/\mu\text{s}$  (ca.  $4\text{Vp} \cdot 0.8\text{ns}/1.9\text{ns}$ ). Using the OPA623, the output of the video output stage CR3425 can charge the  $12\text{pF}$  load capacitor with  $40\text{V}$  in  $3\text{ns}$  and discharge  $40\text{V}$  in  $2.3\text{ns}$ . In contrast

to direct control, control using the OPA623 results in an edge slope of 0.85ns for the rising edge and 0.15ns for the falling edge.

### DRIVER AMPLIFIER USING THE OPA2662

The second test used the Dual Diamond Transistor OPA2662 to drive the video output stage. This new wide-band IC contains two voltage-controlled current sources (transconductance amplifiers) in a 16-pin package. Each current source delivers or pulls up to  $\pm 75\text{mA}$  at its high-impedance collector. The voltage at the high-impedance

base appears in low-impedance form at the emitter and produces a current flow toward ground via the emitter resistor. This current is then reflected by a factor of 3 to the collector. As shown in Figure 12, it's easy to connect two current sources in parallel, which produces driving power of  $\pm 150\text{mA}$ . A compensation network connected to the emitters provides even more current during the charge phase. Figure 13 shows the excellent test results using this configuration. At the output of the CR3425, the design produces rise and fall times of 2.4ns and 2.15ns, respectively, with cathode voltage variation of 50Vp-p. This variation is the maxi-

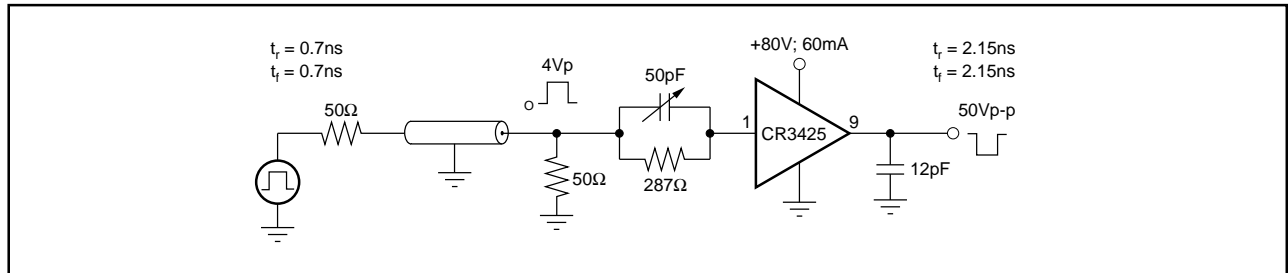

FIGURE 7. Driver Circuit Using a Pulse Generator.

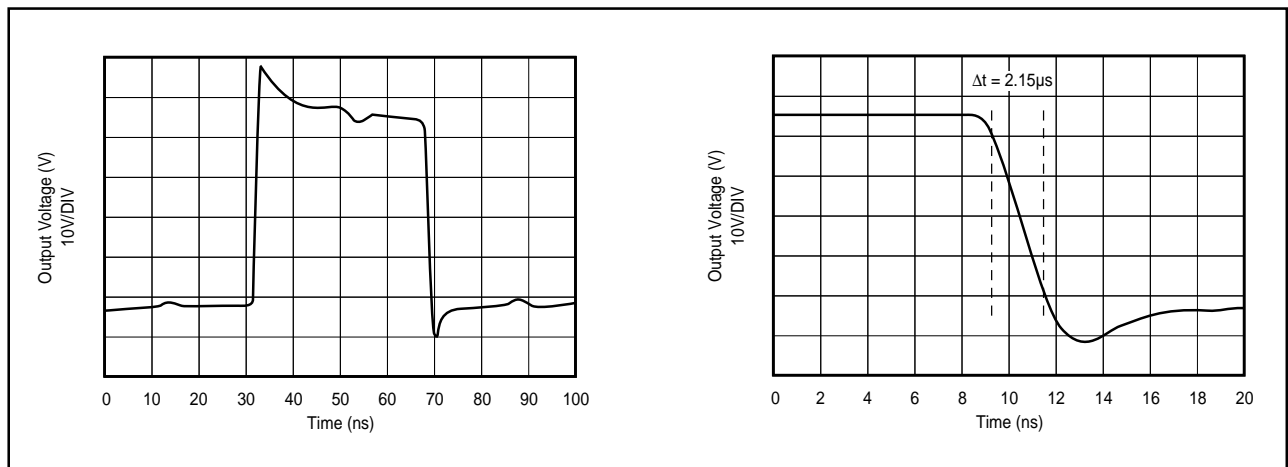

FIGURE 8. Test Circuit Response.

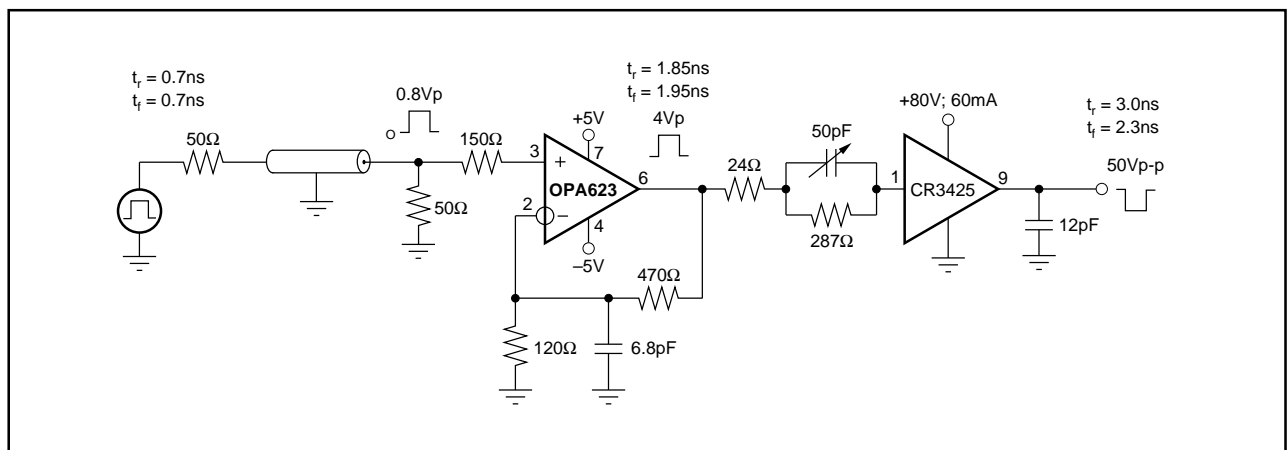

FIGURE 9. Driver Circuit Using the OPA623.

imum possible cathode modulation, during which most picture tubes are already in overdrive. Reducing the maximum output voltage lowers the rise and fall times to less than 2ns, making it possible to process video pulses of 6ns. The shorter the pulse, the more important it is to achieve sufficient cathode voltage, since high resolutions are accompanied by high horizontal deflection frequencies so that the turnaround time of the electron ray at the phosphor point becomes shorter and shorter. The rise time of a phosphor point is the time until it converts to the electron charge into a visible light (R, G, or B).

In comparison to direct control of the output stage by a generator, when controlled by the OPA2662, the rising edge has a small additional edge slope of 0.25ns and the falling edge is driven exactly as fast as with direct control. Considering that most signal generators are quite expensive, this comparison speaks quite well for the OPA2662.

### CONCLUSION

Only in the last few years has it become possible to use integrated amplifiers in video signal processing with high-resolution monitors. New developments in circuit technology and IC manufacturing processes, as well as the rapidly increasing demand for low-cost displays, have combined to accelerate advances in video design. Today, integrated RGB video amplifiers are already available with a bandwidth of 100MHz. In addition to amplification and contrast control, these amplifiers offer additional functions such as clamping, blanking, and sync separation, and they can also drive the output stage.

Both driver circuit configurations shown here allow video output stage control that is less integrated but also more powerful, and the configurations achieve a level of performance previously possible only with complex, large, and

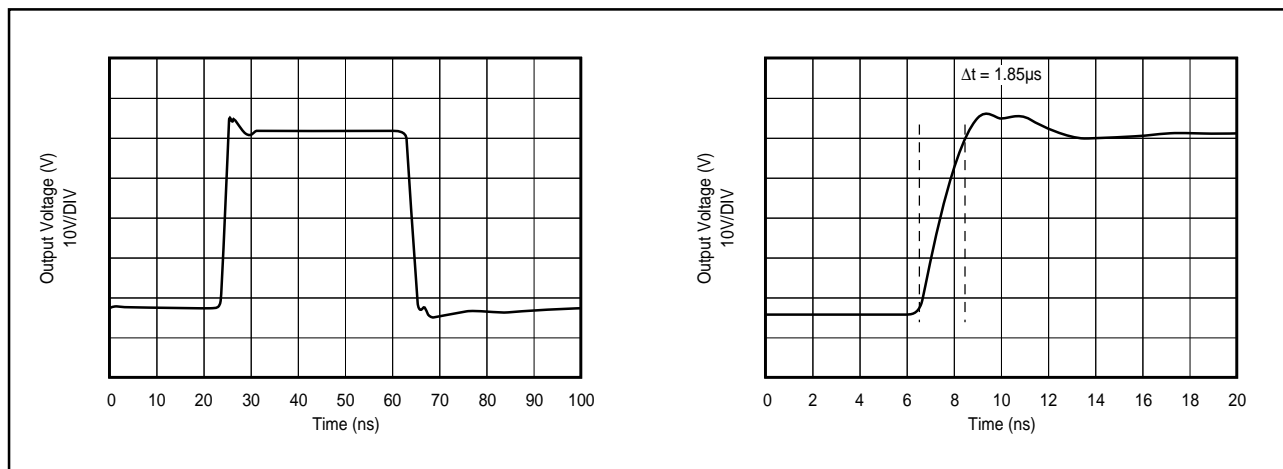

FIGURE 10. OPA623 Output.

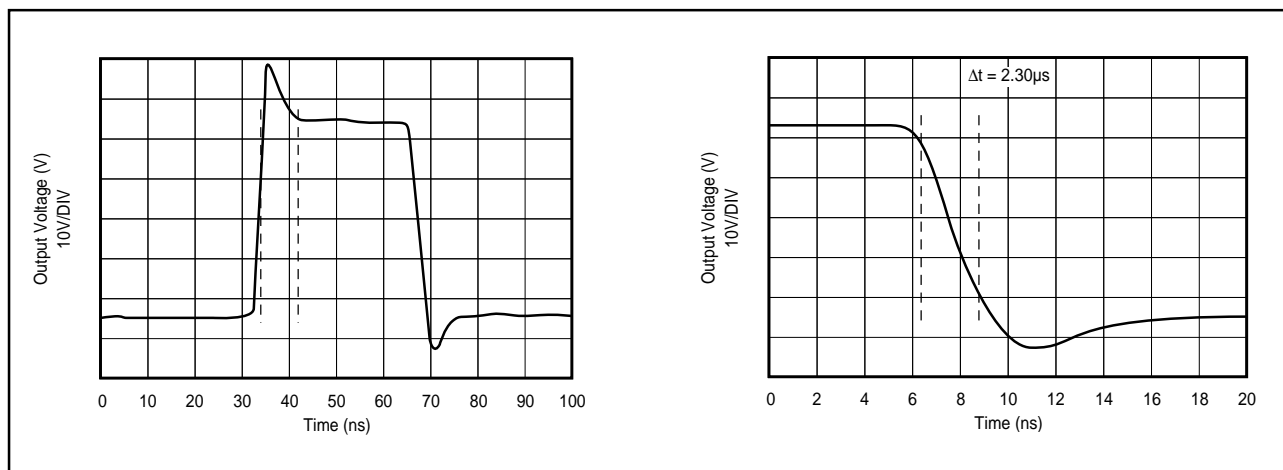

FIGURE 11. Response of the Test Circuit Shown in Figure 6.

expensive hybrid circuits. The lower cost, smaller driver circuit using the OPA623 can be used for 1600 x 1280 resolutions, while the OPA2662 can be used for applications requiring resolutions of up to 2k x 2k. It should be noted, however, that at 2k x 2k both the driver circuit and the video output stage operate at their performance limit. At frequencies over 100MHz, separation of the three color channels in different video amplifiers is the only effective way to keep the crosstalk between the channels to less than 30dB. Finally, a comparison of the two driver circuits demonstrates the superiority of a high-impedance current source over a low-impedance voltage source when controlling low-impedance, capacitive loads. Although the OPA623 with 350MHz appears at first glance a better choice than the OPA2662 with 200MHz, the current-source output and higher drive capability of the OPA2662 give it an edge in practice.

The next step will be to assemble both the monolithic integrated driver amplifier and the hybrid video output stage on the same substrate.

Both driver circuits are available from Burr-Brown as assembled demo boards so that you can test the configurations for yourself.

### REFERENCES

OPA623 Product Data Sheet  
Burr-Brown

OPA2662 Product Data Sheet  
Burr-Brown

CR3425 Product Data Sheet  
Philips

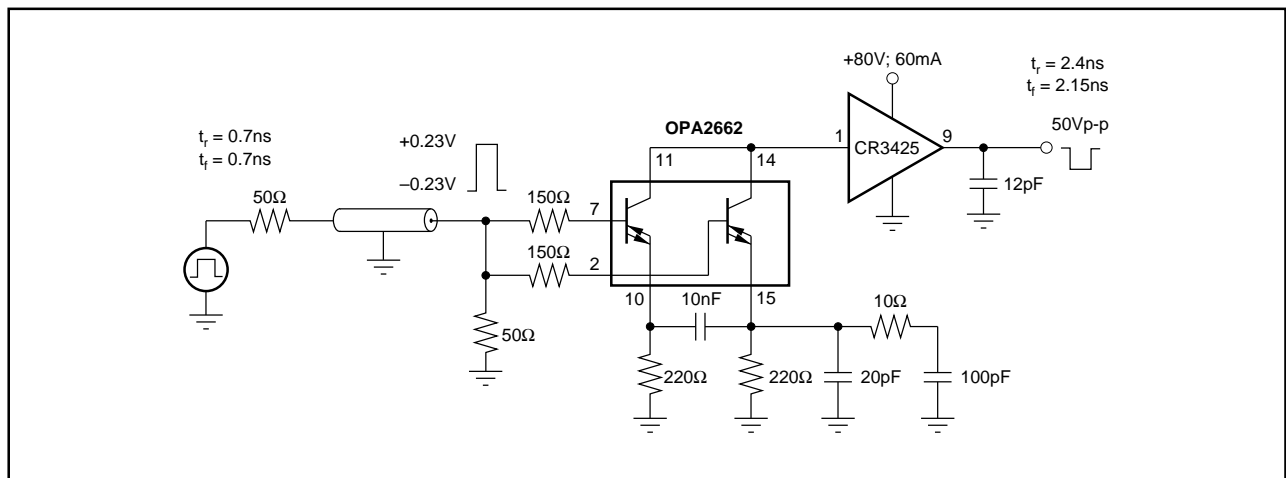

FIGURE 12. Driver Circuit Using the OPA2662.

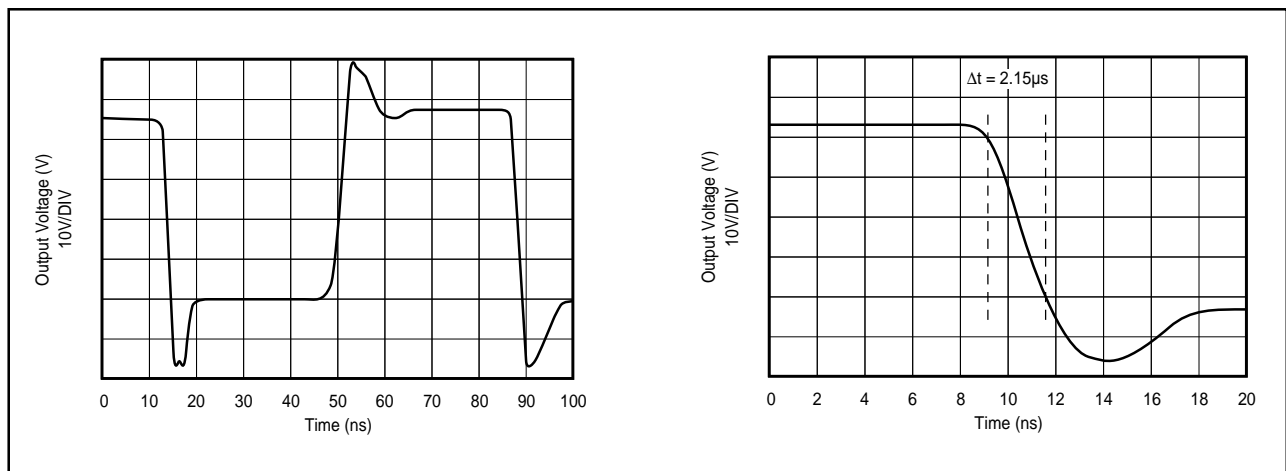

FIGURE 13. Test Circuit Response Curves.

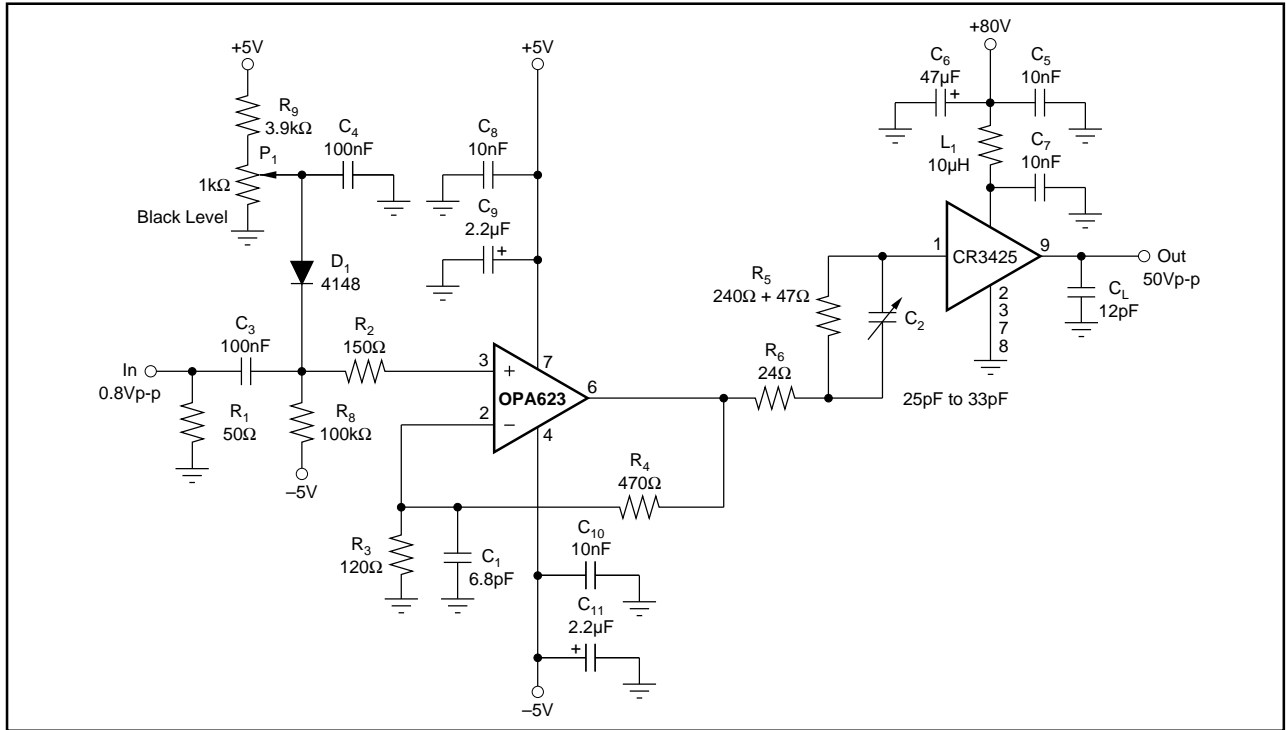

FIGURE 14. Driver Circuit 1.

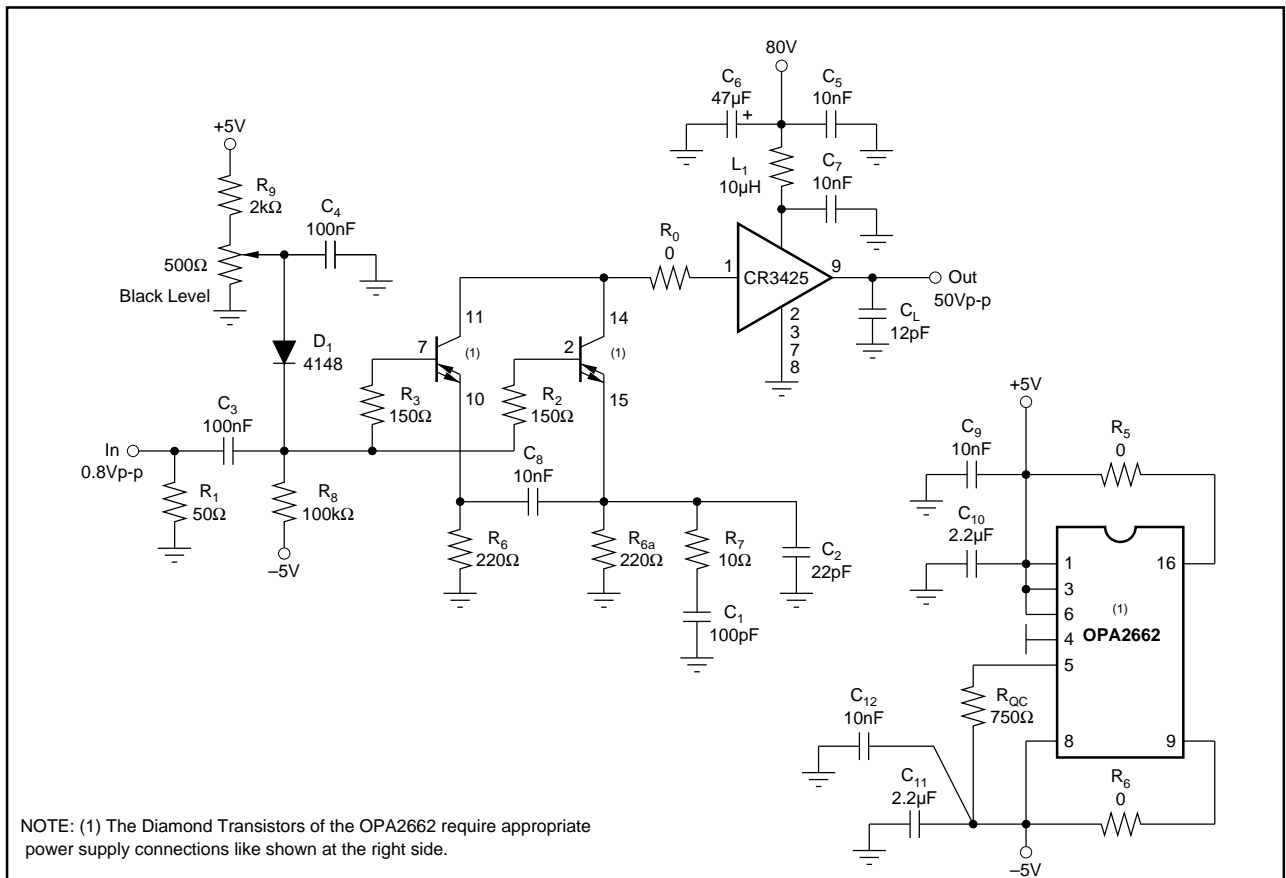

FIGURE 15. Driver Circuit 2.

## **IMPORTANT NOTICE**

Texas Instruments and its subsidiaries (TI) reserve the right to make changes to their products or to discontinue any product or service without notice, and advise customers to obtain the latest version of relevant information to verify, before placing orders, that information being relied on is current and complete. All products are sold subject to the terms and conditions of sale supplied at the time of order acknowledgment, including those pertaining to warranty, patent infringement, and limitation of liability.

TI warrants performance of its semiconductor products to the specifications applicable at the time of sale in accordance with TI's standard warranty. Testing and other quality control techniques are utilized to the extent TI deems necessary to support this warranty. Specific testing of all parameters of each device is not necessarily performed, except those mandated by government requirements.

Customers are responsible for their applications using TI components.

In order to minimize risks associated with the customer's applications, adequate design and operating safeguards must be provided by the customer to minimize inherent or procedural hazards.

TI assumes no liability for applications assistance or customer product design. TI does not warrant or represent that any license, either express or implied, is granted under any patent right, copyright, mask work right, or other intellectual property right of TI covering or relating to any combination, machine, or process in which such semiconductor products or services might be or are used. TI's publication of information regarding any third party's products or services does not constitute TI's approval, warranty or endorsement thereof.