

# High-side current-sensing circuit design with MSP430™ smart analog combo

## Design Goals

Input		Output		Supply	
$I_{iMin}$	$I_{iMax}$	$V_{oMin}$	$V_{oMax}$	$V_{cc}$	$V_{ee}$
25 mA	300 mA	0.25 V	3 V	3.3 V	0 V

## Design Description

Some MSP430™ microcontrollers (MCUs) contain configurable integrated signal chain elements such as op-amps, DACs, and programmable gain stages. These elements make up a peripheral called the smart analog combo (SAC). For information on the different types of SACs and how to leverage their configurable analog signal chain capabilities, visit [MSP430 MCUs Smart Analog Combo Training](#). To get started with your design, download the [High-Side Current Sensing Circuit Design Files](#).

This single-supply, high-side, low-cost current sensing solution detects load current between 25 mA and 300 mA and converts it to an output voltage from 0.25 V to 3 V. High-side sensing allows for the system to identify ground shorts and does not create a ground disturbance on the load. The circuit uses the [MSP430FR2311](#) SAC\_L1 op-amp in general-purpose (GP) mode with OAx+ and OAx- dedicated as noninverting and inverting inputs. The same approach can be implemented with the [MSP430FR2355](#), featuring four SAC\_L3 peripherals with additional built-in DAC and PGA capabilities. The output of the integrated SAC op-amp can be sampled directly by the on-board ADC or monitored by the on-board comparator for further processing inside the MCU.

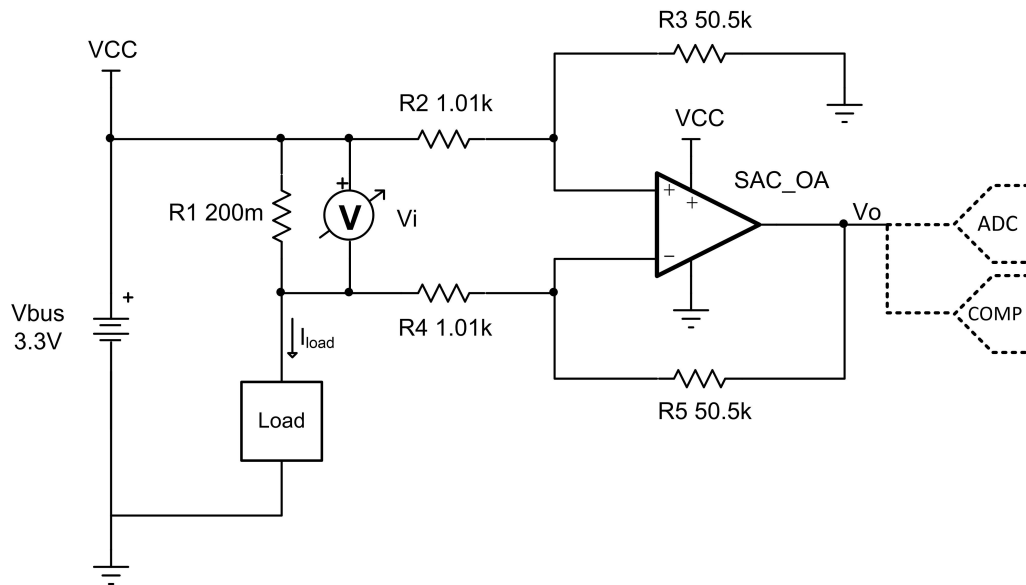

## Design Notes

- DC common-mode rejection ratio (CMRR) performance is dependent on the matching of the gain setting resistors,  $R_2$ - $R_5$ .
- Increasing the shunt resistor increases power dissipation.
- Ensure that the common-mode voltage is within the linear input operating region of the amplifier. The common-mode voltage is set by the resistor divider formed by  $R_2$ ,  $R_3$ , and the bus voltage. Depending on the common-mode voltage determined by the resistor divider a rail-to-rail input (RRI) amplifier may not be required for this application.
- An op amp that does not have a common-mode voltage range that extends to  $V_{cc}$  may be used in low-gain or an attenuating configuration.
- A capacitor placed in parallel with the feedback resistor will limit bandwidth, improve stability, and help reduce noise.
- Use the op amp in a linear output operating region. Linear output swing is usually specified under the  $A_{OL}$  test conditions.
- If the solution is implemented with the MSP430FR2311 SAC\_L1 or with the MSP430FR2355 SAC\_L3, the op-amp is configured in general-purpose mode.
- If the solution is implemented using the MSP430FR2311 TIA, the input voltage range is limited to  $V_{CC}/2$ , so the gain or range must be adjusted accordingly.
- The [High-Side Current Sensing Circuit Design Files](#) include code examples showing how to properly initialize the SAC peripherals.

## Design Steps

1. The full transfer function of the circuit is provided below.

$$V_o = I_{in} \times R_1 \times \frac{R_5}{R_4}$$

Given  $R_2 = R_4$  and  $R_3 = R_5$

2. Calculate the maximum shunt resistance. Set the maximum voltage across the shunt to 60 mV.

$$R_1 = \frac{V_{I_{Max}}}{I_{I_{Max}}} = \frac{60\text{mV}}{300\text{mA}} = 200\text{m}\Omega$$

3. Calculate the gain to set the maximum output swing range.

$$\text{Gain} = \frac{V_{oMax} - V_{oMin}}{(I_{I_{Max}} - I_{I_{Min}}) \times R_1} = \frac{3\text{V} - 0.25\text{V}}{(0.3\text{A} - 0.025\text{A}) \times 200\text{m}\Omega} = 50\frac{\text{V}}{\text{V}}$$

4. Calculate the gain setting resistors to set the gain calculated in step 3.

$$\text{Choose } R_2 = R_4 = 1.01\text{k}\Omega \text{ (Standard value)}$$

$$R_3 = R_5 = R_2 \times \text{Gain} = 1.01\text{k}\Omega \times 50\frac{\text{V}}{\text{V}} = 50.5\text{k}\Omega \text{ (Standard value)}$$

5. Calculate the common-mode voltage of the amplifier to ensure linear operation.

$$V_{cm} = V_{CC} \times \frac{R_3}{R_2 + R_3} = 3.3\text{V} \times \frac{50.5\text{k}}{1.01\text{k} + 50.5\text{k}} = 3.235\text{V}$$

6. The upper cutoff frequency ( $f_H$ ) is set by the non-inverting gain (noise gain) of the circuit and the gain bandwidth (GBW) of the op amp.

$$f_H = \frac{\text{GBW}}{\text{Noise Gain}} = \frac{4\text{MHz}}{51\frac{\text{V}}{\text{V}}} = 78.43 \text{ kHz}$$

**Design Simulations**

**DC Simulation Results**

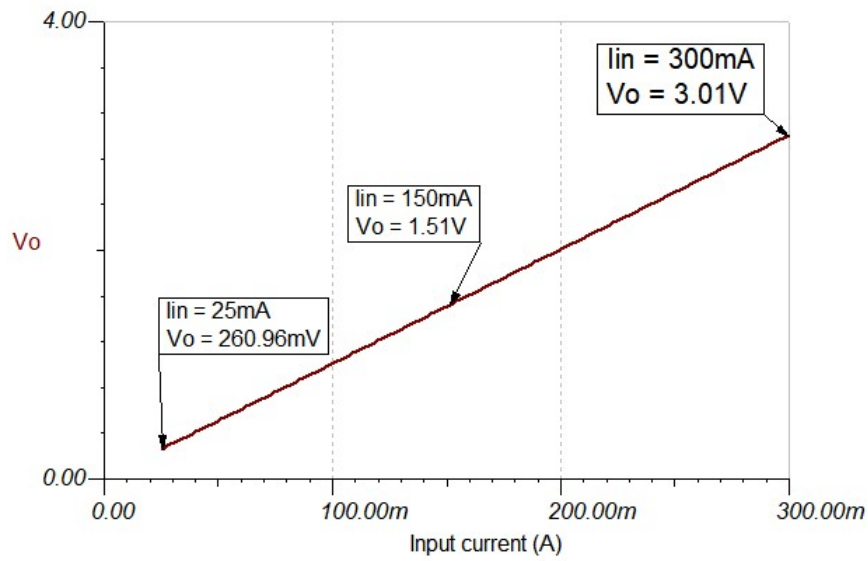

**AC Simulation Results**

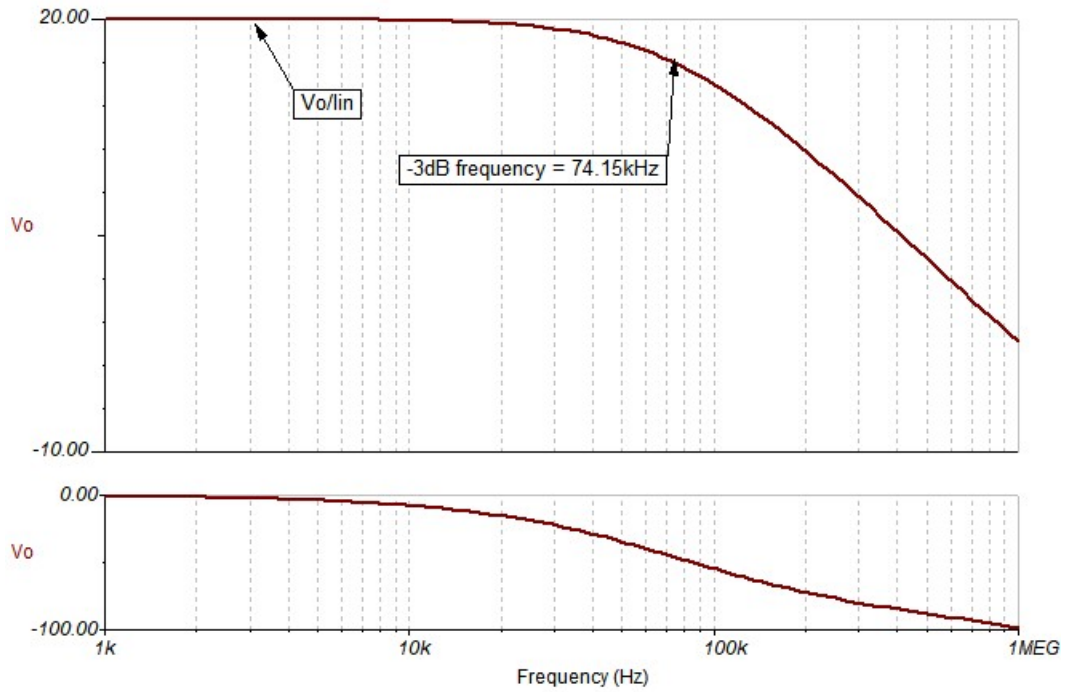

### Target Applications

- Cordless power tool battery pack
- E-bike, e-scooter battery pack
- Motor drives
- LED luminaire
- Grid infrastructure

### References

1. [High-Side Current Sensing Circuit Design Files](#)
2. [Analog Engineer's Circuit Cookbooks](#)
3. [MSP430FR2311 TINA-TI Spice Model](#)
4. [MSP430 MCUs Smart Analog Combo Training](#)





### Design Featured Op Amp

MSP430FRxx Smart Analog Combo		
	MSP430FR2311 SAC_L1	MSP430FR2355 SAC_L3
$V_{CC}$	2.0 V to 3.6 V	
$V_{CM}$	-0.1 V to $V_{CC} + 0.1$ V	
$V_{out}$	Rail-to-rail	
$V_{os}$	$\pm 5$ mV	
$A_{OL}$	100 dB	
$I_q$	350 $\mu$ A (high-speed mode)	
	120 $\mu$ A (low-power mode)	
$I_b$	50 pA	
UGBW	4 MHz (high-speed mode)	2.8 MHz (high-speed mode)
	1.4 MHz (low-power mode)	1 MHz (low-power mode)
SR	3 V/ $\mu$ s (high-speed mode)	
	1 V/ $\mu$ s (low-power mode)	
Number of channels	1	4
<a href="http://www.ti.com/product/MSP430FR2311">http://www.ti.com/product/MSP430FR2311</a>		
<a href="http://www.ti.com/product/MSP430FR2355">http://www.ti.com/product/MSP430FR2355</a>		

### Design Alternate Op Amp

MSP430FR2311 Transimpedance Amplifier	
$V_{CC}$	2.0 V to 3.6 V
$V_{CM}$	-0.1 V to $V_{CC}/2$ V
$V_{out}$	Rail-to-rail
$V_{os}$	$\pm 5$ mV
$A_{OL}$	100 dB
$I_q$	350 $\mu$ A (high-speed mode)
	120 $\mu$ A (low-power mode)
$I_b$	5 pA (TSSOP-16 with OA-dedicated pin input)
	50 pA (TSSOP-20 and VQFN-16)
UGBW	5 MHz (high-speed mode)
	1.8 MHz (low-power mode)
SR	4 V/ $\mu$ s (high-speed mode)
	1 V/ $\mu$ s (low-power mode)
Number of channels	1
<a href="http://www.ti.com/product/MSP430FR2311">http://www.ti.com/product/MSP430FR2311</a>	

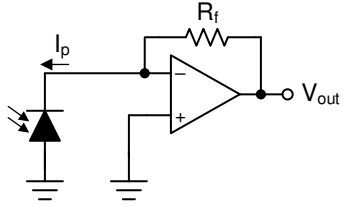
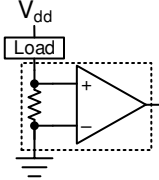
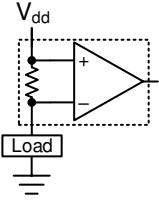
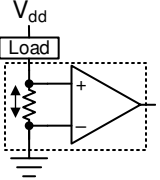
**Related MSP430 Circuits**

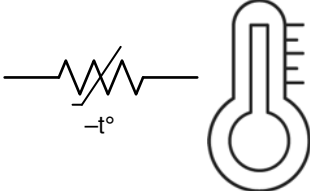
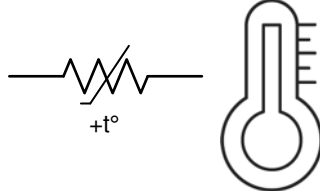
<p>Low-noise and long-range PIR sensor conditioner circuit</p> 	<p>Bridge amplifier circuit</p> 	<p>Transimpedance amplifier circuit</p> 
<p>Single-supply, low-side, unidirectional current-sensing circuit</p> 	<p>High-side current sensing with discrete difference amplifier circuit</p> 	<p>Low-side, bidirectional current-sensing circuit</p> 
<p>Half-wave rectifier circuit</p> 	<p>Temperature sensing with NTC thermistor circuit</p> 	<p>Temperature sensing with PTC thermistor circuit</p> 

---

## Revision History

NOTE: Page numbers for previous revisions may differ from page numbers in the current version.

Changes from November 26, 2019 to March 6, 2020	Page
• Added <i>Related MSP430 Circuits</i> section.....	5

---

## IMPORTANT NOTICE AND DISCLAIMER

TI PROVIDES TECHNICAL AND RELIABILITY DATA (INCLUDING DATA SHEETS), DESIGN RESOURCES (INCLUDING REFERENCE DESIGNS), APPLICATION OR OTHER DESIGN ADVICE, WEB TOOLS, SAFETY INFORMATION, AND OTHER RESOURCES "AS IS" AND WITH ALL FAULTS, AND DISCLAIMS ALL WARRANTIES, EXPRESS AND IMPLIED, INCLUDING WITHOUT LIMITATION ANY IMPLIED WARRANTIES OF MERCHANTABILITY, FITNESS FOR A PARTICULAR PURPOSE OR NON-INFRINGEMENT OF THIRD PARTY INTELLECTUAL PROPERTY RIGHTS.

These resources are intended for skilled developers designing with TI products. You are solely responsible for (1) selecting the appropriate TI products for your application, (2) designing, validating and testing your application, and (3) ensuring your application meets applicable standards, and any other safety, security, regulatory or other requirements.

These resources are subject to change without notice. TI grants you permission to use these resources only for development of an application that uses the TI products described in the resource. Other reproduction and display of these resources is prohibited. No license is granted to any other TI intellectual property right or to any third party intellectual property right. TI disclaims responsibility for, and you will fully indemnify TI and its representatives against, any claims, damages, costs, losses, and liabilities arising out of your use of these resources.

TI's products are provided subject to [TI's Terms of Sale](#) or other applicable terms available either on [ti.com](http://ti.com) or provided in conjunction with such TI products. TI's provision of these resources does not expand or otherwise alter TI's applicable warranties or warranty disclaimers for TI products.

TI objects to and rejects any additional or different terms you may have proposed.

Mailing Address: Texas Instruments, Post Office Box 655303, Dallas, Texas 75265  
Copyright © 2022, Texas Instruments Incorporated