

Audio Power Amplifier Solutions for New Wireless Phones

as Presented at the Wireless Symposium/Portable by Design Conference, February 2000

Michael Score and Donald Dapkus

Audio Power Amplifier Products

ABSTRACT

Wireless phones continue to gain additional features, making them more valuable to the end user. Many of these features involve increased audio functionality, and hence, some additional design effort on the audio portion of the phone. This paper gives an overview of audio amplifiers before describing different audio architectures that can be used to implement features like ear-bud speakers, stereo headphone drive, hands-free mode, and other emerging needs. Some common audio pitfalls and their solutions are presented. The paper will also discuss wireless market trends and how they affect the audio system.

Contents

1	Introduction	2
2	Audio Power Amplifier Key Care Abouts in Wireless Phones	2
2.1	Single-Ended vs Differential Input	2
2.2	Turn-On/Off Pop	3
2.3	Single-Ended vs Bridge-Tied Load	4
2.4	Power Dissipated in the Audio Power Amplifier	5
2.5	Class-AB versus Class-D	6
3	Overall System Block Diagrams	13
3.1	Ear-Bud Speaker	14
3.2	Ear-Bud Speaker with Hands-Free or Walkie-Talkie Mode	14
3.3	Mono Internal Speaker, Stereo Headphones	15
3.4	Cost-Driven Car Kit	17
3.5	Feature-Driven Car Kit	17
4	Wireless Market Trends	18
4.1	Supply Voltages	18
4.2	Volume Control	18
4.3	Packaging	19
5	Conclusion	20

List of Figures

1	Output Waveforms of Possible Pop Situations	3
2	Bridge-Tied Load Configuration	4
3	Single-Ended Configuration and Frequency Response	5
4	Power Dissipated vs Output Power	6
5	Peak and Average Power of Music and Tones versus Time	7

6	Maximum Ambient Temperature of a MSOP PowerPAD vs Flip Chip at 3.3 V	8
7	Maximum Ambient Temperature of a MSOP PowerPAD vs Flip Chip at 5 V	8
8	Maximum Ambient Temperature of Class-D vs Class-AB	10
9	Common Class-D Modulation Scheme	11
10	Class-D LC Low-Pass Output Filter	11
11	New Modulation Scheme	12
12	Ear-Bud and Internal Speaker	13
13	Ear-Bud and 2-W Internal Speaker	14
14	700-mW Mono Internal Speaker and Stereo Headphones	15
15	2-W Mono Internal Speaker and Stereo Headphones	16
16	Low-Cost 2-W Car Kit	17
17	Feature-Rich 11-W Car Kit	18
18	PowerPAD Layout for a 4-Layer	19

1 Introduction

For many years, audio amplifier ICs were basically standard operational amplifiers that had been optimized to drive low impedance loads using a class-AB output stage configuration. As systems become more complex, more and more features are being integrated into the audio amplifiers, and different architectures are being used to optimize the amplifier for audio performance, efficiency, noise immunity, volume control, et cetera. Selecting the appropriate audio power amplifier is critical to making the most of the end product being designed.

2 Audio Power Amplifier Key Care Abouts in Wireless Phones

2.1 Single-Ended vs Differential Input

Amplifiers have two possible input configurations: single-ended and differential. Differential inputs enable cancellation of any noise common on both inputs. Noise generated at the input of the amplifier has a greater effect than noise generated at the output, because any noise on the input is multiplied by the gain of the amplifier. The inputs to the amplifier are especially sensitive to noise because they are typically not driven by a very low impedance source. Noise immunity is very important in wireless phones because the RF signal is sent in bursts such that the frequency between bursts is in the audio band. RF rectification is such a problem that many manufacturers shield the audio portion of the phone.

To confirm that differential inputs have higher immunity to RF noise, two evaluation modules (EVMs) were placed side by side. One of the EVMs was the TPA701, which has differential inputs. The other EVM was the TPA711, which has single-ended inputs. Both devices were connected to a speaker and turned on. Then, an activated wireless phone was placed over each device. The phone was moved up and down and rotated to find the maximum signal, and in all cases, the TPA701 with differential inputs had much less noise caused by the RF rectification of the phone's transmission signal.

The disadvantage of having a differential input device is that it requires an additional pin, which usually means a larger package in a very space critical application. The routing of an extra signal line also requires extra board space, but in most cases it is desirable because less shielding will be required.

When using an amplifier with differential inputs, there are techniques to ensure that the device is configured correctly. If the source driving the amplifier is differential, it is very important to keep the differential traces the same length and close together to cancel any common mode noise induced in the trace. If using a single-ended source into a differential amplifier, ground one amplifier input through a capacitor near the source of the other input. Grounding the capacitor near the source enables common-mode noise cancellation.

2.2 Turn-On/Off Pop

Pop is the noise that speakers make when an amplifier is turned off, turned on, placed in, or taken out of shutdown. Pop occurs when there is a change in voltage across speaker. Pop is very dependent on rise and fall times and pulse width. If the pulse width is less than $50\ \mu\text{s}$, which is higher frequency than the ear can hear, and faster than a speaker can respond, no pop is made. This, however, requires the voltage to only spike very quickly and come back to the same potential, which is not typically useful in an audio amplifier. At power up, the output is required to transition from ground to one-half the supply rail. One possible solution would be to make the outputs ramp faster than the ear can hear; however, the speaker cannot respond that quickly and it will change potential within the audio frequency, which results in a large pop. One way to change potential with minimal pop is to ramp the voltage very slowly. If the ramp is slower than $50\ \text{ms}$, the ear cannot hear it. Figure 1 shows pulses and explains if they will be audible or inaudible.

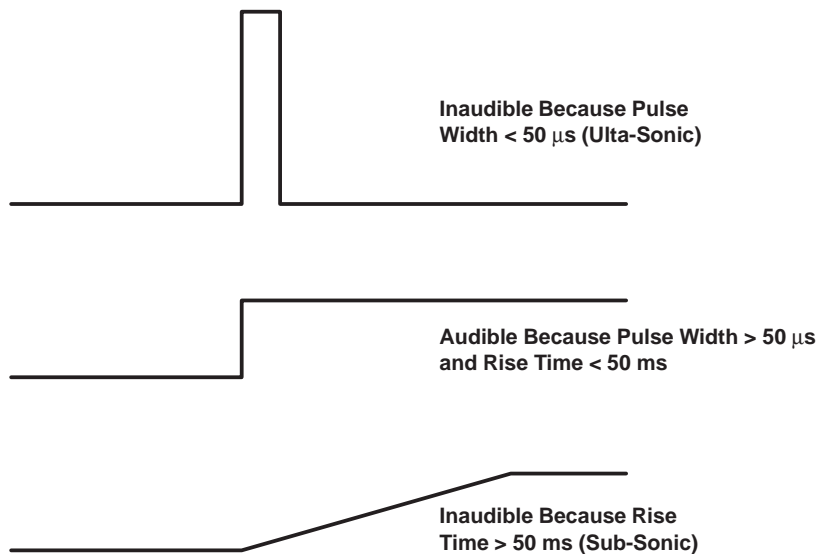

Figure 1. Output Waveforms of Possible Pop Situations

Pop is primarily a factor in single-supply amplifiers because the outputs are centered around an internally generated mid-rail voltage. When the mid-rail voltage rises or falls quickly at turn on or turn off there is a pop. One method of limiting the pop is to make the mid-rail voltage rise and fall slowly (subsonically). This is accomplished by using a capacitor connected from the bypass pin to ground, which forms an RC time constant with the high impedance resistor-divider network from V_{DD} to ground used to generate the mid-rail voltage. For BTL amplifiers, minimize pop by ensuring that the outputs rise and fall together. While this can be done in bridge-tied load applications, it is very difficult with a single-ended applications because only one side of the speaker is changing. Another difficulty with pop in single-ended output applications is that there is a coupling capacitor at the output that holds charge. The coupling will not change its voltage instantly, so if the output of the amplifier changes voltage, that voltage plus the voltage across the capacitor is placed across the speaker.

2.3 Single-Ended vs Bridge-Tied Load

Wireless phones use single-ended (SE) and bridge-tied load (BTL) audio amplifiers depending on application. Figure 2 shows a class-AB audio power amplifier in a bridge-tied load configuration. There are several potential benefits to this differential drive configuration, but initially consider power to the load. The differential drive to the speaker means that as one side is slewing up, the other side is slewing down, and vice versa. This, in effect, doubles the voltage swing on the load as compared to a single-ended load. Plugging twice the output voltage into the power equation, where voltage is squared, yields 4 times the output power from the same supply rail and load impedance (see equation 1).

$$P = \frac{V^2}{R_L} \quad (1)$$

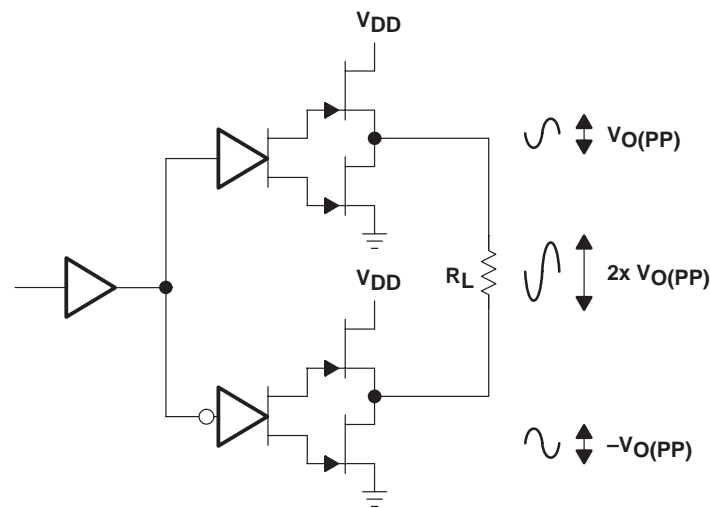

Figure 2. Bridge-Tied Load Configuration

In an amplifier operating at 3.3 V, using a BTL configuration raises the power into an 8- Ω speaker to 300 mW from a single-ended limit of 75 mW.

In addition to increased power there are frequency response and system size advantages to bridge-tied load amplifiers. Consider the single-supply SE configuration shown in Figure 3. A coupling capacitor is required to block the dc offset voltage from reaching the load. These capacitors can be quite large (approximately 33 μF to 1000 μF) so they tend to be expensive, heavy, and occupy valuable PCB area. The frequency limiting effect is due to the high pass filter network created with the speaker impedance and the coupling capacitance. This cut-off frequency is calculated with equation 2. Equation 3 can be used for sizing the coupling capacitor for a desired cut-off frequency in a single-ended application.

$$F_c = \frac{1}{2 \times R_L \times C_C} \quad (2)$$

$$C_C = \frac{1}{2 \times R_L \times f_c} \quad (3)$$

For example, a 68- μF capacitor with an 8- Ω speaker would attenuate low frequencies below 293 Hz. The BTL configuration cancels the dc offsets, which eliminates the need for the blocking capacitors. Low-frequency performance is then limited only by the input network and speaker response. Cost and PCB space are also minimized by eliminating the bulky coupling capacitor.

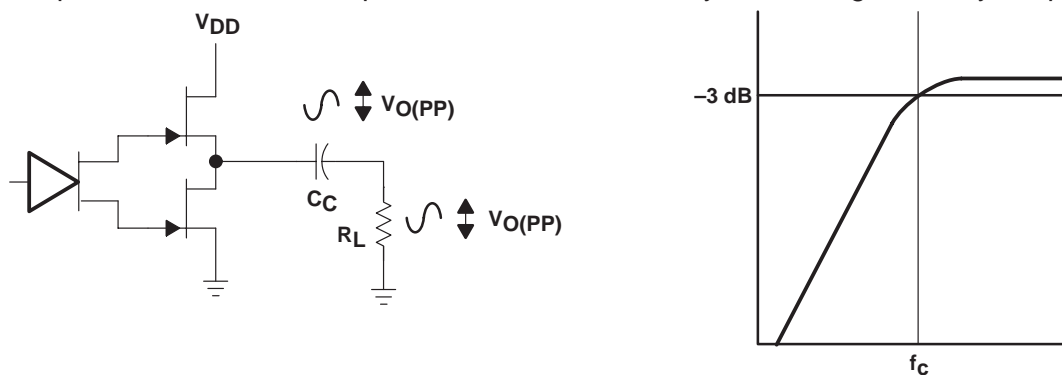

Figure 3. Single-Ended Configuration and Frequency Response

Increasing power to the load does carry a penalty of increased internal power dissipation. The increased dissipation is understandable considering that the BTL configuration produces four times the output power of the SE configuration.

2.4 Power Dissipated in the Audio Power Amplifier

Heat is a very important in wireless phones. Increasing computing power in the phone results in more power dissipated in the DSP/microprocessor. Decreasing phone size means less volume for heat to dissipate and puts more constraints on getting heat out of the phone.

The power dissipated in a class-AB amplifier is calculated below: where P_D is the power dissipated in the amplifier, P_{SUP} is the power from the supply, P_L is the power to the load, V_{DD} is the supply voltage, I_L is the current to the load, and R_L is the load resistance.

$$P_D = P_{SUP} - P_L \quad (4)$$

In a class-AB amplifier, the output current equals the supply current, resulting in equation 5.

$$P_D = I_L(V_{DD} - I_L R_L) \quad (5)$$

Most amplifiers reach their maximum power dissipation within the operating range of the amplifier, which means as you drive the amplifier into clipping the device actually cools down. This can be seen in Figure 4 where the worst-case power dissipation occurs at about 0.22 watts for a 0.45 watt amplifier. The power dissipated in a linear amplifier is dissipated in the output transistors. As the output current increases from zero, the increase in current causes more power to be dissipated in the output transistors. After the power dissipation peaks, further increases in current causes a greater decrease in the voltage across the output transistor. This reduces power dissipation.

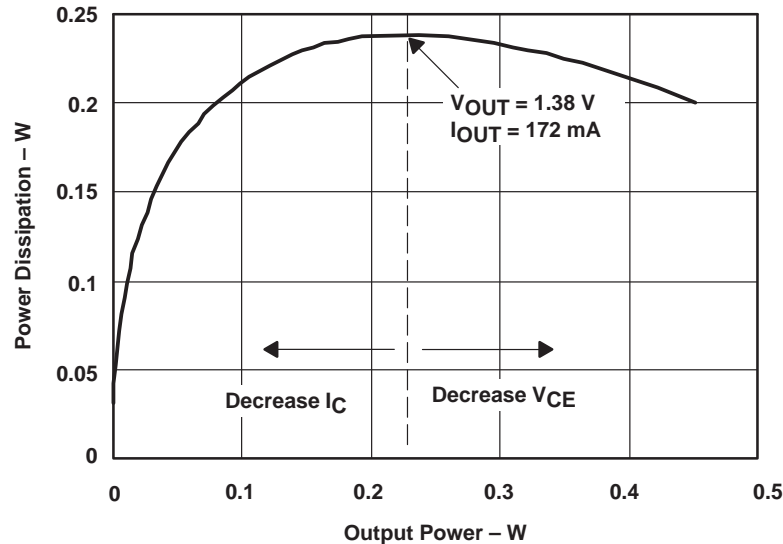

Figure 4. Power Dissipated vs Output Power

The equation for the maximum power dissipated is shown in equation 6.

$$P_{D(MAX)} = \frac{2 V_{DD}^2}{\pi^2 R_L} \quad (6)$$

The maximum ambient temperature depends on power dissipated, the heatsinking ability of the package, and the maximum junction temperature of the device. The derating factor or thermal impedance of a package is typically given in the audio power amplifier's data sheet. A package derating factor can easily be converted to the package thermal impedance (Θ_{JA}) using equation 7.

$$\Theta_{JA} = \frac{1}{\text{Derating Factor}} \quad (7)$$

To calculate maximum ambient temperatures, first consider the maximum power dissipated. Given the thermal impedance, the maximum allowable junction temperature ($T_{J(MAX)}$), and the power dissipation, the maximum ambient temperature ($T_{A(MAX)}$) can be calculated with the following equation.

$$T_{A(MAX)} = T_{J(MAX)} - \Theta_{JA} P_D \quad (8)$$

Understanding crest factor is the first step in determining the normal operating power of an amplifier. Unlike a sine wave, which is used in efficiency specifications, audio is a signal that has varying amplitude. Crest factor, the ratio of peak power to average in decibels (dB) as shown in equation 6, is an excellent means of calculating average power from peak power of different waveforms.

$$\text{Crest Factor} = 10 \log \left(\frac{P_{PEAK}}{P_{AV}} \right) \quad (9)$$

Music has much lower average power than a sine wave with equal peak power. Thus, music has a much higher crest factor than a sine wave. Figure 5 compares the average power of a music signal to a sine wave with both waveforms having the same peak power.

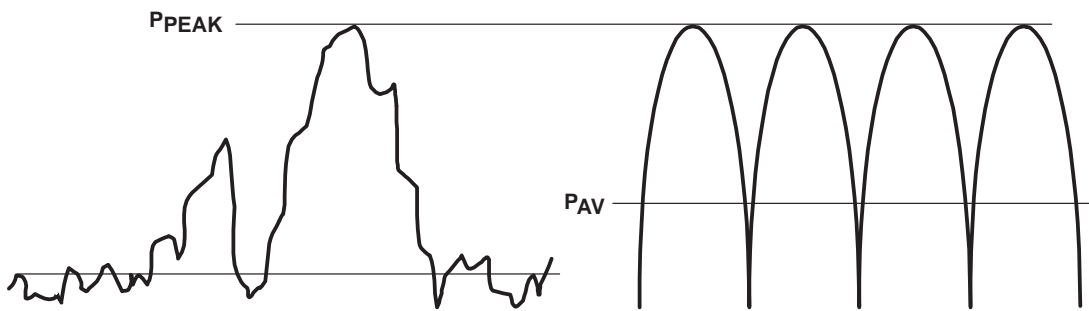

Figure 5. Peak and Average Power of Music and Tones versus Time

Music has a crest factor ranging from 12 to 22 dB with an average of around 15 dB, where a sine wave has a 3 dB crest factor. This means that given an amplifier that can output 4 watts peak, it can output 2 watts of average power for a sine wave, but will only output an average of 125 milliwatts of music without clipping the output music waveform.

It is very important to understand how an amplifier will work in a system to ensure that the device will not overheat. Various packages have different thermal impedances. Figure 6 compares the maximum ambient temperatures for the MSOP PowerPAD™ package to a standard 8-pin flip-chip. The MSOP PowerPAD has a thermal impedance of 58.5 °C/W, and the flip-chip has a thermal impedance of 150 °C/W. The die temperature of the MSOP PowerPAD does not get as high as for the flip-chip. It is not as crucial to check temperatures with a 3.3 V system, but if the supply is 5 V, the flip-chip becomes questionable as to how well it will run at elevated ambient temperatures. This is shown in Figure 7.

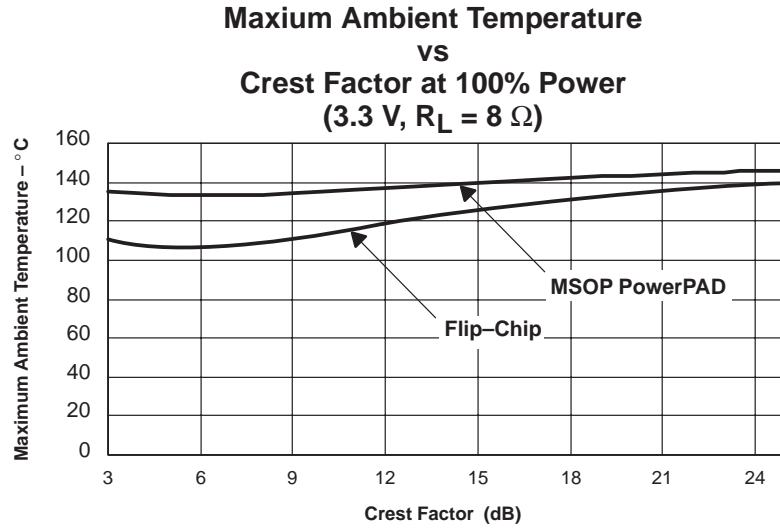

Figure 6. Maximum Ambient Temperature of a MSOP PowerPAD vs Flip Chip at 3.3 V

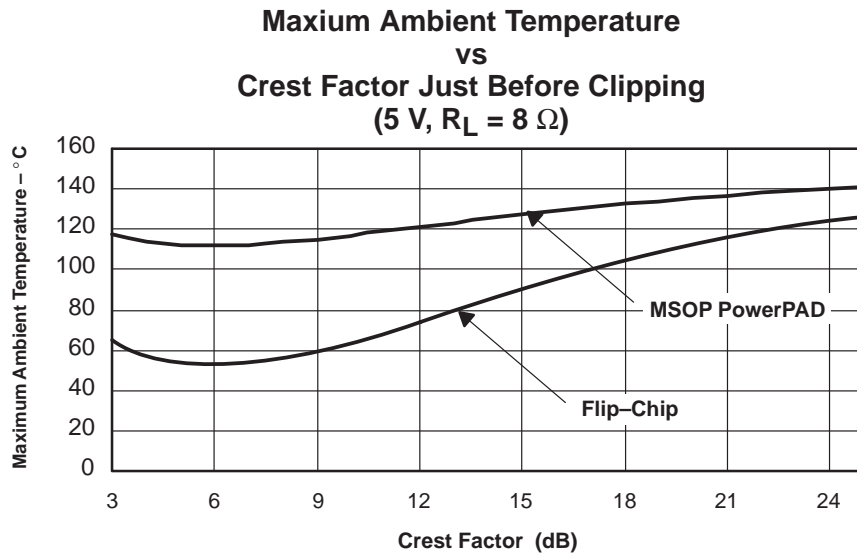

Figure 7. Maximum Ambient Temperature of a MSOP PowerPAD vs Flip Chip at 5 V

2.5 Class-AB versus Class-D

2.5.1 Power Dissipation and Efficiency

Linear amplifiers are notoriously inefficient. Class-D amplifiers were developed to increase the efficiency of audio-power-amplifier systems. A linear amplifier supplies a set amount of supply current for the desired output voltage. As discussed previously, the supply current equals the output current in a BTL class-AB amplifier. A class-D amplifier is a sampled system and delivers a set amount of power into the load for a given period. The class-D amplifier works at delivering the same amount of power from the power supply to the load by outputting a pulse-width modulated (PWM) signal and using the decoupling capacitor and the output filter inductance as energy storage elements. The PWM signal makes the output voltage switch between the supply rails, yielding very little voltage drop across the output transistors. The filter inductor and decoupling capacitor keep the current low. [1]

A class-D amplifier would have 100% efficiency because it attempts to supply an equal amount of power from the supply to the load. Unfortunately, losses in the system cause the efficiency to drop.

The output transistors have a resistance when *on* ($r_{DS(on)}$) greater than zero. This resistance causes a voltage drop in the output transistors, which leads to power dissipated. The amplifier's bias currents and gate charge also dissipate power. The power dissipated in the device can be calculated using equation 10.

$$P_D = P_L \left(\frac{r_{DS(on)}}{R_L} \right) + V_{DD} I_{DD(q) \text{ (no load or filter)}} \quad (10)$$

Once the power dissipated in the amplifier has been calculated, the maximum ambient temperature can be calculated using equation 8. Figure 8 shows the class-D amplifier in an MSOP PowerPAD with $R_L = 8 \Omega$, $r_{DS(on)} = 510 \text{ m}\Omega$ and $I_{DD} = 6 \text{ mA}$ compared to a class-AB in an MSOP PowerPAD and a class-AB in a flip-chip package. The plot clearly shows that the class-D amplifier is more efficient resulting in a lower junction temperature with the same package. This is not a serious problem with this device, but as power increases, a class-D amplifier can operate without a heatsink, while a heatsink is required for a class-AB amplifier.

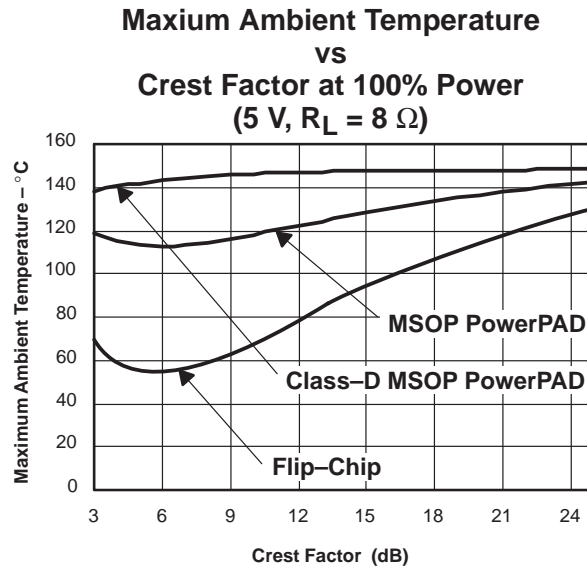

Figure 8. Maximum Ambient Temperature of Class-D vs Class-AB

In addition to less heat, a class-D device also offers improved battery life. To calculate the battery life savings, the efficiency of the entire class-D amplifier (including losses in the inductors and capacitors) must be calculated. The efficiency is the power to the load divided by the sum of the power to the load plus the dissipated power. Note that the resistance of the filter inductor ($DCR_{FILTER L}$) and the quiescent current of system with the filter are taken into account in the efficiency.

$$\text{Efficiency} = \frac{P_L}{P_L + \frac{P_L(2 \times r_{DS(on)} + DCR_{FILTER L})}{R_L} + V_{DD} I_{DD(q)} \text{ (with filter)}} \quad (11)$$

2.5.2 Class-D Modulation Scheme and Output Filter

The most common class-D modulation scheme uses a differential output PWM that is filtered and fed into the speaker. The duty cycle of each output is 50% with no output. The duty cycle of the positive output is greater than 50% and the duty cycle of the negative output is less than 50% to generate a positive output. Figure 9 shows how this class-D modulation scheme works.

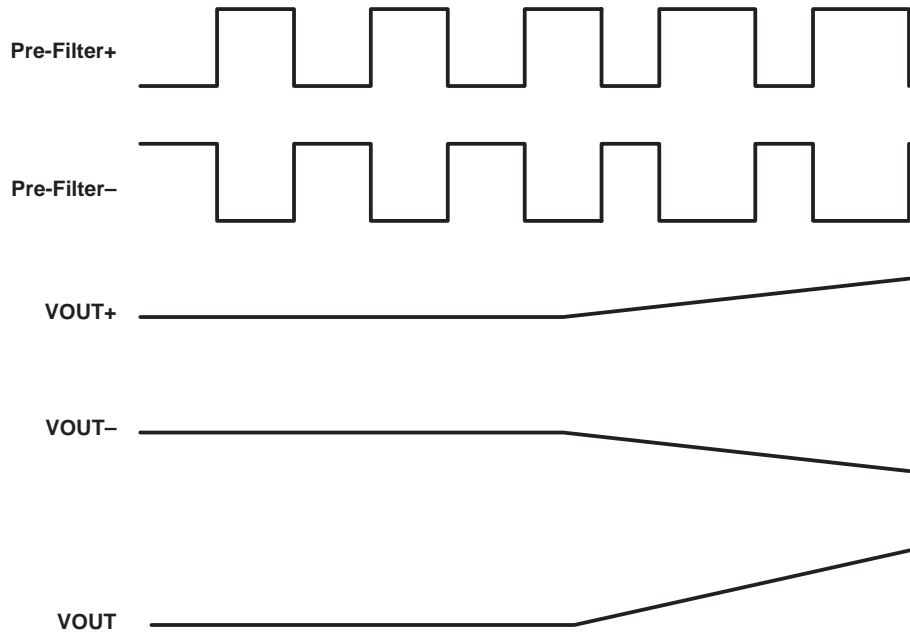

Figure 9. Common Class-D Modulation Scheme

The advantage of this class-D modulation scheme compared to the class-AB modulation scheme is improved battery life, lower heat dissipation, and lower power supply requirements. The disadvantages of the common class-D modulation scheme compared to class-AB are higher device cost, larger device size, filter required, and generally higher quiescent current.

2.5.3 Common Class-D Modulation Scheme Filter

A LC filter is required to limit the supply current and to filter EMI. A second-order Butterworth filter is used in this example. The derivation can be seen in the TPA005D02 EVM manual [2].

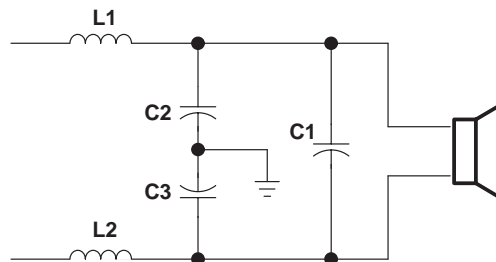

Figure 10. Class-D LC Low-Pass Output Filter

The filter is shown in figure 10. The inductor and capacitor equations are shown in equations 12, 13, and 14.

$$L1 = L2 = \frac{R_L}{\sqrt{2} \omega_o} \quad (12)$$

$$C1 = \frac{1}{\sqrt{2} R_L \omega_o} \quad (13)$$

$$C2 = C3 = 0.2 C1 \quad (14)$$

Inductors L1 and L2 are the same values as a standard Butterworth filter. Capacitor C1 is half the value of second-order Butterworth filter because it is acting as the filter capacitor for both positive and negative outputs. The capacitors C2 and C3 act as common mode filters to short any high frequencies to ground.

2.5.4 Texas Instrument's Filterless Class-D Modulation Scheme

The required filter is the primary disadvantage of the previously discussed class-D modulation scheme. The common class-D modulation scheme can be used without a filter, but the supply current is so high without a filter that it cancels any advantages that class-D brings in efficiency. The PWM waveform is the sum of the switching waveform and the input audio signal with gain. The human ear acts as a band-pass filter, such that only the frequencies between approximately 20 Hz and 20 kHz are passed. The switching frequency is much greater than 20kHz, so the only signal heard is the input audio signal with gain.

In the common class-D modulation scheme without a filter, the switching waveform is dissipated in the speaker, which leads to a higher supply current. This is because the speaker is both resistive and reactive and the common class-D switching waveform always has a supply voltage applied across the speaker. The new modulation scheme has only a very short differential pulse that could be dissipated in the speaker, so the supply current increase is less than 1 mA with a load that appears inductive or resistive at the switching frequency. Figure 11 shows the output waveforms of the newly implemented class-D modulation scheme.

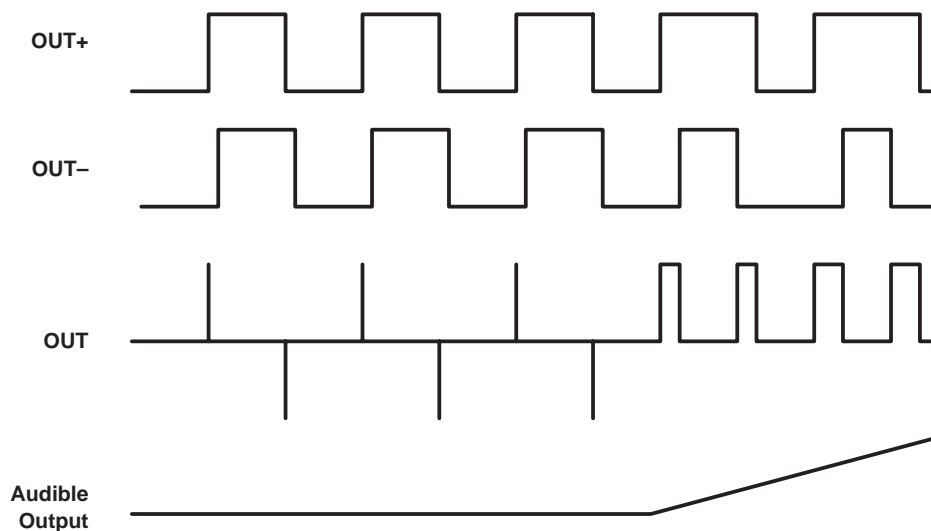

Figure 11. New Modulation Scheme

3 Overall System Block Diagrams

In this section, several audio system architectures are presented. These include: the ear-bud speaker, ear-bud with hands-free mode, stereo headphones, and car kits. The general architecture for all these solutions consists of a DSP, a voice-band audio processor (VBAP) including a CODEC, and an audio power amplifier. Since each of these system architectures is different, several different audio power amplifiers are used. Audio amplifier suppliers continue to come out with new and improved amplifiers, so it is important to get periodic updates on the latest devices available.

3.1 Ear-Bud Speaker

A very popular feature is the so-called ear-bud speaker combined with an inline microphone. This allows users to go hands-free, giving them more convenience, and more safety while driving. This architecture is commonly realized using an amplifier that has a control pin to select the amplifier's mode of operation: either single-ended (SE) or bridge-tied load (BTL). The internal speaker is driven in BTL mode, while the ear-bud is driven in SE mode. As discussed previously, the main advantage of BTL operation is the elimination of the dc blocking capacitor.

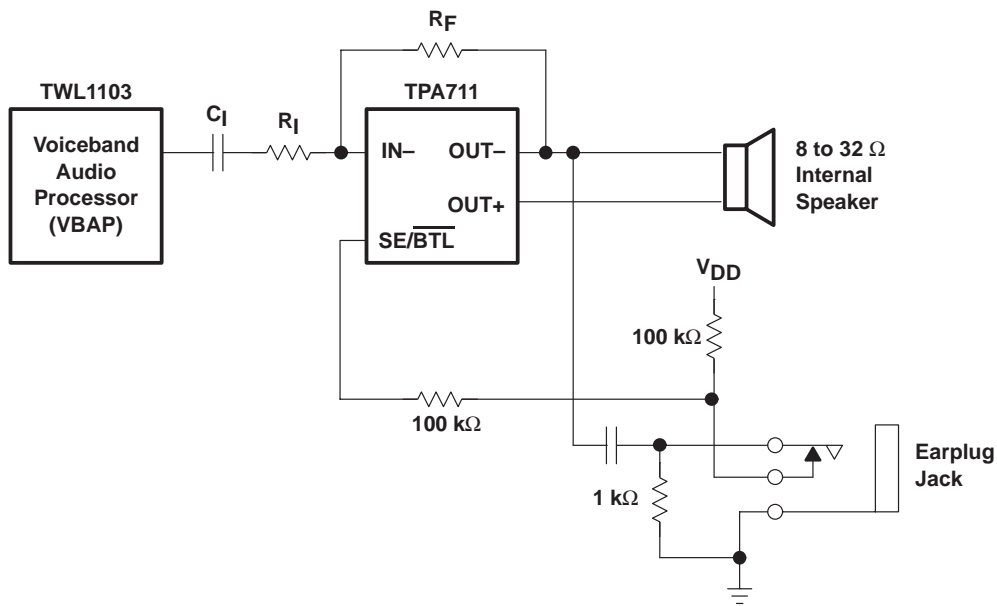

Figure 12. Ear-Bud and Internal Speaker

Figure 12 depicts one implementation of the ear-bud speaker feature in a wireless phone. In this example, the amplifier is using a single-ended input signal in order to use an 8-pin package. The output driving the internal speaker is configured in BTL mode. A control pin allows the amplifier to switch to SE mode when the ear-bud is plugged into the phone. As shown in the figure, the resistor divider consisting of a 100-k Ω resistor to V_{DD} , and a 1-k Ω resistor to ground is connected to the jack, and triggers the SE/BTL terminal. This causes the negative output to go into a high-impedance state, resulting in the internal speaker being muted. Several other actions may be triggered by this event: the display on the phone may change to recognize the ear-bud is in use, and the system will issue a command to the VBAP to reduce the gain. This is necessary as headphones and ear-buds typically have much better efficiency than the internal speaker. Remember also, that switching from BTL to SE automatically gives a 6 dB decrease in gain. The gain in BTL-mode is $-2 \times (R_F/R_I)$, and in SE-mode, it is reduced to $-R_F/R_I$. Power amplifiers used in these kinds of applications range from 300 mW to 700 mW. For example, the TPA711 is capable of delivering 700 mW to an 8- Ω load when driven by a 5-V power supply, and 270 mW to an 8- Ω load when driven by a 3.3-V power supply. In both cases, the output power is measured at a frequency of 1 kHz, and with a THD+N of 0.3 %.

3.2 Ear-Bud Speaker With Hands-Free or Walkie-Talkie Mode

In some applications, it may be necessary to have more power delivered to the internal speaker; for example, a phone with a hands-free or walkie-talkie mode of operation. Figure 13 shows a typical application circuit for an amplifier capable of delivering 2 watts of output power to a 4- Ω load from a 5-V power supply, or 1 watt of output power to a 4- Ω load from a 3-V power supply. While the circuit is very similar to the previous circuit, the amplifier in this example, the TPA0211, has a two-stage architecture consisting of a preamplifier stage, and a power amplifier stage. The feedback resistor has been integrated, so only an input resistor is needed to set the gain. The gain in BTL-mode is given by $125 \text{ k}\Omega / R_I$. The gain in SE-mode is given by $62.5 \text{ k}\Omega / R_I$. Note that, due to the two-stage architecture, the gain is not inverting.

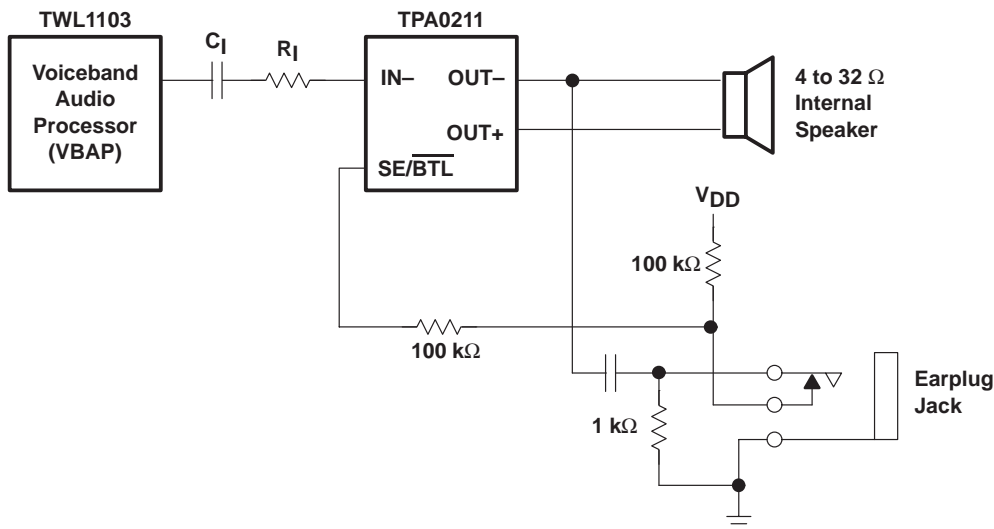

Figure 13. Ear-Bud and 2-W Internal Speaker

3.3 Mono Internal Speaker, Stereo Headphones

With the processing power of a DSP onboard, and the explosion of digitally-distributed music, a differentiating feature that can easily be added to a wireless phone is a digital music player. For the best user experience, stereo headphones are required, in addition to the mono speaker in the handset. There are several different solutions to implementing this *three-channel* solution. Figure 14 depicts a solution using two audio power amplifiers, one for the BTL internal speaker, and a second one for the SE headphone output signal. The benefit of this type of architecture is that a mono amplifier can be chosen that allows ear-bud operation, as well. However, in this example, a mono amplifier with differential inputs has been chosen to improve noise immunity in the handset speaker. A differential-input amplifier has also been chosen for the headphone drive. A high-side power switch is used to power down the D/A and amplifier when not in use to extend battery life.

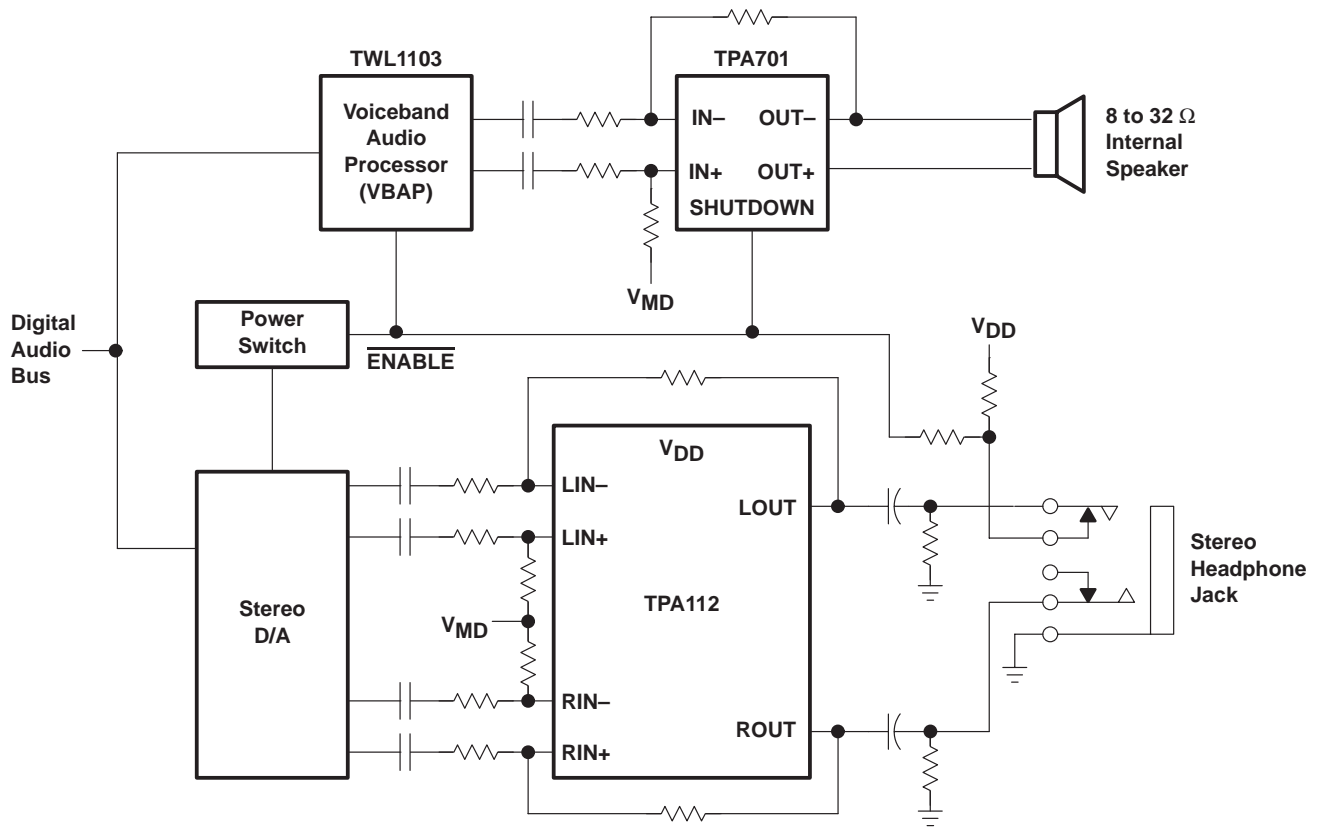

Figure 14. 700-mW Mono Internal Speaker and Stereo Headphones

Figure 15 depicts another circuit to provide the three-channel solution needed. This solution uses only a single amplifier that was designed with this functionality in mind. When required to drive the BTL internal speaker, the amplifier is configured as a mono BTL driver, with the input coming from the MIN terminal. When the headphones are inserted, the amplifier reconfigures itself to drive two SE outputs, with the inputs coming from the LIN and RIN terminals. This device, the TPA0213, provides up to 2 W into a 4- Ω speaker from a 5-V supply, or 1 W of output power to a 4- Ω speaker from a 3-V power supply. This amplifier has a similar architecture to the TPA0211—it has a two-stage arrangement consisting of a preamplifier stage, and a power amplifier stage. The feedback resistor has been integrated, so only an input resistor is needed to set the gain per channel. The gain in BTL-mode is given by $125 \text{ k}\Omega / R_I$. The gain in SE-mode is given by $62.5 \text{ k}\Omega / R_I$. Note that, due to the two-stage architecture, the gain is not inverting. Since the gain can be set separately for the internal speaker, and headphones, it is possible to optimize the gains separately.

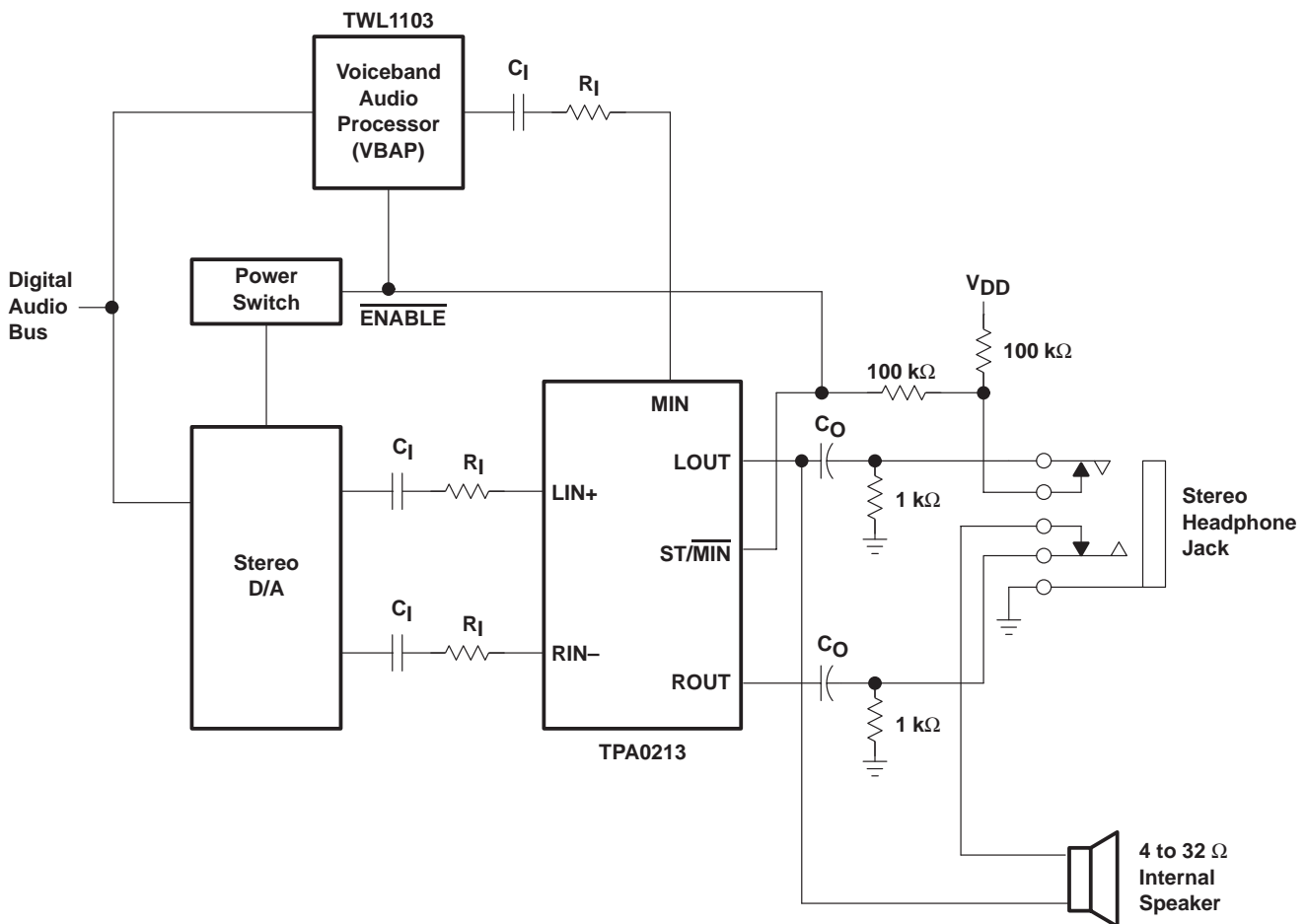

Figure 15. 2-W Mono Internal Speaker and Stereo Headphones

3.4 Cost-Driven Car Kit

As legislation and general safety concerns about using wireless phones while driving continue to proliferate, the popularity of car kits for wireless phones continues to grow. Figure 16 depicts an amplifier block diagram for a low-cost analog car kit. Combined with a microphone, microphone preamplifier, and possibly a charging circuit, this could be a complete solution that addresses the low-end of the car kit market.

In the amplifier portion, the analog audio signal is sent from the phone to the audio amplifier. This solution assumes that the volume control is done in the phone. If local volume control is needed, a potentiometer could be added in the audio stream, or for better audio quality, an amplifier with built-in volume control could be selected. Three types of volume control are commonly available: dc volume control, digital (via UP/DOWN digital input terminals on the amplifier), and I2C bus-controlled volume control. A big advantage to doing volume control in the car kit is that the analog audio signal from the phone can be at maximum amplitude to minimize noise pick-up. The volume control in the car kit then attenuates the audio signal the desired amount.

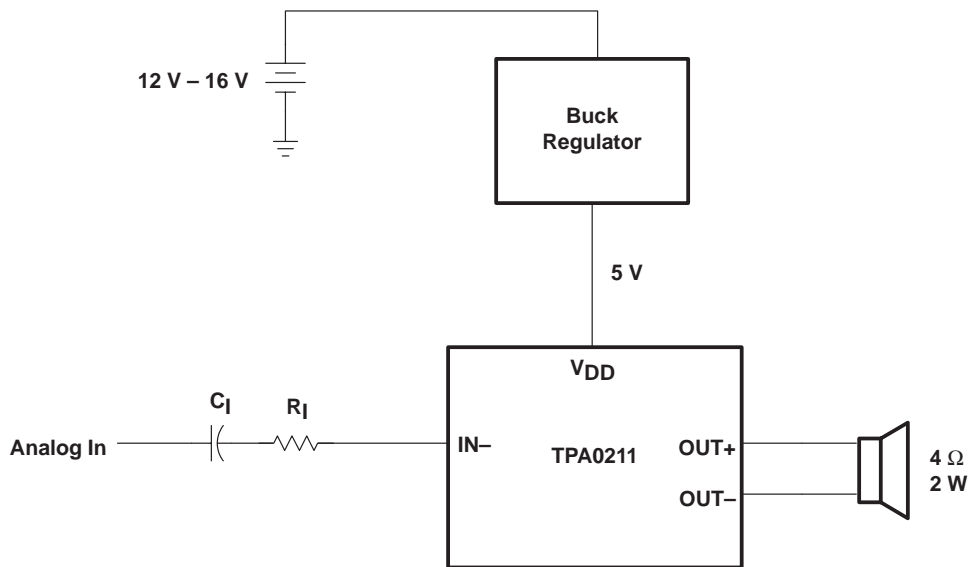

Figure 16. Low-Cost 2-W Car Kit

3.5 Feature-Driven Car Kit

Some users may require higher performance, and more features than available in the cost-driven car kit described above. Figure 17 depicts a higher-performance car kit. At the heart of this car kit is a mono, 12-V Class-D audio power amplifier. This amplifier is capable of delivering 11-W of clean power to the speaker without any heatsinks. It is packaged in a TSSOP PowerPAD package which can be automatically assembled using standard SMD processes. Since the amplifier operates with extremely high efficiency, it also minimizes the power dissipation inside of the car kit, allowing a smaller, or even, plastic box. In this circuit, a VBAP is used to allow a digital interface between the phone and the car kit, eliminating any noise pickup that would be common in an analog implementation. The use of a digital interface also allows the use of a DSP while minimizing the number of analog/digital conversions. This DSP is used for signal processing in the car kit.

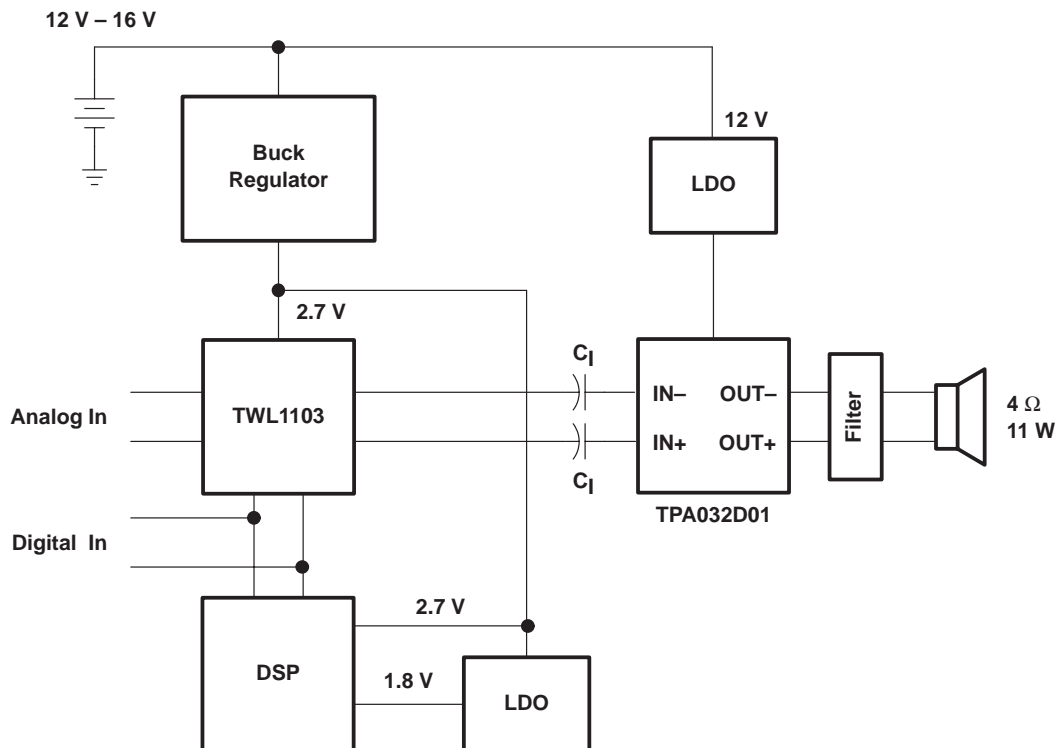

Figure 17. Feature-Rich 11-W Car Kit

4 Wireless Market Trends

4.1 Supply Voltages

Currently a 3.6-V battery is used with a voltage of 2.7 V to 4.5 V that is regulated for DSP supply voltages. The audio power amplifier can run directly from the battery of the phone. Some manufacturers are adding a 5 V boost regulator to increase output power. Most Texas Instruments audio power amplifiers have operating ranges from 2.5 V to 5.5 V to cover this range of voltages. The need for lower supply rails is not as pressing as the PC and PDA markets. Most phone manufacturers seem set on the 3.6-V lithium-ion battery for now.

4.2 Volume Control

Recently, audio amplifiers have added the capability of volume control to their feature set. It is important when choosing a power amplifier with volume control that the gain is added as a preamplifier, and not around the power stage. As the gain around the power stage is increased, the fidelity decreases.

There are three primary types of volume control. The first is dc volume control. This takes a dc voltage into a pin and translates that voltage into a gain for the preamplifier. An advantage with the dc volume control is that it just takes two pins (Volume control, and clock) for 32 or more volume settings. DC volume control could be controlled by a D/A converter, or a potentiometer.

Up/down volume control is another form of changing the gain on the fly. The up/down control requires three pins: up, down and clock. A microprocessor could control the gain settings by clocking them up and down. This could also be done with push buttons and a set internal clock, but a disadvantage of not using the microprocessor is that the user would not be able to tell where the volume level is set.

A third form of volume control is through a serial interface such as I2C. Many VBAP ICs have these capabilities already, having control of the audio power amplifier is just the next step. The advantage of a serial interface is that more settings than just volume can be set with this serial interface.

4.3 Packaging

Packaging is very important to the space critical and temperature sensitive wireless phone. Therefore, packages need to be small and still dissipate heat. Previously, wireless phones used an audio power amplifier in an SOIC package. SOICs are large and have a thermal impedance of approximately 172 °C/W. Wireless phones now use a MSOP PowerPAD package. It is about half the size and has a thermal impedance of just 58.5 °C/W. The thermal impedance of the PowerPAD package is very dependent upon PCB layout.

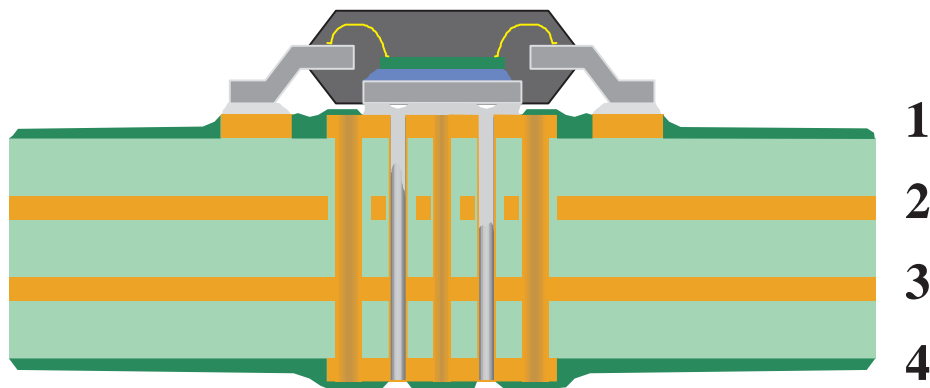

Figure 18. PowerPAD Layout for a 4-Layer

Figure 18 shows a MSOP PowerPAD package mounted on a 4-layer board. Heat will flow away from the die predominantly through paths with a lower thermal impedance. Most of the heat will flow down through the thermal vias into the ground plane layer, though some heat does escape from the top of the device, but this is a small amount as compared to what flows through the PowerPAD.

The larger the area and layers of copper, the more heat the PC board can conduct away from the device. This technique is readily expandable to PCBs of many more layers. Below is a list of design rules to use when laying out a PC board with PowerPAD. [3]

- Thermal pad is electrical GND for circuit connections.
- Use 20 mil (0.51 mm) diameter thermal vias near corner leads (small size not as critical as thermal pad vias). Additional vias outside of the PowerPAD area are desirable if PCB area is available.
- Thermal vias should **not** use WEB connections.

- Use 13 mil (0.33 mm) dia vias in thermal pad area to reduce solder wicking from thermal pad to underside (solder side) of PCB.
- Solder mask on solder side should leave no more than 2 mil (0.05 mm) annular ring to further help eliminate solder wicking through the thermal pad vias to the reverse side of the PCB.
- The number of vias used depends on the package size, and is chosen to provide the optimal balance between thermal connection to heat dissipation layer and minimal solder wicking from thermal pad area. The exact number of vias can be found in [3].
- A solder stencil of 7 mils is recommended.

5 Conclusion

The audio power amplifier is a critical component in the wireless phone. As features are added to the wireless phone, it becomes more important to choose the correct audio power amplifier. Differential inputs cancel common-mode noise and have much better RF immunity. Using an amplifier with bridge-tied-load outputs gives 4 times the output power of a single-ended output for a the same supply voltage. Choosing the right package that is compact, yet stays cool under high output power is important. Class-D amplifiers offer extended battery life and less power dissipation, and filterless class-D makes class-D possible in wireless phones. The many different phone options like ear-bud, stereo headphone, hands-free mode, and car kits require different audio power amplifiers.

References

1. Score, Michael. *Class-D Audio Power Amplifiers: What Makes Them so Efficient*. Wireless Symposium/ Portable by Design Conference. February 1999.
2. *TPA005D02 Class-D Stereo Audio Power Amplifier Evaluation Module Users Guide*, Texas Instruments, Inc., September 1998, literature number SLOU032.
3. *PowerPAD Thermally Enhanced Package*, Texas Instruments, Inc., November 1997, literature number SLMA002.

IMPORTANT NOTICE

Texas Instruments and its subsidiaries (TI) reserve the right to make changes to their products or to discontinue any product or service without notice, and advise customers to obtain the latest version of relevant information to verify, before placing orders, that information being relied on is current and complete. All products are sold subject to the terms and conditions of sale supplied at the time of order acknowledgment, including those pertaining to warranty, patent infringement, and limitation of liability.

TI warrants performance of its semiconductor products to the specifications applicable at the time of sale in accordance with TI's standard warranty. Testing and other quality control techniques are utilized to the extent TI deems necessary to support this warranty. Specific testing of all parameters of each device is not necessarily performed, except those mandated by government requirements.

Customers are responsible for their applications using TI components.

In order to minimize risks associated with the customer's applications, adequate design and operating safeguards must be provided by the customer to minimize inherent or procedural hazards.

TI assumes no liability for applications assistance or customer product design. TI does not warrant or represent that any license, either express or implied, is granted under any patent right, copyright, mask work right, or other intellectual property right of TI covering or relating to any combination, machine, or process in which such semiconductor products or services might be or are used. TI's publication of information regarding any third party's products or services does not constitute TI's approval, warranty or endorsement thereof.

Mailing Address:

Texas Instruments
Post Office Box 655303
Dallas, Texas 75265