

COP820,COP840

AN-1058 Using the COP820CJ/COP840CJ in Home Appliances



Literature Number: SNOA384

Using the COP820CJ/ COP840CJ in Home Appliances

National Semiconductor
Application Note 1058
Abdul Aleaf
November 1996



Using the COP820CJ/COP840CJ in Home Appliances

INTRODUCTION

The COP820CJ/COP840CJ family of devices offer a broad range of features to meet the requirements of household appliances such as coffee machines, irons, shavers, and cleaners in addition to washing machines, dryers, and air conditioning, where the introduction of electronics helps to provide product differentiation.

Until recently, appliances have been quite simple minded. They do one thing and, unless they run into a novel situation, they do it very well. One of the great benefits of the electronic revolution is that it brought intelligence, and with it adaptability, to traditional electro-mechanical devices. By continuously gathering information on the performance of the device, its operating environment and other factors, microchip intelligence can determine a new and proper strategy and then command the surrounding device to react.

Appliance manufacturers can find single chip microcomputers such as the COP820CJ/COP840CJ designed for consumer applications where safety is critical. Safety systems have been available on more expensive systems, such as

large computers and factory control panels for a number of years. It is significant that new microcontrollers incorporate safety features into a single silicon chip at a low enough price. In addition to safety requirements, the electronic systems incorporated into household appliances must be low cost, reliable, and able to perform tasks such as sensor measurements, heat control, LED drive and keyboard control.

EXAMPLE OF AN APPLIANCE APPLICATION

Today, microcontrollers have been specially designed for the appliance market. The integrated safety features, timers, and special I/O ports allow the implementation of many household appliance control systems using just one integrated circuit and very few passive components.

Figure 1 shows an example of such a microcontroller. The main features targeted at the appliance applications are Brown Out detection, WATCHDOG™, comparator, high current I/O, and special timers.

The use of these features are described using an appliance with heating control as an example.

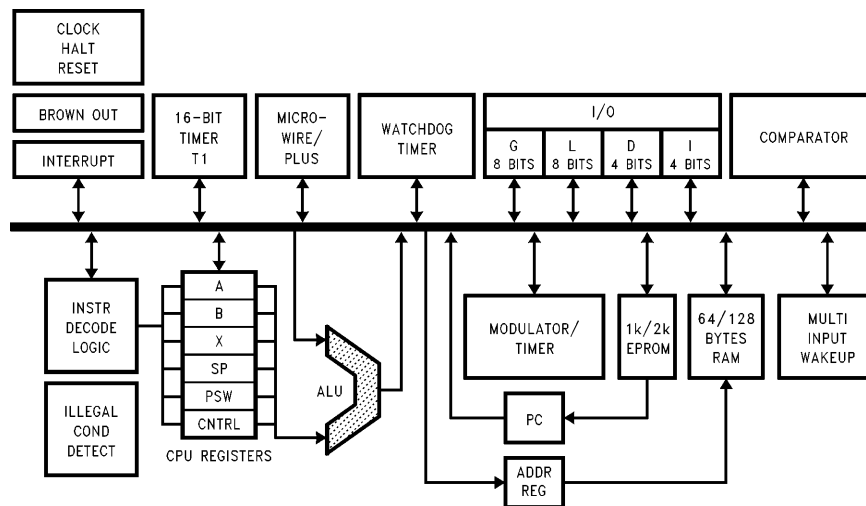

FIGURE 1. COP820CJ/COP840CJ Microcontrollers Block Diagram

TL/DD/12884-1

WATCHDOG™ and COP8™ are trademarks of National Semiconductor Corporation.

Figure 2 shows the circuit diagram for such an appliance for example a coffee maker. Most of the home appliance applications share common functions. The controller measures the temperature using a temperature dependent resistor and controls the heating coil via a relay. An LED display is used to indicate the mode of operation and the time remaining before the process is completed. A buzzer and a set of switches complete the user interface.

As mentioned earlier, one of the most important design criteria in any household appliance is safety. In this example, the design implementation must ensure that the heater is not held on for long periods under a fault condition. One common cause of processor failure is "Brown Out" on the power supply line. When deriving the supply voltage for the electronic circuitry directly from the "mains" by using voltage rectifier and passive components instead of using a

decoupling transformer (Figure 3), the controller could encounter "Brown Out" conditions. This condition occurs when the V_{CC} voltage drops below the minimum permissible value, causing the RAM and registers to be corrupted before returning to its normal value. In comparison to a "black-out" condition, which would discharge the power-on reset circuitry and cause a reset, the Brown Out condition puts the processor into a potentially dangerous, undefined state. Although, suitable decoupling of the V_{CC} can remove spikes of short duration, little can be done to prevent longer term mains drops without additional circuitry to detect the voltage level and to generate a reset if a Brown Out is detected. The cost of additional detection/protection circuitry if done externally is in the order of \$0.25 to \$0.35. This additional circuitry can be eliminated if the controller happens to provide the on-chip Brown Out circuitry.

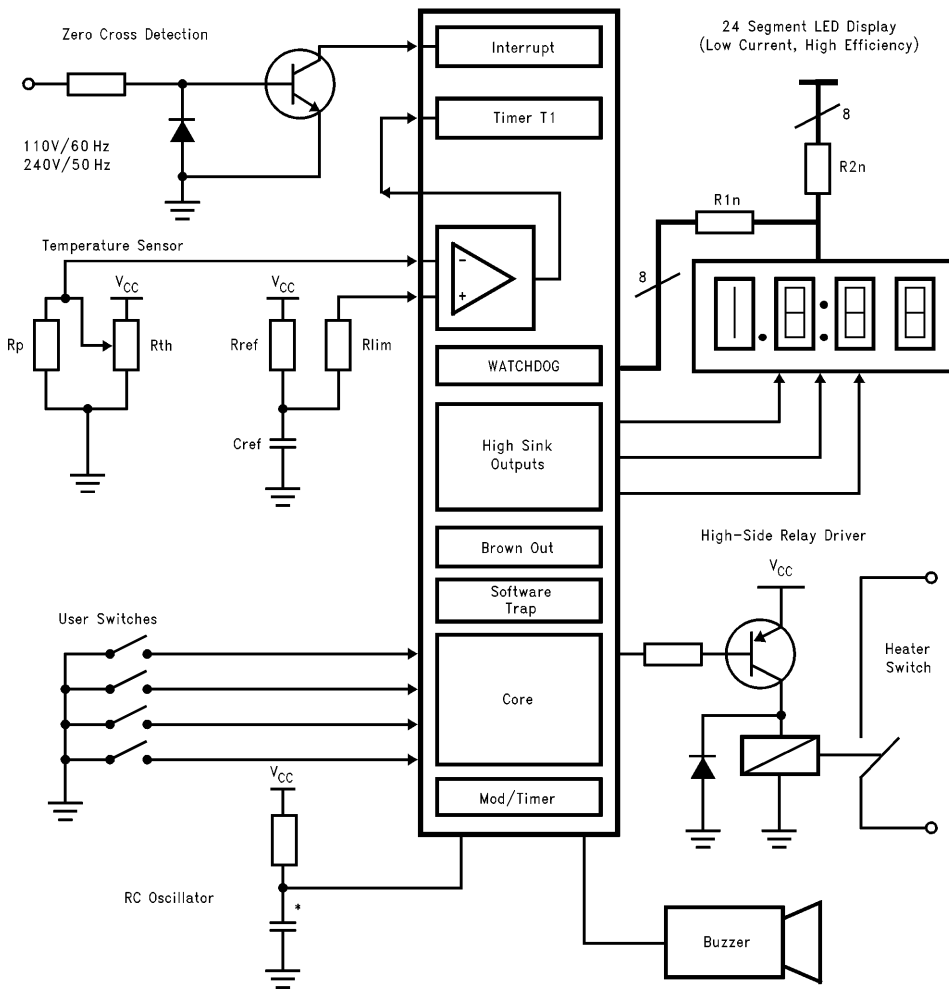

*Integrated on-chip on the COP840CJ.

TL/DD/12684-2

FIGURE 2. Temperature Controlled Appliance Using the COP820CJ/COP840CJ Microcontrollers

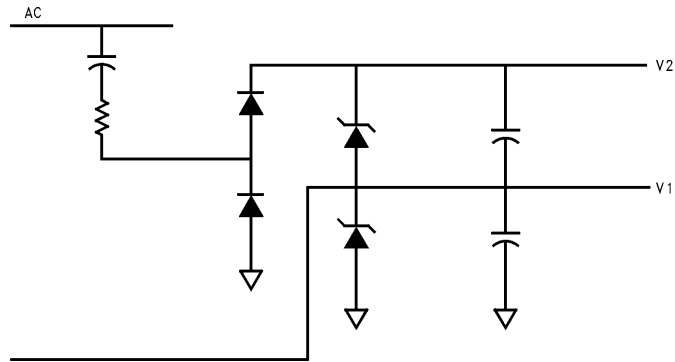

FIGURE 3. Low Cost Power Supply Circuit

TL/DD/12884-3

BROWN-OUT DETECTION

The on-board Brown Out detection circuit is for use in applications where temporary drops in the supply voltage (V_{CC}) could create potentially hazardous situations. This circuit monitors V_{CC} and compares it with the Brown Out circuitry trip voltage (V_{TRIP}). If the V_{CC} falls below the Brown Out trip

voltage, the microcontroller is held in reset. When V_{CC} rises above the Brown Out voltage, Brown Out initialization is generated, ensuring the program is restored to a defined state. *Figure 4* shows the equivalent circuit. *Figures 5* and *6* show the circuit operation.

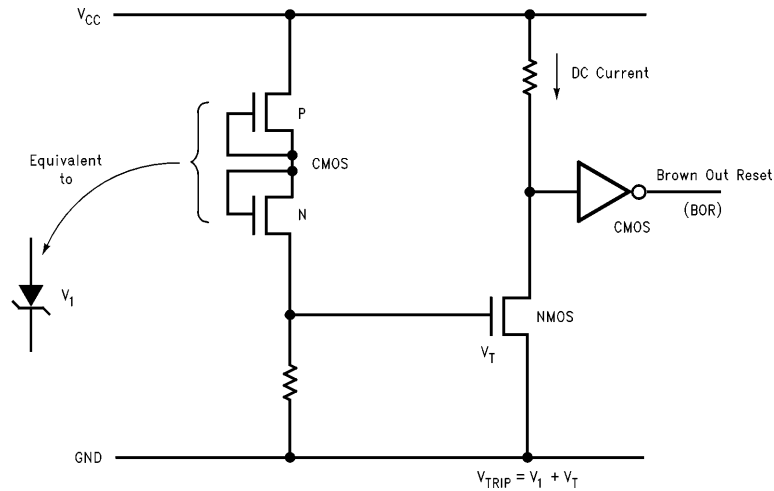
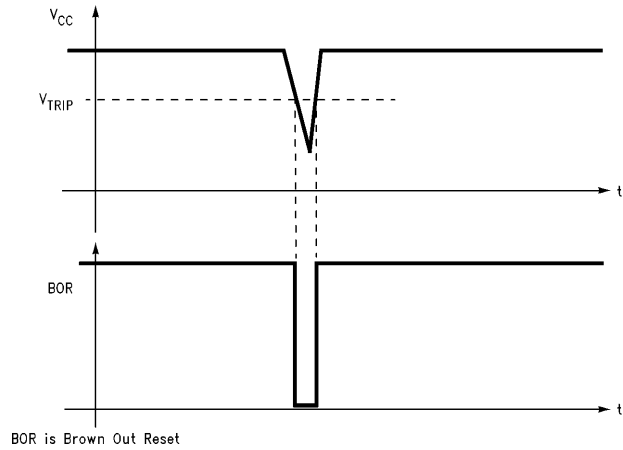

FIGURE 4. Brown Out Detection Equivalent Circuit

TL/DD/12884-4



BOR is Brown Out Reset

TL/DD/12884-5

FIGURE 5. Brown Out Circuit Trigger As a Result of V_{CC} Dip

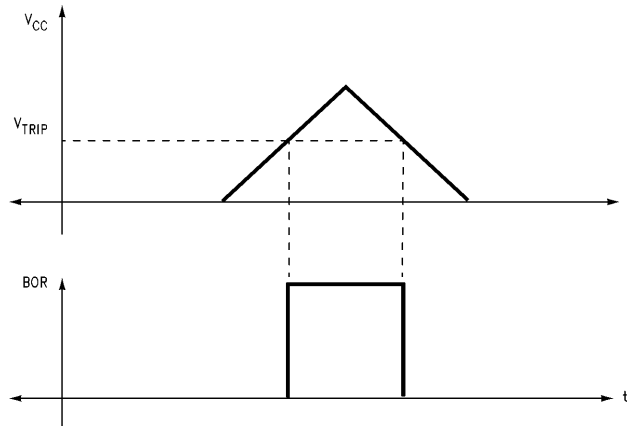

TL/DD/12884-6

FIGURE 6. Brown Out Circuit Trip as Function of V_{CC}

WATCHDOG RESET AND SOFTWARE TRAP

In addition to Brown Out detection, the controller could provide other levels of protection. Examples are the WATCHDOG circuitry and Software Trap on the microcontroller.

The on-board WATCHDOG circuitry is intended for use in applications where glitches or other sources of external interference could corrupt the program counter or the stack contents. This could cause the application software to be stuck in an infinite loop or to execute look-up table data, thus causing unpredictable behavior. The WATCHDOG timer is used to recover from such conditions. The user program should write periodically into the WATCHDOG counter before the counter underflows. The counter underflow causes a WATCHDOG reset. The value loaded into the counter determines the response time of the WATCHDOG circuit.

In addition to the WATCHDOG circuitry, the microcontroller contains the software trap feature. The software trap interrupt is used to detect errors in program execution. These errors result from a variety of conditions including: brown-outs, power transients, noise, runaway programs, over popping of the stack and accessing program memory locations which are not physically present in the device. A potential dangerous failure condition could be the case where the power supply (V_{CC}) may be preserved, but the program counter or stack could be corrupted, forcing the microcontroller into an undefined state. Software traps, like hardware interrupts, forces a jump to the interrupt service routine, which can detect the error and restart the program.

ZERO CROSS DETECTION

The zero-cross detection circuit used in this example gives an additional safety level to the appliance. The external interrupt pin G0 is provided with a square wave at the same frequency as the mains, generating an interrupt at regular intervals. If the interrupt enable flag is not corrupted, an external interrupt will cause the processor to execute the interrupt service routine, which can then check the stack to detect whether the processor was executing correctly before the interrupt or whether the processor was in an abnormal state.

The zero-cross detection circuit is primarily used as a time base for the appliance. The external interrupt pin can be configured to cause an interrupt on either a rising or a falling edge. If the software programs the controller to interrupt on a rising edge, a 20 ms time base will be generated. If the active edge is toggled, a 1 ms time base is produced. This gives the appliance an accurate time reference, allowing the design to use a cheap RC oscillator instead of a crystal or resonator.

TEMPERATURE CONTROL

The appliance measures the temperature using a thermistor which is linearized with a parallel resistor and connected to the on-board comparator. The output of this pair is connected to the inverting terminal comparator. The non-inverting terminal is connected to an RC network via a current limiting resistor. As the non-inverting terminal of the comparator is also a general purpose I/O port, the capacitor can be discharged by configuring this pin, as an output set to 0V. The capacitor discharges through the current limiting resistor. The pin is configured as the non-inverting terminal at the start of a conversion. The above configuration actually performs single slope Analog to Digital (A/D) conversion. This technique can be used to perform an A/D conversion using the on-board comparator in conjunction with an on-board timer. The first technique requires the RC product to be stable over temperature and component variation. The output of the comparator is routed to the input of the 16-bit timer set up in input capture mode. The timer is clocked every timing cycle (t_c), which is 10 times the clock period.

At the start of the conversion, the timer is cleared and started and the non-inverting terminal pin is configured as an input, causing the RC network to charge up. When the capacitor voltage reaches the inverting terminal voltage, the comparator switches from 0V to V_{CC} . This transition generates a capture event on the timer. The capture time is scaled to give the temperature reading. The capture event can generate an interrupt, if required, which prevents the processor from being idle during the conversion. For more information see Application Note 952.

INPUT/OUTPUT REQUIREMENTS

The I/O ports provided on the microcontroller are usually capable of driving LED display and other high current circuitry. For example, the microcontroller provides sufficient high current ports that can sink 10 mA to 15 mA. Therefore, high efficiency LED displays can be directly driven without using external transistors but at the cost of 8 current limiting resistors.

The relay is driven via a high-side PNP driver, because a break in either of the relay primary connections or a short to ground on the connection to the transistor will result in a safe condition on the load.

The buzzer is driven directly by a pin, which is the output of a dedicated timer. This timer can be configured to generate a square wave with desired on time. This allows the microcontroller to drive the buzzer without continual processor interventions. Certain I/O ports have Schmitt triggers on their inputs to give them an improved noise margin. This is particularly important in mains-driven applications.

INTERFERENCE IN APPLIANCE APPLICATIONS— ITS CAUSES AND ELIMINATION

Interference is one of the most difficult problems, when designing home appliance applications. Interference may disrupt the microcontroller operation and in extreme cases the on-chip detection and program recovery features may not be able to completely resolve the problem. This section presents the main sources of disturbance in microcontroller based appliance applications as well as possible solutions. Interference problems are more common in home appliance applications that use active power elements such as valves, relays, solenoids, power switches, triacs, and motors. Examples of such applications are washing machines and dryers.

INTERFERENCE FROM THE LINE SUPPLY

Cause:

This interference can come by switching components in the machine such as valves, heater and solenoids, or introduced directly from the line by other equipment connected to the same supply. This is a problem between phases of the network and should not be confused with earth and frame problems.

The noise signals can go to very high frequencies (several hundred kHz) and have a duration of 1 ms.

Solution:

A low pass filter must be inserted in the primary of the transformer of the power supply (Figure 7).

The coils used must be suitable for high frequency suppression, i.e. 0, 8 mH, $Q = 80$ at $f = 800$ kHz.

— A pi (π) filter is necessary to meet RFI measurements.

INTERFERENCE ON THE EQUIPMENT DC POWER SUPPLIES

Cause:

It is a bad practice to connect DC power supply from one module to another through the machine. These connections are unbalanced from the point of view of the noise induction because the ground (return) does not have the same impedance as the "active wire". This induced noise can have high energy and comes from both switching and running power elements in the machine. The inductive loads such as motor, heater, valves, relays are the major source of interference on the DC power. In such a situation even a good decoupling of the power supply on each module is not enough to cure the problem.

Solution:

Direct transmission of the AC power supply, each card has its own rectifiers and regulators (Figure 8).

In this way a new local ground is created on the board and is no longer related to the power supply source, which is now completely balanced against induced noise. The bridged rectifier is also balanced for noise by $2 \times 0.1 \mu\text{F}$ capacitors and will only work in common mode with the 50 Hz signal. This solution gives a very good rejection of interference.

It is highly discouraged to use a central tapped transformer to transmit the AC power supply (Figure 9). This leads to the same problems of DC transmission because it is fully unbalanced as the ground must also be connected.

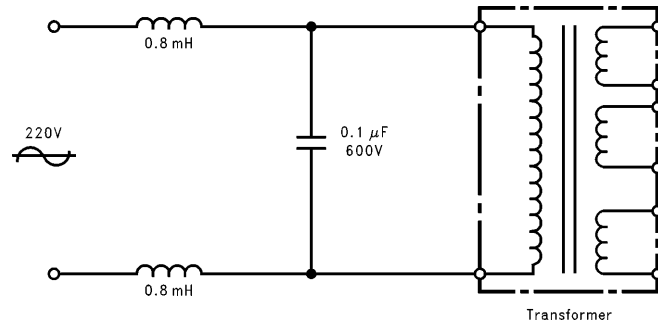

FIGURE 7. Interference from Line Supply

TL/DD/12884-7

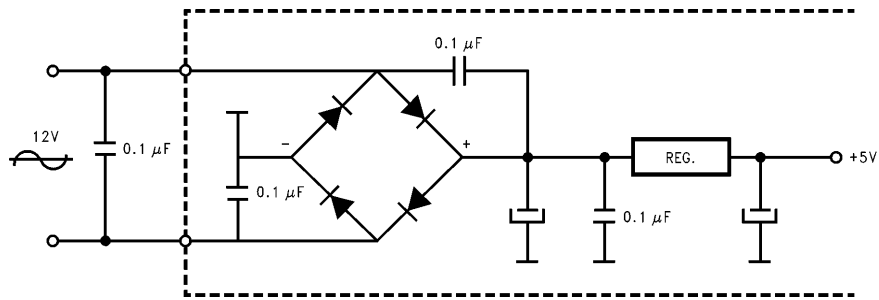

FIGURE 8. DC Power Supply

TL/DD/12884-8

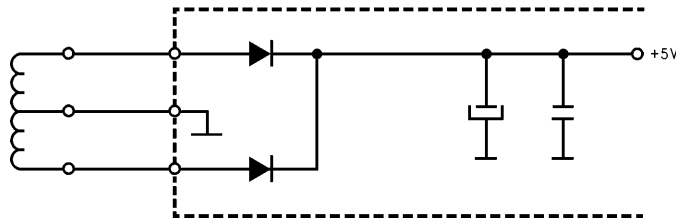

FIGURE 9. Central Tapped Transformer

TL/DD/12884-9

INTERFERENCE FROM THE MOTOR CONTROL

Cause:

If speed regulation, current regulation or both are needed, the commonly used technique is phase control of the motor. A frequently used motor is a universal type as this simplifies the torque problems. The commutating di/dt 's as well as the noise generated by the brushes and commutator of the motor can cause a lot of interference in the electronic system.

Solution:

An inductor of 1 mH fitted in series with supply of the motor (*Figure 10*). This coil must be rated for the current of the motor and have a good high frequency characteristic (100 kHz min).

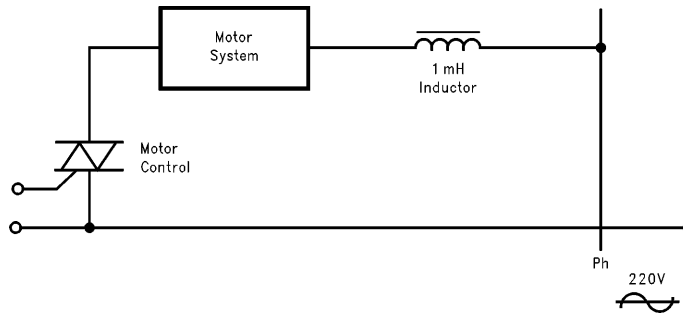

FIGURE 10. Motor Control

TL/DD/12884-10

The brushes of the motor can also be decoupled by a 10 nF–100 nF capacitor (1000V paper) to damp the noise of commutation, although this is marginal in its effectiveness. The motor feed back to the controller is a tachometer. This feedback can be either a frequency or amplitude signal.

If frequency measurement is used, problems could appear during low speed regulation when the frequency of the tachometer is the same order as that of 100 Hz induced noise.

The signal must have low impedance for the feedback circuitry and shielding the feedback line is advisable.

DRIVING RELAYS AND SOLENOIDS

If relays and solenoids are driven in DC, a flyback diode must be fitted across the coil to recover stored energy when switching off (Figure 11). This diode must be fitted close to the coil and not for example on the driving card, should it be remote from the load. This avoids current (inductive) loops through the system.

POWER SWITCHES AND “SHOWERING” EFFECT

Power switches used in appliance are subject to “showering” effect, especially as they age. Showering is not bouncing, it means that during the switching “ON”, there is a spark between the contacts of the switch (Figure 12). This spark is such that it can lead to a high frequency (500 kHz) chopping of the mains voltage applied to the system. This problem is solved for the power supply of the system by the filter fitted serially with transformer (Figure 7). Another problem still appears if triacs are used in the design. Triacs are sensitive to fast rising voltages and can “trigger on” by their own on high dv/dt. A snubber network between the main terminals solves this problem of computing dv/dt at 50 Hz but not for the showering effect because the frequency is too high.

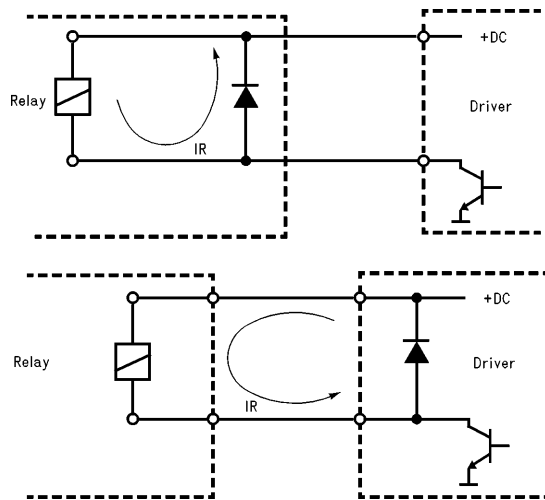

FIGURE 11. Driving Relays and Solenoids

TL/DD/12884-11

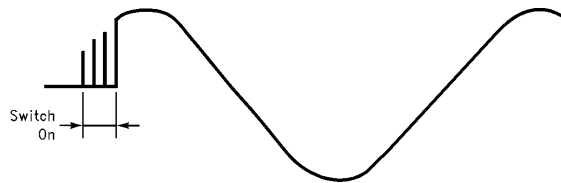

FIGURE 12. Power Switches and “Showering” Effect

TL/DD/12884-12

Due to this effect some valves, relays and even the motor can be switched on for a short duration when the machine is switched on.

Solution:

A capacitor is fitted in parallel across the contacts of the main switch (Figure 13).

INTERFERENCE ON THE INPUT/OUTPUT LINES OF THE MICROCONTROLLER

This is a common problem to every design, the general rules to eliminate these problems are:

1. Work with the I/O at the lowest possible impedance, low value resistances to either V_{CC} or the ground.
2. Use an RC low-pass filter on sensitive inputs. A capacitor on outputs may also be necessary.
3. Minimize the number of I/O lines running through the machine, by dividing the system into modules. Master module, slave module etc. The data communication between modules can easily be encoded in a way that has a good noise rejection.
4. Avoid using the ground of the microcontroller as common for the I/O going through the machine.

KEYBOARD CAN BE A GOOD ANTENNA!

The keyboard is usually a touch with metallized patches for the contacts.

It can act like an antenna for electrostatic and capacitive coupled interference's caused directly by the user of the machine. This causes problems when directly connected to the microcontroller I/O lines.

Solution:

Decoupling of the input lines by an RC network to damp and integrate the interference's (Figure 14).

CHOICE OF POWER ELEMENTS

Designing a complete system also means choosing the most suitable power element and driving method, here are several general rules:

1. Heaters are heavy loads (more than 10A) and have to be activated by relays, mainly for economic reasons. It is better here, to drive these relays in DC ($24 V_{DC}$ unregulated) by transistors.
2. Medium loads like pump motor can be driven by triacs rated at 5A to 8A and bring normally no problems.

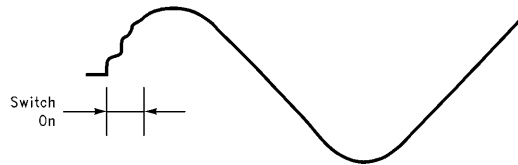
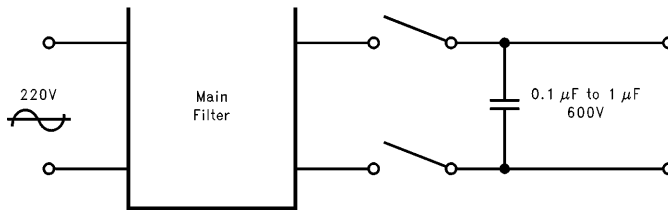

FIGURE 13. Switching "ON" Power Elements

TL/DD/12884-13

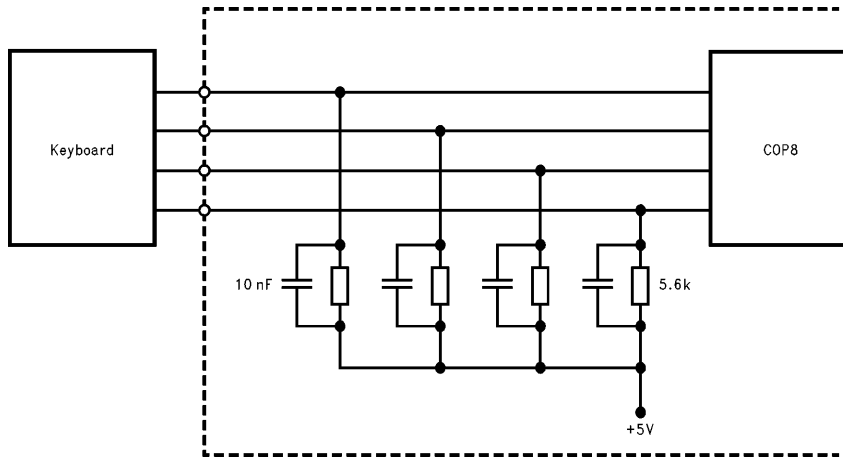

FIGURE 14. Keyboard Interface

TL/DD/12884-14

3. Small inductive loads like valves and door solenoids can be driven by 2A to 5A triacs. The snubber network must be compromised between dv/dt protection and the minimal safe current not switching on the load. The triacs must be selected with low "holding current" characteristic. A solution is also to ask for a customer selection for high dv/dt from the triac manufacturer when possible, this avoids using a snubber network.
4. Main motors must be driven by triacs if a current or speed regulation is needed. If forward/reverse mode is needed, the best compromise (economic and safety) is to use one triac for the regulation and on DPDT relay for reversing the direction. Compensation must, then, be given by the microprocessor's software to avoid activating the relay when the motor is on or just after it was on (motor recovery time). Such a protection boots up the life time of the relay to his mechanical rather than electrical limits.

A thermal door lock has, because of the principle of this devise (bimetallic), 8 to 10 seconds of reaction time before its contacts close.

If this switch, for example, is fitted serially with the motor circuitry, this fact could disturb the starting phase of the motor at beginning of a program.

5. A good way to reduce interference's coming from switching "on" inductive loads in AC, is to trigger the triacs not at zero crossing but with a certain delay angle. This reduces the inrush current of magnetization, the angle is related to the load's phase factor, i.e. for valves load's phase factor, i.e. for valves load takes about 60 lagging.

CONCLUSIONS

The electronic systems incorporated into household appliances must be low cost, reliable, safe and able to perform a number of tasks such as sensor measurement, triac control, LED display drive and keyboard control. One of the most important design requirements is safety. There are micro-controllers designed specifically for user safety. Manufacturers claim the stories about coffee makers burning up and starting household fires were a prime motivator in building these particular chips.

LIFE SUPPORT POLICY

NATIONAL'S PRODUCTS ARE NOT AUTHORIZED FOR USE AS CRITICAL COMPONENTS IN LIFE SUPPORT DEVICES OR SYSTEMS WITHOUT THE EXPRESS WRITTEN APPROVAL OF THE PRESIDENT OF NATIONAL SEMICONDUCTOR CORPORATION. As used herein:

1. Life support devices or systems are devices or systems which, (a) are intended for surgical implant into the body, or (b) support or sustain life, and whose failure to perform, when properly used in accordance with instructions for use provided in the labeling, can be reasonably expected to result in a significant injury to the user.
2. A critical component is any component of a life support device or system whose failure to perform can be reasonably expected to cause the failure of the life support device or system, or to affect its safety or effectiveness.



National Semiconductor Corporation
Americas
 Tel: 1(800) 272-9959
 Fax: 1(800) 737-7018
 Email: support@nsc.com

National Semiconductor Europe
 Fax: +49 (0) 180-530 85 86
 Email: europe.support@nsc.com
 Deutsch Tel: +49 (0) 180-530 85 85
 English Tel: +49 (0) 180-532 78 32
 Français Tel: +49 (0) 180-532 93 58
 Italiano Tel: +49 (0) 180-534 16 80

National Semiconductor Southeast Asia
 Fax: (852) 2376 3901
 Email: sea.support@nsc.com

National Semiconductor Japan Ltd.
 Tel: 81-3-5620-7561
 Fax: 81-3-5620-6179

<http://www.national.com>

National does not assume any responsibility for use of any circuitry described, no circuit patent licenses are implied and National reserves the right at any time without notice to change said circuitry and specifications.

IMPORTANT NOTICE

Texas Instruments Incorporated and its subsidiaries (TI) reserve the right to make corrections, modifications, enhancements, improvements, and other changes to its products and services at any time and to discontinue any product or service without notice. Customers should obtain the latest relevant information before placing orders and should verify that such information is current and complete. All products are sold subject to TI's terms and conditions of sale supplied at the time of order acknowledgment.

TI warrants performance of its hardware products to the specifications applicable at the time of sale in accordance with TI's standard warranty. Testing and other quality control techniques are used to the extent TI deems necessary to support this warranty. Except where mandated by government requirements, testing of all parameters of each product is not necessarily performed.

TI assumes no liability for applications assistance or customer product design. Customers are responsible for their products and applications using TI components. To minimize the risks associated with customer products and applications, customers should provide adequate design and operating safeguards.

TI does not warrant or represent that any license, either express or implied, is granted under any TI patent right, copyright, mask work right, or other TI intellectual property right relating to any combination, machine, or process in which TI products or services are used. Information published by TI regarding third-party products or services does not constitute a license from TI to use such products or services or a warranty or endorsement thereof. Use of such information may require a license from a third party under the patents or other intellectual property of the third party, or a license from TI under the patents or other intellectual property of TI.

Reproduction of TI information in TI data books or data sheets is permissible only if reproduction is without alteration and is accompanied by all associated warranties, conditions, limitations, and notices. Reproduction of this information with alteration is an unfair and deceptive business practice. TI is not responsible or liable for such altered documentation. Information of third parties may be subject to additional restrictions.

Resale of TI products or services with statements different from or beyond the parameters stated by TI for that product or service voids all express and any implied warranties for the associated TI product or service and is an unfair and deceptive business practice. TI is not responsible or liable for any such statements.

TI products are not authorized for use in safety-critical applications (such as life support) where a failure of the TI product would reasonably be expected to cause severe personal injury or death, unless officers of the parties have executed an agreement specifically governing such use. Buyers represent that they have all necessary expertise in the safety and regulatory ramifications of their applications, and acknowledge and agree that they are solely responsible for all legal, regulatory and safety-related requirements concerning their products and any use of TI products in such safety-critical applications, notwithstanding any applications-related information or support that may be provided by TI. Further, Buyers must fully indemnify TI and its representatives against any damages arising out of the use of TI products in such safety-critical applications.

TI products are neither designed nor intended for use in military/aerospace applications or environments unless the TI products are specifically designated by TI as military-grade or "enhanced plastic." Only products designated by TI as military-grade meet military specifications. Buyers acknowledge and agree that any such use of TI products which TI has not designated as military-grade is solely at the Buyer's risk, and that they are solely responsible for compliance with all legal and regulatory requirements in connection with such use.

TI products are neither designed nor intended for use in automotive applications or environments unless the specific TI products are designated by TI as compliant with ISO/TS 16949 requirements. Buyers acknowledge and agree that, if they use any non-designated products in automotive applications, TI will not be responsible for any failure to meet such requirements.

Following are URLs where you can obtain information on other Texas Instruments products and application solutions:

Products

Audio	www.ti.com/audio
Amplifiers	amplifier.ti.com
Data Converters	dataconverter.ti.com
DLP® Products	www.dlp.com
DSP	dsp.ti.com
Clocks and Timers	www.ti.com/clocks
Interface	interface.ti.com
Logic	logic.ti.com
Power Mgmt	power.ti.com
Microcontrollers	microcontroller.ti.com
RFID	www.ti-rfid.com
OMAP Mobile Processors	www.ti.com/omap
Wireless Connectivity	www.ti.com/wirelessconnectivity

Applications

Communications and Telecom	www.ti.com/communications
Computers and Peripherals	www.ti.com/computers
Consumer Electronics	www.ti.com/consumer-apps
Energy and Lighting	www.ti.com/energy
Industrial	www.ti.com/industrial
Medical	www.ti.com/medical
Security	www.ti.com/security
Space, Avionics and Defense	www.ti.com/space-avionics-defense
Transportation and Automotive	www.ti.com/automotive
Video and Imaging	www.ti.com/video

TI E2E Community Home Page

e2e.ti.com

Mailing Address: Texas Instruments, Post Office Box 655303, Dallas, Texas 75265
Copyright © 2011, Texas Instruments Incorporated