

# LM1823

*AN-391 The LM1823: A High Quality TV Video I.F. Amplifier and Synchronous  
Detector for Cable Receivers*



Literature Number: SNOA674

# The LM1823: A High Quality TV Video I.F. Amplifier and Synchronous Detector for Cable Receivers

National Semiconductor  
Application Note 391  
Martin Giles  
March 1985



The LM1823:  
A High Quality TV Video I.F. Amplifier and Synchronous Detector for Cable Receivers AN-391

## INTRODUCTION

The LM1823 is a video I.F. amplifier designed to operate at intermediate carrier frequencies up to 70 MHz, and employ phase locked loops for synchronous detection of amplitude modulation on these carrier frequencies. The high gain, wide AGC range and low noise of the LM1823 make it ideal for use in television receivers, video cassette recorders and in cable TV set-top converters requiring high quality detected base-band video and an audio intercarrier. Typical performance characteristics and features of this I/C are summarized in Table I below.

**TABLE I**

Maximum system operating frequency	70 MHz
Typical I.F. amplifier Gain (45.75 MHz)	> 60 dB
I.F. amplifier gain control range	55 dB
True synchronous detector with a PLL	
Detector conversion gain	34 dB
Detector output bandwidth	9 MHz
Detector differential gain	2%
Detector differential phase	1 degree
Noise averaged AGC system	
Internal AGC gated comparator	
Reverse tuner AGC output	
DC controlled video detection phase	
AFC detector	

## THE R.F. SIGNAL FORMAT

Despite the wide variety of signal sources available to the home television receiver—broadcast, cable, satellite, video games etc.—on channel carrier frequencies from 55.25 MHz to 885.25 MHz, the spectral content of each R.F. channel has been established for many years. In the United States the channel bandwidth is fixed at 6 MHz with the picture carrier located 1.25 MHz from the lower end of the band, and an aural carrier placed 4.5 MHz above the picture (pix) carrier. Introduction of color television in the early fifties added another carrier, the chroma sub-carrier, positioned 3.58 MHz above the pix carrier frequency. The pix carrier is amplitude modulated\* by the baseband video signal (which \* A more appropriate term is "negative downward modulation" since any modulating signal causes a decrease in the peak carrier amplitude (compared to conventional a.m., where the modulating signal alternately increases and decreases the peak carrier level with the mean carrier level remaining constant). For television carriers, syncs correspond to peak carrier and increasing brightness causes decreasing carrier amplitudes.

includes the synchronization information and the phase and amplitude modulated chroma subcarrier) while the aural carrier is frequency modulated. Television channels in Europe use similar carriers with the refinement of a fluctuating chroma subcarrier phase (P.A.L.).

The signal coming into the receiver has this general format and the receiver R.F. and I.F. circuits are designed to handle such a signal and reduce it back to the baseband composite video and audio intercarrier. Even where signal scrambling is used to protect the video modulation from unauthorized detection, the R.F. spectrum must remain within this format. For satellite broadcasts with frequency modulation of the video signal, the signal is demodulated and then remodulated onto a low VHF channel for reception by standard television receivers. In connection with this, the LM1823 PLL detector is not suitable for wide-band FM detection—even though the I.F. carrier (70 MHz) is well within the LM1823 I.F. amplifier frequency capability.

Notice again that the pix carrier is located at one end of the occupied bandwidth and only the upper sidebands are being fully transmitted. The lower sidebands are truncated with only frequencies close to the pix carrier frequency modulating the carrier. This method of conserving the frequency spectrum is referred to as vestigial sideband transmission.

## THE CABLE CONNECTION

Originally introduced many years ago as a means for providing broadcast TV to isolated areas or where the terrain made direct reception difficult, cable TV had modest growth in the U.S. and was a stagnating industry until the mid-seventies. Lower cost satellite earth stations were the turning point, allowing cable operators access to many varied program sources from any part of the country.

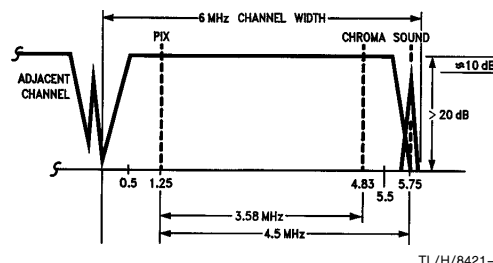

**FIGURE 1. U.S. Broadcast Channel Spectrum**

Broadcast Channel Frequency Allocations

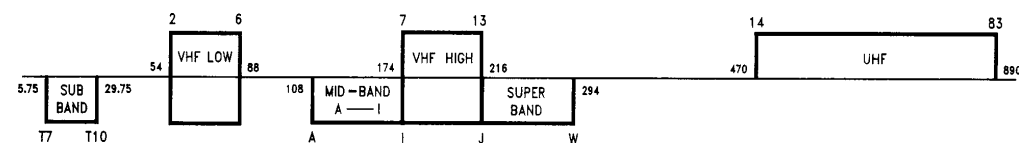

Cable Channel Frequency Allocations

**FIGURE 2. Broadcast and Cable Bands in the U.S.**

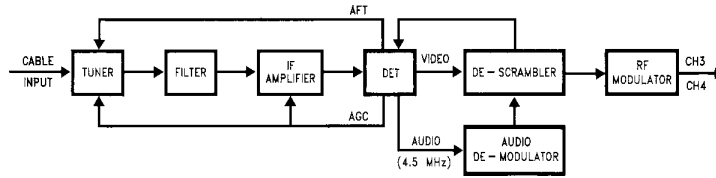

TL/H/8421-3

**FIGURE 3. Cable Set-Top Converter Block Diagram**

Standard television receivers in the U.S. tune to VHF channels 2 through 13 and UHF channels 14 through 83, and initially cable operators used the 12 VHF channels for their program material. With increased sources soon all channels were occupied on some systems creating significant demands on television tuner and I.F. amplifier strips. More space yet was needed and rather than using UHF channel allocations starting at 470 MHz because of cable signal attenuation (typically 0.8 dB/100 ft. at 300 MHz), operators turned to the unused spectrum space between VHF channel 13 and UHF channel 14. Naturally, since standard TV receivers could not tune to these channels, the set-top converter came into being. Each of the new channels could be converted to a low VHF channel to be received on the standard TV. Television manufacturers responded, and with the common introduction of varactor tuners were soon able to offer "cable ready" televisions capable of tuning to all the new cable frequencies. This meant that customer conveniences such as remote control of channel selection also became available. Unfortunately it aggravated a problem already confronting the cable operator. Since standard television receivers couldn't tune to the cable channels, operators had been able to offer premium services on some of these frequencies, paid for by subscribers who rented the appropriate set-top converter box. This didn't prove very secure since one operator's "free" channel was another operator's "pay" channel, and the introduction of cable-ready televisions ensured the eventual demise of such systems.

Scrambling the signal, a technique already being used by over-the-air subscription television, has become common in the cable service. The degree of scrambling\* is limited since the scrambled signal spectrum must remain within the channel allocation and anything done to the signal must be subsequently undone without noticeable degradation of the signal.

Generally for television, scrambling means a pulse or sine wave suppression of the signal horizontal blanking pulse interval so that the sync-tips occur between the black and white levels instead of always below black level. The standard television sync separator does not function well with this signal and the I.F./tuner AGC circuits will not work properly, effectively scrambling the displayed picture. Other techniques include random inversion of the video information to provide an even greater degree of security.

The means used to encode such a scrambled signal gives rise to the terms "in band scrambling" and "out of band scrambling". With cable ready television receivers capable of tuning to the scrambled channel, the decoder can be a simple broad-band gain switch (to change the signal R.F. amplitude during horizontal blanking) with a separate receiver tuned to the decoding data carrier frequency, which is

\*Other security techniques such as jamming or trapping are used but since jamming is easy to defeat and trapping requires removal or replacement of filters in the cable drop to individual subscribers, scrambling the signal is receiving a lot more attention.

located outside the signal channel. This permits use of the television receiver in a normal way but does require simultaneous switching of the decoder receiver with channel changes.

Also, spectrum space must be reserved for each scrambled channel's data carrier.

A more popular method of scrambling is "in band scrambling" where the data carrier to decode the signal is included inside the transmitted signal channel, usually within the aural carrier. Any number of channels can be scrambled and now different levels of service can easily be added or deleted without the need to rewire the decoder box. This is achieved by including time multiplexed binary "tags" along with the sync information so that special programs can be identified. Individual subscriber boxes can be similarly addressed and turned on or off by the cable operator. In these types of systems, the LM1823 and LM2889 have obvious applications. The LM1823 is able to provide an excellent baseband signal inside the decoder box, which signal is then remodulated on a low VHF channel carrier by the LM2889 for retransmission to the standard television receiver. Clearly, the highest possible performance is desirable to prevent any noticeable difference between a converted channel, whether scrambled or not, and a regular off-air broadcast channel. (For a complete description of the LM2889 modulator I/C see AN402).

#### THE RECEIVER FRONT-END

The typical receiver front-end consists of a tuner, I.F. amplifier, I.F. filters and a video/sound intercarrier detector stage. These circuits are designed to provide a number of functions:

- 1) Select (tune) a specific R.F. channel in a band of frequencies.
- 2) Provide rejection to adjacent and other channels in the band.
- 3) Amplify low level R.F./I.F. signals prior to detection of the modulation.
- 4) Avoid overload on high level R.F. signals.
- 5) Trap or attenuate specific frequencies within the channel bandwidth to ensure a proper detected frequency response is obtained.
- 6) Linearly demodulate all desired modulating frequencies on the carrier.
- 7) Produce a noise-free video signal at the detector.
- 8) Provide automatic gain control (AGC) to compensate for changing signal strength at the receiver input.
- 9) Provide automatic frequency control (AFC) to the tuner local oscillator (L.O.) to maintain the carrier intermediate frequency (I.F.).

**N.B.** Items 8) and 9) have previously been provided in part by circuits external to the conventional I.F. amplifier. However, these functions are completely included with the LM1823 leading to overall performance improvements and reduction in external parts count and cost.

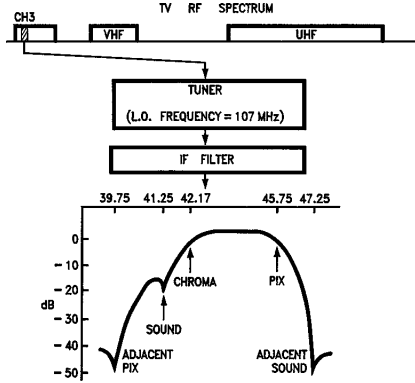

TL/H/8421-4  
**FIGURE 4. R.F. Tuning and I.F. Conversion (Note High Side L.O. Reverses the Relative Position of the Picture Chroma & Sound Carriers. c.f. Figure 1).**

Although we are not directly concerned with the tuner design in this application note, it is useful to understand the design goals and constraints on the tuner for at least two reasons. First, since the tuner and I.F. amplifier interact very closely to obtain and maintain a noise-free picture, we need to know something about the tuner in order to provide the correct gain distribution and AGC action. Second, when the two functions are finally placed together, we need to know where to look to solve visible problems that may have become apparent. In some instances, either the tuner or the I.F. amplifier may be at fault, and a good understanding of the system interaction is needed to ensure that the appropriate action is taken.

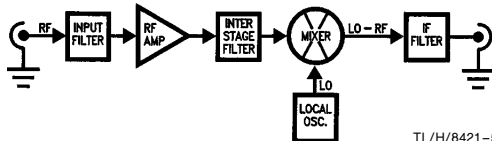

TL/H/8421-5  
**FIGURE 5. Typical Single Conversion Tuner**

Both single conversion and double conversion techniques are used in cable converter tuners. The single conversion type is similar to the conventional TV receiver tuner and consists essentially of an R.F. stage, mixer stage, and local oscillator. Usually some input filtering is done to help match the cable to the input device and provide some rejection to unwanted signals outside the operating channel. Further rejection to unwanted signals, such as the I.F. frequency radiated back from the I.F. amplifier, is accomplished with interstage filtering between the R.F. amplifier and the mixer, and finally an output filter matches the mixer output to the cable feeding the I.F. amplifier. For convenience, we are assuming

the desired output impedance is  $75\Omega$  and that the major I.F. amplifier frequency selectivity is determined by a block filter placed between the tuner output and I.F. amplifier input. This is consistent with modern practice using surface acoustic wave filters (SAWF's) and high gain stabilized I/C amplifiers (LM1823). Even so, as noted in more detail later, the LM1823 does provide opportunities for more filtering at the I.F. amplifier output prior to the detector stage.

Dual conversion tuners have been popular for a number of years and use first L.O. frequencies that are above the input R.F. bandwidth, avoiding problems with L.O. leakage back onto the feed cable. The second L.O. and mixer convert the high first I.F. to a Ch 3 or Ch 4 carrier for reception by the TV receiver. The addition of PLL's to control the first L.O. and descrambling networks on the R.F. output have added sufficient complexity to such converters that they are now called "set-top terminals". Also, since the scrambling techniques have become more sophisticated the signal is now frequently converted down to baseband before decoding and re-modulation on Ch 3 or Ch 4 carriers. The high first I.F. has the advantage that image signal rejection is achieved without the switchable filters necessary at the input to the single conversion tuner. However, the absence of these filters does mean that care must be exercised to avoid generation of intermodulation products that "talk back" onto the cable (up conversion of the R.F. signal has been proposed as a way to minimize intermodulation components). Another disadvantage of the dual conversion tuner shown in Figure 6 is that it typically has a very high Noise Figure, often between 14 dB to 16 dB. This is because the signal is applied directly to the first mixer which is a passive, double balanced diode mixer. As discussed in more detail later when we look at SAWF's between the tuner and the I.F. amplifier, a pre-amp in front of the mixer can improve the N.F. to 6 dB to 8 dB, especially in a baseband converter where an AGC voltage is available to help the tuner handle the input signal strength range.

Returning to the single conversion tuner, the major parameters to be considered are as follows:

- 1) Power gain
- 2) Noise Figure
- 3) Good Cross-Modulation rejection
- 4) VSWR
- 5) AGC Range
- 6) Impedance changes with AGC
- 7) Overload capability
- 8) Channel 6 beat rejection
- 9) Curve tilt (tracking)
- 10) L.O. drift and radiation

For an I.F. amplifier design, items 1), 2), 7), and 8) are the most significant, but if the tuner designer has overlooked the others we may see some problems when the tuner and I.F. amplifier are hooked together.

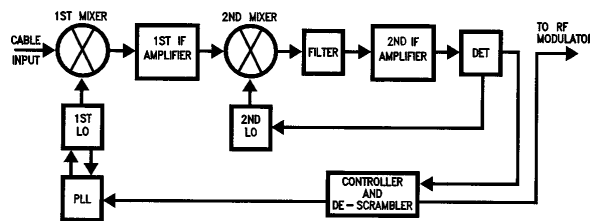

TL/H/8421-6  
**FIGURE 6. Dual Conversion Tuner**

Crossmodulation describes the condition wherein the modulation information on an adjacent channel (usually) is transferred on to the desired carrier. A typical specification is the undesired carrier level with 30% modulation needed to cause 1% modulation of the desired carrier level.

Crossmodulation is particularly likely to occur in cable systems and is usually observed as sync bars drifting through the picture. In particularly severe cases the interfering picture can actually be seen. High signal levels at the input of the mixer are a frequent cause of crossmodulation, particularly when high gain R.F. stages are used to obtain a low tuner noise figure (N.F.). But when AGC is applied the crossmodulation source often shifts to the R.F. device.

When overload occurs, (measured as the total harmonic distortion of a specified modulation frequency), the peaks of the R.F. carrier waveform become compressed and this will show up at the video detector as a smaller sync pulse amplitude (sync tip to black level). Since the AGC system operates on the sync tip level the effective result is that the black level appears to go blacker than black—i.e. some near black information will be lost and the picture will appear to have too much contrast. Alternatively if the subsequent receiver circuits have black level restoration the screen brightness increases and picture tube blooming on peak whites may occur. As overload increases there is a strong chance that vertical sync will be lost. Generally the tuner mixer device is the first stage to overload, followed by the R.F. stage. While overload is caused by very strong signal strengths and therefore may appear to be of limited concern it can also occur at weak to intermediate signal strengths because of incorrect AGC threshold settings and this will be discussed in detail later.

Channel 6 beat is a phenomenon related to mixer overload and occurs because of the choice in the U.S. of 45.75 MHz as the intermediate frequency. On channel 6, mixing of the sound and pix carriers produces a signal at 171 MHz which is then mixed with the channel 6 L.O. frequency to give 42 MHz. The I.F. sound and pix carriers can also mix with the channel 6 L.O. to produce 42 MHz. Since 42 MHz is only 170.455 kHz from the I.F. chroma subcarrier of 42.17 MHz, after detection wavy lines will appear in colored areas of the picture. Turning down the receiver color level (saturation) control will eliminate the 170 kHz pattern and identify the problem as Channel 6 beat.

Curve tilt or tracking refers to the ability of the tuner filters to track the L.O. frequency as the channel selection is changed. Problems in this area are easily identified at the video detector output (sometimes referred to as the 2nd detector) since the effect is to cause changes in the relative amplitudes of the pix, sound and chroma carriers compared to that expected from the I.F. filter response. When the detector VCO and AFT circuits of the LM1823 are aligned to 45.75 MHz, the chroma burst located on the back porch (or breezeway) portion of the horizontal blanking period in the video signal will normally be -6 dB compared to the sync pulse amplitude. If mistracking is causing a loss of high frequencies on certain channels, the burst amplitude will be lower on these channels and the picture (in severe cases) will have watery and noisy colored areas with smeared off picture detail. When the loss occurs down at the pix carrier

frequency, the burst amplitude is increased and the picture will become harsh with excessive overshoots.

Similar problems can occur on any specific channel simply due to mis-tuning or L.O. drift. In particular, as the L.O. frequency drifts high and the chroma subcarrier amplitude increases, the sound carrier also increases and chroma/sound beats will appear in the picture. In the U.S. the chroma/sound carrier beat is at 920 kHz (4.5 MHz—3.58 MHz) and appears as a herringbone pattern while the audio modulates the sound carrier. This 920 kHz beat can also be caused by detector non-linearities, and after the video detector by the detected 4.5 MHz sound intercarrier mixing with the chroma subcarrier in subsequent receiver stages. If turning down the color level control removes the 920 kHz beat then a better 4.5 MHz trap is needed at the video detector output.

These preceding comments are not meant to imply that the tuner is the root cause of all the nasty phenomenae that can be observed in the picture display. Overload, Channel 6 beat and video noise are very dependent of the tuner/I.F./AGC interaction. To understand why this is the case, we need to look at the demands that the input signal field strength puts on the system.

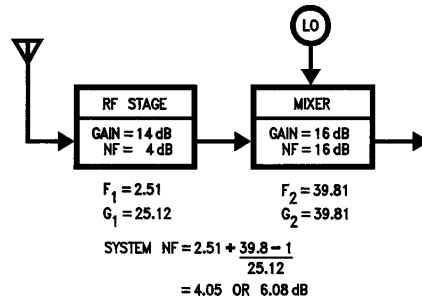

FIGURE 7. Typical Tuner Gain and Noise Figure

#### INPUT SIGNAL LEVELS

The smallest input signal is, of course, no signal or simply the noise level generated at the cable drop. To this noise level will be added the input noise of the tuner itself, giving rise to an equivalent noise input defined by the tuner noise figure (N.F.) While a specific design will have to take into account the actual operating parameters of the tuners available, we will assume a typical tuner configuration with an R.F. stage providing 14 dB gain and having a 4 dB N.F., followed by a mixer stage with 16 dB conversion gain and a 16 dB N.F. The N.F. of this combination is 6 dB, a fairly typical number, which will have the effect of increasing the actual input noise by a factor of 2. If our noise source is the cable impedance with a real part of 75Ω, at an ambient temperature of 290k, then the equivalent input noise is 2.2 uVrms (the noise contribution of any matching network or cable termination is ignored as this is included in the tuner N.F.).

Cable signal levels run from -6 dBmV to +15 dBmV with a typical system goal of maintaining a C/N ratio of at least

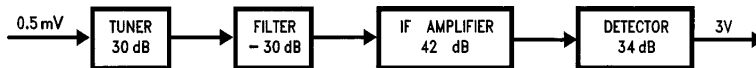

FIGURE 8. System Gain Distribution

43 dB at the cable drop to the subscriber. If a 0.5 mVrms signal is to produce the rated detector output of 3V (o-p)\* for the LM1823 then we need a total system gain of at least 75 dB. Usually the SAWF connected between the tuner output and the I.F. input will have an insertion loss of 20 dB to 30 dB so that with the 30 dB tuner gain, the I.F. amplifier/detector is required to provide the remaining 76 dB. If the tuner is simply a diode mixer with a 6–8 dB insertion loss, the gain requirement increases to 114 dB.

\* (o-p) means the detected zero carrier voltage level to the detected sync tip voltage level. The actual peak white signal to sync tip excursion at the detector will be 87.5% of this—2.63V (p-p). In the absence of a carrier, thermal noise will be present with amplitude peaks on both sides of the detected zero carrier voltage.

Fortunately the LM1823 has a high conversion gain detector (34 dB) and the I.F. amplifier gain can be set to well over 75 dB at 45.75 MHz (but we will see that some gain prior to the I.F. amplifier filter will be necessary if a good system N.F. is desired). Substantially more gain than necessary should be avoided however, even though there is plenty of AGC range in the I.F. amplifier (from 48 dB to 60 dB depending on external components). While at least 22 dB AGC capability is needed to accommodate the expected input signal strength range, if excessive system gain is used, forcing the I.F. amplifier into early gain reduction, the I.F. amplifier N.F. will begin to increase. With a diode mixer front end, the I.F. amplifier N.F. may contribute directly to the system N.F. and prevent noise-free pictures from being obtained. If a pre-amp or tuner is part of the AGC loop, gain reduction should be limited to the I.F. amplifier as much as possible, transferring gain reduction to the tuner only when the signal strength is high enough to cause distortion or cross modulation problems. The tuner gain will prevent the prior increase in I.F. amplifier N.F. from impacting the system noise performance, but excess system gain causing premature tuner gain reduction will increase the tuner N.F. and hence the system N.F.

Of great interest to us is the R.F./C/N ratio required for the detected output to be considered noise free. Actual television video S/N ratios are a little complicated by the fact that the displayed video signal does not occupy the full R.F. carrier envelope. 25% of the carrier is reserved for the synchronizing pulses and 12 1/2% is retained even under conditions of peak white modulation, for the benefit of intercarrier sound detectors. A common definition of the video S/N ratio is the ratio measured in decibels of the peak video signal amplitude to the r.m.s. noise voltage amplitude. In this context peak video refers to the voltage excursion between black and white levels (from 75% peak carrier to 12 1/2% peak carrier). With this definition in mind, it is generally accepted that the subjective effect of imperceptible noise occurs at an S/N ratio of 43 dB. Noise will become perceptible (for most viewers) at an S/N ratio around 38 dB; is clearly visible but not necessarily disturbing at 34 dB and becomes objectionable at 28 dB to 30 dB. Alternatively if we measure the signal amplitude as an r.m.s. sine wave with the same peak to peak amplitude as the R.F. carrier during the sync

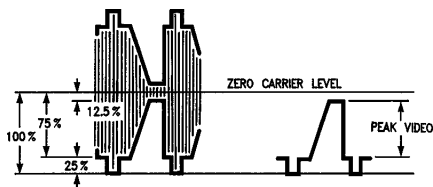

FIGURE 9. Television R.F. Modulation Envelope

pulse period, our signal is free of noise for a 47 dB C/N ratio.

If the input signal were completely noise-free (i.e. no excess noise from head-end amplifiers etc.) then the detected C/N ratio is determined by the equivalent input noise level of the tuner—2.2 uVrms for a 6 dB N.F. With a minimum signal level of 0.5 mVrms the detected C/N ratio will be 47 dB for the converter alone. When the actual signal has noise, for a cable C/N ratio of 43 dB the noise detected at the converter output is now

$$e_n = 10^{-6} \sqrt{(2.2)^2 + (3.5)^2} = 4.13 \mu V$$

This gives a detected C/N ratio of 41.6 dB, a loss of 1.3 dB compared to the original signal. For most viewers this is the just perceptible level for video noise. On the other hand, if a 14 dB N.F. converter is used, the detected C/N is 32.7 dB which is considered objectionable. A 0 dBmV signal would produce 38.7 dB C/N ratio which would be acceptable. Obviously a low N.F. is important, and any increases in N.F. should be carefully controlled to get the best picture quality possible. Figure 10 shows the change in N.F. for the LM1823 I.F. amplifier. For over 30 dB gain reduction, the N.F. is unchanged and increases by only 4 dB for the next 20 dB of gain reduction.

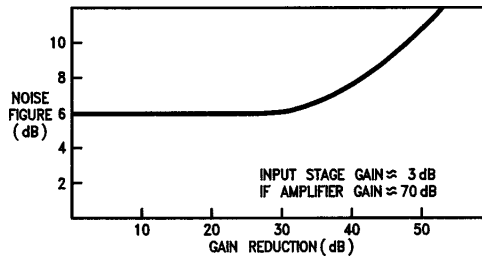

TL/H/8421-10

FIGURE 10. Increase in I.F. Amplifier N.F. with Gain Reduction

#### LM1823-GENERAL CIRCUIT DESCRIPTION

The basic arrangement of the LM1823 is shown in Figure 11. A five stage I.F. amplifier provides gain with a low impedance input stage to ensure adequate suppression of triple transit echo in SAW filters, and AGC on the three interstages. The output stage buffers the I.F. signal which is split off into two paths. A linear path takes the modulated signal to a true synchronous detector while a high gain limiter amplifier passes the I.F. carrier waveform to a second phase detector which is part of the PLL for the VCO. The PLL has an externally adjustable filter and locks the oscillator in quadrature with the incoming I.F. carrier. An in-phase component of the oscillator also drives the linear path detector to recover the signal amplitude modulation. An external DC control allows fine adjustment of the detection phase in order to optimize the detector linearity. The output from the detector is coupled back into the AGC comparator input, and is internally gated during the sync pulse period for good noise immunity and a fast response. Two AGC voltages are available; an early AGC for the I.F. amplifiers and a late, or delayed AGC for the tuner. The take-over point between the I.F. AGC and the tuner AGC is set by an external potentiometer. Also included is an AFT output for fine control of the tuner L.O. All these functions are contained in a 28-pin DIP with a pin-out designed to facilitate stable p.c.b. layouts—even with the high system gain of the LM1823 at frequencies up to 70 MHz.

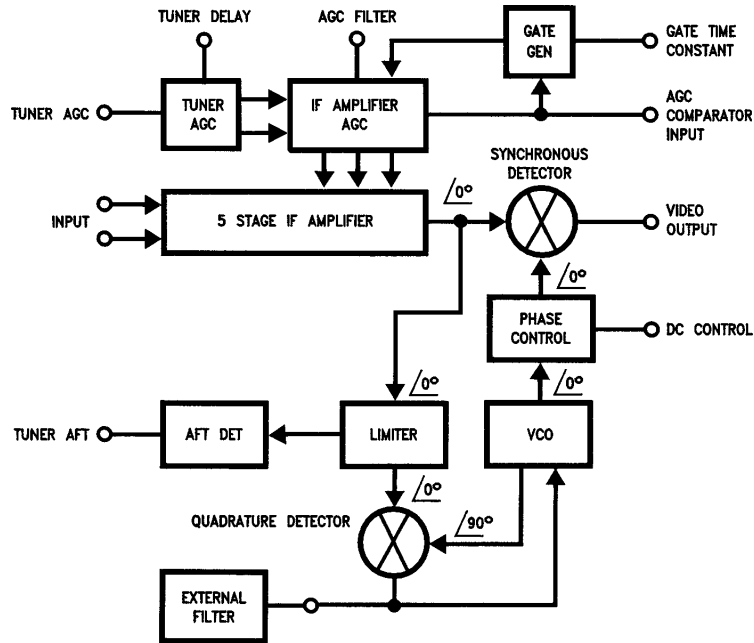

TL/H/8421-11

FIGURE 11. Block Diagram of the LM1823

**I.F. Amplifier Stages:**

The LM1823 I.F. amplifier is composed of five separate stages designed to provide high gain primarily in the frequency range of 35 MHz to 60 MHz, and gain control over a 60 dB range without overload of any stage and without introducing excess noise into the signal.

To achieve this, AGC is applied to the second through fourth stages by a control voltage that is either internally generated from the video detector output or from an externally applied bias voltage at Pin 13. AGC action starts when the voltage at Pin 13 reaches approximately 4 VDC and over 50 dB of gain reduction is obtained by the time Pin 13 voltage reaches 6.5 VDC. For a typical application, the I.F. noise figure is around 6 dB for the first 30 dB of gain reduction, and then begins to increase to above 10 dB by the time the amplifier is gain reduced over 50 dB (see Figure 10).

As mentioned earlier, the total system gain desired from the I.F. amplifier input to the video detector output needs to be

selected for a specific set of tuner parameters and I.F. filter losses. Excess gain simply means premature AGC action with possible loss of optimum video S/N ratios. To see how and where the LM1823 gain can be adjusted, we will look at each gain stage in turn.

**Input Stage:**

The input stage is a common-base differential amplifier designed to give good rejection of unwanted I.F. output and detector VCO signals that may be radiated back to the input. The low input impedance of 60Ω ensures that SAW filters are terminated sufficiently to keep the TTE better than 40 dB below the signal level, even with low impedance SAWF's. Because it is a common base stage, the input stage gain is determined by the source impedance presented to the input. An approximate expression for the gain is given by Equation (1)

$$A_v = 531 / (Z_s + 60) \tag{1}$$

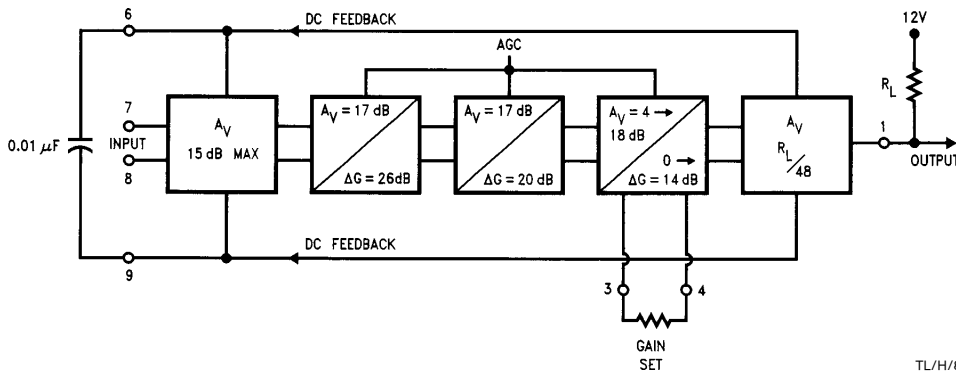

TL/H/8421-12

FIGURE 12. Gain Distribution in the I.F. Amplifier

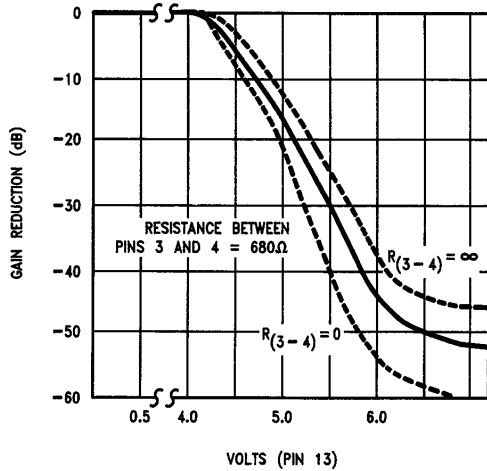

TL/H/8421-13

FIGURE 13. I.F. Amplifier Gain Reduction Characteristic

As an example, if we use a high impedance SAW filter such as the Murata SAF45 MC series with an output impedance that can be modelled as a 2.8 kΩ resistor in parallel with 8 pF capacitance, our input Zs is 345Ω (including 2 pF input stray capacitance) at 45.75 MHz. From (1), the input stage gain is 2.4 dB. If a filter is used that matches to the input stage with 60Ω, then the gain can be as much as 13 dB.

A balanced input is extremely important since the input leads Pins 6-9 are the most sensitive parts in the system to unwanted I.F. coupling. For example, if the I.F. output couples into these pins it can cause changes in the frequency response and can easily promote oscillation. A spectrum analyzer is invaluable for helping determine the system susceptibility to this phenomenon. With the input terminated by the I.F. filter (or an equivalent resistor), the I.F. amplifier output noise spectrum will show if oscillation is likely to occur.

Another signal that can appear at the input is the detector local oscillator waveform. Unlike quasi-synchronous detectors, the LM1823 has a constant (and relatively high) oscillator signal for good linear detection, even with low input signal levels. It is the balance between the input pins to the VCO radiation pick-up that will determine whether the p.c.b. layout is good enough. VCO pick-up can cause AFC skewing and asymmetrical oscillator pull-in, but probably the most serious effect is failure of the oscillator to acquire lock at weak signal levels. This is caused by the fact that the PLL

phase detector sees two input frequencies—the desired I.F. and the undesired L.O. frequency. As a result the L.O. “chases itself” and is driven outside the loop acquisition range.

Again the spectrum analyzer is a useful tool for measuring the level of VCO pick-up and the degree of improvement that any circuit modification or component relocation makes. A good layout will have symmetrical input leads placed as close together as possible, shielded input coils (where used) and external components mounted as close to the I/C as possible. The DC feedback decoupling capacitor connected between Pins 6 & 9 should be right against the pins. The pcb layout shown later, even though it uses an I/C socket, is able to keep the equivalent VCO input level to under 2 uVrms. To put this number in perspective, it is -97 dB compared to the original VCO level. For the measurements, the spectrum analyzer should be connected through a FET probe at the I.F. output, which is disconnected from the detector stage. The VCO control pin is grounded, the detector input is de-coupled with a 0.01 uF capacitor to ground, and a reference signal CW of the order of 100 uVrms is applied at the filter input.

### Second and Third Stages

These are easy to handle since they are completely self contained within the LM1823. The maximum gain is fixed at 17 dB each with 26 dB and 20 dB of gain reduction capability respectively.

### Fourth Stage

Unlike the preceding stages, the emitters of the fourth differential amplifier are available at Pins 3 & 4. An internal resistance of 1360Ω between these pins sets the minimum stage gain at 4 dB, and under these conditions (Pins 3 & 4 open) the stage does not provide significant gain reduction with AGC action. However, when an external resistor is connected between the emitters, the gain increases. For Pins 3 & 4 shorted together the gain is as much as 18 dB and the stage can provide up to 14 dB gain reduction with AGC action. Because of the way in which the total I.F. amplifier gain reduction is shared between the stages, the effective gain increase obtained by a resistor between Pins 3 & 4 occurs only for signals below the AGC threshold. After 20 dB of system gain reduction the fourth stage is fixed at 4 dB.

### Fifth Stage and I.F. Amplifier Output

The fifth and final I.F. amplifier stage has a single-ended output. There is no internal connection to the detector stage, permitting convenient isolation of the IF amplifier and detector functions. Pin 1 is also a point at which any additional signal filtering may be applied. A resistive load con-

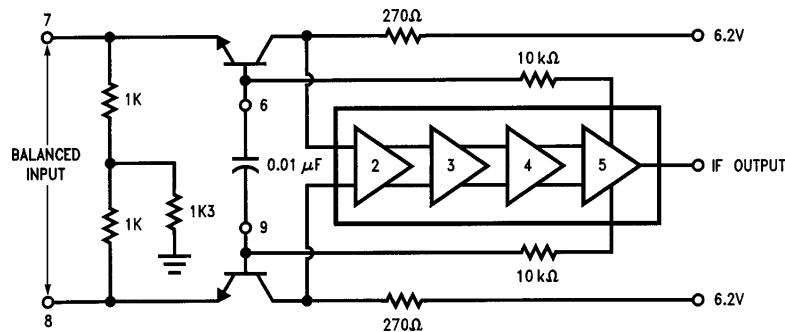

FIGURE 14. Low Impedance Common Base Input Stage

TL/H/8421-14



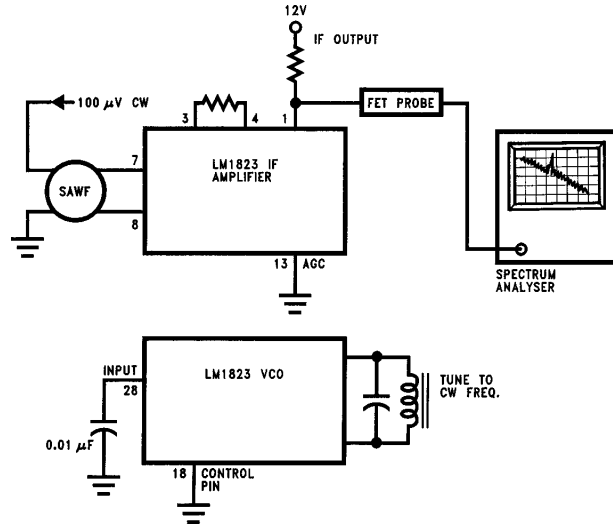

FIGURE 15. Checking the pcb for Excess VCO Pick-up

TL/H/8421-16

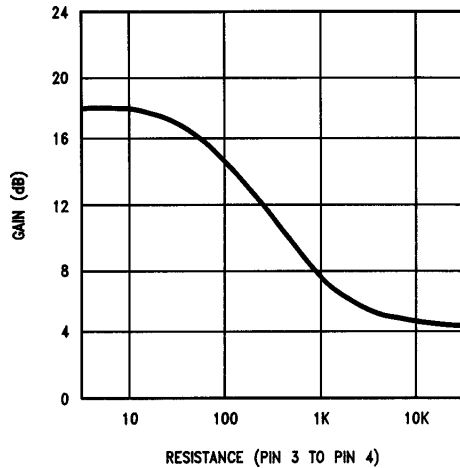

FIGURE 16. Fourth I.F. Amplifier Stage Gain with External Resistor

TL/H/8421-17

connected to the 12V power supply can be used, but the maximum value is limited in practice to less than 500Ω at intermediate frequencies because of stray p.c.b. capacitance and the loading of the detector stage input impedance of 3 kΩ. The stage gain for a total load impedance of Z is given by Equation (2)

$$AV = 1Z1/48 \quad (2)$$

The last part of the I.F. amplifier concerns the power supply input at Pin 5. This is a shunt regulated input with a nominal value of 6.3V and the I.F. amplifier current is delivered through a dropping resistor from the 12V rail supplying the remainder of the I/C. The 0.01 μF ceramic r.f. decoupling capacitor at Pin 5 should be grounded through very short

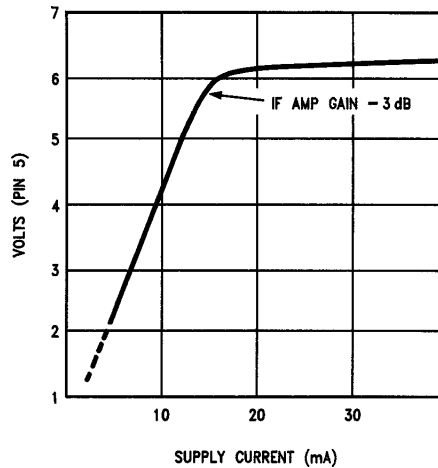

FIGURE 17. I.F. Amplifier Voltage Regulator Current Requirement

TL/H/8421-18

leads—preferably on the copper side of the p.c.b. A nominal current level into Pin 5 is 32 mA, set by a 180Ω resistor. This current should not exceed 60 mA and the minimum current is about 20 mA, below which the I.F. amplifier will start to lose gain as Pin 5 voltage drops below the regulated level.

#### SELECTING THE I.F. GAIN

Clearly the LM1823, with all the gain provided by five I.F. amplifier stages and with 34 dB detector conversion gain, has a more than adequate gain margin to provide signal sensitivity and compensate for interstage filter losses. To show how this gain may be distributed we can look at a first cut design example.

If we continue with the 30 dB gain tuner with a 6 dB N.F., using the tuner 75Ω output to mismaterminate the SAWF input will produce a very high insertion loss for the filter. This can easily be over 30 dB but before using the LM1823 gain capability to compensate for this loss, we must look at another aspect of filter insertion loss—the N.F. goes up. Previously we assumed that the tuner N.F. will dominate the system N.F.—and with a tuner amplifier N.F. of 6 dB and 30 dB gain this is indeed true. But when the I.F. amplifier and SAWF are combined the N.F. for the combination exceeds 30 dB. This degrades the system N.F. to 7 dB\* and after 50 dB of I.F. amplifier gain reduction the N.F. will be over 8 dB. Frequently this will be alright but it is instructive to consider improving the SAWF N.F. by matching the tuner output impedance to the filter or using an impedance matching pre-amp. For example, the 10 dB gain pre-amp shown in *Figure 18* has a 4 dB N.F. and reduces the filter loss to less than 20 dB. After 50 dB I.F. amplifier gain reduction, the combined N.F. is only 27 dB—for a worst case system N.F. of 6.6 dB. In a dual conversion system with a diode mixer (and already high N.F.), some gain *must* be provided prior to the SAWF.

$$*NF_{\text{system}} = NF_{\text{tuner}} + \frac{NF_{\text{IF}}}{(\text{Tuner Gain})}$$

Leaving a 10 dB gain margin over that required to raise a -6 dBmV signal to the rated detector output, the total gain requirement of the I.F. amplifier is

$$75.6 \text{ dB} - 30 \text{ dB} + 30 \text{ dB} - 34 \text{ dB} + 10 \text{ dB} = 51.6 \text{ dB}$$

(0.5 mV → 3V) (tuner) (SAWF) (detector) (gain margin)

(With a 10 dB gain impedance matching amplifier between the tuner and the SAWF, the gain requirement falls by 20 dB to 31.6 dB.) To avoid overload in the high gain tuner, we probably have to start gain reducing the tuner when the input signal reaches +10 dBmV (but certainly not before 0 dBmV in order to preserve the tuner NF) so that the I.F. AGC range requirement is approximately 26 dB. This amount of AGC range can be obtained without a resistor connected between Pins 4 & 5 putting the fourth stage gain

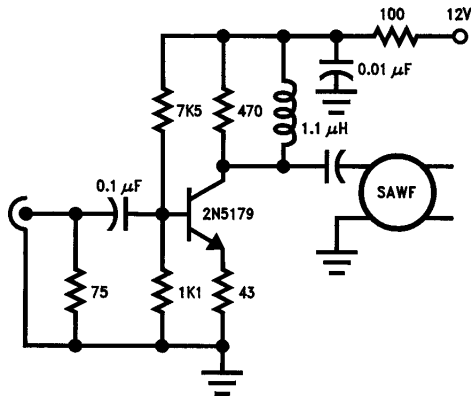

TL/H/8421-19

**FIGURE 18. Impedance Matching Pre-amplifier**

at 4 dB. The SAWF impedance sets the input stage gain at 3 dB for a total of 41 dB to the input of the final stage. A 180Ω resistor at Pin 1 gives the desired last stage gain of 11 dB, or this resistor is reduced to 50Ω and a 10 dB pad is

inserted between the I.F. amplifier output and the detector input when a pre-amp is used.

#### LM1823 VIDEO DETECTOR

The second major function of the LM1823 is the video detector stage, including the AFT/AFC detector and AGC detector/amplifier.

The video detector stage of the LM1823 has a fixed conversion gain of 34 dB—giving a 60 Vrms input level for a 3V (o-p) detected output. This input level is required for AGC action to commence and is well below the input level that can cause intermodulation or catastrophic overload.

Synchronous detection of an amplitude modulated carrier involves a source of constant amplitude CW with the same frequency as the signal carrier, and two phase detectors. One detector is operated in quadrature—i.e. the CW phase and the signal carrier phase have a 90 degree difference at the inputs to the phase detector. This detector operates solely to keep the CW source phase-locked to the signal carrier. The second phase detector has synchronous or in-phase inputs so that the detector output responds to the amplitude difference between the inputs and therefore tracks the signal amplitude modulation.

The benefits of synchronous detection over envelope detection are well known, and most modern receivers incorporate a type of detector known as a quasi-synchronous detector, which is a signal amplitude detector. The I.F. signal is amplified and stripped of modulation in order to be used as the detector CW. The disadvantages of this type of detector are the loss of linearity at very low signal inputs (corresponding to peak video modulation) and a fundamental compromise in the bandwidth of the limiter stage used to strip the modulation. To maintain ease of tuning and a relative immunity from center frequency drift caused by temperature changes and aging, the limiter bandwidth is sufficiently wide that the resulting CW is phase modulated by the information on the original I.F. carrier. Since this can generate intermodulation products, a high Q is desirable and a trade-off in ease of alignment occurs.

A less obvious problem with this type of detector is the actual static detection phase that is being regenerated. Internal I/C related phase shifts cause the limited carrier waveform applied to the detector to be more or less than 0 degrees phase-shifted with respect to the signal carrier phase. A loss in detector efficiency results, but if the limiter tuning is adjusted to compensate for this, the CW phase from the limiter will depend on the drive to the limiter. The detection phase then changes with amplitude modulation of the original I.F. carrier. The effect of this is observed primarily as differential phase in the chroma subcarrier signal and increased levels of sound buzz. Although, as discussed later, the desired phase difference between the detector CW and signal carrier is not necessarily 0 degrees, the limiter tuning cannot be used to correct the amplitude modulation detector phase—the limiter must be center tuned to avoid carrier phase shifts with modulation level.

The LM1823 overcomes these problems by providing a true synchronous detector system, which, as the block diagram shows, comprises of an internal VCO and in-phase and quadrature phase detectors. The incoming signal from the

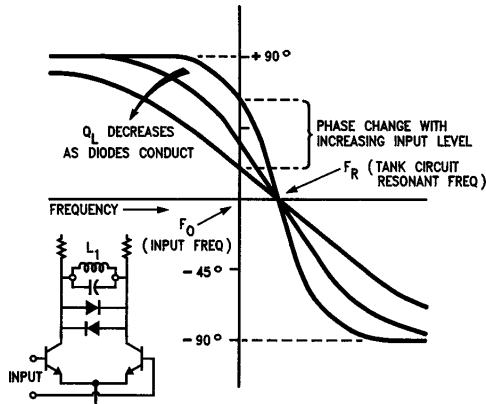

TL/H/8421-20

FIGURE 19. Limited I.F. Carrier Phase Shifts with Input Amplitude when the Limiter Tank is Mistuned

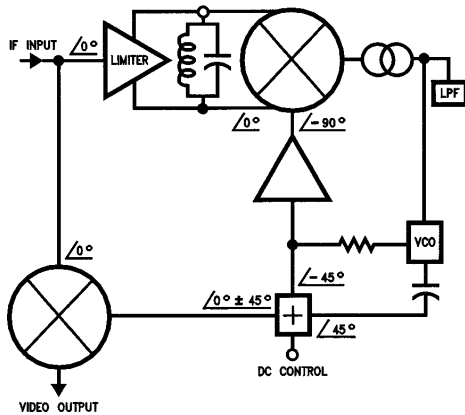

TL/H/8421-21

FIGURE 20. LM1823 Synchronous Detector and DC Controlled Detection Phase

I.F. amplifier is split into two paths. One path is through a high gain limiter stage which strips the amplitude modulation from the CW and applies it to one input of the quadrature phase detector. The other detector input is from the VCO and, once synchronized to the intermediate frequency, if the VCO phase deviates from a 90 degree relationship with the limiter CW phase, a control current is generated by the phase detector and is filtered at Pin 18 can be made to have a very narrow bandwidth. Therefore the VCO can provide a reference signal to the phase detectors with a high degree of spectral purity. The second path for the I.F. signal is directly to the in-phase detector. The VCO output passes through a DC voltage controlled phase shifter before being applied to this detector. The DC phase shifter allows precise adjustment of the synchronized VCO phase for maximum amplitude modulation detection efficiency, and compensates for any internal I/C phase shift variations. At the same time, proper center-tuning of the limiter coil is possible.

The benefits of center-tuning the limiter are clearly shown by comparing the differential chroma phase of the LM1823

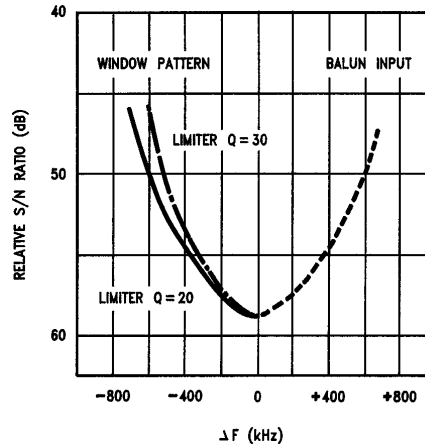

TL/H/8421-22

FIGURE 21. Relative S/N Ratio with Limiter Tuning (No SAWF)

with a conventional quasi-synchronous detector. The LM1823 can consistently produce DP'S of under 1 degree compared with up to 10 degrees for a quasi-synchronous detector. There is also a substantial improvement in the sound carrier S/N ratio. When the limiter is detuned to compensate for internal I/C phase shifts or for detection phase-lags to produce video overshoots (for a subjectively crisper picture), the S/N ratio degrades by 5 dB to 7 dB, depending on the video modulating signal.

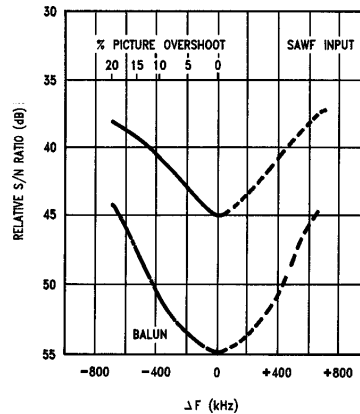

TL/H/8421-23

FIGURE 22. Effect of Limiter Retuning with SAWF

#### THE LIMITER

The limiter tuned circuit at Pins 24 and 25 is driven by a differential stage with a 6.6 kΩ internal load impedance. A small signal gain of 50 (with a tuned circuit dynamic resistance of 8 KΩ) ensures that full quadrature detector efficiency is obtained with input levels above 10 mVrms, and internal Schottky diodes limit the maximum amplitude at Pins 24 and 25 to about 500 mV (p-p). Tuning is achieved either for a peak amplitude signal measured with an F.E.T. probe (low

capacitance) at Pin 24 or Pin 25 with a 10 mVrms CW input, or by monitoring the video detector and adjusting for minimum differential chroma subcarrier phase. The latter adjustment will require a signal source modulated with a chroma/video ramp or stair-step pattern including a 20 IRE level chroma subcarrier, but does have the advantage that the adjustment can be made at strong signal levels, and does not require dis-connection of the tuner.

#### AFT/AFC CIRCUIT

The AFT phase detector is a doubly-balanced phase detector with the switching signal provided internally from the limiter stage described previously. The quadrature signal input is obtained by light external capacitive coupling from the limiter tuned circuit to the AFT tuned circuit at Pins 23 and 26. Parallel p.c.b. tracks to the limiter and AFT coils will usually provide sufficient coupling and the 1 pF capacitors on the LM1823 test circuit (see LM1823 data sheet) are shown only to illustrate the level of coupling involved. Since the AFT tuned circuit is driving an amplifier with a differential input resistance of 20 k $\Omega$ , it is able to operate close to the unloaded Q of the inductor.

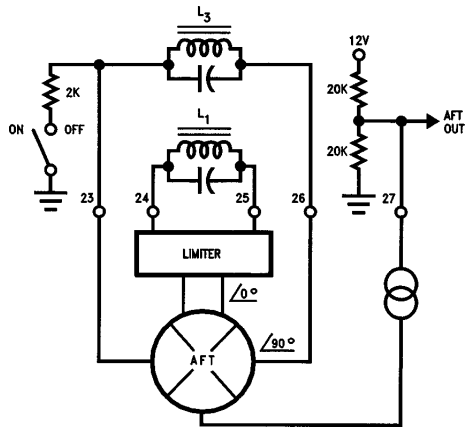

TL/H/8421-24

**FIGURE 23. AFT Circuit with pcb Coupling Between the Limiter & AFT Tuned Circuits**

The AFT output Pin 27 is driven from a current source so that the output voltage at the proper center frequency is set by an external resistive divider network. The parallel resistance of this divider will determine the voltage swing obtained for a given frequency deviation and in combination with the AFT tuned circuit Q, provides a means to adjust the AFT output slope.

Once outside the desired tuning range the AFT output voltage should stay either close to ground (I.F. frequency high) or close to the positive supply voltage (I.F. frequency low). If the voltage moves back towards the center voltage as the signal moves further away from the desired tuning range, then more coupling from the limiter tank may be needed. Grounding Pin 26 through a 2 k $\Omega$  resistor will defeat the AFT circuit for receiver fine-tuning purposes. The 2 k $\Omega$  provides isolation of the AFT switch & associated cable from the tuned circuit which has a relatively low dynamic resistance of 1.8 k $\Omega$ . Resistor values larger than 2 k $\Omega$  may prevent the circuit from being defeated, but either Pin 23 or Pin 26 can be grounded directly without damaging the I/C.

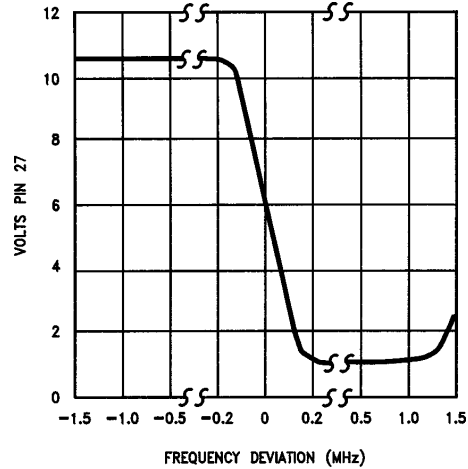

TL/H/8421-25

**FIGURE 24. AFT Circuit Output Voltage Characteristic (RLOAD at Pin 27 = 10 k $\Omega$ )**

#### THE PHASE LOCKED LOOP (PLL)

For true synchronous operation the LM1823 has an internal VCO operating at the video intermediate frequency of 45.75 MHz.

A parallel tuned circuit between Pins 19 and 20 will set the oscillator free-running center frequency and the tuned circuit dynamic resistance is loaded by an internal 1.5 k $\Omega$  resistor. Since the oscillator frequency must be controlled, a basic tradeoff exists between oscillator stability, control sensitivity and control range. To obtain a control range of over 2 MHz, the working Q of the tuned circuit should be around 15. Increasing the Q by raising the capacitive arm of the tuned circuit will improve the oscillator stability. This reduces the change in free-running frequency as a result of temperature effects etc. The control sensitivity will decrease correspondingly and there will be a reduction in the control range. The control range in the application circuit has been chosen to cover the expected deviations in the I.F. carrier that are allowed by AFT circuits. With a coil unloaded Qu of

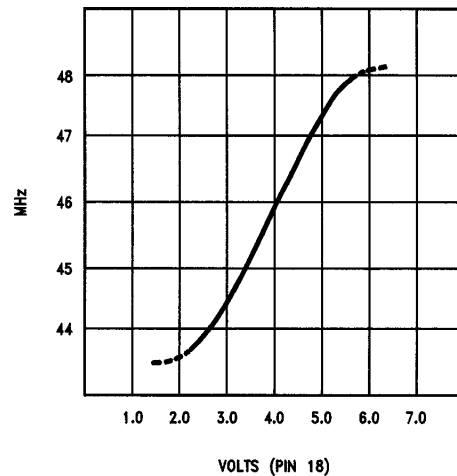

TL/H/8421-26

**FIGURE 25. VCO Control Sensitivity Characteristic**

55, and a working Q of 15, the inductance should be 0.24 uH, which tunes with 51 pF at 45.75 MHz.

The V.C.O. frequency is adjusted by injecting a 60 mVrms CW at Pin 28. If the VCO tuning ( $L_3$ ) is a long way from being correct, the detector output Pin 16 will show an AC signal of about 4V (p-p) centered around 7.5 VDC. As the oscillator is tuned toward the correct frequency the AC beat note will decrease and abruptly disappear as the oscillator locks to the carrier frequency. Final adjustment of the VCO is done by tuning  $L_3$  until the voltage at the phase detector filter Pin 18 is 4 VDC.

Oscillator control is accomplished by internally phase shifting the currents in a direct cross-coupled differential stage in response to the control voltage developed at Pin 18. Direct cross-coupling of the bases and collectors of this differential stage means that the transistors are operating in a soft-saturated mode, enabling a constant output amplitude to be obtained of about 500 mV (p-p). This output amplitude does not change with coil tuning or over the frequency control range of the oscillator. With the specified tuning components at Pins 19 and 20, the VCO sensitivity is 1.5 MHz/volt. Other general characteristics of the VCO are a negative temperature coefficient of 150 ppm/degree C, and a tendency for the oscillator control sensitivity to decrease with decreasing frequency of operation (below 10 MHz).

The VCO tuning components are mounted across the I/C package from the I.F. amplifier input. This minimizes inductive coupling and yields approximately 105 dB isolation for the I/C alone. Leads and components connected to the I.F. amplifier input will reduce the VCO isolation (as will higher operating frequencies).

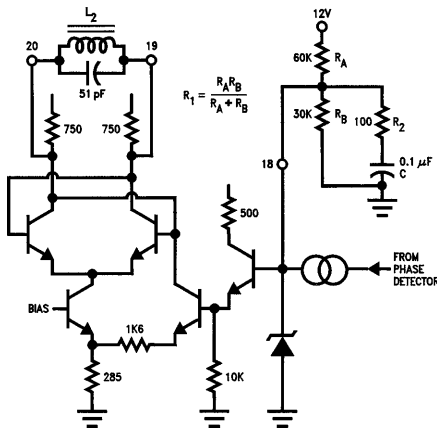

FIGURE 26. LM1823 VCO Circuit

The quadrature phase detector output is a push-pull current source so that the control voltage at Pin 18 is determined by the parallel resistance of the external divider network, which also sets the quiescent control voltage in the absence of an I.F. signal. This divider voltage should be centered at 4 VDC since the lower voltage swing for controlling the oscillator frequency is 2 VDC, and an internal clamp prevents Pin 18 increasing above 5.6 VDC. By using a 20 kΩ parallel resistance at Pin 18, the phase detector current of 7.5 uA/degree gives a phase detector sensitivity ( $\mu$ ) of 0.15 volts/degree. This parallel resistance is equivalent to R1 in the conventional filter for a 2nd order PLL. The oscillator and phase detector sensitivities given above yield a DC loop gain of 12.9 MHz/radian. For the data sheet value of 100Ω for R2,

and a filter capacitor of 0.1 uF, the loop damping factor (K) is 1.01 and the natural resonant frequency ( $\omega$ ) is 32 kHz. From this we can calculate that the loop -3 dB bandwidth is 73 kHz which is substantially less than would be practicable with a quasi-synchronous detection system, and this brings the desired benefits of low luma/sound/chroma crosstalk and freedom from quadrature distortion produced by the I.F. filter slope characteristic in the vicinity of the picture carrier frequency. Nevertheless, some signal conditions may cause wider PLL bandwidths to be used. A probable problem is incidental carrier phase modulation (ICPM).

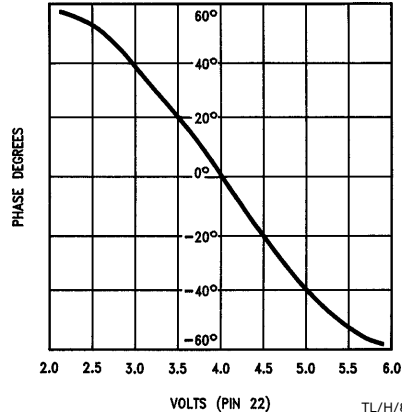

FIGURE 27. DC Controlled Phase Shifter Characteristic

This describes the shift in carrier phase as the modulation depth changes, and is particularly likely to happen where prior processing of the original carrier waveform has occurred—in distribution or conversion amplifiers employed in MATV and cable systems for example. It is also present to an extent in broadcast transmitters and if the PLL loop bandwidth is too narrow for the VCO to track this phase shift, then the ICPM is transferred to the signal modulation. This can be observed as a tint shift in color bars or a smear

PHASE LOCKED LOOP PARAMETERS		
$R_1 = R_A \parallel R_B$	VCO SENSITIVITY ( $\beta$ ) = 1.5 MHz/VOLT PHASE DETECTOR SENSITIVITY ( $\mu$ ) = 0.15V/DEGREE	
DC LOOP GAIN ( $\mu\beta$ ) = $\frac{W_c}{2\pi}$		
LOOP NATURAL FREQUENCY ( $F_n$ ) = $\frac{W_n}{2\pi}$		
$W_n = \sqrt{\frac{W_c}{C(R_1 + R_2)}}$		
LOOP DAMPING FACTOR (K) = $\frac{R_2}{2} \sqrt{\frac{C W_c}{R_1}}$		
LOOP -3dB FREQUENCY = $\frac{W_n}{2\pi} \left[ 2K^2 + 1 + \sqrt{(2K^2 + 1)^2 + 1} \right]^{1/2} \approx \frac{W_n 2K}{\pi}$ (K > 2)		
$W_c = 81 \times 10^6$ RADS/SEC $W_n = 2 \times 10^5$ RADS/SEC	$R_2 = 100\Omega$ $K = 1.01$ $F_{3dB} = 56$ KHz	$R_2 = 680\Omega$ $K = 69$ $F_{3dB} = 440$ KHz

TL/H/8421-29

in the leading edge of a color bar as the VCO belatedly attempts to track the phase change. For these types of signals it is desirable to increase the loop bandwidth to about 500 kHz—changing R2 to 680Ω is an easy fix. The loop damping factor is kept greater than 1 to avoid ringing on the phase transients. Larger loop bandwidths will increase the possibility of luma/sound/chroma crosstalk.

Once the VCO is locked in phase to the I.F. signal, the DC phase shifter Pin 22 is normally around 4 VDC for peak detector efficiency. Usually some extra phase lag will be introduced since a subjectively crisper picture is obtained if picture transients have an overshoot. Between 12% and 20% overshoot without ringing is desirable, corresponding to a 400 mV to 800 mV shift in Pin 22 voltage.

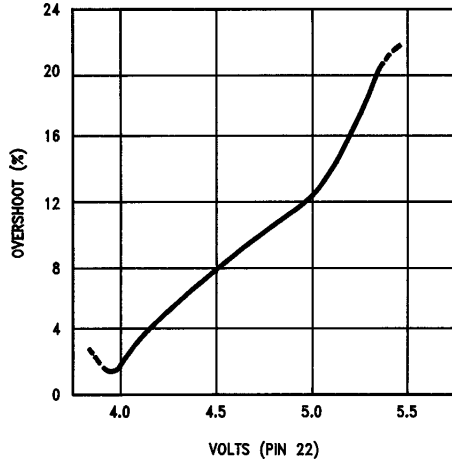

TL/H/8421-30

FIGURE 28. Signal Overshoot Produced by Carrier Detection Phase Shift

### VIDEO DETECTOR POST AMPLIFIER

The response of the video amplifier is rolled off above 9 MHz to minimize the amount of the VCO waveform and its harmonics appearing in the output at Pin 16. Typical oscillator products are 40 dB below the desired signal level.

Zener diodes are used in the video amplifiers for level shifting so that the use of PNP transistors is avoided and the detector linearity is preserved. Excellent differential gain characteristics are obtained—typically less than 3%. Pin 16 is a Darlington NPN emitter follower output. With no detector CW input signal, Pin 16 is at 7.6 VDC, representing zero carrier level which is slightly higher than peak white (by 12½%). As the CW input increases, Pin 16 voltage decreases towards black level with the sync pulses producing the most negative detector level.

The level reached by the sync tips is determined by the AGC loop threshold and if the internal AGC comparator is used (Pin 16 is directly connected to Pin 17), the sync tips will be clamped at 4 VDC. This produces a nominal detector output of 3.2V (p-p) but this is subject to variations in the Pin 16 detected zero carrier level. The resistive network shown connected between Pin 16 and Pin 17 in Figure 30 can be used to change the zero carrier level at Pin 17 for an adjustable recovered video level. For best performance the recovered video level should never be less than 1V (p-p) or greater than 4V (p-p). In suppressed sync systems, the recovered video at Pin 16 is routed to the descrambler for restoration of the sync amplitude before it is applied to Pin 17. Obviously the signal DC content must be preserved through the descrambler if proper AGC action is to be maintained.

### AGC Self Gating Comparator (LM1823)

The AGC comparator input has a low pass filter to protect the AGC loop from noise interference. Conventional detector systems often use noise gates to prevent the AGC system “backing off” on noise peaks that occur below the sync tip level. It is difficult to set the noise gate threshold close enough to the sync tip level for it to provide any benefit without risking AGC lock-out. For the LM1823 however, syn-

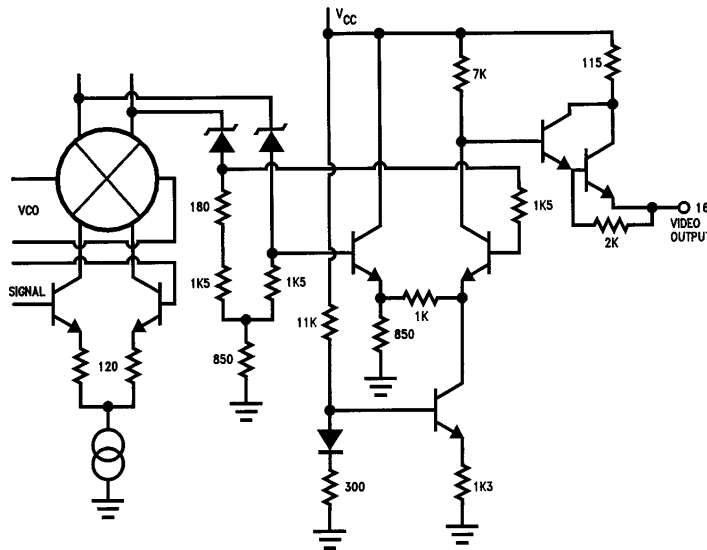

TL/H/8421-31

FIGURE 29. LM1823 Detector and Video Amplifier

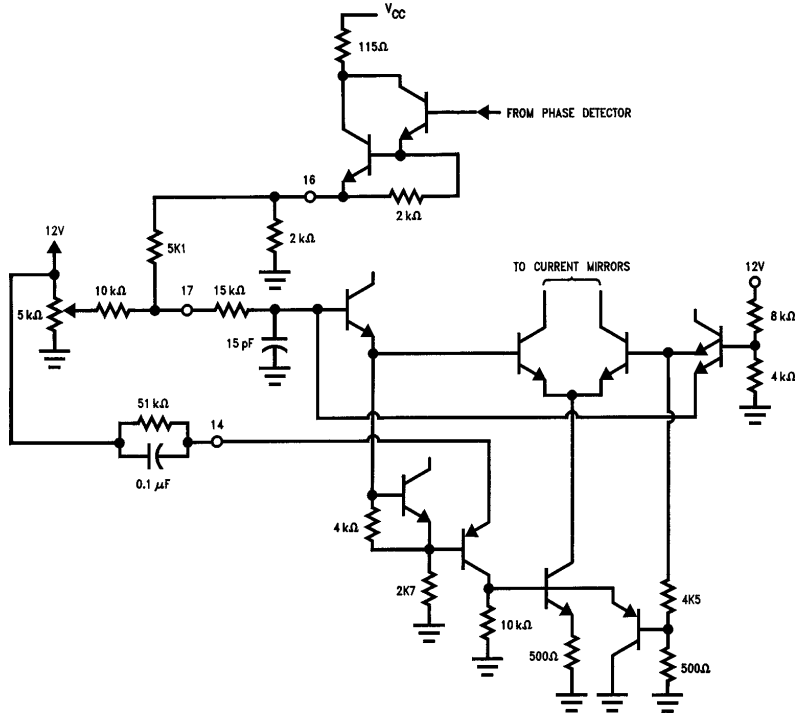

FIGURE 30. LM1823 Self Gating AGC Comparator

TL/H/8421-32

chronous detection allows the noise gate to be eliminated. Since the noise is random phase, the synchronous detector will not rectify the noise voltage and the low pass filter can average out the noise input to the comparator.

Further protection of the AGC comparator is provided by gating the comparator on only during the sync pulse period. The gate pulse is obtained from the input video waveform sync pulses at Pin 16. Essentially an emitter coupled sync stripper circuit, the slice level is set by an external time con-

stant at Pin 14. During the sync pulse period the capacitor at Pin 14 is being charged toward ground potential and the comparator is gated on. Between sync pulses the capacitor discharges towards the positive supply voltage through the resistor and the comparator is off. The sync slice level is determined by the Pin 14 RC time constant and is given in Equation (3) as the number of millivolts the slice level is above the sync tip voltage.

$$V_{SLICE} = 1/2 RC \text{ (mV)} \quad (3)$$

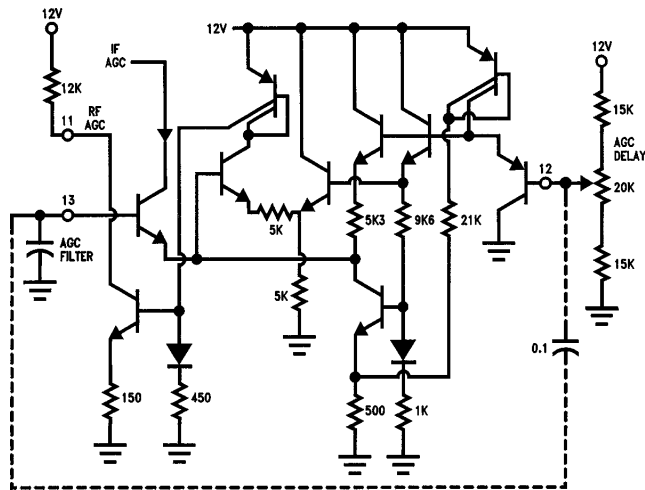

FIGURE 31. RF AGC Amplifier

TL/H/8421-33

A typical slice level for a 3V (o-p) video signal is between 100 mV and 250 mV. Different slice levels can be obtained with other capacitor values (the resistor should be left unchanged). Small capacitors will allow a faster response to a fluctuating sync tip level but also may cause the consequently deeper slice to include video overshoots.

#### RE AGC DELAY AND OUTPUT AMPLIFIER

The I.F. amplifier is at full gain below 4 VDC on Pin 13. At anywhere from 5.5 VDC to 6.5 VDC we will want to shift gain control into the R.F. stages, and this is accomplished by a delayed AGC threshold control at Pin 12. When the filter voltage on Pin 13 is 0.7V above the pre-set level on Pin 12, the R.F. AGC amplifier at Pin 11 will start to sink current.

The capacitor shown connected between Pins 12 and 13 is optional and intended to provide an increase in AGC action

for signal amplitude transients at high R.F. signal levels (tuner in gain reduction). AC changes on Pin 13 are coupled to the threshold level control allowing the I.F. amplifier to gain reduce (or increase) during the signal transient. This happens only during the signal change, so that the detected video returns more rapidly to the proper output levels. Once signal equilibrium is restored, the appropriate gain balance between the R.F. and I.F. amplifiers returns.

#### CONCLUSION

This note has described a high quality video I.F. amplifier/detector combination that can provide excellent baseband video signals. A complete schematic of the external components required in such an application is shown in *Figure 32*, with a suitable p.c.b. layout in *Figure 33*.

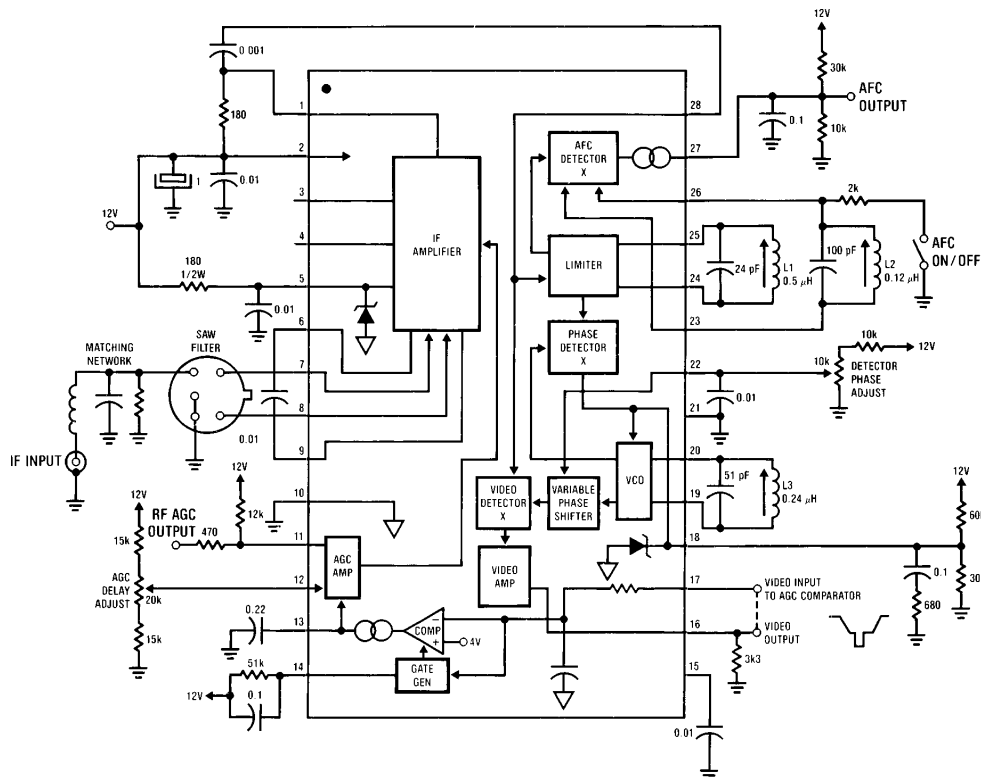

SAW Filter-MuRata SAF45MC/MA

- L1-9 1/2T } # 22 wire
  - L2-4 1/2T } on 3.16" form with
  - L3-6 1/2T } HF core, shielded
- All caps in uF unless noted

**FIGURE 32. LM1823 External Circuit Components**

TL/H/8421-34



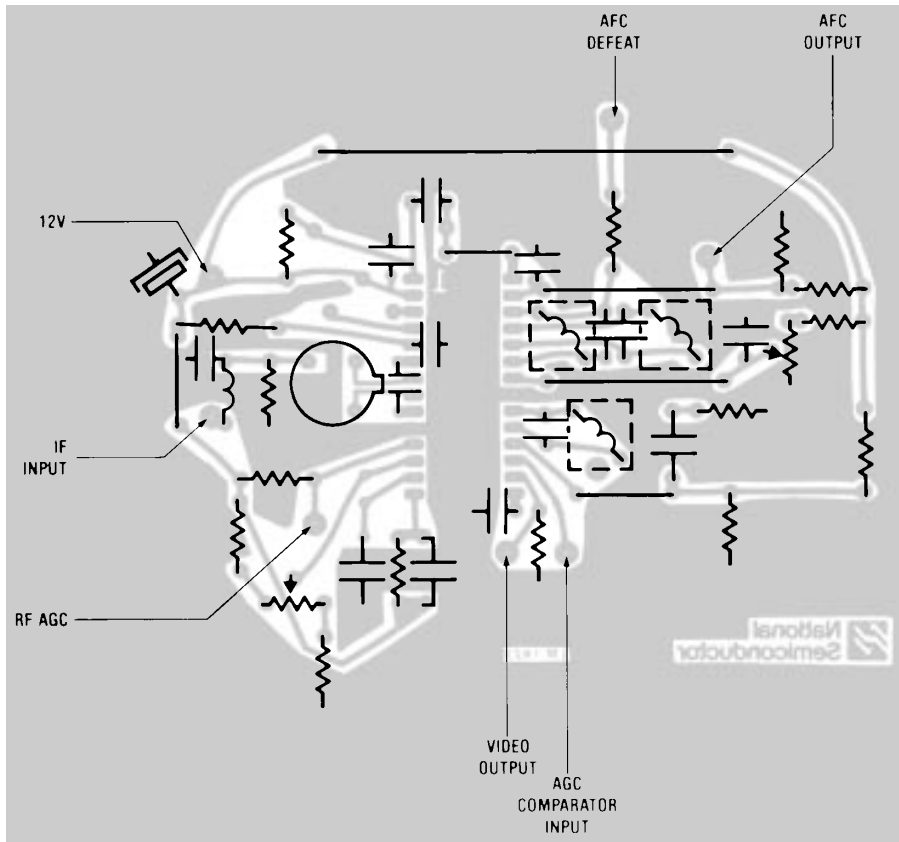

**FIGURE 33. LM1823 Printed Circuit Board Layout (Component Side)**

TL/H/8421-35

**LIFE SUPPORT POLICY**

NATIONAL'S PRODUCTS ARE NOT AUTHORIZED FOR USE AS CRITICAL COMPONENTS IN LIFE SUPPORT DEVICES OR SYSTEMS WITHOUT THE EXPRESS WRITTEN APPROVAL OF THE PRESIDENT OF NATIONAL SEMICONDUCTOR CORPORATION. As used herein:

1. Life support devices or systems are devices or systems which, (a) are intended for surgical implant into the body, or (b) support or sustain life, and whose failure to perform, when properly used in accordance with instructions for use provided in the labeling, can be reasonably expected to result in a significant injury to the user.
2. A critical component is any component of a life support device or system whose failure to perform can be reasonably expected to cause the failure of the life support device or system, or to affect its safety or effectiveness.



**National Semiconductor Corporation**  
 1111 West Bardin Road  
 Arlington, TX 76017  
 Tel: 1(800) 272-9959  
 Fax: 1(800) 737-7018

**National Semiconductor Europe**  
 Fax: (+49) 0-180-530 85 86  
 Email: onjwge@tevm2.nsc.com  
 Deutsch Tel: (+49) 0-180-530 85 85  
 English Tel: (+49) 0-180-532 78 32  
 Français Tel: (+49) 0-180-532 93 58  
 Italiano Tel: (+49) 0-180-534 16 80

**National Semiconductor Hong Kong Ltd.**  
 19th Floor, Straight Block,  
 Ocean Centre, 5 Canton Rd.  
 Tsimshatsui, Kowloon  
 Hong Kong  
 Tel: (852) 2737-1600  
 Fax: (852) 2736-9960

**National Semiconductor Japan Ltd.**  
 Tel: 81-043-299-2309  
 Fax: 81-043-299-2408

National does not assume any responsibility for use of any circuitry described, no circuit patent licenses are implied and National reserves the right at any time without notice to change said circuitry and specifications.

## IMPORTANT NOTICE

Texas Instruments Incorporated and its subsidiaries (TI) reserve the right to make corrections, modifications, enhancements, improvements, and other changes to its products and services at any time and to discontinue any product or service without notice. Customers should obtain the latest relevant information before placing orders and should verify that such information is current and complete. All products are sold subject to TI's terms and conditions of sale supplied at the time of order acknowledgment.

TI warrants performance of its hardware products to the specifications applicable at the time of sale in accordance with TI's standard warranty. Testing and other quality control techniques are used to the extent TI deems necessary to support this warranty. Except where mandated by government requirements, testing of all parameters of each product is not necessarily performed.

TI assumes no liability for applications assistance or customer product design. Customers are responsible for their products and applications using TI components. To minimize the risks associated with customer products and applications, customers should provide adequate design and operating safeguards.

TI does not warrant or represent that any license, either express or implied, is granted under any TI patent right, copyright, mask work right, or other TI intellectual property right relating to any combination, machine, or process in which TI products or services are used. Information published by TI regarding third-party products or services does not constitute a license from TI to use such products or services or a warranty or endorsement thereof. Use of such information may require a license from a third party under the patents or other intellectual property of the third party, or a license from TI under the patents or other intellectual property of TI.

Reproduction of TI information in TI data books or data sheets is permissible only if reproduction is without alteration and is accompanied by all associated warranties, conditions, limitations, and notices. Reproduction of this information with alteration is an unfair and deceptive business practice. TI is not responsible or liable for such altered documentation. Information of third parties may be subject to additional restrictions.

Resale of TI products or services with statements different from or beyond the parameters stated by TI for that product or service voids all express and any implied warranties for the associated TI product or service and is an unfair and deceptive business practice. TI is not responsible or liable for any such statements.

TI products are not authorized for use in safety-critical applications (such as life support) where a failure of the TI product would reasonably be expected to cause severe personal injury or death, unless officers of the parties have executed an agreement specifically governing such use. Buyers represent that they have all necessary expertise in the safety and regulatory ramifications of their applications, and acknowledge and agree that they are solely responsible for all legal, regulatory and safety-related requirements concerning their products and any use of TI products in such safety-critical applications, notwithstanding any applications-related information or support that may be provided by TI. Further, Buyers must fully indemnify TI and its representatives against any damages arising out of the use of TI products in such safety-critical applications.

TI products are neither designed nor intended for use in military/aerospace applications or environments unless the TI products are specifically designated by TI as military-grade or "enhanced plastic." Only products designated by TI as military-grade meet military specifications. Buyers acknowledge and agree that any such use of TI products which TI has not designated as military-grade is solely at the Buyer's risk, and that they are solely responsible for compliance with all legal and regulatory requirements in connection with such use.

TI products are neither designed nor intended for use in automotive applications or environments unless the specific TI products are designated by TI as compliant with ISO/TS 16949 requirements. Buyers acknowledge and agree that, if they use any non-designated products in automotive applications, TI will not be responsible for any failure to meet such requirements.

Following are URLs where you can obtain information on other Texas Instruments products and application solutions:

### Products

Audio	<a href="http://www.ti.com/audio">www.ti.com/audio</a>
Amplifiers	<a href="http://amplifier.ti.com">amplifier.ti.com</a>
Data Converters	<a href="http://dataconverter.ti.com">dataconverter.ti.com</a>
DLP® Products	<a href="http://www.dlp.com">www.dlp.com</a>
DSP	<a href="http://dsp.ti.com">dsp.ti.com</a>
Clocks and Timers	<a href="http://www.ti.com/clocks">www.ti.com/clocks</a>
Interface	<a href="http://interface.ti.com">interface.ti.com</a>
Logic	<a href="http://logic.ti.com">logic.ti.com</a>
Power Mgmt	<a href="http://power.ti.com">power.ti.com</a>
Microcontrollers	<a href="http://microcontroller.ti.com">microcontroller.ti.com</a>
RFID	<a href="http://www.ti-rfid.com">www.ti-rfid.com</a>
OMAP Mobile Processors	<a href="http://www.ti.com/omap">www.ti.com/omap</a>
Wireless Connectivity	<a href="http://www.ti.com/wirelessconnectivity">www.ti.com/wirelessconnectivity</a>

### Applications

Communications and Telecom	<a href="http://www.ti.com/communications">www.ti.com/communications</a>
Computers and Peripherals	<a href="http://www.ti.com/computers">www.ti.com/computers</a>
Consumer Electronics	<a href="http://www.ti.com/consumer-apps">www.ti.com/consumer-apps</a>
Energy and Lighting	<a href="http://www.ti.com/energy">www.ti.com/energy</a>
Industrial	<a href="http://www.ti.com/industrial">www.ti.com/industrial</a>
Medical	<a href="http://www.ti.com/medical">www.ti.com/medical</a>
Security	<a href="http://www.ti.com/security">www.ti.com/security</a>
Space, Avionics and Defense	<a href="http://www.ti.com/space-avionics-defense">www.ti.com/space-avionics-defense</a>
Transportation and Automotive	<a href="http://www.ti.com/automotive">www.ti.com/automotive</a>
Video and Imaging	<a href="http://www.ti.com/video">www.ti.com/video</a>

TI E2E Community Home Page

[e2e.ti.com](http://e2e.ti.com)

Mailing Address: Texas Instruments, Post Office Box 655303, Dallas, Texas 75265  
Copyright © 2011, Texas Instruments Incorporated