

TPS65218D0 ARM[®] Cortex[™]-A8/A9 SOCおよびFPGA用のパワー・マネージメント

1 デバイスの概要

1.1 特長

- スイッチングFETを内蔵した可変降圧型コンバータ×3 (DCDC1、DCDC2、DCDC3):
 - DCDC1: デフォルト1.1Vで最大1.8A
 - DCDC2: デフォルト1.1Vで最大1.8A
 - DCDC3: デフォルト1.2Vで最大1.8A
 - VIN範囲: 2.7V~5.5V
 - 可変出力電圧範囲: 0.85V~1.675V (DCDC1およびDCDC2)
 - 可変出力電圧範囲: 0.9V~3.4V (DCDC3)
 - 軽負荷電流時のパワー・セーブ・モード
 - 100%デューティ・サイクル動作による最小のドロップアウト電圧
 - ディセーブル時のアクティブな出力放電
- スイッチングFETを内蔵した可変昇降圧コンバータ×1 (DCDC4):
 - DCDC4: デフォルト3.3Vで最大1.6A
 - VIN範囲: 2.7V~5.5V
 - 可変出力電圧範囲: 1.175V~3.4V
 - ディセーブル時のアクティブな出力放電
- バッテリー・バックアップ・ドメイン用の低静止電流・高効率の降圧型コンバータ×2 (DCDC5、DCDC6)
 - DCDC5: 1Vの出力
 - DCDC6: 1.8Vの出力
 - VIN範囲: 2.2V~5.5V
 - システム電源またはコイン電池バックアップ・バッテリーから供給
- 可変汎用LDO (LDO1)
 - LDO1: デフォルト1.8Vで最大400mA
- VIN範囲: 1.8V~5.5V
- 可変出力電圧範囲: 0.9V~3.4V
- ディセーブル時のアクティブな出力放電
- 350mAの電流制限付き低電圧負荷スイッチ(LS1)
 - VIN範囲: 1.2V~3.6V
 - 1.35V時のスイッチ・インピーダンス: 110mΩ (最大値)
- 電流制限を100mAまたは500mAに選択できる5V負荷スイッチ(LS2)
 - 3Vから5.5VまでのVIN範囲
 - 5V時のスイッチ・インピーダンス: 500mΩ (最大値)
- 電流制限を100mAまたは500mAに選択できる高電圧負荷スイッチ(LS3)
 - VIN範囲: 1.8V~10V
 - スイッチ・インピーダンス: 500mΩ (最大値)
- スーパーバイザ機能モニタを内蔵したスーパーバイザ
 - DCDC1、DCDC2 ±4%精度
 - DCDC3、DCDC4 ±5%精度
 - LDO1 ±5%精度
- 保護、診断、制御:
 - 低電圧誤動作防止(UVLO)
 - 常時オンのプッシュボタン・モニタ
 - 過熱警告とシャットダウン
 - バックアップ電源およびメイン電源用の個別のパワー・グッド出力
 - I²Cインターフェイス(アドレスは0x24) (400kHz時のI²Cの動作については、[タイミング要件](#)を参照)

1.2 アプリケーション

- 産業用オートメーション
- 電子POS (ePOS)
- 試験/測定機器
- パーソナル・ナビゲーション
- 産業用通信
- バックプレーンI/O
- ネットワーク接続型の産業用ドライブ

1.3 概要

TPS65218D0はシングル・チップのパワー・マネージメントIC (PMIC)であり、携帯機器(リチウムイオン電池)と据置き機器(5Vアダプタ)の両方で使用されるAM335xおよびAM438xラインのプロセッサのサポートに特化して設計されています。このデバイスは、-40°C~+105°Cの温度範囲で動作することが特長で、各種の産業用アプリケーションに適しています。



TPS65218D0は、AM438xプロセッサのすべての機能についてパワー・マネージメントを行うよう、特化して設計されています。DCDC1からDCDC4までの各DC/DCコンバータは、それぞれコア、MPU、DDRメモリ、3.3VアナログおよびI/Oの給電用です。LDO1は、プロセッサに1.8VのアナログおよびI/O電源を供給します。GPIO1およびGPO2はメモリ・リセットを行い、GPIO3は、DCDC1およびDCDC2コンバータのウォーム・リセットを行います(335xのみ)。ユーザーは、I²Cインターフェイスによりすべての電圧レギュレータ、負荷スイッチ、GPIOをイネーブル/ディセーブルできます。さらに、UVLOおよびスーパーバイザ電圧スレッシュホールド、電源オン・シーケンス、電源オフ・シーケンスもI²Cでプログラムできます。過熱、過電流、低電圧に対する割り込みも監視できます。スーパーバイザがDCDC1～DCDC4、LDO1を監視します。スーパーバイザには2つの設定があり、1つは標準的な低電圧許容範囲(STRICT = 0b)、もう1つは厳格な低電圧および過電圧の許容範囲(STRICT = 1b)です。パワー・グッド信号により、5Vレギュレータが正しくレギュレートしていることが示されます。

3つのヒステリシス降圧型コンバータは、プロセッサのコア、MPU、DDR_xメモリへの給電用です。各コンバータのデフォルトの出力電圧は、I²Cインターフェイスを介して調整可能です。DCDC1およびDCDC2は動的電圧スケーリングにより、プロセッサのあらゆる動作点で電力を供給できます。また、DCDC1およびDCDC2ではスルーレートをプログラミングできるため、プロセッサ・コンポーネントの保護に役立ちます。DCDC3は、プロセッサがスリープ・モードの間も、DDR_xメモリへの電力を維持するために給電され続けます。システム電源の停電またはディセーブル時には、バックアップ電源によりプロセッサのタンパ、RTC、または両方のドメイン用に2つの降圧型コンバータが提供されます。システム電源とコイン電池/バッテリーの両方をPMICに接続した場合、コイン電池/バッテリーからは給電されません。個別のパワー・グッド信号がバックアップ・コンバータを監視します。バッテリー・バックアップ・モニタによって、コイン電池/バッテリーの電力レベルが明らかになります。

TPS65218D0デバイスは、48ピンのVQFNパッケージ(6mm×6mm、0.4mmピッチ)で供給されます。

製品情報⁽¹⁾

型番	パッケージ	本体サイズ(公称)
TPS65218D0	VQFN (48) ⁽²⁾	6.00mm×6.00mm
	HTQFP (48)	7.00mm×7.00mm

- (1) 利用可能なすべてのパッケージについては、このデータシートの末尾にある注文情報を参照してください。
 (2) VQFNパッケージは開発中。

Table of Contents

1	デバイスの概要	1	5.4	Device Functional Modes	47
1.1	特長	1	5.5	Programming	48
1.2	アプリケーション	1	5.6	Register Maps	50
1.3	概要	1	6	Application and Implementation	92
1.4	概略回路図	3	6.1	Application Information	92
2	改訂履歴	4	6.2	Typical Application	94
3	Pin Configuration and Functions	5	7	Power Supply Recommendations	98
3.1	Pin Functions	5	8	Layout	98
4	Specifications	7	8.1	Layout Guidelines	98
4.1	Absolute Maximum Ratings	7	8.2	Layout Example	98
4.2	ESD Ratings	7	9	デバイスおよびドキュメントのサポート	100
4.3	Recommended Operating Conditions	8	9.1	デバイス・サポート	100
4.4	Thermal Information	8	9.2	ドキュメントのサポート	100
4.5	Electrical Characteristics	9	9.3	ドキュメントの更新通知を受け取る方法	100
4.6	Timing Requirements	18	9.4	Community Resources	100
4.7	Typical Characteristics	20	9.5	商標	100
5	Detailed Description	21	9.6	静電気放電に関する注意事項	101
5.1	Overview	21	9.7	Glossary	101
5.2	Functional Block Diagram	22	10	メカニカル、パッケージ、および注文情報	101
5.3	Feature Description	23			

2 改訂履歴

資料番号末尾の英字は改訂を表しています。その改訂履歴は英語版に準じています。

Revision A (July 2018) から Revision B に変更		Page
•	新規アプリケーション 追加	1
•	Added updates to Description column in the Pin Functions table	5
•	Added table note	19
•	Changed the location of Backup Supply Power-Good section	28
•	Added Programming section	48

2017年12月発行のものから更新		Page
•	Changed the maximum value for the input voltage for the LS3 parameter from 100 V to 10 V in the <i>Recommended Operating Conditions</i> table	8
•	Added the <i>List of Recommended Capacitors</i> table in the <i>Output Capacitor Selection</i> section	96

3 Pin Configuration and Functions

Figure 3-1 shows the 48-pin RSL Plastic Quad Flatpack No-Lead. Figure 3-2 shows the 48-pin PHP PowerPAD™ Plastic Quad Flatpack.

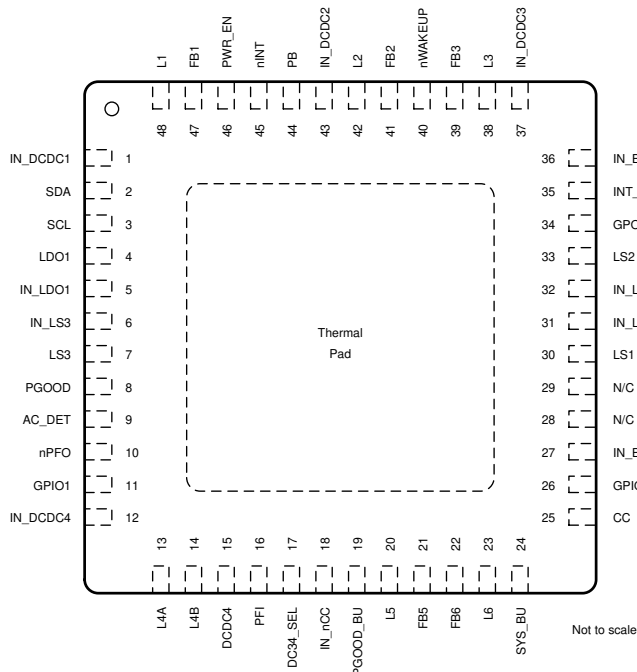

Figure 3-1. 48-Pin RSL VQFN With Exposed Thermal Pad (Top View, 6 mm × 6 mm × 1 mm With 0.4-mm Pitch)

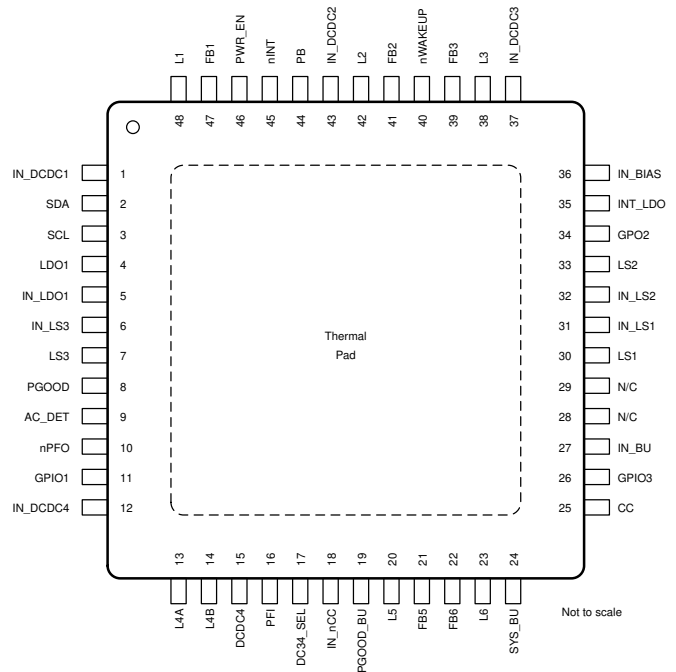

Figure 3-2. 48-Pin PHP PowerPAD™ HTQFP (Top View, 7 mm × 7 mm × 1 mm With 0.5-mm Pitch)

3.1 Pin Functions

Pin Functions

PIN		TYPE	DESCRIPTION
NO.	NAME		
1	IN_DCDC1	P	Input supply pin for DCDC1.
2	SDA	I/O	Data line for the I ² C interface. Connect to pullup resistor.
3	SCL	I	Clock input for the I ² C interface. Connect to pullup resistor.
4	LDO1	O	Output voltage pin for LDO1. Connect to capacitor.
5	IN_LDO1	P	Input supply pin for LDO1.
6	IN_LS3	P	Input supply pin for load switch 3.
7	LS3	O	Output voltage pin for load switch 3. Connect to capacitor.
8	PGOOD	O	Power-good output (configured as open drain). Pulled low when either DCDC1-4 or LDO1 are out of regulation. Load switches and DCDC5-6 do not affect PGOOD pin.
9	AC_DET	I	AC monitor input and enable for DCDC1-4, LDO1 and load switches. See Section 5.4.1 for details. Tie pin to IN_BIAS if not used.
10	nPFO	O	Power-fail comparator output, deglitched (open drain). Pin is pulled low when PFI input is below power-fail threshold.
11	GPIO1	I/O	Pin configured as DDR reset-input (driving GPO2) or as general-purpose, open-drain output. See Section 5.3.1.14 for more information.
12	IN_DCDC4	P	Input supply pin for DCDC4.
13	L4A	P	Switch pin for DCDC4. Connect to inductor.
14	L4B	P	Switch pin for DCDC4. Connect to inductor.
15	DCDC4	P	Output voltage pin for DCDC4. Connect to capacitor.

Pin Functions (continued)

PIN		TYPE	DESCRIPTION
NO.	NAME		
16	PFI	I	Power-fail comparator input. Connect to resistor divider.
17	DC34_SEL	I	Power-up default selection pin for DCDC3 or DCDC4. Power-up default is programmed by a resistor connected to ground. See Section 5.3.1.13 for resistor options.
18	IN_nCC	O	Output pin indicates if DCDC5 and DCDC6 are powered from main supply (IN_BU) or coin-cell battery (CC). Pin is push-pull output. Pulled low when PMIC is powered from coin cell battery. Pulled high when PMIC is powered from main supply (IN_BU).
19	PGOOD_BU	O	Power-good, push-pull output for DCDC5 and DCDC6. Pulled low when either DCDC5 or DCDC6 is out of regulation. Pulled high (to DCDC6 output voltage) when both rails are in regulation.
20	L5	P	Switch pin for DCDC5. Connect to inductor.
21	FB5	I	Feedback voltage pin for DCDC5. Connect to output capacitor.
22	FB6	I	Feedback voltage pin for DCDC6. Connect to output capacitor.
23	L6	P	Switch pin for DCDC6. Connect to inductor.
24	SYS_BU	P	System voltage pin for battery-backup supply power path. Connect to 1- μ F capacitor. Connecting any external load to this pin is not recommended.
25	CC	P	Coin cell battery input. Serves as the supply to DCDC5 and DCDC6 if no voltage is applied to IN_BU. Tie this pin to ground if it is not in use.
26	GPIO3	I/O	Pin can be configured as warm reset (negative edge) for DCDC1/2 or as a general-purpose, open-drain output. See Section 5.3.1.14 for more details.
27	IN_BU	P	Default input supply pin for battery backup supplies (DCDC5 and DCDC6).
28	N/C	—	No connect. Leave pin floating.
29	N/C		
30	LS1	O	Output voltage pin for load switch 1. Connect to capacitor.
31	IN_LS1	P	Input supply pin for load switch 1.
32	IN_LS2	P	Input supply pin for load switch 2.
33	LS2	O	Output voltage pin for load switch 2. Connect to capacitor.
34	GPO2	O	Pin configured as DDR reset signal (controlled by GPIO1) or as general-purpose output. Buffer can be configured as push-pull or open-drain.
35	INT_LDO	P	Internal bias voltage. Connect to a 1- μ F capacitor. TI does not recommended connecting any external load to this pin.
36	IN_BIAS	P	Input supply pin for reference system.
37	IN_DCDC3	P	Input supply pin for DCDC3.
38	L3	P	Switch pin for DCDC3. Connect to inductor.
39	FB3	I	Feedback voltage pin for DCDC3. Connect to output capacitor.
40	nWAKEUP	O	Signal to SOC to indicate a power on event (active low, open-drain output).
41	FB2	I	Feedback voltage pin for DCDC2. Connect to output capacitor.
42	L2	P	Switch pin for DCDC2. Connect to inductor.
43	IN_DCDC2	P	Input supply pin for DCDC2.
44	PB	I	Push-button monitor input. Typically connected to a momentary switch to ground (active low). See Section 5.4.1 for details.
45	nINT	O	Interrupt output (active low, open drain). Pin is pulled low if an interrupt bit is set. The pin returns to Hi-Z state after the bit causing the interrupt has been read. Interrupts can be masked.
46	PWR_EN	I	Power enable input for DCDC1-4, LDO1 and load switches. See Section 5.4.1 for details.
47	FB1	I	Feedback voltage pin for DCDC1. Connect to output capacitor.
48	L1	P	Switch pin for DCDC1. Connect to inductor.
—	Thermal Pad	P	Power ground and thermal relief. Connect to ground plane.

4 Specifications

4.1 Absolute Maximum Ratings

Operating under free-air temperature range (unless otherwise noted)⁽¹⁾

		MIN	MAX	UNIT
Supply voltage	IN_BIAS, IN_LDO1, IN_LS2, IN_DCDC1, IN_DCDC2, IN_DCDC3, IN_DCDC4	-0.3	7	V
	IN_LS1, CC	-0.3	3.6	
	IN_LS3	-0.3	11.2	
	IN_BU	-0.3	5.8	
Input voltage	All pins unless specified separately	-0.3	7	V
Output voltage	All pins unless specified separately	-0.3	7	V
Source or sink current	GPO2		6	mA
	PGOOD_BU, IN_nCC		1	
Sink current	PGOOD, nWAKEUP, nINT, nPFO, SDA, GPIO1, GPIO3		6	mA
T _A	Operating ambient temperature	-40	105	°C
T _J	Junction temperature	-40	125	°C
T _{stg}	Storage temperature	-65	150	°C

(1) Stresses beyond those listed under *Absolute Maximum Ratings* may cause permanent damage to the device. These are stress ratings only and functional operation of the device at these or any other conditions beyond those indicated under *Recommended Operating Conditions* is not implied. Exposure to absolute-maximum-rated conditions for extended periods may affect device reliability.

4.2 ESD Ratings

		VALUE	UNIT
V _(ESD)	Electrostatic discharge	Human-body model (HBM), per ANSI/ESDA/JEDEC JS-001 ⁽¹⁾	±2000
		Charged-device model (CDM), per JEDEC specification JESD22-C101 ⁽²⁾	±500

(1) JEDEC document JEP155 states that 500-V HBM allows safe manufacturing with a standard ESD control process.

(2) JEDEC document JEP157 states that 250-V CDM allows safe manufacturing with a standard ESD control process.

4.3 Recommended Operating Conditions

over operating free-air temperature range (unless otherwise noted)

		MIN	NOM	MAX	UNIT
Supply voltage, IN_BIAS		2.7		5.5	V
Input voltage for DCDC1, DCDC2, DCDC3, DCDC4		2.7		5.5	V
Supply voltage, IN_BU		2.2		5.5	V
Supply voltage, CC		2.2		3.3	V
Input voltage for LDO1		1.8		5.5	V
Input voltage for LS1		1.2		3.6	V
Input voltage for LS2		3		5.5	V
Input voltage for LS3		1.8		10	V
Output voltage for DCDC1		0.85		1.675	V
Output voltage for DCDC2		0.85		1.675	V
Output voltage for DCDC3		0.9		3.4	V
Output voltage for DCDC4		1.175		3.4	V
Output voltage for DCDC5			1		V
Output voltage for DCDC6			1.8		V
Output voltage for LDO1		0.9		3.4	V
Output current for DCDC1, DCDC2, DCDC3		0		1.8	A
Output current for DCDC4	VIN_DCDC4 = 2.8 V			1	A
	VIN_DCDC4 = 3.6 V			1.3	
	VIN_DCDC4 = 5 V			1.6	
Output current for DCDC5, DCDC6		0		25	mA
Output current for LDO1		0		400	mA
Output current for LS1		0		300	mA
Output current for LS2		0		920	mA
Output current for LS3	VIN_LS3 > 2.3 V	0		900	mA
	VIN_LS3 ≤ 2.3 V	0		475	

4.4 Thermal Information

THERMAL METRIC ⁽¹⁾		TPS65218D0		UNIT
		RSL (VQFN)	PHP (HTQFP)	
		16 PINS	16 PINS	
R _{θJC(top)}	Junction-to-case (top)	17.2	13.3	°C/W
R _{θJB}	Junction-to-board	5.8	7.9	°C/W
R _{θJA}	Thermal resistance, junction to ambient. JEDEC 4-layer, high-K board.	30.6	26.7	°C/W
Ψ _{JT}	Junction-to-package top	0.2	0.3	°C/W
Ψ _{JB}	Junction-to-board	5.6	7.8	°C/W
R _{θJC(bot)}	Junction-to-case (bottom)	1.5	0.7	°C/W

(1) For more information about traditional and new thermal metrics, see the [Semiconductor and IC Package Thermal Metrics](#) application report.

4.5 Electrical Characteristics

over operating free-air temperature range (unless otherwise noted)

PARAMETER		TEST CONDITIONS	MIN	TYP	MAX	UNIT
INPUT VOLTAGE AND CURRENTS						
V_{IN_BIAS}	Input supply voltage range	Normal operation	2.7		5.5	V
		EEPROM programming	4.5		5.5	
V_{UVLO}	Hysteresis	Supply rising	UVLOHYS = 0b	200		mV
			UVLOHYS = 1b	400		mV
	Deglitch time			5		ms
I_{OFF}	OFF state current, total current into IN_BIAS, IN_DCDCx, IN_LDO1, IN_LSx, IN_BU	$V_{IN} = 3.6$ V; All rails disabled. $T_J = 0^\circ\text{C}$ to 85°C		5		μA
$I_{SUSPEND}$	SUSPEND current, total current into IN_BIAS, IN_DCDCx, IN_LDO1, IN_LSx, IN_BU	$V_{IN} = 3.6$ V; DCDC3 enabled, low-power mode, no load. All other rails disabled. $T_J = 0^\circ\text{C}$ to 105°C		220		μA
SYS_BU						
V_{SYS_BU}	SYS_BU voltage range	Powered from V_{IN_BU} or V_{CC}	2.2		5.5	V
C_{SYS_BU}	Recommended SYS_BU capacitor	Ceramic, X5R or X7R, see Table 6-3		1		μF
	Tolerance	Ceramic, X5R or X7R, rated voltage ≥ 6.3 V	-20%		20%	
INT_LDO						
V_{INT_LDO}	Output voltage			2.5		V
	DC accuracy	$I_{OUT} < 10$ mA	-2%		2%	
I_{OUT}	Output current range	Maximum allowable external load	0		10	mA
I_{LIMIT}	Short circuit current limit	Output shorted to GND		23		mA
t_{HOLD}	Hold-up time	Measured from $V_{INT_LDO} = 2.3$ V to $V_{INT_LDO} = 1.8$ V All rails enabled before power off, IN_BIAS tied to IN_DCDC1-4, IN_LDO1 $V_{IN_BIAS} = 2.8$ V to 0 V in < 5 μs No external load on INT_LDO $C_{INT_LDO} = 1$ μF , see Table 6-3	150			ms
C_{OUT}	Nominal output capacitor value	Ceramic, X5R or X7R, see Table 6-3	0.1	1	22	μF
	Tolerance	Ceramic, X5R or X7R, rated voltage ≥ 6.3 V	-20%		20%	
DCDC1 (1.1-V BUCK)						
V_{IN_DCDC1}	Input voltage range	$V_{IN_BIAS} > V_{UVLO}$	2.7		5.5	V
V_{DCDC1}	Output voltage range	Adjustable through I ² C	0.85		1.675	V
	DC accuracy	$2.7 \text{ V} \leq V_{IN} \leq 5.5 \text{ V}$; $0 \text{ A} \leq I_{OUT} \leq 1.8 \text{ A}$	-2%		2%	
	Dynamic accuracy	In respect to nominal output voltage $I_{OUT} = 50$ mA to 450 mA in < 1 μs $C_{OUT} \geq 10$ μF , over full input voltage range	-2.5%		2.5%	
I_{OUT}	Continuous output current	$V_{IN_DCDC1} > 2.7$ V			1.8	A
I_Q	Quiescent current	Total current from IN_DCDC1 pin; Device not switching, no load		25	50	μA
$R_{DS(ON)}$	High-side FET on resistance	$V_{IN_DCDC1} = 3.6$ V		230	355	m Ω
	Low-side FET on resistance	$V_{IN_DCDC1} = 3.6$ V		90	145	
I_{LIMIT}	High-side current limit	$V_{IN_DCDC1} = 3.6$ V		2.8		A
	Low-side current limit	$V_{IN_DCDC1} = 3.6$ V		3.1		

Electrical Characteristics (continued)

over operating free-air temperature range (unless otherwise noted)

PARAMETER		TEST CONDITIONS		MIN	TYP	MAX	UNIT
V _{PG}	Power-good threshold	V _{OUT} falling	STRICT = 0b	88.5%	90%	91.5%	
			STRICT = 1b	96%	96.5%	97%	
	Hysteresis	V _{OUT} rising	STRICT = 0b	3.8%	4.1%	4.4%	
			STRICT = 1b		0.25%		
	Deglitch	V _{OUT} falling	STRICT = 0b		1		ms
			STRICT = 1b		50		μs
		V _{OUT} rising	STRICT = 0b		10		μs
			STRICT = 1b		10		μs
Time-out	Occurs at enable of DCDC1 and after DCDC1 register write (register 0x16)				5		ms
V _{OV}	Overvoltage detection threshold	V _{OUT} rising, STRICT = 1b		103%	103.5%	104%	
	Hysteresis	V _{OUT} falling, STRICT = 1b			0.25%		
	Deglitch	V _{OUT} rising, STRICT = 1b			50		μs
I _{INRUSH}	Inrush current	V _{IN_DCDC1} = 3.6 V; C _{OUT} = 10 μF to 100 μF				500	mA
R _{DIS}	Discharge resistor			150	250	350	Ω
L	Nominal inductor value	See Table 6-2		1	1.5	2.2	μH
	Tolerance			-30%		30%	
C _{OUT}	Output capacitance value	Ceramic, X5R or X7R, see Table 6-3		10	22	100 ⁽¹⁾	μF
DCDC2 (1.1-V BUCK)							
V _{IN_DCDC2}	Input voltage range	V _{IN_BIAS} > V _{UVLO}		2.7		5.5	V
V _{DCDC2}	Output voltage range	Adjustable through I ² C		0.85		1.675	V
	DC accuracy	2.7 V ≤ V _{IN} ≤ 5.5 V; 0 A ≤ I _{OUT} ≤ 1.8 A		-2%		2%	
	Dynamic accuracy	In respect to nominal output voltage I _{OUT} = 50 mA to 450 mA in < 1 μs C _{OUT} ≥ 10 μF, over full input voltage range		-2.5%		2.5%	
I _{OUT}	Continuous output current	V _{IN_DCDC2} > 2.7 V				1.8	A
I _Q	Quiescent current	Total current from I _{N_DCDC2} pin; Device not switching, no load			25	50	μA
R _{DS(ON)}	High-side FET on resistance	V _{IN_DCDC2} = 3.6 V			230	355	mΩ
	Low-side FET on resistance	V _{IN_DCDC2} = 3.6 V			90	145	
I _{LIMIT}	High-side current limit	V _{IN_DCDC2} = 3.6 V			2.8		A
	Low-side current limit	V _{IN_DCDC2} = 3.6 V			3.1		
V _{PG}	Power-good threshold	V _{OUT} falling	STRICT = 0b	88.5%	90%	91.5%	
			STRICT = 1b	96%	96.5%	97%	
	Hysteresis	V _{OUT} rising	STRICT = 0b	3.8%	4.1%	4.4%	
			STRICT = 1b		0.25%		
	Deglitch	V _{OUT} falling	STRICT = 0b		1		ms
			STRICT = 1b		50		μs
		V _{OUT} rising	STRICT = 0b		10		μs
			STRICT = 1b		10		μs
Time-out	Occurs at enable of DCDC2 and after DCDC2 register write (register 0x17)				5		ms
V _{OV}	Overvoltage detection threshold	V _{OUT} rising, STRICT = 1b		103%	103.5%	104%	
	Hysteresis	V _{OUT} falling, STRICT = 1b			0.25%		
	Deglitch	V _{OUT} rising, STRICT = 1b			50		μs
I _{INRUSH}	Inrush current	V _{IN_DCDC2} = 3.6 V; C _{OUT} = 10 μF to 100 μF				500	mA
R _{DIS}	Discharge resistor			150	250	350	Ω

(1) 500-μF of remote capacitance can be supported for DCDC1/2.

Electrical Characteristics (continued)

over operating free-air temperature range (unless otherwise noted)

PARAMETER		TEST CONDITIONS	MIN	TYP	MAX	UNIT	
L	Nominal inductor value	See Table 6-2	1	1.5	2.2	μH	
	Tolerance		-30%		30%		
C _{OUT}	Output capacitance value	Ceramic, X5R or X7R, see Table 6-3	10	22	100 ⁽¹⁾	μF	
DCDC3 (1.2-V BUCK)							
V _{IN_DCDC3}	Input voltage range	V _{IN_BIAS} > V _{UVLO}	2.7		5.5	V	
V _{DCDC3}	Output voltage range	Adjustable through I ² C	0.9		3.4	V	
	DC accuracy	2.7 V ≤ V _{IN} ≤ 5.5 V; 0 A ≤ I _{OUT} ≤ 1.8 A, V _{IN_DCDC3} ≥ (V _{DCDC3} + 700 mV)	-2%		2%		
	Dynamic accuracy	In respect to nominal output voltage I _{OUT} = 50 mA to 450 mA in < 1 μs C _{OUT} ≥ 10 μF, over full input voltage range	-2.5%		-2.5%		
I _{OUT}	Continuous output current	V _{IN_DCDC3} > 2.7 V			1.8	A	
I _Q	Quiescent current	Total current from IN_DCDC3 pin; Device not switching, no load		25	50	μA	
R _{DS(ON)}	High-side FET on resistance	V _{IN_DCDC3} = 3.6 V		230	345	mΩ	
	Low-side FET on resistance	V _{IN_DCDC3} = 3.6 V		100	150		
I _{LIMIT}	High-side current limit	V _{IN_DCDC3} = 3.6 V		2.8		A	
	Low-side current limit	V _{IN_DCDC3} = 3.6 V		3			
V _{PG}	Power-good threshold	V _{OUT} falling	STRICT = 0b	88.5%	90%	91.5%	
			STRICT = 1b	95%	95.5%	96%	
	Hysteresis	V _{OUT} rising	STRICT = 0b	3.8%	4.1%	4.4%	
			STRICT = 1b		0.25%		
	Deglitch	V _{OUT} falling	STRICT = 0b		1		ms
			STRICT = 1b		50		μs
		V _{OUT} rising	STRICT = 0b		10		μs
			STRICT = 1b		10		μs
Time-out	Occurs at enable of DCDC3 and after DCDC3 register write (register 0x18)			5		ms	
V _{OV}	Overvoltage detection threshold	V _{OUT} rising, STRICT = 1b	104%	104.5%	105%		
	Hysteresis	V _{OUT} falling, STRICT = 1b		0.25%			
	Deglitch	V _{OUT} rising, STRICT = 1b		50		μs	
I _{INRUSH}	Inrush current	V _{IN_DCDC3} = 3.6 V; C _{OUT} = 10 μF to 100 μF			500	mA	
R _{DIS}	Discharge resistor		150	250	350	Ω	
L	Nominal inductor value	See Table 6-2	1.0	1.5	2.2	μH	
	Tolerance		-30%		30%		
C _{OUT}	Output capacitance value	Ceramic, X5R or X7R, see Table 6-3	10	22	100	μF	
DCDC4 (3.3-V BUCK-BOOST) / ANALOG AND I/O							
V _{IN_DCDC4}	Input voltage operating range	V _{IN_BIAS} > V _{UVLO} , -40°C to +105°C	2.8		5.5	V	
V _{DCDC4}	Output voltage range	Adjustable through I ² C	1.175		3.4	V	

Electrical Characteristics (continued)

over operating free-air temperature range (unless otherwise noted)

PARAMETER		TEST CONDITIONS		MIN	TYP	MAX	UNIT
V _{DCDC4}	DC accuracy	4.2 V ≤ V _{IN} ≤ 5.5 V; 3 V < V _{OUT} ≤ 3.4 V 0 A ≤ I _{OUT} ≤ 1.6 A		-2%		2%	
		3.3 V ≤ V _{IN} ≤ 4.2 V; 3 V < V _{OUT} ≤ 3.4 V 0 A ≤ I _{OUT} ≤ 1.3 A		-2%		2%	
		2.8 V ≤ V _{IN} ≤ 3.3 V; 3 V < V _{OUT} ≤ 3.4 V 0 A ≤ I _{OUT} ≤ 1 A		-2%		2%	
		2.8 V ≤ V _{IN} ≤ 5.5 V; 1.65 V < V _{OUT} ≤ 3 V 0 A ≤ I _{OUT} ≤ 1 A		-2%		2%	
		2.8 V ≤ V _{IN} ≤ 5.5 V; 1.175 V < V _{OUT} ≤ 1.65 V 0 A ≤ I _{OUT} ≤ 1 A		-2.5%		2.5%	
Output voltage ripple		PFM mode enabled; 4.2 V ≤ V _{IN} ≤ 5.5 V; 0 A ≤ I _{OUT} ≤ 1.6 A V _{OUT} = 3.3 V				150	mV _{pp}
Minimum duty cycle in step-down mode						18%	
I _{OUT}	Continuous output current	V _{IN_DCDC4} = 2.8 V, V _{OUT} = 3.3 V				1	A
		V _{IN_DCDC4} = 3.6 V, V _{OUT} = 3.3 V				1.3	
		V _{IN_DCDC4} = 5 V, V _{OUT} = 3.3 V				1.6	
I _Q	Quiescent current	Total current from IN_DCDC4 pin; Device not switching, no load			25	50	μA
f _{SW}	Switching frequency				2400		kHz
R _{DS(ON)}	High-side FET on resistance	V _{IN_DCDC3} = 3.6 V	IN_DCDC4 to L4A		166		mΩ
			L4B to DCDC4		149		
	Low-side FET on resistance	V _{IN_DCDC3} = 3.6 V	L4A to GND		142	190	
			L4B to GND		144	190	
I _{LIMIT}	Average switch current limit	V _{IN_DCDC4} = 3.6 V			3000		mA
V _{PG}	Power-good threshold	V _{OUT} falling	STRICT = 0b	88.5%	90%	91.5%	
			STRICT = 1b	95%	95.5%	96%	
	Hysteresis	V _{OUT} rising	STRICT = 0b	3.8%	4.1%	4.4%	
			STRICT = 1b		0.25%		
	Deglitch	V _{OUT} falling	STRICT = 0b		1		ms
			STRICT = 1b		50		μs
		V _{OUT} rising	STRICT = 0b		10		μs
			STRICT = 1b		10		μs
Time-out	Occurs at enable of DCDC4 and after DCDC4 register write (register 0x19)			5		ms	
V _{OV}	Overvoltage detection threshold	V _{OUT} rising, STRICT = 1b		104%	104.5%	105%	
	Hysteresis	V _{OUT} falling, STRICT = 1b			0.25%		
	Deglitch	V _{OUT} rising, STRICT = 1b			50		μs
I _{INRUSH}	Inrush current	V _{IN_DCDC4} = 3.3 V ≤ V _{INDCDC4} ≤ 5.5 V; 40 μF ≤ C _{OUT} ≤ 100 μF				500	mA
R _{DIS}	Discharge resistor			150	250	350	Ω
L	Nominal inductor value	See Table 6-2		1.2	1.5	2.2	μH
	Tolerance			-30%		30%	
C _{OUT}	Output capacitance value	Ceramic, X5R or X7R, see Table 6-3		40	80	100	μF
DCDC5, DCDC6 POWER PATH							

Electrical Characteristics (continued)

over operating free-air temperature range (unless otherwise noted)

PARAMETER		TEST CONDITIONS	MIN	TYP	MAX	UNIT
V _{CC}	DCDC5, 6 input voltage range	V _{IN_BU} = 0 V	2.2		3.3	V
V _{IN_BU}	DCDC5, 6 input voltage range ⁽²⁾		2.2		5.5	V
t _{RISE}	V _{CC} , V _{IN_BU} rise time	V _{CC} = 0 V to 3.3 V, V _{IN_BU} = 0 V to 5.5 V	30			μs
R _{DS(ON)}	Power path switch impedance	CC to SYS_BU V _{CC} = 2.4 V, V _{IN_BU} = 0 V		14.5		Ω
	Power path switch impedance	IN_BU to SYS_BU V _{IN_BU} = 3.6 V		10.5		
I _{LEAK}	Forward leakage current	Into CC pin; V _{CC} = 3.3 V, V _{IN_BU} = 0 V; OFF state; FSEAL = 0b; over full temperature range		50	300	nA
	Reverse leakage current	Out of CC pin; V _{CC} = 1.5 V; V _{IN_BU} = 5.5 V; over full temperature range			500	
R _{CC}	Acceptable CC source impedance	I _{OUT, DCDC5} < 10 μA; I _{OUT, DCDC6} < 10 μA			1000	Ω
I _Q	Quiescent current	Average current into CC pin; RECOVERY or OFF state; V _{IN_BU} = 0 V; V _{CC} = 2.4 V; DCDC5 and DCDC6 enabled, no load T _J = 25°C		350		nA
Q _{INRUSH}	Inrush charge	V _{IN_BIAS} = decaying; CC = 3 V; C _{SYS_BU} = 1 μF; SYS_BU = 2.3 V to 3 V; C _{series_resist} = 10 Ω C _{CC} = 4.7 μF		720		nC
	DCDC5 and DCDC6 band-gap sampling period	T _J = 25°C		400		ms
DCDC5 (1-V BATTERY BACKUP SUPPLY)						
V _{DCDC5}	Output voltage			1		V
	DC accuracy	2.7 V ≤ V _{IN_BU} ≤ 5.5 V; 1.5 μA ≤ I _{OUT} ≤ 25 mA -40°C ≤ T _A < 0°C	-2.5%		2.5%	
		2.7 V ≤ V _{IN_BU} ≤ 5.5 V 1.5 μA ≤ I _{OUT} ≤ 25 mA 0°C ≤ T _A < 105°C	-2%		2%	
		2.2 V ≤ V _{CC} ≤ 3.3 V; V _{IN_BU} = 0; 1.5 μA ≤ I _{OUT} ≤ 100 μA	-2.5%		2.5%	
Output voltage ripple	L = 10 μH; C _{OUT} = 22 μF; 100-μA load, occurs during band-gap sampling			32 ⁽³⁾		mV _{pp}
I _{OUT}	Continuous output current	2.2 V ≤ V _{CC} ≤ 3.3 V V _{IN_BU} = 0 V		10	100	μA
		2.7 V ≤ V _{IN_BU} ≤ 5.5 V			25	mA
R _{DS(ON)}	High-side FET on resistance	V _{IN_BU} = 2.8 V		2.5	3.5	Ω
	Low-side FET on resistance	V _{IN_BU} = 2.8 V		2	3	
I _{LIMIT}	High-side current limit	V _{IN_BU} = 2.8 V		50		mA
V _{PG}	Power-good threshold	V _{OUT} falling	79%	85%	91%	
	Hysteresis	V _{OUT} rising		6%		
L	Nominal inductor value	Chip inductor, see Table 6-2	4.7	10	22	μH
	Tolerance		-30%		30%	
C _{OUT}	Output capacitance value	Ceramic, X5R or X7R, see Table 6-3	20 ⁽⁴⁾		47	μF
	Tolerance		-20%		20%	
DCDC6 (1.8-V BATTERY BACKUP SUPPLY)						
V _{DCDC6}	Output voltage			1.8		V

(2) IN_BU has priority over CC input.

(3) For PHP package: 160mVpp at -40°C, and 120mVpp from 25°C to 105°C.

(4) For PHP package: 40μF.

Electrical Characteristics (continued)

over operating free-air temperature range (unless otherwise noted)

PARAMETER		TEST CONDITIONS	MIN	TYP	MAX	UNIT
V _{DCDC6}	DC accuracy	2.7 V ≤ V _{IN,BU} ≤ 5.5 V; 1 μA ≤ I _{OUT} ≤ 25 mA	-2%		2%	
		2.2 V ≤ V _{CC} ≤ 3.3 V, V _{IN,BU} = 0; 1 μA ≤ I _{OUT} ≤ 100 μA	-2%		2%	
V _{DCDC6}	Output voltage ripple	L = 10 μH; C _{OUT} = 22 μF; 100-μA load			30 ⁽³⁾	mV _{pp}
I _{OUT}	Continuous output current	2.2 V ≤ V _{CC} ≤ 3.3 V V _{IN,BU} = 0 V		10	100	μA
		2.7 V ≤ V _{IN,BU} ≤ 5.5 V			25	mA
R _{DS(ON)}	High-side FET on resistance	V _{IN,BU} = 3 V		2.5	3.5	Ω
	Low-side FET on resistance	V _{IN,BU} = 3 V		2	3	
I _{LIMIT}	High-side current limit	V _{IN,BU} = 3 V		50		mA
V _{PG}	Power-good threshold	V _{OUT} falling	87%	91%	95%	
	Hysteresis	V _{OUT} rising		3%		
L	Nominal inductor value	Chip inductor, see Table 6-2	4.7	10	22	μH
	Tolerance		-30%		30%	
C _{OUT}	Output capacitance value	Ceramic, X5R or X7R, see Table 6-3	20 ⁽⁴⁾		47	μF
	Tolerance		-20%		20%	

Electrical Characteristics (continued)

over operating free-air temperature range (unless otherwise noted)

PARAMETER		TEST CONDITIONS	MIN	TYP	MAX	UNIT	
LDO1 (1.8-V LDO)							
V _{IN_LDO1}	Input voltage range	V _{IN_BIAS} > V _{UVLO}	1.8		5.5	V	
I _Q	Quiescent current	No load		35		μA	
V _{OUT}	Output voltage range	Adjustable through I ² C	0.9		3.4	V	
	DC accuracy	V _{OUT} + 0.2 V ≤ V _{IN} ≤ 5.5 V; 0 A ≤ I _{OUT} ≤ 200 mA	–2%		2%		
I _{OUT}	Output current range	V _{IN_LDO1} – V _{DO} = V _{OUT}	0		200	mA	
		V _{IN_LDO1} > 2.7 V, V _{OUT} = 1.8 V	0		400		
I _{LIMIT}	Short circuit current limit	Output shorted to GND	445	550		mA	
V _{DO}	Dropout voltage	I _{OUT} = 100 mA, V _{IN} = 3.6 V			200	mV	
V _{PG}	Power-good threshold	V _{OUT} falling	STRICT = 0b	86%	90%	94%	
			STRICT = 1b	95%	95.5%	96%	
		Hysteresis, V _{OUT} rising	STRICT = 0b	3%	4%	5%	
			STRICT = 1b		0.25%		
	Deglitch	V _{OUT} falling	STRICT = 0b		1		ms
			STRICT = 1b		50		μs
		V _{OUT} rising	STRICT = 0b		10		μs
			STRICT = 1b		10		μs
	Time-out	Occurs at enable of LDO and after LDO register write (register 0x1B)		5		ms	
	V _{Ov}	Overvoltage detection threshold	V _{OUT} rising, STRICT = 1b	104%	104.5%	105%	
Hysteresis		V _{OUT} falling, STRICT = 1b		0.25%			
Deglitch		V _{OUT} rising, STRICT = 1b		50		μs	
		V _{OUT} falling, STRICT = 1b		1		ms	
R _{DIS}	Discharge resistor		150	250	380	Ω	
C _{OUT}	Output capacitance value	Ceramic, X5R or X7R		22	100	μF	
LOAD SWITCH 1 (LS1)							
V _{IN_LS1}	Input voltage range	V _{IN_BIAS} > V _{UVLO}	1.2		3.6	V	
R _{DS(ON)}	Static on resistance	V _{IN_LS1} = 3.3 V, I _{OUT} = 300 mA, over full temperature range			110	mΩ	
		V _{IN_LS1} = 1.8 V, I _{OUT} = 300 mA, DDR2, LPDDR, MDDR at 266 MHz over full temperature range			110		
		V _{IN_LS1} = 1.5 V, I _{OUT} = 300 mA, DDR3 at 333 MHz over full temperature range			110		
		V _{IN_LS1} = 1.35 V, I _{OUT} = 300 mA, DDR3L at 333 MHz over full temperature range			110		
		V _{IN_LS1} = 1.2 V, I _{OUT} = 200 mA, LPDDR2 at 333 MHz over full temperature range			150		
I _{LIMIT}	Short circuit current limit	Output shorted to GND	350			mA	
t _{BLANK}	Interrupt blanking time	Output shorted to GND until interrupt is triggered		15		ms	
R _{DIS}	Internal discharge resistor at output ⁽⁵⁾	LS1DCHRG = 1	150	250	380	Ω	
T _{OTS}	Overtemperature shutdown ⁽⁶⁾		125	132	139	°C	
	Hysteresis			10			
C _{OUT}	Nominal output capacitance value	Ceramic, X5R or X7R, see Table 6-3	10		100	μF	

(5) Discharge function disabled by default.

(6) Switch is temporarily turned OFF if temperature exceeds OTS threshold.

Electrical Characteristics (continued)

over operating free-air temperature range (unless otherwise noted)

PARAMETER		TEST CONDITIONS	MIN	TYP	MAX	UNIT	
LOAD SWITCH 2 (LS2)							
V_{IN_LS2}	Input voltage range	$V_{IN_BIAS} > V_{UVLO}$	3		5.5	V	
V_{UVLO}	Undervoltage lockout	Measured at IN_LS2. Supply falling ⁽⁷⁾	2.48	2.6	2.7	V	
	Hysteresis	Input voltage rising		170		mV	
$R_{DS(ON)}$	Static on resistance	$V_{IN_LS2} = 5\text{ V}$, $I_{OUT} = 500\text{ mA}$, over full temperature range			500	m Ω	
I_{LIMIT}	Short circuit current limit	Output shorted to GND; $V_{IN_LS2} \geq 4\text{ V}$	LS2ILIM[1:0] = 00b		94	126	mA
			LS2ILIM[1:0] = 01b		188	251	
			LS2ILIM[1:0] = 10b		465	631	
			LS2ILIM[1:0] = 11b		922	1290	
I_{LEAK}	Reverse leakage current	$V_{LS2} > V_{IN_LS2} + 1\text{ V}$		12	30	μA	
t_{BLANK}	Interrupt blanking time	Output shorted to GND until interrupt is triggered		15		ms	
R_{DIS}	Internal discharge resistor at output ⁽⁵⁾	LS2DCHRG = 1b	150	250	380	Ω	
T_{OTS}	Overtemperature shutdown ⁽⁷⁾		125	132	139	$^{\circ}\text{C}$	
	Hysteresis			10			
C_{OUT}	Nominal output capacitance value	Ceramic, X5R or X7R, see Table 6-3	1		100	μF	
LOAD SWITCH 3 (LS3)							
V_{IN_LS3}	Input voltage range	$V_{IN_BIAS} > V_{UVLO}$	1.8		10	V	
$R_{DS(ON)}$	Static on resistance	$V_{IN_LS3} = 9\text{ V}$, $I_{OUT} = 500\text{ mA}$, over full temperature range			440	m Ω	
		$V_{IN_LS3} = 5\text{ V}$, $I_{OUT} = 500\text{ mA}$, over full temperature range			526		
		$V_{IN_LS3} = 2.8\text{ V}$, $I_{OUT} = 200\text{ mA}$, over full temperature range			656		
		$V_{IN_LS3} = 1.8\text{ V}$, $I_{OUT} = 200\text{ mA}$, over full temperature range			910		
I_{LIMIT}	Short circuit current limit	$V_{IN_LS3} > 2.3\text{ V}$, Output shorted to GND	LS3ILIM[1:0] = 00b		98	126	mA
			LS3ILIM[1:0] = 01b		194	253	
			LS3ILIM[1:0] = 10b		475	738	
			LS3ILIM[1:0] = 11b		900	1234	
		$V_{IN_LS3} \leq 2.3\text{ V}$, Output shorted to GND	LS3ILIM[1:0] = 00b		98	126	
			LS3ILIM[1:0] = 01b		194	253	
		LS3ILIM[1:0] = 10b		475	738		
t_{BLANK}	Interrupt blanking time	Output shorted to GND until interrupt is triggered		15		ms	
R_{DIS}	Internal discharge resistor at output ⁽⁵⁾	LS3DCHRG = 1	650	1000	1500	Ω	
T_{OTS}	Overtemperature shutdown ⁽⁷⁾		125	132	139	$^{\circ}\text{C}$	
	Hysteresis			10		$^{\circ}\text{C}$	
C_{OUT}	Nominal output capacitance value	Ceramic, X5R or X7R, see Table 6-3	1	100	220	μF	
BACKUP BATTERY MONITOR							
V_{TH}	Comparator threshold	Ideal level		3		V	
		Good level		2.6		V	
		Low level		2.3		V	
	Accuracy		-3%		3%		
R_{LOAD}	Load impedance	Applied from CC to GND during comparison	70	100	130	k Ω	

(7) Switch is temporarily turned OFF if input voltage drops below UVLO threshold.

Electrical Characteristics (continued)

over operating free-air temperature range (unless otherwise noted)

PARAMETER		TEST CONDITIONS	MIN	TYP	MAX	UNIT
t_{DLY}	Measurement delay	R_{LOAD} is connected during delay time. Measurement is taken at the end of delay.		600		ms
I/O LEVELS AND TIMING CHARACTERISTICS						
PG_{DLY}	PGOOD delay time	PGDLY[1:0] = 00b		10		ms
		PGDLY[1:0] = 01b		20		
		PGDLY[1:0] = 10b		50		
		PGDLY[1:0] = 11b		150		
t_{DG}	Deglitch time	PB input	Rising edge		100	ms
			Falling edge		50	ms
		AC_DET input	Rising edge		100	μ s
			Falling edge		10	ms
		PWR_EN input	Rising edge		10	ms
			Falling edge		100	μ s
		GPIO1	Rising edge		1	ms
			Falling edge		1	ms
		GPIO3	Rising edge		5	μ s
			Falling edge		5	μ s
t_{RESET}	Reset time	PB input held low	TRST = 0b		8	s
			TRST = 1b		15	
V_{IH}	High level input voltage	SCL, SDA, GPIO1, GPIO3		1.3		V
		AC_DET, PB		$0.66 \times$ IN_BIAS		
		PWR_EN		1.3		
V_{IL}	Low level input voltage	SCL, SDA, PWR_EN, AC_DET, PB, GPIO1, GPIO3		0	0.4	V
V_{OH}	High level output voltage	GPO2; $I_{SOURCE} = 5$ mA; GPO2_BUF = 1		$V_{IN_LS1} -$ 0.3	V_{IN_LS1}	V
		PGOOD_BU; $I_{SOURCE} = 100$ μ A		$V_{DCDC6} -$ 10 mV		
V_{OL}	Low level output voltage	nWAKEUP, nINT, SDA, PGOOD, GPIO1, GPO2, GPIO3; $I_{SINK} = 2$ mA		0	0.3	V
		nPFO; $I_{SINK} = 2$ mA		0	0.35	
		PGOOD_BU; $I_{SINK} = 100$ μ A		0	0.3	
V_{PFI}	Power-fail comparator threshold	Input falling		800		mV
	Hysteresis	Input rising		40		mV
	Accuracy			-4%	4%	
	Deglitch	Input falling			25	
Input rising				10		ms
I_{DC34_SEL}	DC34_SEL bias current	Enabled only at power-up	9.05	10	11.93	μ A
V_{DC34_SEL}	DCDC3 / DCDC4 power-up default selection thresholds	Threshold 1		100		mV
		Threshold 2		163		
		Threshold 3		275		
		Threshold 4		400		
		Threshold 5		575		
		Threshold 6		825		
		Threshold 7		1200		

Electrical Characteristics (continued)

over operating free-air temperature range (unless otherwise noted)

PARAMETER		TEST CONDITIONS	MIN	TYP	MAX	UNIT
R _{DC34_SEL}	DCDC3 / DCDC4 power-up default selection resistor values	Setting 0	0	0	7.7	kΩ
		Setting 1	11.8	12.1	12.4	
		Setting 2	19.5	20	20.5	
		Setting 3	30.9	31.6	32.3	
		Setting 4	44.4	45.3	46.3	
		Setting 5	64.8	66.1	67.3	
		Setting 6	93.6	95.3	97.2	
		Setting 7	146	150		
I _{BIAS}	Input bias current	SCL, SDA, GPIO1 ⁽⁸⁾ , GPIO3 ⁽⁸⁾ ; V _{IN} = 3.3 V		0.01	1	μA
		PB, AC_DET, PFI; V _{IN} = 3.3 V			500	nA
I _{LEAK}	Pin leakage current	nINT, nWAKEUP, nPFO, PGOOD, PWR_EN, GPIO1 ⁽⁹⁾ , GPO2 ⁽¹⁰⁾ , GPIO3 ⁽⁹⁾ V _{OUT} = 3.3 V			500	nA
OSCILLATOR						
f _{OSC}	Oscillator frequency			2400		kHz
	Frequency accuracy	T _J = -40°C to +105°C	-12%		12%	
OVERTEMPERATURE SHUTDOWN						
T _{OTS}	Overtemperature shutdown	Increasing junction temperature	135	145	155	°C
	Hysteresis	Decreasing junction temperature		20		
T _{WARN}	High-temperature warning	Increasing junction temperature	90	100	110	°C
	Hysteresis	Decreasing junction temperature		15		

(8) Configured as input.

(9) Configured as output.

(10) Configured as open-drain output.

4.6 Timing Requirements

		MIN	NOM	MAX	UNIT
f _{SCL}	Serial clock frequency		100		kHz
			400		
t _{HD;STA}	Hold time (repeated) START condition. After this period, the first clock pulse is generated.	SCL = 100 kHz	4		μs
		SCL = 400 kHz	600		ns
t _{LOW}	LOW period of the SCL clock	SCL = 100 kHz	4.7		μs
		SCL = 400 kHz	1.3		
t _{HIGH}	HIGH period of the SCL clock	SCL = 100 kHz	4		μs
		SCL = 400 kHz ⁽¹⁾	1		
t _{SU;STA}	Set-up time for a repeated START condition	SCL = 100 kHz	4.7		μs
		SCL = 400 kHz	600		ns
t _{HD;DAT}	Data hold time	SCL = 100 kHz	0	3.45	μs
		SCL = 400 kHz	0	900	ns
t _{SU;DAT}	Data set-up time	SCL = 100 kHz	250		ns
		SCL = 400 kHz	100		
t _r	Rise time of both SDA and SCL signals	SCL = 100 kHz		1000	ns
		SCL = 400 kHz		300	
t _f	Fall time of both SDA and SCL signals	SCL = 100 kHz		300	ns
		SCL = 400 kHz		300	
t _{SU;STO}	Set-up time for STOP condition	SCL = 100 kHz	4		μs
		SCL = 400 kHz	600		ns

(1) The SCL duty cycle at 400 kHz must be > 40%.

Timing Requirements (continued)

		MIN	NOM	MAX	UNIT
t _{BUF}	Bus free time between STOP and START condition	SCL = 100 kHz	4.7		μs
		SCL = 400 kHz	1.3		
t _{SP}	Pulse width of spikes which must be suppressed by the input filter	SCL = 100 kHz	— ⁽²⁾		ns
		SCL = 400 kHz	0	50	
C _b	Capacitive load for each bus line	SCL = 100 kHz	400		pF
		SCL = 400 kHz	400		

(2) The inputs of I²C devices in Standard-mode do not require spike suppression.

4.7 Typical Characteristics

at $T_J = 25^\circ\text{C}$ unless otherwise noted

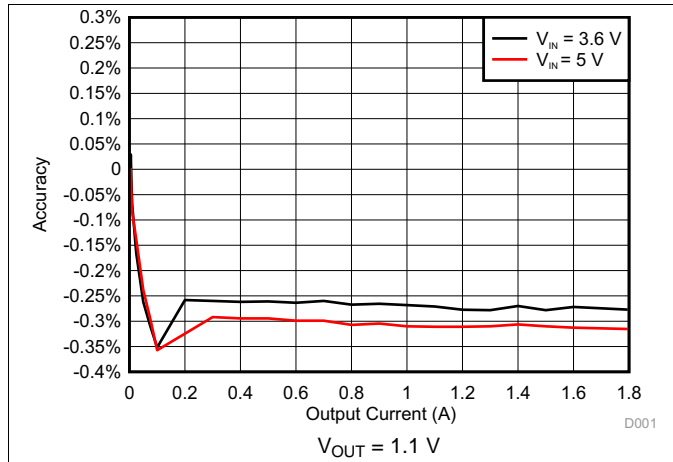

Figure 4-1. DCDC1 Accuracy

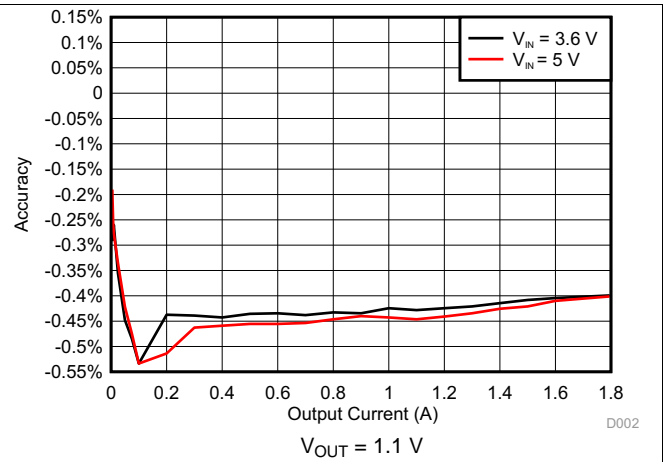

Figure 4-2. DCDC2 Accuracy

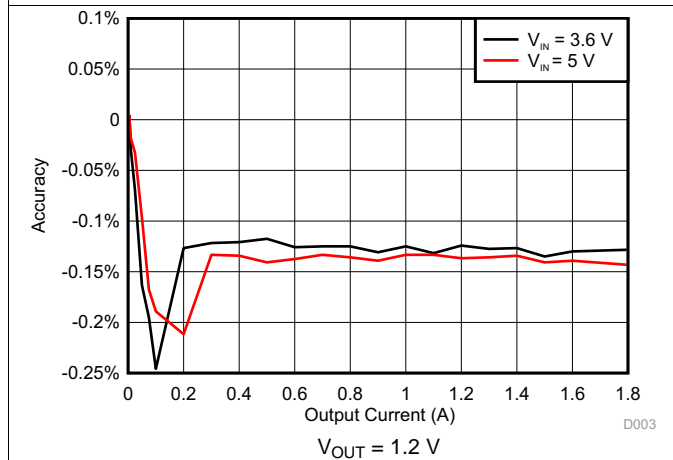

Figure 4-3. DCDC3 Accuracy

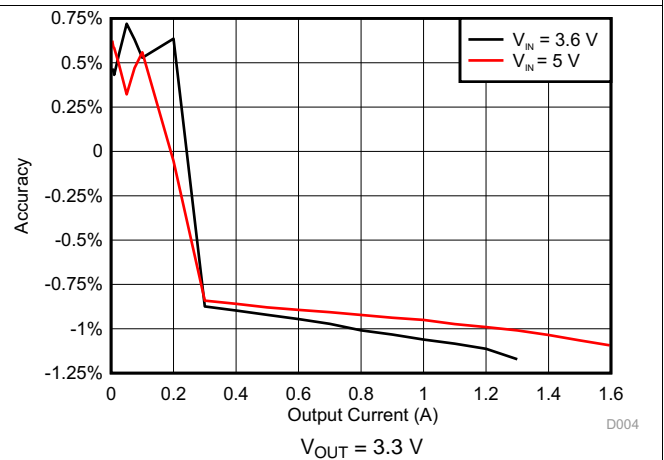

Figure 4-4. DCDC4 Accuracy

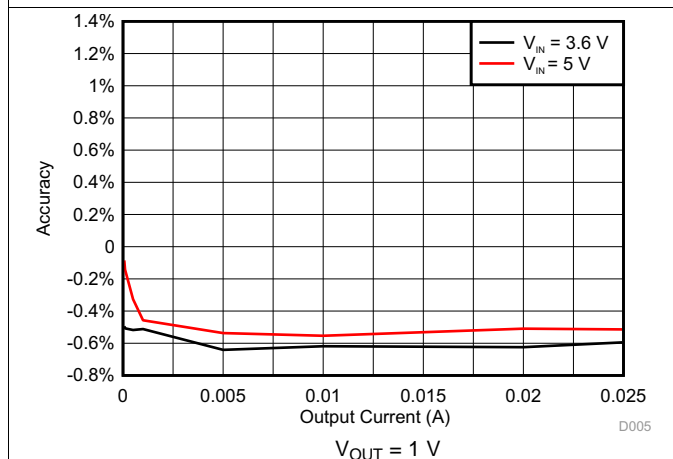

Figure 4-5. DCDC5 Accuracy

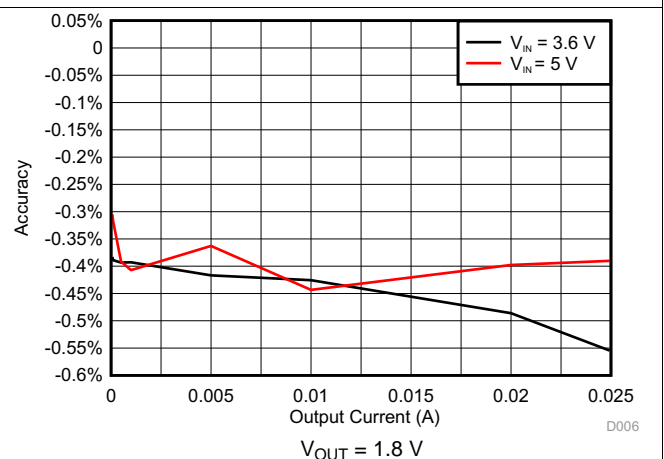

Figure 4-6. DCDC6 Accuracy

5 Detailed Description

5.1 Overview

The TPS65218D0 provides three step-down converters, three load switches, three general-purpose I/Os, two battery backup supplies, one buck-boost converter and one LDO. The system can be supplied by a single cell Li-Ion battery or regulated 5-V supply. A coin-cell battery can be added to supply the two always-on backup supplies. The device is characterized across a -40°C to $+105^{\circ}\text{C}$ temperature range, which makes it suitable for various industrial applications.

The I²C interface provides comprehensive features for using TPS65218D0. All rails, load switches, and GPIOs can be enabled / disabled. Voltage thresholds for the UVLO and supervisor can be customized. Power-up and power-down sequences can also be programmed through I²C. Interrupts for overtemperature, overcurrent, and undervoltage can be monitored for the load-switches (LSx).

The integrated voltage supervisor monitors DCDC 1-4 and LDO1. It has two settings; the standard settings only monitor for undervoltage, while the strict settings implement tight tolerances on both undervoltage and overvoltage. A power good signal is provided to report the regulation state of the five rails.

The three hysteretic step-down converters can each supply up to 1.8 A of current. The default output voltages for each converter can be adjusted through the I²C interface. DCDC 1 and 2 feature dynamic voltage scaling with adjustable slew rate. The step-down converters operate in a low power mode at light load, and can be forced into PWM operation for noise sensitive applications.

The battery backup supplies consist of two low power step-down converters optimized for very light loads and are monitored with a separate power good signal (PGOOD_BU). The converters can be configured to operate as always-on supplies with the addition of a coin cell battery. The state of the battery can be monitored over I²C.

5.2 Functional Block Diagram

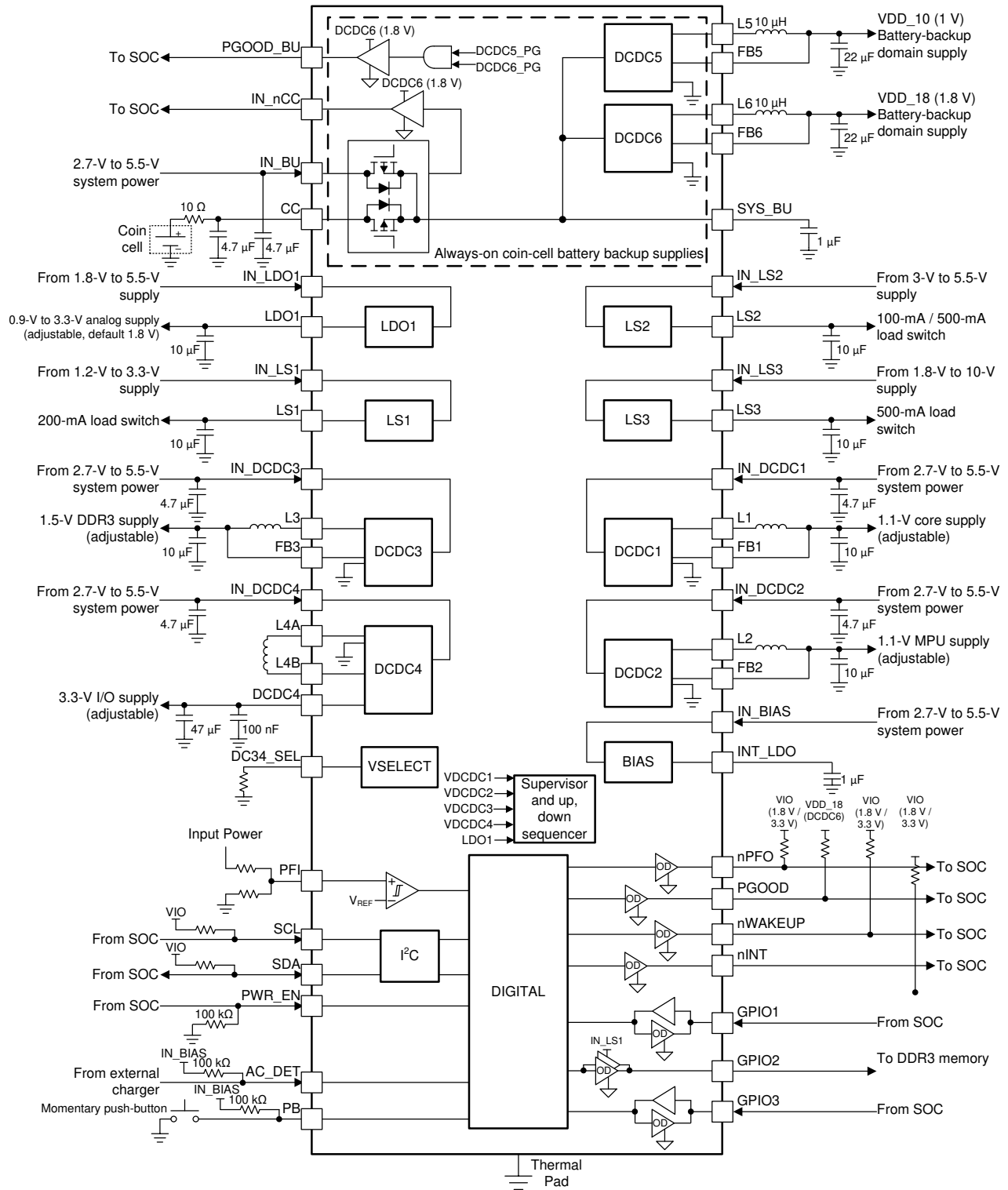

Copyright © 2018, Texas Instruments Incorporated

5.3 Feature Description

5.3.1 Wake-Up and Power-Up and Power-Down Sequencing

The TPS65218D0 has a predefined power-up and power-down sequence, which in a typical application does not need to be changed. The user can define custom sequences with I²C. The power-up sequence is defined by a series of ten strobes and nine delay times. Each output rail is assigned to a strobe to determine the order of enabling rails. A single rail is assigned to only one strobe, but multiple rails can be assigned to the same strobe. The delay times between strobes are between 2 ms and 5 ms.

5.3.1.1 Power-Up Sequencing

When the power-up sequence initiates, STROBE1 occurs, and any rail assigned to this strobe is enabled. After a delay time of DLY1, STROBE2 occurs and the rail assigned to this strobe is powered up. The sequence continues until all strobes occur and all DLYx times execute. Strobe assignments and delay times are defined in the SEQx registers, and are changed under I²C control. The power-up sequence executes if one of the following events occurs:

- From the OFF state:
 - The push-button (PB) is pressed (falling edge on PB) **OR**
 - The AC_DET pin is pulled low (falling edge) **OR**
 - The PWR_EN is asserted (driven to high-level) **OR**
 - The main power is connected (IN_BIAS) and AC_DET is grounded **AND**
 - The device is not in undervoltage lockout (UVLO) or overtemperature shutdown (OTS).
- From the PRE_OFF state:
 - The PB is pressed (falling edge on PB) **OR**
 - The AC_DET pin is pulled low (falling edge) **OR**
 - PWR_EN is asserted (driven to high-level) **AND**
 - The device is not in UVLO or OTS.
- From the SUSPEND state:
 - The PB is pressed (falling edge on PB) **OR**
 - The AC_DET pin is pulled low (falling edge) **OR**
 - The PWR_EN pin is pulled high (level sensitive) **AND**
 - The device is not in UVLO or OTS.

When a power-up event is detected, the device enters a WAIT_PWR_EN state and triggers the power-up sequence. The device remains in WAIT_PWR_EN as long as the PWR_EN and either the PB or AC_DET pin are held low. If both, the PB and AC_DET return to logic-high state and the PWR_EN pin has not been asserted within 20 s of entering WAIT_PWR_EN state, the power-down sequence is triggered and the device returns to OFF state. Once PWR_EN is asserted, the device advances to ACTIVE state, which is functionally equivalent to WAIT_PWR_EN. However, the AC_DET pin is ignored and power-down is controlled by the PWR_EN pin only.

Rails not assigned to a strobe (SEQ = 0000b) are not affected by power-up and power-down sequencing and remain in their current ON/OFF state regardless of the sequencer. A rail can be enabled/disabled at any time by setting the corresponding enable bit in the ENABLEx register, with the exception that the ENABLEx register cannot be accessed while the sequencer is active. Enable bits always reflect the current enable state of the rail, for example the sequencer sets and resets the enable bits for the rails under its control.

NOTE

The power-up sequence is defined by strobes and delay times, and can be triggered by the PB, AC_DET (not shown, same as PB), or PWR_EN pin.

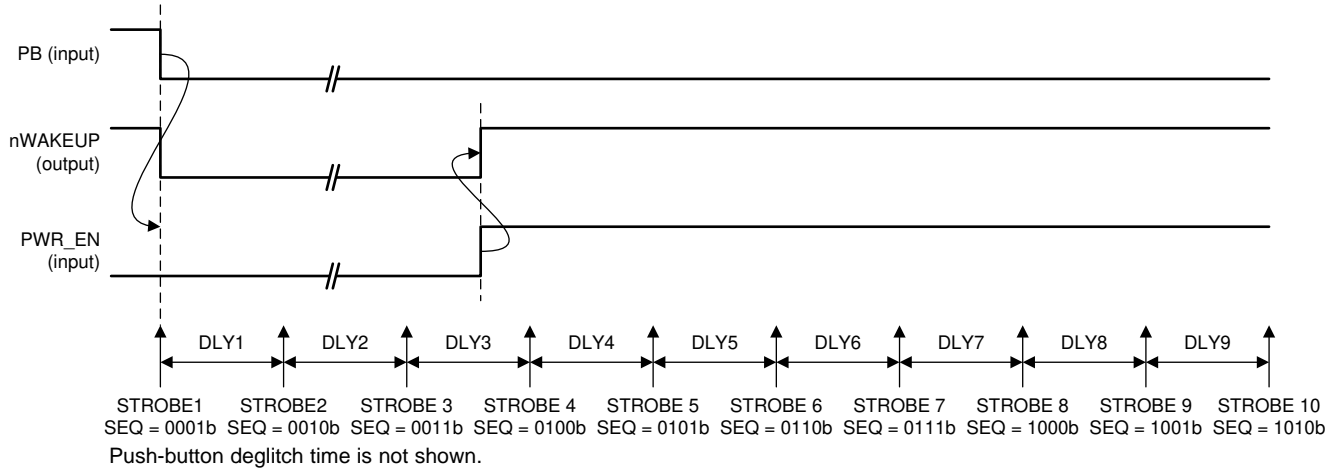

Figure 5-1. Power-Up Sequences from OFF or SUSPEND State; PB is Power-Up Event

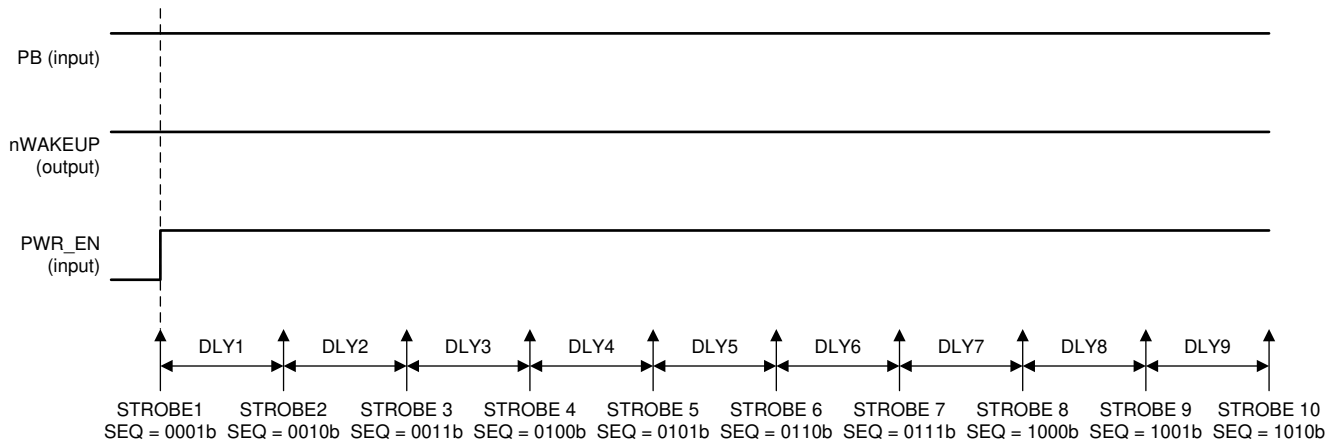

Figure 5-2. Power-Up Sequences from SUSPEND State; PWR_EN is Power-Up Event

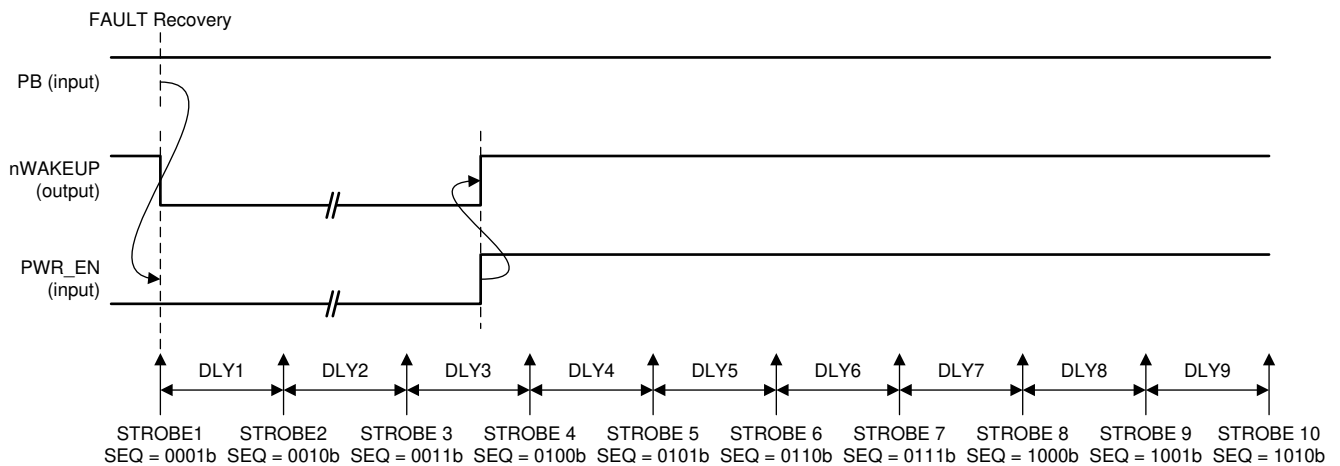

Figure 5-3. Power-Up Sequences from RECOVERY State

5.3.1.2 Power-Down Sequencing

By default, the power-down sequence follows the reverse of the power-up sequence. When the power-down sequence is triggered, STROBE10 occurs and any rail assigned to STROBE10 is shut down and its discharge circuit is enabled. After a delay time of DLY9, STROBE9 occurs and any rail assigned to it is shut down and its discharge circuit is enabled. The sequence continues until all strobes occur and all DLYx times execute. The DLYx times are extended by a factor of 10x to provide ample time for discharge, and preventing output voltages from crossing during shut-down. The DLYFCTR bit is applied globally to all power-down delay times. Regardless of the DLYx and DLYFCTR settings, the PMIC enters OFF, SUSPEND, or RECOVERY state 500 ms after the power-down sequence initiates, to ensure that the discharge circuits remain enabled for a minimum of 150 ms before the next power-up sequence starts.

A power-down sequence executes if one of the following events occurs:

- The device is in the WAIT_PWR_EN state, the PB and AC_DET pins are high, PWR_EN is low, and the 20-s timer has expired.
- The device is in the ACTIVE state and the PWR_EN pin is pulled low.
- The device is in the WAIT_PWR_EN, ACTIVE, or SUSPEND state and the push-button is held low for > 8 s (15 s if TRST = 1b)
- A fault occurs in the IC (OTS, UVLO, PGOOD failure).

When transitioning from ACTIVE to SUSPEND state, rails not controlled by the power-down sequencer maintains the same ON/OFF state in SUSPEND state that it had in ACTIVE state. This allows for the selected power rails to remain powered up when in the SUSPEND state.

When transitioning to the OFF or RECOVERY state, rails not under sequencer control are shut-down as follows:

- DCDC1, 2, 3, 4, LDO1, and LS1 shut down at the beginning of the power-down sequence, if not under sequencer control (SEQ = 0b).
- LS2 and LS3 shut down as the state machine enters an OFF or RECOVERY state; 500 ms after the power-down sequence is triggered.

If the supply voltage on IN_BIAS drops below 2.5 V, the digital core is reset and all power rails are shut down instantaneously and are pulled low to ground by their internal discharge circuitry (DCDC1-4, and LDO1). The amount of time the discharge circuitry remains active is a function of the INT_LDO hold up time (see [Section 5.3.1.6](#) for more details).

5.3.1.3 Strobes 1 and 2

STROBE1 and STROBE2 are dedicated to DCDC5 and DCDC6 which are *always-on*; powered up as soon as the device exits the OFF state, and ON in any other state. STROBE 1 and 2 options are available only for DCDC5 and DCDC6, not for any other rails.

STROBE 1 and STROBE 2 occur in every power-up sequence, regardless if the rail is already powered up. If the rail is not to be powered up, its respective strobe setting must be set to 0x00.

When a power-down sequence initiates, STROBE1 and STROBE2 occur only if the FSEAL bit is 0b. Otherwise, both strobes are omitted and DCDC5 and DCDC6 maintain state.

NOTE

The power-down sequence follows the reverse of the power-up sequence. STROBE2 and STROBE1 are executed only if FSEAL bit is 0b.

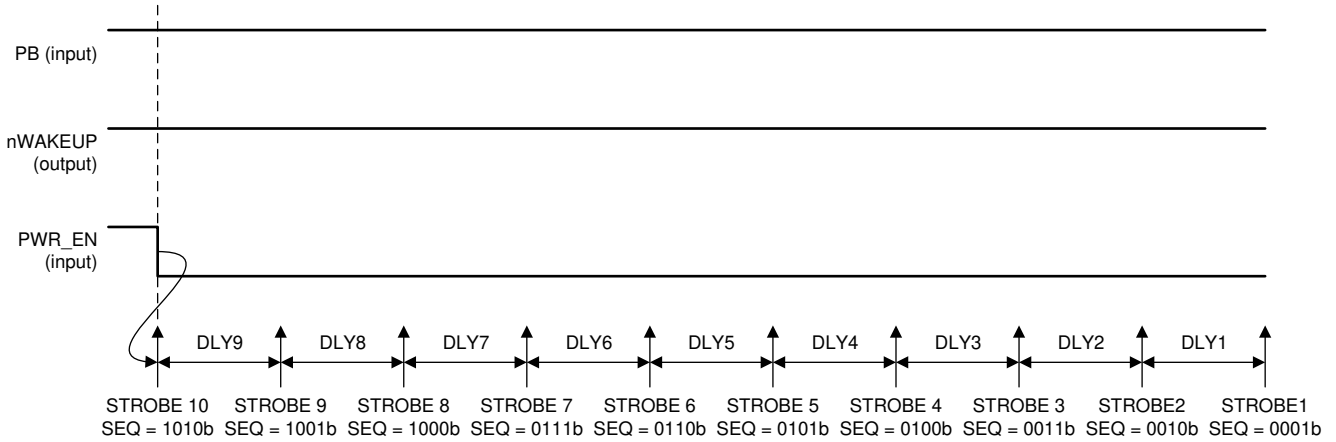

**Figure 5-4. Power-Down Sequences to OFF State;
PWR_EN is Power-Down Event; FSEAL = 0b**

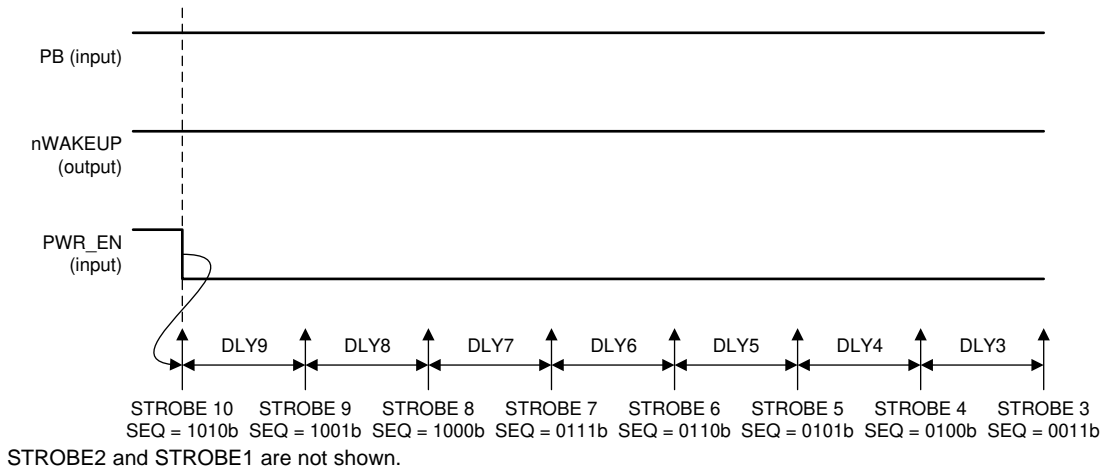

**Figure 5-5. Power-Down Sequences to SUSPEND State;
PWR_EN is Power-Down Event; FSEAL = 1b**

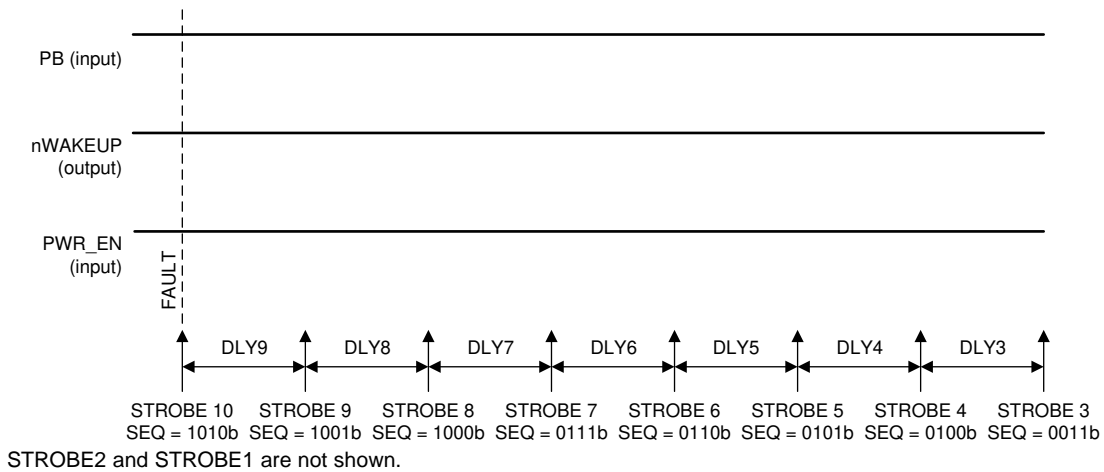

**Figure 5-6. Power-Down Sequences to RECOVERY State;
TSD or UV is Power-Down Event; FSEAL = 1b**

5.3.1.4 Supply Voltage Supervisor and Power Good (PGOOD)

Power-good (PGOOD) is an open-drain output of the built-in voltage supervisor that monitors DCDC1, DCDC2, DCDC3, DCDC4, and LDO1. The output is Hi-Z when all enabled rails are in regulation and driven low when one or more rails encounter a fault which brings the output voltage outside the specified tolerance range. In a typical application PGOOD drives the reset signal of the SOC.

The supervisor has two modes of operation, controlled by the STRICT bit. With the STRICT bit set to 0, all enabled rails of the five regulators are monitored for undervoltage only with relaxed thresholds and deglitch times. With the STRICT bit set to 1, all enabled rails of the five regulators are monitored for undervoltage and overvoltage with tight limits and short deglitch times. Table 5-1 summarizes these details.

Table 5-1. Supervisor Characteristics Controlled by the STRICT Bit

PARAMETER		STRICT = 0b (TYP)	STRICT = 1b (TYP)
Undervoltage monitoring	Threshold (output falling)	90%	96.5% (DCDC1, DCDC2) 95.5% (DCDC3, DCDC4, LDO1)
	Deglitch (output falling)	1 ms	50 μs
	Deglitch (output rising)	10 μs	10 μs
Overvoltage monitoring	Threshold (output falling)	N/A	103.5% (DCDC1, DCDC2) 104.5% (DCDC3, DCDC4, LDO1)
	Deglitch (output falling)	N/A	1 ms
	Deglitch (output rising)	N/A	50 μs

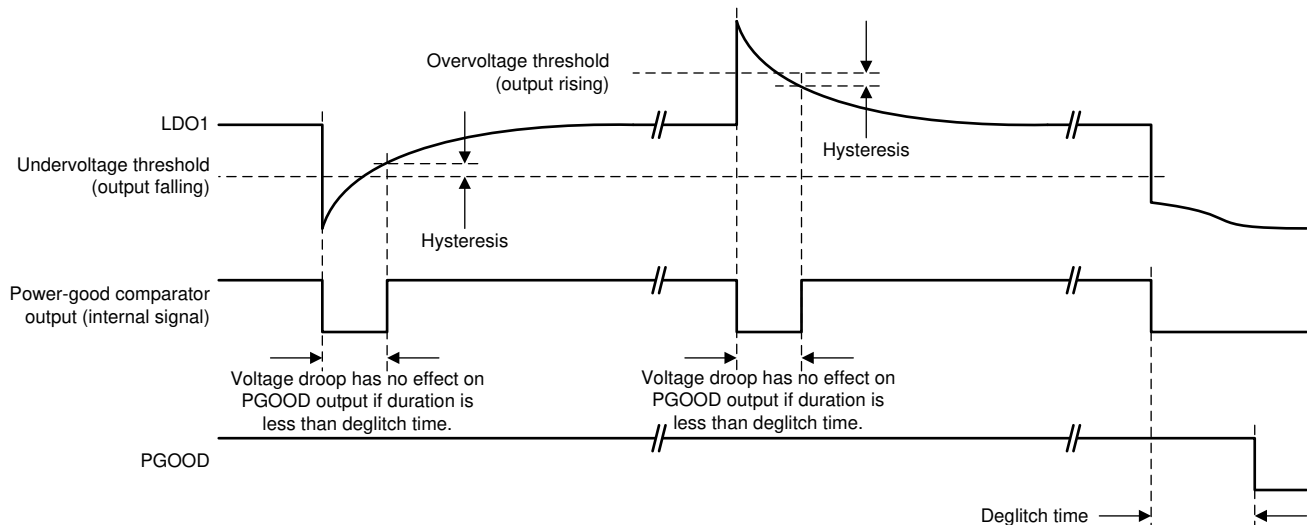

Figure 5-7. Definition of Undervoltage, Overvoltage Thresholds, Hysteresis, and Deglitch Times

The following rules apply to the PGOOD output:

- The power-up default state for PGOOD is low. When all rails are disabled, PGOOD output is driven low.
- Only enabled rails are monitored. Disabled rails are ignored.
- Power-good monitoring of a particular rail starts 5 ms after the rail is enabled and is continuously monitored thereafter. This allows the rail to power-up.
- PGOOD is delayed by PGDLY time after the sequencer is finished and the last rail is enabled.
- If an enabled rail is continuously outside the monitoring threshold for longer than the deglitch time, PGOOD is pulled low, and all rails are shut-down following the power-down sequence. PGDLY does not apply.

- Disabling a rail manually by resetting the DCx_EN or LDO1_EN bit has no effect on the PGOOD pin. If all rails are disabled, PGOOD is driven low as the last rail is disabled.
- If the power-down sequencer is triggered, PGOOD is driven low.
- PGOOD is driven low in SUSPEND state, regardless of the number of rails that are enabled.

Figure 5-8 shows a typical power-up sequence and PGOOD timing.

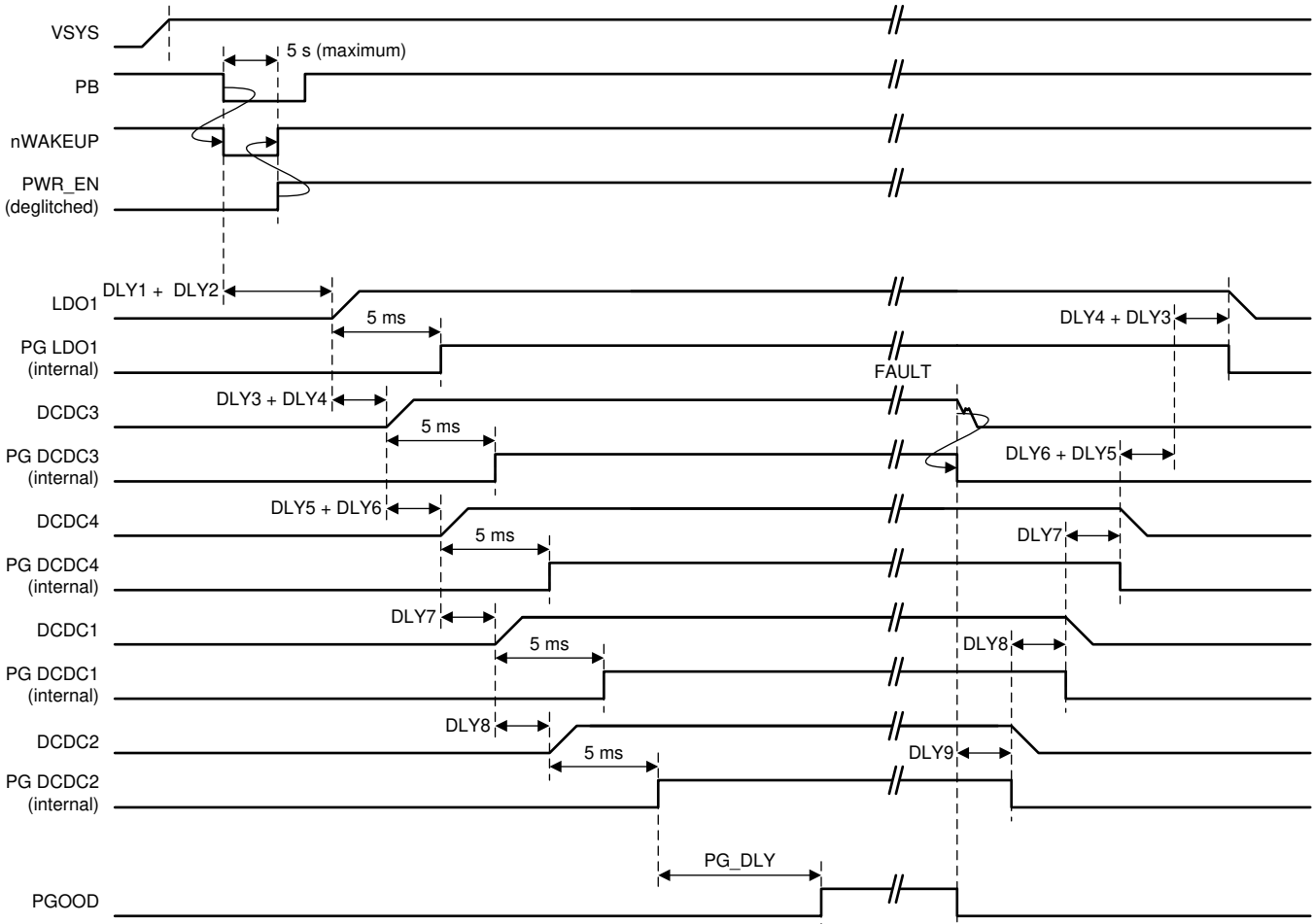

Figure 5-8. Typical Power-Up Sequence of the Main Output Rails

5.3.1.5 Backup Supply Power-Good (PGOOD_BU)

PGOOD_BU is a push-pull output indicating if DCDC5 and DCDC6 are in regulation. The output is driven to high when both rails are in regulation, and driven low if at least one of the rails is below the power-good threshold. The output-high level is equal to the output voltage of DCDC6.

PGOOD_BU is the logical AND between PGOOD(DCDC5) and PGOOD(DCDC6), and has no delay time built-in. Unlike main power-good, a fault on DCDC5 or DCDC6 does not trigger the power-down sequencer, does not disable any of the rails in the system, and has no effect on the PGOOD pin. DCDC5 and DCDC6 recover automatically once the fault is removed.

NOTE

In this example, the power-down is triggered by a fault on DCDC3.

This timing diagram assumes each rail powers up within the strobe delay time. If a rail takes longer than the strobe delay time to power up, the next rail will wait for the previous rail to reach its PGOOD voltage, and then may wait an additional 1ms until it is enabled.

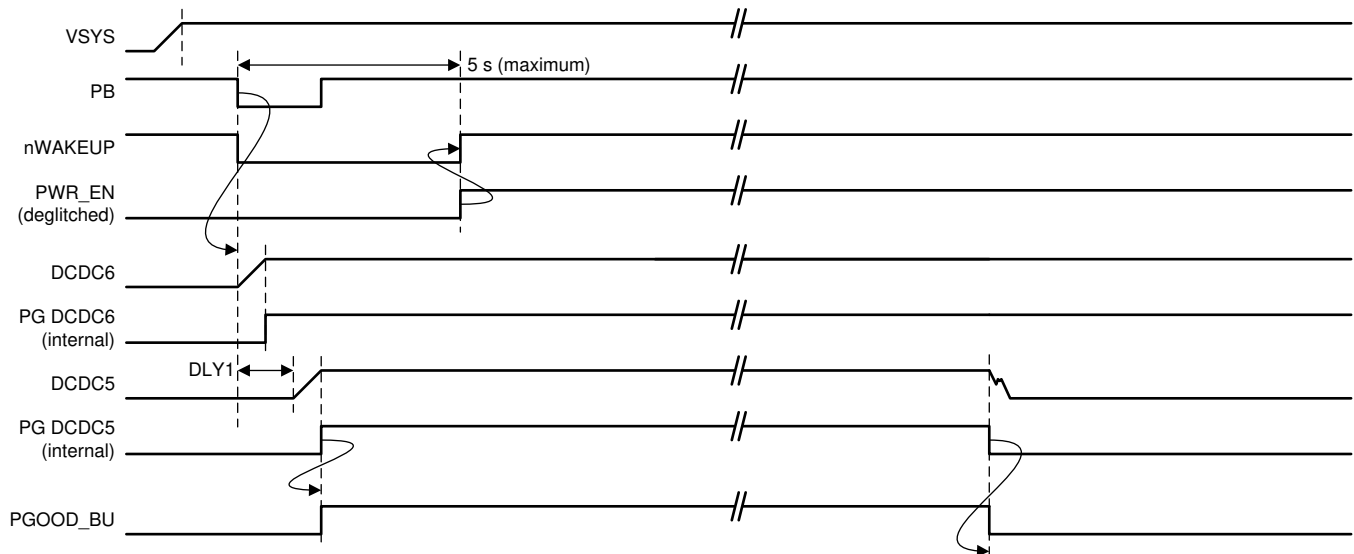

Figure 5-9. Typical Power-Up Sequence of DCDC5 and DCDC6

5.3.1.6 Internal LDO (INT_LDO)

The internal LDO (INT_LDO) provides a regulated voltage to the internal digital core and analog circuitry. The internal LDO has a nominal output voltage of 2.5 V and can support up to 10 mA of external load. During EEPROM programming, the output voltage is elevated to 3.6 V as described in [Section 5.5.1](#). Therefore, any external circuitry connected to INT_LDO must be capable of supporting that voltage.

When system power fails, the UVLO comparator triggers the power-down sequence. If system power drops below 2.3 V, the digital core is reset and all remaining power rails are shut down instantaneously and are pulled low to ground by their internal discharge circuitry (DCDC1-4, and LDO1).

The internal LDO reverse blocks to prevent the discharging of the output capacitor (C_{INT_LDO}) on the INT_LDO pin. The remaining charge on the INT_LDO output capacitor provides a supply for the power rail discharge circuitry to ensure the outputs are discharged to ground even if the system supply has failed. The amount of hold-up time specified in [Section 4.5](#) is a function of the output capacitor value (C_{INT_LDO}) and the amount of external load on the INT_LDO pin, if any. The design allows for enough hold-up time to sufficiently discharge DCDC1-4, and LDO1 to ensure proper processor power-down sequencing.

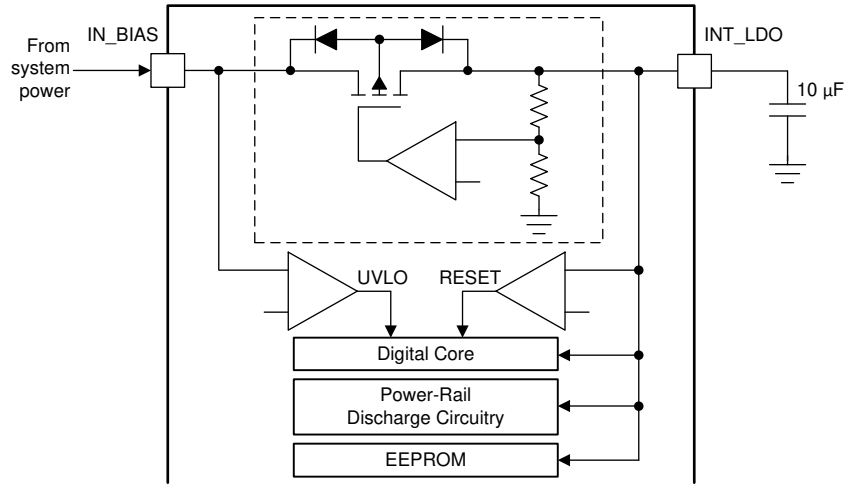

Figure 5-10. Internal LDO and UVLO Sensing

5.3.1.7 Current Limited Load Switches

The TPS65218D0 provides three current limited load switches with individual inputs, outputs, and enable control. Each switch provides the following control and diagnostic features:

- The ON/OFF state of the switch is controlled by the corresponding LSx_EN bit in the ENABLE register.
- LS1 can be controlled by the sequencer or through I²C communication.
- LS2 and LS3 can ONLY be controlled through I²C communication. The sequencer has no control over LS2 and LS3.
- Each switch has an active discharge function, disabled by default, and enabled through the LSxDCHRG bit. When enabled, the switch output is discharged to ground whenever the switch is disabled.
- When the PFI input drops below the power-fail threshold (the power-fail comparator trips), the load switches are automatically disabled to shed system load. This function must be individually enabled for each switch through the corresponding LSxnPFO bit. The switches do not turn back on automatically as the system voltage recovers, and must be manually re-enabled.
- An interrupt (LSx_I) issues whenever a load switch actively limits the output current, such as when the output load exceeds the current limit value. The switch remains ON and provides current to the load according to the current-limit setting.
- All three load switches have local overtemperature sensors which disable the corresponding switch if the power dissipation and junction temperature exceeds safe operating value. The switch automatically recovers once the temperature drops below the OTS threshold value minus hysteresis. The LSx_F (fault) interrupt bit is set while the switch is held OFF by the OTS function.

5.3.1.7.1 Load Switch 1 (LS1)

LS1 is a non-reverse blocking, low-voltage (< 3.6 V), low-impedance switch intended to support DDRx self-refresh mode by cutting off the DDRx supply to the SOC DDRx interface during SUSPEND mode. In a typical application, the input of LS1 is tied to the output of DCDC3 while the output of LS1 is connected to the memory-interface supply pin of the SOC. LS1 can be controlled by the internal sequencer, just as any power rail.

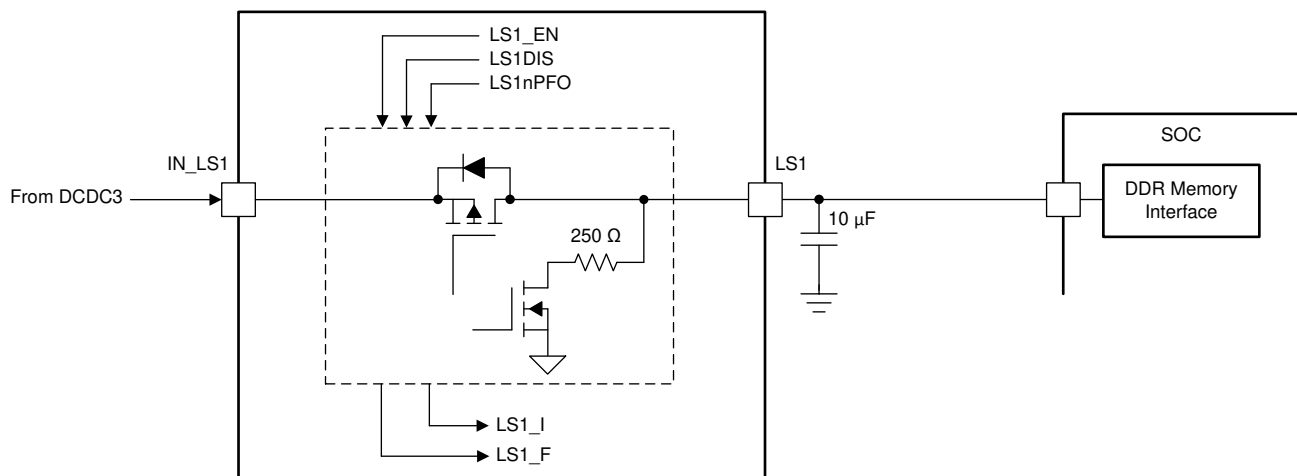

Figure 5-11. Typical Application of Load Switch 1

5.3.1.8 LDO1

LDO1 is a general-purpose LDO intended to provide power to analog circuitry on the SOC. LDO1 has an input voltage range from 1.8 V to 5.5 V, and can be connected either directly to the system power or the output of a DCDC converter. The output voltage is programmable in the range of 0.9 V to 3.4 V with a default of 1.8 V. LDO1 supports up to 200 mA at the minimum specified headroom voltage, and up to 400 mA at the typical operating condition of $V_{OUT} = 1.8\text{ V}$, $V_{IN_LDO1} > 2.7\text{ V}$.

5.3.1.9 Coin Cell Battery Voltage Acquisition

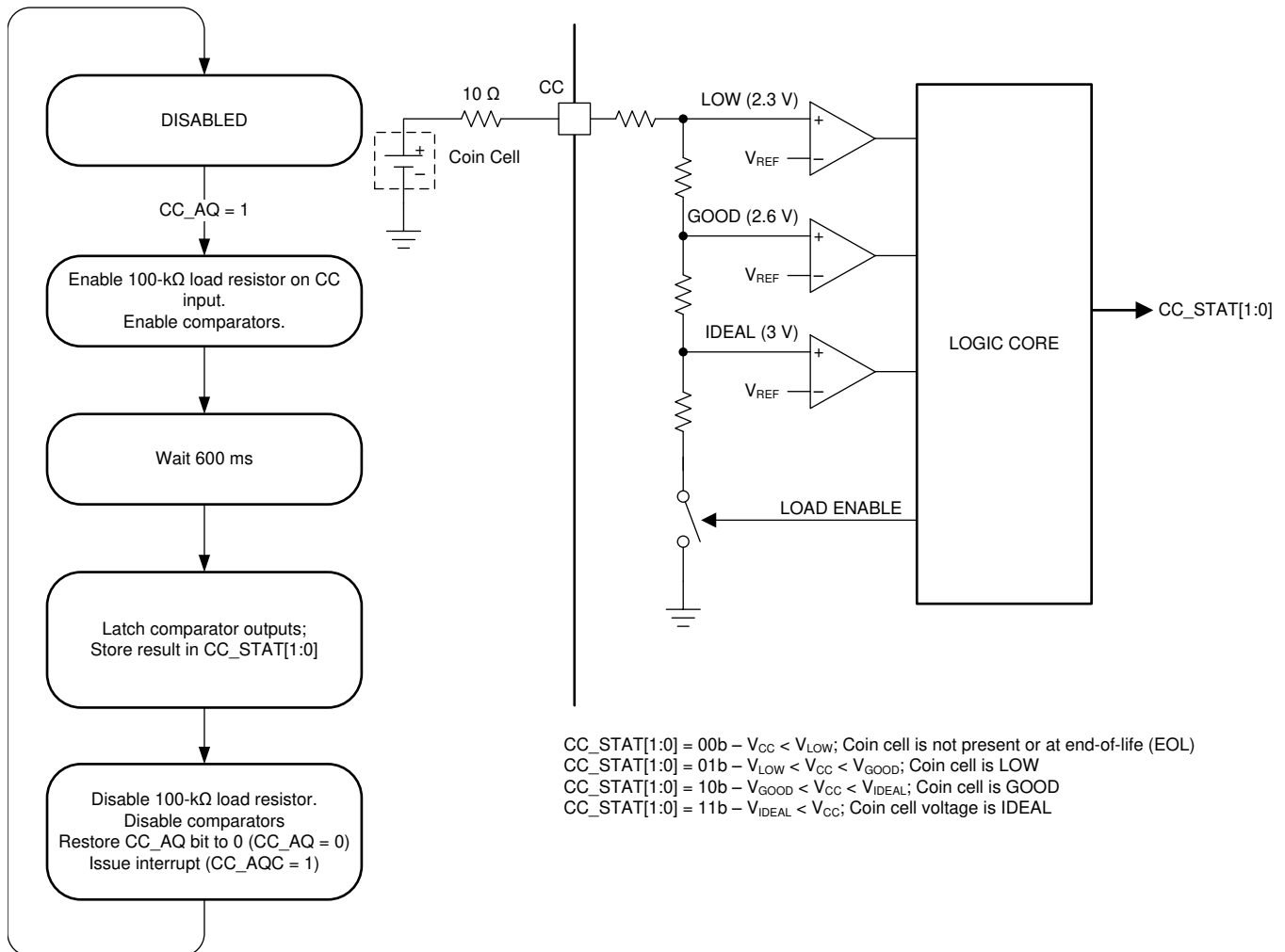

Figure 5-14. Left: Flow Chart for Acquiring Coin Cell Battery Voltage
 Right: Comparator Circuit

5.3.1.10 UVLO

Depending on the slew rate of the input voltage into the IN_BIAS pin, the power rails of TPS65218D0 will be enabled at either V_{ULVO} or $V_{ULVO} + V_{HYS}$.

If the slew rate of the IN_BIAS voltage is greater than 30 V/s, then TPS65218D0 will power up at V_{ULVO} . Once the input voltage rises above this level, the input voltage may drop to the V_{ULVO} level before the PMIC shuts down. In this scenario, if the input voltage were to fall below V_{ULVO} but above 2.55 V, the input voltage would have to recover above V_{ULVO} in less than 5 ms for the device to remain active.

If the slew rate of the IN_BIAS voltage is less than 30 V/s, then TPS65218D0 will power up at $V_{UVLO} + V_{HYS}$. Once the input voltage rises above this level, the input voltage may drop to the V_{UVLO} level before the PMIC shuts down. In this scenario, if the input voltage were to fall below V_{UVLO} but above 2.5 V, the input voltage would have to recover above $V_{UVLO} + V_{HYS}$ in less than 5 ms for the device to remain active.

In either slew rate scenario, if the input voltage were to fall below 2.5 V, the digital core is reset and all remaining power rails are shut down instantaneously and are pulled low to ground by their internal discharge circuitry (DCDC1-4, and LDO1).

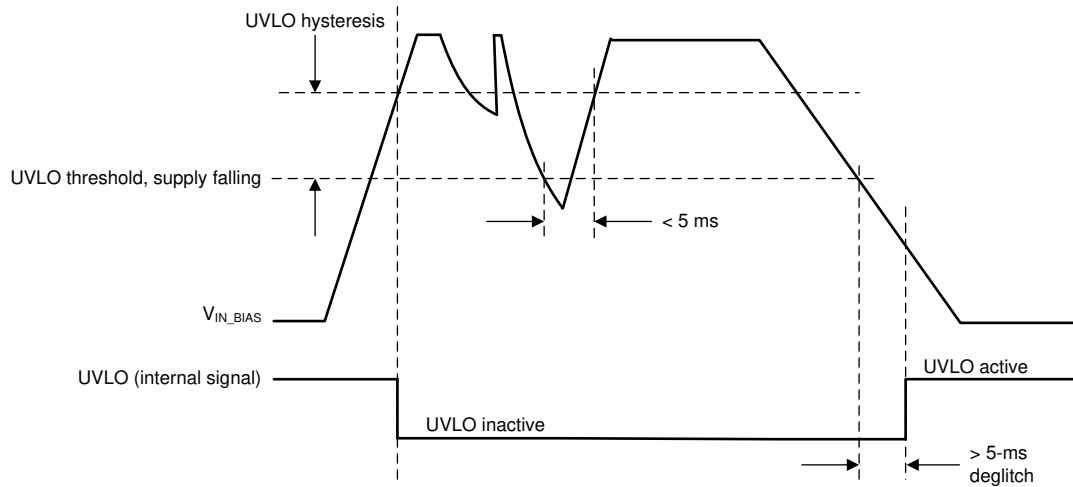

Figure 5-15. Definition of UVLO and Hysteresis

After the UVLO triggers, the internal LDO blocks current flow from its output capacitor back to the IN_BIAS pin, allowing the digital core and the discharge circuits to remain powered for a limited amount of time to properly shut-down and discharge the output rails. The hold-up time is determined by the value of the capacitor connected to INT_LDO. See [Section 5.3.1.6](#) for more details.

5.3.1.11 Power-Fail Comparator

The power-fail comparator notifies the system host if the system supply voltage drops and the system is at risk of shutting down. The comparator has an internal 800-mV threshold and the trip-point is adjusted by an external resistor divider.

By default, the power-fail comparator has no impact on any of the power rails or load switches. Load switches are configured individually, to be disabled when the PFI comparator trips to shed system load and extend hold-up time as described in Section 5.3.1.7. The power-fail comparator also triggers the power-down sequencer, such that all or selective rails power down when the system voltage fails. To tie the power-fail comparator into the power-down sequence, the OFFnPFO bit in the CONTROL register must be set to 1.

The power-fail comparator cannot be monitored by software, such that no interrupt or status bit is associated to this function.

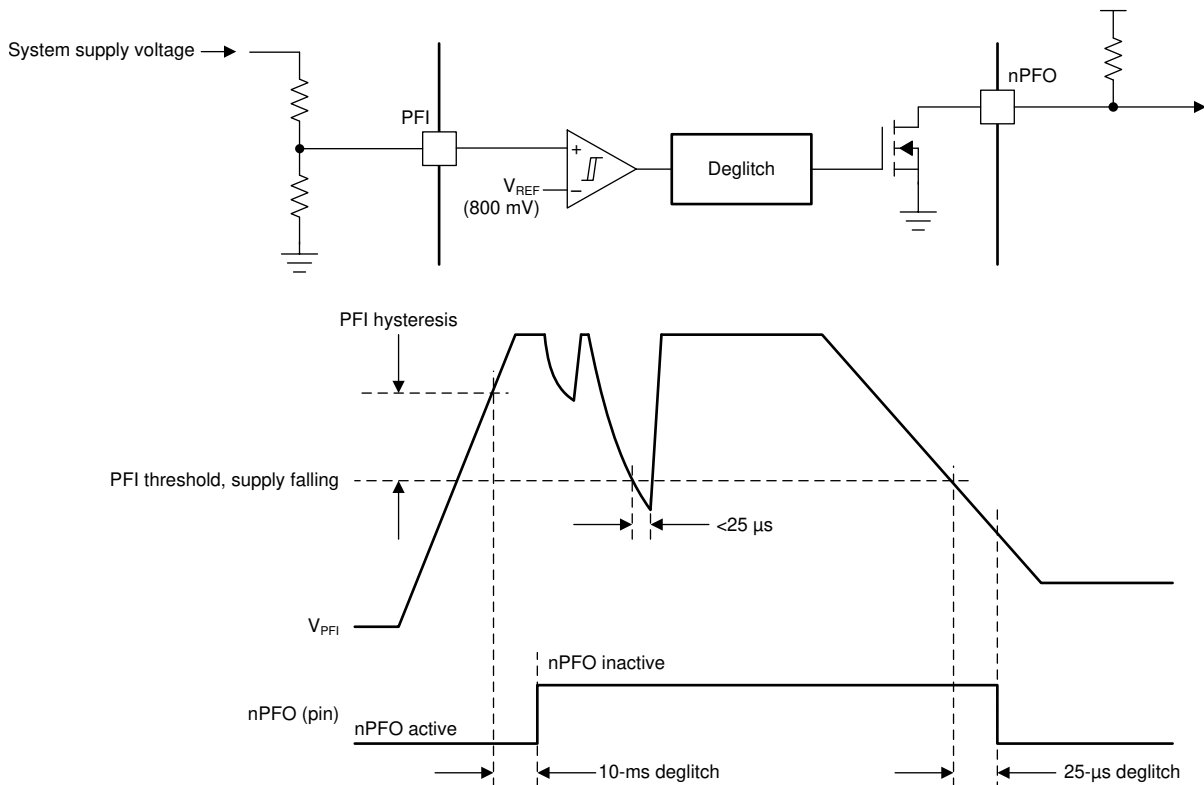

Figure 5-16. Power-Fail Comparator Simplified Circuit and Timing Diagram

5.3.1.12 Battery-Backup Supply Power-Path

DCDC5 and DCDC6 are supplied from either the CC (coin-cell battery) input or IN_BU (main system supply). The power-path is designed to prioritize IN_BU to maximize coin-cell battery life. Whenever the PMIC is powered-up (WAIT_PWR_EN, ACTIVE, SUSPEND, RECOVERY state), the power-path is forced to select the IN_BU input. In OFF mode the power-path selects the higher of the two inputs with a built-in hysteresis of 150 mV as shown in Figure 5-17.

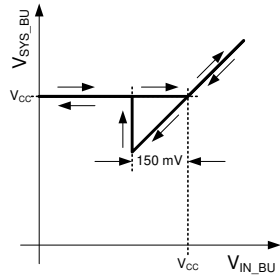

Figure 5-17. Switching Behavior of the Battery-Backup-Supply Power-Path; Power-Path Hysteresis

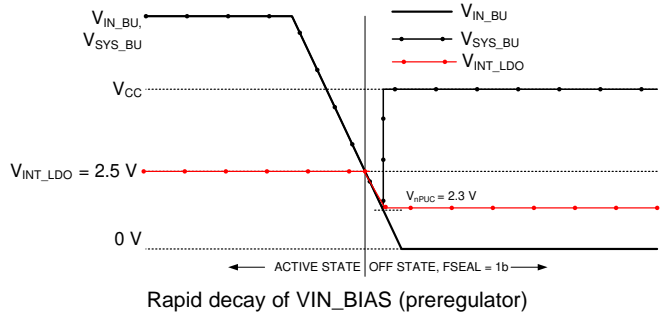

Figure 5-18. Switching Behavior of the Battery-Backup-Supply Power-Path; Main Power Supply Removal

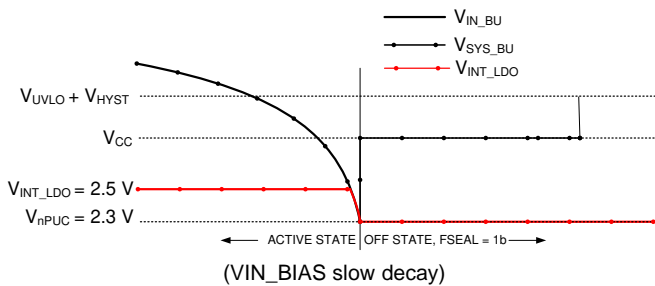

Figure 5-19. Switching Behavior of the Battery-Backup-Supply Power-Path; Weakening Main Battery, Strong Coin-Cell

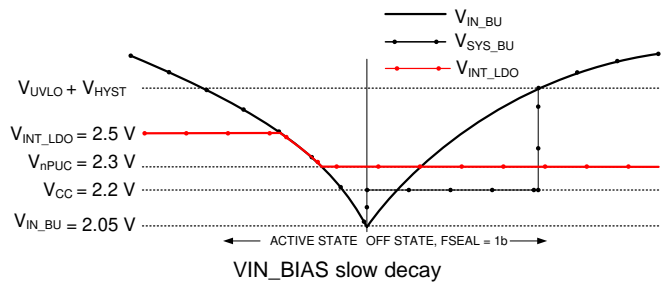

Figure 5-20. Switching Behavior of the Battery-Backup-Supply Power-Path; Weakening Main Battery, Weak Coin-Cell

When V_{IN_BIAS} drops below the UVLO threshold, the PMIC shuts down all rails and enters OFF mode. At this point the power-path selects the higher of the two input supplies. If the coin-cell battery is less than 150 mV above the UVLO threshold, SYS_BU remains connected to IN_BU (see Figure 5-19). If the coin-cell is >150 mV above the UVLO threshold, the power-path switches to the CC input as shown in Figure 5-20. With no load on the main supply, the input voltage may recover over time to a value greater than the coin-cell voltage and the power-path switches back to IN_BU. This is a typical behavior in a Li-Ion battery powered system.

Depending on the system load, V_{IN_BIAS} may drop below V_{INT_LDO} before the power-down sequence is completed. In that case, INT_LDO is turned OFF and the digital core is reset forcing the unit into OFF mode and the power-path switches to IN_BU as shown in Figure 5-18.

5.3.1.13 DCDC3 / DCDC4 Power-Up Default Selection

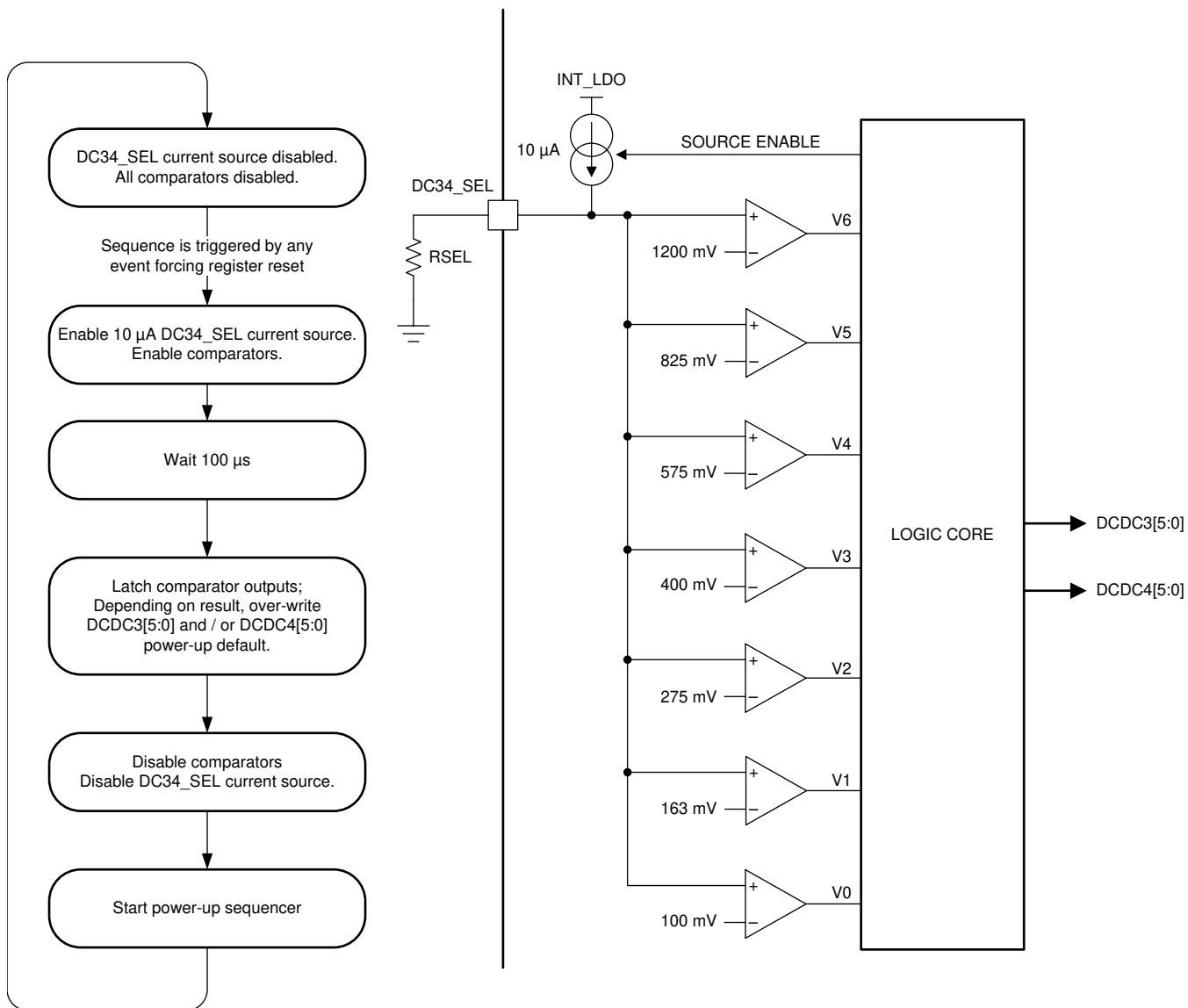

Figure 5-21. Left: Flow Chart for Selecting DCDC Power-Up Default Voltage Right: Comparator Circuit

Table 5-2. Power-Up Default Values of DCDC3 and DCDC4

RSEL [KΩ]			POWER-UP DEFAULT	
MIN	TYP	MAX	DCDC3[5:0]	DCDC4[5:0]
0	0	7.7	Programmed default (1.2 V)	Programmed default (3.3 V)
11.8	12.1	12.4	0x12 (1.35 V)	Programmed default (3.3 V)
19.5	20	20.5	0x18 (1.5 V)	Programmed default (3.3 V)
30.9	31.6	32.3	0x1F (1.8 V)	Programmed default (3.3 V)
44.4	45.3	46.3	0x3D (3.3 V)	0x01 (1.2 V)
64.8	66.1	67.3	Programmed default (1.2 V)	0x07 (1.35 V)
93.6	95.3	97.2	Programmed default (1.2 V)	0x0D (1.5 V)
146	150	Tied to INT_LDO	Programmed default (1.2 V)	0x14 (1.8 V)

5.3.1.14 I/O Configuration

The device has two GPIOs and one GPO pin which are configured as follows:

- GPIO1:
 - General-purpose, open-drain output controlled by GPO1 user bit or sequencer
 - DDR3 reset input signal from SOC. Signal is either latched or pass-through to GPO2 pin. See [Table 5-3](#) for details.
- GPO2:
 - General-purpose output controlled by GPO2 user bit
 - DDR3 reset output signal. Signal is controlled by GPIO1 and PGOOD. See [Table 5-4](#) for details.
 - Output buffer is configured as open-drain or push-pull.
- GPIO3:
 - General-purpose, open-drain output controlled by GPO3 user bit or sequencer
 - Reset input-signal for DCDC1 and DCDC2

Table 5-3. GPIO1 Configuration

IO1_SEL (EEPROM)	GPO1 (USER BIT)	PGOOD (PMIC SIGNAL)	GPIO1 (I/O PIN)	COMMENTS
0	0	X	0	Open-drain output, driving low
0	1	X	HiZ	Open-drain output, HiZ
1	X	0	X	Pin is configured as input and intended as DDR RESET signal. Coming out of POR, GPO2 is driven low. Otherwise, GPO2 status is latched at falling edge of PGOOD. See Figure 5-24 .
1	X	1	0	Pin is configured as input and intended as DDR RESET signal. GPO2 is driven low.
1	X	1	1	Pin is configured as input and intended as DDR RESET signal. GPO2 is driven high.

Table 5-4. GPO2 Configuration

IO1_SEL (EEPROM)	GPO2_BUF (EEPROM)	GPO2 (USER BIT)	COMMENTS
0	0	0	GPO2 is open drain output controlled by GPO2 user bit (driving low).
0	0	1	GPO2 is open drain output controlled by GPO2 user bit (HiZ).
0	1	0	GPO2 is push-pull output controlled by GPO2 user bit (driving low).
0	1	1	GPO2 is push-pull output controlled by GPO2 user bit (driving high).
1	0	X	GPO2 is open drain output controlled by GPIO1/PGOOD.
1	1	X	GPO2 is push-pull output controlled by GPIO1/PGOOD.

Table 5-5. GPIO3 Configuration

DC12_RST (EEPROM)	GPO3 (USER BIT)	GPIO3 (I/O PIN)	COMMENTS
0	0	0	Open-drain output, driving low
0	1	HiZ	Open-drain output, HiZ
1	X	Active low	GPIO3 is DCDC1 and DCDC2 reset input signal to PMIC (active low). See Section 5.3.1.14.2 for details.

5.3.1.14.1 Configuring GPO2 as Open-Drain Output

GPO2 may be configured as open-drain or push-pull output. The supply for the push-pull driver is internally connected to the IN_LS1 input pin, whereas an external pullup resistor and supply are required in the open-drain configuration. Because of the internal connection to IN_LS1, the external pullup supply must not exceed the voltage on the IN_LS1 pin, otherwise leakage current may be observed from GPO2 to IN_LS1 as shown in Figure 5-22.

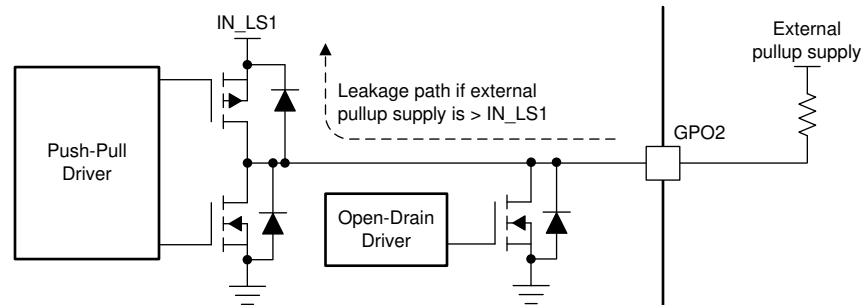

Figure 5-22. GPO2 as Open-Drain Output

NOTE

When configured as open-drain output, the external pullup supply must not exceed the voltage level on IN_LS1 pin.

5.3.1.14.2 Using GPIO3 as Reset Signal to DCDC1 and DCDC2

With the DC12_RST bit set to 1, GPIO3 is an edge-sensitive reset input to the PMIC. The reset signal affects DCDC1 and DCDC2 only, so that only those two registers are reset to the power-up default whenever GPIO3 input transitions from high to low, while all other registers maintain their current values. DCDC1 and DCDC2 transition back to the default value following the SLEW settings, and are not power cycled. This function recovers the processor from reset events while in low-power mode.

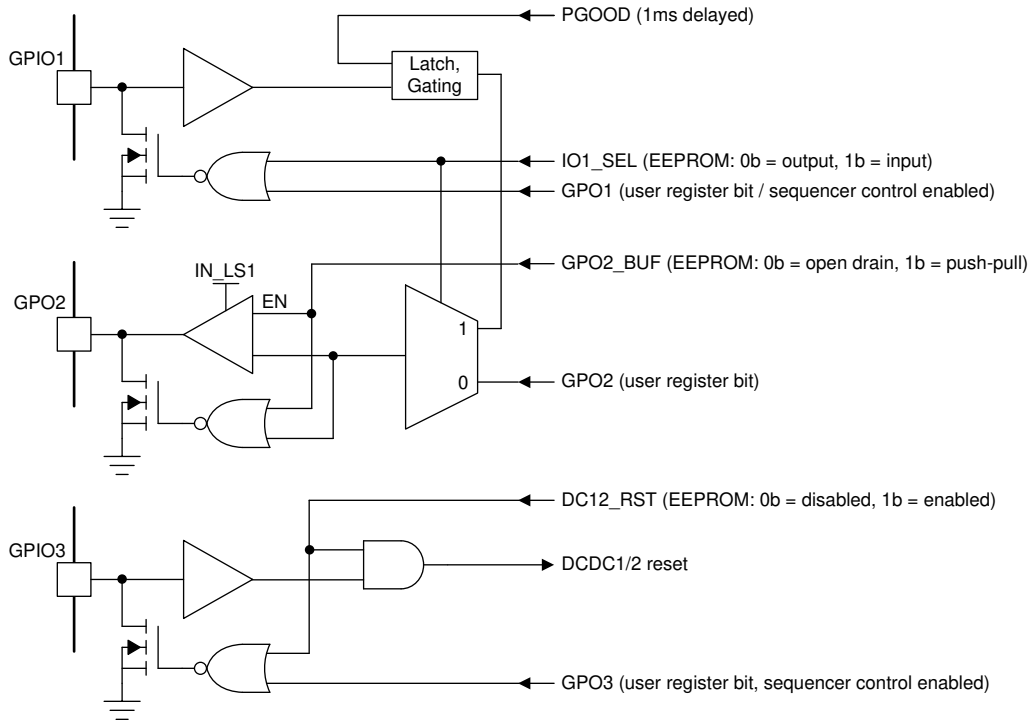

Figure 5-23. I/O Pin Logic

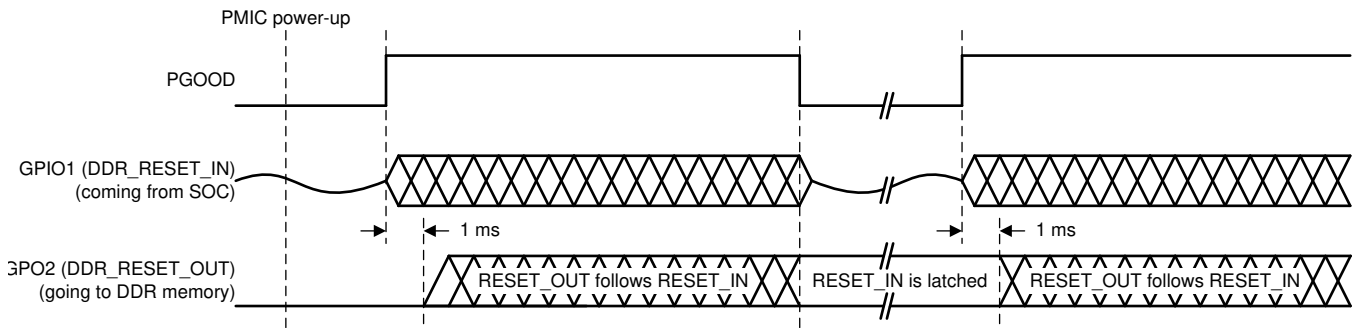

Figure 5-24. DDR3 Reset Timing Diagram

NOTE

GPIO must be configured as input (IO1_SEL = 1b). GPO2 is automatically configured as output.

5.3.1.15 Push Button Input (PB)

The PB pin is a CMOS-type input used to power-up the PMIC. Typically, the PB pin is connected to a momentary switch to ground and an external pullup resistor. The power-up sequence is triggered if the PB input is held low for 600 ms.

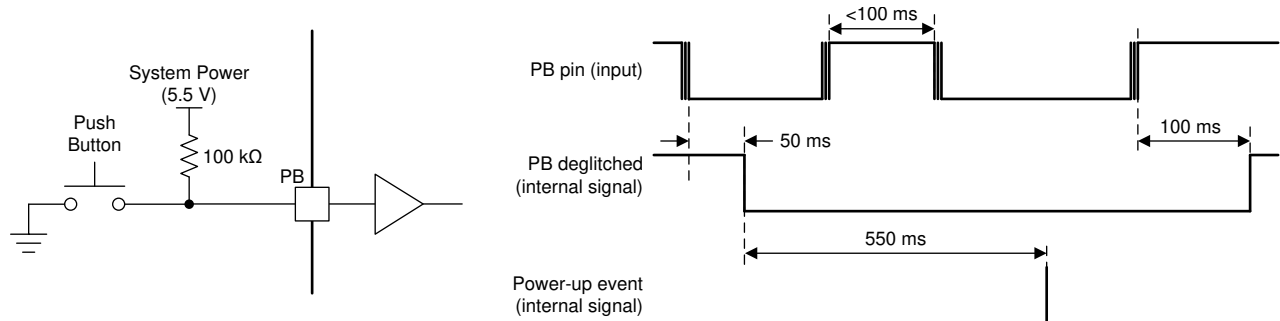

**Figure 5-25. Left: Typical PB Input Circuit
Right: Push-Button Input (PB) Deglitch and Power-Up Timing**

In ACTIVE mode, the TPS65218D0 monitors the PB input and issues an interrupt when the pin status changes, such as when it drops below or rises above the PB input-low or input-high thresholds. The interrupt is masked by the PBM bit in the INT_MASK1 register.

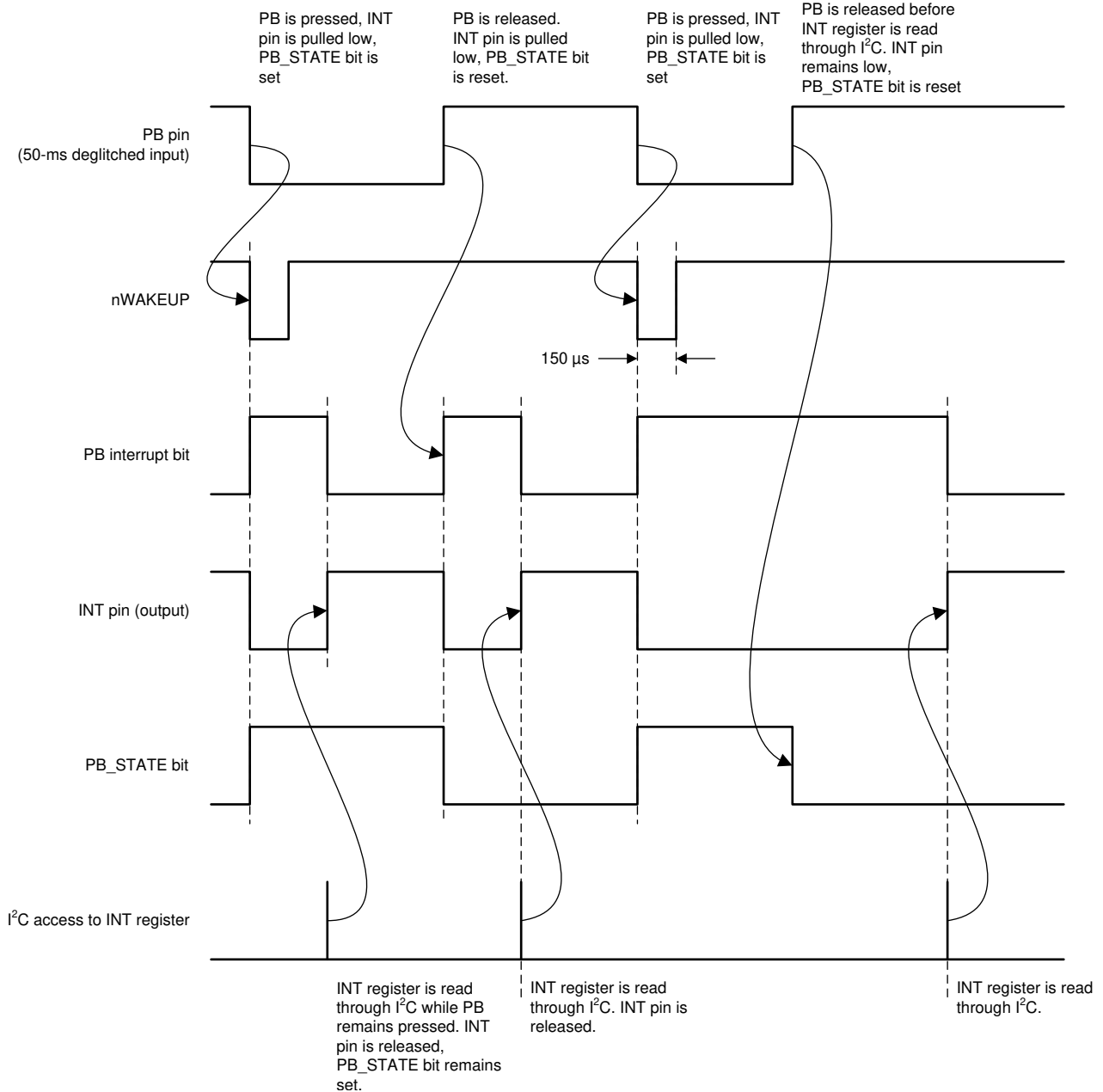

Figure 5-26. PB Input-Low or Input-High Thresholds

NOTE

Interrupts are issued whenever the PB pin status changes. The PB_STATE bit reflects the current status of the PB input. nWAKEUP is pulled low for 150 μs on every falling edge of PB.

5.3.1.15.1 Signaling PB-Low Event on the nWAKEUP Pin

In ACTIVE state, the nWAKEUP pin is pulled low for five 32-kHz clock cycles (approximately 150 μ s) whenever a falling edge on the PB input is detected. This allows the host processor to wakeup from DEEP SLEEP mode of operation. It is recommended to pull-up the nWAKEUP pin to DCDC6 output through a 1-M Ω resistor.

5.3.1.15.2 Push Button Reset

If the PB input is pulled low for 8 s (15 s if TRST = 1b) or longer, all rails except for DCDC5 and DCDC6 are disabled, and the device enters the RECOVERY state. The device powers up automatically after the 500 ms power-down sequence is complete, regardless of the state of the PB input. Holding the PB pin low for 8 s (15 s if TRST = 1b), only turns off the device temporarily and forces a system restart, and is not a power-down function. If the PB is held low continuously, the device power-cycles in 8-s and 15-s intervals.

5.3.1.16 AC_DET Input (AC_DET)

The AC_DET pin is a CMOS-type input used in three different ways to control the power-up of the PMIC:

- In a battery operated system, AC_DET is typically connected to an external battery charger with an open-drain power-good output pulled low when a valid charger supply is connected to the system. A falling edge on the AC_DET pin causes the PMIC to power up.
- In a non-portable system, the AC_DET pin may be shorted to ground and the IC powers up whenever system power is applied to the chip.
- If none of the above behaviors are desired, AC_DET may be tied to system power (IN_BIAS). Power-up is then controlled through the push-button input or PWR_EN input.

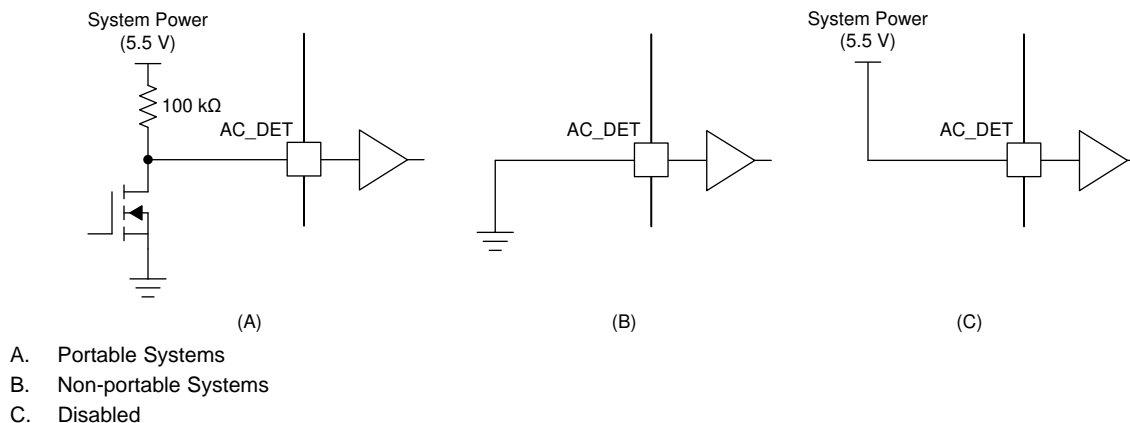

Figure 5-27. AC_DET Pin Configurations

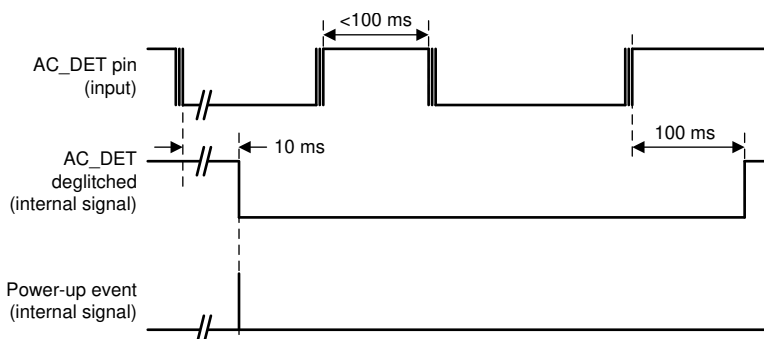

Figure 5-28. AC_DET Input Deglitch and Power-Up Timing (Portable Systems)

In ACTIVE state, the TPS65218D0 monitors the AC_DET input and issues an interrupt when the pin status changes, such as when it drops below or rises above the AC_DET input-low or input-high thresholds. The interrupt is masked by the ACM bit in the INT_MASK1 register.

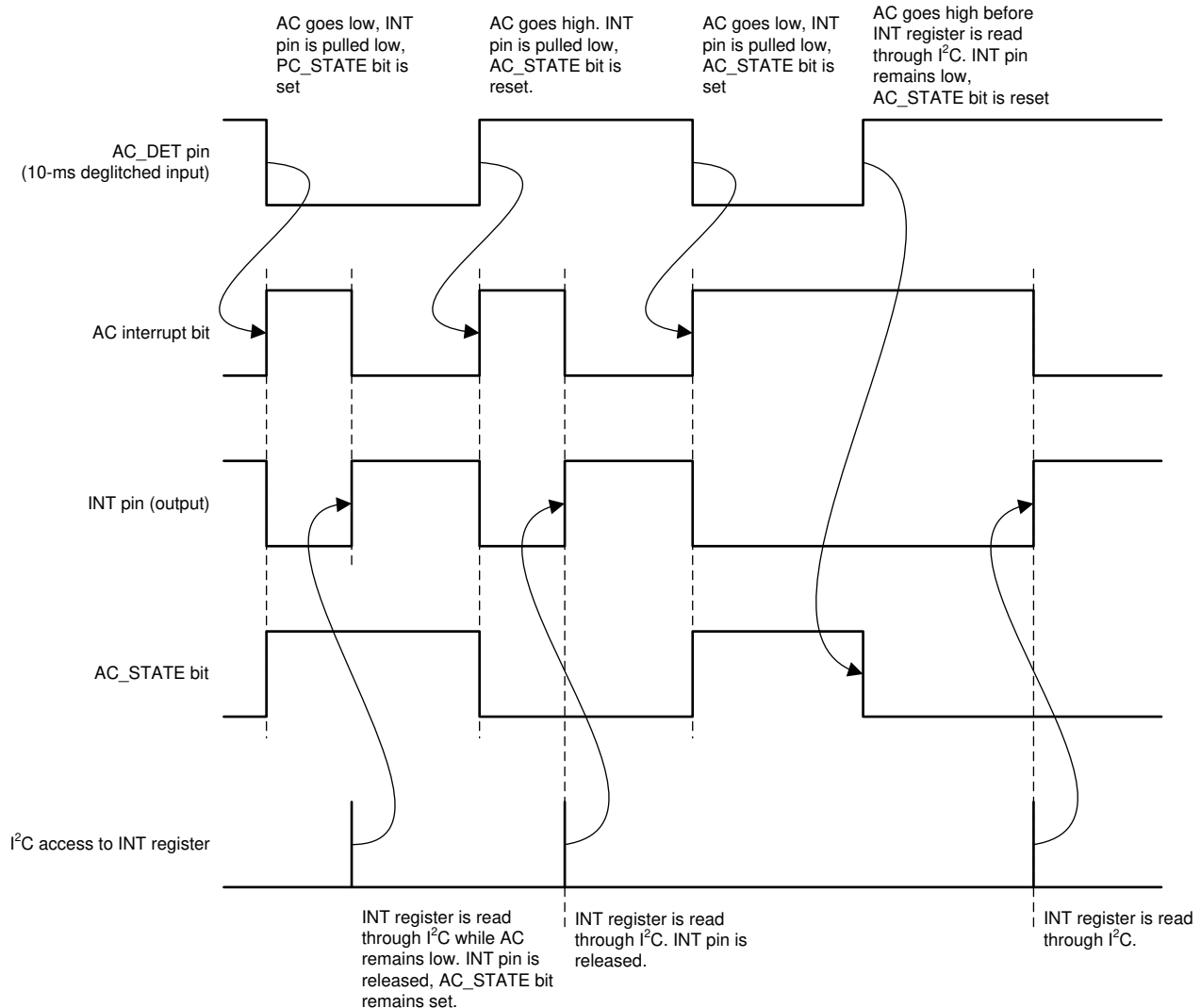

Figure 5-29. AC_STATE Pin

NOTE

Interrupts are issued whenever the AC_DET pin status changes. The AC_STATE bit reflects the current status of the AC_DET input.

5.3.1.17 Interrupt Pin (INT)

The interrupt pin signals any event or fault condition to the host processor. Whenever a fault or event occurs in the IC, the corresponding interrupt bit is set in the INT register, and the open-drain output is pulled low. The INT pin is released (returns to Hi-Z state) and fault bits are cleared when the host reads the INT register. If a failure persists, the corresponding INT bit remains set and the INT pin is pulled low again after a maximum of 32 μ s.

The MASK register masks events from generating interrupts. The MASK settings affect the INT pin only, and have no impact on the protection and monitor circuits.

5.3.1.18 I²C Bus Operation

The TPS65218D0 hosts a slave I²C interface (address 0x24) that supports data rates up to 400kbps, auto-increment addressing. ⁽¹⁾

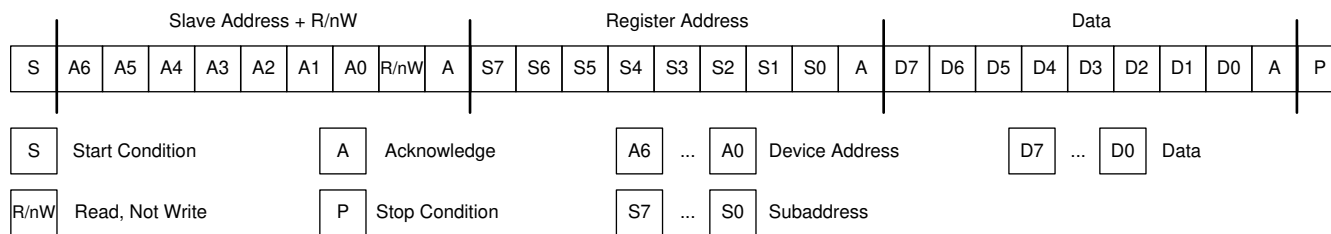

Figure 5-30. Subaddress in I²C Transmission

The I²C bus is a communications link between a controller and a series of slave terminals. The link is established using a two-wired bus consisting of a serial clock signal (SCL) and a serial data signal (SDA). The serial clock is sourced from the controller in all cases where the serial data line is bi-directional for data communication between the controller and the slave terminals. Each device has an open drain output to transmit data on the serial data line. An external pullup resistor must be placed on the serial data line to pull the drain output high during data transmission.

Data transmission initiates with a start bit from the controller as shown in Figure 5-32. The start condition is recognized when the SDA line transitions from high to low during the high portion of the SCL signal. Upon reception of a start bit, the device receives serial data on the SDA input and checks for valid address and control information. If the appropriate slave address is set for the device, the device issues an acknowledge pulse and prepares to receive register address and data. Data transmission is completed by either the reception of a stop condition or the reception of the data word sent to the device. A stop condition is recognized as a low to high transition of the SDA input during the high portion of the SCL signal. All other transitions of the SDA line must occur during the low portion of the SCL signal. An acknowledge issues after the reception of valid slave address, register-address, and data words. The I²C interfaces auto-sequence through register addresses, so that multiple data words can be sent for a given I²C transmission. Reference Figure 5-31 and Figure 5-32 for details.

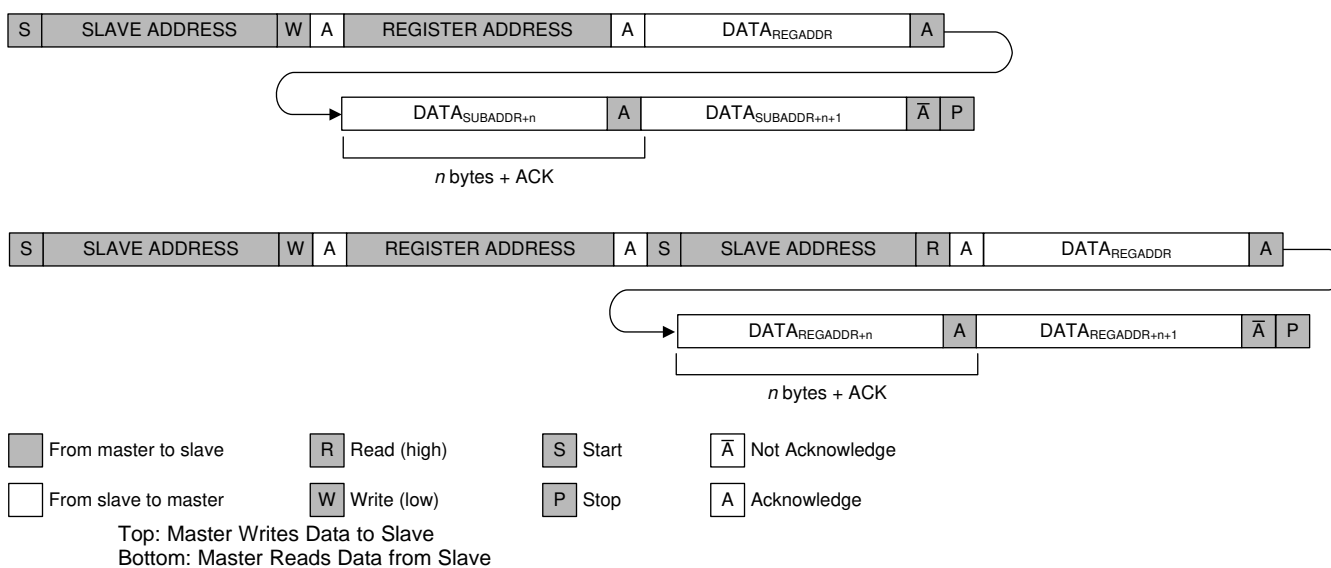

Figure 5-31. I²C Data Protocol

(1) Note: The SCL duty cycle at 400 kHz must be >40%.

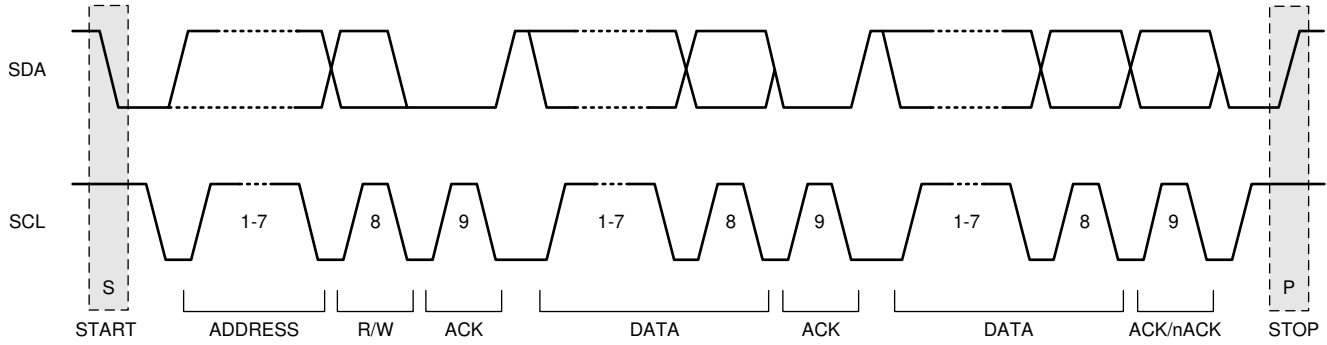

Figure 5-32. I²C Protocol and Transmission Timing; I²C Start/Stop/Acknowledge Protocol

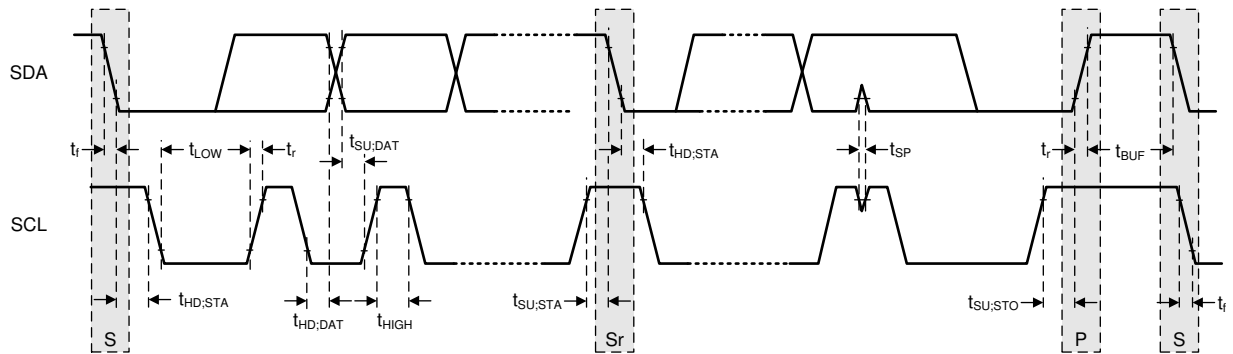
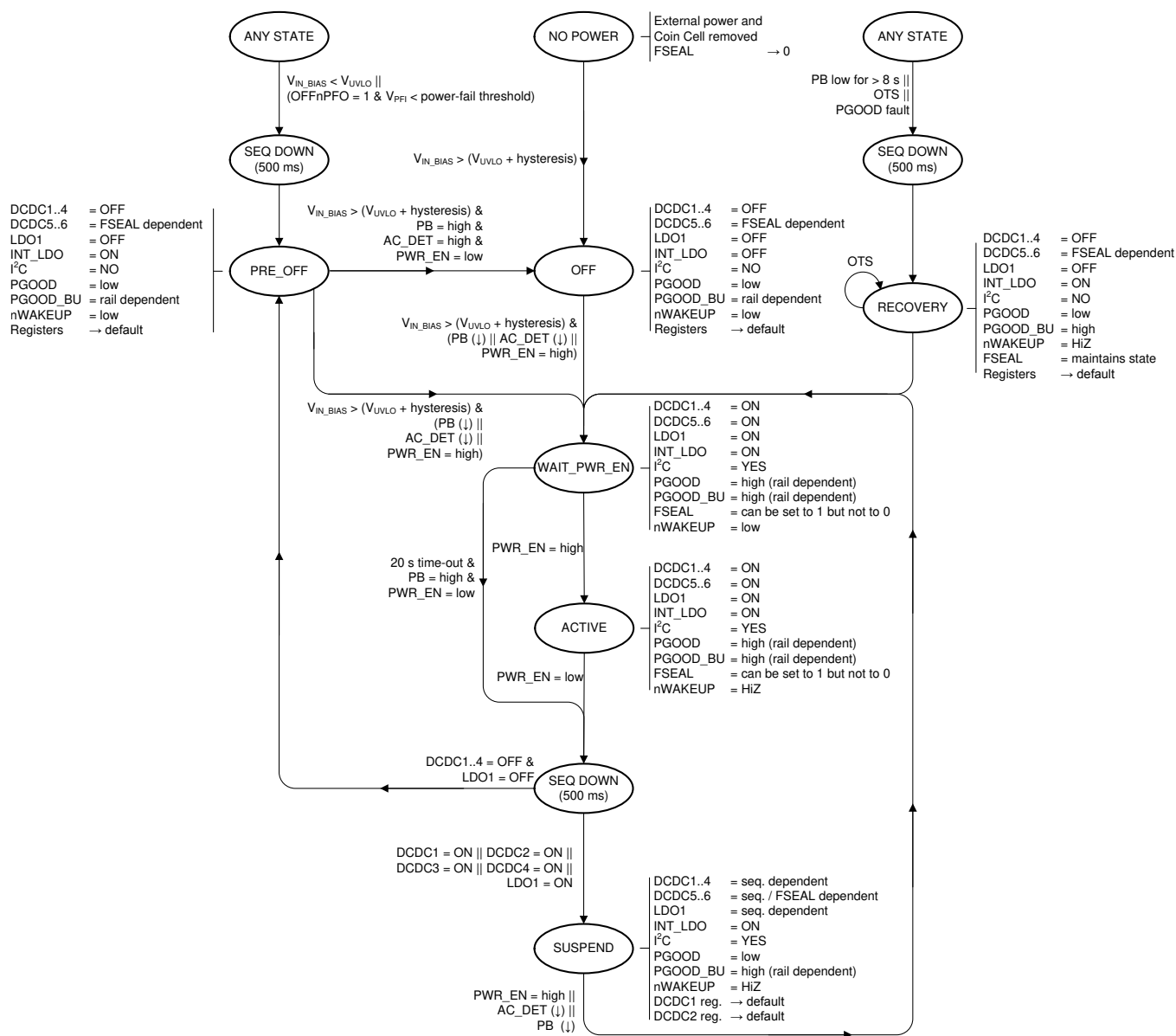

Figure 5-33. I²C Protocol and Transmission Timing; I²C Data Transmission Timing

5.4 Device Functional Modes

5.4.1 Modes of Operation



PB (↓) has 50 ms debounce.
 AC_DET (↓) has 10 ms debounce.
 (↓) = denotes falling edge of signal.

Figure 5-34. Modes of Operation Diagram

5.4.2 OFF

In OFF mode, the PMIC is completely shut down with the exception of a few circuits to monitor the AC_DET, PWR_EN and PB input. All power rails are turned off and the registers are reset to their default values. The I^2C communication interface is turned off. This is the lowest-power mode of operation. To exit OFF mode V_{IN_BIAS} must exceed the UVLO threshold and one of the following wake-up events must occur:

- The PB input is pulled low.
- THE AC_DET input is pulled low.
- The PWR_EN input is pulled high.

To enter OFF state, ensure all power rails are assigned to the sequencer, then pull the PWR_EN pin low. Additionally, if the OFFnPFO bit is set to 1b and the PFI input falls below the power fail threshold the device transitions to the OFF state. If the freshness seal is broken, DCDC5 and DCDC6 remains on in the OFF state.

If a PGOOD or OTS fault occurs while in the ACTIVE state, TPS65218D0 will transition to the RESET state.

5.4.3 ACTIVE

This is the typical mode of operation when the system is up and running. All DCDC converters, LDOs, and load switches are operational and can be controlled through the I²C interface. After a wake-up event, the PMIC enables all rails controlled by the sequencer and pulls the nWAKEUP pin low to signal the event to the host processor. The device only enters ACTIVE state if the host asserts the PWR_EN pin within 20 s after the wake-up event. Otherwise it will enter OFF state. The nWAKEUP pin returns to HiZ mode after the PWR_EN pin is asserted. ACTIVE state can also be directly entered from SUSPEND state by pulling the PWR_EN pin high. See SUSPEND state description for details. To exit ACTIVE mode, the PWR_EN pin must be pulled low.

5.4.4 SUSPEND

SUSPEND state is a low-power mode of operation intended to support system standby. Typically all power rails are turned off with the exception of any rail with an SEQ register set to 0h. DCDC5 and DCDC6 also remain enabled if the freshness seal is broken. To enter SUSPEND state, pull the PWR_EN pin low. All power rails controlled by the power-down sequencer are shut down, and after 500 ms the device enters SUSPEND state. All rails not controlled by the power-down sequencer will maintain state. Note that all register values are reset as the device enters the SUSPEND state. The device enters ACTIVE state after it detects a wake-up event as described in the previous sections.

5.4.5 RESET

The TPS65218D0 can be reset by holding the PB pin low for more than 8 or 15 s, depending on the value of the TRST bit. All rails are shut down by the sequencer and all register values reset to their default values. Rails not controlled by the sequencer are shut down additionally. Note that the RESET function power-cycles the device and only temporarily shuts down the output rails. Resetting the device does not lead to OFF state. If the PB_IN pin is kept low for an extended amount of time, the device continues to cycle between ACTIVE and RESET state, entering RESET every 8 or 15 s.

The device is also reset if a PGOOD or OTS fault occurs. The TPS65218D0 remains in the recovery state until the fault is removed, at which time it transitions back to the ACTIVE state.

5.5 Programming

5.5.1 Programming Power-Up Default Values

A consecutive write of 0x50, 0x1A, or 0xCE to the password register commits the current register settings to EEPROM memory so they become the new power-up default values.

NOTE

Only bits marked with (E2) in the register map have EEPROM programmable power-up default settings. All other bits keep the factory settings listed in the register map. Changing the power-up default values is not recommended in production but for prototyping only.

The EEPROM of a device can only be programmed up to 1000 times. The number of programming cycles should never exceed this amount. Contact TI for changing production settings.

EEPROM values can only be changed if the input voltage (VIN_BIAS) is greater than 4.5 V. If the input voltage is less than 4.5 V, EEPROM values remain unchanged and the VPROG interrupt is issued. EEPROM programming requires less than 100 ms. During this time the supply voltage must be held constant and all I²C write commands are ignored. Completion of EEPROM programming is signaled by the EE_CMPL interrupt.

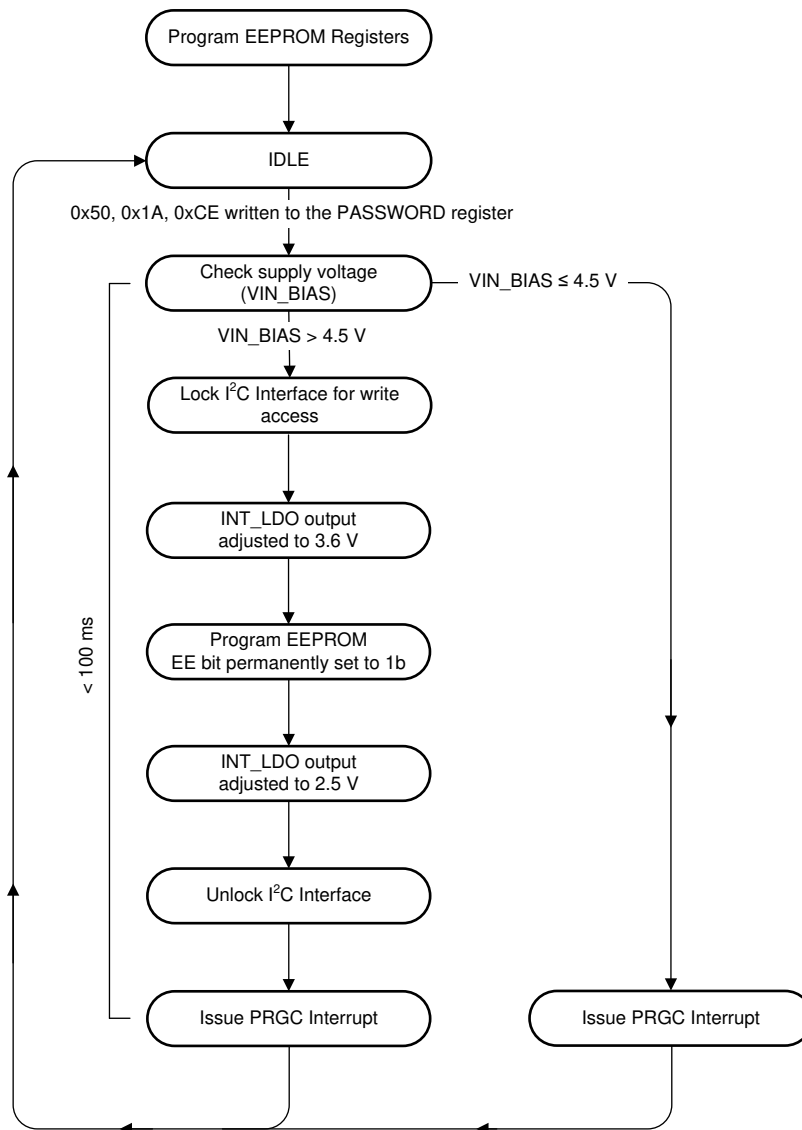

Figure 5-35. Flow Chart for Programming New Power-Up Default Values

NOTE

All re-programmed EEPROM settings must be validated during prototyping phase to ensure desired functionality because parts cannot be returned in case of incorrect programming. Any issues should be reported to the [e2e forum](#).

5.6 Register Maps

5.6.1 Password Protection

Registers 0x11h through 0x26h are protected against accidental write by a 8-bit password. The password must be written prior to writing to a protected register and automatically resets to 0x00h after the next I²C transaction, regardless of the register accessed or transaction type (read or write). The password is required for write access only and is not required for read access.

To write to a protected register:

1. Write the address of the destination register, XORed with the protection password (0x7Dh), to the PASSWORD register (0x10h).
2. Write the data to the password protected register.
3. If the content of the PASSWORD register XORed with the address send matches 0x7Dh, the data transfers to the protected register. Otherwise, the transaction is ignored. In either case the PASSWORD register resets to 0x00 after the transaction.

The cycle must be repeated for any other register that is Level1 write protected.

5.6.2 Freshness Seal (FSEAL) Bit

The FSEAL (freshness seal) bit prevents accidental shut-down of the always-on supplies, DCDC5 and DCDC6. The FSEAL bit exists in a default state of 0, and can be set to 1 and reset to 0 once for factory testing. The second time the bit is set to 1, it remains 1 and cannot reset again under software control. Coin-cell battery and main supply must be disconnected from the IC to reset the FSEAL bit again. With the FSEAL bit set to 1, DCDC5 and DCDC6 are forced ON regardless of the state of the DC5_EN and DC6_EN bit, and the rails do not turn off when the IC enters OFF mode.

A consecutive write of [0xB1, 0xFE, 0xA3] to the password register sets the FSEAL bit to 1. The three bytes must be written consecutively for the sequence to be valid. No other read or write transactions are allowed between the three bytes, or the sequence is invalid. After a valid sequence, the FSEAL bit in the STATUS register reflects the new setting.

After setting the FSEAL bit, the IC can enter OFF or any other mode of operation without affecting the state of the FSEAL bit, provided the coin-cell supply remains connected to the chip.

A second write of [0xB1, 0xFE, 0xA3] to the password register resets the FSEAL bit to 0. The three bytes must be written consecutively for the sequence to be valid.

A third write of [0xB1, 0xFE, 0xA3] to the password register sets the FSEAL bit to 1 and locks it into this state for as long as the coin-cell supply (CC) remains connected to the chip.

5.6.3 FLAG Register

The FLAG register contains a bit for each power rail and GPO to keep track of the enable state of the rails while the system is suspended. The following rules apply to the FLAG register:

- The power-up default value for any flag bit is 0.
- Flag bits are read-only and cannot be written to.
- Upon entering a SUSPEND state, the flag bits are set to same value as their corresponding ENABLE bits. Rails and GPOs enabled in a SUSPEND state have flag bits set to 1, while all other flag bits are set to 0. Flag bits are not updated while in the SUSPEND state or when exiting the SUSPEND state.
- The FLAG register is static in WAIT_PWR_EN and ACTIVE state. The FLAG register reflects the enable state of DCDC1, 2, 3, 4, LDO1, and GPO1, 2, 3 during the last SUSPEND state.

The host processor reads the FLAG register to determine if the system powered up from the OFF or SUSPEND state. In the SUSPEND state, typically the DDR memory is kept in self refresh mode and therefore the DC3_FLG or DC4_FLG bits are set.

5.6.4 TPS65218D0 Registers

Table 5-6 lists the memory-mapped registers for the TPS65218D0. All register offset addresses not listed in Table 5-6 should be considered as reserved locations and the register contents should not be modified.

Table 5-6. TPS65218D0 Registers

SUBADDRESS	ACRONYM	REGISTER NAME	R/W	PASSWORD PROTECTED	SECTION
0x0	CHIPID	CHIP ID	R	No	Go
0x1	INT1	INTERRUPT 1	R	No	Go
0x2	INT2	INTERRUPT 2	R	No	Go
0x3	INT_MASK1	INTERRUPT MASK 1	R/W	No	Go
0x4	INT_MASK2	INTERRUPT MASK 2	R/W	No	Go
0x5	STATUS	STATUS	R	No	Go
0x6	CONTROL	CONTROL	R/W	No	Go
0x7	FLAG	FLAG	R	No	Go
0x10	PASSWORD	PASSWORD	R/W	No	Go
0x11	ENABLE1	ENABLE 1	R/W	Yes	Go
0x12	ENABLE2	ENABLE 2	R/W	Yes	Go
0x13	CONFIG1	CONFIGURATION 1	R/W	Yes	Go
0x14	CONFIG2	CONFIGURATION 2	R/W	Yes	Go
0x15	CONFIG3	CONFIGURATION 3	R/W	Yes	Go
0x16	DCDC1	DCDC1 CONTROL	R/W	Yes	Go
0x17	DCDC2	DCDC2 CONTROL	R/W	Yes	Go
0x18	DCDC3	DCDC3 CONTROL	R/W	Yes	Go
0x19	DCDC4	DCDC4 CONTROL	R/W	Yes	Go
0x1A	SLEW	SLEW RATE CONTROL	R/W	Yes	Go
0x1B	LDO1	LDO1 CONTROL	R/W	Yes	Go
0x20	SEQ1	SEQUENCER 1	R/W	Yes	Go
0x21	SEQ2	SEQUENCER 2	R/W	Yes	Go
0x22	SEQ3	SEQUENCER 3	R/W	Yes	Go
0x23	SEQ4	SEQUENCER 4	R/W	Yes	Go
0x24	SEQ5	SEQUENCER 5	R/W	Yes	Go
0x25	SEQ6	SEQUENCER 6	R/W	Yes	Go
0x26	SEQ7	SEQUENCER 7	R/W	Yes	Go

Table 5-7 explains the common abbreviations used in this section.

Table 5-7. Common Abbreviations

Abbreviation	Description
R	Read
W	Write
R/W	Read and write capable
E2	Backed by EEPROM
h	Hexadecimal notation of a group of bits
b	Hexadecimal notation of a bit or group of bits
X	Don't care reset value

5.6.4.1 CHIPID Register (subaddress = 0x0) [reset = 0x5]

CHIPID is shown in [Figure 5-36](#) and described in [Table 5-8](#).

Return to [Summary Table](#).

Figure 5-36. CHIPID Register

7	6	5	4	3	2	1	0
CHIP					REV		
R-0h					R-5h		

Table 5-8. CHIPID Register Field Descriptions

Bit	Field	Type	Reset	Description
7-3	CHIP	R	0h	Chip ID 0h = TPS65218D0 1h = Future use ... 1Fh = Future use
2-0	REV	R	5h	Revision code 0h = Revision 1.0 1h = Revision 1.1 2h = Revision 2.0 3h = Revision 2.1 4h = Revision 3.0 5h = Revision 4.0 (D0) 6h = Future use 7h = Future use

5.6.4.2 INT1 Register (subaddress = 0x1) [reset = 0x0]

INT1 is shown in [Figure 5-37](#) and described in [Table 5-9](#).

Return to [Summary Table](#).

Figure 5-37. INT1 Register

7	6	5	4	3	2	1	0
RESERVED		VPRG	AC	PB	HOT	CC_AQC	PRGC
R-0h		R-0b	R-0b	R-0b	R-0b	R-0b	R-0b

Table 5-9. INT1 Register Field Descriptions

Bit	Field	Type	Reset	Description
7-6	RESERVED	R	0h	
5	VPRG	R	0b	Programming voltage interrupt 0b = No significance 1b = Input voltage is too low for programming power-up default values.
4	AC	R	0b	AC_DET pin status change interrupt. Note: Status information is available in STATUS register 0b = No change in status 1b = AC_DET status change (AC_DET pin changed high to low or low to high)
3	PB	R	0b	Push-button status change interrupt. Note: Status information is available in STATUS register 0b = No change in status 1b = Push-button status change (PB changed high to low or low to high)
2	HOT	R	0b	Thermal shutdown early warning 0b = Chip temperature is below HOT threshold 1b = Chip temperature exceeds HOT threshold
1	CC_AQC	R	0b	Coin cell battery voltage acquisition complete interrupt 0b = No significance 1b = Backup battery status comparators have settled and results are available in STATUS register
0	PRGC	R	0b	EEPROM programming complete interrupt 0b = No significance 1b = Programming of power-up default settings has completed successfully

5.6.4.3 INT2 Register (subaddress = 0x2) [reset = 0x0]

INT2 is shown in [Figure 5-38](#) and described in [Table 5-10](#).

Return to [Summary Table](#).

Figure 5-38. INT2 Register

7	6	5	4	3	2	1	0
RESERVED		LS3_F	LS2_F	LS1_F	LS3_I	LS2_I	LS1_I
R-0h		R-0b	R-0b	R-0b	R-0b	R-0b	R-0b

Table 5-10. INT2 Register Field Descriptions

Bit	Field	Type	Reset	Description
7-6	RESERVED	R	0h	
5	LS3_F	R	0b	Load switch 3 fault interrupt 0b = No fault. Switch is working normally. 1b = Load switch exceeded operating temperature limit and is temporarily disabled.
4	LS2_F	R	0b	Load switch 2 fault interrupt 0b = No fault. Switch is working normally. 1b = Load switch exceeded operating temperature limit or input voltage dropped below minimum value. Switch is temporarily disabled.
3	LS1_F	R	0b	Load switch 1 fault interrupt 0b = No fault. Switch is working normally. 1b = Load switch exceeded operating temperature limit and is temporarily disabled.
2	LS3_I	R	0b	Load switch 3 current-limit interrupt 0b = Load switch is disabled or not in current limit 1b = Load switch is actively limiting the output current (output load is exceeding current limit value)
1	LS2_I	R	0b	Load switch 2 current-limit interrupt 0b = Load switch is disabled or not in current limit 1b = Load switch is actively limiting the output current (output load is exceeding current limit value)
0	LS1_I	R	0b	Load switch 1 current-limit interrupt 0b = Load switch is disabled or not in current limit 1b = Load switch is actively limiting the output current (output load is exceeding current limit value)

5.6.4.4 INT_MASK1 Register (subaddress = 0x3) [reset = 0x0]

INT_MASK1 is shown in [Figure 5-39](#) and described in [Table 5-11](#).

Return to [Summary Table](#).

Figure 5-39. INT_MASK1 Register

7	6	5	4	3	2	1	0
RESERVED	VPRGM	ACM	PBM	HOTM	CC_AQCM	PRGCM	
R-0h	R/W-0b	R/W-0b	R/W-0b	R/W-0b	R/W-0b	R/W-0b	R/W-0b

Table 5-11. INT_MASK1 Register Field Descriptions

Bit	Field	Type	Reset	Description
7-6	RESERVED	R	0h	
5	VPRGM	R/W	0b	Programming voltage interrupt mask bit. Note: mask bit has no effect on monitoring function 0b = Interrupt is unmasked (interrupt event pulls nINT pin low) 1b = Interrupt is masked (interrupt has no effect on nINT pin)
4	ACM	R/W	0b	AC_DET interrupt masking bit. 0b = Interrupt is unmasked (interrupt event pulls nINT pin low) 1b = Interrupt is masked (interrupt has no effect on nINT pin) Note: mask bit has no effect on monitoring function
3	PBM	R/W	0b	PB interrupt masking bit. Note: mask bit has no effect on monitoring function 0b = Interrupt is unmasked (interrupt event pulls nINT pin low) 1b = Interrupt is masked (interrupt has no effect on nINT pin)
2	HOTM	R/W	0b	HOT interrupt masking bit. Note: mask bit has no effect on monitoring function 0b = Interrupt is unmasked (interrupt event pulls nINT pin low) 1b = Interrupt is masked (interrupt has no effect on nINT pin)
1	CC_AQCM	R/W	0b	C_AQC interrupt masking bit. Note: mask bit has no effect on monitoring function 0b = Interrupt is unmasked (interrupt event pulls nINT pin low) 1b = Interrupt is masked (interrupt has no effect on nINT pin)
0	PRGCM	R/W	0b	PRGC interrupt masking bit. Note: mask bit has no effect on monitoring function 0b = Interrupt is unmasked (interrupt event pulls nINT pin low) 1b = Interrupt is masked (interrupt has no effect on nINT pin)

5.6.4.5 INT_MASK2 Register (subaddress = 0x4) [reset = 0x0]

INT_MASK2 is shown in [Figure 5-40](#) and described in [Table 5-12](#).

Return to [Summary Table](#).

Figure 5-40. INT_MASK2 Register

7	6	5	4	3	2	1	0
RESERVED		LS3_FM	LS2_FM	LS1_FM	LS3_IM	LS2_IM	LS1_IM
R-0h		R/W-0b	R/W-0b	R/W-0b	R/W-0b	R/W-0b	R/W-0b

Table 5-12. INT_MASK2 Register Field Descriptions

Bit	Field	Type	Reset	Description
7-6	RESERVED	R	0h	
5	LS3_FM	R/W	0b	LS3 fault interrupt mask bit. Note: mask bit has no effect on monitoring function 0b = Interrupt is unmasked (interrupt event pulls nINT pin low) 1b = Interrupt is masked (interrupt has no effect on nINT pin)
4	LS2_FM	R/W	0b	LS2 fault interrupt mask bit. Note: mask bit has no effect on monitoring function 0b = Interrupt is unmasked (interrupt event pulls nINT pin low) 1b = Interrupt is masked (interrupt has no effect on nINT pin)
3	LS1_FM	R/W	0b	LS1 fault interrupt mask bit. Note: mask bit has no effect on monitoring function 0b = Interrupt is unmasked (interrupt event pulls nINT pin low) 1b = Interrupt is masked (interrupt has no effect on nINT pin)
2	LS3_IM	R/W	0b	LS3 current-limit interrupt mask bit. Note: mask bit has no effect on monitoring function 0b = Interrupt is unmasked (interrupt event pulls nINT pin low) 1b = Interrupt is masked (interrupt has no effect on nINT pin)
1	LS2_IM	R/W	0b	LS2 current-limit interrupt mask bit. Note: mask bit has no effect on monitoring function 0b = Interrupt is unmasked (interrupt event pulls nINT pin low) 1b = Interrupt is masked (interrupt has no effect on nINT pin)
0	LS1_IM	R/W	0b	LS1 current-limit interrupt mask bit. Note: mask bit has no effect on monitoring function 0b = Interrupt is unmasked (interrupt event pulls nINT pin low) 1b = Interrupt is masked (interrupt has no effect on nINT pin)

5.6.4.6 STATUS Register (subaddress = 0x5) [reset = 00XXXXXXb]

Register mask: C0h

STATUS is shown in [Figure 5-41](#) and described in [Table 5-13](#).

Return to [Summary Table](#).

Figure 5-41. STATUS Register

7	6	5	4	3	2	1	0
FSEAL	EE	AC_STATE	PB_STATE	STATE		CC_STAT	
R-0b	R-0b	R-X	R-X	R-X		R-X	

Table 5-13. STATUS Register Field Descriptions

Bit	Field	Type	Reset	Description
7	FSEAL	R	0b	Freshness seal (FSEAL) status. Note: See Section 5.6.2 for details. 0b = FSEAL is in native state (fresh) 1b = FSEAL is broken
6	EE	R	0b	EEPROM status 0b = EEPROM values have not been changed from factory default setting 1b = EEPROM values have been changed from factory default settings
5	AC_STATE	R	X	AC_DET input status bit 0b = AC_DET input is inactive (AC_DET input pin is high) 1b = AC_DET input is active (AC_DET input is low)
4	PB_STATE	R	X	PB input status bit 0b = Push Button input is inactive (PB input pin is high) 1b = Push Button input is active (PB input pin is low)
3-2	STATE	R	X	State machine STATE indication 0h = PMIC is in transitional state 1h = PMIC is in WAIT_PWR_EN state 2h = PMIC is in ACTIVE state 3h = PMIC is in SUSPEND state
1-0	CC_STAT	R	X	Coin cell state of charge. Note: Coin-cell voltage acquisition must be triggered first before status bits are valid. See CC_AQ bit in Section 5.6.4.7 . 0h = $V_{CC} < V_{LOW_LEVEL}$; Coin cell is not present or approaching end-of-life (EOL) 1h = $V_{LOW_LEVEL} < V_{CC} < V_{GOOD_LEVEL}$; Coin cell voltage is LOW. 2h = $V_{GOOD_LEVEL} < V_{CC} < V_{IDEAL_LEVEL}$; Coin cell voltage is GOOD. 3h = $V_{IDEAL} < V_{CC}$; Coin cell voltage is IDEAL.

5.6.4.7 CONTROL Register (subaddress = 0x6) [reset = 0x0]

CONTROL is shown in [Figure 5-42](#) and described in [Table 5-14](#).

Return to [Summary Table](#).

Figure 5-42. CONTROL Register

7	6	5	4	3	2	1	0
RESERVED						OFFnPFO	CC_AQ
R-0h						R/W-0b	R/W-0b

Table 5-14. CONTROL Register Field Descriptions

Bit	Field	Type	Reset	Description
7-2	RESERVED	R	0h	
1	OFFnPFO	R/W	0h	Power-fail shutdown bit 0b = nPFO has no effect on PMIC state 1b = All rails are shut down and PMIC enters OFF state when PFI comparator trips (nPFO is low)
0	CC_AQ	R/W	0h	Coin Cell battery voltage acquisition start bit 0b = No significance 1b = Triggers voltage acquisition. Bit is automatically reset to 0.

5.6.4.8 FLAG Register (subaddress = 0x7) [reset = 0x0]

FLAG is shown in [Figure 5-43](#) and described in [Table 5-15](#).

Return to [Summary Table](#).

Figure 5-43. FLAG Register

7	6	5	4	3	2	1	0
GPO3_FLG	GPO2_FLG	GPO1_FLG	LDO1_FLG	DC4_FLG	DC3_FLG	DC2_FLG	DC1_FLG
R-0b	R-0b	R-0b	R-0b	R-0b	R-0b	R-0b	R-0b

Table 5-15. FLAG Register Field Descriptions

Bit	Field	Type	Reset	Description
7	GPO3_FLG	R	0b	GPO3 Flag bit 0b = Device powered up from OFF or SUSPEND state and GPO3 was disabled while in SUSPEND. 1b = Device powered up from SUSPEND state and GPO3 was enabled while in SUSPEND.
6	GPO2_FLG	R	0b	GPO2 Flag bit 0b = Device powered up from OFF or SUSPEND state and GPO2 was disabled while in SUSPEND. 1b = Device powered up from SUSPEND state and GPO2 was enabled while in SUSPEND.
5	GPO1_FLG	R	0b	GPO1 Flag bit 0b = Device powered up from OFF or SUSPEND state and GPO1 was disabled while in SUSPEND. 1b = Device powered up from SUSPEND state and GPO1 was enabled while in SUSPEND.
4	LDO1_FLG	R	0b	LDO1 Flag bit 0b = Device powered up from OFF or SUSPEND state and LDO1 was disabled while in SUSPEND. 1b = Device powered up from SUSPEND state and LDO1 was enabled while in SUSPEND.
3	DC4_FLG	R	0b	DCDC4 Flag bit 0b = Device powered up from OFF or SUSPEND state and DCDC4 was disabled while in SUSPEND. 1b = Device powered up from SUSPEND state and DCDC4 was enabled while in SUSPEND.
2	DC3_FLG	R	0b	DCDC3 Flag bit 0b = Device powered up from OFF or SUSPEND state and DCDC3 was disabled while in SUSPEND. 1b = Device powered up from SUSPEND state and DCDC3 was enabled while in SUSPEND.
1	DC2_FLG	R	0b	DCDC2 Flag bit 0b = Device powered up from OFF or SUSPEND state and DCDC2 was disabled while in SUSPEND. 1b = Device powered up from SUSPEND state and DCDC2 was enabled while in SUSPEND.

Table 5-15. FLAG Register Field Descriptions (continued)

Bit	Field	Type	Reset	Description
0	DC1_FLG	R	0b	DCDC1 Flag bit 0b = Device powered up from OFF or SUSPEND state and DCDC1 was disabled while in SUSPEND. 1b = Device powered up from SUSPEND state and GDCDC1PO3 was enabled while in SUSPEND.

5.6.4.9 PASSWORD Register (subaddress = 0x10) [reset = 0x0]

PASSWORD is shown in [Figure 5-44](#) and described in [Table 5-16](#).

Return to [Summary Table](#).

Figure 5-44. PASSWORD Register

7	6	5	4	3	2	1	0
PWRD							
R/W-0h							

Table 5-16. PASSWORD Register Field Descriptions

Bit	Field	Type	Reset	Description
7-0	PWRD	R/W	0h	Register is used for accessing password protected registers (see Section 5.6.1 for details). Breaking the freshness seal (see Section 5.6.2 for details). Programming power-up default values (see Section 5.5.1 for details). Read-back always yields 0x00.

5.6.4.10 ENABLE1 Register (subaddress = 0x11) [reset = 0x0]

ENABLE1 is shown in [Figure 5-45](#) and described in [Table 5-17](#).

Return to [Summary Table](#).

Password protected.

Figure 5-45. ENABLE1 Register

7	6	5	4	3	2	1	0
RESERVED		DC6_EN	DC5_EN	DC4_EN	DC3_EN	DC2_EN	DC1_EN
R-0h		R/W-0b	R/W-0b	R/W-0b	R/W-0b	R/W-0b	R/W-0b

Table 5-17. ENABLE1 Register Field Descriptions

Bit	Field	Type	Reset	Description
7-6	RESERVED	R	0h	
5	DC6_EN	R/W	0b	DCDC6 enable bit. DCDC6 can only be disabled if FSEAL = 0. See Section 5.6.2 for details. 0b = Disabled 1b = Enabled
4	DC5_EN	R/W	0b	DCDC5 enable bit. Note: At power-up/down this bit is automatically updated by the internal power sequencer. DCDC5 can only be disabled if FSEAL = 0. See Section 5.6.2 for details. 0b = Disabled 1b = Enabled
3	DC4_EN	R/W	0b	DCDC4 enable bit. Note: At power-up/down this bit is automatically updated by the internal power sequencer. 0b = Disabled 1b = Enabled
2	DC3_EN	R/W	0b	DCDC3 enable bit. Note: At power-up/down this bit is automatically updated by the internal power sequencer. 0b = Disabled 1b = Enabled
1	DC2_EN	R/W	0b	DCDC2 enable bit. Note: At power-up/down this bit is automatically updated by the internal power sequencer. 0b = Disabled 1b = Enabled
0	DC1_EN	R/W	0b	DCDC1 enable bit. Note: At power-up/down this bit is automatically updated by the internal power sequencer. 0b = Disabled 1b = Enabled

5.6.4.11 ENABLE2 Register (subaddress = 0x12) [reset = 0x0]

ENABLE2 is shown in [Figure 5-46](#) and described in [Table 5-18](#).

Return to [Summary Table](#).

Password protected.

Figure 5-46. ENABLE2 Register

7	6	5	4	3	2	1	0
RESERVED	GPIO3	GPIO2	GPIO1	LS3_EN	LS2_EN	LS1_EN	LDO1_EN
R-0b	R/W-0b	R/W-0b	R/W-0b	R/W-0b	R/W-0b	R/W-0b	R/W-0b

Table 5-18. ENABLE2 Register Field Descriptions

Bit	Field	Type	Reset	Description
7	RESERVED	R	0b	
6	GPIO3	R/W	0b	General purpose output 3 / reset polarity. Note: If DC12_RST bit (register 0x14) is set to 1 this bit has no function. 0b = GPIO3 output is driven low 1b = GPIO3 output is HiZ
5	GPIO2	R/W	0b	General purpose output 2. Note: If IO_SEL bit (register 0x13) is set to 1 this bit has no function. 0b = GPO2 output is driven low 1b = GPO2 output is HiZ
4	GPIO1	R/W	0b	General purpose output 1. Note: If IO_SEL bit (register 0x13) is set to 1 this bit has no function. 0b = GPO1 output is driven low 1b = GPO1 output is HiZ
3	LS3_EN	R/W	0b	Load switch 3 (LS3) enable bit 0b = Disabled 1b = Enabled
2	LS2_EN	R/W	0b	Load switch 2 (LS2) enable bit 0b = Disabled 1b = Enabled
1	LS1_EN	R/W	0b	Load switch 1 (LS1) enable bit. 0b = Disabled 1b = Enabled Note: At power-up/down this bit is automatically updated by the internal power sequencer.
0	LDO1_EN	R/W	0b	LDO1 enable bit. 0b = Disabled 1b = Enabled Note: At power-up/down this bit is automatically updated by the internal power sequencer.

5.6.4.12 CONFIG1 Register (subaddress = 0x13) [reset = 0x4C]

CONFIG1 is shown in [Figure 5-47](#) and described in [Table 5-19](#).

Return to [Summary Table](#).

Password protected.

Figure 5-47. CONFIG1 Register

7	6	5	4	3	2	1	0
TRST	GPO2_BUF	IO1_SEL	PGDLY		STRICT	UVLO	
R/W-0b	R/W-1b	R/W-0b	R/W-1h		R/W-1b	R/W-0h	

Table 5-19. CONFIG1 Register Field Descriptions

Bit	Field	Type	Reset	Description
7	TRST	R/W, E2	0b	Push-button reset time constant 0b = 8s 1b = 15s
6	GPO2_BUF	R/W, E2	1b	GPO2 output buffer configuration 0b = GPO2 buffer is configured as open-drain 1b = GPO2 buffer is configured as push-pull (high-level is driven to IN_LS1)
5	IO1_SEL	R/W, E2	0b	GPIO1 / GPO2 configuration bit. See Section 5.3.1.14 for details. 0b = GPIO1 is configured as general-purpose, open-drain output. GPO2 is independent output 1b = GPIO1 is configured as input, controlling GPO2. Intended for DDR3 reset signal control.
4-3	PGDLY	R/W, E2	1h	Power-Good delay. Note: Power-good delay applies to rising-edge only (power-up), not falling edge (power-down or fault) 0h = 10 ms 1h = 20 ms 2h = 50 ms 3h = 150 ms
2	STRICT	R/W, E2	1b	Supply Voltage Supervisor Sensitivity selection. See Section 4.5 for details. 0b = Power-good threshold (VOUT falling) has wider limits. Overvoltage is not monitored 1b = Power-good threshold (VOUT falling) has tight limits. Overvoltage is monitored.
1-0	UVLO	R/W, E2	0h	UVLO setting 0h = 2.75 V 1h = 2.95 V 2h = 3.25 V 3h = 3.35 V

5.6.4.13 CONFIG2 Register (subaddress = 0x14) [reset = 0xC0]

CONFIG2 is shown in [Figure 5-48](#) and described in [Table 5-20](#).

Return to [Summary Table](#).

Password protected.

Figure 5-48. CONFIG2 Register

7	6	5	4	3	2	1	0
DC12_RST	UVLOHYS	RESERVED		LS3ILIM		LS2ILIM	
R/W-1b	R/W-1b	R-0h		R/W-0h		R/W-0h	

Table 5-20. CONFIG2 Register Field Descriptions

Bit	Field	Type	Reset	Description
7	DC12_RST	R/W	1b, E2	DCDC1 and DCDC2 reset-pin enable 0b = GPIO3 is configured as general-purpose output 1b = GPIO3 is configured as warm-reset input to DCDC1 and DCDC2
6	UVLOHYS	R/W	1b, E2	UVLO hysteresis 0b = 200 mV 1b = 400 mV
5-4	RESERVED	R	0h	
3-2	LS3ILIM	R/W	0h	Load switch 3 (LS3) current limit selection 0h = 100 mA, (MIN = 98 mA) 1h = 200 mA, (MIN = 194 mA) 2h = 500 mA, (MIN = 475 mA) 3h = 1000 mA, (MIN = 900 mA) See the LS3 current limit specification in Section 4.5 for more details.
1-0	LS2ILIM	R/W	0h	Load switch 2 (LS2) current limit selection 0h = 100 mA, (MIN = 94 mA) 1h = 200 mA, (MIN = 188 mA) 2h = 500 mA, (MIN = 465 mA) 3h = 1000 mA, (MIN = 922 mA) See the LS2 current limit specification in Section 4.5 for more details.

5.6.4.14 CONFIG3 Register (subaddress = 0x15) [reset = 0x0]

CONFIG3 is shown in [Figure 5-49](#) and described in [Table 5-21](#).

Return to [Summary Table](#).

Password protected.

Figure 5-49. CONFIG3 Register

7	6	5	4	3	2	1	0
RESERVED		LS3nPFO	LS2nPFO	LS1nPFO	LS3DCHRG	LS2DCHRG	LS1DCHRG
R-0h		R/W-0b	R/W-0b	R/W-0b	R/W-0b	R/W-0b	R/W-0b

Table 5-21. CONFIG3 Register Field Descriptions

Bit	Field	Type	Reset	Description
7-6	RESERVED	R	0b	
5	LS3nPFO	R/W	0b	Load switch 3 power-fail disable bit 0b = Load switch status is not affected by power-fail comparator 1b = Load switch is disabled if power-fail comparator trips (nPFO is low)
4	LS2nPFO	R/W	0b	Load switch 2 power-fail disable bit 0b = Load switch status is not affected by power-fail comparator 1b = Load switch is disabled if power-fail comparator trips (nPFO is low)
3	LS1nPFO	R/W	0b	Load switch 1 power-fail disable bit 0b = Load switch status is not affected by power-fail comparator 1b = Load switch is disabled if power-fail comparator trips (nPFO is low)
2	LS3DCHRG	R/W	0b	Load switch 3 discharge enable bit 0b = Active discharge is disabled 1b = Active discharge is enabled (load switch output is actively discharged when switch is OFF)
1	LS2DCHRG	R/W	0b	Load switch 2 discharge enable bit 0b = Active discharge is disabled 1b = Active discharge is enabled (load switch output is actively discharged when switch is OFF)
0	LS1DCHRG	R/W	0b	Load switch 1 discharge enable bit 0b = Active discharge is disabled 1b = Active discharge is enabled (load switch output is actively discharged when switch is OFF)

5.6.4.15 DCDC1 Register (offset = 0x16) [reset = 0x99]

DCDC1 is shown in [Figure 5-50](#) and described in [Table 5-22](#).

Return to [Summary Table](#).

Note 1: This register is password protected. For more information, see [Section 5.6.1](#).

Note 2: A 5-ms blanking time of the overvoltage and undervoltage monitoring occurs when a write is performed on the DCDC1 register.

Note 3: To change the output voltage of DCDC1, the GO bit or the GODSBL bit must be set to 1b in register 0x1A.

Figure 5-50. DCDC1 Register

7	6	5	4	3	2	1	0
PFM	RESERVED						DCDC1
R/W-1b	R-0b						R/W-19h

Table 5-22. DCDC1 Register Field Descriptions

Bit	Field	Type	Reset	Description
7	PFM	R/W	1b	Pulse Frequency Modulation (PFM, also known as pulse-skip-mode) enable. PFM mode improves light-load efficiency. Actual PFM mode operation depends on load condition. 0b = Disabled (forced PWM) 1b = Enabled
6	RESERVED	R	0b	

Table 5-22. DCDC1 Register Field Descriptions (continued)

Bit	Field	Type	Reset	Description
5-0	DCDC1	R/W, E2	19h	DCDC1 output voltage setting 0h = 0.850 1h = 0.860 2h = 0.870 3h = 0.880 4h = 0.890 5h = 0.900 6h = 0.910 7h = 0.920 8h = 0.930 9h = 0.940 Ah = 0.950 Bh = 0.960 Ch = 0.970 Dh = 0.980 Eh = 0.990 Fh = 1.000 10h = 1.010 11h = 1.020 12h = 1.030 13h = 1.040 14h = 1.050 15h = 1.060 16h = 1.070 17h = 1.080 18h = 1.090 19h = 1.100 1Ah = 1.110 1Bh = 1.120 1Ch = 1.130 1Dh = 1.140 1Eh = 1.150 1Fh = 1.160 20h = 1.170 21h = 1.180 22h = 1.190 23h = 1.200

Table 5-22. DCDC1 Register Field Descriptions (continued)

Bit	Field	Type	Reset	Description
				24h = 1.210
				25h = 1.220
				26h = 1.230
				27h = 1.240
				28h = 1.250
				29h = 1.260
				2Ah = 1.270
				2Bh = 1.280
				2Ch = 1.290
				2Dh = 1.300
				2Eh = 1.310
				2Fh = 1.320
				30h = 1.330
				31h = 1.340
				32h = 1.350
				33h = 1.375
				34h = 1.400
				35h = 1.425
				36h = 1.450
				37h = 1.475
				38h = 1.500
				39h = 1.525
				3Ah = 1.550
				3Bh = 1.575
				3Ch = 1.600
				3Dh = 1.625
				3Eh = 1.650
				3Fh = 1.675

5.6.4.16 DCDC2 Register (subaddress = 0x17) [reset = 0x99]

DCDC2 is shown in [Figure 5-51](#) and described in [Table 5-23](#).

Return to [Summary Table](#).

Note 1: This register is password protected. For more information, see [Section 5.6.1](#).

Note 2: A 5-ms blanking time of the overvoltage and undervoltage monitoring occurs when a write is performed on the DCDC2 register.

Note 3: To change the output voltage of DCDC2, the GO bit or the GODSBL bit must be set to 1b in register 0x1A.

Figure 5-51. DCDC2 Register

7	6	5	4	3	2	1	0
PFM	RESERVED						DCDC2
R/W-1b	R-0b						R/W-19h

Table 5-23. DCDC2 Register Field Descriptions

Bit	Field	Type	Reset	Description
7	PFM	R/W	1b	Pulse frequency modulation (PFM, also known as pulse-skip-mode) enable. PFM mode improves light-load efficiency. Actual PFM mode operation depends on load condition. 0b = Disabled (forced PWM) 1b = Enabled
6	RESERVED	R	0b	

Table 5-23. DCDC2 Register Field Descriptions (continued)

Bit	Field	Type	Reset	Description
5-0	DCDC2	R/W, E2	19h	DCDC2 output voltage setting 0h = 0.850 1h = 0.860 2h = 0.870 3h = 0.880 4h = 0.890 5h = 0.900 6h = 0.910 7h = 0.920 8h = 0.930 9h = 0.940 Ah = 0.950 Bh = 0.960 Ch = 0.970 Dh = 0.980 Eh = 0.990 Fh = 1.000 10h = 1.010 11h = 1.020 12h = 1.030 13h = 1.040 14h = 1.050 15h = 1.060 16h = 1.070 17h = 1.080 18h = 1.090 19h = 1.100 1Ah = 1.110 1Bh = 1.120 1Ch = 1.130 1Dh = 1.140 1Eh = 1.150 1Fh = 1.160 20h = 1.170 21h = 1.180 22h = 1.190 23h = 1.200

Table 5-23. DCDC2 Register Field Descriptions (continued)

Bit	Field	Type	Reset	Description
				24h = 1.210
				25h = 1.220
				26h = 1.230
				27h = 1.240
				28h = 1.250
				29h = 1.260
				2Ah = 1.270
				2Bh = 1.280
				2Ch = 1.290
				2Dh = 1.300
				2Eh = 1.310
				2Fh = 1.320
				30h = 1.330
				31h = 1.340
				32h = 1.350
				33h = 1.375
				34h = 1.400
				35h = 1.425
				36h = 1.450
				37h = 1.475
				38h = 1.500
				39h = 1.525
				3Ah = 1.550
				3Bh = 1.575
				3Ch = 1.600
				3Dh = 1.625
				3Eh = 1.650
				3Fh = 1.675

5.6.4.17 DCDC3 Register (subaddress = 0x18) [reset = 0x8C]

DCDC3 is shown in [Figure 5-52](#) and described in [Table 5-24](#).

Return to [Summary Table](#).

Note 1: This register is password protected. For more information, see [Section 5.6.1](#).

Note 2: A 5-ms blanking time of the overvoltage and undervoltage monitoring occurs when a write is performed on the DCDC3 register.

NOTE

Power-up default may differ depending on RSEL value. See [Section 5.3.1.13](#) for details.

Figure 5-52. DCDC3 Register

7	6	5	4	3	2	1	0
PFM	RESERVED						DCDC3
R/W-1b	R-0b						R/W-Ch

Table 5-24. DCDC3 Register Field Descriptions

Bit	Field	Type	Reset	Description
7	PFM	R/W	1b	Pulse Frequency Modulation (PFM, also known as pulse-skip-mode) enable. PFM mode improves light-load efficiency. Actual PFM mode operation depends on load condition. 0b = Disabled (forced PWM) 1b = Enabled
6	RESERVED	R	0b	

Table 5-24. DCDC3 Register Field Descriptions (continued)

Bit	Field	Type	Reset	Description
5-0	DCDC3	R/W, E2	Ch	DCDC3 output voltage setting 0h = 0.900 1h = 0.925 2h = 0.950 3h = 0.975 4h = 1.000 5h = 1.025 6h = 1.050 7h = 1.075 8h = 1.100 9h = 1.125 Ah = 1.150 Bh = 1.175 Ch = 1.200 Dh = 1.225 Eh = 1.250 Fh = 1.275 10h = 1.300 11h = 1.325 12h = 1.350 13h = 1.375 14h = 1.400 15h = 1.425 16h = 1.450 17h = 1.475 18h = 1.500 19h = 1.525 1Ah = 1.550 1Bh = 1.600 1Ch = 1.650 1Dh = 1.700 1Eh = 1.750 1Fh = 1.800 20h = 1.850 21h = 1.900 22h = 1.950 23h = 2.000

Table 5-24. DCDC3 Register Field Descriptions (continued)

Bit	Field	Type	Reset	Description
				24h = 2.050
				25h = 2.100
				26h = 2.150
				27h = 2.200
				28h = 2.250
				29h = 2.300
				2Ah = 2.350
				2Bh = 2.400
				2Ch = 2.450
				2Dh = 2.500
				2Eh = 2.550
				2Fh = 2.600
				30h = 2.650
				31h = 2.700
				32h = 2.750
				33h = 2.800
				34h = 2.850
				35h = 2.900
				36h = 2.950
				37h = 3.000
				38h = 3.050
				39h = 3.100
				3Ah = 3.150
				3Bh = 3.200
				3Ch = 3.250
				3Dh = 3.300
				3Eh = 3.350
				3Fh = 3.400

5.6.4.18 DCDC4 Register (subaddress = 0x19) [reset = 0xB2]

DCDC4 is shown in [Figure 5-53](#) and described in [Table 5-25](#).

Return to [Summary Table](#).

Note 1: This register is password protected. For more information, see [Section 5.6.1](#).

Note 2: A 5-ms blanking time of the overvoltage and undervoltage monitoring occurs when a write is performed on the DCDC4 register.

NOTE

Power-up default may differ depending on RSEL value. See [Section 5.3.1.13](#) for details. The Reserved setting should not be selected and the output voltage settings should not be modified while the converter is operating.

Figure 5-53. DCDC4 Register

7	6	5	4	3	2	1	0
PFM	RESERVED						DCDC4
R/W-1b	R-0b						R/W-32h

Table 5-25. DCDC4 Register Field Descriptions

Bit	Field	Type	Reset	Description
7	PFM	R/W	1b	Pulse Frequency Modulation (PFM, also known as pulse-skip-mode) enable. PFM mode improves light-load efficiency. Actual PFM mode operation depends on load condition. 0b = Disabled (forced PWM) 1b = Enabled
6	RESERVED	R	0b	

Table 5-25. DCDC4 Register Field Descriptions (continued)

Bit	Field	Type	Reset	Description
5-0	DCDC4	R/W, E2	32h	DCDC4 output voltage setting 0h = 1.175 1h = 1.200 2h = 1.225 3h = 1.250 4h = 1.275 5h = 1.300 6h = 1.325 7h = 1.350 8h = 1.375 9h = 1.400 Ah = 1.425 Bh = 1.450 Ch = 1.475 Dh = 1.500 Eh = 1.525 Fh = 1.550 10h = 1.600 11h = 1.650 12h = 1.700 13h = 1.750 14h = 1.800 15h = 1.850 16h = 1.900 17h = 1.950 18h = 2.000 19h = 2.050 1Ah = 2.100 1Bh = 2.150 1Ch = 2.200 1Dh = 2.250 1Eh = 2.300 1Fh = 2.3500 20h = 2.400 21h = 2.450 22h = 2.500 23h = 2.550

Table 5-25. DCDC4 Register Field Descriptions (continued)

Bit	Field	Type	Reset	Description
				24h = 2.600
				25h = 2.650
				26h = 2.700
				27h = 2.750
				28h = 2.800
				29h = 2.850
				2Ah = 2.900
				2Bh = 2.950
				2Ch = 3.000
				2Dh = 3.050
				2Eh = 3.100
				2Fh = 3.150
				30h = 3.200
				31h = 3.250
				32h = 3.300
				33h = 3.350
				34h = 3.400
				35h = reserved
				36h = reserved
				37h = reserved
				38h = reserved
				39h = reserved
				3Ah = reserved
				3Bh = reserved
				3Ch = reserved
				3Dh = reserved
				3Eh = reserved
				3Fh = reserved

5.6.4.19 SLEW Register (subaddress = 0x1A) [reset = 0x6]

SLEW is shown in [Figure 5-54](#) and described in [Table 5-26](#).

Return to [Summary Table](#).

NOTE

Slew-rate control applies to DCDC1 and DCDC2 only. If changing from a higher voltage to lower voltage while STRICT = 1 and converters are in a no load state, PFM bit for DCDC1 and DCDC2 must be set to 0.

Figure 5-54. SLEW Register

7	6	5	4	3	2	1	0
GO	GODSBL	RESERVED			SLEW		
R/W-0b	R/W-0b	R-0h			R/W-6h		

Table 5-26. SLEW Register Field Descriptions

Bit	Field	Type	Reset	Description
7	GO	R/W	0b	Go bit. Note: Bit is automatically reset at the end of the voltage transition 0b = No change 1b = Initiates the transition from present state to the output voltage setting currently stored in DCDC1 / DCDC2 register. SLEW setting does apply.
6	GODSBL	R/W	0b	Go disable bit 0b = Enabled 1b = Disabled; DCDC1 and DCDC2 output voltage changes whenever set-point is updated in DCDC1 / DCDC2 register without having to write to the GO bit. SLEW setting does apply.
5-3	RESERVED	R	0h	
2-0	SLEW	R/W	6h	Output slew rate setting 0h = 160 μ s/step (0.0625 mV/ μ s at 10 mV per step) 1h = 80 μ s/step (0.125 mV/ μ s at 10 mV per step) 2h = 40 μ s/step (0.250 mV/ μ s at 10 mV per step) 3h = 20 μ s/step (0.500 mV/ μ s at 10 mV per step) 4h = 10 μ s/step (1.0 mV/ μ s at 10 mV per step) 5h = 5 μ s/step (2.0 mV/ μ s at 10 mV per step) 6h = 2.5 μ s/step (4.0 mV/ μ s at 10 mV per step) 7h = Immediate; Slew rate is only limited by control loop response time. Note: The actual slew rate depends on the voltage step per code. Refer to DCDCx registers for details.

5.6.4.20 LDO1 Register (subaddress = 0x1B) [reset = 0x1F]

LDO1 is shown in [Figure 5-55](#) and described in [Table 5-27](#).

Return to [Summary Table](#).

Note 1: This register is password protected. For more information, see [Section 5.6.1](#).

Note 2: A 5-ms blanking time of the overvoltage and undervoltage monitoring occurs when a write is performed on the LDO1 register.

Figure 5-55. LDO1 Register

7	6	5	4	3	2	1	0
RESERVED			LDO1				
R-0h			R/W-1Fh				

Table 5-27. LDO1 Register Field Descriptions

Bit	Field	Type	Reset	Description
7-6	RESERVED	R	0h	
5-0	LDO1	R/W, E2	1Fh	LDO1 output voltage setting 0h = 0.900 1h = 0.925 2h = 0.950 3h = 0.975 4h = 1.000 5h = 1.025 6h = 1.050 7h = 1.075 8h = 1.100 9h = 1.125 Ah = 1.150 Bh = 1.175 Ch = 1.200 Dh = 1.225 Eh = 1.250 Fh = 1.275 10h = 1.300 11h = 1.325 12h = 1.350 13h = 1.375 14h = 1.400 15h = 1.425 16h = 1.450 17h = 1.475 18h = 1.500 19h = 1.525

Table 5-27. LDO1 Register Field Descriptions (continued)

Bit	Field	Type	Reset	Description
				1Ah = 1.550
				1Bh = 1.600
				1Ch = 1.650
				1Dh = 1.700
				1Eh = 1.750
				1Fh = 1.800
				20h = 1.850
				21h = 1.900
				22h = 1.950
				23h = 2.000
				24h = 2.050
				25h = 2.100
				26h = 2.150
				27h = 2.200
				28h = 2.250
				29h = 2.300
				2Ah = 2.350
				2Bh = 2.400
				2Ch = 2.450
				2Dh = 2.500
				2Eh = 2.550
				2Fh = 2.600
				30h = 2.650
				31h = 2.700
				32h = 2.750
				33h = 2.800
				34h = 2.850
				35h = 2.900
				36h = 2.950
				37h = 3.000
				38h = 3.050
				39h = 3.100
				3Ah = 3.150
				3Bh = 3.200
				3Ch = 3.250
				3Dh = 3.300
				3Eh = 3.350
				3Fh = 3.400

5.6.4.21 SEQ1 Register (subaddress = 0x20) [reset = 0x0]

SEQ1 is shown in [Figure 5-56](#) and described in [Table 5-28](#).

Return to [Summary Table](#).

Password protected.

Figure 5-56. SEQ1 Register

7	6	5	4	3	2	1	0
DLY8	DLY7	DLY6	DLY5	DLY4	DLY3	DLY2	DLY1
R/W-0b	R/W-0b	R/W-0b	R/W-0b	R/W-0b	R/W-0b	R/W-0b	R/W-0b

Table 5-28. SEQ1 Register Field Descriptions

Bit	Field	Type	Reset	Description
7	DLY8	R/W, E2	0b	Delay8 (occurs after Strobe8 and before Strobe9) 0b = 2 ms 1b = 5 ms
6	DLY7	R/W, E2	0b	Delay7 (occurs after Strobe7 and before Strobe8) 0b = 2 ms 1b = 5 ms
5	DLY6	R/W, E2	0b	Delay6 (occurs after Strobe6 and before Strobe7) 0b = 2 ms 1b = 5 ms
4	DLY5	R/W, E2	0b	Delay5 (occurs after Strobe5 and before Strobe6) 0b = 2 ms 1b = 5 ms
3	DLY4	R/W, E2	0b	Delay4 (occurs after Strobe4 and before Strobe5) 0b = 2 ms 1b = 5 ms
2	DLY3	R/W, E2	0b	Delay3 (occurs after Strobe3 and before Strobe4) 0b = 2 ms 1b = 5 ms
1	DLY2	R/W, E2	0b	Delay2 (occurs after Strobe2 and before Strobe3) 0b = 2 ms 1b = 5 ms
0	DLY1	R/W, E2	0b	Delay1 (occurs after Strobe1 and before Strobe2) 0b = 2 ms 1b = 5 ms

5.6.4.22 SEQ2 Register (subaddress = 0x21) [reset = 0x0]

SEQ2 is shown in [Figure 5-57](#) and described in [Table 5-29](#).

Return to [Summary Table](#).

Password protected.

Figure 5-57. SEQ2 Register

7	6	5	4	3	2	1	0
DLYFCTR	RESERVED					DLY9	
R/W -0b	R-0h					R/W -0b	

Table 5-29. SEQ2 Register Field Descriptions

Bit	Field	Type	Reset	Description
7	DLYFCTR	R/W, E2	0b	Power-down delay factor 0b = 1x 1b = 10x (delay times are multiplied by 10x during power-down) Note: DLYFCTR has no effect on power-up timing.
6-1	RESERVED	R	0h	
0	DLY9	R/W, E2	0b	Delay9 (occurs after Strobe9 and before Strobe10) 0b = 2 ms 1b = 5 ms

5.6.4.23 SEQ3 Register (subaddress = 0x22) [reset = 0x98]

SEQ3 is shown in [Figure 5-58](#) and described in [Table 5-30](#).

Return to [Summary Table](#).

Password protected.

Figure 5-58. SEQ3 Register

7	6	5	4	3	2	1	0
DC2_SEQ				DC1_SEQ			
R/W-9h				R/W-8h			

Table 5-30. SEQ3 Register Field Descriptions

Bit	Field	Type	Reset	Description
7-4	DC2_SEQ	R/W, E2	9h	DCDC2 enable STROBE 0h = Rail is not controlled by sequencer 1h = Rail is not controlled by sequencer 2h = Rail is not controlled by sequencer 3h = Enable at STROBE3 4h = Enable at STROBE4 5h = Enable at STROBE5 6h = Enable at STROBE6 7h = Enable at STROBE7 8h = Enable at STROBE8 9h = Enable at STROBE9 Ah = Enable at STROBE10 Bh = Rail is not controlled by sequencer Ch = Rail is not controlled by sequencer Dh = Rail is not controlled by sequencer Eh = Rail is not controlled by sequencer Fh = Rail is not controlled by sequencer

Table 5-30. SEQ3 Register Field Descriptions (continued)

Bit	Field	Type	Reset	Description
3-0	DC1_SEQ	R/W, E2	8h	DCDC1 enable STROBE 0h = Rail is not controlled by sequencer 1h = Rail is not controlled by sequencer 2h = Rail is not controlled by sequencer 3h = Enable at STROBE3 4h = Enable at STROBE4 5h = Enable at STROBE5 6h = Enable at STROBE6 7h = Enable at STROBE7 8h = Enable at STROBE8 9h = Enable at STROBE9 Ah = Enable at STROBE10 Bh = Rail is not controlled by sequencer Ch = Rail is not controlled by sequencer Dh = Rail is not controlled by sequencer Eh = Rail is not controlled by sequencer Fh = Rail is not controlled by sequencer

5.6.4.24 SEQ4 Register (subaddress = 0x23) [reset = 0x75]

SEQ4 is shown in [Figure 5-59](#) and described in [Table 5-31](#).

Return to [Summary Table](#).

Password protected.

Figure 5-59. SEQ4 Register

7	6	5	4	3	2	1	0
DC4_SEQ				DC3_SEQ			
R/W-7h				R/W-5h			

Table 5-31. SEQ4 Register Field Descriptions

Bit	Field	Type	Reset	Description
7-4	DC4_SEQ	R/W, E2	7h	DCDC4 enable STROBE 0h = Rail is not controlled by sequencer 1h = Rail is not controlled by sequencer 2h = Rail is not controlled by sequencer 3h = Enable at STROBE3 4h = Enable at STROBE4 5h = Enable at STROBE5 6h = Enable at STROBE6 7h = Enable at STROBE7 8h = Enable at STROBE8 9h = Enable at STROBE9 Ah = Enable at STROBE10 Bh = Rail is not controlled by sequencer Ch = Rail is not controlled by sequencer Dh = Rail is not controlled by sequencer Eh = Rail is not controlled by sequencer Fh = Rail is not controlled by sequencer

Table 5-31. SEQ4 Register Field Descriptions (continued)

Bit	Field	Type	Reset	Description
3-0	DC3_SEQ	R/W, E2	5h	DCDC3 enable STROBE 0h = Rail is not controlled by sequencer 1h = Rail is not controlled by sequencer 2h = Rail is not controlled by sequencer 3h = Enable at STROBE3 4h = Enable at STROBE4 5h = Enable at STROBE5 6h = Enable at STROBE6 7h = Enable at STROBE7 8h = Enable at STROBE8 9h = Enable at STROBE9 Ah = Enable at STROBE10 Bh = Rail is not controlled by sequencer Ch = Rail is not controlled by sequencer Dh = Rail is not controlled by sequencer Eh = Rail is not controlled by sequencer Fh = Rail is not controlled by sequencer

5.6.4.25 SEQ5 Register (subaddress = 0x24) [reset = 0x12]

SEQ5 is shown in [Figure 5-60](#) and described in [Table 5-32](#).

Return to [Summary Table](#).

Password protected.

Figure 5-60. SEQ5 Register

7	6	5	4	3	2	1	0
RESERVED		DC6_SEQ		RESERVED		DC5_SEQ	
R-0h		R/W-1h		R-0h		R/W-2h	

Table 5-32. SEQ5 Register Field Descriptions

Bit	Field	Type	Reset	Description
7-6	RESERVED	R	0h	
5-4	DC6_SEQ	R/W, E2	1h	DCDC6 enable STROBE. Note: Strobe 1 and 2 are executed only if FSEAL = 0. DCDC5 and 6 cannot be disabled by sequencer once freshness seal is broken. 0h = Rail is not controlled by sequencer 1h = Enable at STROBE1 2h = Enable at STROBE2 3h = Rail is not controlled by sequencer
3-2	RESERVED	R	0h	
1-0	DC5_SEQ	R/W, E2	2h	DCDC5 enable STROBE. Note: Strobe 1 and 2 are executed only if FSEAL = 0. DCDC5 and 6 cannot be disabled by sequencer once freshness seal is broken. 0h = Rail is not controlled by sequencer 1h = Enable at STROBE1 2h = Enable at STROBE2 3h = Rail is not controlled by sequencer

5.6.4.26 SEQ6 Register (subaddress = 0x25) [reset = 0x63]

SEQ6 is shown in [Figure 5-61](#) and described in [Table 5-33](#).

Return to [Summary Table](#).

Password protected.

Figure 5-61. SEQ6 Register

7	6	5	4	3	2	1	0
LS1_SEQ				LDO1_SEQ			
R/W-6h				R/W-3h			

Table 5-33. SEQ6 Register Field Descriptions

Bit	Field	Type	Reset	Description
7-4	LS1_SEQ	R/W, E2	6h	LS1 enable STROBE 0h = Rail is not controlled by sequencer 1h = Rail is not controlled by sequencer 2h = Rail is not controlled by sequencer 3h = Enable at STROBE3 4h = Enable at STROBE4 5h = Enable at STROBE5 6h = Enable at STROBE6 7h = Enable at STROBE7 8h = Enable at STROBE8 9h = Enable at STROBE9 Ah = Enable at STROBE10 Bh = Rail is not controlled by sequencer Ch = Rail is not controlled by sequencer Dh = Rail is not controlled by sequencer Eh = Rail is not controlled by sequencer Fh = Rail is not controlled by sequencer

Table 5-33. SEQ6 Register Field Descriptions (continued)

Bit	Field	Type	Reset	Description
3-0	LDO1_SEQ	R/W, E2	3h	LDO1 enable STROBE 0h = Rail is not controlled by sequencer 1h = Rail is not controlled by sequencer 2h = Rail is not controlled by sequencer 3h = Enable at STROBE3 4h = Enable at STROBE4 5h = Enable at STROBE5 6h = Enable at STROBE6 7h = Enable at STROBE7 8h = Enable at STROBE8 9h = Enable at STROBE9 Ah = Enable at STROBE10 Bh = Rail is not controlled by sequencer Ch = Rail is not controlled by sequencer Dh = Rail is not controlled by sequencer Eh = Rail is not controlled by sequencer Fh = Rail is not controlled by sequencer

5.6.4.27 SEQ7 Register (subaddress = 0x26) [reset = 0x3]

SEQ7 is shown in [Figure 5-62](#) and described in [Table 5-34](#).

Return to [Summary Table](#).

Password protected.

Figure 5-62. SEQ7 Register

7	6	5	4	3	2	1	0
GPO3_SEQ				GPO1_SEQ			
R/W-0h				R/W-3h			

Table 5-34. SEQ7 Register Field Descriptions

Bit	Field	Type	Reset	Description
7-4	GPO3_SEQ	R/W, E2	0h	GPO3 enable STROBE 0h = Rail is not controlled by sequencer 1h = Rail is not controlled by sequencer 2h = Rail is not controlled by sequencer 3h = Enable at STROBE3 4h = Enable at STROBE4 5h = Enable at STROBE5 6h = Enable at STROBE6 7h = Enable at STROBE7 8h = Enable at STROBE8 9h = Enable at STROBE9 Ah = Enable at STROBE10 Bh = Rail is not controlled by sequencer Ch = Rail is not controlled by sequencer Dh = Rail is not controlled by sequencer Eh = Rail is not controlled by sequencer Fh = Rail is not controlled by sequencer

Table 5-34. SEQ7 Register Field Descriptions (continued)

Bit	Field	Type	Reset	Description
3-0	GPO1_SEQ	R/W, E2	3h	GPO1 enable STROBE 0h = Rail is not controlled by sequencer 1h = Rail is not controlled by sequencer 2h = Rail is not controlled by sequencer 3h = Enable at STROBE3 4h = Enable at STROBE4 5h = Enable at STROBE5 6h = Enable at STROBE6 7h = Enable at STROBE7 8h = Enable at STROBE8 9h = Enable at STROBE9 Ah = Enable at STROBE10 Bh = Rail is not controlled by sequencer Ch = Rail is not controlled by sequencer Dh = Rail is not controlled by sequencer Eh = Rail is not controlled by sequencer Fh = Rail is not controlled by sequencer

6 Application and Implementation

NOTE

Information in the following applications sections is not part of the TI component specification, and TI does not warrant its accuracy or completeness. TI's customers are responsible for determining suitability of components for their purposes. Customers should validate and test their design implementation to confirm system functionality.

6.1 Application Information

The TPS65218D0 is designed to pair with various application processors. For detailed information on using TPS65218D0 with Sitara™ AM335x or Sitara AM437x processors, refer to [Powering the AM335x/AM437x with TPS65218](#). The typical application in [Section 6.2](#) is based on and uses terminology consistent with the Sitara™ family of processors.

6.1.1 Applications Without Backup Battery

In applications that require always-on supplies but no battery backup, the CC input to the power path must be connected to ground.

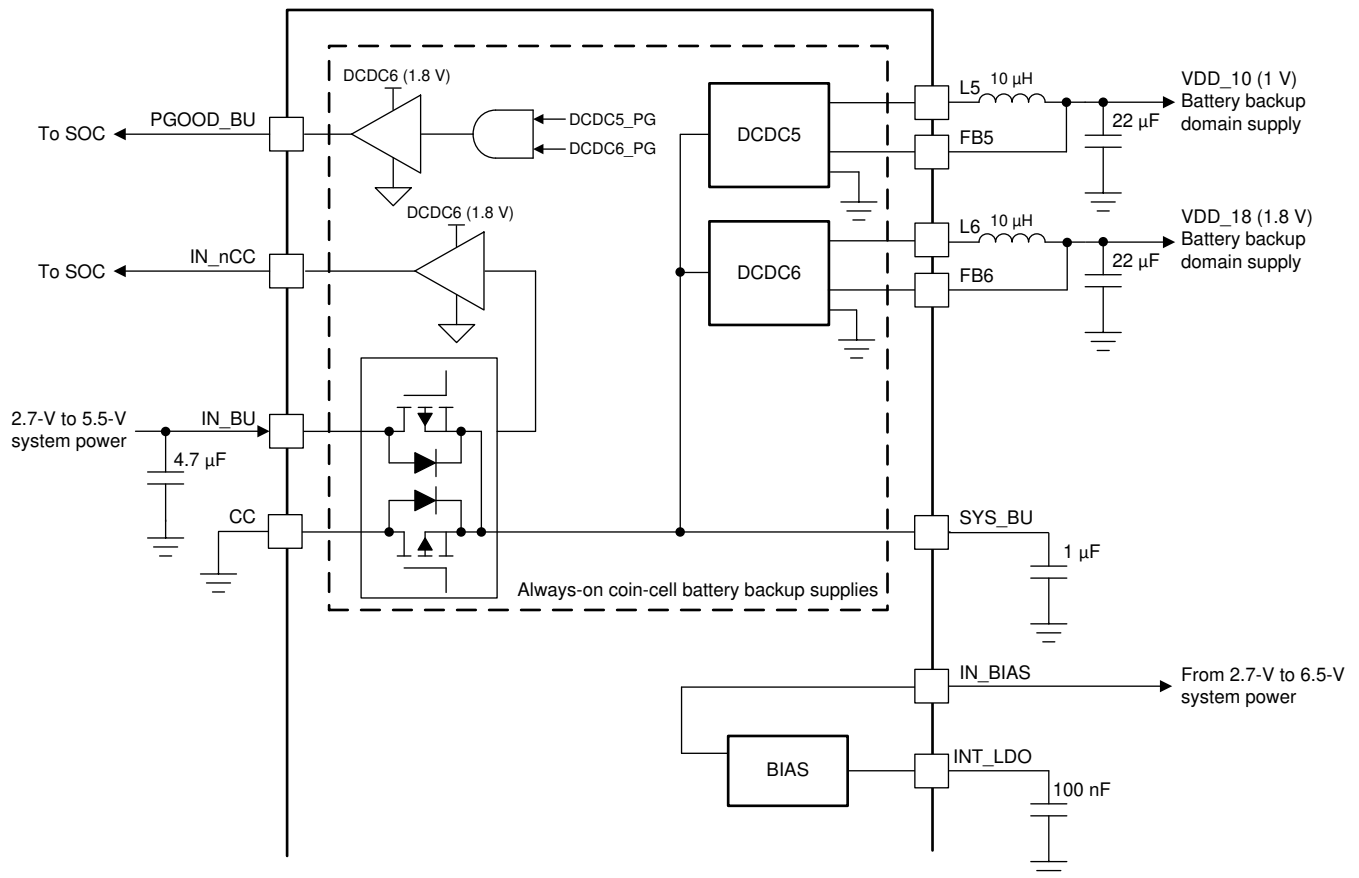

Figure 6-1. CC Input to Power Path

NOTE

In applications without backup battery, CC input must be tied to ground.

6.1.2 Applications Without Battery Backup Supplies

In applications that do not require always-on supplies, both inputs and the output of the power-path can simply be grounded. All pins related to DCDC5 and DCDC6 are also tied to ground, and PGOOD_BU and IN_nCC are kept floating. With the backup supplies completely disabled, the FSEAL bit in the STATUS register is undefined and should be ignored.

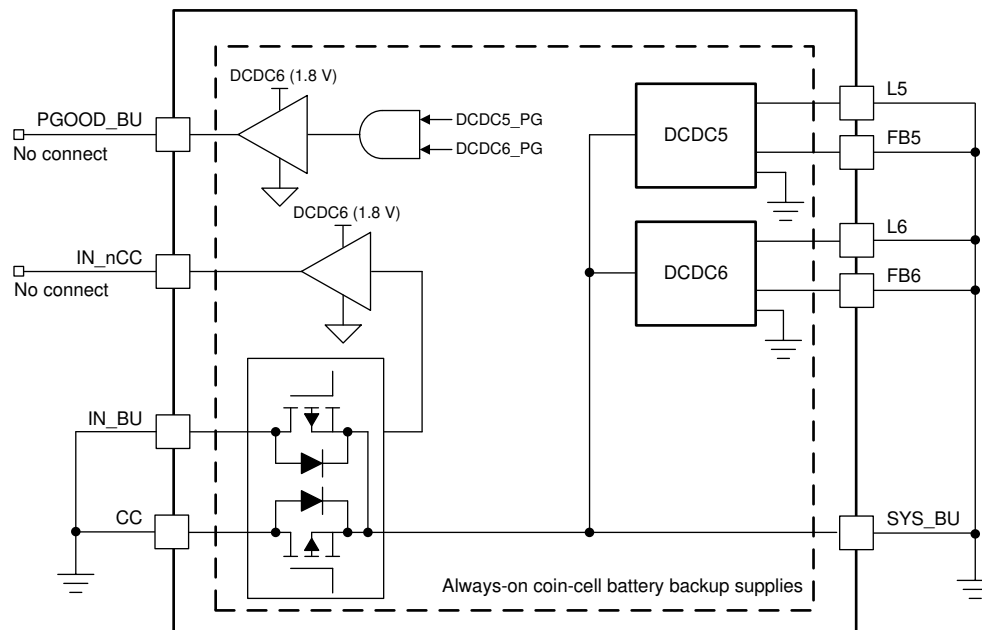
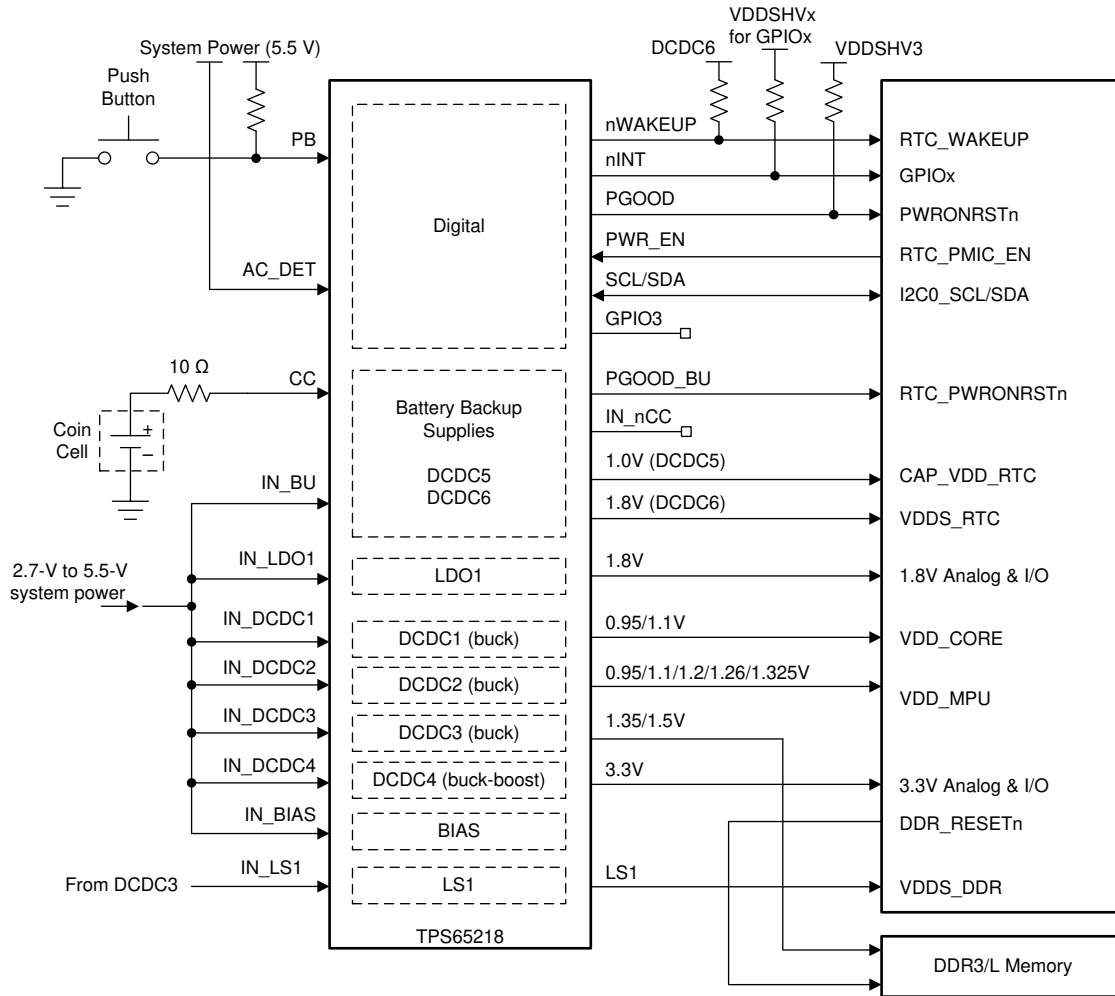

Figure 6-2. DCDC5 and DCDC6 Pins

NOTE

In applications that do not require always-on supplies, PGOOD_BU and IN_nCC can be kept floating. All other pins are tied to ground.

6.2 Typical Application



Copyright © 2017, Texas Instruments Incorporated

Figure 6-3. Typical Application Schematic

6.2.1 Design Requirements

Table 6-1 lists the design requirements.

Table 6-1. Design Parameters

	VOLTAGE	SEQUENCE
DCDC1	1.1 V	8
DCDC2	1.1 V	9
DCDC3	1.2 V	5
DCDC4	3.3 V	7
DCDC5	1.0 V	2
DCDC6	1.8 V	1
LDO1	1.8 V	3

6.2.2 Detailed Design Procedure

6.2.2.1 Output Filter Design

The step down converters (DCDC1, DCDC2, and DCDC3) on TPS65218D0 are designed to operate with effective inductance values in the range of 1 to 2.2 μH and with effective output capacitance in the range of 10 to 100 μF . The internal compensation is optimized to operate with an output filter of $L = 1.5 \mu\text{H}$ and $C_{\text{OUT}} = 10 \mu\text{F}$.

The buck boost converter (DCDC4) on TPS65218D0 is designed to operate with effective inductance values in the range of 1.2 to 2.2 μH . The internal compensation is optimized to operate with an output filter of $L = 1.5 \mu\text{H}$ and $C_{\text{OUT}} = 47 \mu\text{F}$.

The two battery backup converters (DCDC5 and DCDC6) are designed to operate with effective inductance values in the range of 4.7 to 22 μH . The internal compensation is optimized with an output filter of $L = 10 \mu\text{H}$ and $C_{\text{OUT}} = 20 \mu\text{F}$.

Larger or smaller inductor/capacitance values can be used to optimize performance of the device for specific operation conditions.

6.2.2.2 Inductor Selection for Buck Converters

The inductor value affects its peak to peak ripple current, the PWM to PFM transition point, the output voltage ripple, and the efficiency. The selected inductor must be rated for its DC resistance and saturation current. The inductor ripple current (ΔI_L) decreases with higher inductance and increases with higher V_{IN} or V_{OUT} . Equation 1 calculates the maximum inductor current ripple under static load conditions. The saturation current of the inductor should be rated higher than the maximum inductor current as calculated with Equation 2. This is recommended as during heavy load transient the inductor current will rise above the calculated value.

$$\Delta I_L = V_{\text{OUT}} \times \frac{1 - \frac{V_{\text{OUT}}}{V_{\text{IN}}}}{L \times f} \quad (1)$$

$$I_{L\text{max}} = I_{\text{OUTmax}} + \frac{\Delta I_L}{2}$$

where

- F = Switching frequency
- L = Inductor value
- ΔI_L = Peak-to-peak inductor ripple current
- $I_{L\text{max}}$ = Maximum inductor current

(2)

The following inductors have been used with the TPS65218D0 (see [Table 6-2](#)).

Table 6-2. List of Recommended Inductors

PART NUMBER	VALUE	SIZE (mm) [L x W x H]	MANUFACTURER
INDUCTORS FOR DCDC1, DCDC2, DCDC3, DCDC4			
SPM3012T-1R5M	1.5 μ H, 2.8 A, 77 m Ω	3.2 x 3.0 x 1.2	TDK
IHLP1212BZER1R5M11	1.5 μ H, 4.0 A, 28.5 m Ω	3.6 x 3.0 x 2.0	Vishay
INDUCTORS FOR DCDC5, DCDC6			
MLZ2012N100L	10 μ H, 110 mA, 300 m Ω	2012 / 0805 (2.00 x 1.25 x 1.25)	TDK
LQM21FN100M80	10 μ H, 100 mA, 300 m Ω	2012 / 0805 (2.00 x 1.25 x 1.25)	Murata

6.2.2.3 Output Capacitor Selection

The hysteretic PWM control scheme of the TPS65218D0 switching converters allows the use of tiny ceramic capacitors. Ceramic capacitors with low ESR values have the lowest output voltage ripple and are recommended. The output capacitor requires either an X7R or X5R dielectric.

At light load currents the converter operates in power save mode, and the output voltage ripple is dependent on the output capacitor value and the PFM peak inductor current. Higher output capacitor values minimize the voltage ripple in PFM Mode and tighten DC output accuracy in PFM mode.

The two battery backup converters (DCDC5 and DCDC6) always operate in PFM mode. For these converters, a capacitor of at least 20 μ F is recommended on the output to help minimize voltage ripple.

The buck-boost converter requires additional output capacitance to help maintain converter stability during high load conditions. At least 40 μ F of output capacitance is recommended and an additional 100-nF capacitor can be added to further filter output ripple at higher frequencies.

[Table 6-2](#) lists the recommended capacitors.

Table 6-3. List of Recommended Capacitors

PART NUMBER	VALUE	SIZE (mm) [L x W x H]	MANUFACTURER
CAPACITORS FOR VOLTAGES UP TO 5.5 V⁽¹⁾			
GRM188R60J105K	1 μ F	1608 / 0603 (1.6 x 0.8 x 0.8)	Murata
GRM21BR60J475K	4.7 μ F	2012 / 0805 (2.0 x 1.25 x 1.25)	Murata
GRM31MR60J106K	10 μ F	3216 / 1206 (3.2 x 1.6 x 1.6)	Murata
GRM31CR60J226K	22 μ F	3216 / 1206 (3.2 x 1.6 x 1.6)	Murata
CAPACITORS FOR VOLTAGES UP TO 3.3 V⁽¹⁾			
GRM21BR60J106K	10 μ F	2012 / 0805 (2.0 x 1.25 x 1.25)	Murata
GRM31CR60J476M	47 μ F	3216 / 1206 (3.2 x 1.6 x 1.6)	Murata

(1) The DC bias effect of ceramic capacitors must be considered when selecting a capacitor.

6.2.3 Application Curves

at $T_J = 25^\circ\text{C}$ unless otherwise noted

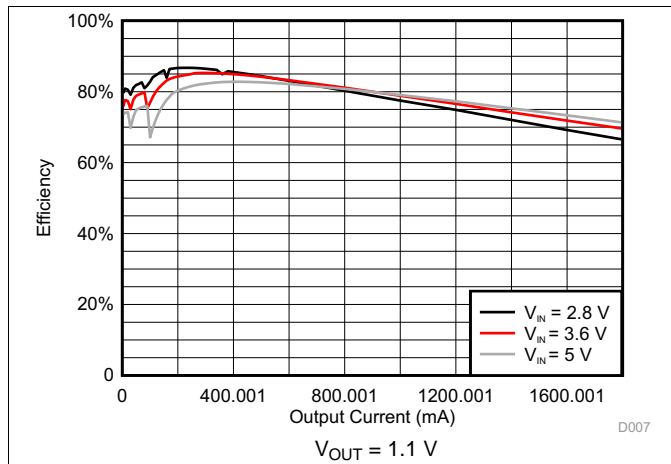

Figure 6-4. DCDC1/DCDC2 Efficiency

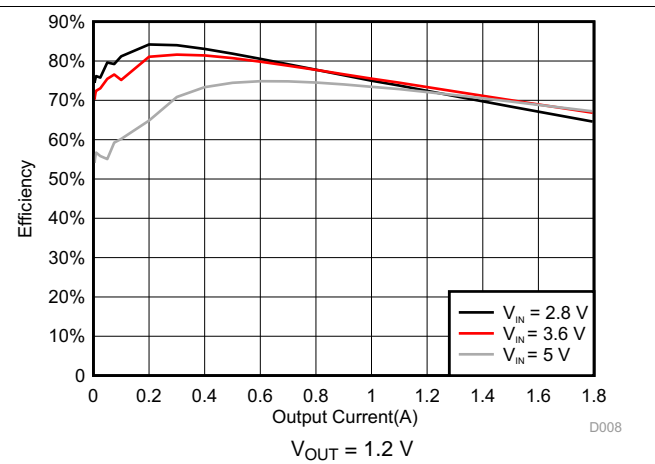

Figure 6-5. DCDC3 Efficiency

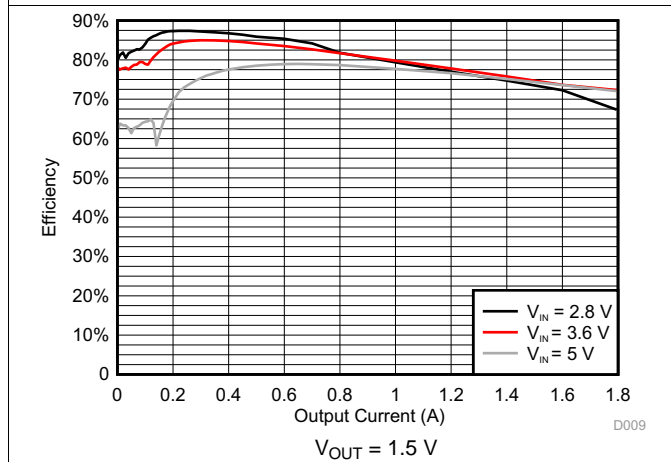

Figure 6-6. DCDC3 Efficiency

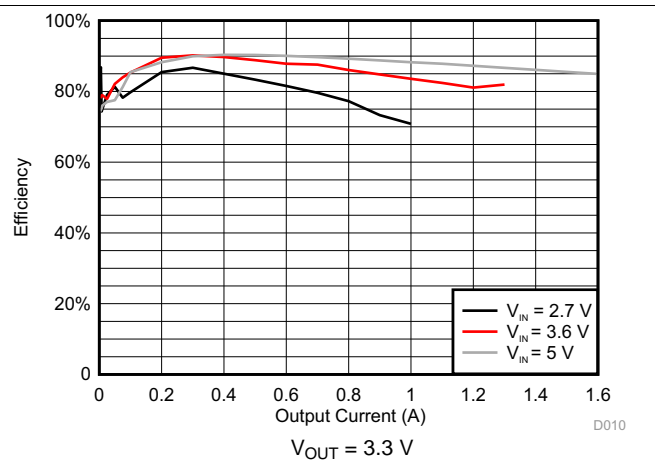

Figure 6-7. DCDC4 Efficiency

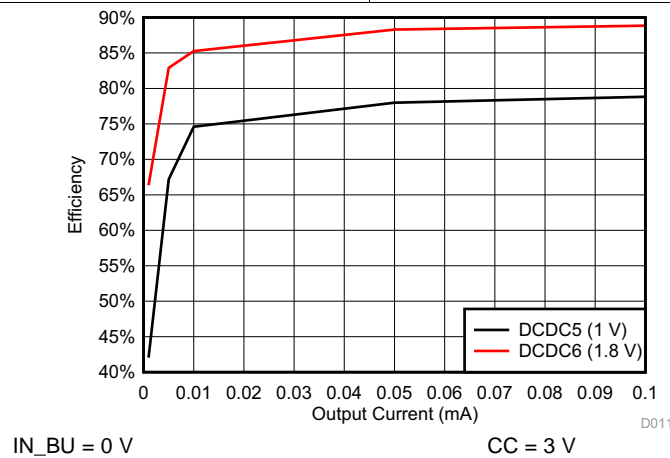

Figure 6-8. DCDC5/DCDC6 Efficiency

7 Power Supply Recommendations

The device is designed to operate with an input voltage supply range between 2.7 and 5.5 V. This input supply can be from a single cell Li-Ion battery or other externally regulated supply. If the input supply is located more than a few inches from the TPS65218D0 additional bulk capacitance may be required in addition to the ceramic bypass capacitors. An electrolytic capacitor with a value of 47 μF is a typical choice.

The coin cell back up input is designed to operate with an input voltage supply between 2.2 and 3.3 V. This input should be supplied by a coin cell battery with 3-V nominal voltage.

8 Layout

8.1 Layout Guidelines

Follow these layout guidelines:

- The IN_X pins should be bypassed to ground with a low ESR ceramic bypass capacitor. The typical recommended bypass capacitance is 4.7- μF with a X5R or X7R dielectric.
- The optimum placement is closest to the IN_X pins of the device. Take care to minimize the loop area formed by the bypass capacitor connection, the IN_X pin, and the thermal pad of the device.
- The thermal pad should be tied to the PCB ground plane with a minimum of 25 vias. See [Figure 8-2](#) for an example.
- The LX trace should be kept on the PCB top layer and free of any vias.
- The FBX traces should be routed away from any potential noise source to avoid coupling.
- DCDC4 Output capacitance should be placed immediately at the DCDC4 pin. Excessive distance between the capacitance and DCDC4 pin may cause poor converter performance.

8.2 Layout Example

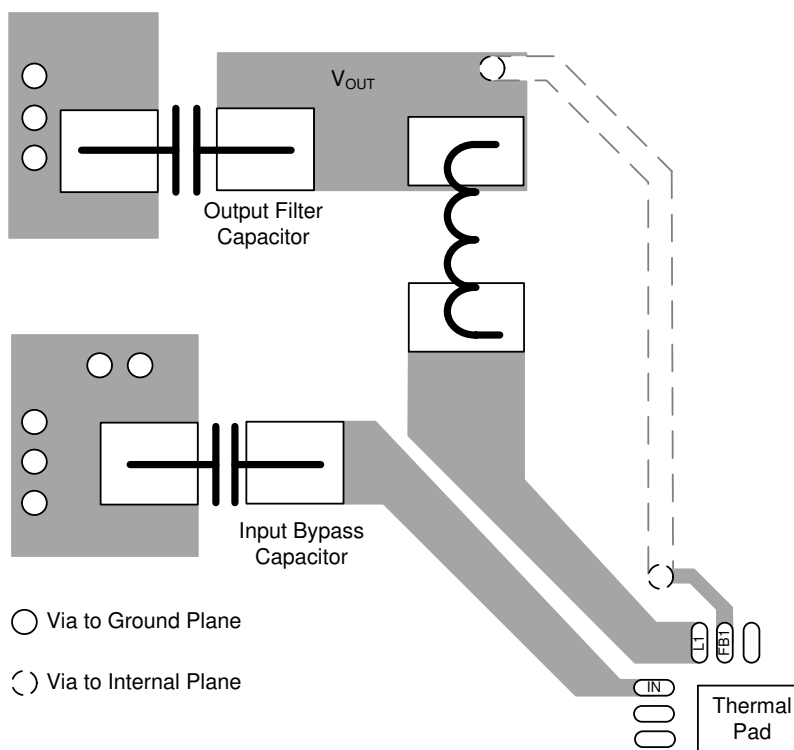
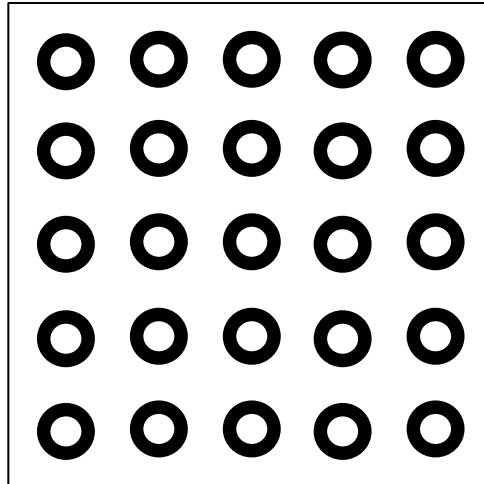

Figure 8-1. Layout Recommendation



Recommended Thermal Pad via size
Hole size (s) = 8 mil
Diameter (d) = 16 mil

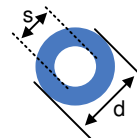

Figure 8-2. Thermal Pad Layout Recommendation

9 デバイスおよびドキュメントのサポート

9.1 デバイス・サポート

9.1.1 *Third-Party Products Disclaimer*

TI'S PUBLICATION OF INFORMATION REGARDING THIRD-PARTY PRODUCTS OR SERVICES DOES NOT CONSTITUTE AN ENDORSEMENT REGARDING THE SUITABILITY OF SUCH PRODUCTS OR SERVICES OR A WARRANTY, REPRESENTATION OR ENDORSEMENT OF SUCH PRODUCTS OR SERVICES, EITHER ALONE OR IN COMBINATION WITH ANY TI PRODUCT OR SERVICE.

9.2 ドキュメントのサポート

9.2.1 関連資料

関連資料については、以下を参照してください。

- テキサス・インスツルメンツ、『[降圧コンバータの電力段の基礎的計算](#)』アプリケーション・レポート
- テキサス・インスツルメンツ、『[昇降圧コンバータの設計計算](#)』アプリケーション・レポート
- テキサス・インスツルメンツ、『[プロセッサ・アプリケーション向けパワー・マネージメントIC \(PMIC\)による設計の強化](#)』アプリケーション・レポート
- テキサス・インスツルメンツ、『[TPS65218によるAM335x/AM437xへの電力供給](#)』ユーザー・ガイド
- テキサス・インスツルメンツ、『[TPS65218EVM](#)』ユーザー・ガイド
- テキサス・インスツルメンツ、『[TPS65218 産業アプリケーション向けパワー・マネージメントIC \(PMIC\)](#)』アプリケーション・レポート

9.3 ドキュメントの更新通知を受け取る方法

ドキュメントの更新についての通知を受け取るには、[ti.com](#)のデバイス製品フォルダを開いてください。右上の「アラートを受け取る」をクリックして登録すると、変更されたすべての製品情報に関するダイジェストを毎週受け取れます。変更の詳細については、修正されたドキュメントに含まれている改訂履歴をご覧ください。

9.4 Community Resources

The following links connect to TI community resources. Linked contents are provided "AS IS" by the respective contributors. They do not constitute TI specifications and do not necessarily reflect TI's views; see TI's [Terms of Use](#).

TI E2E™ Online Community The TI engineer-to-engineer (E2E) community was created to foster collaboration among engineers. At [e2e.ti.com](#), you can ask questions, share knowledge, explore ideas and help solve problems with fellow engineers.

Design Support *TI's Design Support* Quickly find helpful E2E forums along with design support tools and contact information for technical support.

9.5 商標

PowerPAD, Sitara, E2E are trademarks of Texas Instruments.
Cortex is a trademark of ARM Ltd.
ARM is a registered trademark of ARM Ltd.

9.6 静電気放電に関する注意事項



すべての集積回路は、適切なESD保護方法を用いて、取扱いと保存を行うようにして下さい。

静電気放電はわずかな性能の低下から完全なデバイスの故障に至るまで、様々な損傷を与えます。高精度の集積回路は、損傷に対して敏感であり、極めてわずかなパラメータの変化により、デバイスに規定された仕様に適合しなくなる場合があります。

9.7 Glossary

TI Glossary This glossary lists and explains terms, acronyms, and definitions.

10 メカニカル、パッケージ、および注文情報

以降のページには、メカニカル、パッケージ、および注文に関する情報が記載されています。これらの情報は、指定のデバイスに対して提供されている最新のデータです。このデータは予告なく変更されることがあり、ドキュメントが改訂される場合もあります。本データシートのブラウザ版を使用されている場合は、画面左側の説明をご覧ください。

PACKAGING INFORMATION

Orderable part number	Status (1)	Material type (2)	Package Pins	Package qty Carrier	RoHS (3)	Lead finish/ Ball material (4)	MSL rating/ Peak reflow (5)	Op temp (°C)	Part marking (6)
TPS65218D0PHPR	Active	Production	HTQFP (PHP) 48	1000 LARGE T&R	Yes	NIPDAU	Level-3-260C-168 HR	-40 to 105	T65218D0
TPS65218D0PHPR.A	Active	Production	HTQFP (PHP) 48	1000 LARGE T&R	Yes	NIPDAU	Level-3-260C-168 HR	-40 to 105	T65218D0
TPS65218D0PHPT	Active	Production	HTQFP (PHP) 48	250 SMALL T&R	Yes	NIPDAU	Level-3-260C-168 HR	-40 to 105	T65218D0
TPS65218D0PHPT.A	Active	Production	HTQFP (PHP) 48	250 SMALL T&R	Yes	NIPDAU	Level-3-260C-168 HR	-40 to 105	T65218D0
TPS65218D0PHPTG4	Active	Production	HTQFP (PHP) 48	250 SMALL T&R	Yes	NIPDAU	Level-3-260C-168 HR	-40 to 105	T65218D0
TPS65218D0PHPTG4.A	Active	Production	HTQFP (PHP) 48	250 SMALL T&R	Yes	NIPDAU	Level-3-260C-168 HR	-40 to 105	T65218D0
TPS65218D0RSLR	Active	Production	VQFN (RSL) 48	2500 LARGE T&R	Yes	NIPDAU	Level-3-260C-168 HR	-40 to 105	T65218D0
TPS65218D0RSLR.A	Active	Production	VQFN (RSL) 48	2500 LARGE T&R	Yes	NIPDAU	Level-3-260C-168 HR	-40 to 105	T65218D0
TPS65218D0RSLT	Active	Production	VQFN (RSL) 48	250 SMALL T&R	Yes	NIPDAU	Level-3-260C-168 HR	-40 to 105	T65218D0
TPS65218D0RSLT.A	Active	Production	VQFN (RSL) 48	250 SMALL T&R	Yes	NIPDAU	Level-3-260C-168 HR	-40 to 105	T65218D0
TPS65218D0RSLTG4	Active	Production	VQFN (RSL) 48	250 SMALL T&R	Yes	NIPDAU	Level-3-260C-168 HR	-40 to 105	T65218D0
TPS65218D0RSLTG4.A	Active	Production	VQFN (RSL) 48	250 SMALL T&R	Yes	NIPDAU	Level-3-260C-168 HR	-40 to 105	T65218D0

(1) **Status:** For more details on status, see our [product life cycle](#).

(2) **Material type:** When designated, preproduction parts are prototypes/experimental devices, and are not yet approved or released for full production. Testing and final process, including without limitation quality assurance, reliability performance testing, and/or process qualification, may not yet be complete, and this item is subject to further changes or possible discontinuation. If available for ordering, purchases will be subject to an additional waiver at checkout, and are intended for early internal evaluation purposes only. These items are sold without warranties of any kind.

(3) **RoHS values:** Yes, No, RoHS Exempt. See the [TI RoHS Statement](#) for additional information and value definition.

(4) **Lead finish/Ball material:** Parts may have multiple material finish options. Finish options are separated by a vertical ruled line. Lead finish/Ball material values may wrap to two lines if the finish value exceeds the maximum column width.

(5) **MSL rating/Peak reflow:** The moisture sensitivity level ratings and peak solder (reflow) temperatures. In the event that a part has multiple moisture sensitivity ratings, only the lowest level per JEDEC standards is shown. Refer to the shipping label for the actual reflow temperature that will be used to mount the part to the printed circuit board.

(6) **Part marking:** There may be an additional marking, which relates to the logo, the lot trace code information, or the environmental category of the part.

Multiple part markings will be inside parentheses. Only one part marking contained in parentheses and separated by a "-" will appear on a part. If a line is indented then it is a continuation of the previous line and the two combined represent the entire part marking for that device.

Important Information and Disclaimer: The information provided on this page represents TI's knowledge and belief as of the date that it is provided. TI bases its knowledge and belief on information provided by third parties, and makes no representation or warranty as to the accuracy of such information. Efforts are underway to better integrate information from third parties. TI has taken and continues to take reasonable steps to provide representative and accurate information but may not have conducted destructive testing or chemical analysis on incoming materials and chemicals. TI and TI suppliers consider certain information to be proprietary, and thus CAS numbers and other limited information may not be available for release.

In no event shall TI's liability arising out of such information exceed the total purchase price of the TI part(s) at issue in this document sold by TI to Customer on an annual basis.

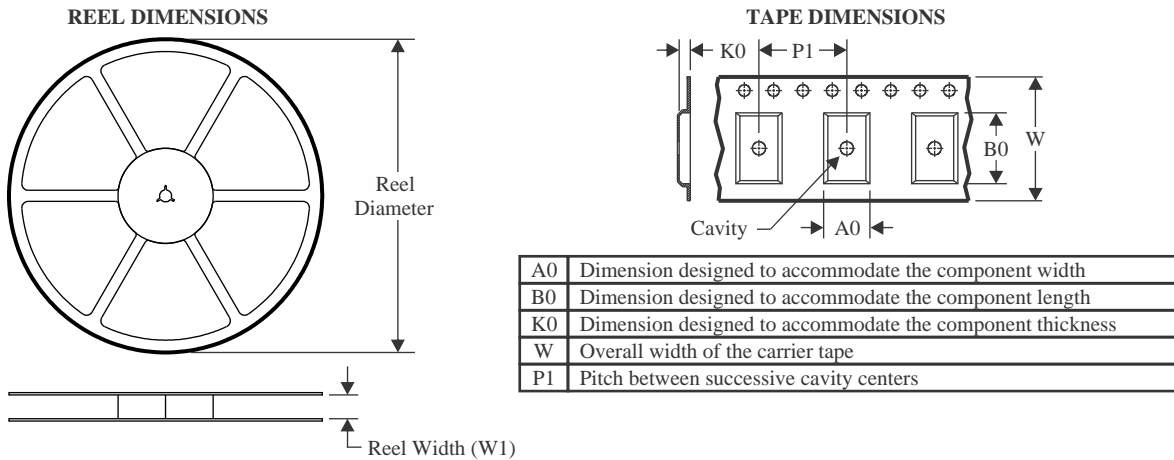
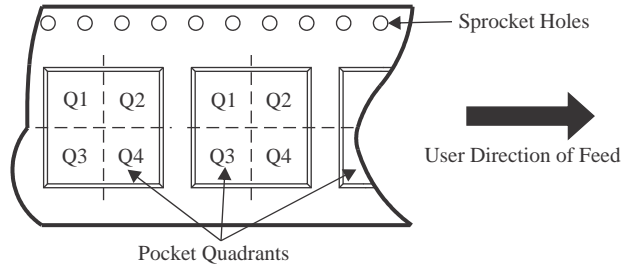
TAPE AND REEL INFORMATION

QUADRANT ASSIGNMENTS FOR PIN 1 ORIENTATION IN TAPE

*All dimensions are nominal

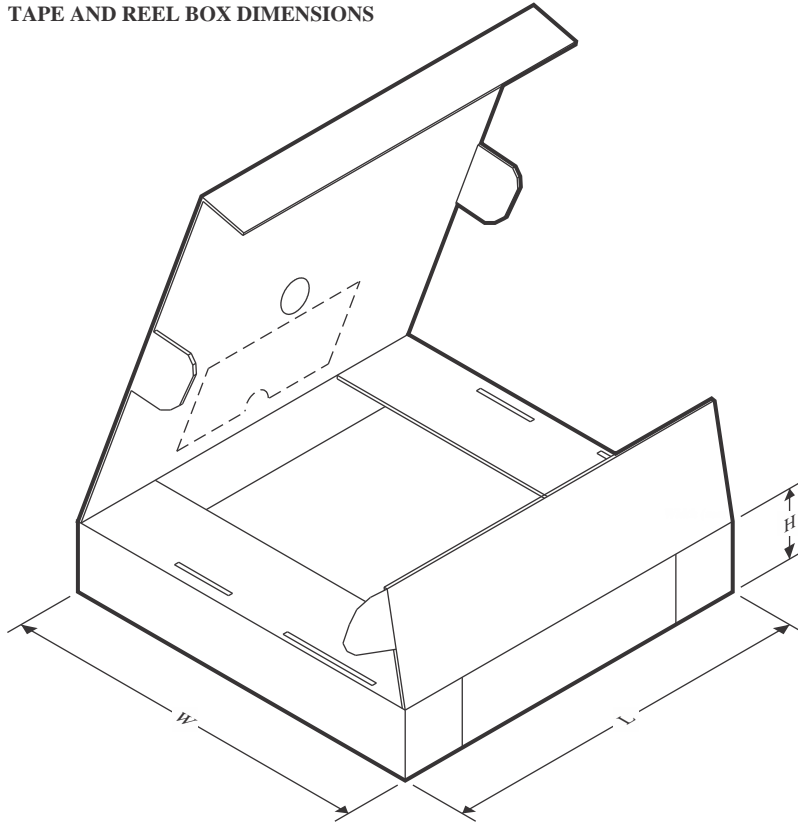
Device	Package Type	Package Drawing	Pins	SPQ	Reel Diameter (mm)	Reel Width W1 (mm)	A0 (mm)	B0 (mm)	K0 (mm)	P1 (mm)	W (mm)	Pin1 Quadrant
TPS65218D0PHPR	HTQFP	PHP	48	1000	330.0	16.4	9.6	9.6	1.5	12.0	16.0	Q2
TPS65218D0PHPT	HTQFP	PHP	48	250	330.0	16.4	9.6	9.6	1.5	12.0	16.0	Q2
TPS65218D0PHPTG4	HTQFP	PHP	48	250	330.0	16.4	9.6	9.6	1.5	12.0	16.0	Q2
TPS65218D0RSLR	VQFN	RSL	48	2500	330.0	16.4	6.3	6.3	1.1	12.0	16.0	Q2
TPS65218D0RSLT	VQFN	RSL	48	250	180.0	16.4	6.3	6.3	1.1	12.0	16.0	Q2
TPS65218D0RSLTG4	VQFN	RSL	48	250	180.0	16.4	6.3	6.3	1.1	12.0	16.0	Q2

TAPE AND REEL BOX DIMENSIONS

*All dimensions are nominal

Device	Package Type	Package Drawing	Pins	SPQ	Length (mm)	Width (mm)	Height (mm)
TPS65218D0PHPR	HTQFP	PHP	48	1000	336.6	336.6	31.8
TPS65218D0PHPT	HTQFP	PHP	48	250	336.6	336.6	31.8
TPS65218D0PHPTG4	HTQFP	PHP	48	250	336.6	336.6	31.8
TPS65218D0RSLR	VQFN	RSL	48	2500	367.0	367.0	38.0
TPS65218D0RSLT	VQFN	RSL	48	250	210.0	185.0	35.0
TPS65218D0RSLTG4	VQFN	RSL	48	250	210.0	185.0	35.0

GENERIC PACKAGE VIEW

RSL 48

VQFN - 1 mm max height

6 x 6, 0.4 mm pitch

QUAD FLATPACK - NO LEAD

This image is a representation of the package family, actual package may vary.
Refer to the product data sheet for package details.

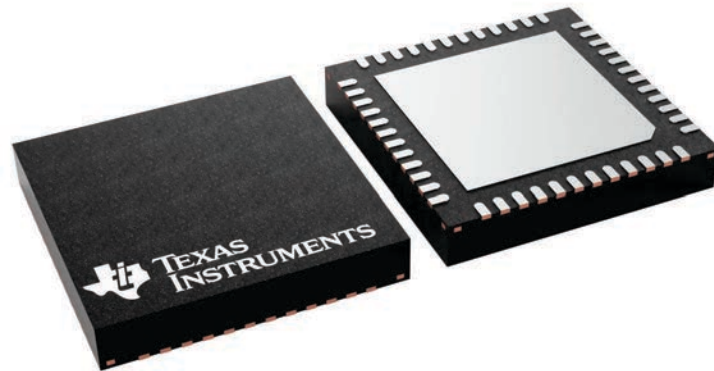

4225749/A

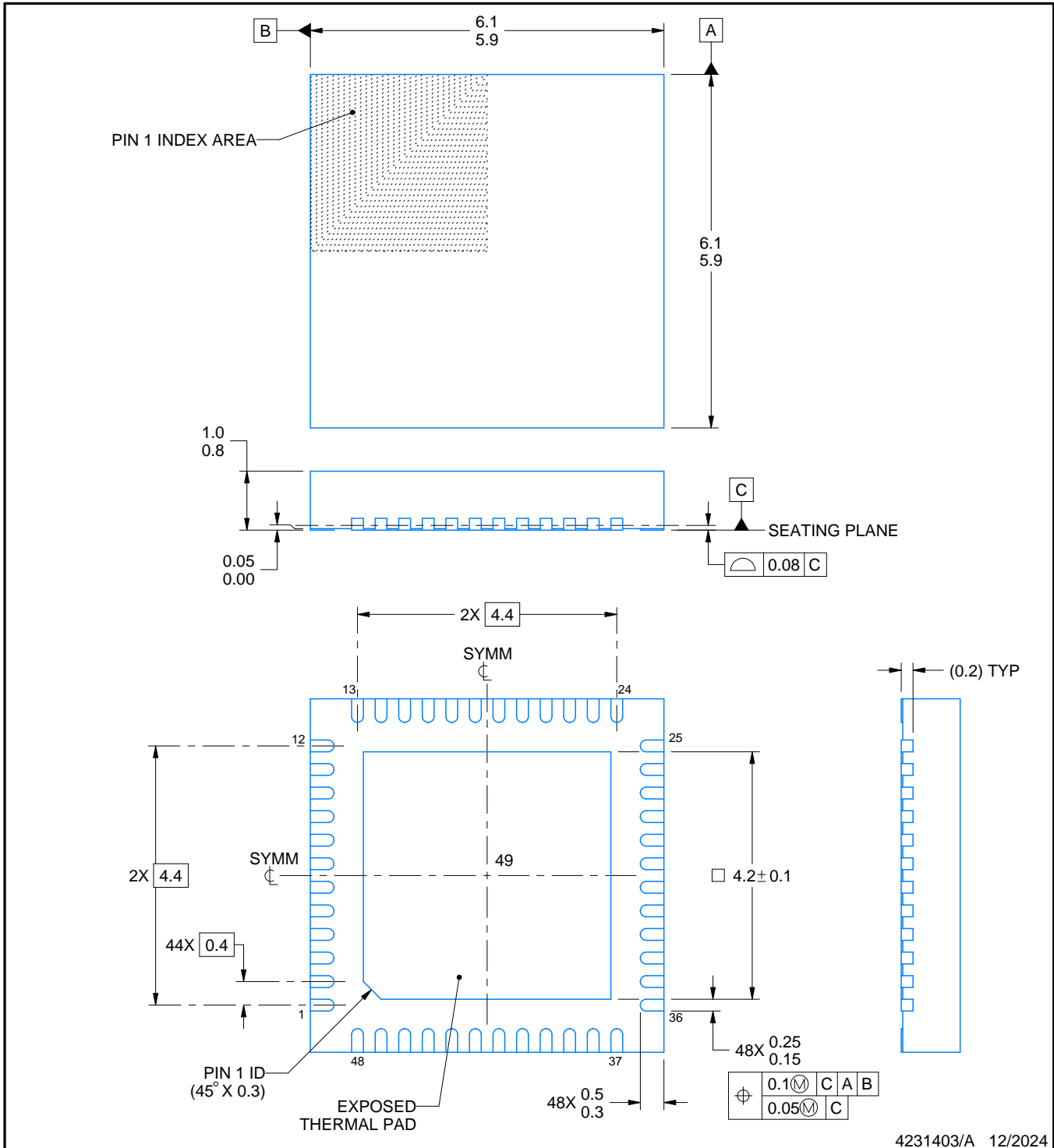
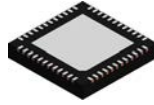

NOTES:

1. All linear dimensions are in millimeters. Any dimensions in parenthesis are for reference only. Dimensioning and tolerancing per ASME Y14.5M.
2. This drawing is subject to change without notice.
3. The package thermal pad must be soldered to the printed circuit board for thermal and mechanical performance.

EXAMPLE BOARD LAYOUT

RSL0048G

VQFN - 1 mm max height

PLASTIC QUAD FLATPACK - NO LEAD

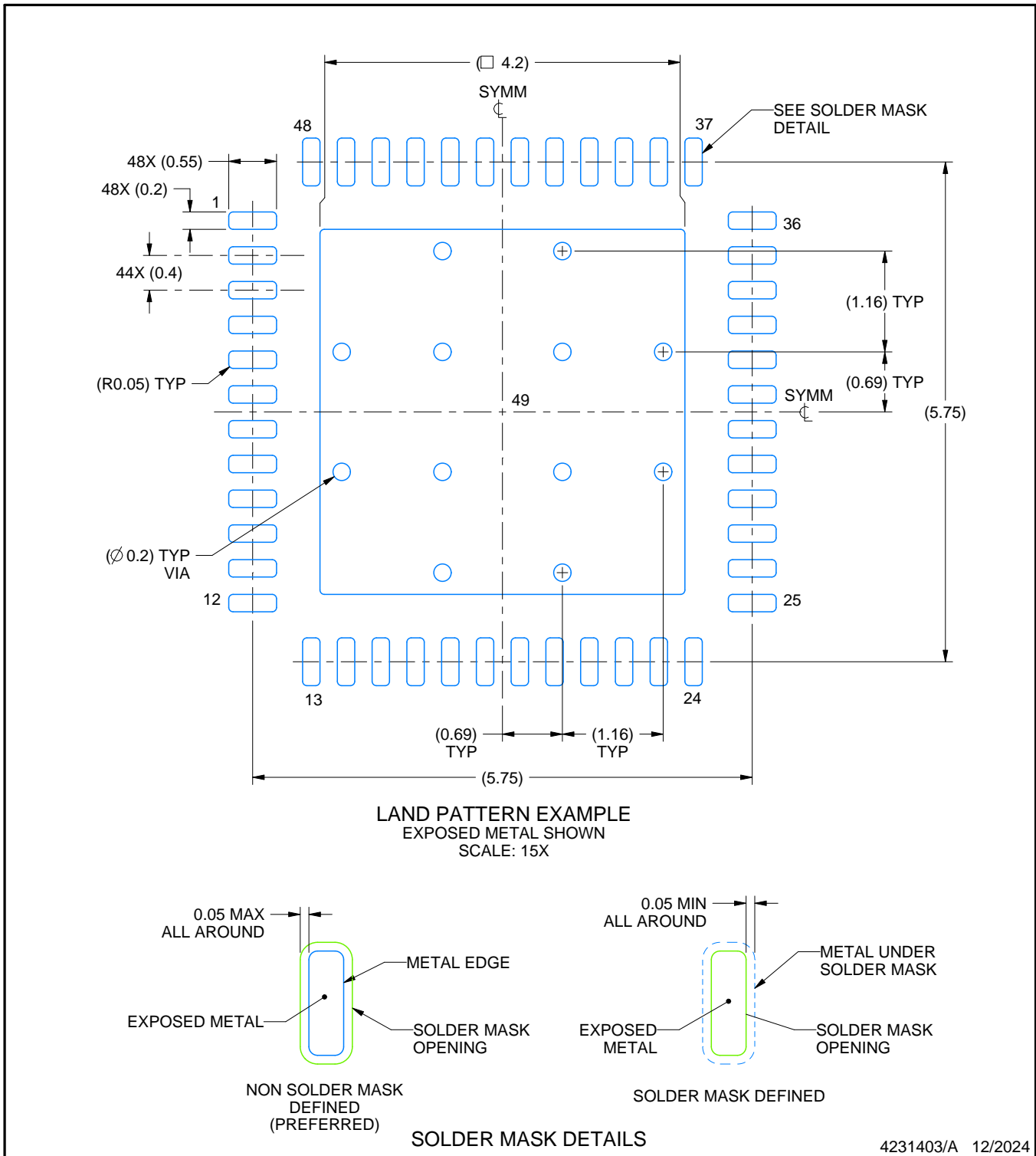

NOTES: (continued)

4. This package is designed to be soldered to a thermal pad on the board. For more information, see Texas Instruments literature number SLUA271 (www.ti.com/lit/slua271).
5. Vias are optional depending on application, refer to device data sheet. If any vias are implemented, refer to their locations shown on this view. It is recommended that vias under paste be filled, plugged or tented.

GENERIC PACKAGE VIEW

PHP 48

TQFP - 1.2 mm max height

7 x 7, 0.5 mm pitch

QUAD FLATPACK

This image is a representation of the package family, actual package may vary.
Refer to the product data sheet for package details.

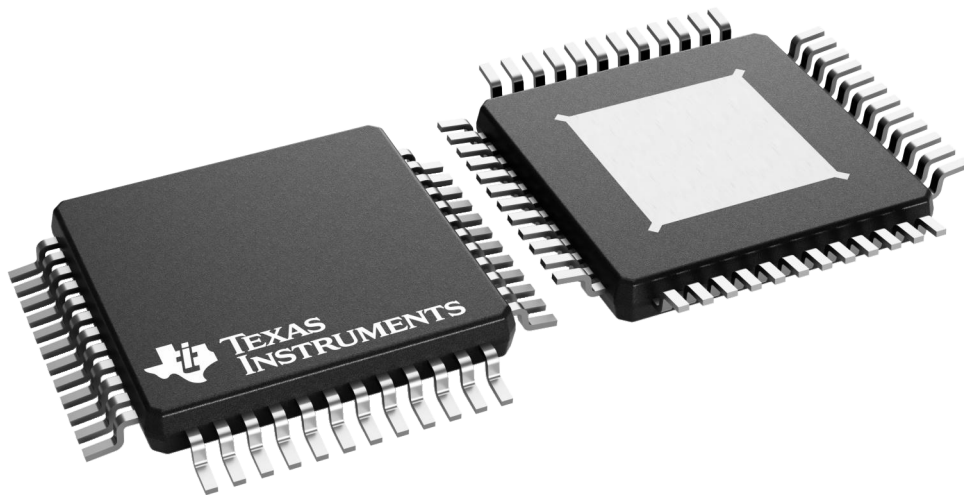

4226443/A

PHP0048M



PACKAGE OUTLINE

PowerPAD™ HTQFP - 1.2 mm max height

PLASTIC QUAD FLATPACK

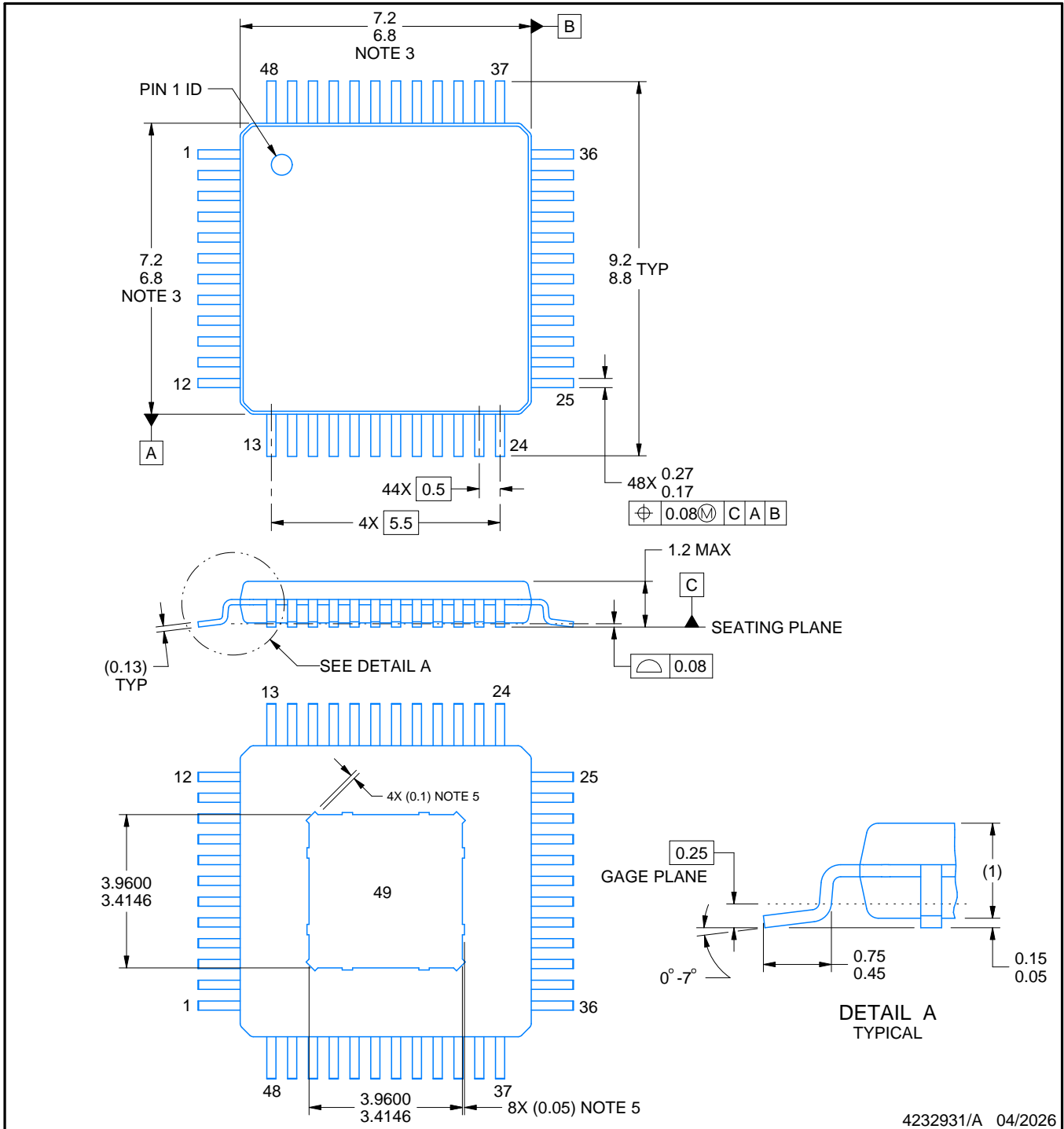

4232931/A 04/2026

NOTES:

PowerPAD is a trademark of Texas Instruments.

1. All linear dimensions are in millimeters. Any dimensions in parenthesis are for reference only. Dimensioning and tolerancing per ASME Y14.5M.
2. This drawing is subject to change without notice.
3. This dimension does not include mold flash, protrusions, or gate burrs. Mold flash, protrusions, or gate burrs shall not exceed 0.15 mm per side.
4. Reference JEDEC registration MS-026.
5. Feature may not be present.

EXAMPLE BOARD LAYOUT

PHP0048M

PowerPAD™ HTQFP - 1.2 mm max height

PLASTIC QUAD FLATPACK

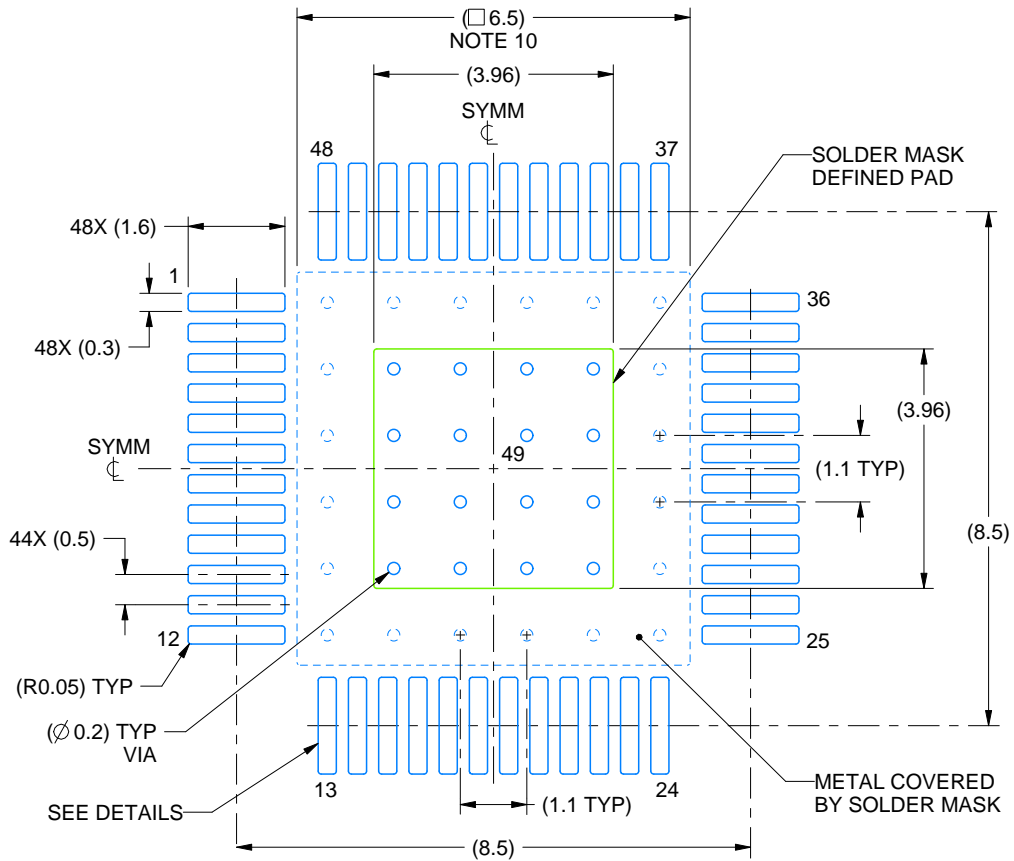

LAND PATTERN EXAMPLE
EXPOSED METAL SHOWN
SCALE:8X

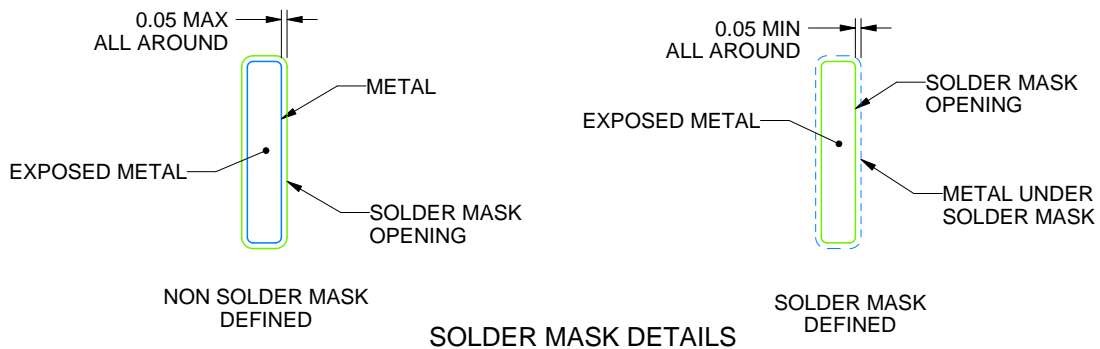

SOLDER MASK DETAILS

4232931/A 04/2026

NOTES: (continued)

6. Publication IPC-7351 may have alternate designs.
7. Solder mask tolerances between and around signal pads can vary based on board fabrication site.
8. This package is designed to be soldered to a thermal pad on the board. See technical brief, Powerpad thermally enhanced package, Texas Instruments Literature No. SLMA002 (www.ti.com/lit/slma002) and SLMA004 (www.ti.com/lit/slma004).
9. Vias are optional depending on application, refer to device data sheet. It is recommended that vias under paste be filled, plugged or tented.
10. Size of metal pad may vary due to creepage requirement.

EXAMPLE STENCIL DESIGN

PHP0048M

PowerPAD™ HTQFP - 1.2 mm max height

PLASTIC QUAD FLATPACK

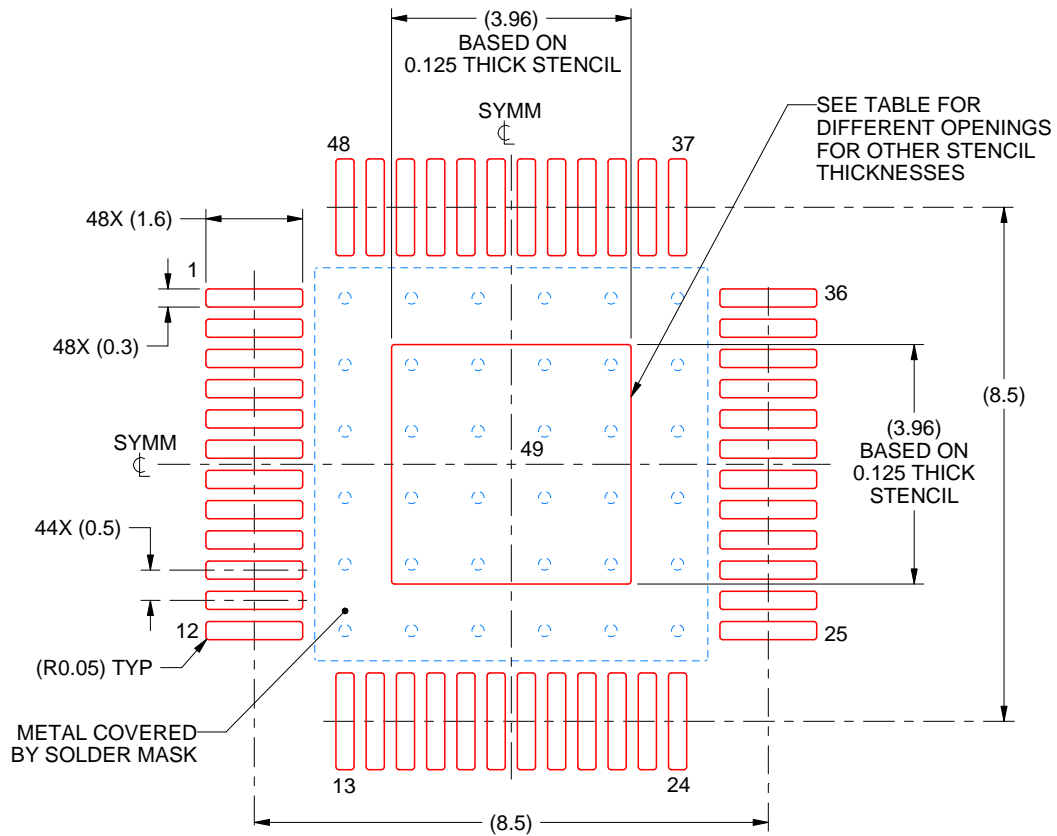

SOLDER PASTE EXAMPLE
EXPOSED PAD
100% PRINTED SOLDER COVERAGE BY AREA
SCALE:8X

STENCIL THICKNESS	SOLDER STENCIL OPENING
0.1	4.43 X 4.43
0.125	3.96 X 3.96 (SHOWN)
0.150	3.61 X 3.61
0.175	3.35 X 3.35

4232931/A 04/2026

NOTES: (continued)

- 11. Laser cutting apertures with trapezoidal walls and rounded corners may offer better paste release. IPC-7525 may have alternate design recommendations.
- 12. Board assembly site may have different recommendations for stencil design.

重要なお知らせと免責事項

TI は、技術データと信頼性データ (データシートを含みます)、設計リソース (リファレンス デザインを含みます)、アプリケーションや設計に関する各種アドバイス、Web ツール、安全性情報、その他のリソースを、欠陥が存在する可能性のある「現状のまま」提供しており、商品性および特定目的に対する適合性の黙示保証、第三者の知的財産権の非侵害保証を含むいかなる保証も、明示的または黙示的にかかわらず拒否します。

これらのリソースは、TI 製品を使用する設計の経験を積んだ開発者への提供を意図したものです。(1) お客様のアプリケーションに適した TI 製品の選定、(2) お客様のアプリケーションの設計、検証、試験、(3) お客様のアプリケーションに該当する各種規格や、その他のあらゆる安全性、セキュリティ、規制、または他の要件への確実な適合に関する責任を、お客様のみが単独で負うものとし、

上記の各種リソースは、予告なく変更される可能性があります。これらのリソースは、リソースで説明されている TI 製品を使用するアプリケーションの開発の目的でのみ、TI はその使用をお客様に許諾します。これらのリソースに関して、他の目的で複製することや掲載することは禁止されています。TI や第三者の知的財産権のライセンスが付与されている訳ではありません。お客様は、これらのリソースを自身で使用した結果発生するあらゆる申し立て、損害、費用、損失、責任について、TI およびその代理人を完全に補償するものとし、TI は一切の責任を拒否します。

TI の製品は、[TI の販売条件](#)、[TI の総合的な品質ガイドライン](#)、[ti.com](#) または TI 製品などに関連して提供される他の適用条件に従い提供されます。TI がこれらのリソースを提供することは、適用される TI の保証または他の保証の放棄の拡大や変更を意味するものではありません。TI がカスタム、またはカスタマー仕様として明示的に指定していない限り、TI の製品は標準的なカタログに掲載される汎用機器です。

お客様がいかなる追加条項または代替条項を提案する場合も、TI はそれらに異議を唱え、拒否します。

Copyright © 2026, Texas Instruments Incorporated

最終更新日 : 2025 年 10 月