

# ATL43x 2.5V、低 I<sub>q</sub>、可変、高精度シャントレギュレータ

## 1 特長

- 2.5V ~ 36V の調整可能なレギュレーション済み出力
- 非常に小さい動作時電流
  - I<sub>KA(min)</sub> = 35μA (最大値)
  - I<sub>REF</sub> = 150nA (最大値)
- 安定性を実現する内部補償
  - 容量性負荷なしで安定
- 25°Cでの基準電圧の許容公差
  - 0.5% (B グレード)
  - 1% (A グレード)
- 標準の温度ドリフト
  - 5mV (–40°C ~ +85°C)、I バージョン
  - 6mV (–40°C ~ +125°C)、Q バージョン
- カソード電流範囲を拡大  
35μA ~ 100mA
- 小さい出力インピーダンス: 0.3Ω (最大値)

## 2 アプリケーション

- フライバック SMPS の 2 次側レギュレーション
- 産業用、コンピューティング、コンシューマ、ポータブル
- 可変の基準電圧および電流
- パワー マネージメント
- 電源の絶縁
- ツェナーの代替品

## 3 概要

ATL431 と ATL432 は、3 ピンの可変シャントレギュレータで、該当する車載用、商業用、工業用の温度範囲の全体にわたって、規定された熱安定性を維持します。出力電圧は、2 つの外付け抵抗を使用して、V<sub>ref</sub> (約 2.5V) から 36V までの範囲で任意の値に設定できます。これらのデバイスの出力インピーダンスは 0.05Ω (標準値) です。これらのデバイスは、アクティブ出力回路による非常に鋭いターンオン特性を備えているため、オンボードレギュレーション、可変電源、スイッチング電源など、多くのアプリケーションにおいて、ツェナーダイオードの優れた代替品となります。

ATL43x は、前世代の TL43x に比べてカソード電流範囲が 20 倍以上改善されています。また、より広い範囲の負荷容量のタイプと値でも安定して動作します。

ATL431 と ATL432 はまったく同じ部品ですが、ピン配置と注文番号が異なります。ATL43x は、初期公差 (25°C 時) が 0.5% の B グレードと、1% の A グレードの 2 つのグレードで供給されます。さらに、温度による出力ドリフトの変動が小さいため、温度範囲全体にわたって定電圧レギュレーションが保証されます。

ATL43xxI デバイスは –40°C ~ +85°C、ATL43xxQ デバイスは –40°C ~ +125°C の温度範囲で動作が規定されています。

### 製品情報

部品番号	パッケージ (1)	本体サイズ (公称)(2)
ATL431 ATL432	SOT (3)	2.90mm × 1.60mm

- (1) 利用可能なすべてのパッケージについては、データシートの末尾にある注文情報を参照してください。
- (2) パッケージサイズ (長さ × 幅) は公称値で、該当する場合はピンも含まれます。

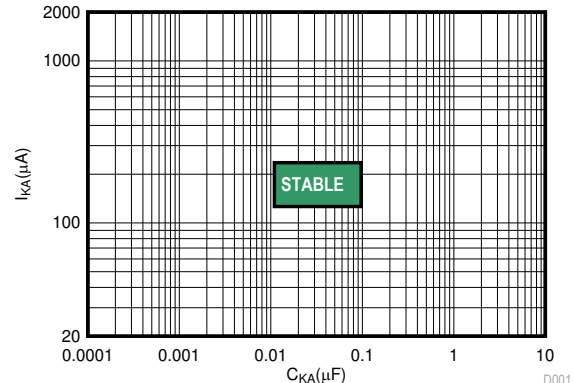

V<sub>KA</sub> の安定領域 = 15V

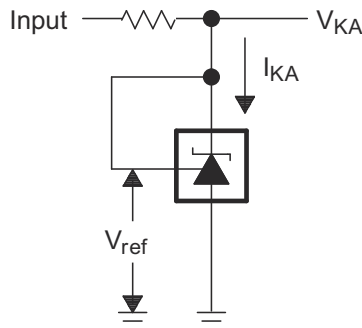

Copyright © 2017, Texas Instruments Incorporated

概略回路図



## Table of Contents

<b>1 特長</b> .....	1	7.4 Device Functional Modes.....	14
<b>2 アプリケーション</b> .....	1	<b>8 Application and Implementation</b> .....	15
<b>3 概要</b> .....	1	8.1 Application Information.....	15
<b>4 Pin Configuration and Functions</b> .....	3	8.2 Typical Applications.....	16
<b>5 Specifications</b> .....	3	<b>9 Power Supply Recommendations</b> .....	21
5.1 Absolute Maximum Ratings.....	3	<b>10 Layout</b> .....	21
5.2 ESD Ratings.....	3	10.1 Layout Guidelines.....	21
5.3 Recommended Operating Conditions.....	3	10.2 Layout Example.....	21
5.4 Thermal Information.....	4	<b>11 Device and Documentation Support</b> .....	22
5.5 Electrical Characteristics, ATL431Ax, ATL432Ax.....	4	11.1 ドキュメントの更新通知を受け取る方法.....	22
5.6 Electrical Characteristics, ATL431Bx, ATL432Bx.....	4	11.2 サポート・リソース.....	22
5.7 Typical Characteristics.....	6	11.3 Trademarks.....	22
<b>6 Parameter Measurement Information</b> .....	11	11.4 静電気放電に関する注意事項.....	22
<b>7 Detailed Description</b> .....	13	11.5 用語集.....	22
7.1 Overview.....	13	<b>12 Revision History</b> .....	23
7.2 Functional Block Diagram.....	13	<b>13 Mechanical, Packaging, and Orderable Information</b> .....	23
7.3 Feature Description.....	13		

## 4 Pin Configuration and Functions



図 4-1. ATL431 DBZ Package  
3-Pin SOT-23  
Top View



図 4-2. ATL432 DBZ Package  
3-Pin SOT-23  
Top View

表 4-1. Pin Functions

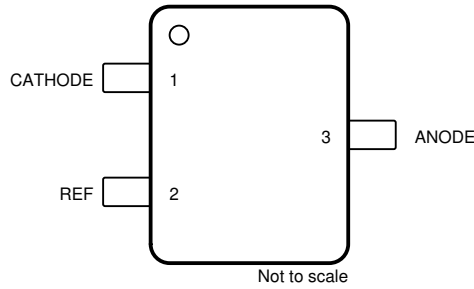
NAME	PIN		I/O	DESCRIPTION
	NO.			
	ATL431x	ATL432x		
CATHODE	1	2	I/O	Shunt Current/Voltage input
REF	2	1	I	Threshold relative to common anode
ANODE	3	3	O	Common pin, normally connected to ground

## 5 Specifications

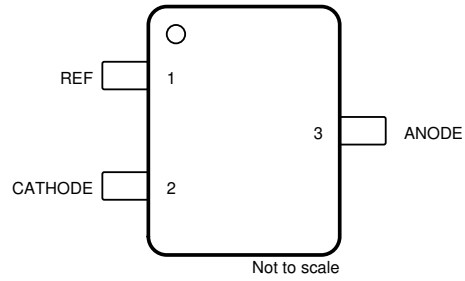
### 5.1 Absolute Maximum Ratings

over operating free-air temperature range (unless otherwise noted)<sup>(1)</sup>

		MIN	MAX	UNIT
$V_{KA}$	Cathode voltage <sup>(2)</sup>		40	V
$I_{KA}$	Continuous cathode current	-100	150	mA
$I_{I(ref)}$	Reference input current	-0.05	10	mA
$T_J$	Operating virtual junction temperature	-40	150	°C
$T_{stg}$	Storage temperature	-65	150	°C

- (1) Stresses beyond those listed under *Absolute Maximum Ratings* may cause permanent damage to the device. These are stress ratings only, and functional operation of the device at these or any other conditions beyond those indicated under *Recommended Operating Conditions* is not implied. Exposure to absolute-maximum-rated conditions for extended periods may affect device reliability.
- (2) All voltage values are with respect to ANODE, unless otherwise noted.

### 5.2 ESD Ratings

		VALUE	UNIT
$V_{(ESD)}$	Electrostatic discharge	Human-body model (HBM), per ANSI/ESDA/JEDEC JS-001 <sup>(1)</sup>	±2000
		Charged-device model (CDM), per JEDEC specification JESD22-C101 <sup>(2)</sup>	±1000

- (1) JEDEC document JEP155 states that 500V HBM allows safe manufacturing with a standard ESD control process.
- (2) JEDEC document JEP157 states that 250V CDM allows safe manufacturing with a standard ESD control process.

### 5.3 Recommended Operating Conditions

		MIN	MAX	UNIT
$V_{KA}$	Cathode voltage	$V_{ref}$	36	V
$I_{KA}$	Cathode current	.035	100	mA

		MIN	MAX	UNIT	
T <sub>A</sub>	Operating free-air temperature	I Grade	-40	85	°C
		Q Grade	-40	125	

### 5.4 Thermal Information

THERMAL METRIC <sup>(1)</sup>		ATL43x	UNIT
		DBZ (SOT-23)	
		3 PINS	
R <sub>θJA</sub>	Junction-to-ambient thermal resistance	331.8	°C/W
R <sub>θJC(top)</sub>	Junction-to-case (top) thermal resistance	106.5	°C/W
R <sub>θJB</sub>	Junction-to-board thermal resistance	64.6	°C/W
ψ <sub>JT</sub>	Junction-to-top characterization parameter	4.9	°C/W
ψ <sub>JB</sub>	Junction-to-board characterization parameter	62.9	°C/W

(1) For more information about traditional and new thermal metrics, see the [Semiconductor and IC Package Thermal Metrics](#) application report.

### 5.5 Electrical Characteristics, ATL431Ax, ATL432Ax

over recommended operating conditions, T<sub>A</sub> = 25°C (unless otherwise noted)

PARAMETER	TEST CIRCUIT	TEST CONDITIONS	MIN	TYP	MAX	UNIT		
V <sub>ref</sub>	Reference voltage	☒ 6-1	V <sub>KA</sub> = V <sub>ref</sub> , I <sub>KA</sub> = 1mA		2475	2500	2525	mV
V <sub>I(dev)</sub>	Deviation of reference input voltage over full temperature range, see section	☒ 6-1	V <sub>KA</sub> = V <sub>ref</sub> , I <sub>KA</sub> = 1mA,	ATL43xAI; T <sub>A</sub> = -40°C to 85°C	5	15	mV	
				ATL43xAQ; T <sub>A</sub> = -40°C to 125°C	6	34		
ΔV <sub>ref</sub> / ΔV <sub>KA</sub>	Ratio of change in reference voltage to the change in cathode voltage	☒ 6-2	I <sub>KA</sub> = 1mA	ΔV <sub>KA</sub> = 10V - V <sub>ref</sub>	-0.4	-2.7	mV/V	
				ΔV <sub>KA</sub> = 36V - 10V	-0.1	-2		
I <sub>ref</sub>	Reference input current	☒ 6-2	I <sub>KA</sub> = 1mA, R1 = 10kΩ, R2 = ∞		30	150	nA	
I <sub>I(dev)</sub>	Deviation of reference input current over full temperature range, see section	☒ 6-2	I <sub>KA</sub> = 1mA, R1 = 10kΩ, R2 = ∞		20	50	nA	
I <sub>min</sub>	Minimum cathode current for regulation	☒ 6-1 ☒ 5-5	V <sub>KA</sub> = V <sub>ref</sub>		20	35	μA	
I <sub>off</sub>	Off-state cathode current	☒ 6-3	V <sub>KA</sub> = 36V, V <sub>ref</sub> = 0		0.05	0.2	μA	
Z <sub>KA</sub>	Dynamic impedance, see section	☒ 6-1	V <sub>KA</sub> = V <sub>ref</sub> , f ≤ 1 kHz, I <sub>KA</sub> = 1 mA to 100 mA		0.05	0.3	Ω	

### 5.6 Electrical Characteristics, ATL431Bx, ATL432Bx

over recommended operating conditions, T<sub>A</sub> = 25°C (unless otherwise noted)

PARAMETER	TEST CIRCUIT	TEST CONDITIONS	MIN	TYP	MAX	UNIT		
V <sub>ref</sub>	Reference voltage	☒ 6-1	V <sub>KA</sub> = V <sub>ref</sub> , I <sub>KA</sub> = 1mA		2487	2500	2512	mV
V <sub>I(dev)</sub>	Deviation of reference input voltage over full temperature range, see section	☒ 6-1	V <sub>KA</sub> = V <sub>ref</sub> , I <sub>KA</sub> = 1mA	ATL43xBI; T <sub>A</sub> = -40°C to 85°C	5	15	mV	
				ATL43xBQ; T <sub>A</sub> = -40°C to 125°C	6	34		
ΔV <sub>ref</sub> / ΔV <sub>KA</sub>	Ratio of change in reference voltage to the change in cathode voltage	☒ 6-2	I <sub>KA</sub> = 1mA	ΔV <sub>KA</sub> = 10V - V <sub>ref</sub>	-0.4	-2.7	mV/V	
				ΔV <sub>KA</sub> = 36V - 10V	-0.1	-2		
I <sub>ref</sub>	Reference input current	☒ 6-2	I <sub>KA</sub> = 1mA, R1 = 10kΩ, R2 = ∞		30	150	nA	
I <sub>I(dev)</sub>	Deviation of reference input current over full temperature range, see section	☒ 6-2	I <sub>KA</sub> = 1mA, R1 = 10kΩ, R2 = ∞		20	50	nA	
I <sub>min</sub>	Minimum cathode current for regulation	☒ 6-1 ☒ 5-5	V <sub>KA</sub> = V <sub>ref</sub>		20	35	μA	
I <sub>off</sub>	Off-state cathode current	☒ 6-3	V <sub>KA</sub> = 36V, V <sub>ref</sub> = 0		0.05	0.2	μA	

## 5.6 Electrical Characteristics, ATL431Bx, ATL432Bx (続き)

over recommended operating conditions,  $T_A = 25^\circ\text{C}$  (unless otherwise noted)

PARAMETER		TEST CIRCUIT	TEST CONDITIONS	MIN	TYP	MAX	UNIT
$ z_{KA} $	Dynamic impedance, see section	 6-1	$V_{KA} = V_{ref}$ , $f \leq 1 \text{ kHz}$ , $I_{KA} = 1 \text{ mA to } 100 \text{ mA}$		0.05	0.3	$\Omega$

## 5.7 Typical Characteristics

Data at high and low temperatures are applicable only within the recommended operating free-air temperature ranges of the various devices.

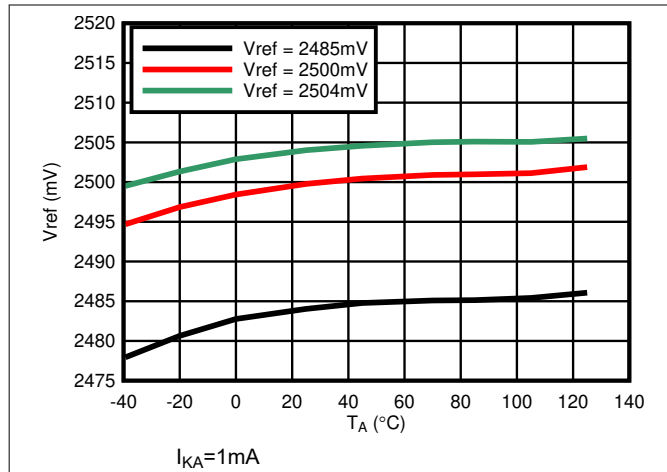

Figure 5-1. Reference Voltage vs Free-Air Temperature

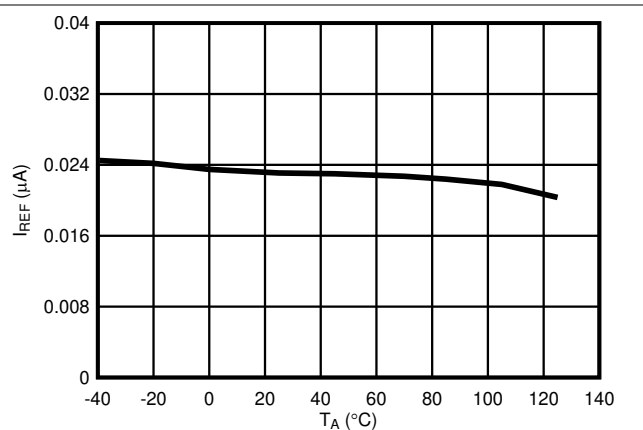

Figure 5-2. Reference Current vs Free-Air Temperature

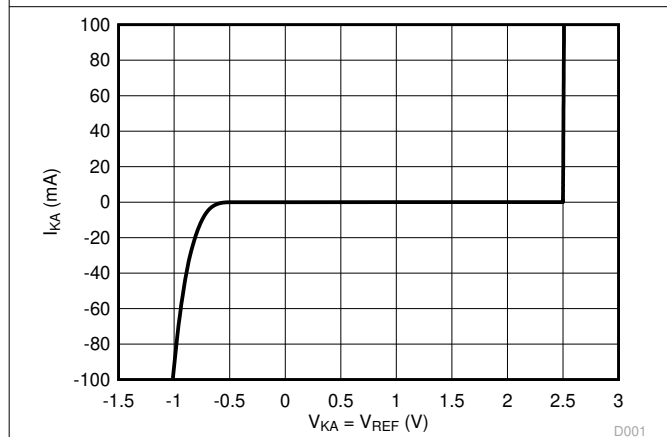

Figure 5-3. Cathode Current vs Cathode Voltage

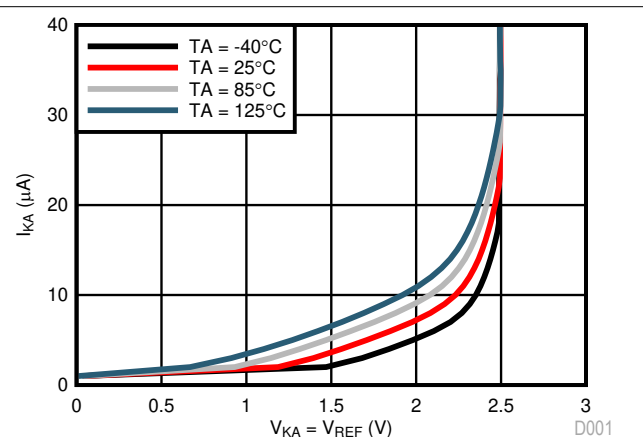

Figure 5-4. Cathode Current vs Cathode Voltage

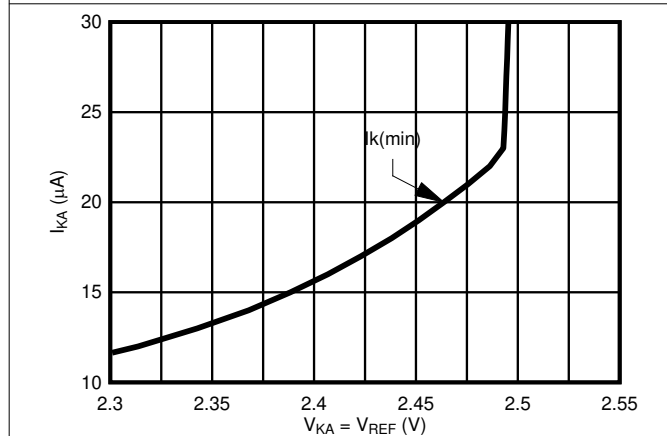

Figure 5-5. Cathode Current vs Cathode Voltage

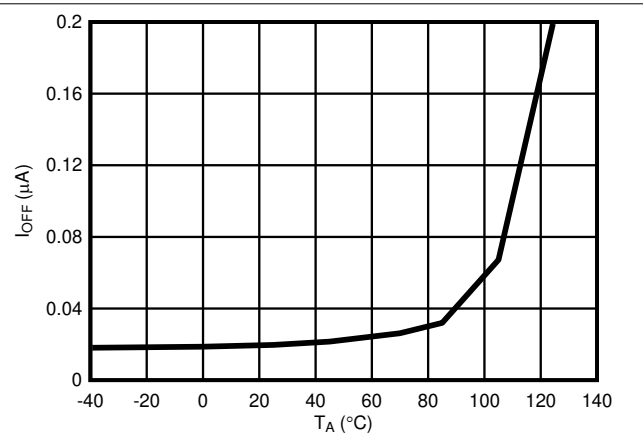
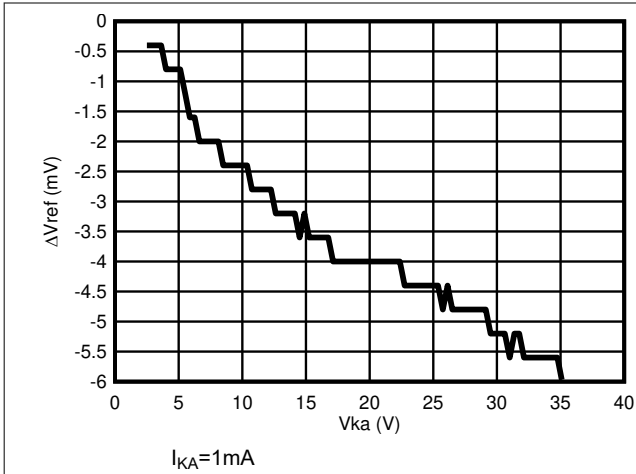

Figure 5-6. Off-State Cathode Current vs Free-Air Temperature

### 5.7 Typical Characteristics (continued)

Data at high and low temperatures are applicable only within the recommended operating free-air temperature ranges of the various devices.



5-7. Delta Reference Voltage vs Cathode Voltage

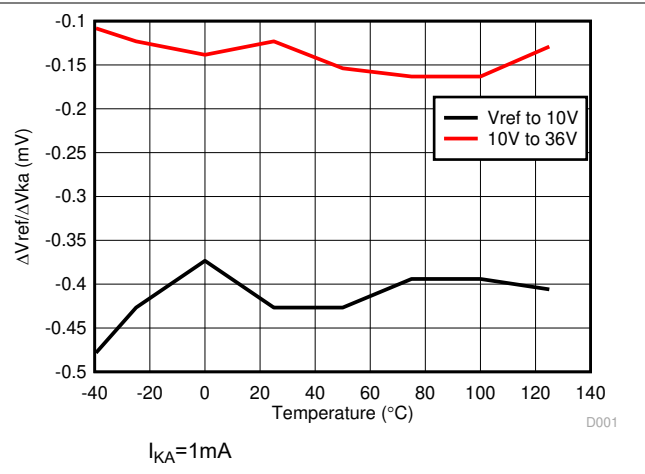

5-8. Delta Reference Voltage vs Cathode Voltage

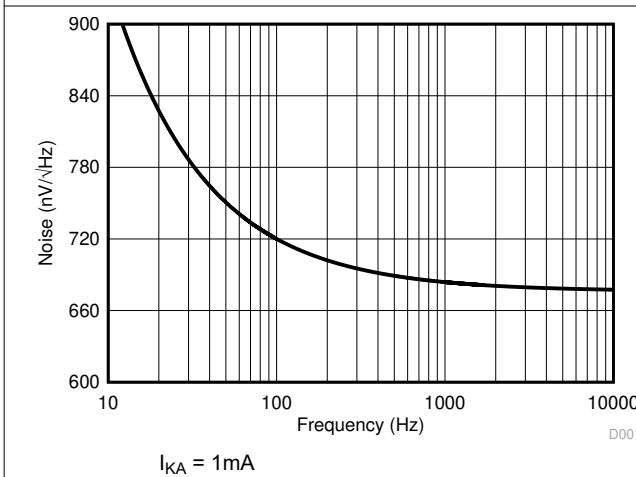

5-9. Noise Voltage

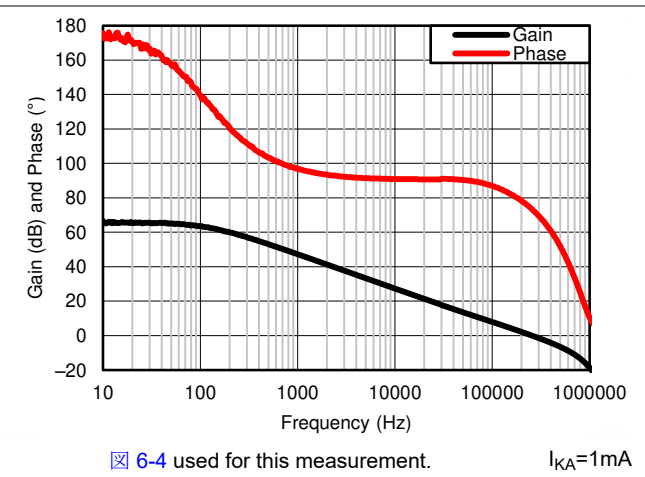

5-10. Small-Signal Voltage Amplification vs Frequency

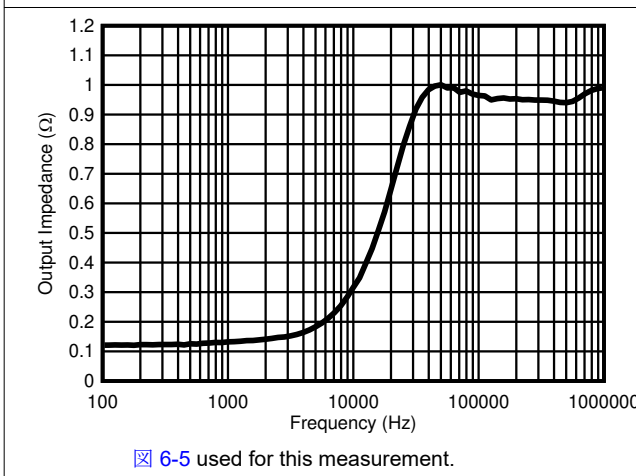

5-11. Output Impedance vs Frequency



5-12. DC Output Impedance vs Temperature

### 5.7 Typical Characteristics (continued)

Data at high and low temperatures are applicable only within the recommended operating free-air temperature ranges of the various devices.

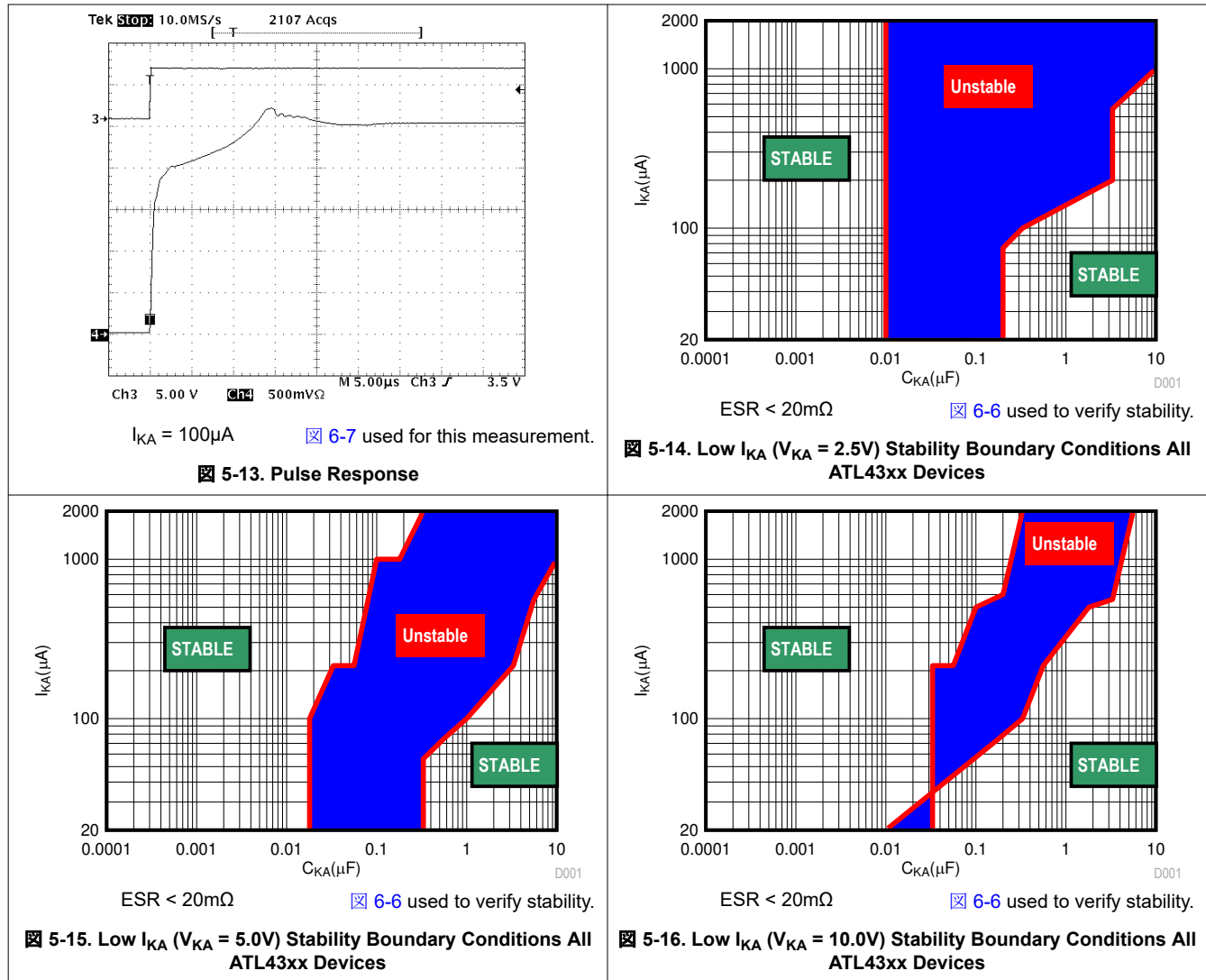

### 5.7 Typical Characteristics (continued)

Data at high and low temperatures are applicable only within the recommended operating free-air temperature ranges of the various devices.

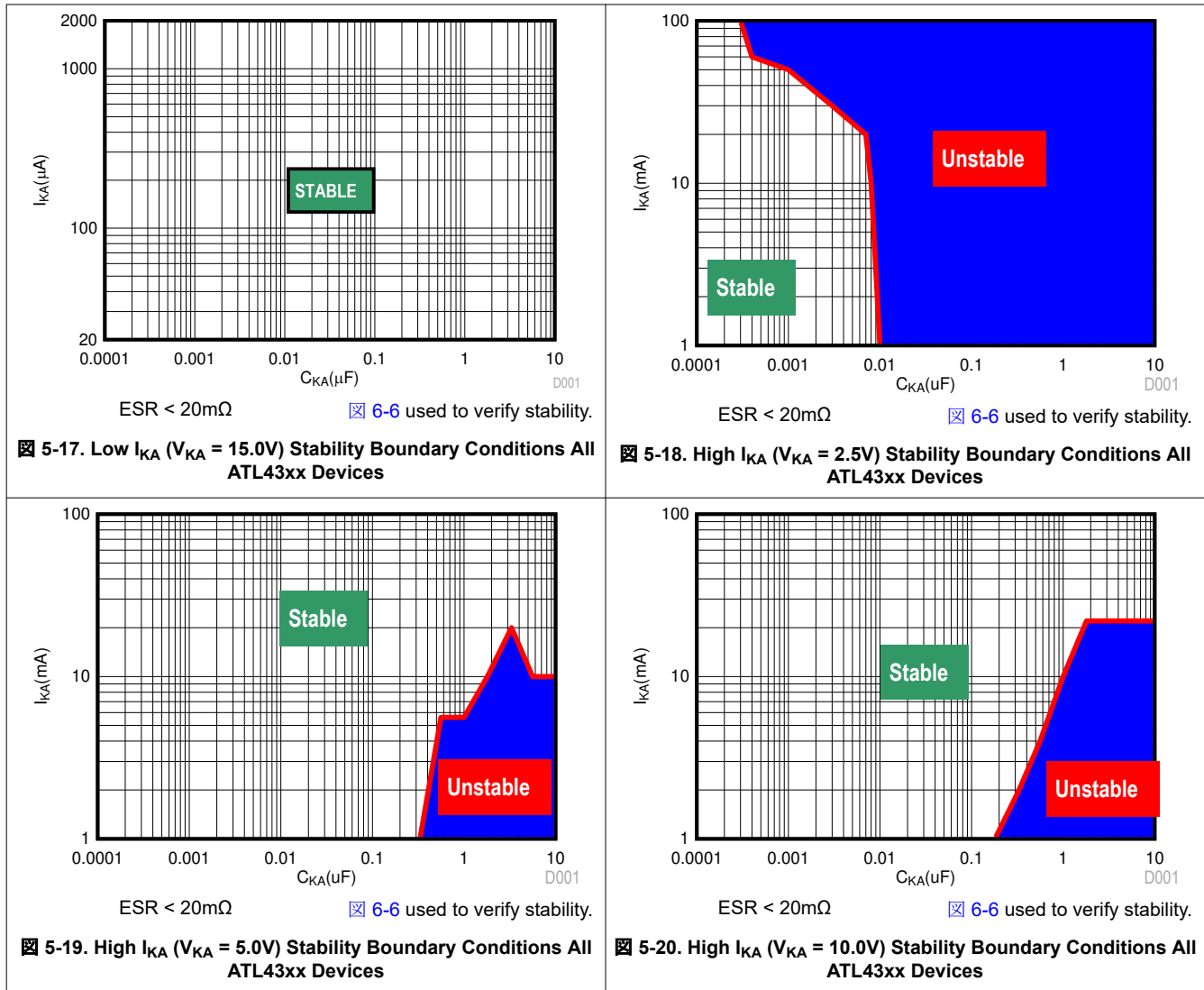

### 5.7 Typical Characteristics (continued)

Data at high and low temperatures are applicable only within the recommended operating free-air temperature ranges of the various devices.

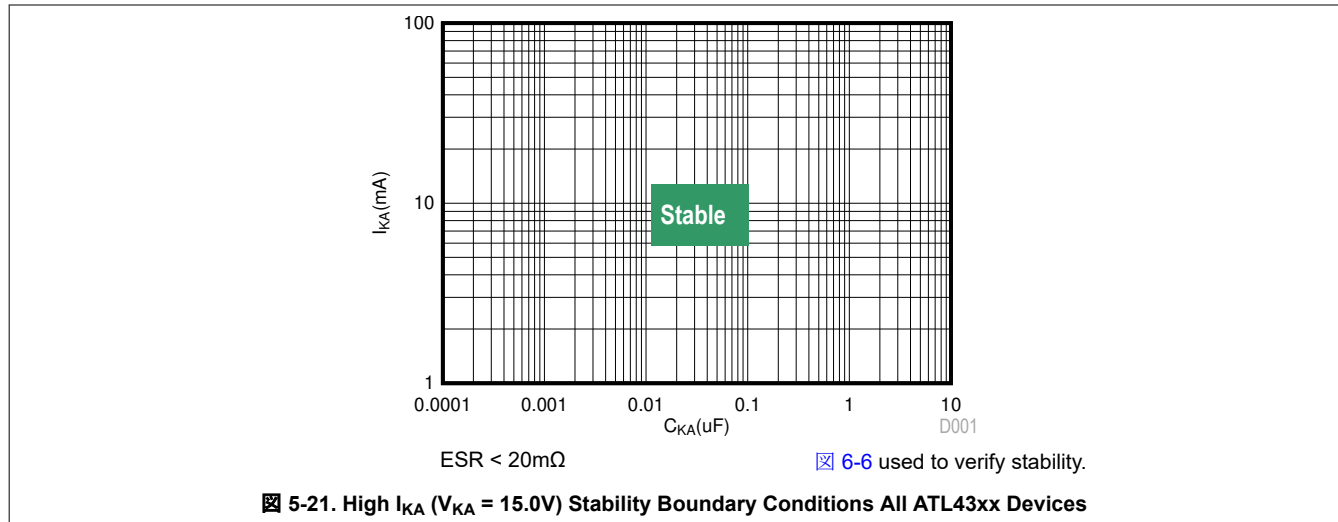

## 6 Parameter Measurement Information

The deviation parameters  $V_{ref(dev)}$  and  $I_{ref(dev)}$  are defined as the differences between the maximum and minimum values obtained over the rated temperature range. The average full-range temperature coefficient of the reference input voltage  $\alpha_{Vref}$  is defined as:

$$|\alpha_{Vref}| \left( \frac{ppm}{^{\circ}C} \right) = \frac{\left( \frac{V_{I(dev)}}{V_{ref \text{ at } 25^{\circ}C}} \right) \times 10^6}{\Delta T_A}$$

where:

$\Delta T_A$  is the rated operating temperature range of the device.

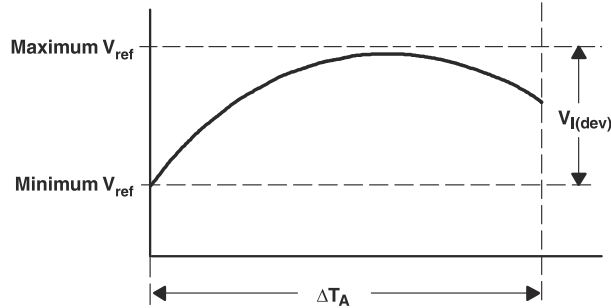

$\alpha_{Vref}$  is positive or negative, depending on whether minimum  $V_{ref}$  or maximum  $V_{ref}$ , respectively, occurs at the lower temperature.

The dynamic impedance is defined as:  $|z_{KA}| = \frac{\Delta V_{KA}}{\Delta I_{KA}}$

When the device is operating with two external resistors (see [Figure 6-2](#)), the total dynamic impedance of the circuit is given by:  $|z'| = \frac{\Delta V}{\Delta I}$  which is approximately equal to  $|z_{KA}| \left( 1 + \frac{R1}{R2} \right)$

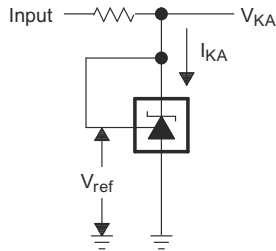

**Figure 6-1. Test Circuit for  $V_{KA} = V_{ref}$**

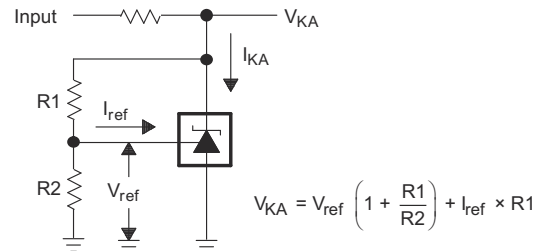

**Figure 6-2. Test Circuit for  $V_{KA} > V_{ref}$**



图 6-3. Test Circuit for  $I_{off}$



图 6-4. Test Circuit for Phase and Gain Measurement

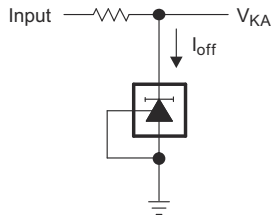

图 6-5. Test Circuit for Reference Impedance ( $Z_{KA}$ )

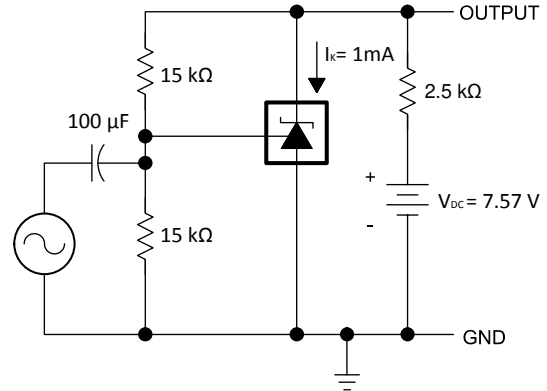

图 6-6. Test Circuit for Stability Boundary Conditions

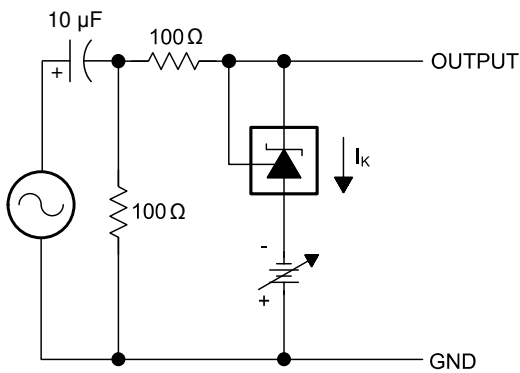

图 6-7. Test Circuit for Pulse Response

## 7 Detailed Description

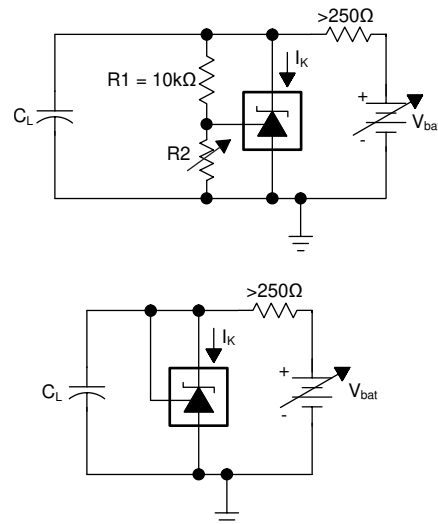
### 7.1 Overview

The ATL43x is a low power counterpart to TL431 and TLV431, having lower minimum cathode current ( $I_{k(\min)} = 35\mu\text{A}$ ). Like the TL431, the ATL43x is used in conjunction with its key components to behave as a single voltage reference, error amplifier, voltage clamp, or comparator with integrated reference.

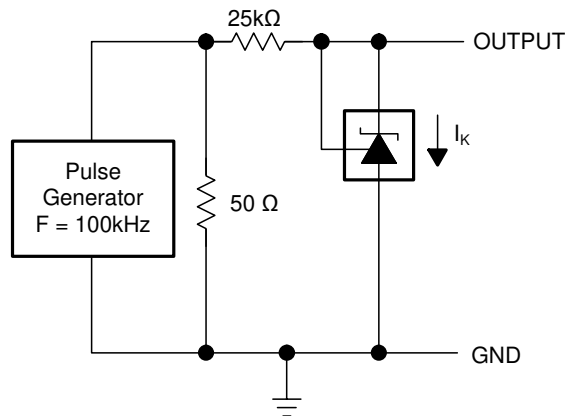
The ATL43x can be operated and adjusted to cathode voltages from 2.5V to 36V, this part is an excellent choice for a wide range of end equipments in industrial, auto, telecom and computing. For this device to behave as a shunt regulator or error amplifier,  $> 35\mu\text{A}$  ( $I_{\min(\max)}$ ) must be supplied in to the cathode pin. Under this condition, feedback can be applied from the Cathode and Ref pins to create a replica of the internal reference voltage.

Various reference voltage options can be purchased with initial tolerances (at 25°C) of 0.5% and 1.0%. These reference options are denoted by B (0.5%) and A (1.0%) after the ATL43x.

The ATL43xxl devices are characterized for operation from  $-40^{\circ}\text{C}$  to  $+85^{\circ}\text{C}$ , and the ATL43xxQ devices are characterized for operation from  $-40^{\circ}\text{C}$  to  $+125^{\circ}\text{C}$ .

### 7.2 Functional Block Diagram

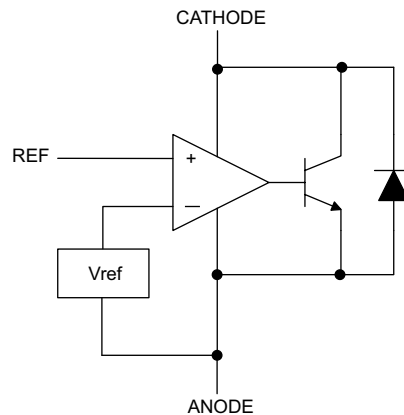

Copyright © 2017, Texas Instruments Incorporated

### 7.3 Feature Description

ATL43x consists of an internal reference and amplifier that outputs a sink current based on the difference between the reference pin and the virtual internal pin. The sink current is produced by an internal Darlington pair.

When operated with enough voltage headroom ( $\geq 2.5\text{V}$ ) and cathode current ( $I_{KA}$ ), ATL43x forces the reference pin to 2.5V. However, the reference pin can not be left floating, as it needs  $I_{\text{ref}} \geq 0.1\mu\text{A}$  (please see the [Functional Block Diagram](#)). This is because the reference pin is driven into an NPN, which needs base current in order operate properly.

When feedback is applied from the Cathode and Reference pins, ATL43x behaves as a Zener diode, regulating to a constant voltage dependent on current being supplied into the cathode. This is due to the internal amplifier and reference entering the proper operating regions. The same amount of current required in the above feedback situation must be applied to this device in open-loop, servo, or error amplifying implementations for the current to be in the proper linear region to give the ATL43x enough gain.

Unlike many linear regulators, ATL43x is internally compensated to be stable without an output capacitor between the cathode and anode; however, if it is desired to use an output capacitor, [Figure 5-14](#) through [Figure 5-21](#) can be used as a guide to assist in choosing the correct capacitor to maintain stability.

## 7.4 Device Functional Modes

### 7.4.1 Open Loop (Comparator)

When the cathode/output voltage or current of ATL43x is not being fed back to the reference/input pin in any form, this device is operating in open loop. With such high gain in this configuration, the ATL43x is typically used as a comparator. Due to the integrated reference, the ATL43x allows users to monitor a certain level of a single signal.

### 7.4.2 Closed Loop



When the cathode/output voltage or current of ATL43x is being fed back to the reference/input pin in any form, this device is operating in closed loop. The majority of applications involving the ATL43x use it in this manner to regulate a fixed voltage or current. The feedback enables this device to behave as an error amplifier, computing a portion of the output voltage and adjusting it to maintain the desired regulation. This is done by relating the output voltage back to the reference pin in a manner to make it equal to the internal reference voltage, which can be accomplished via resistive or direct feedback.

## 8 Application and Implementation

### 注

以下のアプリケーション情報は、TI の製品仕様に含まれるものではなく、TI ではその正確性または完全性を保証いたしません。個々の目的に対する製品の適合性については、お客様の責任で判断していただくこととなります。お客様は自身の設計実装を検証しテストすることで、システムの機能を確認する必要があります。

### 8.1 Application Information

 **8-1** shows the ATL43x used in a 24-V isolated flyback supply. The output of the regulator, plus the forward voltage drop of the optocoupler LED ( $2.5 + 0.7 = 3.2\text{V}$ ), determine the minimum voltage that can be regulated in an isolated supply configuration. Regulated voltage as low as 5.0Vdc is possible in the topology shown in  **8-1**.

The 431 family of devices are prevalent in these applications, being designers go-to choice for secondary side regulation. Due to this prevalence, this section will further go on to explain operation and design in both states of the ATL43x that this application sees: open-loop (Comparator +  $V_{ref}$ ) and closed-loop (Shunt Regulator).

The key benefit in isolated supplies for the ATL43x is the no load power savings gained by the  $> 20\times$  decrease in  $I_{Kmin}$  from TL431. More information about this and other benefits can be found in [Designing with the "Advanced" TL431, ATL431](#) (SLVA685). Further information about system stability and using a ATL43x device for compensation can be found in [Compensation Design With TL431 for UCC28600](#) (SLUA671).

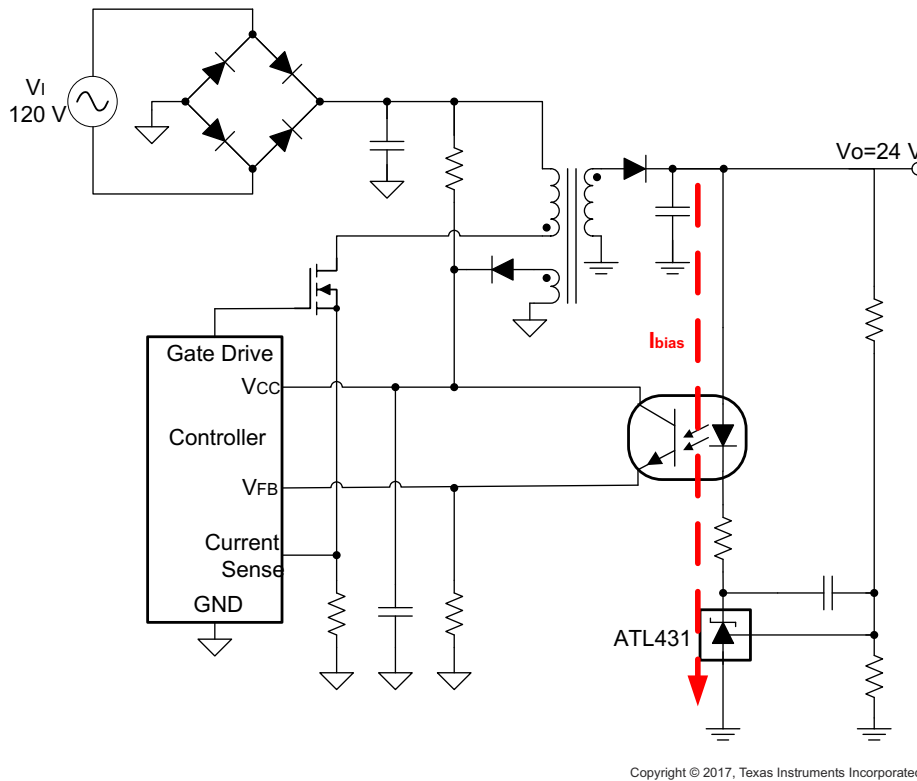

**図 8-1. Flyback With Isolation Using ATL43x as Voltage Reference and Error Amplifier**

It is important to consider the cathode voltage ramp rate when using ATL431 or ATL432 in overvoltage protection or other voltage monitoring applications, in optocoupler configurations, or any configuration where a power supply may ramp the cathode voltage quickly while ATL431 or ATL432 is meant to be in operation. For fast cathode current ramp rates, inaccurate responses may occur which can trip voltage monitoring circuits when an overvoltage or undervoltage condition has not actually been met. When designing with ATL431 or ATL432, it is

recommended that the ramp rate of the cathode voltage remain below  $0.0125\text{V}/\mu\text{s}$  to mitigate potential inaccuracies.

For voltage monitoring or other applications where a ramp rate faster than  $0.0125\text{ V}/\mu\text{s}$  is required, please consider other high-performance, pin-to-pin devices from TI: ATL431LI, TLA431, or TL431.

## 8.2 Typical Applications

### 8.2.1 Comparator With Integrated Reference (Open-Loop)

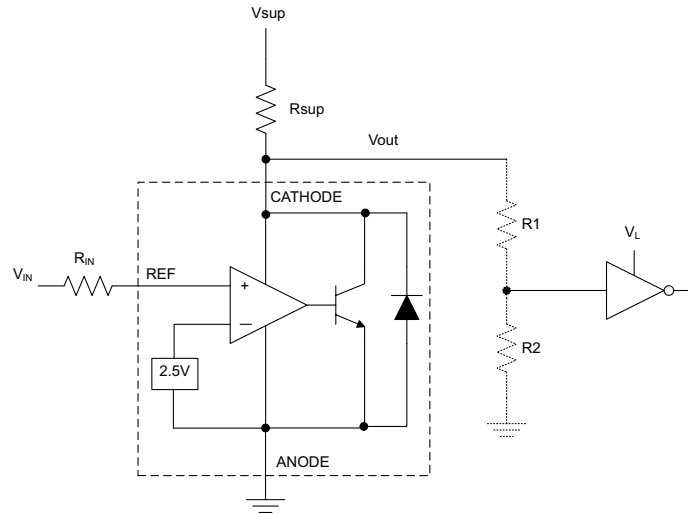

Copyright © 2017, Texas Instruments Incorporated

**図 8-2. Comparator Application Schematic**

#### 8.2.1.1 Design Requirements

For this design example, use the parameters listed in [表 8-1](#) as the input parameters.

**表 8-1. Design Parameters**

DESIGN PARAMETER	EXAMPLE VALUE
Input voltage range	0V to 3.3V
Input resistance	100kΩ
Supply voltage	5V
Cathode current ( $I_K$ )	50μA
High output voltage level ( $V_{in} < 2.5\text{V}$ )	$V_{sup}$
Low output voltage ( $V_{in} > 2.5\text{V}$ )	~2V

#### 8.2.1.2 Detailed Design Procedure

When using the ATL43x as a comparator with reference, determine the following:

- Input voltage range
- Reference voltage accuracy
- Output logic input high and low level thresholds
- Current source resistance

##### 8.2.1.2.1 Basic Operation

In the configuration shown in [図 8-2](#), the ATL43x behaves as a comparator, comparing the  $V_{ref}$  pin voltage to the internal virtual reference voltage. When provided a proper cathode current ( $I_K$ ), ATL43x have enough open-loop

gain to provide a quick response. With the maximum operating current ( $I_{\min}$ ) of ATL43x being  $35\mu\text{A}$ , operation below that can result in low gain; leading to a slow response.

#### 8.2.1.2.2 Overdrive

Slow or inaccurate responses can also occur when the reference pin is not provided enough overdrive voltage. This is the amount of voltage that is higher than the internal virtual reference. The internal virtual reference voltage will be within the range of  $2.5\text{V} \pm (0.5\% \text{ or } 1.0\%)$  depending on which version is being used.

The more overdrive voltage provided, the faster the ATL43x responds.

For applications where ATL43x is being used as a comparator, it is best to set the trip point to greater than the positive expected error (that is, +1.0% for the A version). For fast response, setting the trip point to  $> 10\%$  of the internal  $V_{\text{ref}}$  should suffice. [Figure 8-3](#) shows the transition from  $V_{\text{OH}}$  to  $V_{\text{OL}}$  based on the input voltage and can be used as a guide for selecting the overdrive voltage.

For minimal voltage drop or difference from  $V_{\text{in}}$  to the ref pin, TI recommends using an input resistor  $< 1\text{M}\Omega$  to provide  $I_{\text{ref}}$ .

#### 8.2.1.2.3 Output Voltage and Logic Input Level

In order for ATL43x to properly be used as a comparator, the logic output must be readable by the receiving logic device. This is accomplished by knowing the input high and low level threshold voltage levels, typically denoted by  $V_{\text{IH}}$  and  $V_{\text{IL}}$ .

As seen in [Figure 8-3](#), the output low level voltage for ATL43x in open-loop/comparator mode is  $\sim 2\text{V}$ , which is sufficient for some  $\geq 5\text{-V}$  supplied logic. However, would not work for  $3.3\text{-V}$  and  $1.8\text{-V}$  supplied logic. To accommodate this, a resistive divider can be tied to the output to attenuate the output voltage to a voltage legible to the receiving low voltage logic device.

The output high voltage for ATL43x is approximately  $V_{\text{sup}}$  due to ATL43x being open-collector. If  $V_{\text{sup}}$  is much higher than the receiving maximum input voltage tolerance of the logic, the output must be attenuated to accommodate the reliability of the outgoing logic.

When using a resistive divider on the output, ensure that the sum of the resistive divider ( $R_1$  and  $R_2$  in [Figure 8-2](#)) is much greater than  $R_{\text{sup}}$  so that the resistive divider does not interfere with the ability of the ATL43x to pull close to  $V_{\text{sup}}$  when turning off.

##### 8.2.1.2.3.1 Input Resistance

ATL43x requires an input resistance in this application in order to source the reference current ( $I_{\text{ref}}$ ) needed from this device to be in the proper operating regions while turning on. The actual voltage seen at the ref pin will be:

$$V_{\text{ref}} = V_{\text{in}} - I_{\text{ref}} \times R_{\text{in}} \quad (1)$$

Because  $I_{\text{ref}}$  can be as high as  $0.15\mu\text{A}$ , TI recommends using a resistance small enough that will mitigate the error that  $I_{\text{ref}}$  creates from  $V_{\text{in}}$ . Also, the input resistance must be set high enough as to not surpass the absolute maximum of  $10\text{mA}$ .

8.2.1.3 Application Curve

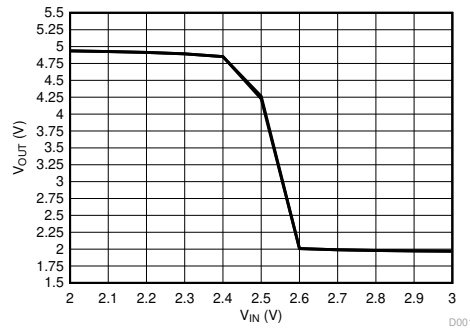

$R_{IN} = 100k\Omega$        $V_{SUP} = 5.0V$        $R_{SUP} = 10k\Omega$

図 8-3. Open-Loop (Comparator Mode)  $V_{OUT}$  vs  $V_{IN}$

8.2.2 Shunt Regulator/Reference

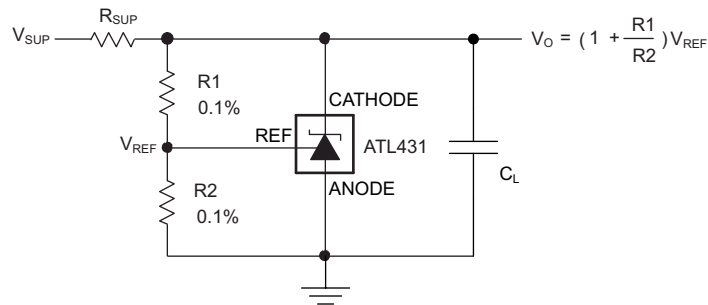

Copyright © 2017, Texas Instruments Incorporated

図 8-4. Shunt Regulator Schematic

8.2.2.1 Design Requirements

For this design example, use the parameters listed in 表 8-2 as the input parameters.

表 8-2. Design Parameters

DESIGN PARAMETER	EXAMPLE VALUE
Reference initial accuracy	1.0%
Supply voltage	48V
Cathode current ( $I_k$ )	50 $\mu$ A
Output voltage level	2.5V to 36V
Load capacitance	1nF
Feedback resistor values (R1 and R2)	10k $\Omega$

8.2.2.2 Detailed Design Procedure

When using the ATL43x as a Shunt Regulator, determine the following:

- Input voltage range
- Temperature range
- Total accuracy
- Cathode current
- Reference initial accuracy
- Output capacitance

### 8.2.2.2.1 Programming Output/Cathode Voltage

To program the cathode voltage to a regulated voltage a resistive bridge must be shunted between the cathode and anode pins with the mid point tied to the reference pin. This can be seen in [Figure 8-4](#), with R1 and R2 being the resistive bridge. The cathode/output voltage in the shunt regulator configuration can be approximated by the equation shown in [Equation 8-4](#). The cathode voltage can be more accurately determined by taking in to account the cathode current:

$$V_O = (1 + R1 / R2) \times V_{ref} - I_{ref} \times R1 \quad (2)$$

For this equation to be valid, the ATL43x must be fully biased so that it has enough open-loop gain to mitigate any gain error. This can be done by meeting the  $I_{min}$  spec denoted in [Electrical Characteristics, ATL431Ax, ATL432Ax](#) table.

### 8.2.2.2.2 Total Accuracy

When programming the output above unity gain ( $V_{KA} = V_{ref}$ ), ATL43x is susceptible to other errors that may effect the overall accuracy beyond  $V_{ref}$ . These errors include:

- R1 and R2 accuracies
- $V_{I(dev)}$  – Change in reference voltage over temperature
- $\Delta V_{ref} / \Delta V_{KA}$  – Change in reference voltage to the change in cathode voltage
- $|z_{KA}|$  – Dynamic impedance, causing a change in cathode voltage with cathode current

Worst case cathode voltage can be determined taking all of the variables in to account. [Setting the Shunt Voltage on an Adjustable Shunt](#) (SLVA445), assists designers in setting the shunt voltage to achieve optimum accuracy for this device.

### 8.2.2.2.3 Stability

Though the ATL43x is stable with no capacitive load, the device that receives the output voltage of the shunt regulator could present a capacitive load that is within the ATL43x region of stability, shown in [Figure 5-14](#) through [Figure 5-21](#). Also, designers can use capacitive loads to improve the transient response or for power supply decoupling.

[Figure 5-14](#) through [Figure 5-21](#) should be used as a guide for capacitor selection and compensation. It is characterized using ceramic capacitors with very-low ESR. When it is desirable to use a capacitor within the unstable region, higher ESR capacitors can be used to stabilize ATL43x or an external series resistance can be added. For more information and guidance on ESR values, see [Designing with the "Advanced" TL431, ATL431](#) (SLVA685).

Unlike the TL431, the stability boundary is characterized and determined with resistors 250 $\Omega$  and greater. Which is designed for low cathode current applications.

### 8.2.2.3 Application Curves

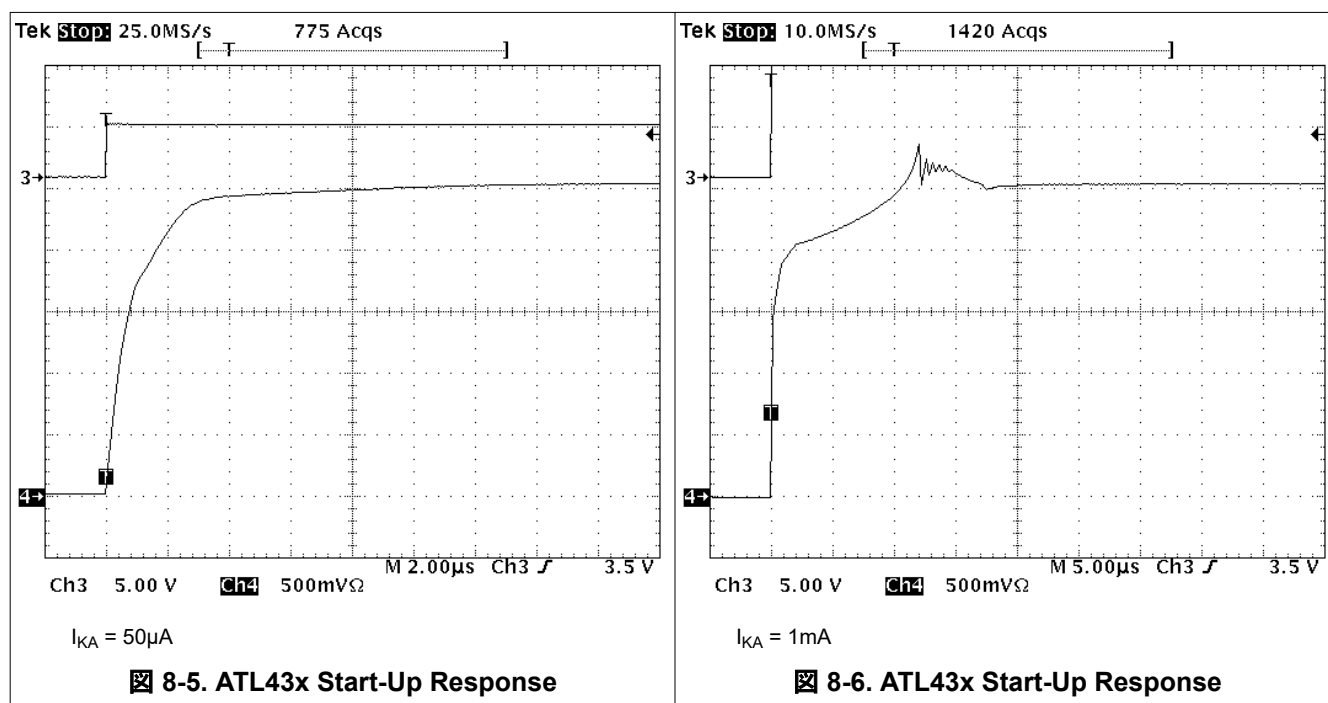

## 9 Power Supply Recommendations

When using the ATL43x in a flyback supply (see [Figure 8-1](#)), it is often common for designers to place the bias resistor between the Anode of the Opto-Coupler and the output voltage ( $V_O = 24V$ ). However, this makes the ATL43x more susceptible to EOS/ESD damage. Therefore, TI recommends placing the bias resistor between the Cathodes of the Opto-Coupler and the ATL43x, as shown in [Figure 8-1](#). For further explanation, see [Designing with the "Advanced" TL431, ATL431](#) (SLVA685).

When using the ATL43x as a Linear Regulator to supply a load, designers will typically use a bypass capacitor on the output/cathode pin. Be sure that the capacitance is within the stability criteria shown in [Figure 5-14](#) through [Figure 5-21](#).

To not exceed the maximum cathode current, be sure that the supply voltage is current limited. Also, be sure to limit the current being driven into the Ref pin, as not to exceed the absolute maximum rating.

For applications shunting high currents, pay attention to the cathode and anode trace lengths, adjusting the width of the traces to have the proper current density.

## 10 Layout

### 10.1 Layout Guidelines

Place decoupling capacitors as close to the device as possible. Use appropriate widths for traces when shunting high currents to avoid excessive voltage drops.

### 10.2 Layout Example

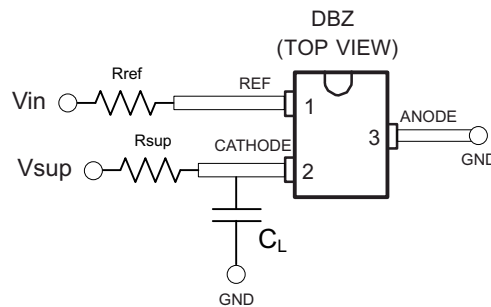

**Figure 10-1. DBZ Layout Example**

## 11 Device and Documentation Support

### 11.1 ドキュメントの更新通知を受け取る方法

ドキュメントの更新についての通知を受け取るには、[www.tij.co.jp](http://www.tij.co.jp) のデバイス製品フォルダを開いてください。[通知] をクリックして登録すると、変更されたすべての製品情報に関するダイジェストを毎週受け取ることができます。変更の詳細については、改訂されたドキュメントに含まれている改訂履歴をご覧ください。

### 11.2 サポート・リソース

テキサス・インスツルメンツ E2E™ サポート・フォーラムは、エンジニアが検証済みの回答と設計に関するヒントをエキスパートから迅速かつ直接得ることができる場所です。既存の回答を検索したり、独自の質問をしたりすることで、設計に必要な支援を迅速に得ることができます。

リンクされているコンテンツは、各寄稿者により「現状のまま」提供されるものです。これらはテキサス・インスツルメンツの仕様を構成するものではなく、必ずしもテキサス・インスツルメンツの見解を反映したものではありません。テキサス・インスツルメンツの[使用条件](#)を参照してください。

### 11.3 Trademarks

テキサス・インスツルメンツ E2E™ is a trademark of Texas Instruments.

すべての商標は、それぞれの所有者に帰属します。

### 11.4 静電気放電に関する注意事項



この IC は、ESD によって破損する可能性があります。テキサス・インスツルメンツは、IC を取り扱う際には常に適切な注意を払うことを推奨します。正しい取り扱いおよび設置手順に従わない場合、デバイスを破損するおそれがあります。

ESD による破損は、わずかな性能低下からデバイスの完全な故障まで多岐にわたります。精密な IC の場合、パラメータがわずかに変化するだけで公表されている仕様から外れる可能性があるため、破損が発生しやすくなっています。

### 11.5 用語集

[テキサス・インスツルメンツ用語集](#) この用語集には、用語や略語の一覧および定義が記載されています。

## 12 Revision History

資料番号末尾の英字は改訂を表しています。その改訂履歴は英語版に準じています。

<b>Changes from Revision D (October 2016) to Revision E (December 2024)</b>	<b>Page</b>
• ドキュメント全体にわたって表、図、相互参照の採番方法を更新.....	1
• Updated Application Information .....	15
<hr/>	
<b>Changes from Revision C (September 2015) to Revision D (October 2016)</b>	<b>Page</b>
• Changed <i>Small-Signal Voltage Amplification vs Frequency</i> with an updated graph to provide additional data.....	6
• Changed <i>Test Circuit for Phase and Gain Measurement</i> with an updated schematic.....	11
• Updated Comparator Mode specifications in <i>Design Parameters</i> .....	16
• Added <i>Receiving Notification of Documentation Updates</i> section.....	22
<hr/>	
<b>Changes from Revision B (May 2015) to Revision C (September 2015)</b>	<b>Page</b>
• ATL432xx のステータスをプレビューから量産に変更.....	1
<hr/>	
<b>Changes from Revision A (April 2015) to Revision B (May 2015)</b>	<b>Page</b>
• ATL431AQ、ATL431BI、および ATL431BQ のステータスをプレビューから量産に変更.....	1
• Changed flyback schematic to represent a more robust design .....	15
• Added flyback supply reliability recommendation.....	21
<hr/>	
<b>Changes from Revision * (March 2013) to Revision A (April 2015)</b>	<b>Page</b>
• 完全版の初回リリース。.....	1

## 13 Mechanical, Packaging, and Orderable Information

The following pages include mechanical, packaging, and orderable information. This information is the most current data available for the designated devices. This data is subject to change without notice and revision of this document. For browser-based versions of this data sheet, refer to the left-hand navigation.

**PACKAGING INFORMATION**

Orderable part number	Status (1)	Material type (2)	Package   Pins	Package qty   Carrier	RoHS (3)	Lead finish/ Ball material (4)	MSL rating/ Peak reflow (5)	Op temp (°C)	Part marking (6)
<a href="#">ATL431AIDBZR</a>	Active	Production	SOT-23 (DBZ)   3	3000   LARGE T&R	Yes	NIPDAU   NIPDAUAG	Level-1-260C-UNLIM	-40 to 85	(ZCKS, ZCR3)
ATL431AIDBZR.A	Active	Production	SOT-23 (DBZ)   3	3000   LARGE T&R	Yes	NIPDAU	Level-1-260C-UNLIM	-40 to 85	(ZCKS, ZCR3)
<a href="#">ATL431AQDBZR</a>	Active	Production	SOT-23 (DBZ)   3	3000   LARGE T&R	Yes	NIPDAU   NIPDAUAG	Level-1-260C-UNLIM	-40 to 125	(ZCLS, ZCS3)
ATL431AQDBZR.A	Active	Production	SOT-23 (DBZ)   3	3000   LARGE T&R	Yes	NIPDAU	Level-1-260C-UNLIM	-40 to 125	(ZCLS, ZCS3)
<a href="#">ATL431BIDBZR</a>	Active	Production	SOT-23 (DBZ)   3	3000   LARGE T&R	Yes	NIPDAU   NIPDAUAG	Level-1-260C-UNLIM	-40 to 85	(ZCMS, ZCT3)
ATL431BIDBZR.A	Active	Production	SOT-23 (DBZ)   3	3000   LARGE T&R	Yes	NIPDAU	Level-1-260C-UNLIM	-40 to 85	(ZCMS, ZCT3)
<a href="#">ATL431BQDBZR</a>	Active	Production	SOT-23 (DBZ)   3	3000   LARGE T&R	Yes	NIPDAU   NIPDAUAG	Level-1-260C-UNLIM	-40 to 125	(ZCJS, ZCU3)
ATL431BQDBZR.A	Active	Production	SOT-23 (DBZ)   3	3000   LARGE T&R	Yes	NIPDAU	Level-1-260C-UNLIM	-40 to 125	(ZCJS, ZCU3)
<a href="#">ATL432AIDBZR</a>	Active	Production	SOT-23 (DBZ)   3	3000   LARGE T&R	Yes	NIPDAU   NIPDAUAG	Level-1-260C-UNLIM	-40 to 85	(ZCNS, ZCV3)
ATL432AIDBZR.A	Active	Production	SOT-23 (DBZ)   3	3000   LARGE T&R	Yes	NIPDAU	Level-1-260C-UNLIM	-40 to 85	(ZCNS, ZCV3)
<a href="#">ATL432AQDBZR</a>	Active	Production	SOT-23 (DBZ)   3	3000   LARGE T&R	Yes	NIPDAU   NIPDAUAG	Level-1-260C-UNLIM	-40 to 125	(ZCOS, ZCW3)
ATL432AQDBZR.A	Active	Production	SOT-23 (DBZ)   3	3000   LARGE T&R	Yes	NIPDAU	Level-1-260C-UNLIM	-40 to 125	(ZCOS, ZCW3)
<a href="#">ATL432BIDBZR</a>	Active	Production	SOT-23 (DBZ)   3	3000   LARGE T&R	Yes	NIPDAU   NIPDAUAG	Level-1-260C-UNLIM	-40 to 85	(ZCPS, ZCX3)
ATL432BIDBZR.A	Active	Production	SOT-23 (DBZ)   3	3000   LARGE T&R	Yes	NIPDAU	Level-1-260C-UNLIM	-40 to 85	(ZCPS, ZCX3)
<a href="#">ATL432BQDBZR</a>	Active	Production	SOT-23 (DBZ)   3	3000   LARGE T&R	Yes	NIPDAU   NIPDAUAG	Level-1-260C-UNLIM	-40 to 125	(ZCQS, ZCY3)
ATL432BQDBZR.A	Active	Production	SOT-23 (DBZ)   3	3000   LARGE T&R	Yes	NIPDAU	Level-1-260C-UNLIM	-40 to 125	(ZCQS, ZCY3)

(1) **Status:** For more details on status, see our [product life cycle](#).

(2) **Material type:** When designated, preproduction parts are prototypes/experimental devices, and are not yet approved or released for full production. Testing and final process, including without limitation quality assurance, reliability performance testing, and/or process qualification, may not yet be complete, and this item is subject to further changes or possible discontinuation. If available for ordering, purchases will be subject to an additional waiver at checkout, and are intended for early internal evaluation purposes only. These items are sold without warranties of any kind.

(3) **RoHS values:** Yes, No, RoHS Exempt. See the [TI RoHS Statement](#) for additional information and value definition.

(4) **Lead finish/Ball material:** Parts may have multiple material finish options. Finish options are separated by a vertical ruled line. Lead finish/Ball material values may wrap to two lines if the finish value exceeds the maximum column width.

(5) **MSL rating/Peak reflow:** The moisture sensitivity level ratings and peak solder (reflow) temperatures. In the event that a part has multiple moisture sensitivity ratings, only the lowest level per JEDEC standards is shown. Refer to the shipping label for the actual reflow temperature that will be used to mount the part to the printed circuit board.

**(6) Part marking:** There may be an additional marking, which relates to the logo, the lot trace code information, or the environmental category of the part.

Multiple part markings will be inside parentheses. Only one part marking contained in parentheses and separated by a "-" will appear on a part. If a line is indented then it is a continuation of the previous line and the two combined represent the entire part marking for that device.

**Important Information and Disclaimer:**The information provided on this page represents TI's knowledge and belief as of the date that it is provided. TI bases its knowledge and belief on information provided by third parties, and makes no representation or warranty as to the accuracy of such information. Efforts are underway to better integrate information from third parties. TI has taken and continues to take reasonable steps to provide representative and accurate information but may not have conducted destructive testing or chemical analysis on incoming materials and chemicals. TI and TI suppliers consider certain information to be proprietary, and thus CAS numbers and other limited information may not be available for release.

In no event shall TI's liability arising out of such information exceed the total purchase price of the TI part(s) at issue in this document sold by TI to Customer on an annual basis.

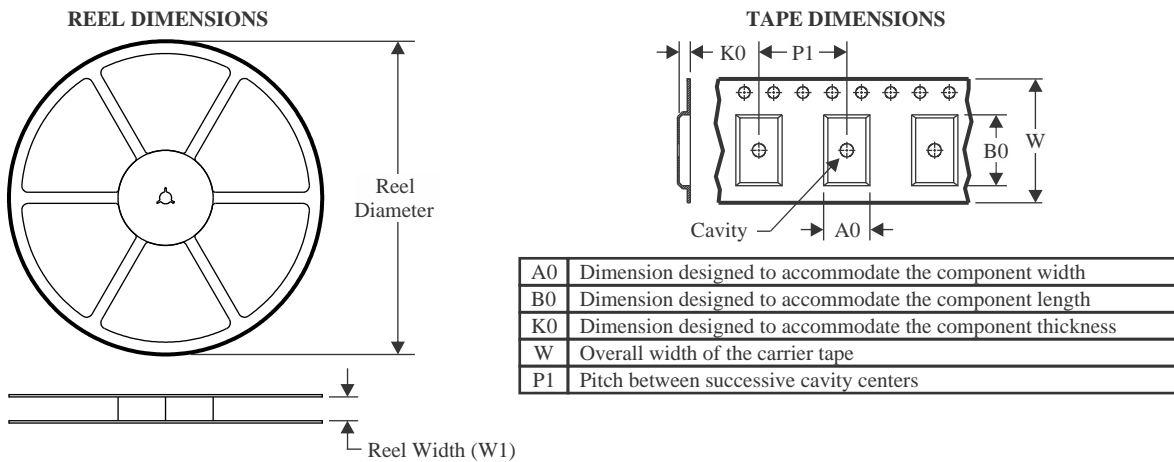
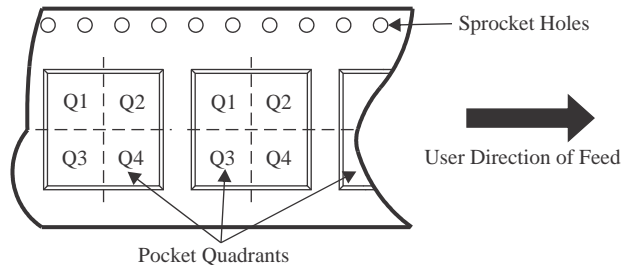
**TAPE AND REEL INFORMATION**

**QUADRANT ASSIGNMENTS FOR PIN 1 ORIENTATION IN TAPE**

\*All dimensions are nominal

Device	Package Type	Package Drawing	Pins	SPQ	Reel Diameter (mm)	Reel Width W1 (mm)	A0 (mm)	B0 (mm)	K0 (mm)	P1 (mm)	W (mm)	Pin1 Quadrant
ATL431AIDBZR	SOT-23	DBZ	3	3000	180.0	8.4	2.9	3.35	1.35	4.0	8.0	Q3
ATL431AIDBZR	SOT-23	DBZ	3	3000	178.0	9.2	3.15	2.77	1.22	4.0	8.0	Q3
ATL431AQDBZR	SOT-23	DBZ	3	3000	180.0	8.4	2.9	3.35	1.35	4.0	8.0	Q3
ATL431AQDBZR	SOT-23	DBZ	3	3000	178.0	9.2	3.15	2.77	1.22	4.0	8.0	Q3
ATL431AQDBZR	SOT-23	DBZ	3	3000	180.0	8.4	3.15	2.77	1.22	4.0	8.0	Q3
ATL431BIDBZR	SOT-23	DBZ	3	3000	180.0	8.4	3.15	2.77	1.22	4.0	8.0	Q3
ATL431BIDBZR	SOT-23	DBZ	3	3000	178.0	9.2	3.15	2.77	1.22	4.0	8.0	Q3
ATL431BIDBZR	SOT-23	DBZ	3	3000	180.0	8.4	2.9	3.35	1.35	4.0	8.0	Q3
ATL431BQDBZR	SOT-23	DBZ	3	3000	180.0	8.4	2.9	3.35	1.35	4.0	8.0	Q3
ATL431BQDBZR	SOT-23	DBZ	3	3000	178.0	9.2	3.15	2.77	1.22	4.0	8.0	Q3
ATL432AIDBZR	SOT-23	DBZ	3	3000	178.0	9.2	3.15	2.77	1.22	4.0	8.0	Q3
ATL432AIDBZR	SOT-23	DBZ	3	3000	180.0	8.4	2.9	3.35	1.35	4.0	8.0	Q3
ATL432AQDBZR	SOT-23	DBZ	3	3000	180.0	8.4	2.9	3.35	1.35	4.0	8.0	Q3
ATL432AQDBZR	SOT-23	DBZ	3	3000	180.0	8.4	3.15	2.77	1.22	4.0	8.0	Q3
ATL432AQDBZR	SOT-23	DBZ	3	3000	178.0	9.2	3.15	2.77	1.22	4.0	8.0	Q3
ATL432BIDBZR	SOT-23	DBZ	3	3000	180.0	8.4	2.9	3.35	1.35	4.0	8.0	Q3

Device	Package Type	Package Drawing	Pins	SPQ	Reel Diameter (mm)	Reel Width W1 (mm)	A0 (mm)	B0 (mm)	K0 (mm)	P1 (mm)	W (mm)	Pin1 Quadrant
ATL432BIDBZR	SOT-23	DBZ	3	3000	178.0	9.2	3.15	2.77	1.22	4.0	8.0	Q3
ATL432BQDBZR	SOT-23	DBZ	3	3000	178.0	9.2	3.15	2.77	1.22	4.0	8.0	Q3
ATL432BQDBZR	SOT-23	DBZ	3	3000	180.0	8.4	2.9	3.35	1.35	4.0	8.0	Q3

**TAPE AND REEL BOX DIMENSIONS**

\*All dimensions are nominal

Device	Package Type	Package Drawing	Pins	SPQ	Length (mm)	Width (mm)	Height (mm)
ATL431AIDBZR	SOT-23	DBZ	3	3000	210.0	185.0	35.0
ATL431AIDBZR	SOT-23	DBZ	3	3000	180.0	180.0	18.0
ATL431AQDBZR	SOT-23	DBZ	3	3000	210.0	185.0	35.0
ATL431AQDBZR	SOT-23	DBZ	3	3000	180.0	180.0	18.0
ATL431AQDBZR	SOT-23	DBZ	3	3000	183.0	183.0	20.0
ATL431BIDBZR	SOT-23	DBZ	3	3000	183.0	183.0	20.0
ATL431BIDBZR	SOT-23	DBZ	3	3000	180.0	180.0	18.0
ATL431BIDBZR	SOT-23	DBZ	3	3000	210.0	185.0	35.0
ATL431BQDBZR	SOT-23	DBZ	3	3000	210.0	185.0	35.0
ATL431BQDBZR	SOT-23	DBZ	3	3000	180.0	180.0	18.0
ATL432AIDBZR	SOT-23	DBZ	3	3000	180.0	180.0	18.0
ATL432AIDBZR	SOT-23	DBZ	3	3000	210.0	185.0	35.0
ATL432AQDBZR	SOT-23	DBZ	3	3000	210.0	185.0	35.0
ATL432AQDBZR	SOT-23	DBZ	3	3000	183.0	183.0	20.0
ATL432AQDBZR	SOT-23	DBZ	3	3000	180.0	180.0	18.0
ATL432BIDBZR	SOT-23	DBZ	3	3000	210.0	185.0	35.0
ATL432BIDBZR	SOT-23	DBZ	3	3000	180.0	180.0	18.0
ATL432BQDBZR	SOT-23	DBZ	3	3000	180.0	180.0	18.0

---

Device	Package Type	Package Drawing	Pins	SPQ	Length (mm)	Width (mm)	Height (mm)
ATL432BQDBZR	SOT-23	DBZ	3	3000	210.0	185.0	35.0



# EXAMPLE BOARD LAYOUT

DBZ0003A

SOT-23 - 1.12 mm max height

SMALL OUTLINE TRANSISTOR

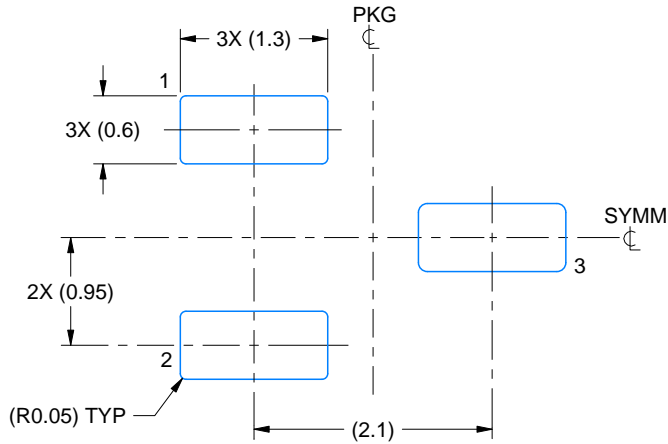

LAND PATTERN EXAMPLE  
SCALE:15X

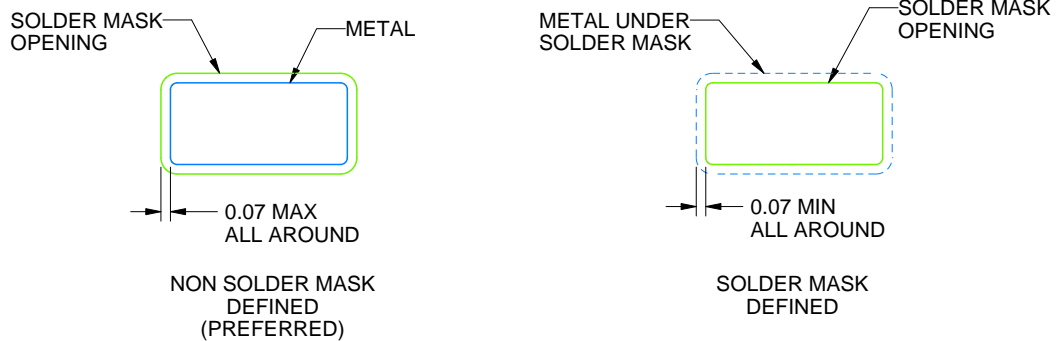

SOLDER MASK DETAILS

4214838/F 08/2024

NOTES: (continued)

- 5. Publication IPC-7351 may have alternate designs.
- 6. Solder mask tolerances between and around signal pads can vary based on board fabrication site.

# EXAMPLE STENCIL DESIGN

DBZ0003A

SOT-23 - 1.12 mm max height

SMALL OUTLINE TRANSISTOR

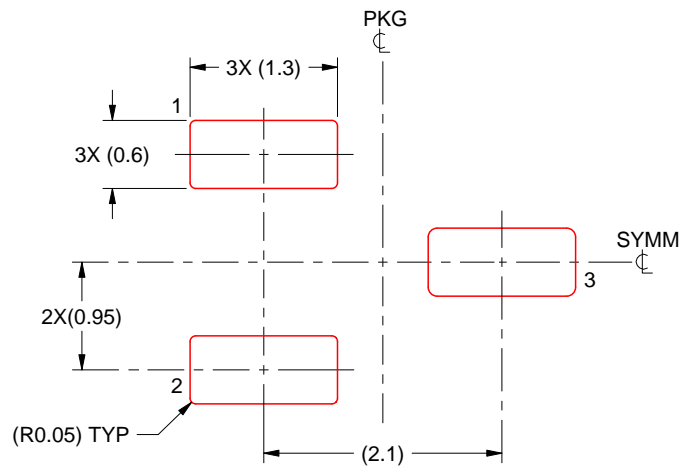

SOLDER PASTE EXAMPLE  
BASED ON 0.125 THICK STENCIL  
SCALE:15X

4214838/F 08/2024

NOTES: (continued)

7. Laser cutting apertures with trapezoidal walls and rounded corners may offer better paste release. IPC-7525 may have alternate design recommendations.
8. Board assembly site may have different recommendations for stencil design.

## 重要なお知らせと免責事項

TI は、技術データと信頼性データ (データシートを含みます)、設計リソース (リファレンス デザインを含みます)、アプリケーションや設計に関する各種アドバイス、Web ツール、安全性情報、その他のリソースを、欠陥が存在する可能性のある「現状のまま」提供しており、商品性および特定目的に対する適合性の黙示保証、第三者の知的財産権の非侵害保証を含むいかなる保証も、明示的または黙示的にかかわらず拒否します。

これらのリソースは、TI 製品を使用する設計の経験を積んだ開発者への提供を意図したものです。(1) お客様のアプリケーションに適した TI 製品の選定、(2) お客様のアプリケーションの設計、検証、試験、(3) お客様のアプリケーションに該当する各種規格や、その他のあらゆる安全性、セキュリティ、規制、または他の要件への確実な適合に関する責任を、お客様のみが単独で負うものとし、

上記の各種リソースは、予告なく変更される可能性があります。これらのリソースは、リソースで説明されている TI 製品を使用するアプリケーションの開発の目的でのみ、TI はその使用をお客様に許諾します。これらのリソースに関して、他の目的で複製することや掲載することは禁止されています。TI や第三者の知的財産権のライセンスが付与されている訳ではありません。お客様は、これらのリソースを自身で使用した結果発生するあらゆる申し立て、損害、費用、損失、責任について、TI およびその代理人を完全に補償するものとし、TI は一切の責任を拒否します。

TI の製品は、[TI の販売条件](#)、[TI の総合的な品質ガイドライン](#)、[ti.com](#) または TI 製品などに関連して提供される他の適用条件に従い提供されます。TI がこれらのリソースを提供することは、適用される TI の保証または他の保証の放棄の拡大や変更を意味するものではありません。TI がカスタム、またはカスタマー仕様として明示的に指定していない限り、TI の製品は標準的なカタログに掲載される汎用機器です。

お客様がいかなる追加条項または代替条項を提案する場合も、TI はそれらに異議を唱え、拒否します。

Copyright © 2026, Texas Instruments Incorporated

最終更新日 : 2025 年 10 月