

INA260 高精度デジタル電流および電力モニタ、 低ドリフト係数、高精度シャント内蔵

1 特長

- 高精度のシャント抵抗を内蔵:
 - 電流センス抵抗: 2mΩ
 - 許容範囲は0.1%に等価
 - -40°C~+85°Cで15Aの連続電流
 - 温度ドリフト係数10ppm/°C (0°C~+125°C)
- 0V~36Vのバス電圧を検出
- ハイサイドまたはローサイドのセンシング
- 電流、電圧、電力を報告
- 高精度:
 - システム・ゲイン誤差0.15% (最大値)
 - オフセット5mA (最大値)
- 平均化オプションを設定可能
- 16のアドレスをプログラム可能
- 2.7V~5.5V電源で動作
- 16ピンのTSSOPパッケージ

2 アプリケーション

- 試験用機器
- サーバー
- 通信機器
- コンピューティング
- パワー・マネージメント
- バッテリ充電器
- 電源

3 概要

INA260はデジタル出力の電流、電力、電圧モニタで、 I^2C および SMBus™ 互換のインターフェイスが搭載され、高精度のシャント抵抗が内蔵されています。電源電圧にかかわらず、0V~36Vの同相電圧で、高精度の電流および電力測定、および過電流検出が可能です。このデバイスは双方向、ローサイドまたはハイサイドの電流シャント・モニタで、内部の電流センシング抵抗を通過する電流を測定します。高精度の電流センシング抵抗が内蔵されているため、校正と等価の測定精度があり、温度ドリフト係数が非常に低く、センシング抵抗について最適化されたケルビン・レイアウトが常に得られることが保証されます。

INA260では、 I^2C 互換インターフェイス上で16までのアドレスをプログラム可能です。デジタル・インターフェイスにより、アラートのスレッシュホールド、アナログ/デジタル・コンバータ(ADC)の変換時間、平均化をプログラムできます。さらに使いやすくするため、内部のマルチプライヤにより電流をアンペア単位、電力をワット単位で直接読み出しできます。

このデバイスは単一の2.7V~5.5V電源で動作し、310μAの電流を消費します。INA260は-40°C~+125°Cの動作時温度範囲で動作が規定されており、16ピンのTSSOPパッケージで供給されます。

製品情報⁽¹⁾

型番	パッケージ	本体サイズ(公称)
INA260	TSSOP (16)	5.00mmx4.40mm

(1) 提供されているすべてのパッケージについては、巻末の注文情報を参照してください。

ハイサイド・センシング・アプリケーション

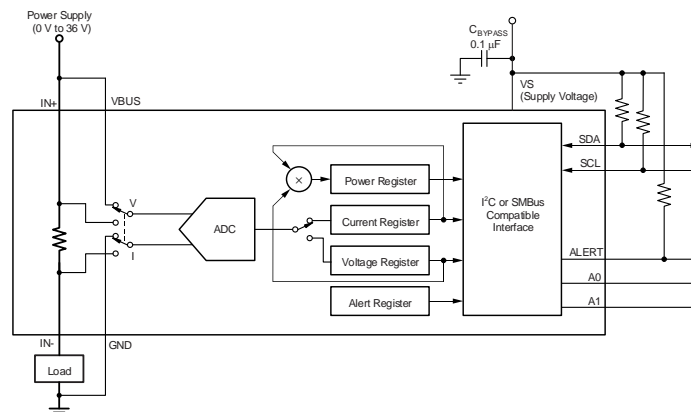

目次

1	特長	1	8.5	Programming	17
2	アプリケーション	1	8.6	Register Maps	21
3	概要	1	9	Application and Implementation	27
4	改訂履歴	2	9.1	Application Information	27
5	Related Products	3	9.2	Typical Application	27
6	Pin Configuration and Functions	4	10	Power Supply Recommendations	29
7	Specifications	5	11	Layout	29
7.1	Absolute Maximum Ratings	5	11.1	Layout Guidelines	29
7.2	ESD Ratings	5	11.2	Layout Example	29
7.3	Recommended Operating Conditions	5	12	デバイスおよびドキュメントのサポート	30
7.4	Thermal Information	5	12.1	デバイス・サポート	30
7.5	Electrical Characteristics	6	12.2	ドキュメントのサポート	30
7.6	Typical Characteristics	8	12.3	ドキュメントの更新通知を受け取る方法	30
8	Detailed Description	12	12.4	コミュニティ・リソース	30
8.1	Overview	12	12.5	商標	30
8.2	Functional Block Diagram	12	12.6	静電気放電に関する注意事項	30
8.3	Feature Description	12	12.7	用語集	30
8.4	Device Functional Modes	16	13	メカニカル、パッケージ、および注文情報	30

4 改訂履歴

資料番号末尾の英字は改訂を表しています。その改訂履歴は英語版に準じています。

Revision B (December 2016) から Revision C に変更	Page
• 変更 parameter symbol for current sense offset from: V_{OS} to: I_{OS} in <i>Electrical Characteristics</i> table	8

Revision A (August 2016) から Revision B に変更	Page
• デバイスの状態を量産データへ 変更	1

5 Related Products

DEVICE	DESCRIPTION
INA250	36-V, Low- or High-Side, Bidirectional, Zero-Drift Current-Shunt Monitor with Precision Integrated Shunt Resistor
INA226	High-Side or Low-Side Measurement, Bi-Directional Current and Power Monitor with I ² C Compatible Interface
INA230	High- or Low-Side Measurement, Bidirectional Current/Power Monitor with I ² C Interface
INA210 , INA211 , INA212 , INA213 , INA214 , INA215	Voltage Output, Low- or High-Side Measurement, Bidirectional, Zero-Drift Series, Current-Shunt Monitors

6 Pin Configuration and Functions

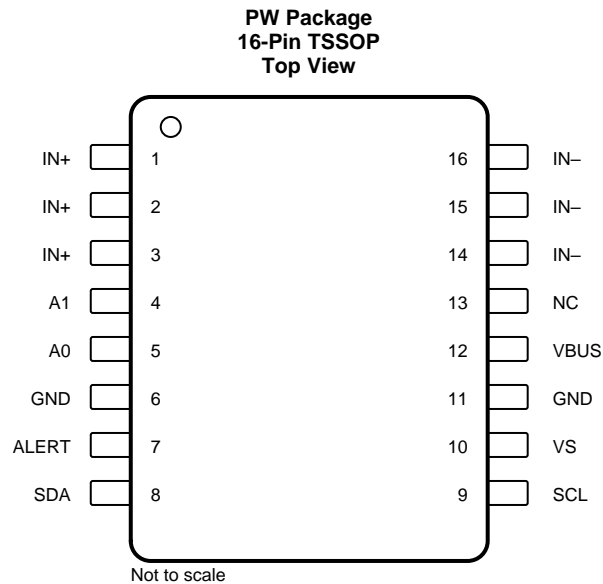

Pin Functions

PIN		I/O	DESCRIPTION
NAME	NO.		
A0	5	Digital input	Address pin. Connect to GND, SCL, SDA, or VS. 表 2 shows pin settings and corresponding addresses.
A1	4	Digital input	Address pin. Connect to GND, SCL, SDA, or VS. 表 2 shows pin settings and corresponding addresses.
ALERT	7	Digital output	Multi-functional alert, open-drain output.
GND	6, 11	Analog	Ground pin for both analog and digital circuits.
IN+	1, 2, 3	Analog input	Connect to supply for high side current sensing or to load ground for low side sensing.
IN–	14, 15, 16	Analog input	Connect to load for high side current sensing or to board ground for low side sensing.
NC	13	—	No internal connection. Can be grounded or left floating.
SCL	9	Digital input	Serial bus clock line input.
SDA	8	Digital I/O	Serial bus data line, open-drain input/output.
VBUS	12	Analog input	Bus voltage monitor input.
VS	10	Analog	Power supply input, connect a 2.7 V to 5.5 V supply to this pin.

7 Specifications

7.1 Absolute Maximum Ratings

over operating free-air temperature range (unless otherwise noted)⁽¹⁾

		MIN	MAX	UNIT
Analog input current	Continuous Conduction		±15	A
Analog inputs: IN+, IN–	Common-mode ($V_{IN+} + V_{IN-}$) / 2	–0.3	40	V
Voltage	Supply, VS		6	V
	VBUS pin	–0.3	40	
	SDA, SCL, ALERT	–0.3	6	
	Address Pins, A0, A1	–0.3	VS + 0.3	
Open-drain digital output current, I _{OUT}			10	mA
Temperature	Junction, T _J		150	°C
	Storage, T _{stg}	–65	150	

- (1) Stresses beyond those listed under *Absolute Maximum Ratings* may cause permanent damage to the device. These are stress ratings only, which do not imply functional operation of the device at these or any other conditions beyond those indicated under *Recommended Operating Conditions*. Exposure to absolute-maximum-rated conditions for extended periods may affect device reliability.

7.2 ESD Ratings

		VALUE	UNIT
V _(ESD)	Electrostatic discharge	Human body model (HBM), per ANSI/ESDA/JEDEC JS-001 ⁽¹⁾	±2000
		Charged device model (CDM), per JEDEC specification JESD22-C101 ⁽²⁾	±1000

- (1) JEDEC document JEP155 states that 500-V HBM allows safe manufacturing with a standard ESD control process.
(2) JEDEC document JEP157 states that 250-V CDM allows safe manufacturing with a standard ESD control process.

7.3 Recommended Operating Conditions

over operating free-air temperature range (unless otherwise noted)

		MIN	NOM	MAX	UNIT
V _{CM}	Common-mode input voltage	0		36	V
VS	Operating supply voltage	2.7		5.5	V
T _A	Operating free-air temperature	–40		125	°C

7.4 Thermal Information

THERMAL METRIC ⁽¹⁾		INA260	UNIT
		PW (TSSOP)	
		16 PINS	
R _{θJA}	Junction-to-ambient thermal resistance	115.6	°C/W
R _{θJC(top)}	Junction-to-case (top) thermal resistance	50.1	°C/W
R _{θJB}	Junction-to-board thermal resistance	46.8	°C/W
ψ _{JT}	Junction-to-top characterization parameter	3.3	°C/W
ψ _{JB}	Junction-to-board characterization parameter	46.5	°C/W
R _{θJC(bot)}	Junction-to-case (bottom) thermal resistance	N/A	°C/W

- (1) For more information about traditional and new thermal metrics, see the *Semiconductor and IC Package Thermal Metrics* application report, [SPRA953](#).

7.5 Electrical Characteristics

 at $T_A = 25^\circ\text{C}$, $V_S = 3.3\text{ V}$, $V_{IN+} = 12\text{ V}$, $V_{SENSE} = (V_{IN+} - V_{IN-}) = 0\text{ mV}$ and $V_{VBUS} = 12\text{ V}$ (unless otherwise noted)

PARAMETER		TEST CONDITIONS	MIN	TYP	MAX	UNIT
INPUT						
V_{CM}	Common-mode input range		0		36	V
	Bus voltage input range ⁽¹⁾		0		36	V
CMRR	Common-mode rejection	$0\text{ V} \leq V_{IN+} \leq 36\text{ V}$		0	150	$\mu\text{A/V}$
I_{OS}	Current sense offset, RTI ⁽²⁾			± 1.25	± 5	mA
	Current sense offset drift, RTI ⁽²⁾	$-40^\circ\text{C} \leq T_A \leq 125^\circ\text{C}$		1	50	$\mu\text{A}/^\circ\text{C}$
PSRR	Current sense offset voltage, RTI ⁽²⁾ vs power supply	$2.7\text{ V} \leq V_S \leq 5.5\text{ V}$		1.6	3	mA/V
V_{OS}	Bus offset voltage, RTI ⁽²⁾			± 1.25	± 7.5	mV
	Bus offset voltage, RTI ⁽²⁾ vs temperature	$-40^\circ\text{C} \leq T_A \leq 125^\circ\text{C}$		0.6	40	$\mu\text{V}/^\circ\text{C}$
PSRR	Bus offset voltage, RTI ⁽²⁾ vs power supply			1.5		mV/V
I_B	Input bias current (I_{IN+} , I_{IN-} pins)	$(I_{IN+}\text{ pin}) + (I_{IN-}\text{ pin})$, $I_{SENSE} = 0\text{ A}$		17		μA
	VBUS input impedance			830		$\text{k}\Omega$
	Input leakage ⁽³⁾	$(I_{IN+}\text{ pin}) + (I_{IN-}\text{ pin})$, power-down mode		0.1	0.5	μA
DC ACCURACY						
System current sense gain error		$I_{SENSE} = -15\text{ A to }15\text{ A}$, $T_A = 25^\circ\text{C}$		0.02%	0.15%	
		$I_{SENSE} = -10\text{ A to }10\text{ A}$, $-40^\circ\text{C} \leq T_A \leq 125^\circ\text{C}$		0.2%	0.5%	
		$-40^\circ\text{C} \leq T_A \leq 125^\circ\text{C}$		10	35	$\text{ppm}/^\circ\text{C}$
Bus voltage gain error		$V_{BUS} = 0\text{ V to }36\text{ V}$, $T_A = 25^\circ\text{C}$		0.02%	0.1%	
		$V_{BUS} = 0\text{ V to }36\text{ V}$, $-40^\circ\text{C} \leq T_A \leq 125^\circ\text{C}$		0.1%	0.4%	
		$-40^\circ\text{C} \leq T_A \leq 125^\circ\text{C}$		15	40	$\text{ppm}/^\circ\text{C}$
INTEGRATED ADC						
	ADC native resolution			16		Bits
1-LSB step size		Current		1.25		mA
		Bus voltage		1.25		mV
		Power		10		mW
t_{CT}	ADC conversion time	CT bit = 000		140	154	μs
		CT bit = 001		204	224	
		CT bit = 010		332	365	
		CT bit = 011		588	646	
		CT bit = 100		1.1	1.21	ms
		CT bit = 101		2.116	2.328	
		CT bit = 110		4.156	4.572	
		CT bit = 111		8.244	9.068	
	Differential nonlinearity			± 0.1		LSB
INTEGRATED SHUNT						
	Package resistance	IN+ to IN-		4.5		$\text{m}\Omega$
	Maximum continuous current	$-40^\circ\text{C} \leq T_A \leq 85^\circ\text{C}$			± 15	A
	Short time overload change	$I_{SENSE} = 30\text{ A}$ for 5 seconds		$\pm 0.05\%$		

(1) Although the input range is 36 V, the full-scale range of the ADC scaling is 40.96 V; see the [Basic ADC Functions](#) section. Do not apply more than 36 V.

(2) RTI = Referred-to-input.

(3) Input leakage is positive (current flowing into the pin) for the conditions shown at the top of this table. Negative leakage currents can occur under different input conditions.

Electrical Characteristics (continued)

 at $T_A = 25^\circ\text{C}$, $V_S = 3.3\text{ V}$, $V_{IN+} = 12\text{ V}$, $V_{SENSE} = (V_{IN+} - V_{IN-}) = 0\text{ mV}$ and $V_{VBUS} = 12\text{ V}$ (unless otherwise noted)

PARAMETER	TEST CONDITIONS	MIN	TYP	MAX	UNIT
Change due to thermal shock	$-65^\circ\text{C} \leq T_A \leq 150^\circ\text{C}$, 500 cycles		$\pm 0.1\%$		
Resistance change to solder heat	260°C solder, 10 s		$\pm 0.1\%$		
High temperature exposure change	1000 hours, $T_A = 150^\circ\text{C}$		$\pm 0.15\%$		
Cold temperature storage change	24 hours, $T_A = -65^\circ\text{C}$		$\pm 0.025\%$		
SMBus					
SMBus timeout ⁽⁴⁾			28	35	ms
DIGITAL INPUT/OUTPUT					
Input capacitance			3		pF
Leakage input current	$0\text{ V} \leq V_{SCL} \leq V_S$, $0\text{ V} \leq V_{SDA} \leq V_S$, $0\text{ V} \leq V_{ALERT} \leq V_S$, $0\text{ V} \leq V_{A0} \leq V_S$, $0\text{ V} \leq V_{A1} \leq V_S$		0.1	1	μA
V_{IH} High-level input voltage		$0.7 \times V_S$		6	V
V_{IL} Low-level input voltage		0		$0.3 \times V_S$	V
V_{OL} Low-level output voltage, SDA, ALERT	$I_{OL} = 3\text{ mA}$	0		0.4	V
SDA, SCL Hysteresis			500		mV
POWER SUPPLY					
Operating supply range		2.7		5.5	V
I_Q Quiescent current			310	420	μA
Quiescent current, power-down (shutdown) mode			0.5	2	μA
V_{POR} Power-on reset threshold			2		V

(4) SMBus timeout in the INA260 resets the interface any time SCL is low for more than 28 ms.

7.6 Typical Characteristics

At $T_A = 25^\circ\text{C}$, $V_S = 3.3\text{ V}$, $V_{IN+} = 12\text{ V}$, $V_{SENSE} = (V_{IN+} - V_{IN-}) = 0\text{ mV}$ and $V_{VBUS} = 12\text{ V}$, unless otherwise noted.

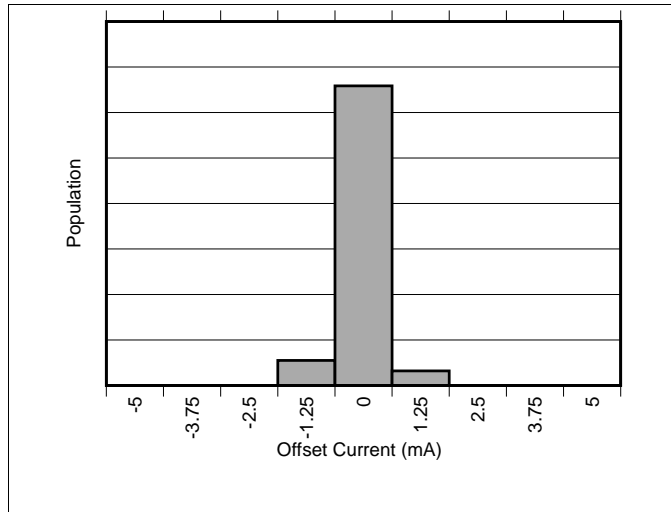

Fig. 1. Current Sense Offset Production Distribution

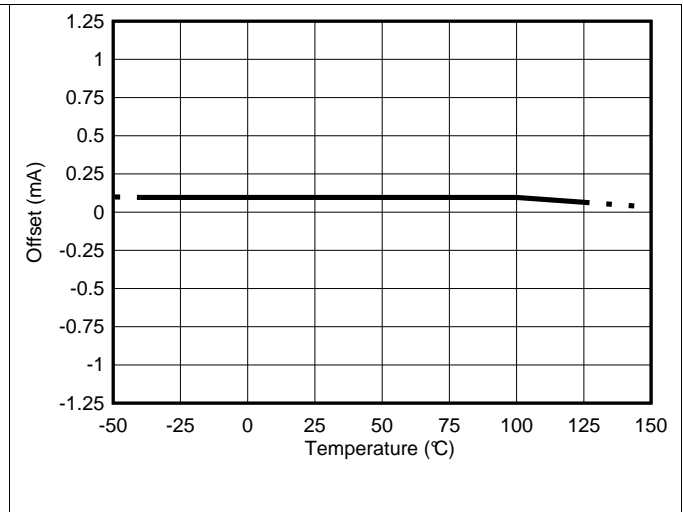

Fig. 2. Current Sense Offset vs Temperature

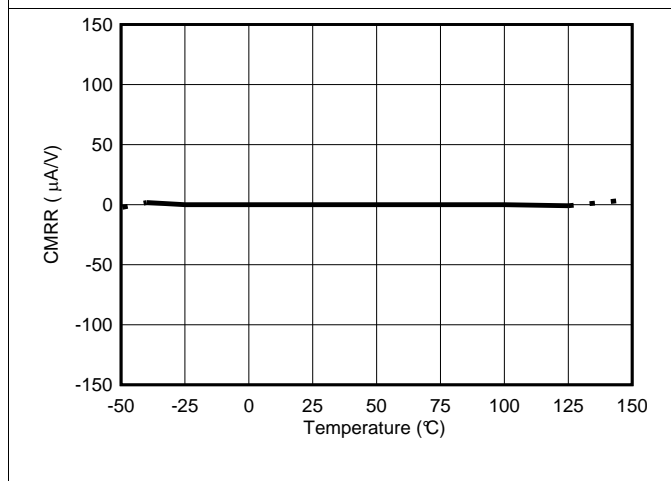

Fig. 3. Current Sense Common-Mode Rejection Ratio vs Temperature

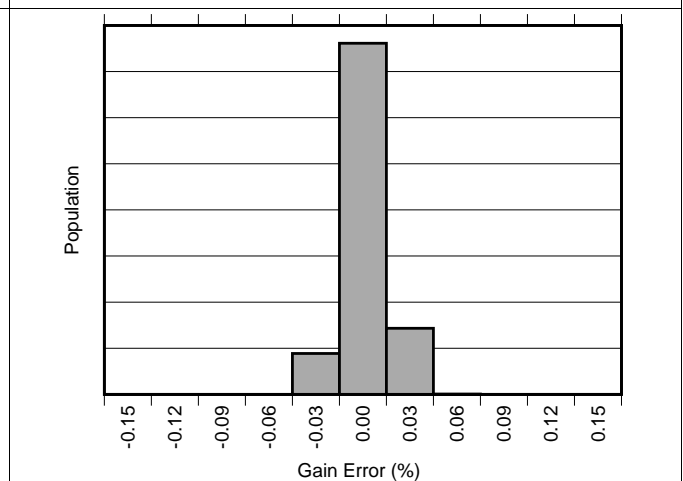

Fig. 4. Current Sense Gain Error Production Distribution

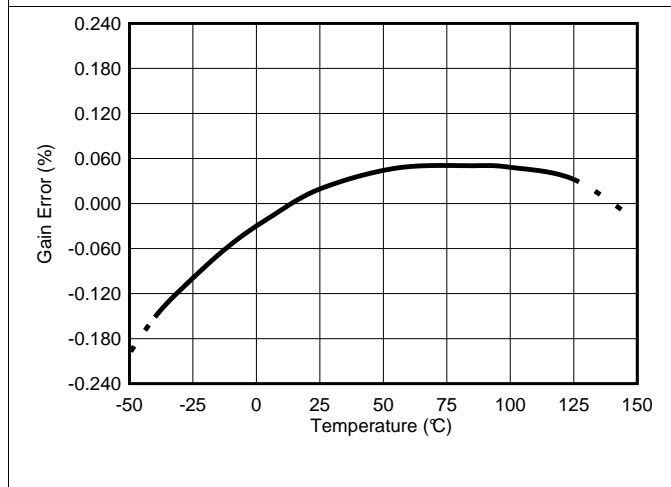

Fig. 5. Current Sense Gain Error vs Temperature

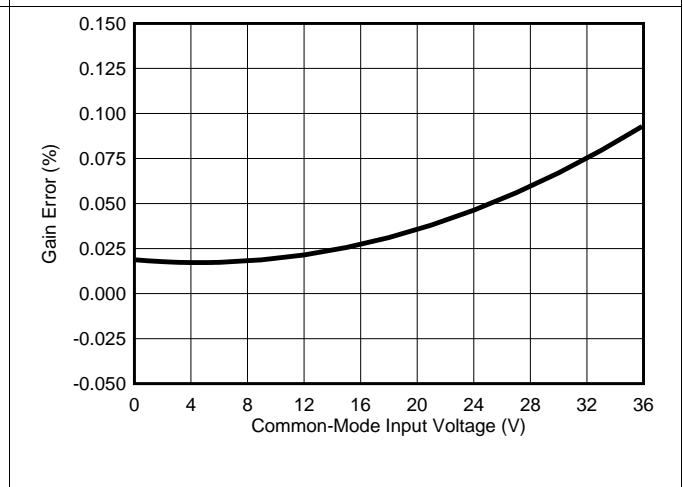

Fig. 6. Current Sense Gain Error vs Common-Mode Voltage

Typical Characteristics (continued)

At $T_A = 25^\circ\text{C}$, $V_S = 3.3\text{ V}$, $V_{IN+} = 12\text{ V}$, $V_{SENSE} = (V_{IN+} - V_{IN-}) = 0\text{ mV}$ and $V_{VBUS} = 12\text{ V}$, unless otherwise noted.

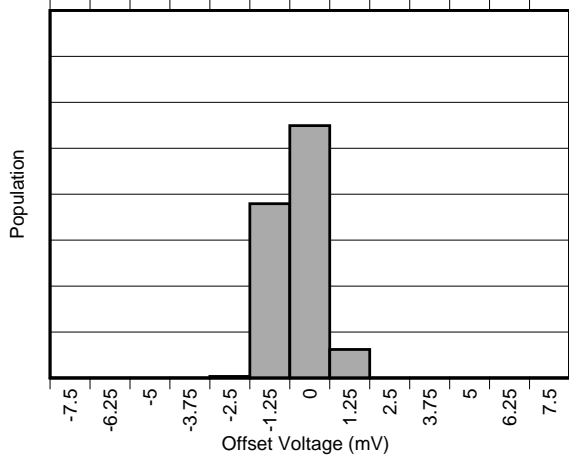

Figure 7. Bus Offset Voltage Production Distribution

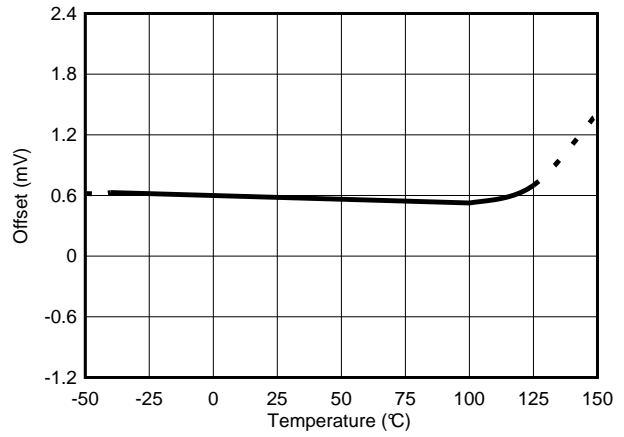

Figure 8. Bus Offset Voltage vs Temperature

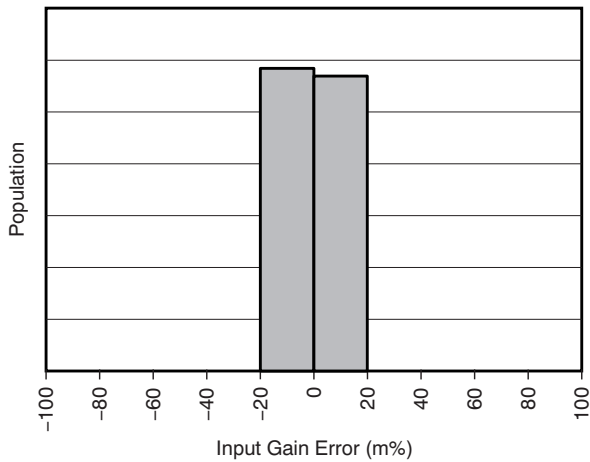

Figure 9. Bus Gain Error Production Distribution

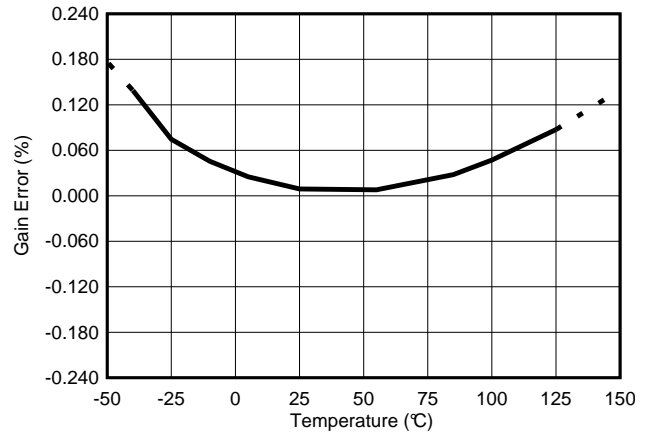

Figure 10. Bus Gain Error vs Temperature

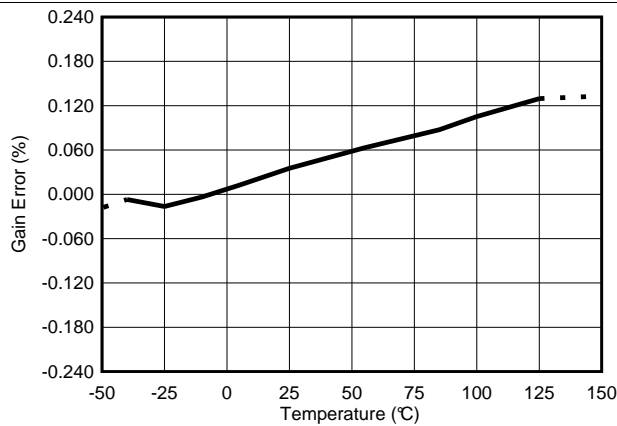

Figure 11. Power Gain Error vs Temperature

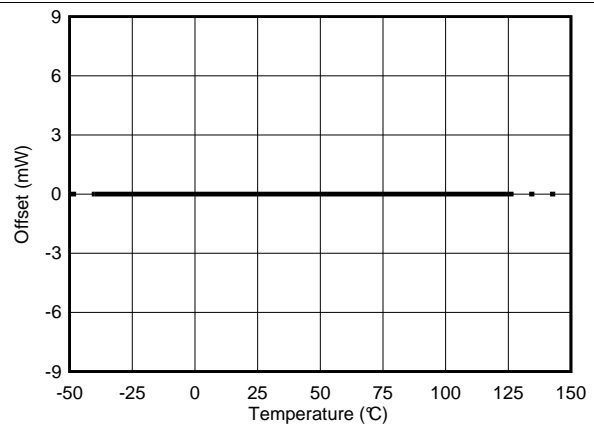
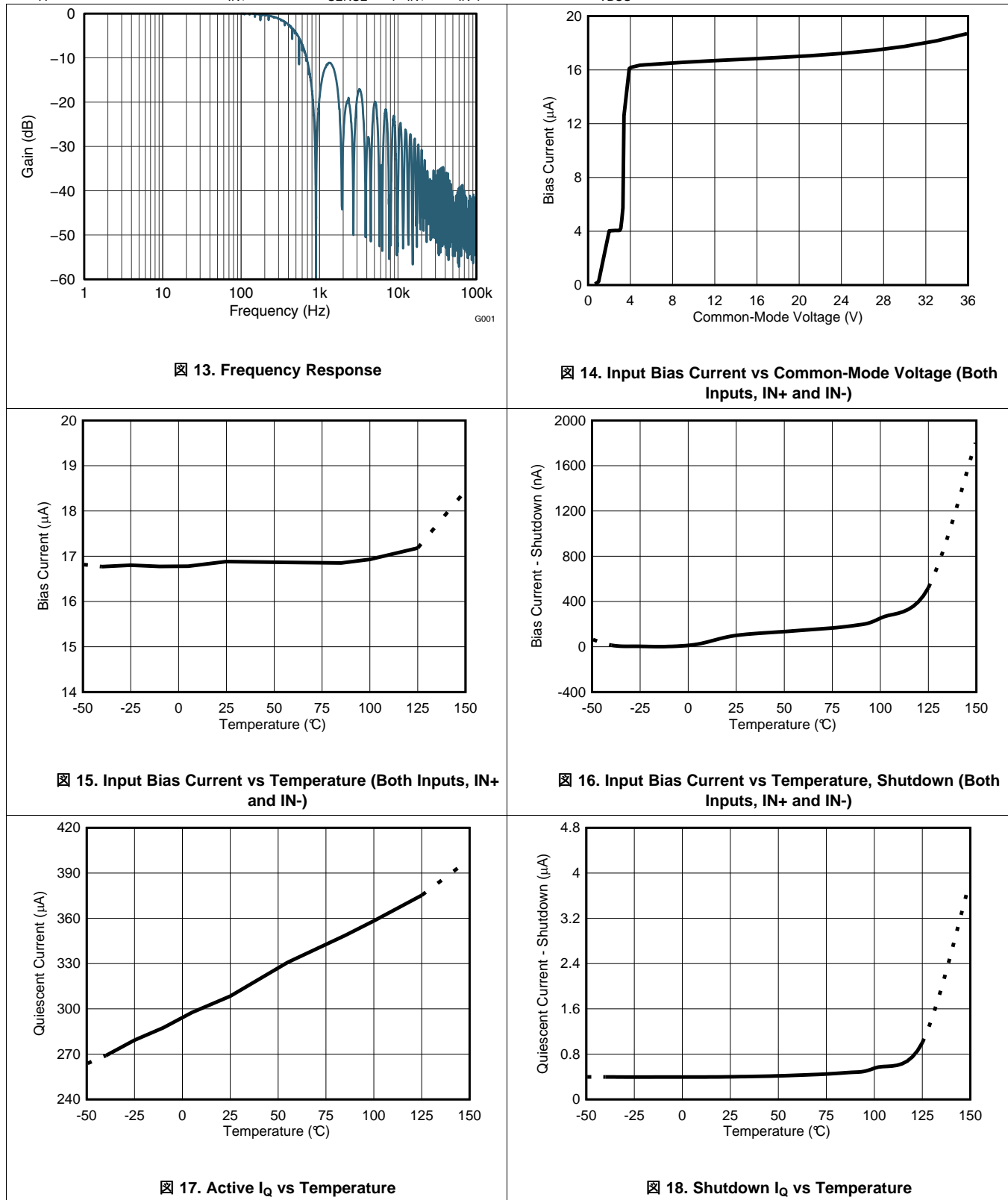

Figure 12. Power Offset Error vs Temperature

Typical Characteristics (continued)

At $T_A = 25^\circ\text{C}$, $V_S = 3.3\text{ V}$, $V_{IN+} = 12\text{ V}$, $V_{SENSE} = (V_{IN+} - V_{IN-}) = 0\text{ mV}$ and $V_{VBUS} = 12\text{ V}$, unless otherwise noted.



Typical Characteristics (continued)

At $T_A = 25^\circ\text{C}$, $V_S = 3.3\text{ V}$, $V_{IN+} = 12\text{ V}$, $V_{SENSE} = (V_{IN+} - V_{IN-}) = 0\text{ mV}$ and $V_{VBUS} = 12\text{ V}$, unless otherwise noted.

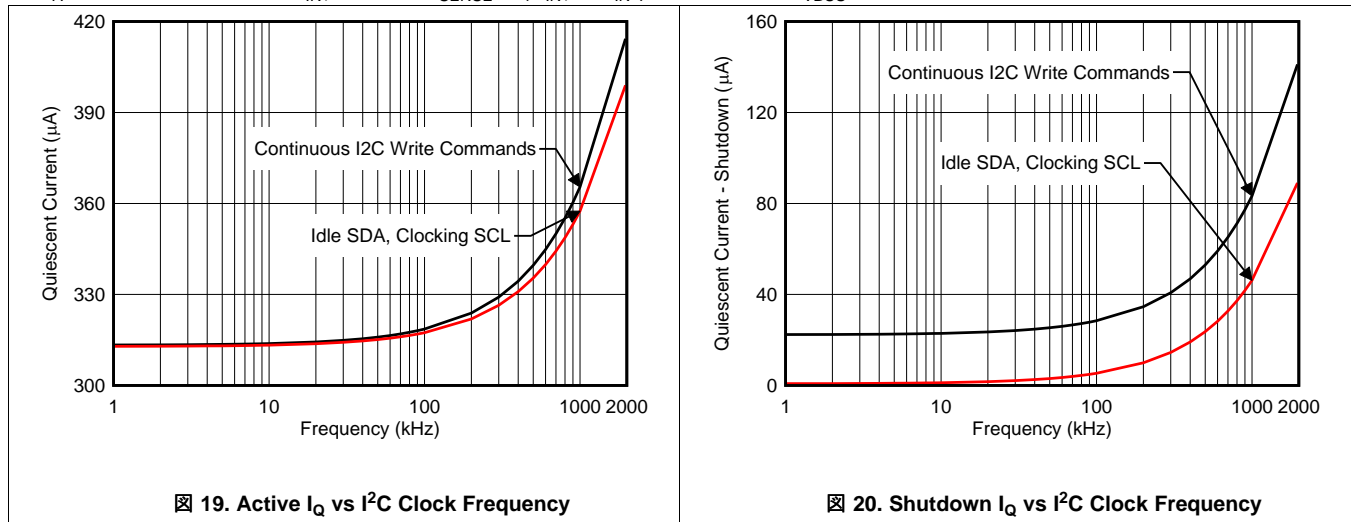

8 Detailed Description

8.1 Overview

The INA260 is an integrated shunt digital current sense amplifier with an I²C- and SMBus-compatible interface. It provides digital current, voltage, and power readings necessary for accurate decision-making in precisely-controlled systems. Programmable registers allow flexible configuration for conversion times as well as continuous-versus-triggered operation. Detailed register information appears at the end of this data sheet, beginning with 表 4. See the [Functional Block Diagram](#) section for a block diagram of the INA260 device.

8.2 Functional Block Diagram

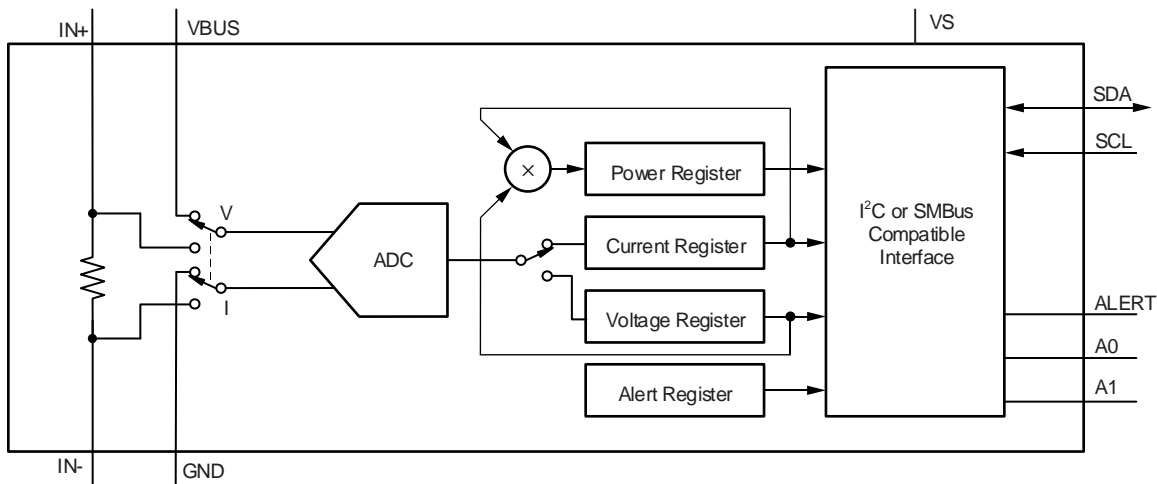

8.3 Feature Description

8.3.1 Integrated Shunt Resistor

The INA260 features a precise, low-drift, current-sensing resistor to allow for precision measurements over the entire specified temperature range of -40°C to $+125^{\circ}\text{C}$. The integrated current-sensing resistor ensures measurement stability over temperature as well as simplifying printed-circuit board (PCB) layout difficulties common in high precision current sensing measurements.

The onboard current-sensing resistor is designed as a 4-wire (or Kelvin) connected resistor that enables accurate measurements through a force-sense connection. The Kelvin connections to the shunt are done internally eliminating many of the parasitic impedances commonly found in typical very-low sensing-resistor level measurements. Although the shunt resistor can be accessed through the IN+ and IN- pins, this resistor is not intended to be used as a stand-alone component. The INA260 is internally calibrated to ensure that the current-sensing resistor and current-sensing amplifier are both precisely matched to one another.

The INA260 has approximately $4.5\text{ m}\Omega$ of total resistance between the IN+ and IN- pins. $2\text{ m}\Omega$ of this total package resistance is a precisely-controlled resistance from the Kelvin-connected current-sensing resistor used by the internal analog to digital converter (ADC). The power dissipation requirements of the system and package are based on the total $4.5\text{-m}\Omega$ package resistance. The heat dissipated across the package when current flows through the device ultimately determines the maximum current that can be safely handled by the package. The current consumption of the silicon is relatively low, leaving the total package resistance carrying the high load current as the primary contributor to the total power dissipation of the package. The maximum safe-operating current level is set to ensure that the heat dissipated across the package is limited so that no damage to the resistor or the package itself occurs or that the internal junction temperature of the silicon does not exceed a 150°C limit.

Feature Description (continued)

External factors (such as ambient temperature, external air flow, and PCB layout) can contribute to how effectively the heat developed as a result of the current flowing through the total package resistance can be removed from within the device. Under the conditions of no air flow, a maximum ambient temperature of 85°C, and 1-oz. copper input power planes, the INA260 can accommodate continuous current levels up to 15 A. As shown in [Figure 21](#), the current handling capability is derated at temperatures above the 85°C level with safe operation up to 10 A at a 125°C ambient temperature. With air flow and larger 2-oz. copper input power planes, the INA260 can safely accommodate continuous current levels up to 15 A over the entire -40°C to +125°C temperature range.

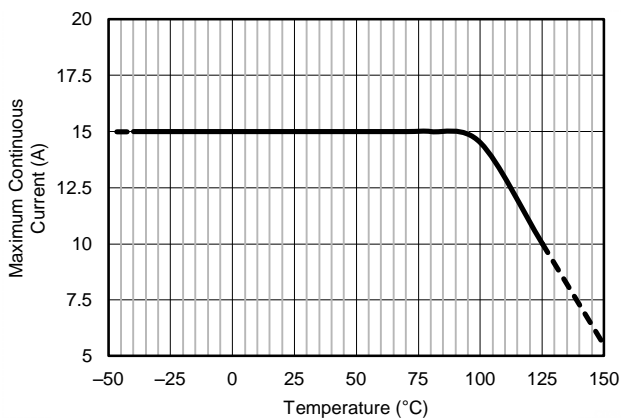
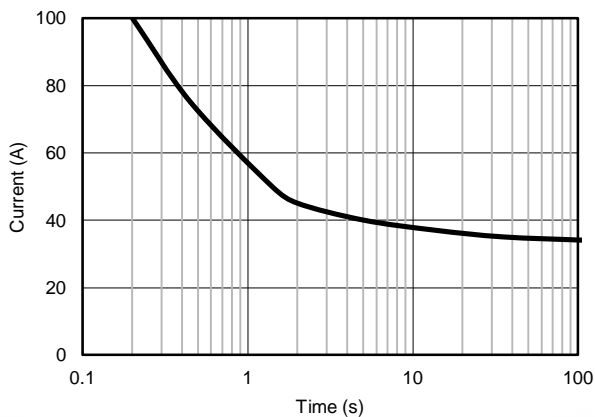

Figure 21. Maximum Current vs Temperature

8.3.2 Over-Current Capability

The INA260 features a physical shunt resistance that is able to withstand current levels higher than the continuous handling limit of 15 A without sustaining damage to the current-sensing resistor or the current-sensing amplifier if the excursions are very brief. [Figure 22](#) shows the maximum overload current versus time curve for the INA260.

注意
Operation at or above this curve, [Figure 22](#), can result in device damage or permanent erroneous current readings.



$T_A = 25^\circ\text{C}$

Figure 22. Maximum Overload Current vs Time

Feature Description (continued)

8.3.3 Basic ADC Functions

The INA260 device performs two measurements on the power-supply bus of interest. The current which is internally calculated by measuring the voltage developed across a known internal shunt resistor, and the power supply bus voltage from the external VBUS pin to ground.

The device is typically powered by a separate supply that can range from 2.7 V to 5.5 V. The bus that is being monitored can range in voltage from 0 V to 36 V. Based on the fixed 1.25-mV LSB for the Bus Voltage Register that a full-scale register results in a 40.96 V value.

注

Do not apply more than 36 V of actual voltage to the input pins.

There are no special considerations for power-supply sequencing because the common-mode input range and power-supply voltage are independent of each other; therefore, the bus voltage can be present with the supply voltage off, and vice-versa.

The device has two operating modes, continuous and triggered, that determine how the ADC operates following these conversions. When the device is in the normal operating mode (that is, MODE bits of the Configuration Register (00h) are set to '111'), it continuously converts an internal shunt voltage reading followed by a bus voltage reading. After the measurement of the internal shunt voltage reading, the current value is calculated. This current value is then used to calculate the power result. These values are subsequently stored in an accumulator, and the measurement/calculation sequence repeats until the number of averages set in the Configuration Register (00h) is reached. Following every sequence, the present set of values, measured and calculated, are appended to previously collected values. After all of the averaging has been completed, the final values for bus voltage, current, and power are updated in the corresponding registers that can then be read. These values remain in the data output registers until they are replaced by the next fully completed conversion results. Reading the data output registers does not affect a conversion in progress.

The mode control in the Configuration Register (00h) also permits selecting modes to convert only the current or the bus voltage in order to further allow the user to configure the monitoring function to fit the specific application requirements.

In triggered mode, writing any of the triggered convert modes into the Configuration Register (00h) (that is, MODE bits of the Configuration Register (00h) are set to '001', '010', or '011') triggers a single-shot conversion. This action produces a single set of measurements; thus, to trigger another single-shot conversion, the Configuration Register (00h) must be written to a second time, even if the mode does not change.

In addition to the two operating modes (continuous and triggered), the device also has a power-down mode that reduces the quiescent current and turns off current into the device inputs, reducing the impact of supply drain when the device is not being used. Full recovery from power-down mode requires 40 μ s. The registers of the device can be written to and read from while the device is in power-down mode. The device remains in power-down mode until one of the active modes settings are written into the Configuration Register (00h) .

Although the device can be read at any time, and the data from the last conversion remain available, the Conversion Ready flag bit (Mask/Enable Register, CVRF bit) is provided to help coordinate one-shot or triggered conversions. The Conversion Ready flag (CVRF) bit is set after all conversions, averaging, and multiplication operations are complete.

The Conversion Ready flag (CVRF) bit clears under these conditions:

- Writing to the Configuration Register (00h), except when configuring the MODE bits for power-down mode; or
- Reading the Mask/Enable Register (06h)

8.3.3.1 Power Calculation

The power is calculated following current and bus voltage measurements; see [Figure 23](#). Calculations for both the current and power are performed in the background and do not add to the overall conversion time. These current and power values are considered intermediate results (unless the averaging is set to 1) and are stored in an internal accumulation register, not the corresponding output registers. Following every measured sample, the newly-calculated values for current and power are appended to this accumulation register until all of the samples have been measured and averaged based on the number of averages set in the Configuration Register (00h).

Feature Description (continued)

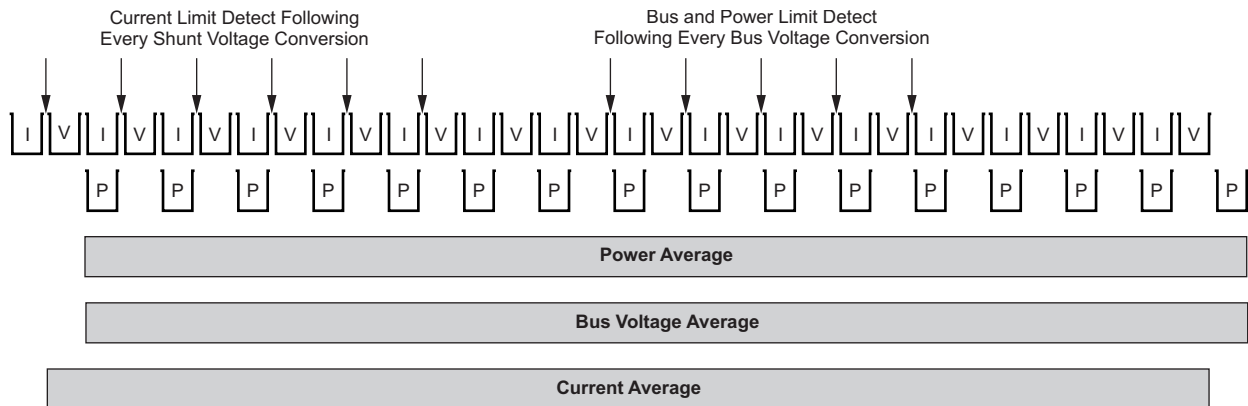

NOTE: I = current, V = voltage, and P = power.

23. Power Calculation Scheme

In addition to the current and power accumulating after every sample, the bus voltage measurement is also collected. After all of the samples have been measured and the corresponding current and power calculations have been made, the accumulated average for each of these parameters is then loaded to the corresponding output registers, where they can be read.

8.3.3.2 ALERT Pin

The INA260 has a single Alert Limit Register (07h), that allows the ALERT pin to be programmed to respond to a single user-defined event or to a Conversion Ready notification if desired. The Mask/Enable Register allows the user to select from one of the five available functions to monitor as well as setting the Conversion Ready bit to control the response of the ALERT pin. Based on the function being monitored, enter a value into the Alert Limit Register to set the corresponding threshold value that asserts the ALERT pin.

The ALERT pin allows for one of several available alert functions to be monitored to determine if a user-defined threshold has been exceeded. The five alert functions that can be monitored are:

- Shunt Over Current-Limit (OCL)
- Shunt Under Current-Limit (UCL)
- Bus Voltage Over-Limit (BOL)
- Bus Voltage Under-Limit (BUL)
- Power Over-Limit (POL)

The ALERT pin is an open-drain output. This pin is asserted when the alert function selected in the Mask/Enable Register exceeds the value programmed into the Alert Limit Register. Only one of these alert functions can be enabled and monitored at a time. If multiple alert functions are enabled, the selected function in the highest significant bit position takes priority and responds to the Alert Limit Register value. For example, if the shunt over and under current limit functions are both selected, the Alert pin asserts when the shunt current exceeds the value in the Alert Limit Register.

The Conversion Ready state of the device can also be monitored at the ALERT pin to inform the user when the device has completed the previous conversion and is ready to begin a new conversion. Conversion Ready can be monitored at the ALERT pin along with one of the alert functions. If an alert function and the Conversion Ready are both enabled to be monitored at the ALERT pin, after the ALERT pin is asserted, the Mask/Enable Register must be read following the alert to determine the source of the alert. By reading the Conversion Ready Flag (CVRF, bit 3), and the Alert Function Flag (AFF, bit 4) in the Mask/Enable Register, the source of the alert can be determined. If the Conversion Ready feature is not desired and the CNVR bit is not set, the ALERT pin only responds to an exceeded alert limit based on the alert function enabled.

If the alert function is not used, the ALERT pin can be left floating without impacting the operation of the device.

Feature Description (continued)

Refer to [Figure 23](#) to see the relative timing of when the value in the Alert Limit Register is compared to the corresponding converted value. For example, if the alert function that is enabled is Shunt Overcurrent-Limit (OCL), following every shunt current conversion the value in the Alert Limit Register is compared to the measured shunt voltage to determine if the measurements has exceeded the programmed limit. The AFF, bit 4 of the Mask/Enable Register, asserts high any time the measured voltage exceeds the value programmed into the Alert Limit Register. In addition to the AFF being asserted, the Alert pin is asserted based on the Alert Polarity Bit (APOL, bit 1 of the Mask/Enable Register). If the Alert Latch is enabled, the AFF and Alert pin remain asserted until either the Configuration Register (00h) is written to or the Mask/Enable Register is read.

The Bus Voltage alert functions compare the measured bus voltage to the Alert Limit Register following every bus voltage conversion and assert the AFF bit and ALERT pin if the limit threshold is exceeded.

The Power Over-Limit alert function is also compared to the calculated power value following every bus voltage measurement conversion and asserts the AFF bit and ALERT pin if the limit threshold is exceeded.

8.4 Device Functional Modes

8.4.1 Averaging and Conversion Time Considerations

The INA260 device offers programmable conversion times (t_{CT}) for both the shunt current and bus voltage measurements. The conversion times for these measurements can be selected from as fast as 140 μ s to as long as 8.244 ms. The conversion time settings, along with the programmable averaging mode, allow the device to be configured to optimize the available timing requirements in a given application. For example, if a system requires that data be read every 5 ms, the device could be configured with the conversion times set to 588 μ s for both shunt and bus voltage measurements and the averaging mode set to 4. This configuration results in the data updating approximately every 4.7 ms. The device could also be configured with a different conversion time setting for the shunt and bus voltage measurements. This type of approach is common in applications where the bus voltage tends to be relatively stable. This situation allows reduced time focused on the bus voltage measurement relative to the shunt voltage measurement. The shunt voltage conversion time could be set to 4.156 ms with the bus voltage conversion time set to 588 μ s and with the averaging mode set to 1. This configuration also results in data updating approximately every 4.7 ms.

There are trade-offs associated with the settings for conversion time and the averaging mode used. The averaging feature can significantly improve the measurement accuracy by effectively filtering the signal. This approach allows the device to reduce any noise in the measurement that may be caused by noise coupling into the signal. A greater number of averages enables the device to be more effective in reducing the noise component of the measurement.

The conversion times selected can also have an impact on the measurement accuracy. [Figure 24](#) shows multiple conversion times to illustrate the impact of noise on the measurement. To achieve the highest accuracy measurement possible, use a combination of the longest allowable conversion times and highest number of averages, based on the timing requirements of the system.

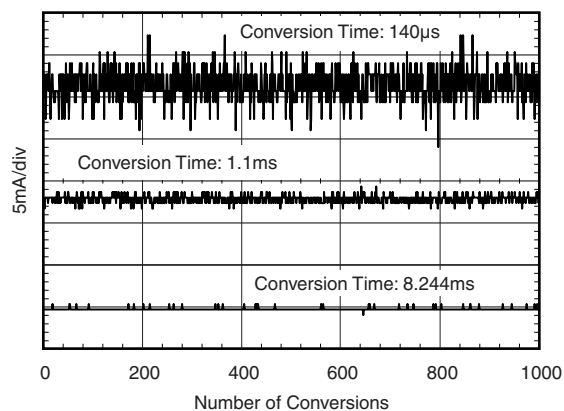

Figure 24. Noise vs Conversion Time

8.5 Programming

8.5.1 Calculating Returned Values

The LSB size for the Bus Voltage Register (02h), Current Register, and Power Register are fixed and are shown in [表 1](#). To calculate any of the values for current, voltage or power take the decimal value returned by the device and multiply that value by the LSB size. For example, the LSB for the bus voltage is 1.25 mV/bit, if the device returns a decimal value of 9584 (2570h), the value of the bus voltage is calculated to be $1.25 \text{ mV} \times 9584 = 11.98 \text{ V}$. Because the INA260 supports current measurements in either direction, the returned value for negative currents (currents flowing from IN- to IN+) is represented in two's complement format. Returned values for power will always be positive even when the current is negative.

表 1. Calculating Current and Power⁽¹⁾

REGISTER NAME	ADDRESS	CONTENTS	DEC	LSB	VALUE
Current Register	01h	2710h	10000	1.25 mA	12.5 A
Bus Voltage Register	02h	2570h	9584	1.25 mV	11.98 V
Power Register	03h	3A7Fh	14975	10 mW	149.75 W

(1) Conditions: Load = 12.5 A, $V_{CM} = 11.98 \text{ V}$.

8.5.2 Default Settings

The default power-up states of the registers are shown in the [Register Maps](#) section of this data sheet. These registers are volatile, and if programmed to a value other than the default values shown in [表 4](#), they must be re-programmed at every device power-up.

8.5.3 Communications Bus Overview

The INA260 offers compatibility with both I²C and SMBus interfaces. The I²C and SMBus protocols are essentially compatible with one another.

The I²C interface is used throughout this data sheet as the primary example, with SMBus protocol specified only when a difference between the two systems is discussed. Two lines, SCL and SDA, connect the device to the bus. Both SCL and SDA connect to the bus and require external pullup resistors.

The device that initiates a data transfer is called a *master*, and the devices controlled by the master are *slaves*. The bus must be controlled by a master device that generates the serial clock (SCL), controls the bus access, and generates START and STOP conditions. The SCL pin on the INA260 is an input only and will not stretch the clock by holding the clock line low.

To address a specific device, the master initiates a start condition by pulling the data signal line (SDA) from a high to a low logic level while SCL is high. All slaves on the bus shift in the slave address byte on the rising edge of SCL, with the last bit indicating whether a read or write operation is intended. During the ninth clock pulse, the slave being addressed responds to the master by generating an Acknowledge and pulling SDA low.

Data transfer is then initiated and eight bits of data are sent, followed by an *Acknowledge* bit. During data transfer, SDA must remain stable while SCL is high. Any change in SDA while SCL is high is interpreted as a start or stop condition.

After all data have been transferred, the master generates a stop condition, indicated by pulling SDA from low to high while SCL is high. The device includes a 28-ms timeout on its interface to prevent locking up the bus.

8.5.3.1 Serial Bus Address

To communicate with the device, the master must first address the INA260 through a slave address byte. The slave address byte consists of seven address bits and a direction bit that indicates whether the action is to be a read or write operation.

The device has two address pins, A0 and A1 that can be connected to GND, VS, SCL or SDA to set the desired address. [表 2](#) lists the pin connections for each of the 16 possible addresses. The device samples the state of pins A0 and A1 on every bus communication in order to establish the pin states before any activity on the interface occurs.

表 2. Address Pins and Slave Addresses

A1	A0	SLAVE ADDRESS
GND	GND	1000000
GND	VS	1000001
GND	SDA	1000010
GND	SCL	1000011
VS	GND	1000100
VS	VS	1000101
VS	SDA	1000110
VS	SCL	1000111
SDA	GND	1001000
SDA	VS	1001001
SDA	SDA	1001010
SDA	SCL	1001011
SCL	GND	1001100
SCL	VS	1001101
SCL	SDA	1001110
SCL	SCL	1001111

8.5.3.2 Serial Interface

The INA260 operates only as a slave device on both the I²C bus and the SMBus. Connections to the bus are made through the open-drain SDA and SCL lines. The SDA and SCL pins feature integrated spike suppression filters and Schmitt triggers to minimize the effects of input spikes and bus noise. Although the device integrates spike suppression into the digital I/O lines, proper layout techniques help minimize the amount of coupling into the communication lines. This noise introduction could occur from capacitively coupling signal edges between the two communication lines themselves or from other switching noise sources present in the system. Routing traces in parallel with ground in between layers on a PCB typically reduces the effects of coupling between the communication lines. Shielded communication lines reduces the possibility of unintended noise coupling into the digital I/O lines that could be incorrectly interpreted as start or stop commands.

The INA260 supports the transmission protocol for fast mode (1 kHz to 400 kHz) and high-speed mode (1 kHz to 2.94 MHz). All data bytes are transmitted most significant byte first.

8.5.3.3 Writing to and Reading From the INA260

Accessing a specific register on the INA260 is accomplished by writing the appropriate value to the register pointer. See 表 4 for a complete list of registers and corresponding addresses. The value for the register pointer (as shown in 图 28) is the first byte transferred after the slave address byte with the R/W bit low. Every write operation to the device requires a value for the register pointer.

Writing to a register begins with the first byte transmitted by the master. This byte is the slave address, with the R/W bit low. The device then acknowledges receipt of a valid address. The next byte transmitted by the master is the address of the register which data is written to. This register address value updates the register pointer to the desired register. The next two bytes are written to the register addressed by the register pointer. The device acknowledges receipt of each data byte. The master may terminate data transfer by generating a start or stop condition.

When reading from the device, the last value stored in the register pointer by a write operation determines which register is read during a read operation. To change the register pointer for a read operation, a new value must be written to the register pointer. This write is accomplished by issuing a slave address byte with the R/W bit low, followed by the register pointer byte. No additional data are required. The master then generates a start condition and sends the slave address byte with the R/W bit high to initiate the read command. The next byte is transmitted by the slave and is the most significant byte of the register indicated by the register pointer. This byte is followed by an *Acknowledge* from the master; then the slave transmits the least significant byte. The master acknowledges receipt of the data byte. The master may terminate data transfer by generating a *Not-Acknowledge* after receiving any data byte, or generating a start or stop condition. If repeated reads from the same register are desired, it is not necessary to continually send the register pointer bytes; the device retains the register pointer value until it is changed by the next write operation.

Figure 25 shows the write operation timing diagram. Figure 26 shows the read operation timing diagram.

注

Register bytes are sent most-significant byte first, followed by the least significant byte.

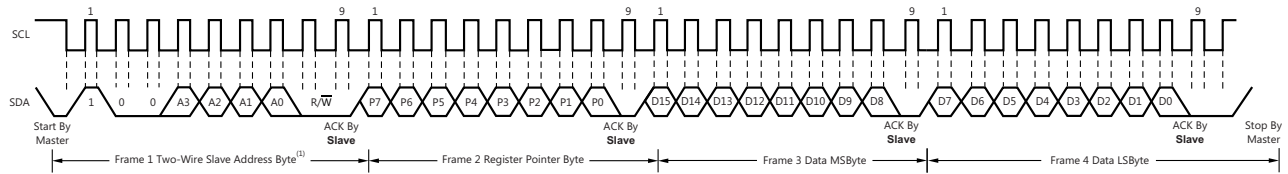

(1) The value of the Slave Address byte is determined by the settings of the A0 and A1 pins. See Table 2.

Figure 25. Timing Diagram for Write Word Format

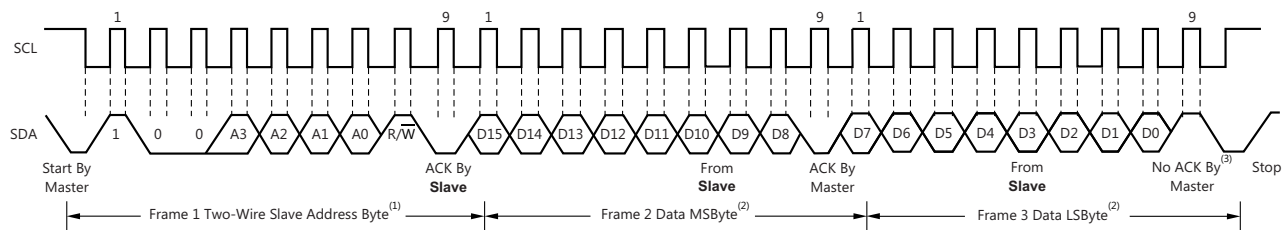

(1) The value of the Slave Address byte is determined by the settings of the A0 and A1 pins. See Table 2.

(2) Read data is from the last register pointer location. If a new register is desired, the register pointer must be updated. See Figure 28.

(3) ACK by Master can also be sent.

Figure 26. Timing Diagram for Read Word Format

Figure 27 provides a timing diagram for the SMBus Alert response operation. Figure 28 illustrates a typical register pointer configuration.

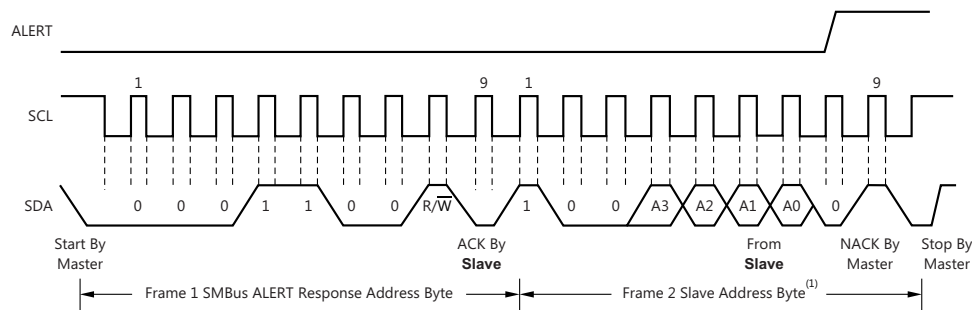

(1) The value of the Slave Address Byte is determined by the settings of the A0 and A1 pins. See Table 2.

Figure 27. Timing Diagram for SMBus ALERT Response

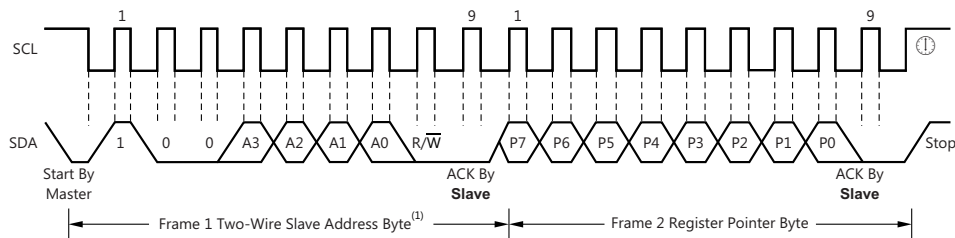

(1) The value of the Slave Address Byte is determined by the settings of the A0 and A1 pins. See Table 2.

Figure 28. Typical Register Pointer Set

8.5.3.3.1 High-Speed I²C Mode

To initiate high-speed mode operation, the master generates a start condition followed by a valid serial byte containing high-speed (HS) master code *00001XXX*. This transmission is made in fast (400 kHz) or standard (100 kHz) (F/S) mode at no more than 400 kHz. When the INA260 receives the high-speed code it does not send an acknowledgement but does change the internal logic deglitch filters to support high-speed operation.

The master then generates a repeated start condition (a repeated start condition has the same timing as the start condition). After this repeated start condition, the protocol is the same as F/S mode, except that transmission speeds up to 2.94 MHz are allowed. Instead of using a stop condition, use repeated start conditions to secure the bus in HS-mode. A stop condition ends the HS-mode and switches all the internal filters of the device to support the F/S mode. See [Figure 29](#) and [Table 3](#) for relevant fast mode and high-speed mode timing requirements.



图 29. Bus Timing Diagram

表 3. Bus Timing Diagram Definitions⁽¹⁾

PARAMETER		FAST MODE		HIGH-SPEED MODE		UNIT
		MIN	MAX	MIN	MAX	
SCL operating frequency	$f_{(SCL)}$	0.001	0.4	0.001	2.94	MHz
Bus free time between stop and start conditions	$t_{(BUF)}$	600		160		ns
Hold time after repeated START condition. After this period, the first clock is generated.	$t_{(HDSTA)}$	100		100		ns
Repeated start condition setup time	$t_{(SUSTA)}$	100		100		ns
STOP condition setup time	$t_{(SUSTO)}$	100		100		ns
Data hold time	$t_{(HDDAT)}$	10	900	10	100	ns
Data setup time	$t_{(SUDAT)}$	100		20		ns
SCL clock low period	$t_{(LOW)}$	1300		200		ns
SCL clock high period	$t_{(HIGH)}$	600		60		ns
Data fall time	t_F		300		80	ns
Clock fall time	t_F		300		40	ns
Clock rise time	t_R		300		40	ns
Clock/data rise time for $SCLK \leq 100kHz$	t_R		1000		—	ns

(1) Values based on a statistical analysis of a one-time sample of devices. Minimum and maximum values are specified by design, but not production tested.

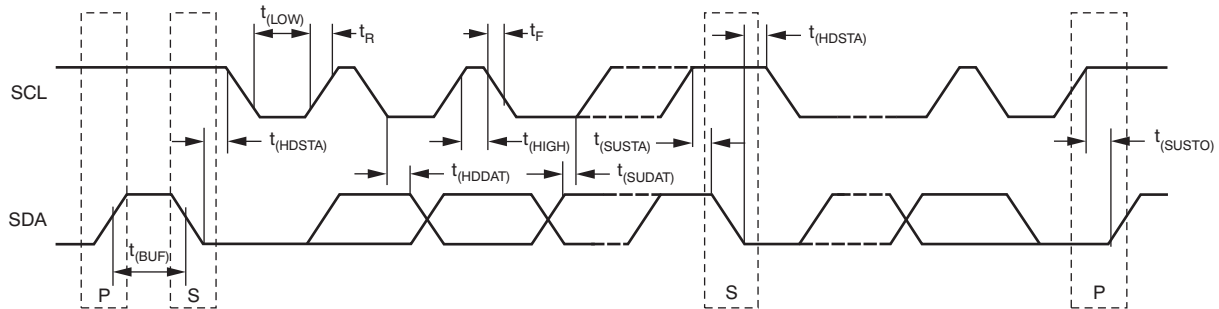
8.5.3.4 SMBus Alert Response

When SMBus Alerts are latched, the INA260 is designed to respond to the SMBus Alert Response address. The SMBus Alert Response provides a quick fault identification for simple slave devices. When an Alert occurs, the master can broadcast the Alert Response slave address (0001 100) with the Read/Write bit set high. Following this Alert Response, any slave device that generates an alert identifies itself by acknowledging the Alert Response and sending its address on the bus.

The Alert Response can activate several different slave devices simultaneously, similar to the I²C General Call. If more than one slave attempts to respond, bus arbitration rules apply and the device with the lowest address will win and be serviced first. The losing devices do not generate an Acknowledge and continues to hold the Alert line low until the interrupt is cleared. The winning device responds with its address and releases the SMBus alert line. Even though the INA260 releases the SMBus line the internal error flags are not cleared until done so by the host.

8.6 Register Maps

The INA260 uses a bank of registers for holding configuration settings, measurement results, minimum/maximum limits, and status information. 表 4 summarizes the device registers; see the [Functional Block Diagram](#) section for an illustration of the registers.

表 4. Register Set Summary

POINTER ADDRESS	REGISTER NAME	FUNCTION	POWER-ON RESET		TYPE ⁽¹⁾
			BINARY	HEX	
00h	Configuration Register	All-register reset, shunt voltage and bus voltage ADC conversion times and averaging, operating mode.	01100001 00100111	6127	R/ \overline{W}
01h	Current Register	Contains the value of the current flowing through the shunt resistor.	00000000 00000000	0000	R
02h	Bus Voltage Register	Bus voltage measurement data.	00000000 00000000	0000	R
03h	Power Register	Contains the value of the calculated power being delivered to the load.	00000000 00000000	0000	R
06h	Mask/Enable Register	Alert configuration and Conversion Ready flag.	00000000 00000000	0000	R/ \overline{W}
07h	Alert Limit Register	Contains the limit value to compare to the selected Alert function.	00000000 00000000	0000	R/ \overline{W}
FEh	Manufacturer ID Register	Contains unique manufacturer identification number.	0101010001001001	5449	R
FFh	Die ID Register	Contains unique die identification number.	0010001001110000	2270	R

(1) Type: R = Read-Only, R/ \overline{W} = Read/Write.

8.6.1 Configuration Register (00h) (Read/Write)

The Configuration Register settings control the operating modes for the device. This register controls the conversion time settings for both shunt current and bus voltage measurements as well as the averaging mode used. The operating mode that controls what signals are selected to be measured is also programmed in the Configuration Register.

The Configuration Register can be read from at any time without impacting or affecting the device settings or a conversion in progress. Writing to the Configuration Register halts any conversion in progress until the write sequence is completed resulting in a new conversion starting based on the new contents of the Configuration Register (00h). This halt prevents any uncertainty in the conditions used for the next completed conversion.

☒ 30. Configuration Register (00h) (Read/Write)

15	14	13	12	11	10	9	8
RST	—	—	—	AVG2	AVG1	AVG0	VBUSCT2
0	1	1	0	0	0	0	1
R/W	R			R/W			
7	6	5	4	3	2	1	0
VBUSCT1	VBUSCT0	ISHCT2	ISHCT1	ISHCT0	MODE3	MODE2	MODE1
0	0	1	0	0	1	1	1
R/W							

LEGEND: R/W = Read/Write; R = Read only; -n = value after reset

表 5. Configuration Register Field Descriptions

Bit	Field	Type	Reset	Description
15	RST	R/W	0	Reset Bit Setting this bit to '1' generates a system reset that is the same as power-on reset. Resets all registers to default values; this bit self-clears.
14–12	—	R	110	
11–9	AVG	R/W	000	Averaging Mode Determines the number of samples that are collected and averaged. The following shows all the AVG bit settings and related number of averages for each bit setting. AVG2 = 0, AVG1 = 0, AVG0 = 0, number of averages = 1 ⁽¹⁾ AVG2 = 0, AVG1 = 0, AVG0 = 1, number of averages = 4 AVG2 = 0, AVG1 = 1, AVG0 = 0, number of averages = 16 AVG2 = 0, AVG1 = 1, AVG0 = 1, number of averages = 64 AVG2 = 1, AVG1 = 0, AVG0 = 0, number of averages = 128 AVG2 = 1, AVG1 = 0, AVG0 = 1, number of averages = 256 AVG2 = 1, AVG1 = 1, AVG0 = 0, number of averages = 512 AVG2 = 1, AVG1 = 1, AVG0 = 1, number of averages = 1024
8–6	VBUSCT	R/W	100	Bus Voltage Conversion Time Sets the conversion time for the bus voltage measurement. The following shows the VBUSCT bit options and related conversion times for each bit setting. VBUSCT2 = 0, VBUSCT1 = 0, VBUSCT0 = 0, conversion time = 140 μs VBUSCT2 = 0, VBUSCT1 = 0, VBUSCT0 = 1, conversion time = 204 μs VBUSCT2 = 0, VBUSCT1 = 1, VBUSCT0 = 0, conversion time = 332 μs VBUSCT2 = 0, VBUSCT1 = 1, VBUSCT0 = 1, conversion time = 588 μs VBUSCT2 = 1, VBUSCT1 = 0, VBUSCT0 = 0, conversion time = 1.1 ms ⁽¹⁾ VBUSCT2 = 1, VBUSCT1 = 0, VBUSCT0 = 1, conversion time = 2.116 ms VBUSCT2 = 1, VBUSCT1 = 1, VBUSCT0 = 0, conversion time = 4.156 ms VBUSCT2 = 1, VBUSCT1 = 1, VBUSCT0 = 1, conversion time = 8.244 ms
5–3	ISHCT	R/W	100	Shunt Current Conversion Time The following shows the ISHCT bit options and related conversion times for each bit setting. ISHCT2 = 0, ISHCT1 = 0, ISHCT0 = 0, conversion time = 140 μs ISHCT2 = 0, ISHCT1 = 0, ISHCT0 = 1, conversion time = 204 μs ISHCT2 = 0, ISHCT1 = 1, ISHCT0 = 0, conversion time = 332 μs ISHCT2 = 0, ISHCT1 = 1, ISHCT0 = 1, conversion time = 588 μs ISHCT2 = 1, ISHCT1 = 0, ISHCT0 = 0, conversion time = 1.1 ms ⁽¹⁾ ISHCT2 = 1, ISHCT1 = 0, ISHCT0 = 1, conversion time = 2.116 ms ISHCT2 = 1, ISHCT1 = 1, ISHCT0 = 0, conversion time = 4.156 ms ISHCT2 = 1, ISHCT1 = 1, ISHCT0 = 1, conversion time = 8.244 ms
2–0	MODE	R/W	111	Operating Mode Selects continuous, triggered, or power-down mode of operation. These bits default to continuous shunt and bus measurement mode. The following shows mode settings. MODE2 = 0, MODE1 = 0, MODE0 = 0, mode = Power-Down (or Shutdown) MODE2 = 0, MODE1 = 0, MODE0 = 1, mode = Shunt Current, Triggered MODE2 = 0, MODE1 = 1, MODE0 = 0, mode = Bus Voltage, Triggered MODE2 = 0, MODE1 = 1, MODE0 = 1, mode = Shunt Current and Bus Voltage, Triggered MODE2 = 1, MODE1 = 0, MODE0 = 0, mode = Power-Down (or Shutdown) MODE2 = 1, MODE1 = 0, MODE0 = 1, mode = Shunt Current, Continuous MODE2 = 1, MODE1 = 1, MODE0 = 0, mode = Bus Voltage, Continuous MODE2 = 1, MODE1 = 1, MODE0 = 1, mode = Shunt Current and Bus Voltage, Continuous ⁽¹⁾

(1) These values are default.

8.6.2 Current Register (01h) (Read-Only)

The value in the current register is represented in two's complement format to support negative current values. The LSB size for the current register is set to 1.25 mA. If averaging is enabled, this register will report the averaged value.

☒ **31. Current Register (01h) (Read-Only)**

15	14	13	12	11	10	9	8
CSIGN	CD14	CD13	CD12	CD11	CD10	CD9	CD8
0	0	0	0	0	0	0	0
R							
7	6	5	4	3	2	1	0
CD7	CD6	CD5	CD4	CD3	CD2	CD1	CD0
0	0	0	0	0	0	0	0
R							

LEGEND: R/ \overline{W} = Read/Write; R = Read only; -n = value after reset

8.6.3 Bus Voltage Register (02h) (Read-Only)

The Bus Voltage Register stores the most recent bus voltage reading, VBUS.

If averaging is enabled, this register reports the averaged value.

Full-scale range = 40.96 V (decimal = 32767); LSB = 1.25 mV.

☒ **32. Bus Voltage Register (02h) (Read-Only)**

15 ⁽¹⁾	14	13	12	11	10	9	8
—	BD14	BD13	BD12	BD11	BD10	BD9	BD8
0	0	0	0	0	0	0	0
R							
7	6	5	4	3	2	1	0
BD7	BD6	BD5	BD4	BD3	BD2	BD1	BD0
0	0	0	0	0	0	0	0
R							

LEGEND: R/ \overline{W} = Read/Write; R = Read only; -n = value after reset

(1) Bit 15 is always zero because bus voltage can only be positive.

8.6.4 Power Register (03h) (Read-Only)

If averaging is enabled, this register reports the averaged value.

The Power Register LSB is fixed to 10 mW.

The Power Register records power in Watts by multiplying the decimal values of the Current Register with the decimal value of the Bus Voltage Register. Values stored in the power register will always be positive regardless of the direction of current flow. The maximum value that can be returned by the power register is A3D7h or 419.43 W.

☒ **33. Power Register (03h) (Read-Only)**

15	14	13	12	11	10	9	8
PD15	PD14	PD13	PD12	PD11	PD10	PD9	PD8
0	0	0	0	0	0	0	0
R							
7	6	5	4	3	2	1	0
PD7	PD6	PD5	PD4	PD3	PD2	PD1	PD0
0	0	0	0	0	0	0	0
R							

LEGEND: R/ \overline{W} = Read/Write; R = Read only; -n = value after reset

8.6.5 Mask/Enable Register (06h) (Read/Write)

The Mask/Enable Register selects the function that is enabled to control the ALERT pin as well as how that pin functions. If multiple functions are enabled, the highest significant bit position Alert Function (D15-D11) takes priority and responds to the Alert Limit Register.

图 34. Mask/Enable Register (06h) (Read/Write)

15	14	13	12	11	10	9	8
OCL	UCL	BOL	BUL	POL	CNVR	—	—
0	0	0	0	0	0	0	0
R/W						R	
7	6	5	4	3	2	1	0
—	—	—	AFF	CVRF	OVF	APOL	LEN
0	0	0	0	0	0	0	0
R						R/W	

LEGEND: R/W = Read/Write; R = Read only; -n = value after reset

表 6. Mask/Enable Register Field Descriptions

Bit	Field	Type	Reset	Description
15	OCL	R/W	0	Over Current Limit Setting this bit high configures the ALERT pin to be asserted if the current measurement following a conversion exceeds the value programmed in the Alert Limit Register.
14	UCL	R/W	0	Under Current Limit Setting this bit high configures the ALERT pin to be asserted if the current measurement following a conversion drops below the value programmed in the Alert Limit Register.
13	BOL	R/W	0	Bus Voltage Over-Voltage Setting this bit high configures the ALERT pin to be asserted if the bus voltage measurement following a conversion exceeds the value programmed in the Alert Limit Register.
12	BUL	R/W	0	Bus Voltage Under-Voltage Setting this bit high configures the ALERT pin to be asserted if the bus voltage measurement following a conversion drops below the value programmed in the Alert Limit Register.
11	POL	R/W	0	Power Over-Limit Setting this bit high configures the ALERT pin to be asserted if the Power calculation made following a bus voltage measurement exceeds the value programmed in the Alert Limit Register.
10	CNVR	R/W	0	Conversion Ready Setting this bit high configures the ALERT pin to be asserted when the Conversion Ready Flag, Bit 3, is asserted indicating that the device is ready for the next conversion.
9–5	—	R	00000	Not used.
4	AFF	R	0	Alert Function Flag While only one Alert Function can be monitored at the ALERT pin at a time, the Conversion Ready can also be enabled to assert the ALERT pin. Reading the Alert Function Flag following an alert allows the user to determine if the Alert Function was the source of the Alert. When the Alert Latch Enable bit is set to Latch mode, the Alert Function Flag bit clears only when the Mask/Enable Register is read. When the Alert Latch Enable bit is set to Transparent mode, the Alert Function Flag bit is cleared following the next conversion that does not result in an Alert condition.
3	CVRF	R	0	Conversion Ready Although the device can be read at any time, and the data from the last conversion is available, the Conversion Ready Flag bit is provided to help coordinate one-shot or triggered conversions. The Conversion Ready Flag bit is set after all conversions, averaging, and multiplications are complete. Conversion Ready Flag bit clears under the following conditions: 1.) Writing to the Configuration Register (except for Power-Down selection) 2.) Reading the Mask/Enable Register

表 6. Mask/Enable Register Field Descriptions (continued)

Bit	Field	Type	Reset	Description
2	OVF	R	0	Math Overflow Flag This bit is set to '1' if an arithmetic operation resulted in an overflow error. It indicates that power data may have exceeded the maximum reportable value of 419.43 W.
1	APOL	R \overline{W}	0	Alert Polarity bit 1 = Inverted (active-high open collector) 0 = Normal (active-low open collector) (default)
0	LEN	R \overline{W}	0	Alert Latch Enable; configures the latching feature of the ALERT pin and Alert Flag bits. 1 = Latch enabled 0 = Transparent (default) When the Alert Latch Enable bit is set to Transparent mode, the ALERT pin and Flag bit resets to the idle states when the fault has been cleared. When the Alert Latch Enable bit is set to Latch mode, the ALERT pin and Alert Flag bit remains active following a fault until the Mask/Enable Register has been read.

8.6.6 Alert Limit Register (07h) (Read/Write)

The Alert Limit Register contains the value used to compare to the register selected in the Mask/Enable Register to determine if a limit has been exceeded. The format for this register will match the format of the register that is selected for comparison.

图 35. Alert Limit Register (07h) (Read/Write)

15	14	13	12	11	10	9	8
AUL15	AUL14	AUL13	AUL12	AUL11	AUL10	AUL9	AUL8
0	0	0	0	0	0	0	0
R \overline{W}							
7	6	5	4	3	2	1	0
AUL7	AUL6	AUL5	AUL4	AUL3	AUL2	AUL1	AUL0
0	0	0	0	0	0	0	0
R \overline{W}							

LEGEND: R \overline{W} = Read/Write; R = Read only; -n = value after reset

8.6.7 Manufacturer ID Register (FEh) (Read-Only)

The Manufacturer ID Register stores a unique identification number for the manufacturer.

图 36. Manufacturer ID Register (FEh) (Read-Only)

15	14	13	12	11	10	9	8
ID15	ID14	ID13	ID12	ID11	ID10	ID9	ID8
0	1	0	1	0	1	0	0
R							
7	6	5	4	3	2	1	0
ID7	ID6	ID5	ID4	ID3	ID2	ID1	ID0
0	1	0	0	1	0	0	1
R							

LEGEND: R \overline{W} = Read/Write; R = Read only; -n = value after reset

表 7. Manufacturer ID Register Field Descriptions

Bit	Field	Type	Reset	Description
15–0	ID	R	5449h /TI (ascii)	Manufacturer ID Stores the manufacturer identification bits

8.6.8 Die ID Register (FFh) (Read-Only)

The Die ID Register stores a unique identification number and the revision ID for the die.

☒ 37. Die ID Register (FFh) (Read-Only)

15	14	13	12	11	10	9	8
DID11	DID10	DID9	DID8	DID7	DID6	DID5	DID4
0	0	1	0	0	0	1	0
R							
7	6	5	4	3	2	1	0
DID3	DID2	DID1	DID0	RID3	RID2	RID1	RID0
0	1	1	1	0	0	0	0
R							

LEGEND: R/ \overline{W} = Read/Write; R = Read only; -n = value after reset

表 8. Die ID Register Field Descriptions

Bit	Field	Type	Reset	Description
15–4	DID	R	227h	Device ID Stores the device identification bits.
3–0	RID	R	0h	Die Revision ID Stores the device revision identification bits.

9 Application and Implementation

注

Information in the following applications sections is not part of the TI component specification, and TI does not warrant its accuracy or completeness. TI's customers are responsible for determining suitability of components for their purposes. Validate and test the design implementation to confirm system functionality.

9.1 Application Information

The INA260 is a current shunt and power monitor with an I²C-compatible interface. The device monitors both a shunt current and bus supply voltage. The internally calibrated integrated current sense resistor combined with an internal multiplier, enable direct readouts of current in amperes and power in watts.

9.2 Typical Application



图 38. Typical Circuit Configuration, INA260

9.2.1 Design Requirements

The INA260 measures current and the bus supply voltage and calculates power. It comes with alert capability where the ALERT pin can be programmed to respond to a user-defined event or to a conversion ready notification. This design illustrates the ability of the ALERT pin to respond to a set threshold.

Typical Application (continued)

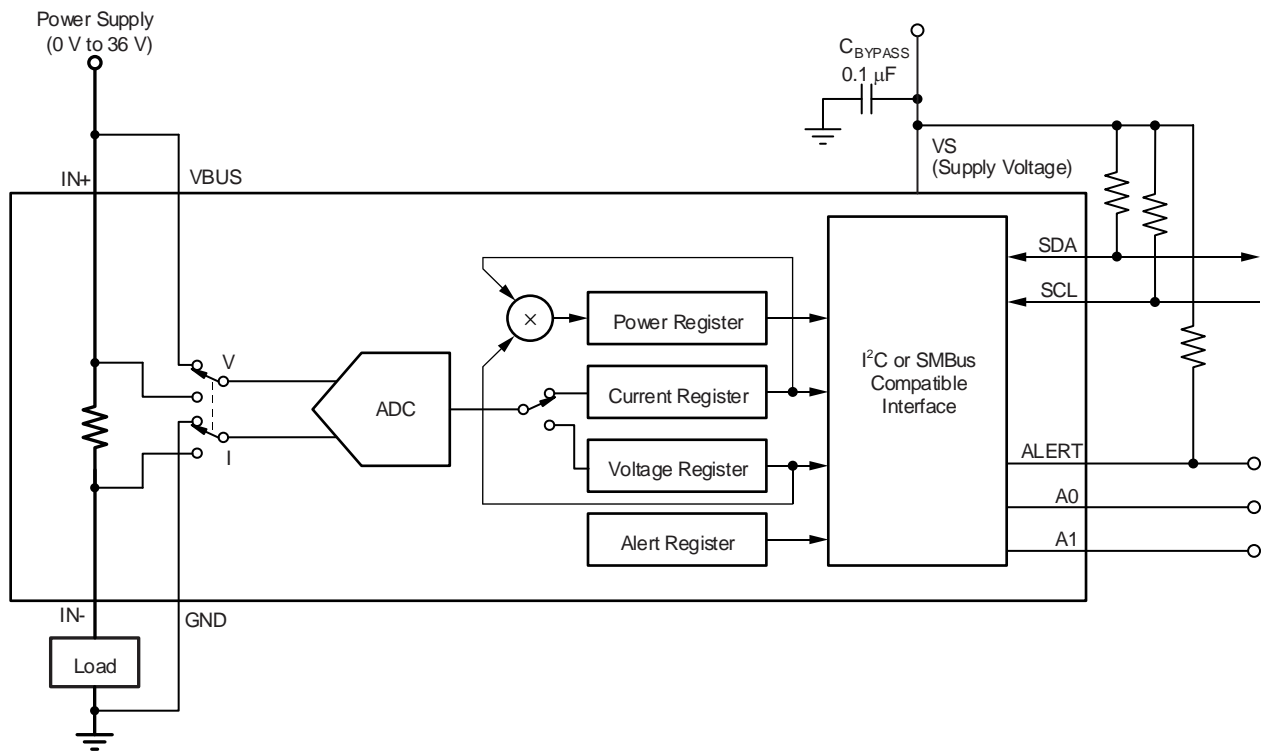
9.2.2 Detailed Design Procedure

The ALERT pin can be configured to respond to one of the five alert functions described in the [ALERT Pin](#) section. The ALERT pin must be pulled up to the VS pin voltage through an external pullup resistor. The configuration register is set based on the required conversion time and averaging. The Mask/Enable Register is set to identify the required alert function and the Alert Limit Register is set to the limit value used for comparison.

9.2.3 Application Curves

Figure 40 shows the ALERT pin response to a bus over voltage limit of 5.5 V for a conversion time (t_{CT}) of 1.1 ms and averaging set to 1. Figure 39 shows the response for the same limit but with the conversion time reduced to 140 μ s. For the scope shots shown in these figures, persistence was enabled on the ALERT channel. This shows how the ALERT response time can vary depending on when the fault condition occurs relative to the internal ADC clock of the INA260. For fault conditions that are just exceeding the limit threshold the response time for the ALERT pin can vary from 1 to 2 conversion cycles. As mentioned, the variation is due to the timing on when the fault event occurs relative to the start time of the internal ADC conversion cycle. For fault events that greatly exceed the limit threshold it is possible for the alert to respond in less than one conversion cycle. This is because it takes fewer samples for the average to exceed the limit threshold value.



表 9. Configuration Register (00h) Settings for Figure 39 (Value = 6006h)

BIT #	15	14	13	12	11	10	9	8	7	6	5	4	3	2	1	0
BIT NAME	RST	—	—	—	AVG2	AVG1	AVG0	VBUSC T2	VBUSC T1	VBUSC T0	ISHCT2	ISHCT1	ISHCT0	MODE3	MODE2	MODE1
POR VALUE	0	1	1	0	0	0	0	0	0	0	0	0	0	1	1	0

表 10. Configuration Register (00h) Settings for Figure 40 (Value = 6126h)

BIT #	15	14	13	12	11	10	9	8	7	6	5	4	3	2	1	0
BIT NAME	RST	—	—	—	AVG2	AVG1	AVG0	VBUSC T2	VBUSC T1	VBUSC T0	ISHCT2	ISHCT1	ISHCT0	MODE3	MODE2	MODE1
POR VALUE	0	1	1	0	0	0	0	1	0	0	1	0	0	1	1	0

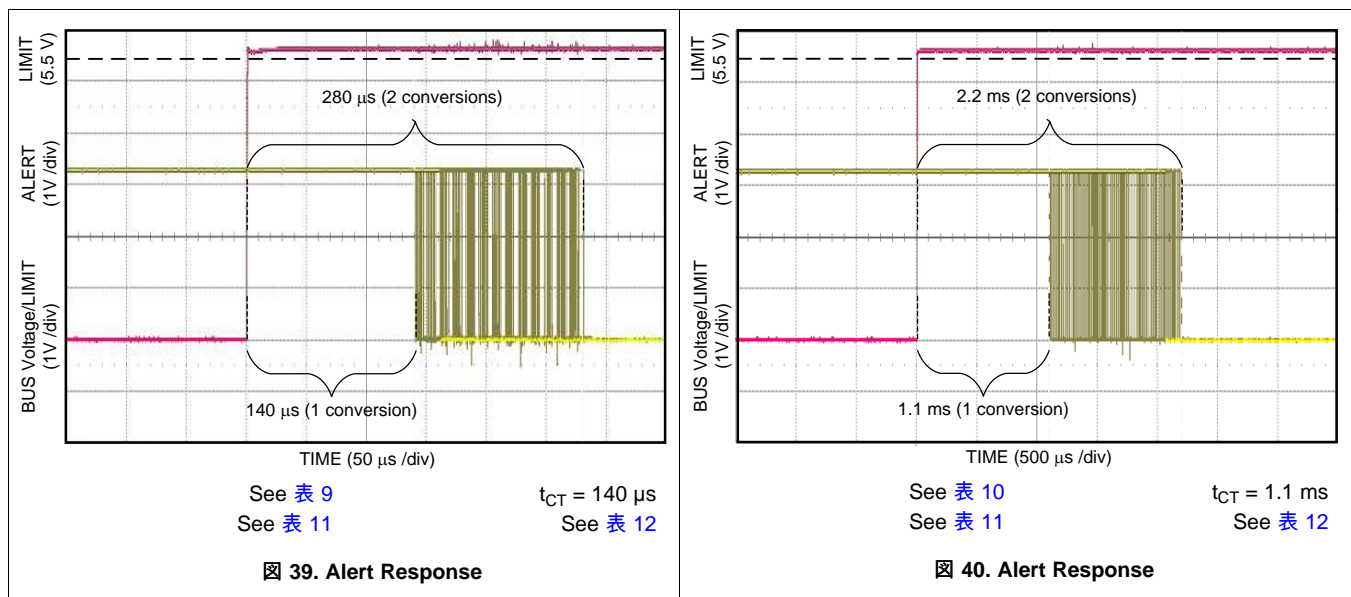
表 11. Mask/Enable Register (06h) Settings for Figure 39 and Figure 40 (Value = 2008h)

BIT #	15	14	13	12	11	10	9	8	7	6	5	4	3	2	1	0
BIT NAME	OCL	UCL	BOL	BUL	POL	CNVR	—	—	—	—	—	AFF	CVRF	OVF	APOL	LEN
POR VALUE	0	0	1	0	0	0	0	0	0	0	0	0	1	0	0	0

表 12. Alert Limit Register (07h) Settings for **☒ 39** and **☒ 40** (Value = 1130h)

BIT #	15	14	13	12	11	10	9	8	7	6	5	4	3	2	1	0
BIT NAME	AUL15	AUL14	AUL13	AUL12	AUL11	AUL10	AUL9	AUL8	AUL7	AUL6	AUL5	AUL4	AUL3	AUL2	AUL1	AUL0
POR VALUE	0	0	0	1	0	0	0	1	0	0	1	1	0	0	0	0

10 Power Supply Recommendations

The input circuitry of the device can accurately measure signals on common-mode voltages beyond its power supply voltage, V_{VS} . For example, the voltage applied to the power supply terminal (VS) can be 5 V, whereas the load power-supply voltage being monitored (the common-mode voltage) can be as high as 36 V. Note also that the device can withstand the full 0-V to 36-V range at the input terminals, regardless of whether the device has power applied or not.

Place the required power-supply bypass capacitors as close as possible to the supply and ground terminals of the device. A typical value for this supply bypass capacitor is 0.1 μ F. Applications with noisy or high-impedance power supplies may require additional decoupling capacitors to reject power-supply noise.

11 Layout

11.1 Layout Guidelines

Connections to the internal shunt resistor should be connected directly into and out of the shunt resistor pins to encourage uniform current flow through the device. The trace width should be sized correctly to handle the desired current flow. Place the power-supply bypass capacitor as close as possible to the supply and ground pins. Use of multiple vias to connect the device ground to the bypass capacitor grounds is recommended if there is not direct connection on the top layer.

11.2 Layout Example

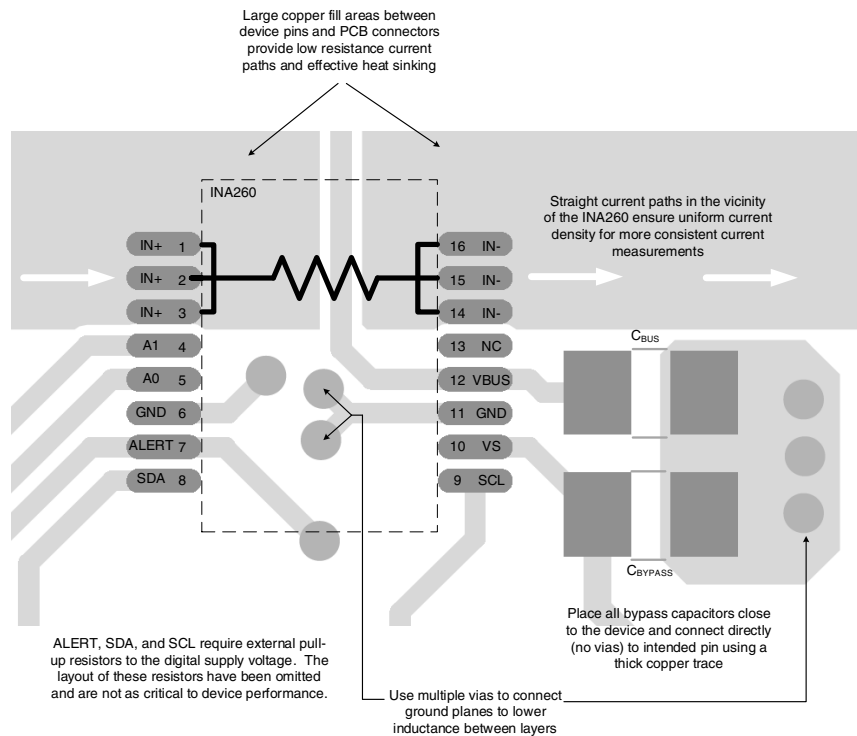

NOTE: Connect the VBUS pin to the power supply rail.

☒ 41. INA260 Layout Example

12 デバイスおよびドキュメントのサポート

12.1 デバイス・サポート

12.1.1 デベロッパー・ネットワークの製品に関する免責事項

デベロッパー・ネットワークの製品またはサービスに関するTIの出版物は、単独またはTIの製品、サービスと一緒に提供される場合に関係なく、デベロッパー・ネットワークの製品またはサービスの適合性に関する是認、デベロッパー・ネットワークの製品またはサービスの是認の表明を意味するものではありません。

12.2 ドキュメントのサポート

12.2.1 関連資料

関連資料については、以下を参照してください。

『[INA260EVM評価ボードおよびソフトウェア・チュートリアル・ユーザー・ガイド](#)』(SBOU113)

12.3 ドキュメントの更新通知を受け取る方法

ドキュメントの更新についての通知を受け取るには、ti.comのデバイス製品フォルダを開いてください。右上の隅にある「通知を受け取る」をクリックして登録すると、変更されたすべての製品情報に関するダイジェストを毎週受け取れます。変更の詳細については、修正されたドキュメントに含まれている改訂履歴をご覧ください。

12.4 コミュニティ・リソース

The following links connect to TI community resources. Linked contents are provided "AS IS" by the respective contributors. They do not constitute TI specifications and do not necessarily reflect TI's views; see TI's [Terms of Use](#).

TI E2E™オンライン・コミュニティ *TIのE2E (Engineer-to-Engineer)* コミュニティ。エンジニア間の共同作業を促進するために開設されたものです。e2e.ti.comでは、他のエンジニアに質問し、知識を共有し、アイデアを検討して、問題解決に役立てることができます。

設計サポート *TIの設計サポート* 役に立つE2Eフォーラムや、設計サポート・ツールをすばやく見つけることができます。技術サポート用の連絡先情報も参照できます。

12.5 商標

E2E is a trademark of Texas Instruments.

SMBus is a trademark of Intel Corporation.

All other trademarks are the property of their respective owners.

12.6 静電気放電に関する注意事項



すべての集積回路は、適切なESD保護方法を用いて、取扱いと保存を行うようにして下さい。

静電気放電はわずかな性能の低下から完全なデバイスの故障に至るまで、様々な損傷を与えます。高精度の集積回路は、損傷に対して敏感であり、極めてわずかなパラメータの変化により、デバイスに規定された仕様に適合しなくなる場合があります。

12.7 用語集

SLYZ022 — *TI用語集*.

この用語集には、用語や略語の一覧および定義が記載されています。

13 メカニカル、パッケージ、および注文情報

以降のページには、メカニカル、パッケージ、および注文に関する情報が記載されています。この情報は、そのデバイスについて利用可能な最新のデータです。このデータは予告なく変更されることがあり、ドキュメントが改訂される場合もあります。本データシートのブラウザ版を使用されている場合は、画面左側の説明をご覧ください。

PACKAGING INFORMATION

Orderable part number	Status (1)	Material type (2)	Package Pins	Package qty Carrier	RoHS (3)	Lead finish/ Ball material (4)	MSL rating/ Peak reflow (5)	Op temp (°C)	Part marking (6)
INA260AIPWR	Active	Production	TSSOP (PW) 16	2000 LARGE T&R	Yes	NIPDAU	Level-2-260C-1 YEAR	-40 to 125	I260AI
INA260AIPWR.B	Active	Production	TSSOP (PW) 16	2000 LARGE T&R	Yes	NIPDAU	Level-2-260C-1 YEAR	-40 to 125	I260AI
INA260AIPWRG4	Active	Production	TSSOP (PW) 16	2000 LARGE T&R	Yes	NIPDAU	Level-2-260C-1 YEAR	-40 to 125	I260AI
INA260AIPWRG4.B	Active	Production	TSSOP (PW) 16	2000 LARGE T&R	Yes	NIPDAU	Level-2-260C-1 YEAR	-40 to 125	I260AI

(1) **Status:** For more details on status, see our [product life cycle](#).

(2) **Material type:** When designated, preproduction parts are prototypes/experimental devices, and are not yet approved or released for full production. Testing and final process, including without limitation quality assurance, reliability performance testing, and/or process qualification, may not yet be complete, and this item is subject to further changes or possible discontinuation. If available for ordering, purchases will be subject to an additional waiver at checkout, and are intended for early internal evaluation purposes only. These items are sold without warranties of any kind.

(3) **RoHS values:** Yes, No, RoHS Exempt. See the [TI RoHS Statement](#) for additional information and value definition.

(4) **Lead finish/Ball material:** Parts may have multiple material finish options. Finish options are separated by a vertical ruled line. Lead finish/Ball material values may wrap to two lines if the finish value exceeds the maximum column width.

(5) **MSL rating/Peak reflow:** The moisture sensitivity level ratings and peak solder (reflow) temperatures. In the event that a part has multiple moisture sensitivity ratings, only the lowest level per JEDEC standards is shown. Refer to the shipping label for the actual reflow temperature that will be used to mount the part to the printed circuit board.

(6) **Part marking:** There may be an additional marking, which relates to the logo, the lot trace code information, or the environmental category of the part.

Multiple part markings will be inside parentheses. Only one part marking contained in parentheses and separated by a "~" will appear on a part. If a line is indented then it is a continuation of the previous line and the two combined represent the entire part marking for that device.

Important Information and Disclaimer: The information provided on this page represents TI's knowledge and belief as of the date that it is provided. TI bases its knowledge and belief on information provided by third parties, and makes no representation or warranty as to the accuracy of such information. Efforts are underway to better integrate information from third parties. TI has taken and continues to take reasonable steps to provide representative and accurate information but may not have conducted destructive testing or chemical analysis on incoming materials and chemicals. TI and TI suppliers consider certain information to be proprietary, and thus CAS numbers and other limited information may not be available for release.

In no event shall TI's liability arising out of such information exceed the total purchase price of the TI part(s) at issue in this document sold by TI to Customer on an annual basis.

TAPE AND REEL INFORMATION

QUADRANT ASSIGNMENTS FOR PIN 1 ORIENTATION IN TAPE



*All dimensions are nominal

Device	Package Type	Package Drawing	Pins	SPQ	Reel Diameter (mm)	Reel Width W1 (mm)	A0 (mm)	B0 (mm)	K0 (mm)	P1 (mm)	W (mm)	Pin1 Quadrant
INA260AIPWR	TSSOP	PW	16	2000	330.0	12.4	6.9	5.6	1.6	8.0	12.0	Q1
INA260AIPWRG4	TSSOP	PW	16	2000	330.0	12.4	6.9	5.6	1.6	8.0	12.0	Q1

TAPE AND REEL BOX DIMENSIONS

*All dimensions are nominal

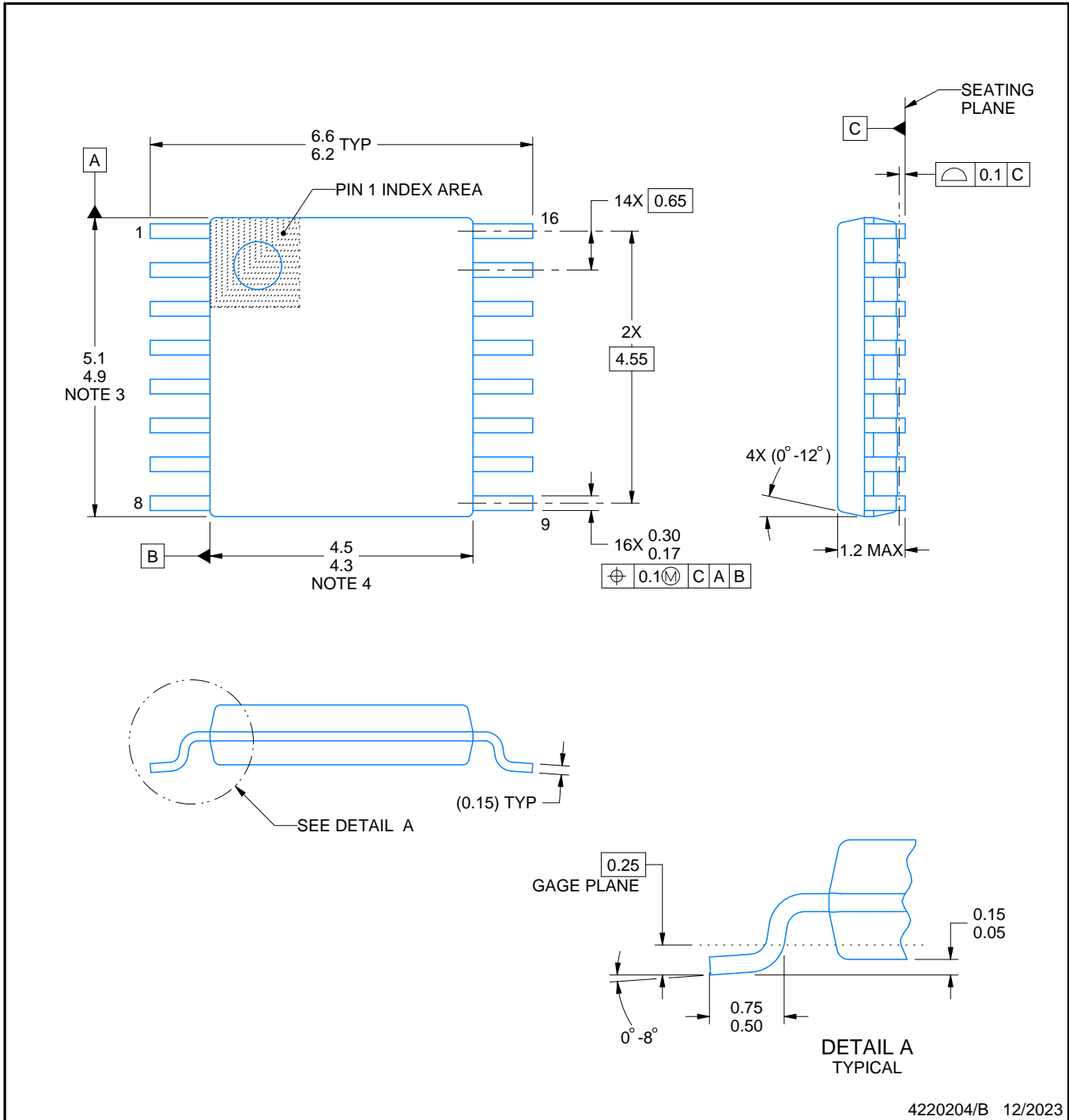
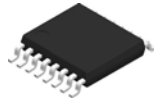
Device	Package Type	Package Drawing	Pins	SPQ	Length (mm)	Width (mm)	Height (mm)
INA260AIPWR	TSSOP	PW	16	2000	353.0	353.0	32.0
INA260AIPWRG4	TSSOP	PW	16	2000	353.0	353.0	32.0



4220204/B 12/2023

NOTES:

1. All linear dimensions are in millimeters. Any dimensions in parenthesis are for reference only. Dimensioning and tolerancing per ASME Y14.5M.
2. This drawing is subject to change without notice.
3. This dimension does not include mold flash, protrusions, or gate burrs. Mold flash, protrusions, or gate burrs shall not exceed 0.15 mm per side.
4. This dimension does not include interlead flash. Interlead flash shall not exceed 0.25 mm per side.
5. Reference JEDEC registration MO-153.

EXAMPLE BOARD LAYOUT

PW0016A

TSSOP - 1.2 mm max height

SMALL OUTLINE PACKAGE

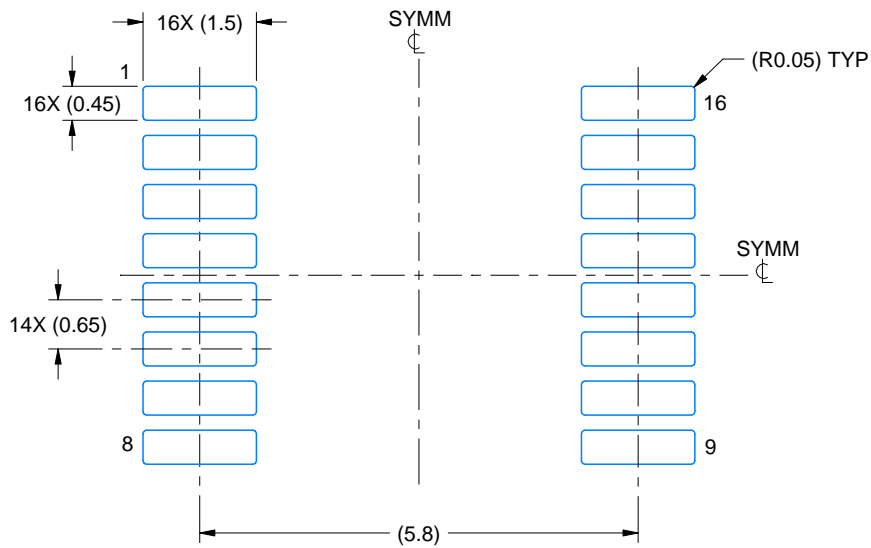

LAND PATTERN EXAMPLE
EXPOSED METAL SHOWN
SCALE: 10X

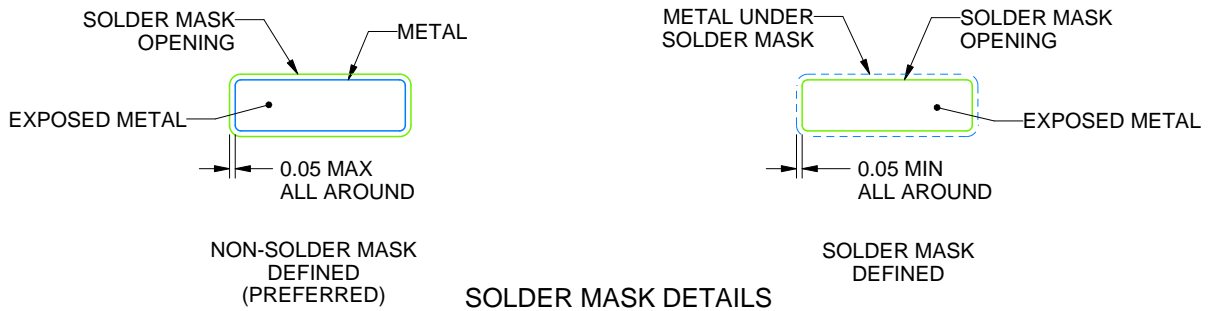

SOLDER MASK DETAILS

4220204/B 12/2023

NOTES: (continued)

- 6. Publication IPC-7351 may have alternate designs.
- 7. Solder mask tolerances between and around signal pads can vary based on board fabrication site.

EXAMPLE STENCIL DESIGN

PW0016A

TSSOP - 1.2 mm max height

SMALL OUTLINE PACKAGE

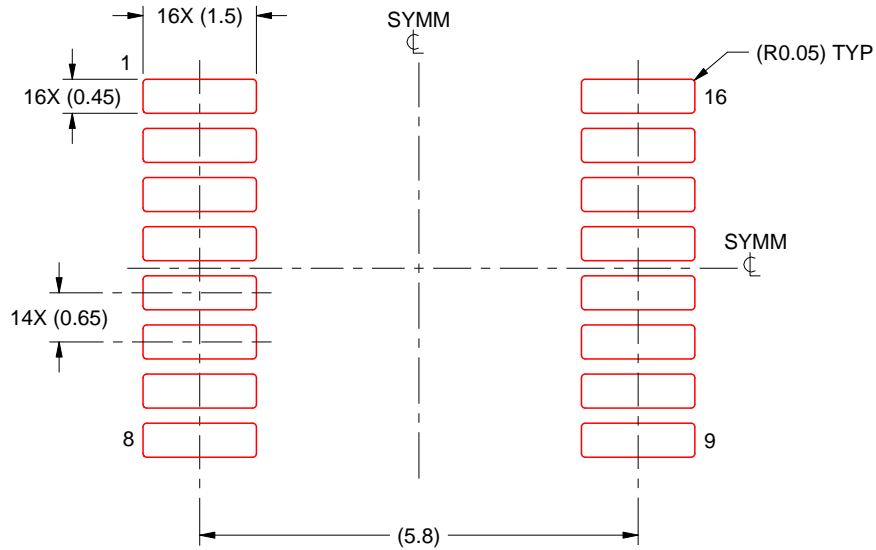

SOLDER PASTE EXAMPLE
BASED ON 0.125 mm THICK STENCIL
SCALE: 10X

4220204/B 12/2023

NOTES: (continued)

8. Laser cutting apertures with trapezoidal walls and rounded corners may offer better paste release. IPC-7525 may have alternate design recommendations.
9. Board assembly site may have different recommendations for stencil design.

重要なお知らせと免責事項

TI は、技術データと信頼性データ (データシートを含みます)、設計リソース (リファレンス デザインを含みます)、アプリケーションや設計に関する各種アドバイス、Web ツール、安全性情報、その他のリソースを、欠陥が存在する可能性のある「現状のまま」提供しており、商品性および特定目的に対する適合性の黙示保証、第三者の知的財産権の非侵害保証を含むいかなる保証も、明示的または黙示的にかかわらず拒否します。

これらのリソースは、TI 製品を使用する設計の経験を積んだ開発者への提供を意図したものです。(1) お客様のアプリケーションに適した TI 製品の選定、(2) お客様のアプリケーションの設計、検証、試験、(3) お客様のアプリケーションに該当する各種規格や、その他のあらゆる安全性、セキュリティ、規制、または他の要件への確実な適合に関する責任を、お客様のみが単独で負うものとし、

上記の各種リソースは、予告なく変更される可能性があります。これらのリソースは、リソースで説明されている TI 製品を使用するアプリケーションの開発の目的でのみ、TI はその使用をお客様に許諾します。これらのリソースに関して、他の目的で複製することや掲載することは禁止されています。TI や第三者の知的財産権のライセンスが付与されている訳ではありません。お客様は、これらのリソースを自身で使用した結果発生するあらゆる申し立て、損害、費用、損失、責任について、TI およびその代理人を完全に補償するものとし、TI は一切の責任を拒否します。

TI の製品は、[TI の販売条件](#)、[TI の総合的な品質ガイドライン](#)、[ti.com](#) または TI 製品などに関連して提供される他の適用条件に従い提供されます。TI がこれらのリソースを提供することは、適用される TI の保証または他の保証の放棄の拡大や変更を意味するものではありません。TI がカスタム、またはカスタマー仕様として明示的に指定していない限り、TI の製品は標準的なカタログに掲載される汎用機器です。

お客様がいかなる追加条項または代替条項を提案する場合も、TI はそれらに異議を唱え、拒否します。

Copyright © 2026, Texas Instruments Incorporated

最終更新日 : 2025 年 10 月