

ISO672x 汎用、基本絶縁、デュアルチャネル・デジタル・アイソレータ、堅 牢な EMC

1 特長

- 機能安全対応
 - 機能安全システムの設計に役立つ資料を利用可能 [ISO6720](#)、[ISO6721](#)
- 50Mbps のデータ・レート
- 堅牢な絶縁バリア
 - 450V_{RMS} の使用電圧での長い寿命
 - 最高 3000V_{RMS} の絶縁定格
 - CMTI: ±150kV/μs (標準値)
- 広い電源電圧範囲: 1.71V~1.89V、2.25V~5.5V
- 1.71V から 5.5V への電圧変換
- デフォルト出力 HIGH (ISO672xB) および LOW (ISO672xFB) のオプション
- 広い温度範囲: -40°C~+125°C
- チャネルごとに 1.8mA (標準値、1Mbps の場合)
- 小さい伝搬遅延時間: 11ns (標準値)
- 堅牢な電磁気互換性 (EMC)
 - システム・レベルでの ESD、EFT、サージ耐性
 - 絶縁バリアの両側で ±8kV の IEC 61000-4-2 接触放電保護
 - 低い放射
- ナロー SOIC (D-8) パッケージ
- 安全関連の認証:
 - DIN EN IEC 60747-17 (VDE 0884-17)
 - UL 1577 部品認定プログラム
 - IEC 62368-1、IEC 61010-1、IEC 60601-1
 - GB 4943.1

2 アプリケーション

- 電源
- 電力網、電力量計
- モータ・ドライブ
- ファクトリ・オートメーション
- ビル・オートメーション
- ライティング
- 家電製品

3 概要

ISO672xB デバイスは、最大 3000V_{RMS} (D パッケージ) の UL 1577 絶縁定格を必要とする、コストの制約が厳しいアプリケーションに理想的な高性能デュアルチャネル・デジタル・アイソレータです。これらのデバイスは VDE、TUV、CSA、CQC の認定も受けています。

ISO672xB デバイスは、CMOS または LVCMOS デジタル I/O を絶縁しながら、低消費電力で高い電磁気耐性と

低い放射を実現します。各絶縁チャネルは、テキサス・インスツルメンツの二重容量性二酸化ケイ素 (SiO₂) 絶縁バリアで分離されたロジック入力および出力バッファを備えています。ISO6720B デバイスは 2 つの絶縁チャネルを備えており、どちらのチャネルも同一方向です。ISO6721B デバイスは 2 つの絶縁チャネルを備えており、各チャネルは別方向です。入力電力または入力信号が失われた場合のデフォルト出力は、接尾辞 F のないデバイスでは HIGH、接尾辞 F のあるデバイスでは LOW です。詳細は「[デバイスの機能モード](#)」のセクションを参照してください。

これらのデバイスを絶縁電源と組み合わせて使用することで、UART、SPI、RS-485、RS-232、CAN などのデータバスのノイズ電流によって敏感な回路が損傷を受けることを防止できます。革新的なチップ設計およびレイアウト技法により、ISO672xB は電磁両立性が大幅に強化されているため、システム・レベルの ESD、EFT、サージ、および放射のコンプライアンスを容易に達成できます。ISO672xB デバイス・ファミリーは、8 ピン SOIC ナロー・ボディ (D) パッケージで供給され、旧世代品に対してピン互換です。強化絶縁の要件については、[ISO672x-Q1](#) を参照してください。

デバイス情報

部品番号 ⁽¹⁾	パッケージ	本体サイズ (公称)
ISO6720B、ISO6720FB	D (8)	4.90mm × 3.91mm
ISO6721B、ISO6721FB		
ISO6721RB、ISO6721RFB		

- (1) 利用可能なパッケージについては、このデータシートの末尾にある注文情報を参照してください。

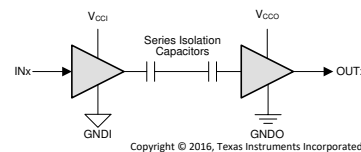

V_{CCI} = 入力電源、V_{CCO} = 出力電源

GNDI = 入力グラウンド、GND0 = 出力グラウンド

概略回路図



Table of Contents

1 特長.....	1	6.21 Insulation Characteristics Curves.....	22
2 アプリケーション.....	1	6.22 Typical Characteristics.....	23
3 概要.....	1	7 Parameter Measurement Information.....	25
4 Revision History.....	2	8 Detailed Description.....	26
5 Pin Configuration and Functions.....	4	8.1 Overview.....	26
6 Specifications.....	5	8.2 Functional Block Diagram.....	26
6.1 Absolute Maximum Ratings.....	5	8.3 Feature Description.....	27
6.2 ESD Ratings.....	5	8.4 Device Functional Modes.....	28
6.3 Recommended Operating Conditions.....	6	9 Application and Implementation.....	29
6.4 Thermal Information.....	7	9.1 Application Information.....	29
6.5 Power Ratings.....	7	9.2 Typical Application.....	30
6.6 Insulation Specifications.....	8	9.3 <i>Insulation Lifetime</i>	32
6.7 Safety-Related Certifications.....	10	10 Power Supply Recommendations.....	34
6.8 Safety Limiting Values.....	10	11 Layout.....	35
6.9 Electrical Characteristics—5-V Supply.....	12	11.1 Layout Guidelines.....	35
6.10 Supply Current Characteristics—5-V Supply.....	12	11.2 Layout Example.....	36
6.11 Electrical Characteristics—3.3-V Supply.....	14	12 Device and Documentation Support.....	37
6.12 Supply Current Characteristics—3.3-V Supply.....	14	12.1 Device Support.....	37
6.13 Electrical Characteristics—2.5-V Supply.....	16	12.2 Documentation Support.....	37
6.14 Supply Current Characteristics—2.5-V Supply.....	16	12.3 Receiving Notification of Documentation Updates.....	37
6.15 Electrical Characteristics—1.8-V Supply.....	18	12.4 サポート・リソース.....	37
6.16 Supply Current Characteristics—1.8-V Supply.....	18	12.5 Trademarks.....	37
6.17 Switching Characteristics—5-V Supply.....	20	12.6 静電気放電に関する注意事項.....	37
6.18 Switching Characteristics—3.3-V Supply.....	20	12.7 用語集.....	37
6.19 Switching Characteristics—2.5-V Supply.....	21	13 Mechanical, Packaging, and Orderable Information.....	37
6.20 Switching Characteristics—1.8-V Supply.....	21		

4 Revision History

資料番号末尾の英字は改訂を表しています。その改訂履歴は英語版に準じています。

Changes from Revision E (May 2022) to Revision F (February 2023)	Page
ドキュメント全体を通して標準名を以下のように変更:「DIN V VDE V 0884-11:2017-01」から「DIN EN IEC 60747-17 (VDE 0884-17)」.....	1
ドキュメント全体を通して、IEC/EN/CSA 60950-1 規格への参照を削除.....	1
ドキュメント全体を通して「計画中」とマークされた標準を更新し、認証番号を記載.....	1
ドキュメント全体を通して、すべての標準名から標準リビジョンおよび年への参照を削除.....	1
Added Maximum impulse voltage (V_{IMP}) specification per DIN EN IEC 60747-17 (VDE 0884-17).....	8
Changed test conditions and values of Maximum surge isolation voltage (V_{IOSM}) specification per DIN EN IEC 60747-17 (VDE 0884-17).....	8
Clarified method b test conditions of Apparent charge (q_{PD}).....	8
Changed Maximum surge isolation voltage (V_{IOSM}) from 5000 V_{PK} to 6500 V_{PK}	10
Changed working voltage lifetime margin from 30% to 20% and minimum required insulation lifetime from 26 years to 24 years.....	32
Changed  9-8 per DIN EN IEC 60747-17 (VDE 0884-17).....	32

Changes from Revision D (September 2021) to Revision E (May 2022)	Page
Updated CMTI typical to 150 kV/us and minimum to 100 kV/us.....	5
Switched the labels for V_{CC1} falling and V_{CC2} rising in the graph legend of <i>Power Supply Undervoltage Threshold vs Free-Air Temperature</i>	23

Changes from Revision C (May 2021) to Revision D (September 2021) Page

- ISO6721RB デバイスをデータシートに追加..... **1**
-

Changes from Revision B (March 2021) to Revision C (May 2021) Page

- Updated CISPR 22 to CISPR 32..... **27**
 - Updated *Insulation Lifetime Projection Data* image..... **32**
 - Updated *Power Supply Recommendations* document references..... **34**
 - Added the *Device Support* section..... **37**
-

Changes from Revision A (December 2020) to Revision B (March 2021) Page

- Switched the line colors for V_{CC} at 2.5 V and V_{CC} at 3.3 V in **23**
 - Switched the labels for V_{CC1} falling and V_{CC2} rising in the graph legend of *Power Supply Undervoltage Threshold vs Free-Air Temperature* **23**
-

Changes from Revision * (July 2020) to Revision A (December 2020) Page

- デバイスのステータスを「量産データ」に変更..... **1**
-

5 Pin Configuration and Functions



图 5-1. ISO6720B D Package 8-Pin SOIC Top View



图 5-2. ISO6721B D Package 8-Pin SOIC Top View

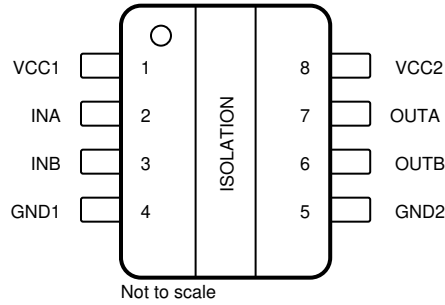

图 5-3. ISO6721RB D Package 8-Pin SOIC Top View

表 5-1. Pin Functions

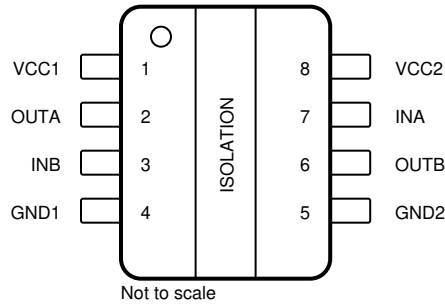
NAME	PIN			I/O	DESCRIPTION
	D PACKAGE				
	ISO6720B	ISO6721B	ISO6721RB		
GND1	4	4	4	—	Ground connection for V_{CC1}
GND2	5	5	5	—	Ground connection for V_{CC2}
INA	2	7	2	I	Input, channel A
INB	3	3	6	I	Input, channel B
OUTA	7	2	7	O	Output, channel A
OUTB	6	6	3	O	Output, channel B
V_{CC1}	1	1	1	—	Power supply, V_{CC1}
V_{CC2}	8	8	8	—	Power supply, V_{CC2}

6 Specifications

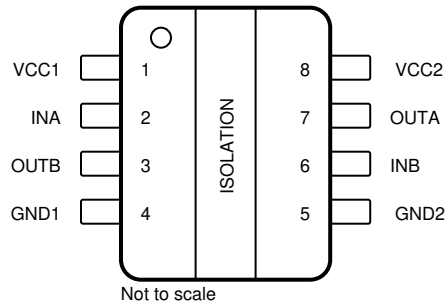
6.1 Absolute Maximum Ratings

See⁽¹⁾

		MIN	MAX	UNIT
Supply Voltage ⁽²⁾	V _{CC1} to GND1	-0.5	6	V
	V _{CC2} to GND2	-0.5	6	
Input/Output Voltage	IN _x to GND _x	-0.5	V _{CCX} + 0.5 ⁽³⁾	V
	OUT _x to GND _x	-0.5	V _{CCX} + 0.5 ⁽³⁾	
Output Current	I _o	-15	15	mA
Temperature	Operating junction temperature, T _J		150	°C
	Storage temperature, T _{stg}	-65	150	°C

- (1) Stresses beyond those listed under Absolute Maximum Ratings may cause permanent damage to the device. These are stress ratings only, which do not imply functional operation of the device at these or any other conditions beyond those indicated under Recommended Operating Conditions. Exposure to absolute-maximum-rated conditions for extended periods may affect device reliability.
- (2) All voltage values except differential I/O bus voltages are with respect to the local ground terminal (GND1 or GND2) and are peak voltage values
- (3) Maximum voltage must not exceed 6 V.

6.2 ESD Ratings

			VALUE	UNIT
V _(ESD)	Electrostatic discharge	Human body model (HBM), per ANSI/ESDA/JEDEC JS-001, all pins ⁽¹⁾	±6000	V
		Charged device model (CDM), per JEDEC specification JESD22-C101, all pins ⁽²⁾	±1500	
		Contact discharge per IEC 61000-4-2; Isolation barrier withstand test ^{(3) (4)}	±8000	

- (1) JEDEC document JEP155 states that 500-V HBM allows safe manufacturing with a standard ESD control process.
- (2) JEDEC document JEP157 states that 250-V CDM allows safe manufacturing with a standard ESD control process.
- (3) IEC ESD strike is applied across the barrier with all pins on each side tied together creating a two-terminal device.
- (4) Testing is carried out in air or oil to determine the intrinsic contact discharge capability of the device.

6.3 Recommended Operating Conditions

			MIN	NOM	MAX	UNIT
V_{CC1} ⁽¹⁾	Supply Voltage Side 1	$V_{CC} = 1.8\text{ V}$ ⁽³⁾	1.71		1.89	V
V_{CC1} ⁽¹⁾	Supply Voltage Side 1	$V_{CC} = 2.5\text{ V to }5\text{ V}$ ⁽³⁾	2.25		5.5	V
V_{CC2} ⁽¹⁾	Supply Voltage Side 2	$V_{CC} = 1.8\text{ V}$ ⁽³⁾	1.71		1.89	V
V_{CC2} ⁽¹⁾	Supply Voltage Side 2	$V_{CC} = 2.5\text{ V to }5\text{ V}$ ⁽³⁾	2.25		5.5	V
V_{CC} (UVLO+)	UVLO threshold when supply voltage is rising			1.53	1.71	V
V_{CC} (UVLO-)	UVLO threshold when supply voltage is falling		1.1	1.41		V
V_{hys} (UVLO)	Supply voltage UVLO hysteresis		0.08	0.13		V
V_{IH}	High level Input voltage		$0.7 \times V_{CCI}$ ⁽²⁾		V_{CCI}	V
V_{IL}	Low level Input voltage		0	$0.3 \times V_{CCI}$		V
I_{OH}	High level output current	V_{CCO} ⁽²⁾ = 5 V	-4			mA
		$V_{CCO} = 3.3\text{ V}$	-2			mA
		$V_{CCO} = 2.5\text{ V}$	-1			mA
		$V_{CCO} = 1.8\text{ V}$	-1			mA
I_{OL}	Low level output current	$V_{CCO} = 5\text{ V}$			4	mA
		$V_{CCO} = 3.3\text{ V}$			2	mA
		$V_{CCO} = 2.5\text{ V}$			1	mA
		$V_{CCO} = 1.8\text{ V}$			1	mA
DR	Data Rate		0		50	Mbps
T_A	Ambient temperature		-40	25	125	°C

(1) V_{CC1} and V_{CC2} can be set independent of one another

(2) $V_{CCI} = \text{Input-side } V_{CC}$; $V_{CCO} = \text{Output-side } V_{CC}$

(3) The channel outputs are in undetermined state when $1.89\text{ V} < V_{CC1}$, $V_{CC2} < 2.25\text{ V}$ and $1.05\text{ V} < V_{CC1}$, $V_{CC2} < 1.71\text{ V}$

6.4 Thermal Information

THERMAL METRIC ⁽¹⁾		ISO672xB	ISO6721RB	UNIT
		D (SOIC)	D (SOIC)	
		8 PINS	8 PINS	
R _{θJA}	Junction-to-ambient thermal resistance	104.6	98.5	°C/W
R _{θJC(top)}	Junction-to-case (top) thermal resistance	48.9	33.8	°C/W
R _{θJB}	Junction-to-board thermal resistance	52.9	47	°C/W
ψ _{JT}	Junction-to-top characterization parameter	7.9	2.3	°C/W
ψ _{JB}	Junction-to-board characterization parameter	52.1	46.2	°C/W
R _{θJC(bot)}	Junction-to-case (bottom) thermal resistance	n/a	n/a	°C/W

(1) For more information about traditional and new thermal metrics, see the [Semiconductor and IC Package Thermal Metrics application report](#).

6.5 Power Ratings

PARAMETER		TEST CONDITIONS	MIN	TYP	MAX	UNIT
ISO6720B						
P _D	Maximum power dissipation (both sides)	V _{CC1} = V _{CC2} = 5.5 V, T _J = 150°C, C _L = 15 pF, Input a 25-MHz 50% duty cycle square wave			72	mW
P _{D1}	Maximum power dissipation (side-1)				20	mW
P _{D2}	Maximum power dissipation (side-2)				52	mW
ISO6721B						
P _D	Maximum power dissipation (both sides)	V _{CC1} = V _{CC2} = 5.5 V, T _J = 150°C, C _L = 15 pF, Input a 25-MHz 50% duty cycle square wave			73	mW
P _{D1}	Maximum power dissipation (side-1)				37	mW
P _{D2}	Maximum power dissipation (side-2)				37	mW
ISO6721RB						
P _D	Maximum power dissipation (both sides)	V _{CC1} = V _{CC2} = 5.5 V, T _J = 150°C, C _L = 15 pF, Input a 25-MHz 50% duty cycle square wave			86	mW
P _{D1}	Maximum power dissipation (side-1)				43	mW
P _{D2}	Maximum power dissipation (side-2)				43	mW

6.6 Insulation Specifications

PARAMETER		TEST CONDITIONS	VALUE	UNIT
			8-D	
IEC 60664-1				
CLR	External clearance ⁽¹⁾	Side 1 to side 2 distance through air	>4	mm
CPG	External creepage ⁽¹⁾	Side 1 to side 2 distance across package surface	>4	mm
DTI	Distance through the insulation	Minimum internal gap (internal clearance)	>17	μm
CTI	Comparative tracking index	IEC 60112; UL 746A	>400	V
	Material Group	According to IEC 60664-1	II	
	Overvoltage category	Rated mains voltage ≤ 150 V _{RMS}	I-IV	
		Rated mains voltage ≤ 300 V _{RMS}	I-III	
DIN EN IEC 60747-17 (VDE 0884-17)⁽²⁾				
V _{IORM}	Maximum repetitive peak isolation voltage	AC voltage (bipolar)	637	V _{PK}
V _{IOWM}	Maximum isolation working voltage	AC voltage (sine wave); time-dependent dielectric breakdown (TDDb) test. See 9-8	450	V _{RMS}
		DC voltage	637	V _{DC}
V _{IOTM}	Maximum transient isolation voltage	V _{TEST} = V _{IOTM} , t = 60 s (qualification); V _{TEST} = 1.2 × V _{IOTM} , t = 1 s (100% production)	4242	V _{PK}
V _{IMP}	Maximum impulse voltage ⁽³⁾	Tested in air, 1.2/50-μs waveform per IEC 62368-1	5000	V _{PK}
V _{IOSM}	Maximum surge isolation voltage ⁽⁴⁾	V _{IOSM} ≥ 1.3 × V _{IMP} ; Tested in oil (qualification test), 1.2/50-μs waveform per IEC 62368-1	6500	V _{PK}
q _{pd}	Apparent charge ⁽⁵⁾	Method a: After I/O safety test subgroup 2/3, V _{ini} = V _{IOTM} , t _{ini} = 60 s; V _{pd(m)} = 1.2 × V _{IORM} , t _m = 10 s	≤ 5	pC
		Method a: After environmental tests subgroup 1, V _{ini} = V _{IOTM} , t _{ini} = 60 s; V _{pd(m)} = 1.3 × V _{IORM} , t _m = 10 s	≤ 5	
		Method b: At routine test (100% production) and preconditioning (type test); V _{ini} = 1.2 × V _{IOTM} , t _{ini} = 1 s; V _{pd(m)} = 1.5 × V _{IORM} , t _m = 1 s (method b1) or V _{pd(m)} = V _{ini} , t _m = t _{ini} (method b2)	≤ 5	
C _{IO}	Barrier capacitance, input to output ⁽⁶⁾	V _{IO} = 0.4 × sin(2 πft), f = 1 MHz	~0.5	pF
R _{IO}	Insulation resistance, input to output ⁽⁶⁾	V _{IO} = 500 V, T _A = 25°C	> 10 ¹²	Ω
		V _{IO} = 500 V, 100°C ≤ T _A ≤ 125°C	> 10 ¹¹	
		V _{IO} = 500 V at T _S = 150°C	> 10 ⁹	
	Pollution degree		2	
	Climatic category		40/125/21	
UL 1577				
V _{ISO}	Withstand isolation voltage	V _{TEST} = V _{ISO} , t = 60 s (qualification); V _{TEST} = 1.2 × V _{ISO} , t = 1 s (100% production)	3000	V _{RMS}

- Creepage and clearance requirements should be applied according to the specific equipment isolation standards of an application. Care should be taken to maintain the creepage and clearance distance of a board design to ensure that the mounting pads of the isolator on the printed-circuit board do not reduce this distance. Creepage and clearance on a printed-circuit board become equal in certain cases. Techniques such as inserting grooves, ribs, or both on a printed circuit board are used to help increase these specifications.
- ISO672x is suitable for *basic electrical insulation* only within the safety ratings. Compliance with the safety ratings shall be ensured by means of suitable protective circuits.
- Testing is carried out in air to determine the surge immunity of the package.
- Testing is carried out in oil to determine the intrinsic surge immunity of the isolation barrier.
- Apparent charge is electrical discharge caused by a partial discharge (pd).

- (6) All pins on each side of the barrier tied together creating a two-pin device.

6.7 Safety-Related Certifications

VDE	CSA	UL	CQC	TUV
Certified according to DIN EN IEC 60747-17 (VDE 0884-17)	Certified according to IEC 62368-1, IEC 61010-1 and IEC 60601	Certified according to UL 1577 Component Recognition Program	Certified according to GB 4943.1	Certified according to EN 61010-1 and EN 62368-1
Maximum transient isolation voltage, 4242 V _{PK} ; Maximum repetitive peak isolation voltage, 637 V _{PK} ; Maximum surge isolation voltage, 6500 V _{PK}	400 V _{RMS} basic insulation per CSA 62368-1 and IEC 62368-1; 300 V _{RMS} basic insulation per CSA 61010-1 and IEC 61010-1 (pollution degree 2, material group III) 1 MOPP (Means of Patient Protection) per CSA 60601-1 and IEC 60601-1, 250 V _{RMS} (D-8) max working voltage	Single protection, 3000 V _{RMS}	Basic insulation, Altitude ≤ 5000 m, Tropical Climate, 250 V _{RMS} maximum working voltage	3000 V _{RMS} (D-8) Basic insulation per EN 61010-1 up to working voltage of 300 V _{RMS} (D-8) 3000 V _{RMS} (D-8) basic insulation per EN 62368-1 up to working voltage of 400 V _{RMS} (D-8)
Certificate number: 40047657	Master contract number: 220991	File number: E181974	Certificate number: CQC21001305151	Client ID number: 077311

6.8 Safety Limiting Values

Safety limiting⁽¹⁾ intends to minimize potential damage to the isolation barrier upon failure of input or output circuitry.

PARAMETER		TEST CONDITIONS	MIN	TYP	MAX	UNIT
D-8 PACKAGE - ISO672xB						
I _S	Safety input, output, or supply current ⁽¹⁾	R _{θJA} = 104.6°C/W, V _I = 5.5 V, T _J = 150°C, T _A = 25°C See 6-1			217.2	mA
		R _{θJA} = 104.6°C/W, V _I = 3.6 V, T _J = 150°C, T _A = 25°C See 6-1			332	mA
		R _{θJA} = 104.6°C/W, V _I = 2.75 V, T _J = 150°C, T _A = 25°C See 6-1			434.5	mA
		R _{θJA} = 104.6°C/W, V _I = 1.89 V, T _J = 150°C, T _A = 25°C See 6-1			628.9	mA
P _S	Safety input, output, or total power ⁽¹⁾	R _{θJA} = 104.6°C/W, T _J = 150°C, T _A = 25°C See 6-2			1195	mW
T _S	Maximum safety temperature ⁽¹⁾				150	°C

Safety limiting⁽¹⁾ intends to minimize potential damage to the isolation barrier upon failure of input or output circuitry.

PARAMETER		TEST CONDITIONS	MIN	TYP	MAX	UNIT
D-8 PACKAGE - ISO6721RB						
I _S	Safety input, output, or supply current ⁽¹⁾	R _{θJA} = 98.5°C/W, V _I = 5.5 V, T _J = 150°C, T _A = 25°C See 6-3			230.7	mA
		R _{θJA} = 98.5°C/W, V _I = 3.6 V, T _J = 150°C, T _A = 25°C See 6-3			352.5	mA
		R _{θJA} = 98.5°C/W, V _I = 2.75 V, T _J = 150°C, T _A = 25°C See 6-3			461.5	mA
		R _{θJA} = 98.5°C/W, V _I = 1.89 V, T _J = 150°C, T _A = 25°C See 6-3			671.4	mA
P _S	Safety input, output, or total power ⁽¹⁾	R _{θJA} = 98.5°C/W, T _J = 150°C, T _A = 25°C See 6-4			1269	mW
T _S	Maximum safety temperature ⁽¹⁾				150	°C

- (1) The maximum safety temperature, T_S, has the same value as the maximum junction temperature, T_J, specified for the device. The I_S and P_S parameters represent the safety current and safety power respectively. The maximum limits of I_S and P_S should not be exceeded. These limits vary with the ambient temperature, T_A.
The junction-to-air thermal resistance, R_{θJA}, in the table is that of a device installed on a high-K test board for leaded surface-mount packages. Use these equations to calculate the value for each parameter:
T_J = T_A + R_{θJA} × P, where P is the power dissipated in the device.
T_{J(max)} = T_S = T_A + R_{θJA} × P_S, where T_{J(max)} is the maximum allowed junction temperature.
P_S = I_S × V_I, where V_I is the maximum input voltage.

6.9 Electrical Characteristics—5-V Supply

 $V_{CC1} = V_{CC2} = 5\text{ V} \pm 10\%$ (over recommended operating conditions unless otherwise noted)

PARAMETER		TEST CONDITIONS	MIN	TYP	MAX	UNIT
V_{OH}	High-level output voltage	$I_{OH} = -4\text{ mA}$; See 7-1	$V_{CCO} - 0.4$			V
V_{OL}	Low-level output voltage	$I_{OL} = 4\text{ mA}$; See 7-1			0.4	V
$V_{IT+(IN)}$	Rising input switching threshold			$0.7 \times V_{CCI}^{(1)}$		V
$V_{IT-(IN)}$	Falling input switching threshold		$0.3 \times V_{CCI}$			V
$V_{I(HYS)}$	Input threshold voltage hysteresis		$0.1 \times V_{CCI}$			V
I_{IH}	High-level input current	$V_{IH} = V_{CCI}^{(1)}$ at INx			10	μA
I_{IL}	Low-level input current	$V_{IL} = 0\text{ V}$ at INx	-10			μA
CMTI	Common mode transient immunity	$V_I = V_{CC}$ or 0 V , $V_{CM} = 1200\text{ V}$	100	150		kV/us
C_i	Input Capacitance ⁽²⁾	$V_I = V_{CC}/2 + 0.4 \times \sin(2\pi ft)$, $f = 2\text{ MHz}$, $V_{CC} = 5\text{ V}$; See 7-3		2.8		pF

(1) V_{CCI} = Input-side V_{CC} ; V_{CCO} = Output-side V_{CC}

(2) Measured from input pin to same side ground.

6.10 Supply Current Characteristics—5-V Supply

 $V_{CC1} = V_{CC2} = 5\text{ V} \pm 10\%$ (over recommended operating conditions unless otherwise noted)

PARAMETER	TEST CONDITIONS	SUPPLY CURRENT	MIN	TYP	MAX	UNIT	
ISO6720B							
Supply current - DC signal ⁽²⁾	$V_I = V_{CCI}^{(1)}$ (ISO6720B), $V_I = 0\text{ V}$ (ISO6720B with F suffix)	I_{CC1}		1.1	1.7	mA	
		I_{CC2}		1.3	2.1		
	$V_I = 0\text{ V}$ (ISO6720B), $V_I = V_{CC1}$ (ISO6720B with F suffix)	I_{CC1}		3.2	4.6		
		I_{CC2}		1.4	2.3		
Supply current - AC signal ⁽³⁾	All channels switching with square wave clock input; $C_L = 15\text{ pF}$	1 Mbps	I_{CC1}		2.1		3.1
			I_{CC2}		1.5		2.3
		10 Mbps	I_{CC1}		2.2		3.2
			I_{CC2}		2.7		3.6
		50 Mbps	I_{CC1}		2.5	3.6	
			I_{CC2}		7.9	9.5	
ISO6721B							
Supply current - DC signal ⁽²⁾	$V_I = V_{CCI}^{(1)}$ (ISO6721B); $V_I = 0\text{ V}$ (ISO6721B with F suffix)	I_{CC1}, I_{CC2}		1.2	2.1	mA	
		I_{CC1}, I_{CC2}		2.3	3.5		
Supply current - AC signal ⁽³⁾	All channels switching with square wave clock input; $C_L = 15\text{ pF}$	1 Mbps	I_{CC1}, I_{CC2}		1.9		2.9
		10 Mbps	I_{CC1}, I_{CC2}		2.5		3.6
		50 Mbps	I_{CC1}, I_{CC2}		5.2		6.7

$V_{CC1} = V_{CC2} = 5\text{ V} \pm 10\%$ (over recommended operating conditions unless otherwise noted)

PARAMETER	TEST CONDITIONS	SUPPLY CURRENT	MIN	TYP	MAX	UNIT
ISO6721RB						
Supply current - DC signal (2)	$V_I = V_{CCI}$ (1)(ISO6721R); $V_I = 0\text{ V}$ (ISO6721R with F suffix)	I_{CC1}, I_{CC2}		2.1	3.3	mA
	$V_I = 0\text{ V}$ (ISO6721R); $V_I = V_{CCI}$ (ISO6721R with F suffix)	I_{CC1}, I_{CC2}		3.2	4.7	
Supply current - AC signal (3)	All channels switching with square wave clock input; $C_L = 15\text{ pF}$	1 Mbps	I_{CC1}, I_{CC2}	2.7	4.1	
		10 Mbps	I_{CC1}, I_{CC2}	3.3	4.7	
		50 Mbps	I_{CC1}, I_{CC2}	6.0	7.7	

- (1) $V_{CCI} = \text{Input-side } V_{CC}$
- (2) Supply current valid for $ENx = V_{CCx}$ and $ENx = 0\text{ V}$
- (3) Supply current valid for $ENx = V_{CCx}$

6.11 Electrical Characteristics—3.3-V Supply

 $V_{CC1} = V_{CC2} = 3.3\text{ V} \pm 10\%$ (over recommended operating conditions unless otherwise noted)

PARAMETER		TEST CONDITIONS	MIN	TYP	MAX	UNIT
V_{OH}	High-level output voltage	$I_{OH} = -2\text{ mA}$; See 7-1	$V_{CCO} - 0.2$			V
V_{OL}	Low-level output voltage	$I_{OL} = 2\text{ mA}$; See 7-1			0.2	V
$V_{IT+(IN)}$	Rising input switching threshold			$0.7 \times V_{CCI}^{(1)}$		V
$V_{IT-(IN)}$	Falling input switching threshold		$0.3 \times V_{CCI}$			V
$V_{I(HYS)}$	Input threshold voltage hysteresis		$0.1 \times V_{CCI}$			V
I_{IH}	High-level input current	$V_{IH} = V_{CCI}^{(1)}$ at INx			10	μA
I_{IL}	Low-level input current	$V_{IL} = 0\text{ V}$ at INx	-10			μA
CMTI	Common mode transient immunity	$V_I = V_{CC}$ or 0 V, $V_{CM} = 1200\text{ V}$	100	150		kV/us
C_i	Input Capacitance ⁽²⁾	$V_I = V_{CC}/2 + 0.4 \times \sin(2\pi f t)$, $f = 2\text{ MHz}$, $V_{CC} = 3.3\text{ V}$; See 7-3		2.8		pF

 (1) V_{CCI} = Input-side V_{CC} ; V_{CCO} = Output-side V_{CC}

(2) Measured from input pin to same side ground.

6.12 Supply Current Characteristics—3.3-V Supply

 $V_{CC1} = V_{CC2} = 3.3\text{ V} \pm 10\%$ (over recommended operating conditions unless otherwise noted)

PARAMETER	TEST CONDITIONS	SUPPLY CURRENT	MIN	TYP	MAX	UNIT	
ISO6720B							
Supply current - DC signal ⁽²⁾	$V_I = V_{CCI}^{(1)}$ (ISO6720B), $V_I = 0\text{ V}$ (ISO6720B with F suffix)	I_{CC1}		1.1	1.6	mA	
		I_{CC2}		1.3	2		
	$V_I = 0\text{ V}$ (ISO6720B), $V_I = V_{CC1}$ (ISO6720B with F suffix)	I_{CC1}		3.2	4.5		
		I_{CC2}		1.4	2.2		
Supply current - AC signal ⁽³⁾	All channels switching with square wave clock input; $C_L = 15\text{ pF}$	1 Mbps	I_{CC1}		2.1		3.1
			I_{CC2}		1.4		2.2
		10 Mbps	I_{CC1}		2.2		3.1
			I_{CC2}		2.3		3.2
		50 Mbps	I_{CC1}		2.4	3.4	
			I_{CC2}		6	7.3	
ISO6721B							
Supply current - DC signal ⁽²⁾	$V_I = V_{CCI}^{(1)}$ (ISO6721B); $V_I = 0\text{ V}$ (ISO6721B with F suffix)	I_{CC1}, I_{CC2}		1.2	2.1	mA	
	$V_I = 0\text{ V}$ (ISO6721B); $V_I = V_{CCI}$ (ISO6721B with F suffix)	I_{CC1}, I_{CC2}		2.3	3.5		
Supply current - AC signal ⁽³⁾	All channels switching with square wave clock input; $C_L = 15\text{ pF}$	1 Mbps	I_{CC1}, I_{CC2}		1.8		2.8
		10 Mbps	I_{CC1}, I_{CC2}		2.3	3.3	
		50 Mbps	I_{CC1}, I_{CC2}		4.2	5.5	

$V_{CC1} = V_{CC2} = 3.3\text{ V} \pm 10\%$ (over recommended operating conditions unless otherwise noted)

PARAMETER	TEST CONDITIONS	SUPPLY CURRENT	MIN	TYP	MAX	UNIT
ISO6721RB						
Supply current - DC signal (2)	$V_I = V_{CCI}$ (1) (ISO6721R); $V_I = 0\text{ V}$ (ISO6721R with F suffix)	I_{CC1}, I_{CC2}		2.1	3.3	mA
	$V_I = 0\text{ V}$ (ISO6721R); $V_I = V_{CCI}$ (ISO6721R with F suffix)	I_{CC1}, I_{CC2}		3.2	4.7	mA
Supply current - AC signal (3)	All channels switching with square wave clock input; $C_L = 15\text{ pF}$	1 Mbps	I_{CC1}, I_{CC2}	2.7	4.0	mA
		10 Mbps	I_{CC1}, I_{CC2}	3.1	4.5	mA
		50 Mbps	I_{CC1}, I_{CC2}	5.0	6.7	mA

- (1) $V_{CCI} = \text{Input-side } V_{CC}$
- (2) Supply current valid for $ENx = V_{CCx}$ and $ENx = 0\text{ V}$
- (3) Supply current valid for $ENx = V_{CCx}$

6.13 Electrical Characteristics—2.5-V Supply

 $V_{CC1} = V_{CC2} = 2.5\text{ V} \pm 10\%$ (over recommended operating conditions unless otherwise noted)

PARAMETER		TEST CONDITIONS	MIN	TYP	MAX	UNIT
V_{OH}	High-level output voltage	$I_{OH} = -1\text{ mA}$; See 7-1	$V_{CCO} - 0.1$			V
V_{OL}	Low-level output voltage	$I_{OL} = 1\text{ mA}$; See 7-1			0.1	V
$V_{IT+(IN)}$	Rising input switching threshold			$0.7 \times V_{CCI}^{(1)}$		V
$V_{IT-(IN)}$	Falling input switching threshold		$0.3 \times V_{CCI}$			V
$V_{I(HYS)}$	Input threshold voltage hysteresis		$0.1 \times V_{CCI}$			V
I_{IH}	High-level input current	$V_{IH} = V_{CCI}^{(1)}$ at INx			10	μA
I_{IL}	Low-level input current	$V_{IL} = 0\text{ V}$ at INx	-10			μA
CMTI	Common mode transient immunity	$V_I = V_{CC}$ or 0 V , $V_{CM} = 1200\text{ V}$	100	150		kV/us
C_i	Input Capacitance ⁽²⁾	$V_I = V_{CC}/2 + 0.4 \times \sin(2\pi f t)$, $f = 2\text{ MHz}$, $V_{CC} = 2.5\text{ V}$; See 7-3		2.8		pF

 (1) $V_{CCI} =$ Input-side V_{CC} ; $V_{CCO} =$ Output-side V_{CC}

(2) Measured from input pin to same side ground.

6.14 Supply Current Characteristics—2.5-V Supply

 $V_{CC1} = V_{CC2} = 2.5\text{ V} \pm 10\%$ (over recommended operating conditions unless otherwise noted)

PARAMETER	TEST CONDITIONS	SUPPLY CURRENT	MIN	TYP	MAX	UNIT	
ISO6720B							
Supply current - DC signal ⁽²⁾	$V_I = V_{CCI}^{(1)}$ (ISO6720B), $V_I = 0\text{ V}$ (ISO6720B with F suffix)	I_{CC1}		1.1	1.6	mA	
		I_{CC2}		1.3	2		
	$V_I = 0\text{ V}$ (ISO6720B), $V_I = V_{CC1}$ (ISO6720B with F suffix)	I_{CC1}		3.1	4.5		
		I_{CC2}		1.4	2.2		
Supply current - AC signal ⁽³⁾	All channels switching with square wave clock input; $C_L = 15\text{ pF}$	1 Mbps	I_{CC1}		2.1		3.1
			I_{CC2}		1.4		2.2
		10 Mbps	I_{CC1}		2.1		3.1
			I_{CC2}		2		2.9
		50 Mbps	I_{CC1}		2.3	3.3	
			I_{CC2}		4.8	6	
ISO6721B							
Supply current - DC signal ⁽²⁾	$V_I = V_{CCI}^{(1)}$ (ISO6721B); $V_I = 0\text{ V}$ (ISO6721B with F suffix)	I_{CC1}, I_{CC2}		1.2	2.1	mA	
		I_{CC1}, I_{CC2}		2.3	3.5		
Supply current - AC signal ⁽³⁾	All channels switching with square wave clock input; $C_L = 15\text{ pF}$	1 Mbps	I_{CC1}, I_{CC2}		1.8		2.8
			10 Mbps	I_{CC1}, I_{CC2}			2.1
		50 Mbps	I_{CC1}, I_{CC2}		3.6		4.9

$V_{CC1} = V_{CC2} = 2.5\text{ V} \pm 10\%$ (over recommended operating conditions unless otherwise noted)

PARAMETER	TEST CONDITIONS	SUPPLY CURRENT	MIN	TYP	MAX	UNIT
ISO6721RB						
Supply current - DC signal (2)	$V_I = V_{CCI}$ (1)(ISO6721R); $V_I = 0\text{ V}$ (ISO6721R with F suffix)	I_{CC1}, I_{CC2}		2.1	3.3	mA
	$V_I = 0\text{ V}$ (ISO6721R); $V_I = V_{CCI}$ (ISO6721R with F suffix)	I_{CC1}, I_{CC2}		3.2	4.7	mA
Supply current - AC signal (3)	All channels switching with square wave clock input; $C_L = 15\text{ pF}$	1 Mbps	I_{CC1}, I_{CC2}	2.7	4.0	mA
		10 Mbps	I_{CC1}, I_{CC2}	3.0	4.4	mA
		50 Mbps	I_{CC1}, I_{CC2}	4.4	6	mA

- (1) $V_{CCI} = \text{Input-side } V_{CC}$
- (2) Supply current valid for $ENx = V_{CCx}$ and $ENx = 0\text{V}$
- (3) Supply current valid for $ENx = V_{CCx}$

6.15 Electrical Characteristics—1.8-V Supply

 $V_{CC1} = V_{CC2} = 1.8\text{ V} \pm 5\%$ (over recommended operating conditions unless otherwise noted)

PARAMETER		TEST CONDITIONS	MIN	TYP	MAX	UNIT
V_{OH}	High-level output voltage	$I_{OH} = -1\text{ mA}$; See 7-1	$V_{CCO} - 0.1$			V
V_{OL}	Low-level output voltage	$I_{OL} = 1\text{ mA}$; See 7-1			0.1	V
$V_{IT+(IN)}$	Rising input switching threshold			$0.7 \times V_{CC1}$ ⁽¹⁾		V
$V_{IT-(IN)}$	Falling input switching threshold		$0.3 \times V_{CC1}$			V
$V_{I(HYS)}$	Input threshold voltage hysteresis		$0.1 \times V_{CC1}$			V
I_{IH}	High-level input current	$V_{IH} = V_{CC1}$ ⁽¹⁾ at INx			10	μA
I_{IL}	Low-level input current	$V_{IL} = 0\text{ V}$ at INx	-10			μA
CMTI	Common mode transient immunity	$V_I = V_{CC}$ or 0 V , $V_{CM} = 1200\text{ V}$	100	150		kV/us
C_i	Input Capacitance ⁽²⁾	$V_I = V_{CC}/2 + 0.4 \times \sin(2\pi ft)$, $f = 2\text{ MHz}$, $V_{CC} = 1.8\text{ V}$; See 7-3		2.8		pF

(1) V_{CC1} = Input-side V_{CC} ; V_{CCO} = Output-side V_{CC}

(2) Measured from input pin to same side ground.

6.16 Supply Current Characteristics—1.8-V Supply

 $V_{CC1} = V_{CC2} = 1.8\text{ V} \pm 5\%$ (over recommended operating conditions unless otherwise noted)

PARAMETER	TEST CONDITIONS	SUPPLY CURRENT	MIN	TYP	MAX	UNIT
ISO6720B						
Supply current - DC signal ⁽²⁾	$V_I = V_{CC1}$ ⁽¹⁾ (ISO6720B), $V_I = 0\text{ V}$ (ISO6720B with F suffix)	I_{CC1}		0.8	1.5	mA
		I_{CC2}		1.2	2.1	
	$V_I = 0\text{ V}$ (ISO6720B), $V_I = V_{CC1}$ (ISO6720B with F suffix)	I_{CC1}		2.8	4.3	
		I_{CC2}		1.3	2.2	
Supply current - AC signal ⁽³⁾	All channels switching with square wave clock input; $C_L = 15\text{ pF}$	1 Mbps	I_{CC1}		1.8	2.9
			I_{CC2}		1.3	2.2
		10 Mbps	I_{CC1}		1.8	2.9
			I_{CC2}		1.8	2.7
		50 Mbps	I_{CC1}		2	3.1
			I_{CC2}		3.8	4.9
ISO6721B						
Supply current - DC signal ⁽²⁾	$V_I = V_{CC1}$ ⁽¹⁾ (ISO6721B); $V_I = 0\text{ V}$ (ISO6721B with F suffix)	I_{CC1}, I_{CC2}		1.1	2	mA
		I_{CC1}, I_{CC2}		2.1	3.4	
Supply current - AC signal ⁽³⁾	All channels switching with square wave clock input; $C_L = 15\text{ pF}$	1 Mbps	I_{CC1}, I_{CC2}		1.6	2.7
		10 Mbps	I_{CC1}, I_{CC2}		1.9	3
		50 Mbps	I_{CC1}, I_{CC2}		3	4.2

$V_{CC1} = V_{CC2} = 1.8\text{ V} \pm 5\%$ (over recommended operating conditions unless otherwise noted)

PARAMETER	TEST CONDITIONS	SUPPLY CURRENT	MIN	TYP	MAX	UNIT
ISO6721RB						
Supply current - DC signal ⁽²⁾	$V_I = V_{CCI}$ ⁽¹⁾ (ISO6721R); $V_I = 0\text{ V}$ (ISO6721R with F suffix)	I_{CC1}, I_{CC2}		1.8	3.1	mA
	$V_I = 0\text{ V}$ (ISO6721R); $V_I = V_{CCI}$ (ISO6721R with F suffix)	I_{CC1}, I_{CC2}		2.9	4.5	mA
Supply current - AC signal ⁽³⁾	All channels switching with square wave clock input; $C_L = 15\text{ pF}$	1 Mbps	I_{CC1}, I_{CC2}	2.4	3.8	mA
		10 Mbps	I_{CC1}, I_{CC2}	2.6	4.1	mA
		50 Mbps	I_{CC1}, I_{CC2}	3.7	5.3	mA

- (1) $V_{CCI} = \text{Input-side } V_{CC}$
- (2) Supply current valid for $ENx = V_{CCx}$ and $ENx = 0\text{V}$
- (3) Supply current valid for $ENx = V_{CCx}$

6.17 Switching Characteristics—5-V Supply

 $V_{CC1} = V_{CC2} = 5\text{ V} \pm 10\%$ (over recommended operating conditions unless otherwise noted)

PARAMETER		TEST CONDITIONS	MIN	TYP	MAX	UNIT
t_{PLH} , t_{PHL}	Propagation delay time	See 7-1		11	18	ns
$t_{P(dft)}$	Propagation delay drift			8		ps/°C
t_{UI}	Minimum pulse width	See 7-1	20			ns
PWD	Pulse width distortion ⁽¹⁾ $ t_{PHL} - t_{PLH} $	See 7-1		0.2	7	ns
$t_{sk(o)}$	Channel-to-channel output skew time ⁽²⁾	Same direction channels			6	ns
$t_{sk(p-p)}$	Part-to-part skew time ⁽³⁾				6	ns
t_r	Output signal rise time	See 7-1		2.6	4.5	ns
t_f	Output signal fall time			2.6	4.5	ns
t_{PU}	Time from UVLO to valid output data				300	us
t_{DO}	Default output delay time from input power loss	Measured from the time V_{CC} goes below 1.2V. See 7-2		0.1	0.3	us
t_{ie}	Time interval error	$2^{16} - 1$ PRBS data at 50 Mbps		1		ns

(1) Also known as pulse skew.

(2) $t_{sk(o)}$ is the skew between outputs of a single device with all driving inputs connected together and the outputs switching in the same direction while driving identical loads.

(3) $t_{sk(pp)}$ is the magnitude of the difference in propagation delay times between any terminals of different devices switching in the same direction while operating at identical supply voltages, temperature, input signals and loads.

6.18 Switching Characteristics—3.3-V Supply

 $V_{CC1} = V_{CC2} = 3.3\text{ V} \pm 10\%$ (over recommended operating conditions unless otherwise noted)

PARAMETER		TEST CONDITIONS	MIN	TYP	MAX	UNIT
t_{PLH} , t_{PHL}	Propagation delay time	See 7-1		11	18	ns
$t_{P(dft)}$	Propagation delay drift			9.2		ps/°C
t_{UI}	Minimum pulse width	See 7-1	20			ns
PWD	Pulse width distortion ⁽¹⁾ $ t_{PHL} - t_{PLH} $	See 7-1		0.5	7	ns
$t_{sk(o)}$	Channel-to-channel output skew time ⁽²⁾	Same direction channels			6	ns
$t_{sk(p-p)}$	Part-to-part skew time ⁽³⁾				6	ns
t_r	Output signal rise time	See 7-1		1.6	3.2	ns
t_f	Output signal fall time			1.6	3.2	ns
t_{PU}	Time from UVLO to valid output data				300	us
t_{DO}	Default output delay time from input power loss	Measured from the time V_{CC} goes below 1.2V. See 7-2		0.1	0.3	us
t_{ie}	Time interval error	$2^{16} - 1$ PRBS data at 50 Mbps		1		ns

(1) Also known as pulse skew.

(2) $t_{sk(o)}$ is the skew between outputs of a single device with all driving inputs connected together and the outputs switching in the same direction while driving identical loads.

(3) $t_{sk(pp)}$ is the magnitude of the difference in propagation delay times between any terminals of different devices switching in the same direction while operating at identical supply voltages, temperature, input signals and loads.

6.19 Switching Characteristics—2.5-V Supply

$V_{CC1} = V_{CC2} = 2.5\text{ V} \pm 10\%$ (over recommended operating conditions unless otherwise noted)

PARAMETER		TEST CONDITIONS	MIN	TYP	MAX	UNIT
t_{PLH} , t_{PHL}	Propagation delay time	See 7-1		12	20.5	ns
$t_{P(dft)}$	Propagation delay drift			14.3		ps/°C
t_{UI}	Minimum pulse width	See 7-1	20			ns
PWD	Pulse width distortion ⁽¹⁾ $ t_{PHL} - t_{PLH} $	See 7-1		0.6	7.1	ns
$t_{sk(o)}$	Channel-to-channel output skew time ⁽²⁾	Same direction channels			6	ns
$t_{sk(p-p)}$	Part-to-part skew time ⁽³⁾				6.1	ns
t_r	Output signal rise time	See 7-1		2	4	ns
t_f	Output signal fall time			2	4	ns
t_{PU}	Time from UVLO to valid output data				300	us
t_{DO}	Default output delay time from input power loss	Measured from the time V_{CC} goes below 1.2V. See 7-2		0.1	0.3	us
t_{ie}	Time interval error	$2^{16} - 1$ PRBS data at 50 Mbps		1		ns

- (1) Also known as pulse skew.
- (2) $t_{sk(o)}$ is the skew between outputs of a single device with all driving inputs connected together and the outputs switching in the same direction while driving identical loads.
- (3) $t_{sk(pp)}$ is the magnitude of the difference in propagation delay times between any terminals of different devices switching in the same direction while operating at identical supply voltages, temperature, input signals and loads.

6.20 Switching Characteristics—1.8-V Supply

$V_{CC1} = V_{CC2} = 1.8\text{ V} \pm 5\%$ (over recommended operating conditions unless otherwise noted)

PARAMETER		TEST CONDITIONS	MIN	TYP	MAX	UNIT
t_{PLH} , t_{PHL}	Propagation delay time	See 7-1		15	24	ns
$t_{P(dft)}$	Propagation delay drift			15.2		ps/°C
t_{UI}	Minimum pulse width	See 7-1	20			ns
PWD	Pulse width distortion ⁽¹⁾ $ t_{PHL} - t_{PLH} $	See 7-1		0.7	8.2	ns
$t_{sk(o)}$	Channel-to-channel output skew time ⁽²⁾	Same direction channels			6	ns
$t_{sk(p-p)}$	Part-to-part skew time ⁽³⁾				8.8	ns
t_r	Output signal rise time	See 7-1		2.7	5.3	ns
t_f	Output signal fall time			2.7	5.3	ns
t_{PU}	Time from UVLO to valid output data				300	us
t_{DO}	Default output delay time from input power loss	Measured from the time V_{CC} goes below 1.2V. See 7-2		0.1	0.3	us
t_{ie}	Time interval error	$2^{16} - 1$ PRBS data at 50 Mbps		1		ns

- (1) Also known as pulse skew.
- (2) $t_{sk(o)}$ is the skew between outputs of a single device with all driving inputs connected together and the outputs switching in the same direction while driving identical loads.
- (3) $t_{sk(pp)}$ is the magnitude of the difference in propagation delay times between any terminals of different devices switching in the same direction while operating at identical supply voltages, temperature, input signals and loads.

6.21 Insulation Characteristics Curves

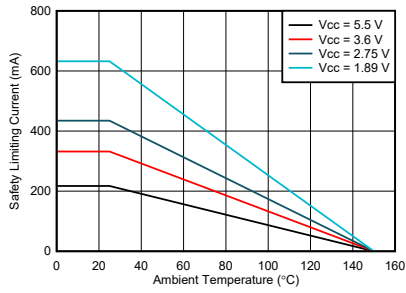

6-1. Thermal Derating Curve for Safety Limiting Current for D-8 Package - ISO672x

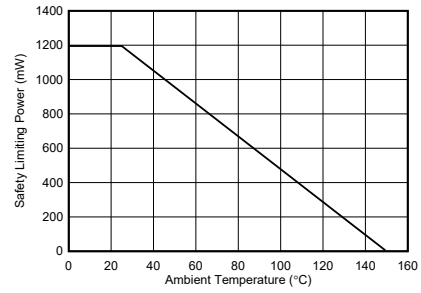

6-2. Thermal Derating Curve for Safety Limiting Power for D-8 Package - ISO672x

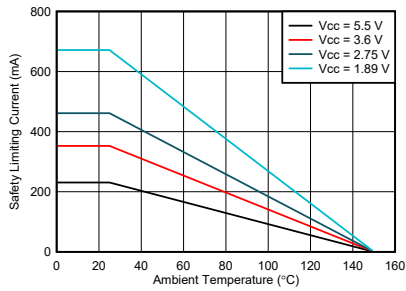

6-3. Thermal Derating Curve for Safety Limiting Current for D-8 Package - ISO6721R

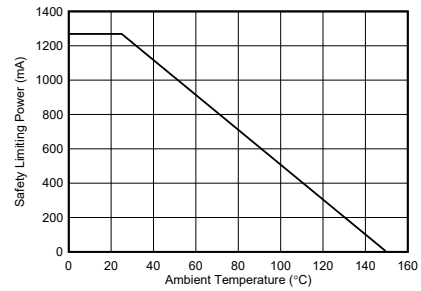

6-4. Thermal Derating Curve for Safety Limiting Power for D-8 Package - ISO6721R

6.22 Typical Characteristics

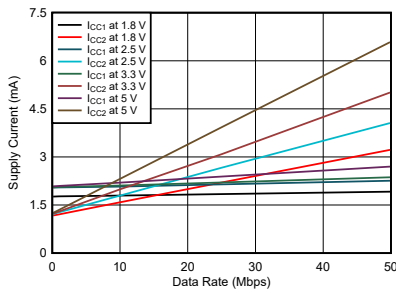

$T_A = 25^\circ\text{C}$ $C_L = 15\text{ pF}$

6-5. ISO6720B Supply Current vs Data Rate (With 15-pF Load)

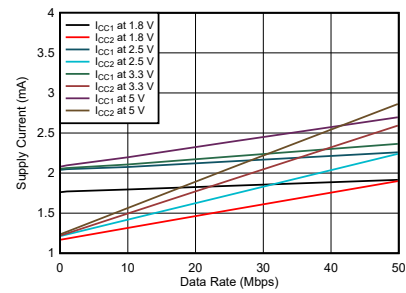

$T_A = 25^\circ\text{C}$ $C_L = \text{No Load}$

6-6. ISO6720B Supply Current vs Data Rate (With No Load)

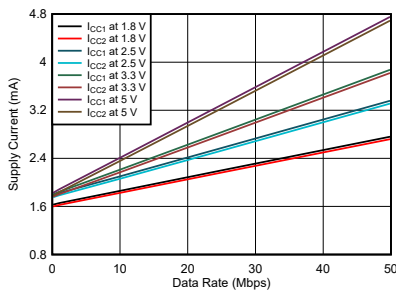

$T_A = 25^\circ\text{C}$ $C_L = 15\text{ pF}$

6-7. ISO6721B Supply Current vs Data Rate (With 15-pF Load)

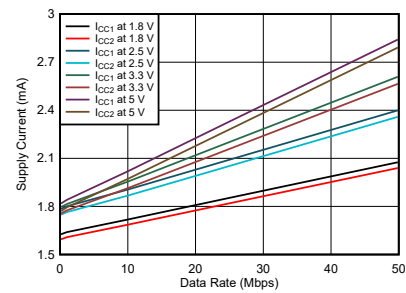

$T_A = 25^\circ\text{C}$ $C_L = \text{No Load}$

6-8. ISO6721B Supply Current vs Data Rate (With No Load)

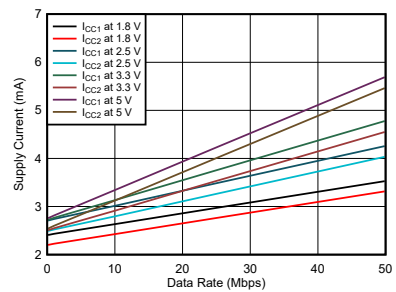

$T_A = 25^\circ\text{C}$ $C_L = 15\text{ pF}$

6-9. ISO6721RB Supply Current vs Data Rate (With 15-pF Load)

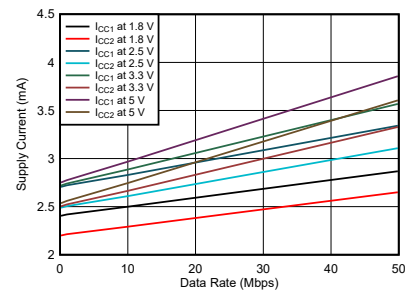

$T_A = 25^\circ\text{C}$ $C_L = \text{No Load}$

6-10. ISO6721RB Supply Current vs Data Rate (With No Load)

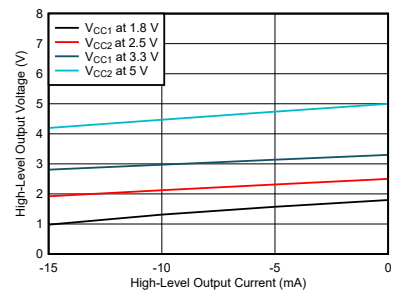

$T_A = 25^\circ\text{C}$

6-11. High-Level Output Voltage vs High-level Output Current

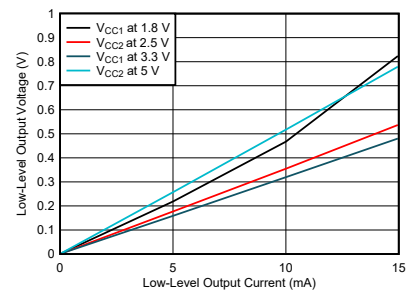

$T_A = 25^\circ\text{C}$

6-12. Low-Level Output Voltage vs Low-Level Output Current

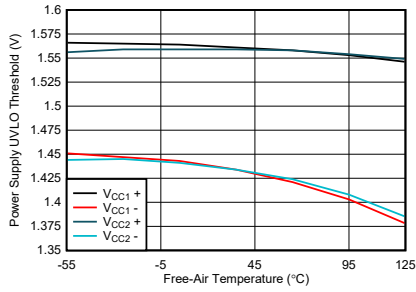

6-13. Power Supply Undervoltage Threshold vs Free-Air Temperature

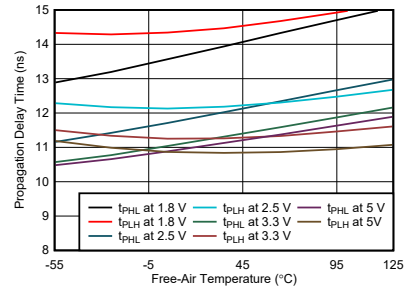

6-14. Propagation Delay Time vs Free-Air Temperature

7 Parameter Measurement Information

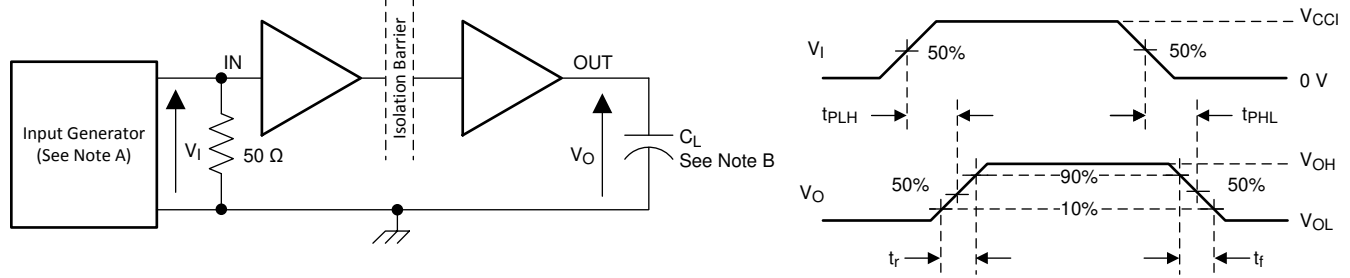

- A. The input pulse is supplied by a generator having the following characteristics: PRR \leq 50 kHz, 50% duty cycle, $t_r \leq 3$ ns, $t_f \leq 3$ ns, $Z_0 = 50 \Omega$. At the input, 50Ω resistor is required to terminate Input Generator signal. It is not needed in actual application.
- B. $C_L = 15$ pF and includes instrumentation and fixture capacitance within $\pm 20\%$.

7-1. Switching Characteristics Test Circuit and Voltage Waveforms

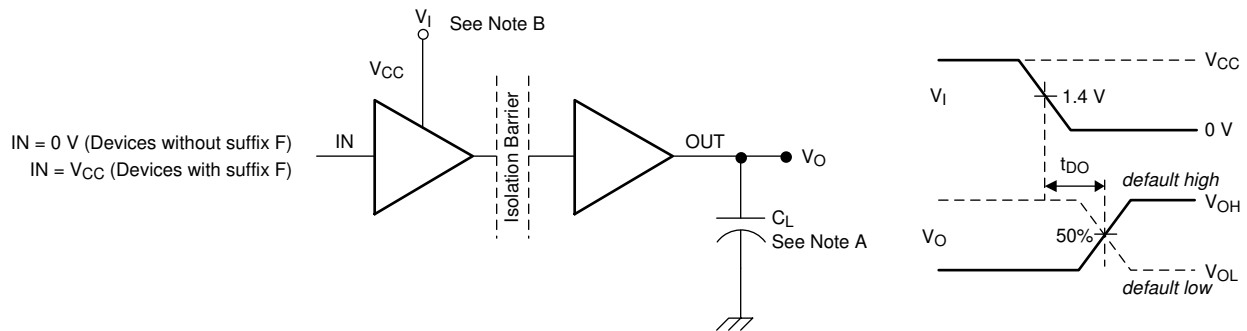

- A. $C_L = 15$ pF and includes instrumentation and fixture capacitance within $\pm 20\%$.
- B. Power Supply Ramp Rate = 10 mV/ns

7-2. Default Output Delay Time Test Circuit and Voltage Waveforms

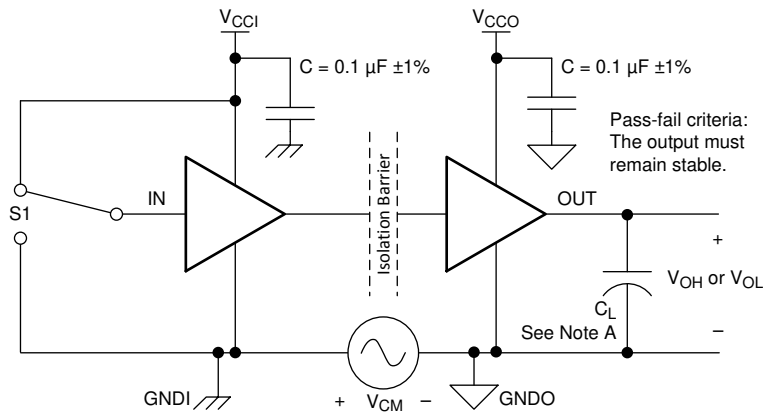

- A. $C_L = 15$ pF and includes instrumentation and fixture capacitance within $\pm 20\%$.

7-3. Common-Mode Transient Immunity Test Circuit

8 Detailed Description

8.1 Overview

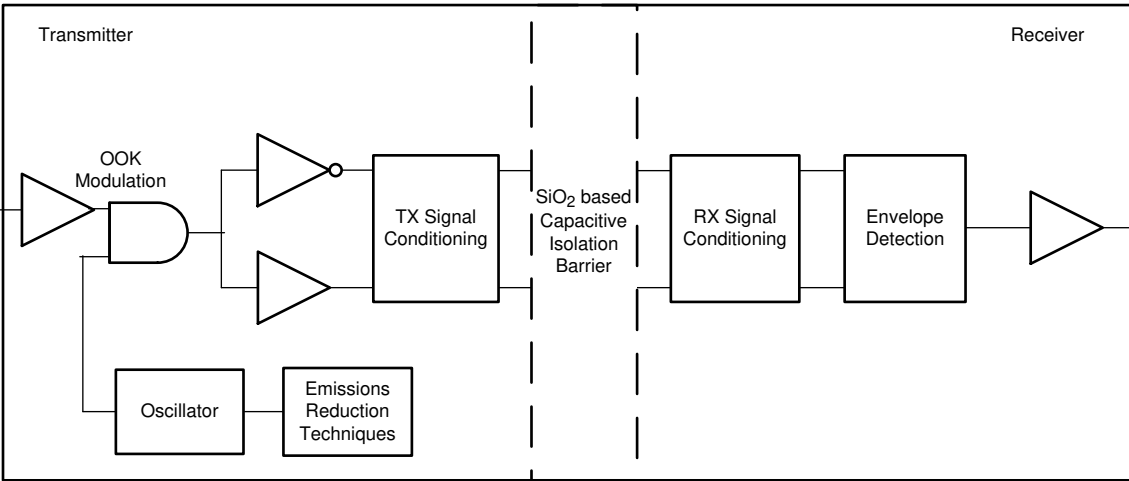
The ISO672xB family of devices has an ON-OFF keying (OOK) modulation scheme to transmit the digital data across a silicon dioxide based isolation barrier. The transmitter sends a high frequency carrier across the barrier to represent one digital state and sends no signal to represent the other digital state. The receiver demodulates the signal after advanced signal conditioning and produces the output through a buffer stage. These devices also incorporate advanced circuit techniques to maximize the CMTI performance and minimize the radiated emissions due the high frequency carrier and IO buffer switching. The conceptual block diagram of a digital capacitive isolator, , shows a functional block diagram of a typical channel.

8.2 Functional Block Diagram

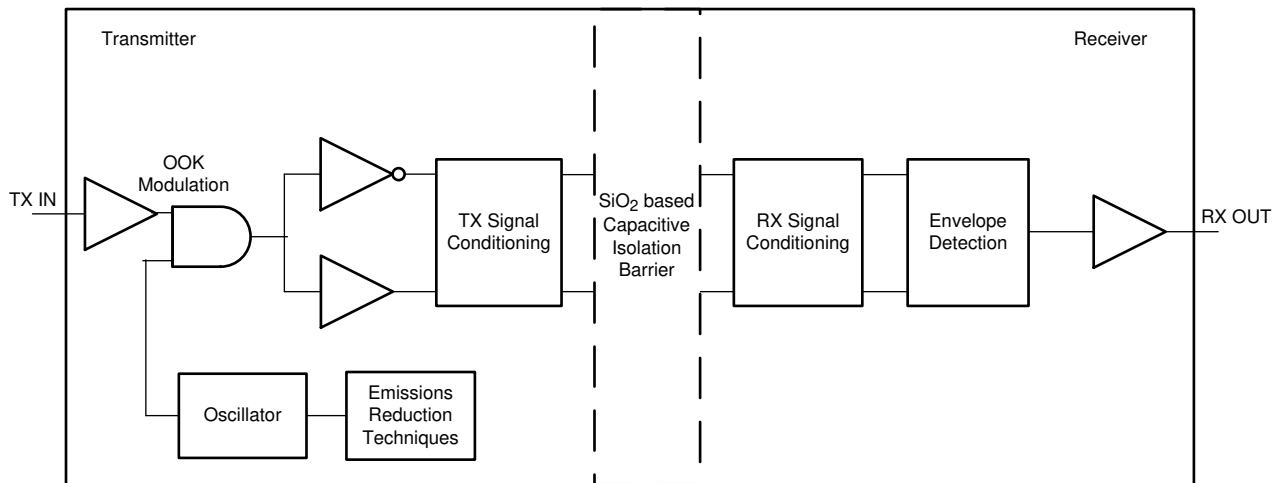

 **8-1. Conceptual Block Diagram of a Digital Capacitive Isolator**

 **8-2** shows a conceptual detail of how the OOK scheme works.

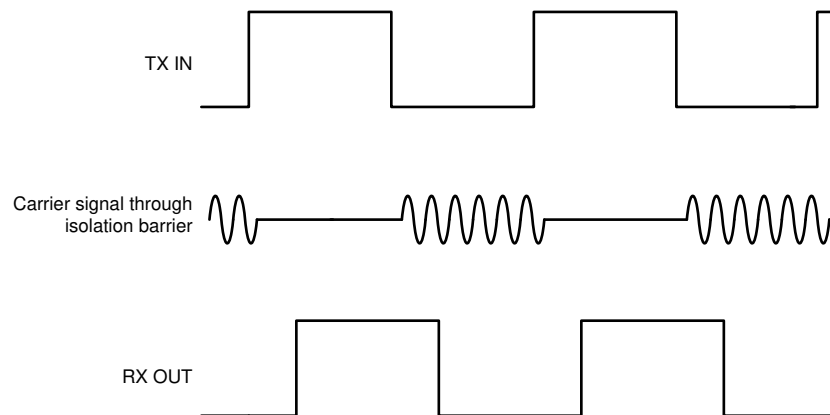

 **8-2. On-Off Keying (OOK) Based Modulation Scheme**

8.3 Feature Description

The ISO672xB family of devices is available in two channel configurations and default output state options to enable a variety of application uses. 表 8-1 lists the device features of the ISO672xB devices.

表 8-1. Device Features

PART NUMBER	MAXIMUM DATA RATE	CHANNEL DIRECTION	DEFAULT OUTPUT STATE	PACKAGE	RATED ISOLATION ⁽¹⁾
ISO6720B	50 Mbps	2 Forward, 0 Reverse	High	D-8	3000 V _{RMS} / 4242 V _{PK}
ISO6720FB	50 Mbps	2 Forward, 0 Reverse	Low	D-8	3000 V _{RMS} / 4242 V _{PK}
ISO6721B	50 Mbps	1 Forward, 1 Reverse	High	D-8	3000 V _{RMS} / 4242 V _{PK}
ISO6721FB	50 Mbps	1 Forward, 1 Reverse	Low	D-8	3000 V _{RMS} / 4242 V _{PK}
ISO6721RB	50 Mbps	1 Forward, 1 Reverse	High	D-8	3000 V _{RMS} / 4242 V _{PK}
ISO6721RFB	50 Mbps	1 Forward, 1 Reverse	Low	D-8	3000 V _{RMS} / 4242 V _{PK}

(1) See [Safety-Related Certifications](#) for detailed isolation ratings.

8.3.1 Electromagnetic Compatibility (EMC) Considerations

Many applications in harsh industrial environment are sensitive to disturbances such as electrostatic discharge (ESD), electrical fast transient (EFT), surge and electromagnetic emissions. These electromagnetic disturbances are regulated by international standards such as IEC 61000-4-x and CISPR 32. Although system-level performance and reliability depends, to a large extent, on the application board design and layout, the ISO672xB family of devices incorporates many chip-level design improvements for overall system robustness. Some of these improvements include:

- Robust ESD protection cells for input and output signal pins and inter-chip bond pads.
- Low-resistance connectivity of ESD cells to supply and ground pins.
- Enhanced performance of high voltage isolation capacitor for better tolerance of ESD, EFT and surge events.
- Bigger on-chip decoupling capacitors to bypass undesirable high energy signals through a low impedance path.
- PMOS and NMOS devices isolated from each other by using guard rings to avoid triggering of parasitic SCRs.
- Reduced common mode currents across the isolation barrier by ensuring purely differential internal operation.

8.4 Device Functional Modes

表 8-2 lists the functional modes for the ISO672xB devices.

表 8-2. Function Table

V_{CC1} ⁽¹⁾	V_{CC0}	INPUT (INx) ⁽²⁾	OUTPUT (OUTx)	COMMENTS
PU	PU	H	H	Normal Operation: A channel output assumes the logic state of the input.
		L	L	
		Open	Default	Default mode: When INx is open, the corresponding channel output goes to the default logic state. The default is <i>High</i> for ISO672xB and <i>Low</i> for ISO672xB with F suffix.
PD	PU	X	Default	Default mode: When V_{CC1} is unpowered, a channel output assumes the logic state based on the selected default option. The default is <i>High</i> for ISO672xB and <i>Low</i> for ISO672xB with F suffix. When V_{CC1} transitions from unpowered to powered-up, a channel output assumes the logic state of the input. When V_{CC1} transitions from powered-up to unpowered, channel output assumes the selected default state.
X	PD	X	Undetermined	When V_{CC0} is unpowered, a channel output is undetermined ⁽³⁾ . When V_{CC0} transitions from unpowered to powered-up, a channel output assumes the logic state of the input

- (1) V_{CC1} = Input-side V_{CC} ; V_{CC0} = Output-side V_{CC} ; PU = Powered up ($V_{CC} \geq 1.71V$); PD = Powered down ($V_{CC} \leq 1.05V$); X = Irrelevant; H = High level; L = Low level
- (2) A strongly driven input signal can weakly power the floating V_{CC} via an internal protection diode and cause undetermined output.
- (3) The outputs are in undetermined state when $1.89V < V_{CC1}$, $V_{CC0} < 2.25V$ and $1.05V < V_{CC1}$, $V_{CC0} < 1.71V$

8.4.1 Device I/O Schematics



图 8-3. Device I/O Schematics

9 Application and Implementation

注

Information in the following applications sections is not part of the TI component specification, and TI does not warrant the accuracy or completeness. TI's customers are responsible for determining suitability of components for their purposes. Customers should validate and test their design implementation to confirm system functionality.

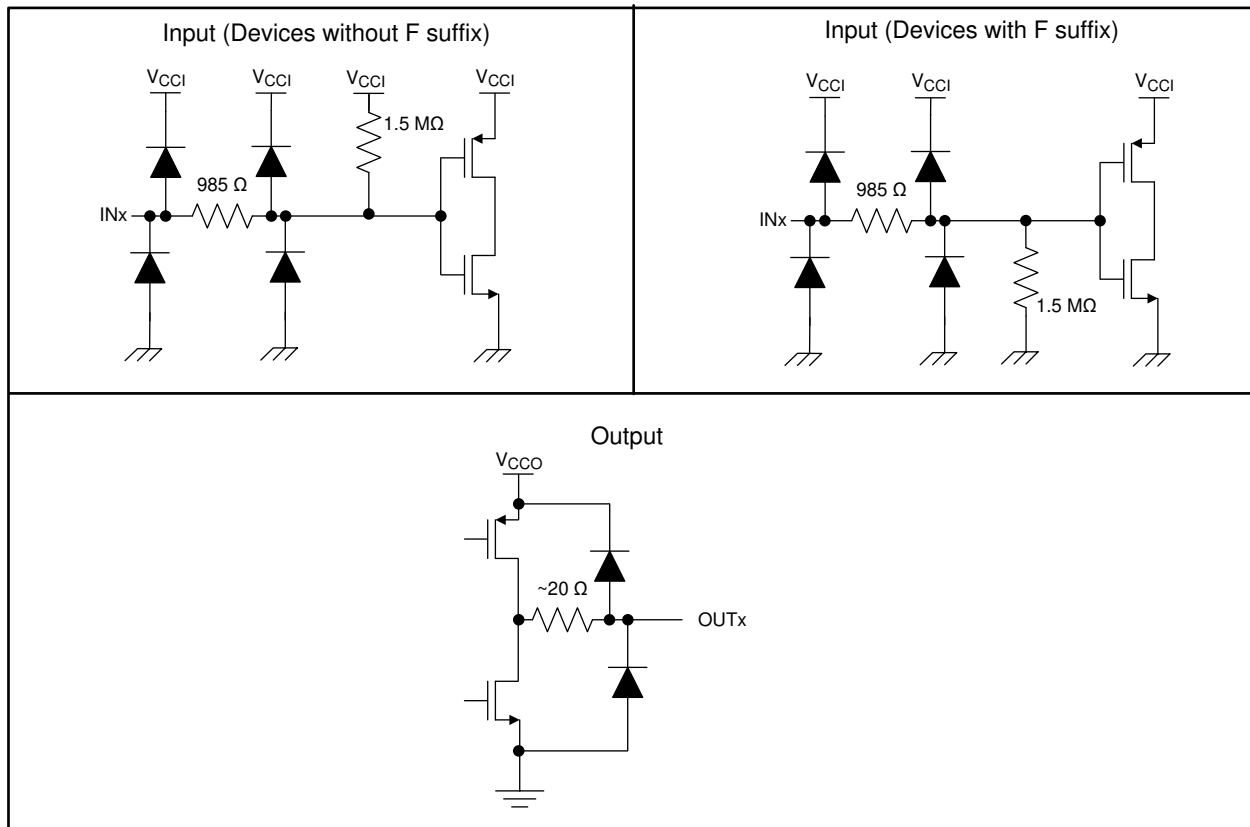
9.1 Application Information

The ISO672xB devices are high-performance, dual-channel digital isolators. The devices use single-ended CMOS-logic switching technology. The supply voltage range is from 1.71 V to 5.5 V for both supplies, V_{CC1} and V_{CC2} . Since an isolation barrier separates the two sides, each side can be sourced independently with any voltage within recommended operating conditions. As an example, it is possible to supply ISO672xB V_{CC1} with 3.3 V (which is within 1.71 V to 1.89 V and 2.25 V to 5 V) and V_{CC2} with 5 V (which is also within 1.71 V to 1.89 V and 2.25 V to 5 V). You can use the digital isolator as a logic-level translator in addition to providing isolation. When designing with digital isolators, keep in mind that because of the single-ended design structure, digital isolators do not conform to any specific interface standard and are only intended for isolating single-ended CMOS or TTL digital signal lines. The isolator is typically placed between the data controller (that is, MCU or FPGA), and a data converter or a line transceiver, regardless of the interface type or standard.

9.2 Typical Application

For industrial applications, the ISO672xB device can be used with Texas Instruments' mixed signal microcontroller, digital-to-analog converter, transformer driver, and voltage regulator to create an isolated 4-mA to 20-mA current loop.

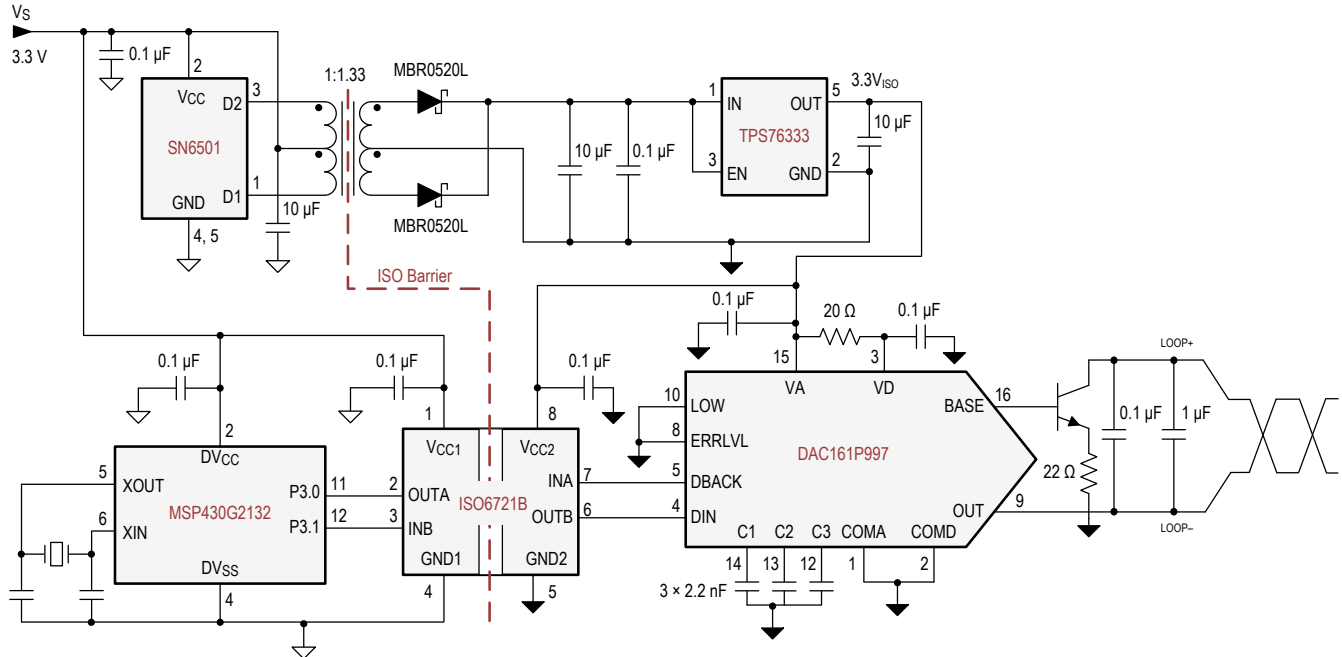

9-1. Isolated 4-mA to 20-mA Current Loop

9.2.1 Design Requirements

To design with these devices, use the parameters listed in [表 9-1](#).

表 9-1. Design Parameters

PARAMETER	VALUE
Supply voltage, V_{CC1} and V_{CC2}	1.71 V to 1.89 V and 2.25 V to 5.5 V
Decoupling capacitor between V_{CC1} and GND1	0.1 μ F
Decoupling capacitor from V_{CC2} and GND2	0.1 μ F

9.2.2 Detailed Design Procedure

Unlike optocouplers, which require external components to improve performance, provide bias, or limit current, the ISO672xB devices only require two external bypass capacitors to operate.



图 9-2. Typical ISO672xB Circuit Hook-up

9.2.3 Application Curve

The following typical eye diagrams of the ISO672xB family of devices indicate low jitter and wide open eye at the maximum data rate of 50 Mbps.

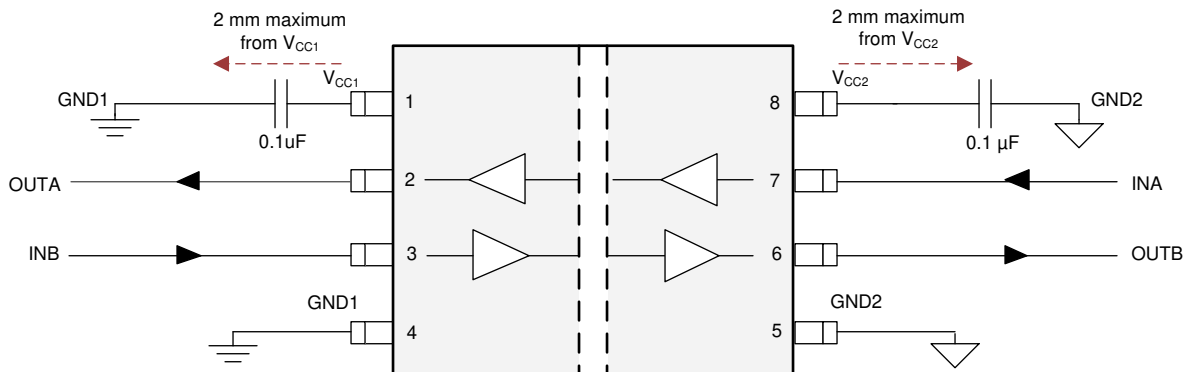
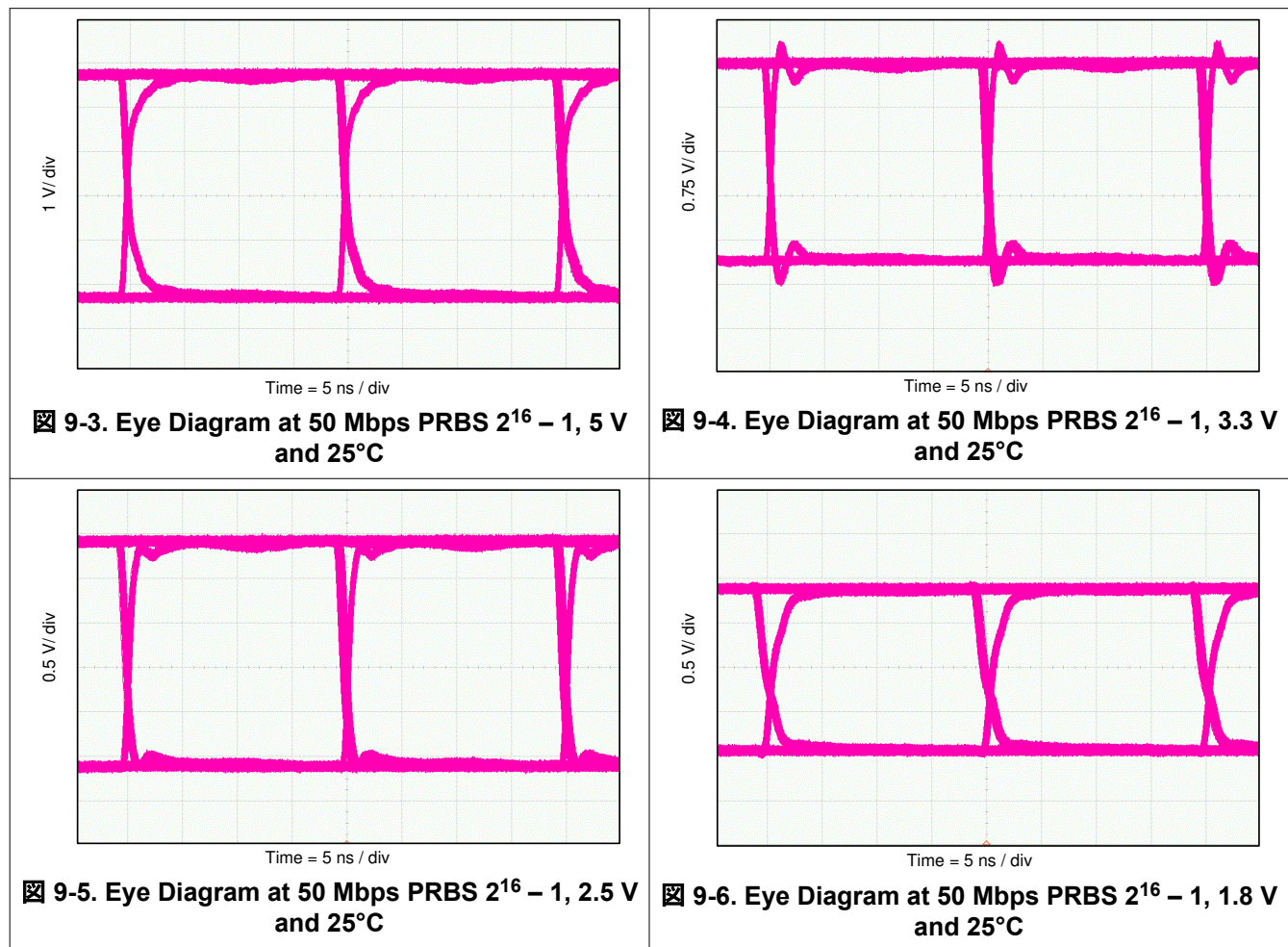

9.3 Insulation Lifetime

Insulation lifetime projection data is collected by using industry-standard Time Dependent Dielectric Breakdown (TDDB) test method. In this test, all pins on each side of the barrier are tied together creating a two-terminal device and high voltage applied between the two sides; See [9-7](#) for TDDB test setup. The insulation breakdown data is collected at various high voltages switching at 60 Hz over temperature. For basic insulation, VDE standard requires the use of TDDB projection line with failure rate of less than 1000 part per million (ppm). For reinforced insulation, VDE standard requires the use of TDDB projection line with failure rate of less than 1 part per million (ppm).

Even though the expected minimum insulation lifetime is 20 years, at the specified working isolation voltage, VDE basic and reinforced certifications require additional safety margin of 20% for working voltage. For basic certification, device lifetime requires a safety margin of 20% translating to a minimum required insulation lifetime of 24 years at a working voltage that is 20% higher than the specified value.

[9-8](#) shows the intrinsic capability of the isolation barrier to withstand high voltage stress over its lifetime. Based on the TDDB data, the intrinsic capability of the insulation is 450 V_{RMS} with a lifetime of >100 years in the 8D package. Other factors, such as package size, pollution degree, material group, etc. can further limit the

working voltage of the component. At the lower working voltages, the corresponding insulation lifetime is much longer than 100 years in the 8-D package.

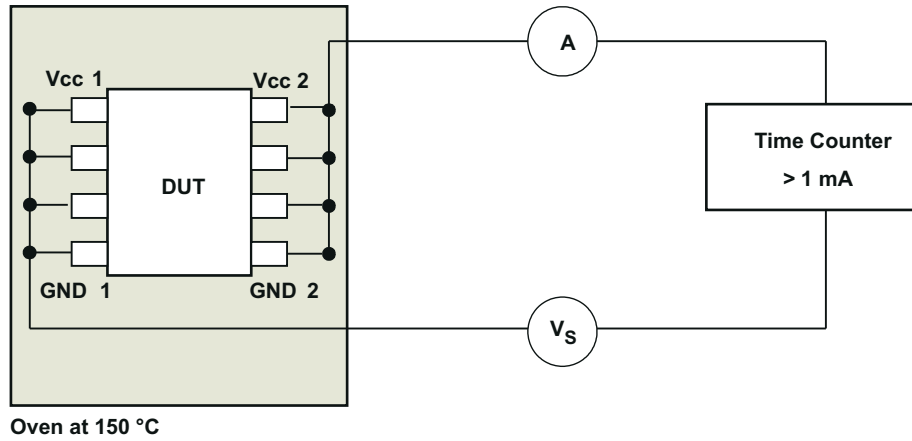

9-7. Test Setup for Insulation Lifetime Measurement

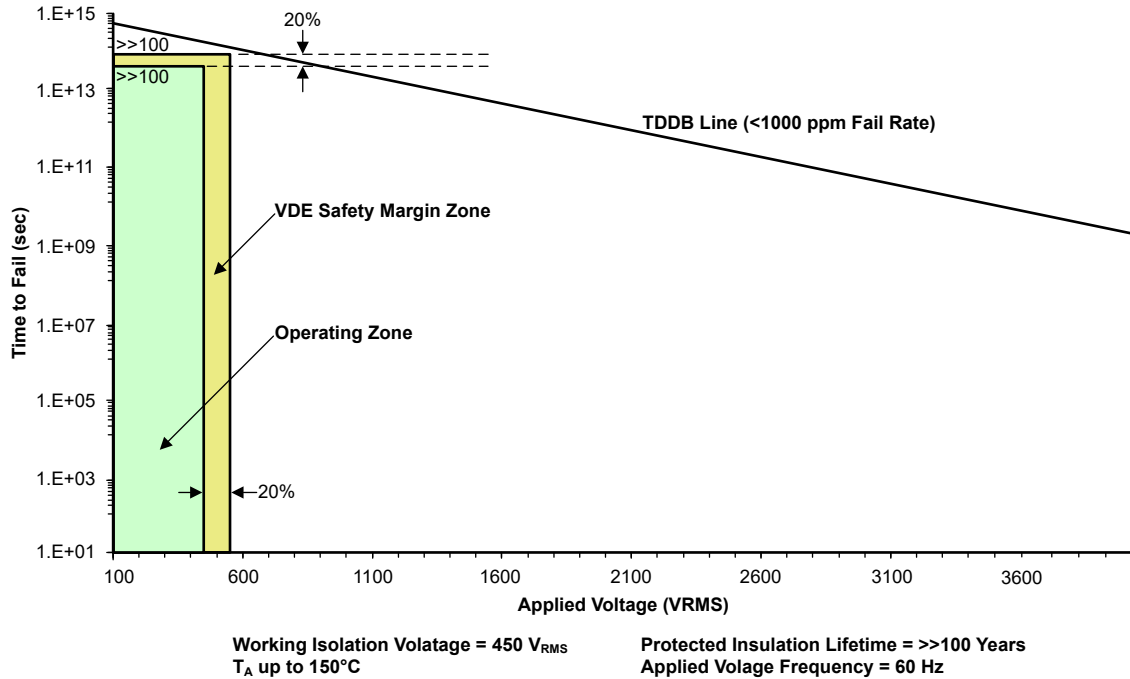

9-8. Insulation Lifetime Projection Data for 8-D Package

10 Power Supply Recommendations

To help ensure reliable operation at data rates and supply voltages, a 0.1- μ F bypass capacitor is recommended at the input and output supply pins (V_{CC1} and V_{CC2}). The capacitors should be placed as close to the supply pins as possible. If only a single primary-side power supply is available in an application, isolated power can be generated for the secondary-side with the help of a transformer driver. For industrial applications, please use Texas Instruments' [SN6501](#) or [SN6505B](#). For such applications, detailed power supply design and transformer selection recommendations are available in [SN6501 Transformer Drivers for Isolated Power Supplies](#) or [SN6505B-Q1 Low-noise, 1-A Transformer Drivers for Isolated Power Supplies](#).

11 Layout

11.1 Layout Guidelines

A minimum of two layers is required to accomplish a cost optimized and low EMI PCB design. To further improve EMI, a four layer board can be used (see [セクション 11.2](#)). Layer stacking for a four layer board should be in the following order (top-to-bottom): high-speed signal layer, ground plane, power plane and low-frequency signal layer.

- Routing the high-speed traces on the top layer avoids the use of vias (and the introduction of their inductances) and allows for clean interconnects between the isolator and the transmitter and receiver circuits of the data link.
- Placing a solid ground plane next to the high-speed signal layer establishes controlled impedance for transmission line interconnects and provides an excellent low-inductance path for the return current flow.
- Placing the power plane next to the ground plane creates additional high-frequency bypass capacitance of approximately 100 pF/in².
- Routing the slower speed control signals on the bottom layer allows for greater flexibility as these signal links usually have margin to tolerate discontinuities such as vias.

If an additional supply voltage plane or signal layer is needed, add a second power or ground plane system to the stack to keep it symmetrical. This makes the stack mechanically stable and prevents it from warping. Also the power and ground plane of each power system can be placed closer together, thus increasing the high-frequency bypass capacitance significantly.

For detailed layout recommendations, refer to the [Digital Isolator Design Guide](#).

11.1.1 PCB Material

For digital circuit boards operating at less than 150 Mbps, (or rise and fall times greater than 1 ns), and trace lengths of up to 10 inches, use standard FR-4 UL94V-0 printed circuit board. This PCB is preferred over cheaper alternatives because of lower dielectric losses at high frequencies, less moisture absorption, greater strength and stiffness, and the self-extinguishing flammability-characteristics.

11.2 Layout Example

Solid supply islands reduce inductance because large peak currents flow into the V_{CC} pin

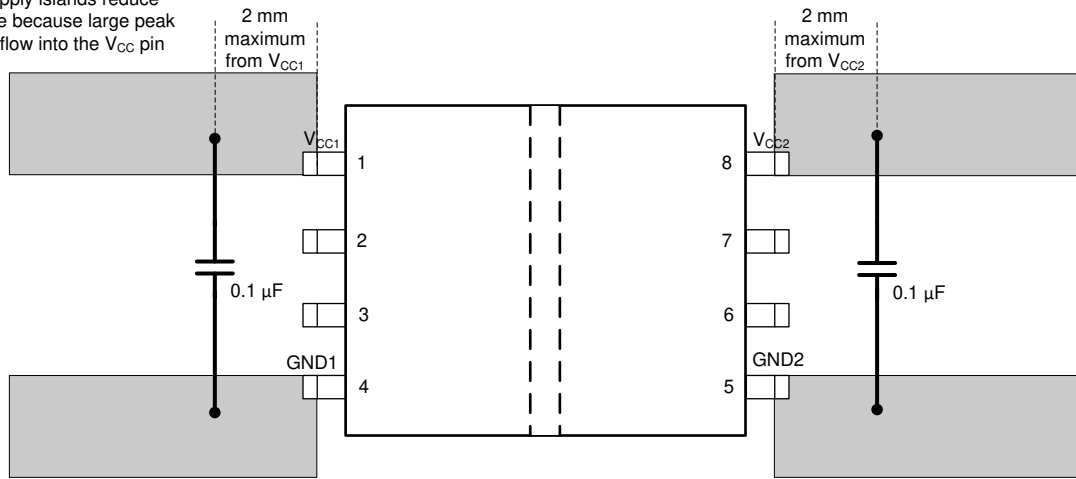

Solid ground islands help dissipate heat through PCB

☒ 11-1. Layout Example

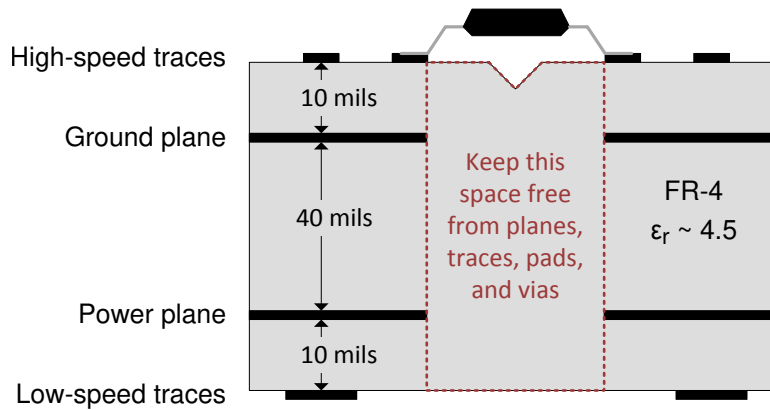

☒ 11-2. Four Layer Board Layout Example

12 Device and Documentation Support

12.1 Device Support

12.1.1 Development Support

For development support, refer to:

- [Isolated CAN Flexible Data \(FD\) Rate Repeater Reference Design](#)
- [Isolated 16-Channel AC Analog Input Module Reference Design Using Dual Simultaneously Sampled ADCs](#)
- [Polyphase Shunt Metrology with Isolated AFE Reference Design](#)
- [Reference Design for Power-Isolated Ultra-Compact Analog Output Module](#)

12.2 Documentation Support

12.2.1 Related Documentation

For related documentation, see the following:

- Texas Instruments, [Digital Isolator Design Guide](#)
- Texas Instruments, [How to use isolation to improve ESD, EFT and Surge immunity in industrial systems application report](#)
- Texas Instruments, [Isolation Glossary](#)
- Texas Instruments, [Enabling high voltage signal isolation quality and reliability](#)
- Texas Instruments, [DAC161P997 Single-Wire 16-bit DAC for 4- to 20-mA Loops data sheet](#)
- Texas Instruments, [MSP430G2132 Mixed Signal Microcontroller data sheet](#)
- Texas Instruments, [SN6501 Transformer Driver for Isolated Power Supplies data sheet](#)
- Texas Instruments, [TPS76333 Low-Power 150-mA Low-Dropout Linear Regulators data sheet](#)

12.3 Receiving Notification of Documentation Updates

To receive notification of documentation updates, navigate to the device product folder on ti.com. In the upper right corner, click on *Alert me* to register and receive a weekly digest of any product information that has changed. For change details, review the revision history included in any revised document.

12.4 サポート・リソース

TI E2E™ サポート・フォーラムは、エンジニアが検証済みの回答と設計に関するヒントをエキスパートから迅速かつ直接得ることができる場所です。既存の回答を検索したり、独自の質問をしたりすることで、設計に必要な支援を迅速に得ることができます。

リンクされているコンテンツは、該当する貢献者により、現状のまま提供されるものです。これらは TI の仕様を構成するものではなく、必ずしも TI の見解を反映したものではありません。TI の [使用条件](#) を参照してください。

12.5 Trademarks

TI E2E™ is a trademark of Texas Instruments.

すべての商標は、それぞれの所有者に帰属します。

12.6 静電気放電に関する注意事項



この IC は、ESD によって破損する可能性があります。テキサス・インスツルメンツは、IC を取り扱う際には常に適切な注意を払うことを推奨します。正しい取り扱いおよび設置手順に従わない場合、デバイスを破損するおそれがあります。

ESD による破損は、わずかな性能低下からデバイスの完全な故障まで多岐にわたります。精密な IC の場合、パラメータがわずかに変化するだけで公表されている仕様から外れる可能性があるため、破損が発生しやすくなっています。

12.7 用語集

[テキサス・インスツルメンツ用語集](#) この用語集には、用語や略語の一覧および定義が記載されています。

13 Mechanical, Packaging, and Orderable Information

The following pages include mechanical packaging and orderable information. This information is the most current data available for the designated devices. This data is subject to change without notice and revision of this document. For browser-based versions of this data sheet, refer to the left-hand navigation.

EXAMPLE STENCIL DESIGN

D0008B

SOIC - 1.75 mm max height

SMALL OUTLINE INTEGRATED CIRCUIT

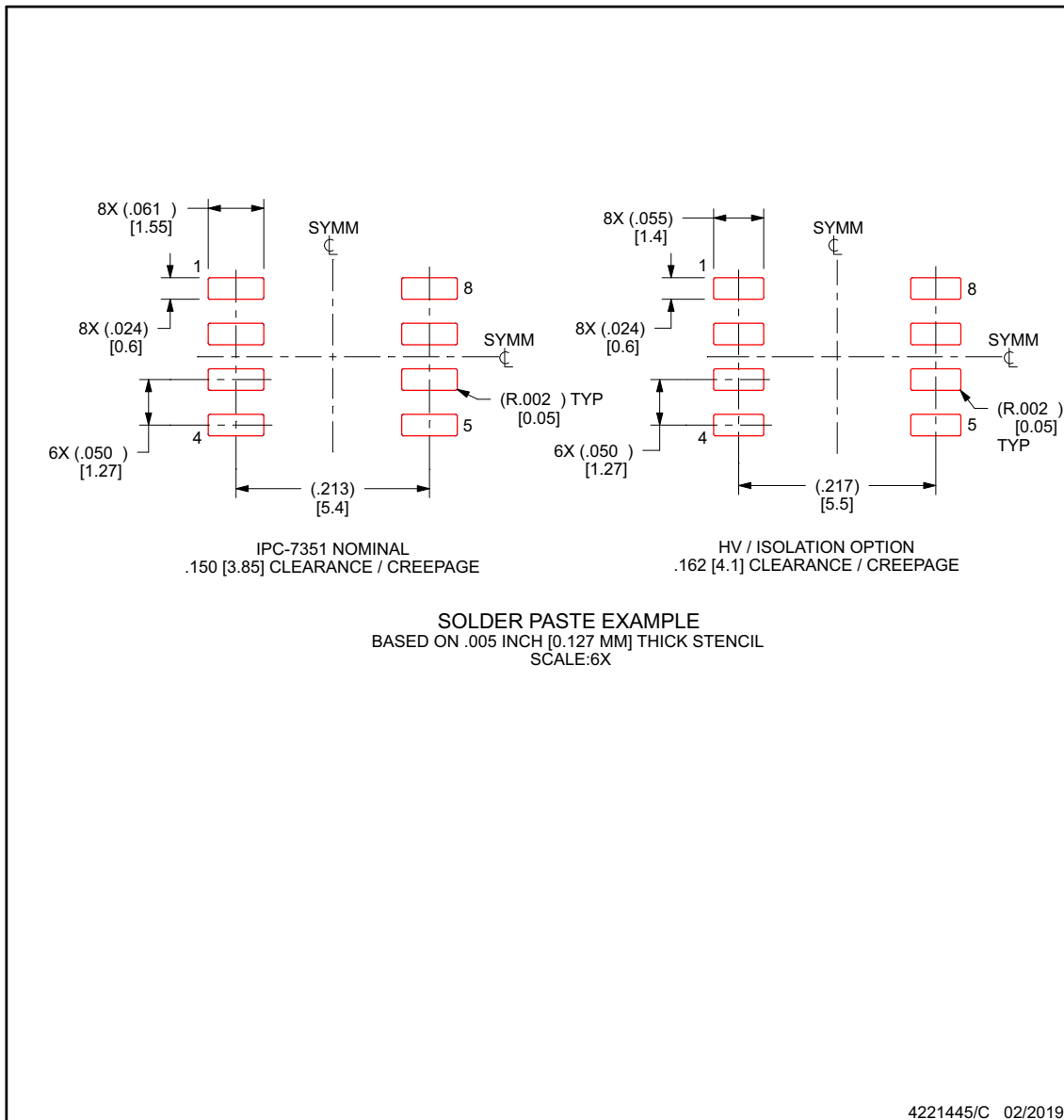

NOTES: (continued)

8. Laser cutting apertures with trapezoidal walls and rounded corners may offer better paste release. IPC-7525 may have alternate design recommendations.
9. Board assembly site may have different recommendations for stencil design.

PACKAGING INFORMATION

Orderable part number	Status (1)	Material type (2)	Package Pins	Package qty Carrier	RoHS (3)	Lead finish/ Ball material (4)	MSL rating/ Peak reflow (5)	Op temp (°C)	Part marking (6)
ISO6720BDR	Active	Production	SOIC (D) 8	3000 LARGE T&R	Yes	NIPDAU	Level-2-260C-1 YEAR	-40 to 125	6720B
ISO6720BDR.A	Active	Production	SOIC (D) 8	3000 LARGE T&R	Yes	NIPDAU	Level-2-260C-1 YEAR	-40 to 125	6720B
ISO6720FBDR	Active	Production	SOIC (D) 8	3000 LARGE T&R	Yes	NIPDAU	Level-2-260C-1 YEAR	-40 to 125	6720FB
ISO6720FBDR.A	Active	Production	SOIC (D) 8	3000 LARGE T&R	Yes	NIPDAU	Level-2-260C-1 YEAR	-40 to 125	6720FB
ISO6721BDR	Active	Production	SOIC (D) 8	3000 LARGE T&R	Yes	NIPDAU	Level-2-260C-1 YEAR	-40 to 125	6721B
ISO6721BDR.A	Active	Production	SOIC (D) 8	3000 LARGE T&R	Yes	NIPDAU	Level-2-260C-1 YEAR	-40 to 125	6721B
ISO6721FBDR	Active	Production	SOIC (D) 8	3000 LARGE T&R	Yes	NIPDAU	Level-2-260C-1 YEAR	-40 to 125	6721FB
ISO6721FBDR.A	Active	Production	SOIC (D) 8	3000 LARGE T&R	Yes	NIPDAU	Level-2-260C-1 YEAR	-40 to 125	6721FB
ISO6721RBDR	Active	Production	SOIC (D) 8	3000 LARGE T&R	Yes	NIPDAU	Level-2-260C-1 YEAR	-40 to 125	21RB
ISO6721RBDR.A	Active	Production	SOIC (D) 8	3000 LARGE T&R	Yes	NIPDAU	Level-2-260C-1 YEAR	-40 to 125	21RB
ISO6721RFBDR	Active	Production	SOIC (D) 8	3000 LARGE T&R	Yes	NIPDAU	Level-2-260C-1 YEAR	-40 to 125	21RFB
ISO6721RFBDR.A	Active	Production	SOIC (D) 8	3000 LARGE T&R	Yes	NIPDAU	Level-2-260C-1 YEAR	-40 to 125	21RFB
ISO6721RFBDRG4	Active	Production	SOIC (D) 8	3000 LARGE T&R	Yes	NIPDAU	Level-2-260C-1 YEAR	-40 to 125	21RFB
ISO6721RFBDRG4.A	Active	Production	SOIC (D) 8	3000 LARGE T&R	Yes	NIPDAU	Level-2-260C-1 YEAR	-40 to 125	21RFB

(1) **Status:** For more details on status, see our [product life cycle](#).

(2) **Material type:** When designated, preproduction parts are prototypes/experimental devices, and are not yet approved or released for full production. Testing and final process, including without limitation quality assurance, reliability performance testing, and/or process qualification, may not yet be complete, and this item is subject to further changes or possible discontinuation. If available for ordering, purchases will be subject to an additional waiver at checkout, and are intended for early internal evaluation purposes only. These items are sold without warranties of any kind.

(3) **RoHS values:** Yes, No, RoHS Exempt. See the [TI RoHS Statement](#) for additional information and value definition.

(4) **Lead finish/Ball material:** Parts may have multiple material finish options. Finish options are separated by a vertical ruled line. Lead finish/Ball material values may wrap to two lines if the finish value exceeds the maximum column width.

(5) **MSL rating/Peak reflow:** The moisture sensitivity level ratings and peak solder (reflow) temperatures. In the event that a part has multiple moisture sensitivity ratings, only the lowest level per JEDEC standards is shown. Refer to the shipping label for the actual reflow temperature that will be used to mount the part to the printed circuit board.

(6) **Part marking:** There may be an additional marking, which relates to the logo, the lot trace code information, or the environmental category of the part.

Multiple part markings will be inside parentheses. Only one part marking contained in parentheses and separated by a "~" will appear on a part. If a line is indented then it is a continuation of the previous line and the two combined represent the entire part marking for that device.

Important Information and Disclaimer: The information provided on this page represents TI's knowledge and belief as of the date that it is provided. TI bases its knowledge and belief on information provided by third parties, and makes no representation or warranty as to the accuracy of such information. Efforts are underway to better integrate information from third parties. TI has taken and continues to take reasonable steps to provide representative and accurate information but may not have conducted destructive testing or chemical analysis on incoming materials and chemicals. TI and TI suppliers consider certain information to be proprietary, and thus CAS numbers and other limited information may not be available for release.

In no event shall TI's liability arising out of such information exceed the total purchase price of the TI part(s) at issue in this document sold by TI to Customer on an annual basis.

OTHER QUALIFIED VERSIONS OF ISO6720, ISO6721, ISO6721R :

- Automotive : [ISO6720-Q1](#), [ISO6721-Q1](#), [ISO6721R-Q1](#)

NOTE: Qualified Version Definitions:

- Automotive - Q100 devices qualified for high-reliability automotive applications targeting zero defects

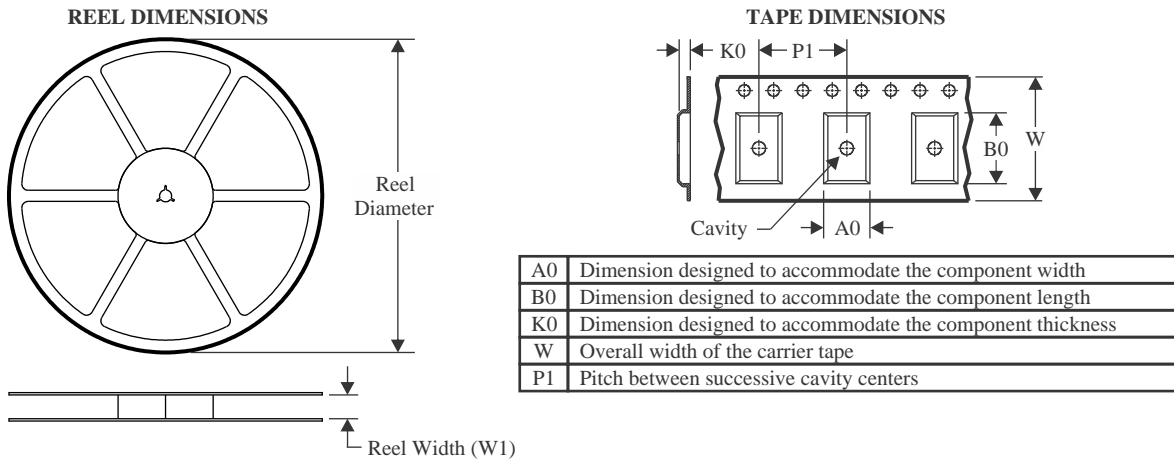
TAPE AND REEL INFORMATION

QUADRANT ASSIGNMENTS FOR PIN 1 ORIENTATION IN TAPE

*All dimensions are nominal

Device	Package Type	Package Drawing	Pins	SPQ	Reel Diameter (mm)	Reel Width W1 (mm)	A0 (mm)	B0 (mm)	K0 (mm)	P1 (mm)	W (mm)	Pin1 Quadrant
ISO6720BDR	SOIC	D	8	3000	330.0	12.4	6.5	5.4	2.0	8.0	12.0	Q1
ISO6720FBDR	SOIC	D	8	3000	330.0	12.4	6.5	5.4	2.0	8.0	12.0	Q1
ISO6721BDR	SOIC	D	8	3000	330.0	12.4	6.5	5.4	2.0	8.0	12.0	Q1
ISO6721BDR	SOIC	D	8	3000	330.0	12.4	6.4	5.2	2.1	8.0	12.0	Q1
ISO6721FBDR	SOIC	D	8	3000	330.0	12.4	6.5	5.4	2.0	8.0	12.0	Q1
ISO6721RBDR	SOIC	D	8	3000	330.0	12.4	6.5	5.4	2.0	8.0	12.0	Q1
ISO6721RBDR	SOIC	D	8	3000	330.0	12.4	6.4	5.2	2.1	8.0	12.0	Q1
ISO6721RFBDR	SOIC	D	8	3000	330.0	12.4	6.5	5.4	2.0	8.0	12.0	Q1
ISO6721RFBDRG4	SOIC	D	8	3000	330.0	12.4	6.5	5.4	2.0	8.0	12.0	Q1

TAPE AND REEL BOX DIMENSIONS

*All dimensions are nominal

Device	Package Type	Package Drawing	Pins	SPQ	Length (mm)	Width (mm)	Height (mm)
ISO6720BDR	SOIC	D	8	3000	356.0	356.0	36.0
ISO6720FBDR	SOIC	D	8	3000	356.0	356.0	36.0
ISO6721BDR	SOIC	D	8	3000	356.0	356.0	36.0
ISO6721BDR	SOIC	D	8	3000	353.0	353.0	32.0
ISO6721FBDR	SOIC	D	8	3000	356.0	356.0	36.0
ISO6721RBDR	SOIC	D	8	3000	356.0	356.0	36.0
ISO6721RBDR	SOIC	D	8	3000	353.0	353.0	32.0
ISO6721RFBDR	SOIC	D	8	3000	356.0	356.0	36.0
ISO6721RFBDRG4	SOIC	D	8	3000	356.0	356.0	36.0



D0008A

PACKAGE OUTLINE

SOIC - 1.75 mm max height

SMALL OUTLINE INTEGRATED CIRCUIT



4214825/C 02/2019

NOTES:

- Linear dimensions are in inches [millimeters]. Dimensions in parenthesis are for reference only. Controlling dimensions are in inches. Dimensioning and tolerancing per ASME Y14.5M.
- This drawing is subject to change without notice.
- This dimension does not include mold flash, protrusions, or gate burrs. Mold flash, protrusions, or gate burrs shall not exceed $.006$ [0.15] per side.
- This dimension does not include interlead flash.
- Reference JEDEC registration MS-012, variation AA.

EXAMPLE BOARD LAYOUT

D0008A

SOIC - 1.75 mm max height

SMALL OUTLINE INTEGRATED CIRCUIT



LAND PATTERN EXAMPLE
EXPOSED METAL SHOWN
SCALE:8X



SOLDER MASK DETAILS

4214825/C 02/2019

NOTES: (continued)

- 6. Publication IPC-7351 may have alternate designs.
- 7. Solder mask tolerances between and around signal pads can vary based on board fabrication site.

EXAMPLE STENCIL DESIGN

D0008A

SOIC - 1.75 mm max height

SMALL OUTLINE INTEGRATED CIRCUIT



SOLDER PASTE EXAMPLE
BASED ON .005 INCH [0.125 MM] THICK STENCIL
SCALE:8X

4214825/C 02/2019

NOTES: (continued)

8. Laser cutting apertures with trapezoidal walls and rounded corners may offer better paste release. IPC-7525 may have alternate design recommendations.
9. Board assembly site may have different recommendations for stencil design.

重要なお知らせと免責事項

TI は、技術データと信頼性データ (データシートを含みます)、設計リソース (リファレンス デザインを含みます)、アプリケーションや設計に関する各種アドバイス、Web ツール、安全性情報、その他のリソースを、欠陥が存在する可能性のある「現状のまま」提供しており、商品性および特定目的に対する適合性の黙示保証、第三者の知的財産権の非侵害保証を含むいかなる保証も、明示的または黙示的にかかわらず拒否します。

これらのリソースは、TI 製品を使用する設計の経験を積んだ開発者への提供を意図したものです。(1) お客様のアプリケーションに適した TI 製品の選定、(2) お客様のアプリケーションの設計、検証、試験、(3) お客様のアプリケーションに該当する各種規格や、その他のあらゆる安全性、セキュリティ、規制、または他の要件への確実な適合に関する責任を、お客様のみが単独で負うものとし、

上記の各種リソースは、予告なく変更される可能性があります。これらのリソースは、リソースで説明されている TI 製品を使用するアプリケーションの開発の目的でのみ、TI はその使用をお客様に許諾します。これらのリソースに関して、他の目的で複製することや掲載することは禁止されています。TI や第三者の知的財産権のライセンスが付与されている訳ではありません。お客様は、これらのリソースを自身で使用した結果発生するあらゆる申し立て、損害、費用、損失、責任について、TI およびその代理人を完全に補償するものとし、TI は一切の責任を拒否します。

TI の製品は、[TI の販売条件](#)、[TI の総合的な品質ガイドライン](#)、[ti.com](#) または TI 製品などに関連して提供される他の適用条件に従い提供されます。TI がこれらのリソースを提供することは、適用される TI の保証または他の保証の放棄の拡大や変更を意味するものではありません。TI がカスタム、またはカスタマー仕様として明示的に指定していない限り、TI の製品は標準的なカタログに掲載される汎用機器です。

お客様がいかなる追加条項または代替条項を提案する場合も、TI はそれらに異議を唱え、拒否します。

Copyright © 2026, Texas Instruments Incorporated

最終更新日 : 2025 年 10 月