

LMK1C110x 1.8V、2.5V、3.3V LVCMOS クロック・バッファ・ファミリ

1 特長

- 高性能の 1:2、1:3、1:4 LVCMOS クロック・バッファ
- 非常に小さい出力スキュー: 50ps 未満
- 非常に小さい付加ジッタ: 50fs 未満
 - $V_{DD} = 3.3V$ で 7.5fs (標準値)
 - $V_{DD} = 2.5V$ で 10fs (標準値)
 - $V_{DD} = 1.8V$ で 19.2fs (標準値)
- 超低速伝播遅延: 3ns 未満
- 同期出力イネーブル
- 電源電圧: 3.3V、2.5V、1.8V
 - 3.3V トレラント入力機能 (すべての電源電圧で対応)
 - フェイルセーフ入力
- 3.3V で $f_{max} = 250MHz$
2.5V および 1.8V で $f_{max} = 200MHz$
- 動作温度範囲: $-40^{\circ}C \sim 125^{\circ}C$
- 8 ピンの TSSOP パッケージで供給
- 8 ピンの WSON パッケージで供給

2 アプリケーション

- ファクトリ・オートメーション / 制御
- 通信機器
- データ・センターおよびエンタープライズ・コンピューティング
- グリッド・インフラストラクチャ
- モーター・ドライブ
- 医療用画像処理

3 概要

LMK1C110x は、テキサス・インスツルメンツ製の高性能、低スキューのモジュール式汎用クロック・バッファ・ファミリです。このファミリはすべて、モジュール手法を考慮して設計されています。1:2、1:3、1:4 の 3 種類のファンアウト・バリエーションがあります。

このファミリに属するデバイスはすべて互いにピン互換であり、CDCLVC110x ファミリと後方互換性があるため扱いが簡単です。

ファミリのすべての製品は、小さい付加ジッタ、小さいスキュー、広い動作温度範囲などの高い性能を共有しています。

LMK1C110x は、1G が LOW になると出力を LOW 状態に切り換える同期出力イネーブル制御 (1G) をサポートしています。これらのデバイスにはフェイルセーフ入力があり、入力信号がない場合の出力の発振を防止し、VDD が供給される前に入力信号を受け入れます。

LMK1C110x ファミリは 1.8V、2.5V、3.3V 環境で動作し、 $-40^{\circ}C \sim 125^{\circ}C$ で動作が規定されています。

製品情報⁽¹⁾

部品番号	パッケージ	本体サイズ (公称)
LMK1C1102	TSSOP (8)	3.00mm × 4.40mm
LMK1C1103		
LMK1C1104		
LMK1C1102	WSON (8)	2.00mm × 2.00mm
LMK1C1104		

- (1) 利用可能なパッケージについては、このデータシートの末尾にある注文情報を参照してください。

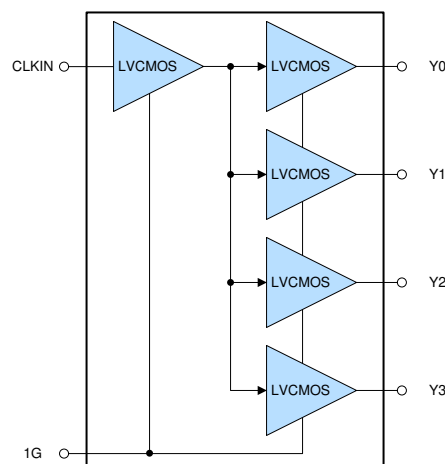

機能ブロック図



Table of Contents

1 特長	1	9.3 Feature Description.....	10
2 アプリケーション	1	9.4 Device Functional Modes.....	10
3 概要	1	10 Application and Implementation	11
4 Revision History	2	10.1 Application Information.....	11
5 Device Comparison	3	10.2 Typical Application.....	11
6 Pin Configuration and Functions	3	11 Power Supply Recommendations	13
7 Specifications	5	12 Layout	14
7.1 Absolute Maximum Ratings.....	5	12.1 Layout Guidelines.....	14
7.2 ESD Ratings.....	5	12.2 Layout Example.....	14
7.3 Recommended Operating Conditions.....	5	13 Device and Documentation Support	15
7.4 Thermal Information.....	5	13.1 Receiving Notification of Documentation Updates..	15
7.5 Electrical Characteristics.....	6	13.2 サポート・リソース.....	15
7.6 Timing Requirements.....	7	13.3 Trademarks.....	15
7.7 Typical Characteristics.....	7	13.4 Electrostatic Discharge Caution.....	15
8 Parameter Measurement Information	8	13.5 Glossary.....	15
9 Detailed Description	10	14 Mechanical, Packaging, and Orderable Information	15
9.1 Overview.....	10		
9.2 Functional Block Diagram.....	10		

4 Revision History

Changes from Revision C (June 2021) to Revision D (February 2022)	Page
• 「概要」セクションにフェイルセーフ入力の詳細を追加.....	1
• Changed part-to-part skew maximum from 450 ps to 250 ps.....	6
• Added the <i>Fail-Safe Inputs</i> section.....	10

Changes from Revision B (June 2020) to Revision C (June 2021)	Page
• 文書全体にわたってテキスト形式、表、図、相互参照の採番方法を変更.....	1
• LMK1C1102/04 DQF (WSON) パッケージを追加.....	1
• Added the <i>Device Comparison</i> table.....	3
• Added pinout diagrams for the DQF (WSON) package variant of the LMK1C1102 and LMK1C1104.....	3
• Added information pertaining to the layout of LMK1C1102/04 WSON package variant.....	14
• Removed <i>Related Links</i> section.....	15

Changes from Revision A (February 2020) to Revision B (June 2020)	Page
• 「概要」セクションにファンアウト・バリエーションの情報を追加.....	1
• 先頭ページから LMK1C1104PW のピン配置を削除.....	1
• Added LMK1C1102 and LMK1C1103 pinout diagrams.....	3

Changes from Revision * (December 2019) to Revision A (February 2020)	Page
• データシートに LMK1C1102 と LMK1C1103 を追加.....	1
• Changed the <i>Power Supply Recommendations</i> section.....	13

5 Device Comparison

表 5-1. Device Comparison

DEVICE	NUMBER OF OUTPUTS	PACKAGE
LMK1C1102	2	TSSOP (8), 3.00 mm x 4.40 mm
LMK1C1103	3	
LMK1C1104	4	
LMK1C1106	6	TSSOP (14), 5.00 mm x 4.40 mm
LMK1C1108	8	TSSOP (16), 5.00 mm x 4.40 mm
LMK1C1102	2	WSON (8), 2.00 mm x 2.00 mm
LMK1C1104	4	

6 Pin Configuration and Functions



图 6-1. LMK1C1102 PW Package 8-Pin TSSOP Top View



1. The DQF (WSON) package is equivalent to the DFN package of other vendors.

图 6-2. LMK1C1102 DQF Package 8-Pin WSON Top View

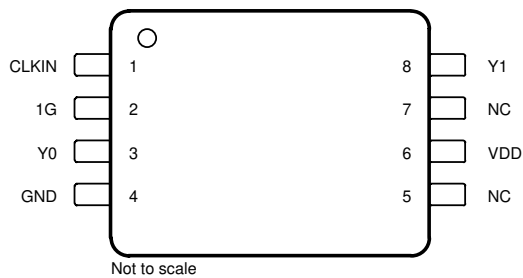
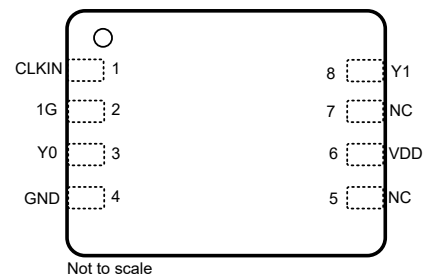

图 6-3. LMK1C1103 PW Package 8-Pin TSSOP Top View



图 6-4. LMK1C1104 PW Package 8-Pin TSSOP Top View

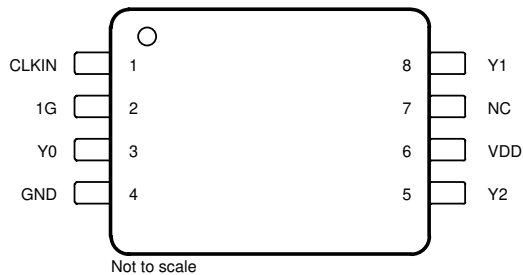

1. The DQF (WSON) package is equivalent to the DFN package of other vendors.

图 6-5. LMK1C1104 DQF Package 8-Pin WSON Top View

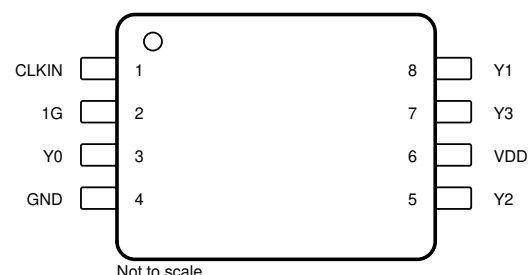
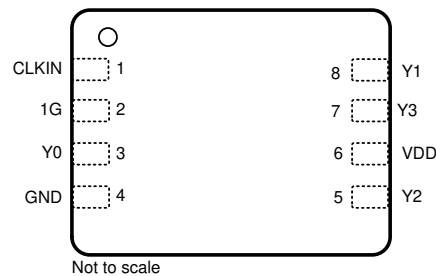
表 6-1. Pin Functions

NAME	PIN			TYPE	DESCRIPTION
	LMK1C 1102	LMK1C 1103	LMK1C 1104		
LVC MOS CLOCK INPUT					
CLKIN	1	1	1	Input	Single-ended clock input with internal 300-kΩ (typical) pulldown resistor to GND. Typically connected to a single-ended clock input.
CLOCK OUTPUT ENABLE					
1G	2	2	2	Input	Global Output Enable with internal 300-kΩ (typical) pulldown resistor to GND. Typically connected to VDD with external pullup resistor. HIGH: outputs enabled LOW: outputs disabled
LVC MOS CLOCK OUTPUT					
Y0	3	3	3	Output	LVC MOS output. Typically connected to a receiver. Unused outputs can be left floating.
Y1	8	8	8		
Y2	—	5	5		
Y3	—	—	7		
SUPPLY VOLTAGE					
VDD	6	6	6	Power	Power supply terminal. Typically connected to a 3.3-V, 2.5-V, or 1.8-V supply. The VDD pin is typically connected to an external 0.1-μF capacitor near the pin.
GROUND					
GND	4	4	4	GND	Power supply ground.

7 Specifications

7.1 Absolute Maximum Ratings

over operating free-air temperature range (unless otherwise noted)⁽¹⁾

		MIN	MAX	UNIT
V _{DD}	Supply voltage	-0.5	3.6	V
V _{CLKIN}	Input voltage (CLKIN)			
V _{IN}	Input voltage (1G)			
V _{Yn}	Output pins (Yn)	-0.5	V _{DD} + 0.3	
I _{IN}	Input current	-20	20	mA
I _O	Continuous output current	-50	50	mA
T _{stg}	Storage temperature	-65	150	°C

- (1) Operation outside the *Absolute Maximum Ratings* may cause permanent device damage. *Absolute Maximum Ratings* do not imply functional operation of the device at these or any other conditions beyond those listed under *Recommended Operating Conditions*. If used outside the *Recommended Operating Conditions* but within the *Absolute Maximum Ratings*, the device may not be fully functional, and this may affect device reliability, functionality, performance, and shorten the device lifetime.

7.2 ESD Ratings

			VALUE	UNIT
V _(ESD)	Electrostatic discharge	Human body model (HBM), per ANSI/ESDA/ JEDEC JS-001, all pins ⁽¹⁾	±9000	V
		Charged device model (CDM), per JEDEC specification JESD22-C101, all pins ⁽²⁾	±1500	

- (1) JEDEC document JEP155 states that 500-V HBM allows safe manufacturing with a standard ESD control process.
(2) JEDEC document JEP157 states that 250-V CDM allows safe manufacturing with a standard ESD control process.

7.3 Recommended Operating Conditions

over operating free-air temperature range (unless otherwise noted)

			MIN	NOM	MAX	UNIT
V _{DD}	Core supply voltage	3.3-V supply	3.135	3.3	3.465	V
		2.5-V supply	2.375	2.5	2.625	
		1.8-V supply	1.71	1.8	1.89	
T _A	Operating free-air temperature		-40		125	°C
T _J	Operating junction temperature		-40		150	°C

7.4 Thermal Information

THERMAL METRIC ⁽¹⁾		LMK1C1104		UNIT
		DQF(WSON)	PW (TSSOP)	
		8 PINS	8 PINS	
R _{qJA}	Junction-to-ambient thermal resistance	163	181.9	°C/W
R _{qJC(top)}	Junction-to-case (top) thermal resistance	105.7	76.6	°C/W
R _{qJB}	Junction-to-board thermal resistance	84.2	111.6	°C/W
Y _{JT}	Junction-to-top characterization parameter	16.7	16	°C/W
Y _{JB}	Junction-to-board characterization parameter	83.9	110.1	°C/W

- (1) For more information about traditional and new thermal metrics, see the [Semiconductor and IC Package Thermal Metrics](#) application report.

7.5 Electrical Characteristics

VDD = 3.3 V ± 5 %, -40°C ≤ TA ≤ 125°C. Typical values are at VDD = 3.3 V, 25°C (unless otherwise noted)

PARAMETER		TEST CONDITIONS	MIN	TYP	MAX	UNIT
CURRENT CONSUMPTION						
I _{DD}	Core supply current, static	All-outputs disabled, f _{IN} = 0 V		25	45	μA
I _{DD}	Core supply current	All-outputs disabled, f _{IN} = 100 MHz		8	15	mA
		All-outputs active, f _{IN} = 100 MHz, C _L = 5pF, V _{DD} = 1.8 V		14	20	
		All-outputs active, f _{IN} = 100 MHz, C _L = 5pF, V _{DD} = 2.5 V		21	30	
		All-outputs active, f _{IN} = 100 MHz, C _L = 5pF, V _{DD} = 3.3 V		33	40	
CLOCK INPUT						
f _{IN_SE}	Input frequency	V _{DD} = 3.3 V	DC		250	MHz
		V _{DD} = 2.5 V and 1.8 V	DC		200	
V _{IH}	Input high voltage		0.7 x V _{DD}			V
V _{IL}	Input low voltage				0.3 x V _{DD}	
dV _{IN} /dt	Input slew rate	20% - 80% of input swing	0.1			V/ns
I _{IN_LEAK}	Input leakage current		-50		50	uA
C _{IN_SE}	Input capacitance	at 25°C		7		pF
CLOCK OUTPUT FOR ALL V_{DD} LEVELS						
f _{OUT}	Output frequency	V _{DD} = 3.3 V			250	MHz
		V _{DD} = 2.5 V and 1.8 V			200	
ODC	Output duty cycle	With 50% duty cycle input (for all VDD)	45		55	%
t _{START}	Start-up time before output is active	See (1)			3	ms
t _{1G_ON}	Output enable time	See (2)			5	cycles
t _{1G_OFF}	Output disable time	See (3)			5	cycles
CLOCK OUTPUT FOR V_{DD} = 3.3 V ± 5%						
V _{OH}	Output high voltage	I _{OH} = 1 mA	2.8			V
V _{OL}	Output low voltage	I _{OL} = 1 mA			0.2	
t _{RISE-FALL}	Output rise and fall time	20/80%, C _L = 5 pF, f _{IN} = 156.25 MHz		0.35	0.7	ns
t _{OUTPUT-SKEW}	Output-output skew	See (4)		25	50	ps
t _{PART-SKEW}	Part-to-part skew				250	
t _{PROP-DELAY}	Propagation delay	See (5)		1.5	2	ns
t _{JITTER-ADD}	Additive Jitter	f _{IN} = 156.25 MHz, Input slew rate = 2 V/ns, Integration range = 12 kHz - 20 MHz		8	20	fs, RMS
R _{OUT}	Output impedance			50		Ω
CLOCK OUTPUT FOR V_{DD} = 2.5 V ± 5%						
V _{OH}	Output high voltage	I _{OH} = 1 mA	0.8 x V _{DD}			V
V _{OL}	Output low voltage	I _{OL} = 1 mA			0.2 x V _{DD}	
t _{RISE-FALL}	Output rise and fall time	20/80%, C _L = 5 pF, f _{IN} = 156.25 MHz		0.33	0.8	ns
t _{OUTPUT-SKEW}	Output-output skew	See (4)			50	ps
t _{PART-SKEW}	Part-to-part skew				400	
t _{PROP-DELAY}	Propagation delay	See (5)		1.5	2.5	ns
t _{JITTER-ADD}	Additive Jitter	f _{IN} = 156.25 MHz, Input slew rate = 2 V/ns, Integration range = 12 kHz - 20 MHz		11	27	fs, RMS
R _{OUT}	Output impedance			52.5		Ω

VDD = 3.3 V ± 5 %, -40°C ≤ TA ≤ 125°C. Typical values are at VDD = 3.3 V, 25°C (unless otherwise noted)

PARAMETER		TEST CONDITIONS	MIN	TYP	MAX	UNIT
CLOCK OUTPUT FOR VDD = 1.8 V ± 5%						
V _{OH}	Output high voltage	I _{OH} = 1 mA	0.8 x V _{DD}			V
V _{OL}	Output low voltage	I _{OL} = 1 mA	0.2 x V _{DD}			
t _{RISE-FALL}	Output rise and fall time	20/80%, C _L = 5 pF, f _{IN} = 156.25 MHz		0.38	1	ns
t _{OUTPUT-SKEW}	Output-output skew	See (4)			50	ps
t _{PART-SKEW}	Part-to-part skew				900	ps
t _{PROP-DELAY}	Propagation delay	See (5)		1.5	3	ns
t _{JITTER-ADD}	Additive Jitter	f _{IN} = 156.25 MHz, Input slew rate = 2 V/ns, Integration range = 12 kHz - 20 MHz		17.5	50	fs, RMS
R _{OUT}	Output impedance			60		Ω
GENERAL PURPOSE INPUT (1G)						
V _{IH}	High-level input voltage		0.75 x V _{DD}			V
V _{IL}	Low-level input voltage		0.25 x V _{DD}			
I _{IH}	Input high-level current	V _{IH} = V _{DD_REF}	-50		50	μA
I _{IL}	Input low-level current	V _{IL} = GND	-50		50	

- (1) Measured from VDD stable to output active, when 1G = HIGH.
- (2) Measured from 1G rising edge crossing V_{IH} to first rising edge of Y_n.
- (3) Measured from 1G falling edge crossing V_{IL} to last falling edge of Y_n.
- (4) Measured from rising edge of any Y_n output to any other Y_m output.
- (5) Measured from rising edge of CLKIN to any Y_n output.

7.6 Timing Requirements

VDD = 3.3 V ± 5 %, -40°C ≤ TA ≤ 125°C

		MIN	NOM	MAX	UNIT
POWER SUPPLY					
V/t _{RAMP}	V _{DD} ramp rate	0.1		50	V/ms

7.7 Typical Characteristics

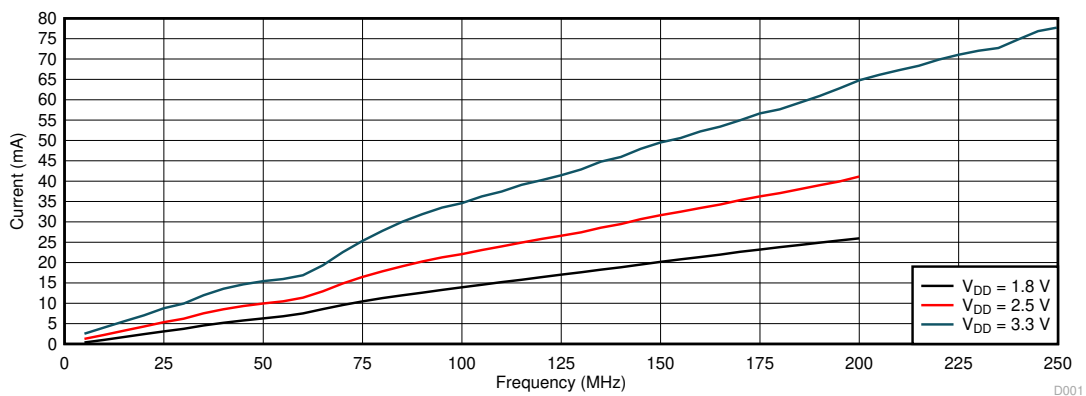

7-1. Device Power Consumption vs. Clock Frequency (Load 5 pF)

8 Parameter Measurement Information

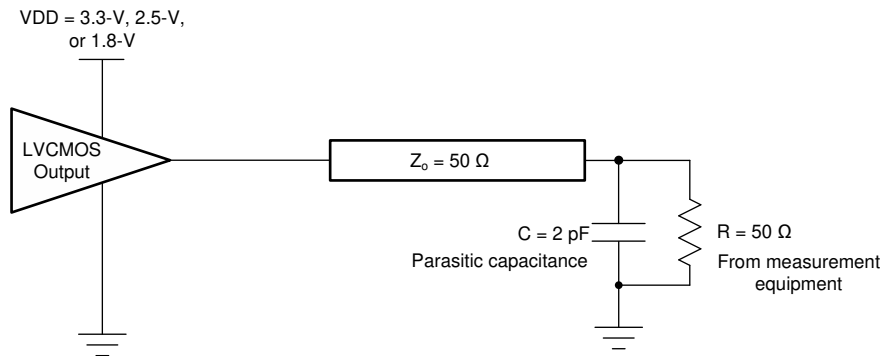

8-1. Test Load Circuit

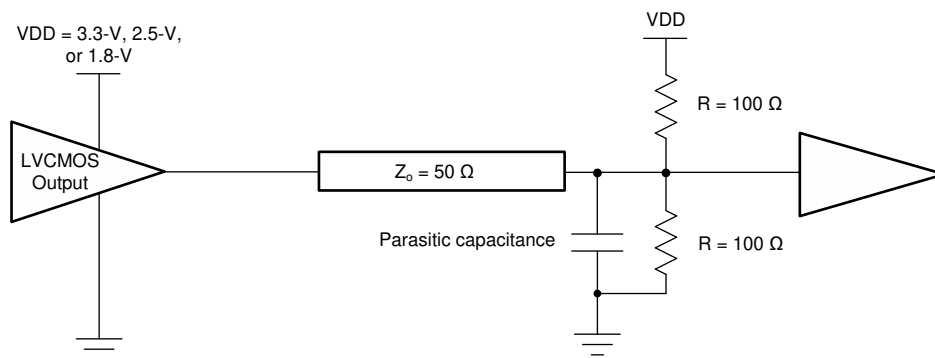

8-2. Application Load With 50- Ω Termination

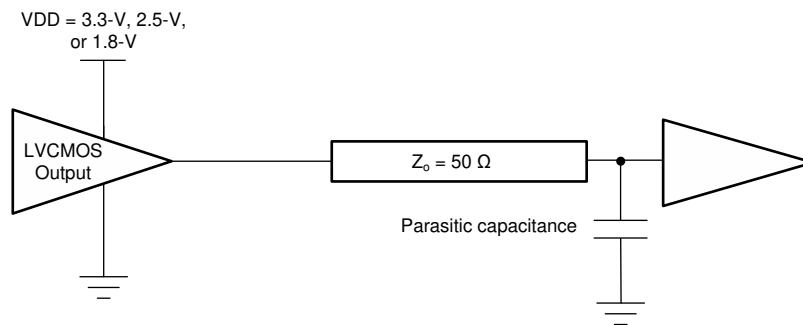

8-3. Application Load With Termination

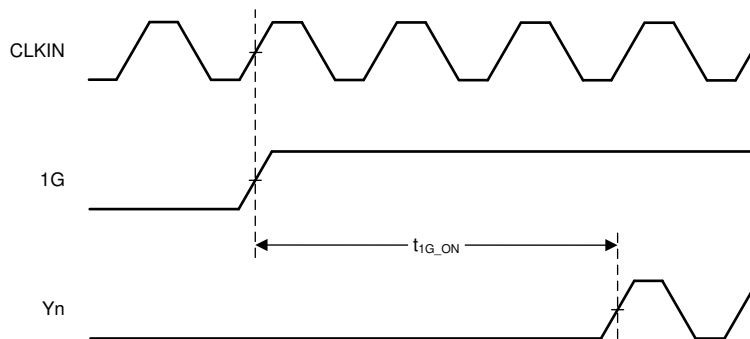

8-4. t_{1G_ON} Output Enable Time

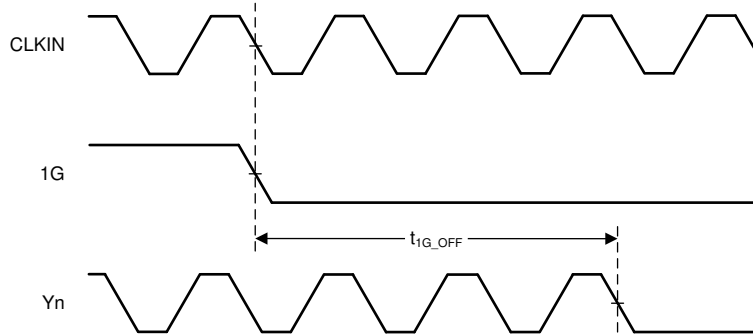

8-5. t_{1G_OFF} Output Disable Time

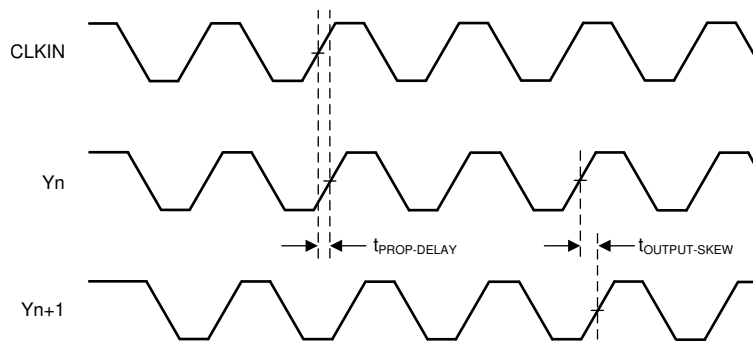

8-6. Propagation Delay t_{PROP_DELAY} and Output Skew t_{OUTPUT_SKEW}

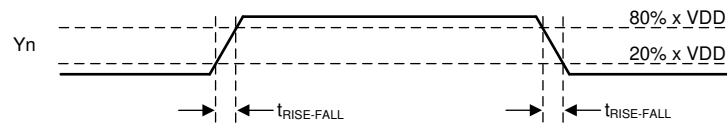

8-7. Rise and Fall Time $t_{RISE-FALL}$

9 Detailed Description

9.1 Overview

The LMK1C110x family of devices is part of a low-jitter and low-skew LVCMOS fan-out buffer solution. For best signal integrity, it is important to match the characteristic impedance of the LMK1C110x's output driver with that of the transmission line.

9.2 Functional Block Diagram

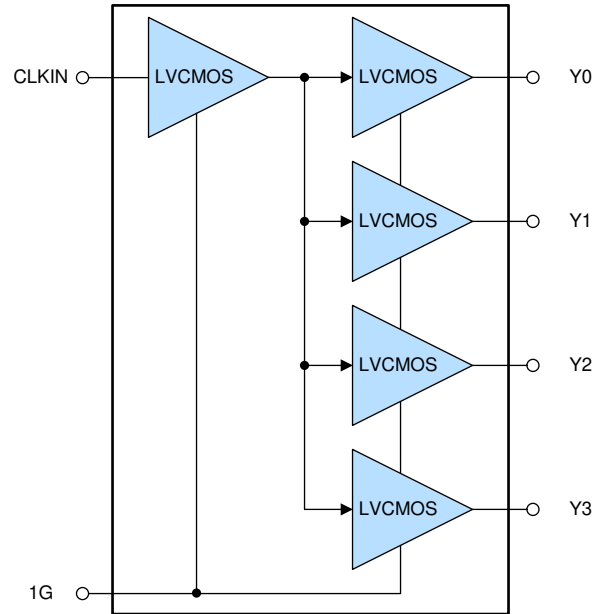

9.3 Feature Description

The outputs of the LMK1C110x can be disabled by driving the synchronous output enable pin (1G) low. Unused output can be left floating to reduce overall system component cost. Supply and ground pins must be connected to V_{DD} and GND, respectively.

9.3.1 Fail-Safe Inputs

The LMK1C110x family of devices is designed to support fail-safe input operation. This feature allows the user to drive the device inputs before VDD is applied without damaging the device. Refer to [Absolute Maximum Ratings](#) for more information on the maximum input supported by the device. The device also incorporates an input hysteresis that prevents random oscillation in absence of an input signal, allowing the input pins to be left open.

9.4 Device Functional Modes

The LMK1C110x operates from 1.8-V, 2.5-V, or 3.3-V supplies. 表 9-1 shows the output logics of the LMK1C110x.

表 9-1. Output Logic Table

INPUTS		OUTPUTS
CLKIN	1G	Yn
X	L	L
L	H	L
H	H	H

10 Application and Implementation

Note

以下のアプリケーション情報は、TI の製品仕様に含まれるものではなく、TI ではその正確性または完全性を保証いたしません。個々の目的に対する製品の適合性については、お客様の責任で判断していただくこととなります。お客様は自身の設計実装を検証しテストすることで、システムの機能を確認する必要があります。

10.1 Application Information

The LMK1C110x family is a low additive jitter LVCMOS buffer solution that can operate up to 250-MHz at $V_{DD} = 3.3\text{ V}$ and 200 MHz at $V_{DD} = 2.5\text{ V}$ to 1.8 V. Low output skew as well as the ability for synchronous output enable is featured to simultaneously enable or disable buffered clock outputs as necessary in the application.

10.2 Typical Application

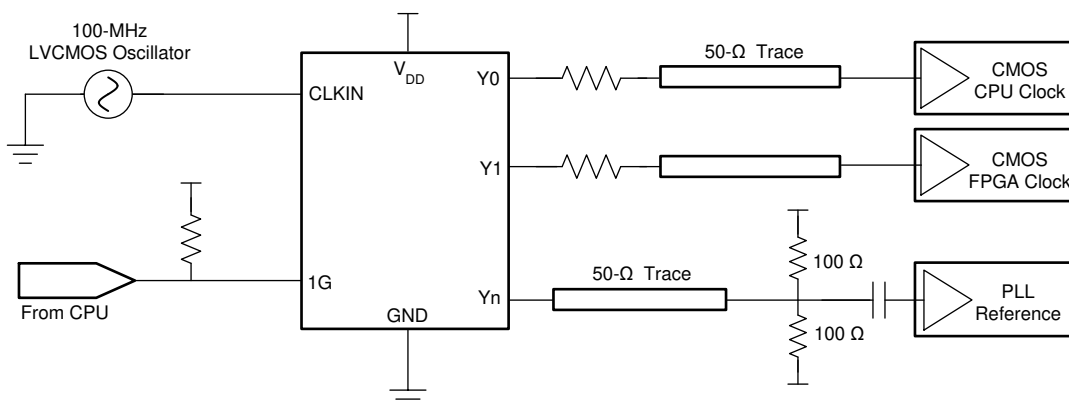

☒ 10-1. System Configuration Example

10.2.1 Design Requirements

The LMK1C110x shown in ☒ 10-1 is configured to fan out a 100-MHz signal from a local LVCMOS oscillator. The CPU is configured to control the output state through 1G.

The configuration example is driving three LVCMOS receivers in a backplane application with the following properties:

- The CPU clock can accept a full swing DC-coupled LVCMOS signal. A series resistor is placed near the LMK1C110x to closely match the characteristic impedance of the trace to minimize reflections.
- The FPGA clock is similarly DC-coupled with an appropriate series resistor placed near the LMK1C110x.
- The PLL in this example can accept a lower amplitude signal, so a Thevenin's equivalent termination is used. The PLL receiver features internal biasing, so AC coupling can be used when common-mode voltage is mismatched.

10.2.2 Detailed Design Procedure

Unused outputs can be left floating. See the [Power Supply Recommendations](#) section for recommended filtering techniques.

10.2.3 Application Curves

The low additive jitter of the LMK1C110x is shown in ☒ 10-2.

☒ 10-3 shows the low-noise 156.25-MHz reference source with 25.6-fs RMS jitter driving the LMK1C110x, resulting in 26.7-fs RMS jitter when integrated from 12 kHz to 20 MHz at 3.3-V supply. The resultant additive jitter measured is a low 7.6-fs RMS for this configuration.

☒ 10-4 shows the low-noise 156.25-MHz reference source with 25.6-fs RMS jitter driving the LMK1C110x, resulting in 27.5-fs RMS jitter when integrated from 12 kHz to 20 MHz at 2.5-V supply. The resultant additive jitter measured is a low 10-fs RMS for this configuration.

☒ 10-5 shows the low-noise 156.25-MHz reference source with 25.6-fs RMS jitter driving the LMK1C110x, resulting in 32-fs RMS jitter when integrated from 12 kHz to 20 MHz at 1.8-V supply. The resultant additive jitter measured is a low 19.2-fs RMS for this configuration.

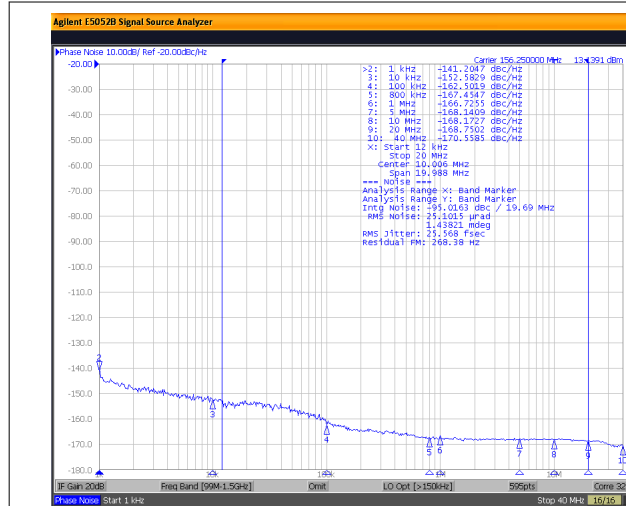

☒ 10-2. LMK1C110x Reference Phase Noise 25.6-fs (12 kHz to 20 MHz)

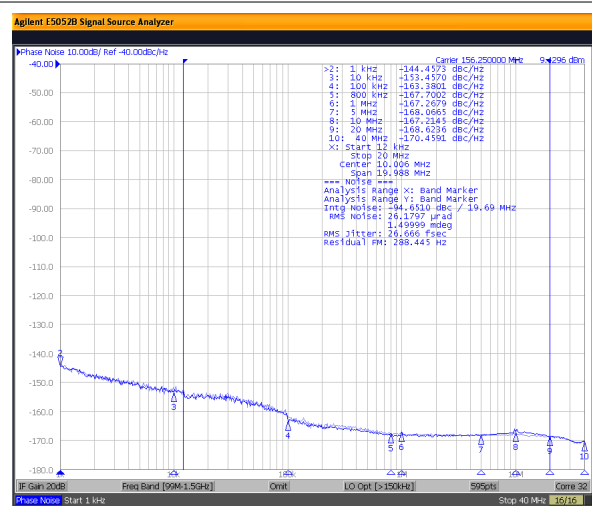

☒ 10-3. LMK1C110x 3.3-V Output Phase Noise 26.7-fs (12 kHz to 20 MHz)

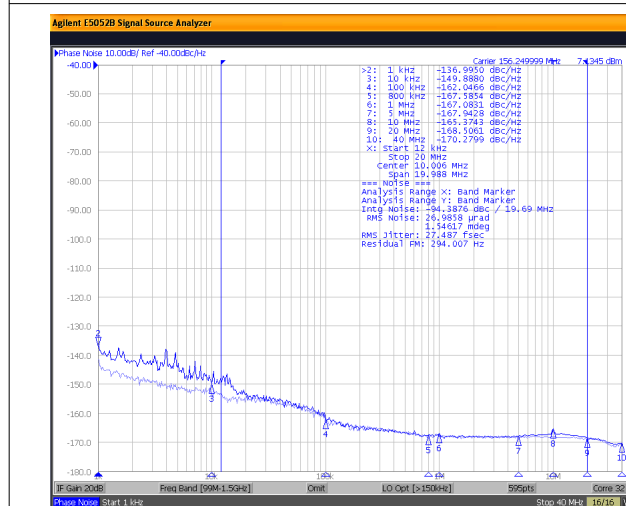

☒ 10-4. LMK1C110x 2.5-V Output Phase Noise 27.5-fs (12 kHz to 20 MHz)

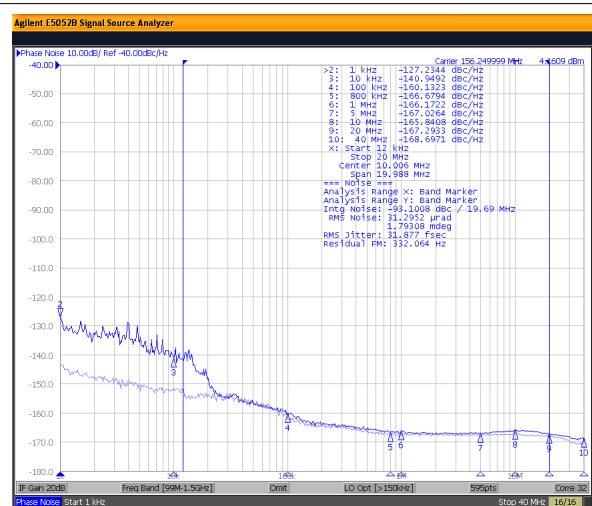

☒ 10-5. LMK1C110x 1.8-V Output Phase Noise 32-fs (12 kHz to 20 MHz)

11 Power Supply Recommendations

High-performance clock buffers can be sensitive to noise on the power supply, which may dramatically increase the additive jitter of the buffer. Thus, it is essential to manage any excessive noise from the system power supply, especially for applications where the jitter and phase noise performance is critical.

Filter capacitors are used to eliminate the low-frequency noise from the power supply, where the bypass capacitors provide the very low impedance path for high-frequency noise and guard the power supply system against induced fluctuations. These bypass capacitors also provide instantaneous current surges as required by the device and should have low equivalent series resistance (ESR). To properly bypass the supply, the decoupling capacitors must be placed very close to the power-supply terminals, be connected directly to the ground plane, and laid out with short loops to minimize inductance. TI recommends adding as many high-frequency (for example, 0.1 μF) bypass capacitors, as there are supply terminals in the package. TI recommends, but does not require, inserting a ferrite bead between the board power supply and the chip power supply that isolates the high-frequency switching noises generated by the clock buffer; these beads prevent the switching noise from leaking into the board supply. It is imperative to choose an appropriate ferrite bead with very low DC resistance to provide adequate isolation between the board supply and the chip supply, as well as to maintain a voltage at the supply terminals that is greater than the minimum voltage required for proper operation.

☒ 11-1 shows this recommended power supply decoupling method.

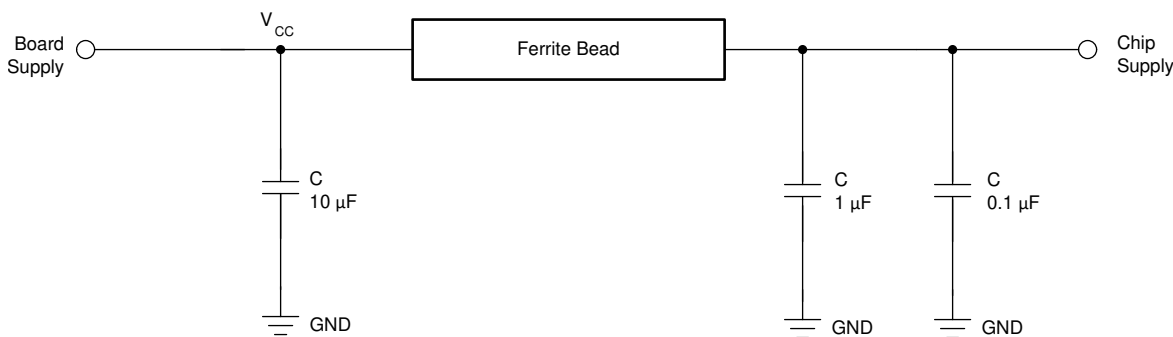

☒ 11-1. Power Supply Decoupling

12 Layout

12.1 Layout Guidelines

☒ 12-1 shows a conceptual layout detailing recommended placement of power supply bypass capacitors. For component side mounting, use 0402 body size capacitors to facilitate signal routing. Keep the connections between the bypass capacitors and the power supply on the device as short as possible. Ground the other side of the capacitor using a low-impedance connection to the ground plane.

☒ 12-2 provides a visual representation of the WSON device; it can be seen from the figure that similar to a DFN package, WSON doesn't have any leads.

12.2 Layout Example

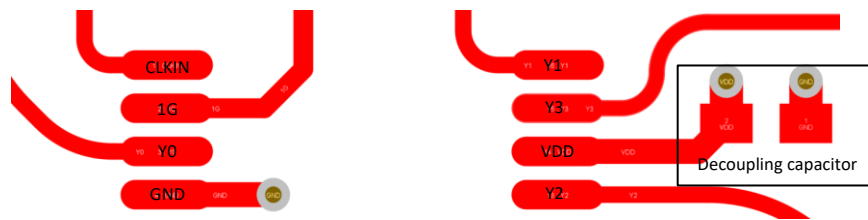

☒ 12-1. PCB Conceptual Layout

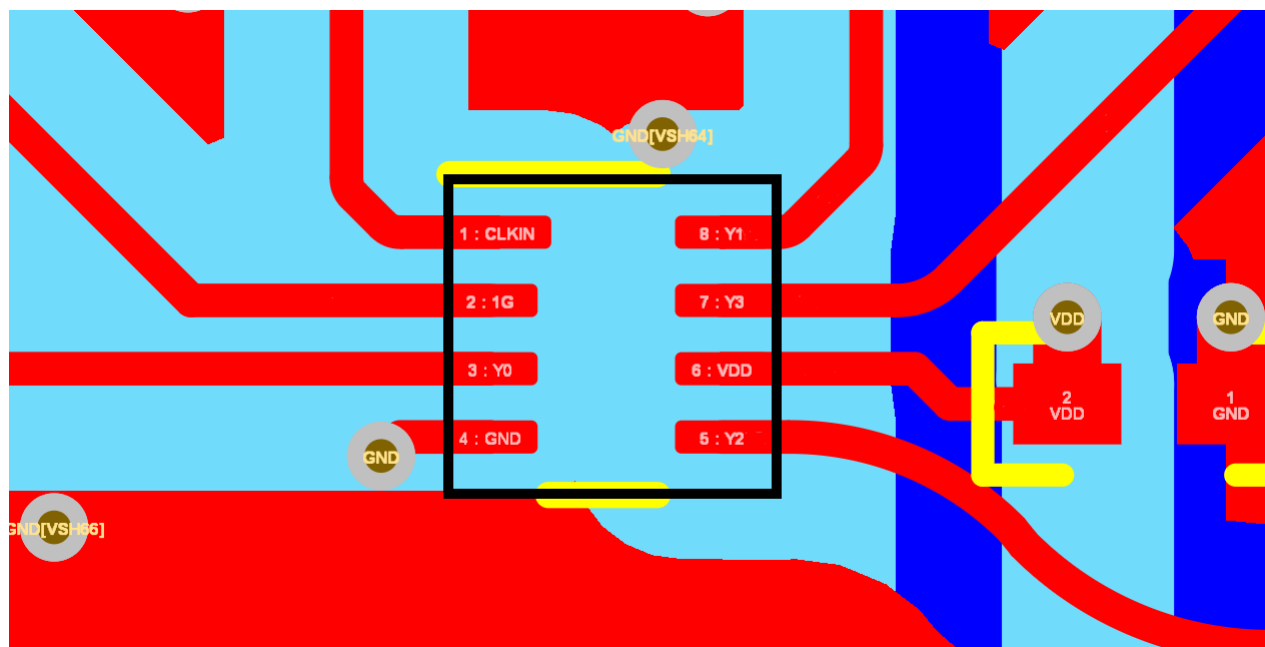

☒ 12-2. Layout illustration for 8-pin WSON device

13 Device and Documentation Support

13.1 Receiving Notification of Documentation Updates

To receive notification of documentation updates, navigate to the device product folder on [ti.com](https://www.ti.com). Click on *Subscribe to updates* to register and receive a weekly digest of any product information that has changed. For change details, review the revision history included in any revised document.

13.2 サポート・リソース

[TI E2E™ サポート・フォーラム](#)は、エンジニアが検証済みの回答と設計に関するヒントをエキスパートから迅速かつ直接得ることができる場所です。既存の回答を検索したり、独自の質問をしたりすることで、設計に必要な支援を迅速に得ることができます。

リンクされているコンテンツは、該当する貢献者により、現状のまま提供されるものです。これらは TI の仕様を構成するものではなく、必ずしも TI の見解を反映したものではありません。TI の[使用条件](#)を参照してください。

13.3 Trademarks

TI E2E™ is a trademark of Texas Instruments.

すべての商標は、それぞれの所有者に帰属します。

13.4 Electrostatic Discharge Caution



This integrated circuit can be damaged by ESD. Texas Instruments recommends that all integrated circuits be handled with appropriate precautions. Failure to observe proper handling and installation procedures can cause damage.

ESD damage can range from subtle performance degradation to complete device failure. Precision integrated circuits may be more susceptible to damage because very small parametric changes could cause the device not to meet its published specifications.

13.5 Glossary

[TI Glossary](#) This glossary lists and explains terms, acronyms, and definitions.

14 Mechanical, Packaging, and Orderable Information

The following pages include mechanical, packaging, and orderable information. This information is the most current data available for the designated devices. This data is subject to change without notice and revision of this document. For browser-based versions of this data sheet, refer to the left-hand navigation.

PACKAGING INFORMATION

Orderable part number	Status (1)	Material type (2)	Package Pins	Package qty Carrier	RoHS (3)	Lead finish/ Ball material (4)	MSL rating/ Peak reflow (5)	Op temp (°C)	Part marking (6)
LMK1C1102DQFR	Active	Production	WSON (DQF) 8	3000 LARGE T&R	Yes	NIPDAUAG	Level-1-260C-UNLIM	-40 to 125	L1C2
LMK1C1102DQFR.A	Active	Production	WSON (DQF) 8	3000 LARGE T&R	Yes	NIPDAUAG	Level-1-260C-UNLIM	-40 to 125	L1C2
LMK1C1102DQFT	Active	Production	WSON (DQF) 8	250 SMALL T&R	Yes	NIPDAUAG	Level-1-260C-UNLIM	-40 to 125	L1C2
LMK1C1102DQFT.A	Active	Production	WSON (DQF) 8	250 SMALL T&R	Yes	NIPDAUAG	Level-1-260C-UNLIM	-40 to 125	L1C2
LMK1C1102PWR	Active	Production	TSSOP (PW) 8	2000 LARGE T&R	Yes	NIPDAU	Level-1-260C-UNLIM	-40 to 125	LMK1C2
LMK1C1102PWR.A	Active	Production	TSSOP (PW) 8	2000 LARGE T&R	Yes	NIPDAU	Level-1-260C-UNLIM	-40 to 125	LMK1C2
LMK1C1102PWRG4	Active	Production	TSSOP (PW) 8	2000 LARGE T&R	Yes	NIPDAU	Level-1-260C-UNLIM	-40 to 125	LMK1C2
LMK1C1102PWRG4.A	Active	Production	TSSOP (PW) 8	2000 LARGE T&R	Yes	NIPDAU	Level-1-260C-UNLIM	-40 to 125	LMK1C2
LMK1C1103PWR	Active	Production	TSSOP (PW) 8	2000 LARGE T&R	Yes	NIPDAU	Level-1-260C-UNLIM	-40 to 125	LMK1C3
LMK1C1103PWR.A	Active	Production	TSSOP (PW) 8	2000 LARGE T&R	Yes	NIPDAU	Level-1-260C-UNLIM	-40 to 125	LMK1C3
LMK1C1103PWRG4	Active	Production	TSSOP (PW) 8	2000 LARGE T&R	Yes	NIPDAU	Level-1-260C-UNLIM	-40 to 125	LMK1C3
LMK1C1103PWRG4.A	Active	Production	TSSOP (PW) 8	2000 LARGE T&R	Yes	NIPDAU	Level-1-260C-UNLIM	-40 to 125	LMK1C3
LMK1C1104DQFR	Active	Production	WSON (DQF) 8	3000 LARGE T&R	Yes	NIPDAUAG	Level-1-260C-UNLIM	-40 to 125	L1C4
LMK1C1104DQFR.A	Active	Production	WSON (DQF) 8	3000 LARGE T&R	Yes	NIPDAUAG	Level-1-260C-UNLIM	-40 to 125	L1C4
LMK1C1104DQFT	Active	Production	WSON (DQF) 8	250 SMALL T&R	Yes	NIPDAUAG	Level-1-260C-UNLIM	-40 to 125	L1C4
LMK1C1104DQFT.A	Active	Production	WSON (DQF) 8	250 SMALL T&R	Yes	NIPDAUAG	Level-1-260C-UNLIM	-40 to 125	L1C4
LMK1C1104PWR	Active	Production	TSSOP (PW) 8	2000 LARGE T&R	Yes	NIPDAU	Level-1-260C-UNLIM	-40 to 125	LMK1C4
LMK1C1104PWR.A	Active	Production	TSSOP (PW) 8	2000 LARGE T&R	Yes	NIPDAU	Level-1-260C-UNLIM	-40 to 125	LMK1C4
LMK1C1104PWRG4	Active	Production	TSSOP (PW) 8	2000 LARGE T&R	Yes	NIPDAU	Level-1-260C-UNLIM	-40 to 125	LMK1C4
LMK1C1104PWRG4.A	Active	Production	TSSOP (PW) 8	2000 LARGE T&R	Yes	NIPDAU	Level-1-260C-UNLIM	-40 to 125	LMK1C4

(1) **Status:** For more details on status, see our [product life cycle](#).

(2) **Material type:** When designated, preproduction parts are prototypes/experimental devices, and are not yet approved or released for full production. Testing and final process, including without limitation quality assurance, reliability performance testing, and/or process qualification, may not yet be complete, and this item is subject to further changes or possible discontinuation. If available for ordering, purchases will be subject to an additional waiver at checkout, and are intended for early internal evaluation purposes only. These items are sold without warranties of any kind.

(3) **RoHS values:** Yes, No, RoHS Exempt. See the [TI RoHS Statement](#) for additional information and value definition.

(4) **Lead finish/Ball material:** Parts may have multiple material finish options. Finish options are separated by a vertical ruled line. Lead finish/Ball material values may wrap to two lines if the finish value exceeds the maximum column width.

(5) **MSL rating/Peak reflow:** The moisture sensitivity level ratings and peak solder (reflow) temperatures. In the event that a part has multiple moisture sensitivity ratings, only the lowest level per JEDEC standards is shown. Refer to the shipping label for the actual reflow temperature that will be used to mount the part to the printed circuit board.

(6) **Part marking:** There may be an additional marking, which relates to the logo, the lot trace code information, or the environmental category of the part.

Multiple part markings will be inside parentheses. Only one part marking contained in parentheses and separated by a "~" will appear on a part. If a line is indented then it is a continuation of the previous line and the two combined represent the entire part marking for that device.

Important Information and Disclaimer: The information provided on this page represents TI's knowledge and belief as of the date that it is provided. TI bases its knowledge and belief on information provided by third parties, and makes no representation or warranty as to the accuracy of such information. Efforts are underway to better integrate information from third parties. TI has taken and continues to take reasonable steps to provide representative and accurate information but may not have conducted destructive testing or chemical analysis on incoming materials and chemicals. TI and TI suppliers consider certain information to be proprietary, and thus CAS numbers and other limited information may not be available for release.

In no event shall TI's liability arising out of such information exceed the total purchase price of the TI part(s) at issue in this document sold by TI to Customer on an annual basis.

TAPE AND REEL INFORMATION

QUADRANT ASSIGNMENTS FOR PIN 1 ORIENTATION IN TAPE

*All dimensions are nominal

Device	Package Type	Package Drawing	Pins	SPQ	Reel Diameter (mm)	Reel Width W1 (mm)	A0 (mm)	B0 (mm)	K0 (mm)	P1 (mm)	W (mm)	Pin1 Quadrant
LMK1C1102DQFR	WSOP	DQF	8	3000	178.0	8.4	2.25	2.25	1.0	4.0	8.0	Q2
LMK1C1102DQFT	WSOP	DQF	8	250	178.0	8.4	2.25	2.25	1.0	4.0	8.0	Q2
LMK1C1102PWR	TSSOP	PW	8	2000	330.0	12.4	7.0	3.6	1.6	8.0	12.0	Q1
LMK1C1102PWRG4	TSSOP	PW	8	2000	330.0	12.4	7.0	3.6	1.6	8.0	12.0	Q1
LMK1C1103PWR	TSSOP	PW	8	2000	330.0	12.4	7.0	3.6	1.6	8.0	12.0	Q1
LMK1C1103PWRG4	TSSOP	PW	8	2000	330.0	12.4	7.0	3.6	1.6	8.0	12.0	Q1
LMK1C1104DQFR	WSOP	DQF	8	3000	178.0	8.4	2.25	2.25	1.0	4.0	8.0	Q2
LMK1C1104DQFT	WSOP	DQF	8	250	178.0	8.4	2.25	2.25	1.0	4.0	8.0	Q2
LMK1C1104PWR	TSSOP	PW	8	2000	330.0	12.4	7.0	3.6	1.6	8.0	12.0	Q1
LMK1C1104PWRG4	TSSOP	PW	8	2000	330.0	12.4	7.0	3.6	1.6	8.0	12.0	Q1

TAPE AND REEL BOX DIMENSIONS

*All dimensions are nominal

Device	Package Type	Package Drawing	Pins	SPQ	Length (mm)	Width (mm)	Height (mm)
LMK1C1102DQFR	WSON	DQF	8	3000	205.0	200.0	33.0
LMK1C1102DQFT	WSON	DQF	8	250	205.0	200.0	33.0
LMK1C1102PWR	TSSOP	PW	8	2000	353.0	353.0	32.0
LMK1C1102PWRG4	TSSOP	PW	8	2000	353.0	353.0	32.0
LMK1C1103PWR	TSSOP	PW	8	2000	353.0	353.0	32.0
LMK1C1103PWRG4	TSSOP	PW	8	2000	353.0	353.0	32.0
LMK1C1104DQFR	WSON	DQF	8	3000	205.0	200.0	33.0
LMK1C1104DQFT	WSON	DQF	8	250	205.0	200.0	33.0
LMK1C1104PWR	TSSOP	PW	8	2000	353.0	353.0	32.0
LMK1C1104PWRG4	TSSOP	PW	8	2000	353.0	353.0	32.0

GENERIC PACKAGE VIEW

DQF 8

WSON - 0.8 mm max height

2 x 2, 0.5 mm pitch

PLASTIC SMALL OUTLINE - NO LEAD

This image is a representation of the package family, actual package may vary.
Refer to the product data sheet for package details.

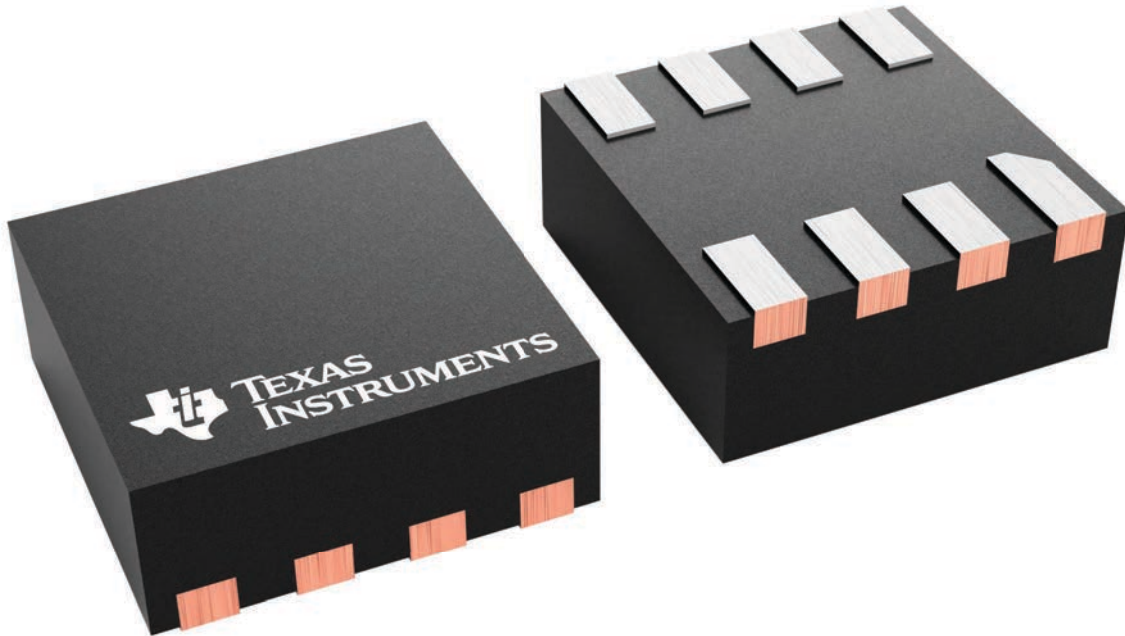

4232898/A

EXAMPLE BOARD LAYOUT

DQF0008A

WSON - 0.8 mm max height

PLASTIC SMALL OUTLINE - NO LEAD

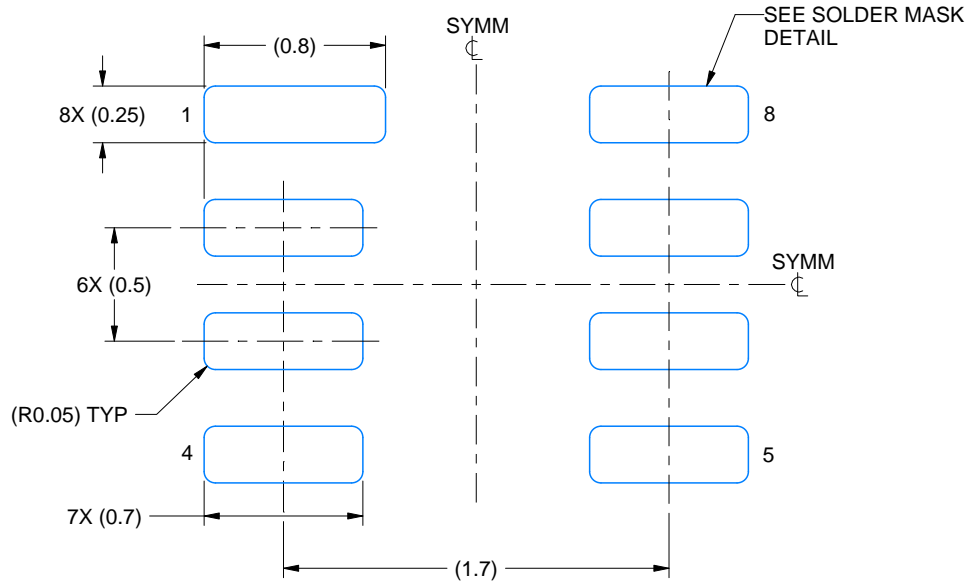

LAND PATTERN EXAMPLE
EXPOSED METAL SHOWN
SCALE: 30X

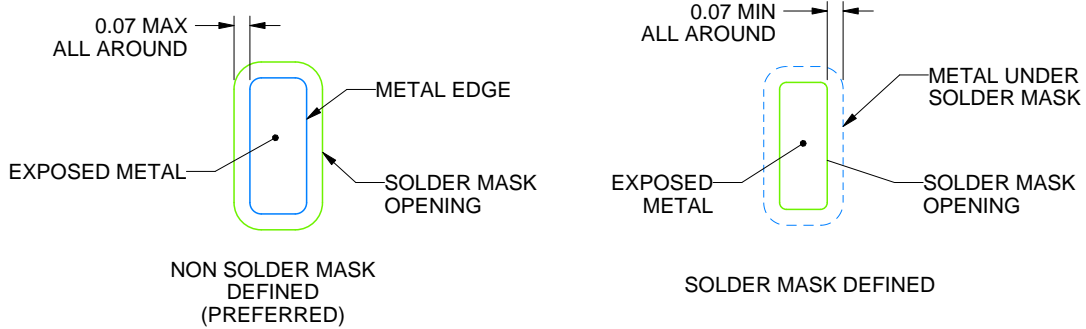

SOLDER MASK DETAILS

4220563/A 03/2021

NOTES: (continued)

- This package is designed to be soldered to a thermal pad on the board. For more information, see Texas Instruments literature number SLUA271 (www.ti.com/lit/slua271).

EXAMPLE STENCIL DESIGN

DQF0008A

WSON - 0.8 mm max height

PLASTIC SMALL OUTLINE - NO LEAD

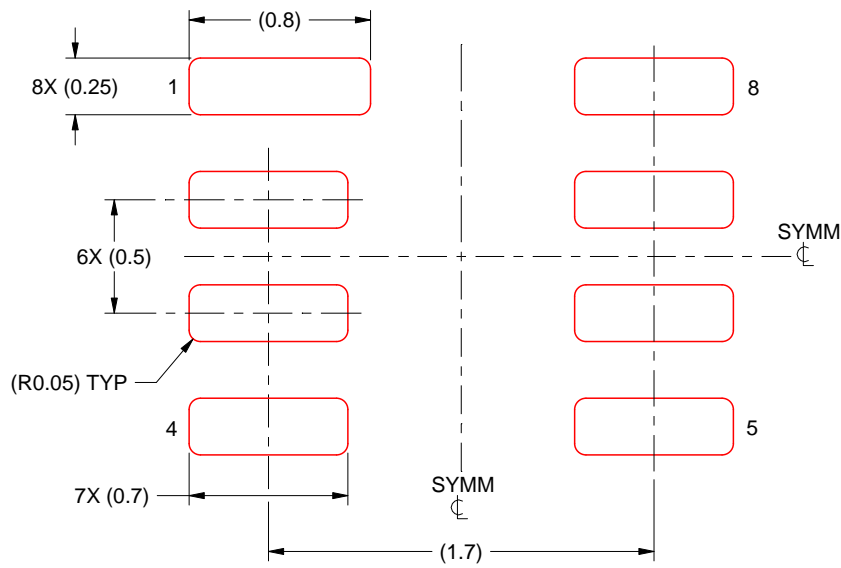

SOLDER PASTE EXAMPLE
BASED ON 0.125 MM THICK STENCIL
SCALE: 30X

4220563/A 03/2021

NOTES: (continued)

4. Laser cutting apertures with trapezoidal walls and rounded corners may offer better paste release. IPC-7525 may have alternate design recommendations.

PW0008A



PACKAGE OUTLINE
TSSOP - 1.2 mm max height

SMALL OUTLINE PACKAGE

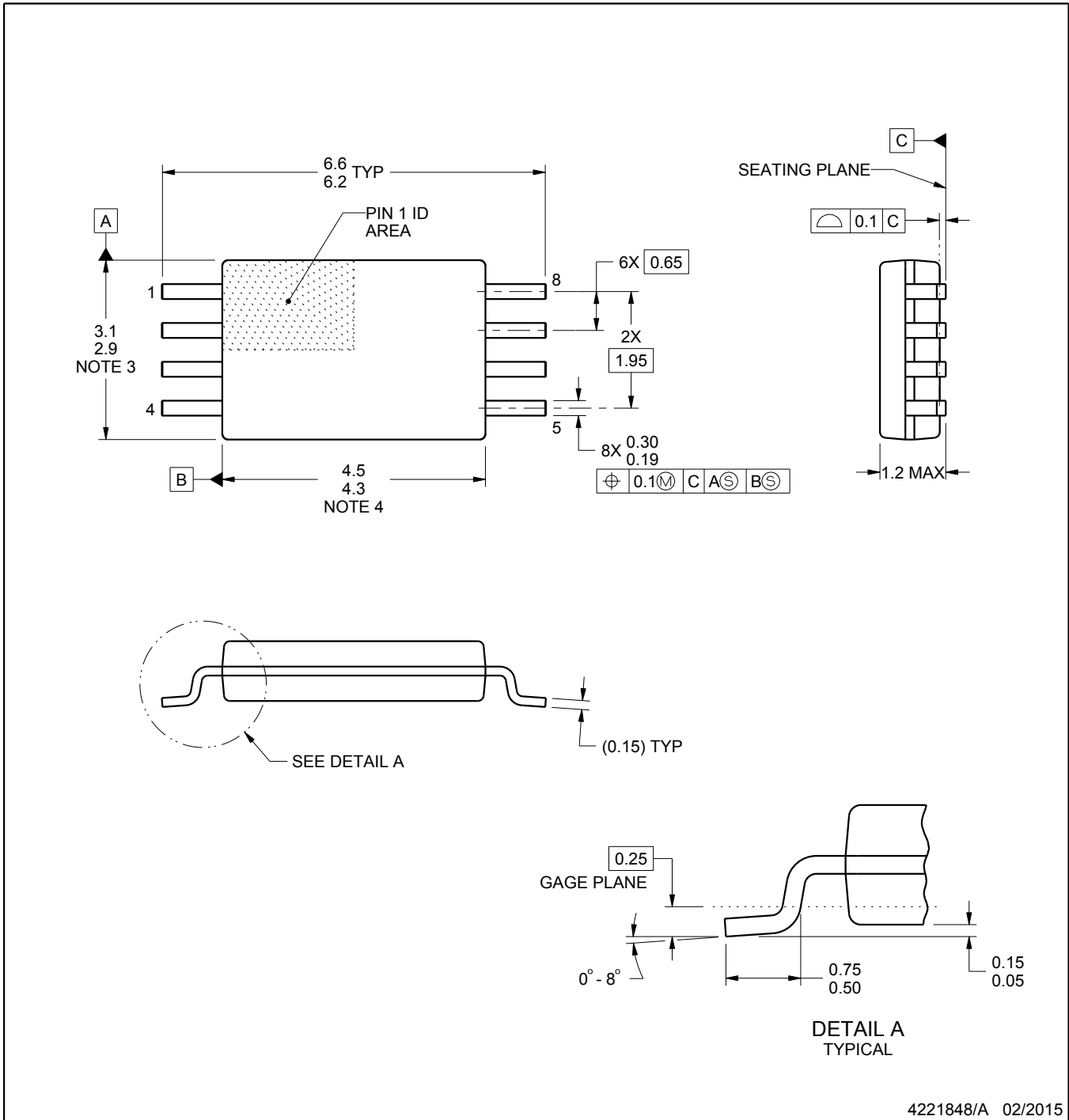

4221848/A 02/2015

NOTES:

1. All linear dimensions are in millimeters. Any dimensions in parenthesis are for reference only. Dimensioning and tolerancing per ASME Y14.5M.
2. This drawing is subject to change without notice.
3. This dimension does not include mold flash, protrusions, or gate burrs. Mold flash, protrusions, or gate burrs shall not exceed 0.15 mm per side.
4. This dimension does not include interlead flash. Interlead flash shall not exceed 0.25 mm per side.
5. Reference JEDEC registration MO-153, variation AA.

EXAMPLE BOARD LAYOUT

PW0008A

TSSOP - 1.2 mm max height

SMALL OUTLINE PACKAGE

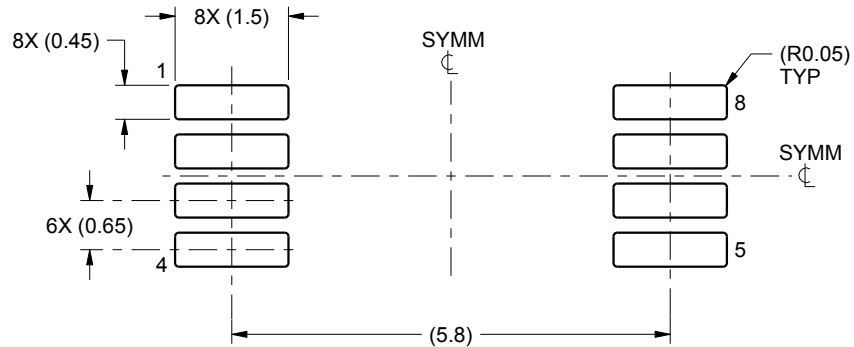

LAND PATTERN EXAMPLE
SCALE:10X

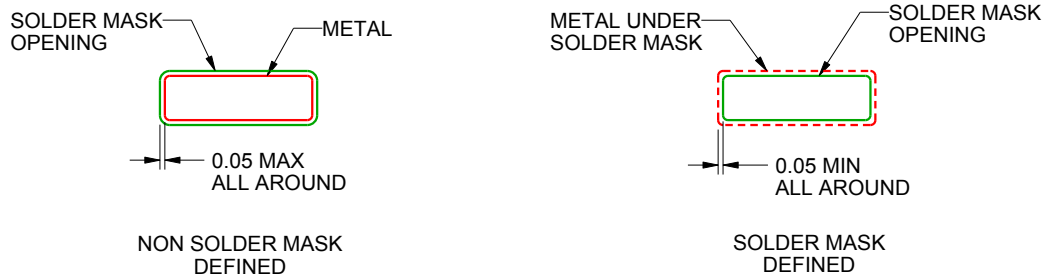

SOLDER MASK DETAILS
NOT TO SCALE

4221848/A 02/2015

NOTES: (continued)

- 6. Publication IPC-7351 may have alternate designs.
- 7. Solder mask tolerances between and around signal pads can vary based on board fabrication site.

EXAMPLE STENCIL DESIGN

PW0008A

TSSOP - 1.2 mm max height

SMALL OUTLINE PACKAGE

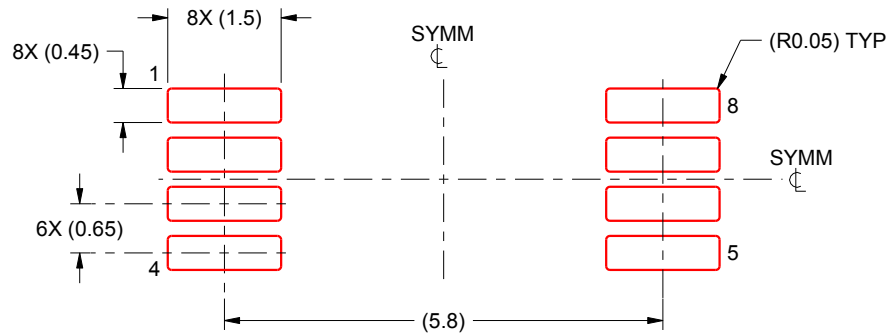

SOLDER PASTE EXAMPLE
BASED ON 0.125 mm THICK STENCIL
SCALE:10X

4221848/A 02/2015

NOTES: (continued)

8. Laser cutting apertures with trapezoidal walls and rounded corners may offer better paste release. IPC-7525 may have alternate design recommendations.
9. Board assembly site may have different recommendations for stencil design.

重要なお知らせと免責事項

TI は、技術データと信頼性データ (データシートを含みます)、設計リソース (リファレンス デザインを含みます)、アプリケーションや設計に関する各種アドバイス、Web ツール、安全性情報、その他のリソースを、欠陥が存在する可能性のある「現状のまま」提供しており、商品性および特定目的に対する適合性の黙示保証、第三者の知的財産権の非侵害保証を含むいかなる保証も、明示的または黙示的にかかわらず拒否します。

これらのリソースは、TI 製品を使用する設計の経験を積んだ開発者への提供を意図したものです。(1) お客様のアプリケーションに適した TI 製品の選定、(2) お客様のアプリケーションの設計、検証、試験、(3) お客様のアプリケーションに該当する各種規格や、その他のあらゆる安全性、セキュリティ、規制、または他の要件への確実な適合に関する責任を、お客様のみが単独で負うものとし、

上記の各種リソースは、予告なく変更される可能性があります。これらのリソースは、リソースで説明されている TI 製品を使用するアプリケーションの開発の目的でのみ、TI はその使用をお客様に許諾します。これらのリソースに関して、他の目的で複製することや掲載することは禁止されています。TI や第三者の知的財産権のライセンスが付与されている訳ではありません。お客様は、これらのリソースを自身で使用した結果発生するあらゆる申し立て、損害、費用、損失、責任について、TI およびその代理人を完全に補償するものとし、TI は一切の責任を拒否します。

TI の製品は、[TI の販売条件](#)、[TI の総合的な品質ガイドライン](#)、[ti.com](#) または TI 製品などに関連して提供される他の適用条件に従い提供されます。TI がこれらのリソースを提供することは、適用される TI の保証または他の保証の放棄の拡大や変更を意味するものではありません。TI がカスタム、またはカスタマー仕様として明示的に指定していない限り、TI の製品は標準的なカタログに掲載される汎用機器です。

お客様がいかなる追加条項または代替条項を提案する場合も、TI はそれらに異議を唱え、拒否します。

Copyright © 2026, Texas Instruments Incorporated

最終更新日 : 2025 年 10 月