

TRSF3221E ±15kV IEC ESD 保護機能搭載、小型パッケージの 3V~5.5V シングルチャンネル RS-232 1Mbit ラインドライバ/レシーバ

1 特長

- RS-232 ピンの ESD 保護
 - ±15kV 人体モデル (HBM)
 - ±8kV IEC 61000-4-2 接触放電
 - ±15kV IEC 61000-4-2 エアギャップ放電
- 3V~5.5V の V_{CC} 電源で動作
- 最大 1Mbit/s で動作
 - 低速のピン互換デバイス (250kbit/s) – TRSF3221E
- ニア チップスケール パッケージ、16 ピン VQFN (RGT、TSSOP パッケージより 82% 小型) で供給
- 小さいスタンバイ電流: 1µA (標準値)
- 外付けコンデンサ: 4 × 0.1µF
- 3.3V 電源で 5V ロジック入力を許容
- 自動パワーダウン機能により、ドライバを自動的にディセーブすることで電力を節約

2 アプリケーション

- 産業用 PC
- 有線ネットワーク
- データ・センターおよびエンタープライズ・コンピューティング
- バッテリー駆動システム
- PDA
- ノートブック PC
- ノート PC
- パームトップ PC
- ハンドヘルド機器

3 概要

TRSF3221E デバイスは 1 つのラインドライバ、1 つのラインレシーバ、1 つのデュアル チャージポンプ回路で構成されており、±15kV のピン間 (シリアルポート接続ピン、GND を含む) IEC ESD 保護機能を備えています。TRSF3221E は、非同期通信コントローラとシリアルポートコネクタの間の電氣的インターフェイスとして機能します。チャージポンプと 4 つの小さな外付けコンデンサにより、3V~5.5V の単一電源で動作できます。TRSF3221E は最大 1Mbit/s のデータ信号速度、24V/µs~150V/µs のドライバ出力スlewレイトで動作します。

シリアルポートが使われていない際のパワーマネージメントを柔軟に制御できます。FORCEON が LOW かつ FORCEOFF が HIGH の場合、自動パワーダウン機能が動作します。この動作モード中、TRSF3221E がレシーバ入力で有効な RS-232 信号を検出しない場合、ドライバ出力はディセーブになります。FORCEOFF を Low に設定しかつイネーブル (EN) 入力を High に設定すると、ドライバとレシーバはどちらもシャットダウンされ、消費電流は 1µA に減少します。シリアルポートを切り離れた場合、またはペリフェラルドライバをオフにした場合、自動パワーダウン状態になります。FORCEON と FORCEOFF を HIGH にすると、自動パワーダウンが無効にできます。自動パワーダウンが有効な場合、レシーバの入力に有効な信号が印加されると、デバイスは自動的にアクティブになります。INVALID 出力は、レシーバの入力に RS-232 信号が存在するかどうかをユーザーに通知します。INVALID は、レシーバの入力電圧が 2.7V を上回っている、または -2.7V を下回っている、あるいは -0.3V と 0.3V の間にあった期間が 30µs 未満である場合、HIGH (有効データ) になります。INVALID は、レシーバの入力電圧が 30µs を超えて -0.3V と 0.3V の間にある場合、Low (無効データ) になります。レシーバの入力レベルについては、図 6-5 を参照してください。

パッケージ情報

部品番号	パッケージ (1)	パッケージサイズ (2)
TRSF3221E	DB (SSOP)	6.2 mm × 5.3mm
	PW (TSSOP)	5 mm × 4.4mm
	RGT (VQFN)	3 mm × 3mm
	SOT-23-THN (DYY) (16)	4.2mm × 2mm

- 詳細については、セクション 11 を参照してください。
- パッケージサイズ (長さ × 幅) は公称値であり、該当する場合はピンも含まれます。

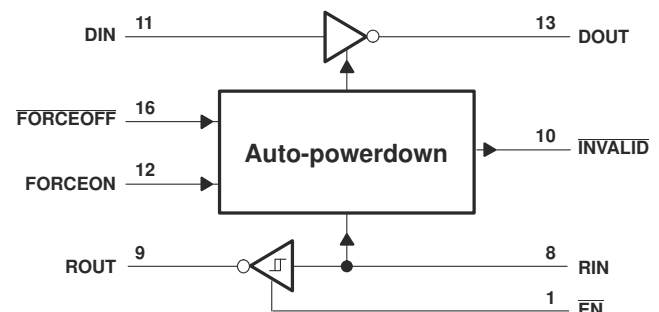

論理図 (正論理)

Table of Contents

1 特長	1	7 Detailed Description	13
2 アプリケーション	1	7.1 Overview.....	13
3 概要	1	7.2 Functional Block Diagram.....	13
4 Pin Configuration and Functions	3	7.3 Feature Description.....	13
5 Specifications	5	7.4 Device Functional Modes.....	14
5.1 Absolute Maximum Ratings.....	5	8 Application and Implementation	15
5.2 ESD Ratings.....	5	8.1 Application Information.....	15
5.3 ESD Ratings, IEC Specifications.....	5	8.2 Power Supply Recommendations.....	16
5.4 Recommended Operating Conditions.....	6	8.3 Layout.....	17
5.5 Thermal Resistance Characteristics.....	6	9 Device and Documentation Support	18
5.6 Electrical Characteristics.....	6	9.1 ドキュメントの更新通知を受け取る方法.....	18
5.7 Electrical Characteristics, Driver.....	7	9.2 サポート・リソース.....	18
5.8 Switching Characteristics, Driver.....	7	9.3 商標.....	18
5.9 Electrical Characteristics, Receiver.....	8	9.4 静電気放電に関する注意事項.....	18
5.10 Switching Characteristics, Receiver.....	8	9.5 用語集.....	18
5.11 Electrical Characteristics, Auto-Powerdown.....	9	10 Revision History	18
5.12 Switching Characteristics, Auto-Powerdown.....	9	11 Mechanical, Packaging, and Orderable Information	19
5.13 Typical Characteristics.....	9		
6 Parameter Measurement Information	10		

4 Pin Configuration and Functions



表 4-1. Pin Functions

NAME	PIN		TYPE ⁽¹⁾	DESCRIPTION
	DB or PW	RGT		
EN	1	14	--	Low input enables receiver ROUT output. High input sets ROUT to high impedance.
C1+	2	16	-	Positive lead of C1 capacitor
V+	3	15	O	Positive charge pump output for storage capacitor only
C1-	4	1	-	Negative lead of C1 capacitor
C2+	5	2	-	Positive lead of C2 capacitor
C2-	6	3	-	Negative lead of C2 capacitor
V-	7	4	O	Negative charge pump output for storage capacitor only
RIN	8	5	I	RS232 line data input (from remote RS232 system)
ROUT	9	6	O	Logic data output (to UART)
INVALID	10	7		Invalid output pin. Output low when RIN input is unpowered.
DIN	11	8	I	Logic data input (from UART)
FORCEON	12	9		Automatic power-down control input
DOUT	13	10	O	RS232 line data output (to remote RS232 system)
GRD	14	11	-	Ground
V _{CC}	15	12	-	Supply Voltage, Connect to external 3V to 5.5V power supply
FORCEOFF	16	13		Automatic power-down control input
Thermal Pad	-	Yes	-	Exposed thermal pad. Can be connected to GND or left floating.

(1) Signal Types: I = Input, O = Output, I/O = Input or Output.

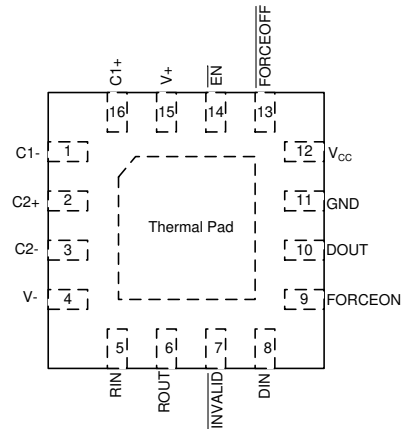
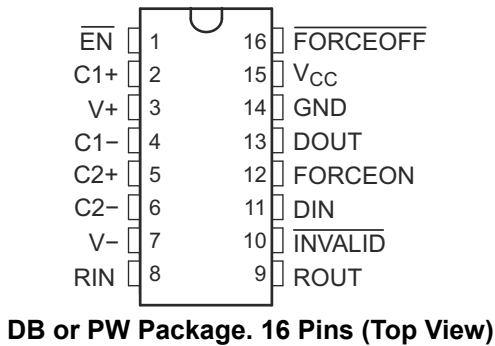
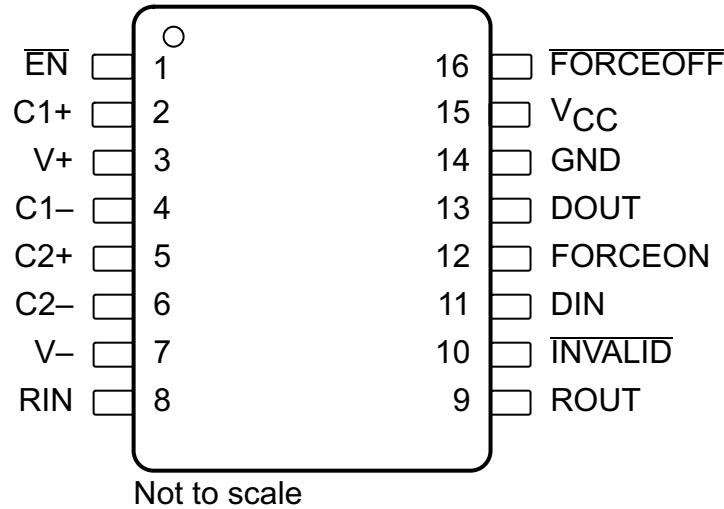

**図 4-1. DYY Package
16-Pin SOT-23-THN
(Top View)**

表 4-2. Pin Functions

PIN		TYPE	DESCRIPTION
NAME	NO.		
EN	1	I	Low input enables receiver ROUT output. High input sets ROUT to high impedance.
C1+	2	—	Positive terminals of the voltage-doubler charge pump capacitors
V+	3	O	5.5V supply generated by the charge pump
C1-	4	—	Negative terminals of the voltage-doubler charge pump capacitors
C2+	5	—	Positive terminals of the voltage-doubler charge pump capacitors
C2-	6	—	Negative terminals of the voltage-doubler charge pump capacitors
V-	7	O	-5.5V supply generated by the charge pump
RIN	8	I	RS-232 receiver input
ROUT	9	O	Receiver output
INVALID	10	O	Invalid output pin. Output low when RIN input is unpowered.
DIN	11	I	Driver input
FORCEON	12	I	Automatic power-down control input
DOUT	13	O	RS-232 driver output
GND	14	—	Ground
V _{CC}	15	—	3V to 5.5V supply voltage
FORCEOFF	16	I	Automatic power-down control input

5 Specifications

5.1 Absolute Maximum Ratings

over operating free-air temperature range (unless otherwise noted) See ⁽¹⁾

		MIN	MAX	UNIT	
V _{CC}	Supply voltage range ⁽²⁾	-0.3	6	V	
V+	Positive output supply voltage range ⁽²⁾	-0.3	7	V	
V-	Negative output supply voltage range ⁽²⁾	0.3	-7	V	
V+ - V-	Supply voltage difference ⁽²⁾		13	V	
V _I	Input voltage range	Driver (FORCEOFF, FORCEON, EN)	-0.3	6	V
		Receiver	-25	25	
V _O	Output voltage range	Driver	-13.2	13.2	V
		Receiver (INVALID)	-0.3	V _{CC} + 0.3	
T _J	Operating virtual junction temperature		150	°C	
T _{stg}	Storage temperature range	-65	150	°C	

- (1) Stresses beyond those listed under "absolute maximum ratings" may cause permanent damage to the device. These are stress ratings only, and functional operation of the device at these or any other conditions beyond those indicated under "recommended operating conditions" is not implied. Exposure to absolute-maximum-rated conditions for extended periods may affect device reliability.
- (2) All voltages are with respect to network GND.

5.2 ESD Ratings

		VALUE	UNIT	
V _(ESD)	Electrostatic discharge	Human-body model (HBM), per ANSI/ESDA/JEDEC JS-001 ⁽¹⁾	±3000	V
		Charged-device model (CDM), per JEDEC specification JESD22-C101 ⁽²⁾	±1500	

- (1) JEDEC document JEP155 states that 500-V HBM allows safe manufacturing with a standard ESD control process.
- (2) JEDEC document JEP157 states that 250-V CDM allows safe manufacturing with a standard ESD control process.

5.3 ESD Ratings, IEC Specifications

PIN NAME	TEST CONDITIONS	VALUE	UNIT
RIN, DOUT ⁽²⁾	HBM	±15,000	V
	IEC 61000-4-2 Contact Discharge ^{(1) (2)}	±8,000	
	IEC 61000-4-2 Air-Gap Discharge ^{(1) (2)}	±15,000	

- (1) For the RGT and PW package only, a minimum of 1µF capacitor is required between VCC and GND to meet the specified IEC-ESD level.
- (2) For optimized IEC ESD performance for DYY package, the recommendation is to have series resistor (≥ 50Ω), on all logic inputs directly connected to power or ground, to minimize the transient currents going into or out of the logic pins.

5.4 Recommended Operating Conditions

 See [Figure 8-1](#) and ⁽¹⁾

			MIN	NOM	MAX	UNIT
Supply voltage		$V_{CC} = 3.3\text{ V}$	3	3.3	3.6	V
		$V_{CC} = 5\text{ V}$	4.5	5	5.5	
V_{IH}	Driver and control high-level input voltage	DIN, FORCEOFF, FORCEON, EN	$V_{CC} = 3.3\text{ V}$	2		V
			$V_{CC} = 5\text{ V}$	2.4		
V_{IL}	Driver and control low-level input voltage	DIN, FORCEOFF, FORCEON, EN			0.8	V
V_I	Driver and control input voltage	DIN, FORCEOFF, FORCEON	0		5.5	V
V_I	Receiver input voltage		-25		25	V
T_A	Operating free-air temperature	TRSF3221EI	-40		85	°C
		TRSF3221EC	0		70	

⁽¹⁾ Test conditions are C1–C4 = 0.1 μF at $V_{CC} = 3.3\text{ V} \pm 0.3\text{ V}$; C1 = 0.047 μF , C2–C4 = 0.33 μF at $V_{CC} = 5\text{ V} \pm 0.5\text{ V}$.

5.5 Thermal Resistance Characteristics

THERMAL METRIC ⁽¹⁾		TRSF3221E				UNIT
		DB (SSOP)	PW (TSSOP)	RGT (VQFN)	DYY (SOT-23-THN)	
		16 Pins	16 Pins	16 Pins	16 Pins	
$R_{\theta JA}$	Junction-to-ambient thermal resistance	82	110.9	58.8	119.8	°C/W
$R_{\theta JC(top)}$	Junction-to-case (top) thermal resistance	45.7	41.7	55.8	56.5	°C/W
$R_{\theta JB}$	Junction-to-board thermal resistance	44.4	57.2	23.8	51.5	°C/W
Ψ_{JT}	Junction-to-top characterization parameter	11.0	4.2	1.7	2.6	°C/W
Ψ_{JB}	Junction-to-board characterization parameter	43.8	56.6	23.7	51.1	°C/W
$R_{\theta JC(bot)}$	Junction-to-case (bottom) thermal resistance	N/A	N/A	9	N/A	°C/W

⁽¹⁾ For more information about traditional and new thermal metrics, see the [Semiconductor and IC package thermal metrics](#) application report.

5.6 Electrical Characteristics

over recommended ranges of supply voltage and operating free-air temperature (unless otherwise noted)

 (see [Figure 8-1](#))

PARAMETER		TEST CONDITIONS ⁽¹⁾	MIN	TYP ⁽²⁾	MAX	UNIT	
I_I	Input leakage current	FORCEOFF, FORCEON, EN		± 0.01	± 1	μA	
I_{CC}	Supply current ($T_A = 25^\circ\text{C}$)	Auto-powerdown disabled	No load, FORCEOFF and FORCEON at V_{CC}		0.3	1	mA
		Powered off	No load, FORCEOFF at GND		1	10	
		Auto-powerdown enabled	No load, FORCEOFF at V_{CC} , FORCEON at GND, All RIN are open or grounded		1	10	μA

⁽¹⁾ Test conditions are C1–C4 = 0.1 μF at $V_{CC} = 3.3\text{ V} \pm 0.3\text{ V}$; C1 = 0.047 μF , C2–C4 = 0.33 μF at $V_{CC} = 5\text{ V} \pm 0.5\text{ V}$.

⁽²⁾ All typical values are at $V_{CC} = 3.3\text{ V}$ or $V_{CC} = 5\text{ V}$, and $T_A = 25^\circ\text{C}$.

5.7 Electrical Characteristics, Driver

over recommended ranges of supply voltage and operating free-air temperature (unless otherwise noted)
(see [8-1](#))

PARAMETER		TEST CONDITIONS ⁽¹⁾	MIN	TYP ⁽²⁾	MAX	UNIT
V _{OH}	High-level output voltage	DOOUT at R _L = 3 kΩ to GND, DIN = GND	5	5.4		V
V _{OL}	Low-level output voltage	DOOUT at R _L = 3 kΩ to GND, DIN = V _{CC}	-5	-5.4		V
I _{IH}	High-level input current	V _I = V _{CC}		±0.01	±1	μA
I _{IL}	Low-level input current	V _I at GND		±0.01	±1	μA
I _{OS}	Short-circuit output current ⁽³⁾	V _{CC} = 3.6 V, V _O = 0 V		±35	±60	mA
		V _{CC} = 5.5 V, V _O = 0 V		±35	±90	
r _o	Output resistance	V _{CC} , V+, and V- = 0 V, V _O = ±2 V	300	10M		Ω
I _{off}	Output leakage current	FORCEOFF = GND	V _O = ±12 V, V _{CC} = 3 V to 3.6 V		±25	μA
			V _O = ±10 V, V _{CC} = 4.5 V to 5.5 V		±25	

- (1) Test conditions are C1–C4 = 0.1 μF at V_{CC} = 3.3 V ± 0.3 V; C1 = 0.047 μF, C2–C4 = 0.33 μF at V_{CC} = 5 V ± 0.5 V.
(2) All typical values are at V_{CC} = 3.3 V or V_{CC} = 5 V, and T_A = 25°C.
(3) Short-circuit durations must be controlled to prevent exceeding the device absolute power dissipation ratings, and not more than one output can be shorted at a time.

5.8 Switching Characteristics, Driver

over recommended ranges of supply voltage and operating free-air temperature (unless otherwise noted)
(see [8-1](#))

PARAMETER		TEST CONDITIONS ⁽¹⁾		MIN	TYP ⁽²⁾	MAX	UNIT
Maximum data rate (see 6-1)	R _L = 3 kΩ	C _L = 1000 pF		250			kbit/s
		C _L = 250 pF, V _{CC} = 3 V to 4.5 V	1000				
		C _L = 1000 pF, V _{CC} = 4.5 V to 5.5 V	1000				
t _{sk(p)}	Pulse skew ⁽³⁾	C _L = 250 pF	R _L = 3 kΩ 6-2 RGT Package	25			ns
		C _L = 150 pF to 2500 pF,	R _L = 3 kΩ to 7 kΩ, See 6-2 DB or PW package	100			
SR(tr)	Slew rate, transition region (see 6-1)	V _{CC} = 3.3 V,	R _L = 3 kΩ to 7 kΩ, C _L = 150 pF to 1000 pF	18		150	V/μs

- (1) Test conditions are C1–C4 = 0.1 μF at V_{CC} = 3.3 V ± 0.3 V; C1 = 0.047 μF, C2–C4 = 0.33 μF at V_{CC} = 5 V ± 0.5 V.
(2) All typical values are at V_{CC} = 3.3 V or V_{CC} = 5 V, and T_A = 25°C.
(3) Pulse skew is defined as |t_{PLH} - t_{PHL}| of each channel of the same device.

5.9 Electrical Characteristics, Receiver

over recommended ranges of supply voltage and operating free-air temperature (unless otherwise noted)
(see [8-1](#))

PARAMETER		TEST CONDITIONS ⁽¹⁾	MIN	TYP ⁽²⁾	MAX	UNIT
V _{OH}	High-level output voltage	I _{OH} = -1 mA	V _{CC} - 0.6 V	V _{CC} - 0.1 V		V
V _{OL}	Low-level output voltage	I _{OL} = 1.6 mA			0.4	V
V _{IT+}	Positive-going input threshold voltage	V _{CC} = 3.3 V		1.6	2.4	V
		V _{CC} = 5 V		1.9	2.4	
V _{IT-}	Negative-going input threshold voltage	V _{CC} = 3.3 V	0.6	1.1		V
		V _{CC} = 5 V	0.8	1.4		
V _{hys}	Input hysteresis (V _{IT+} - V _{IT-})			0.5		V
I _{off}	Output leakage current	FORCEOFF = 0 V		±0.05	±10	µA
r _i	Input resistance	V _i = ±3 V to ±25 V	3	5	7	kΩ

(1) Test conditions are C1–C4 = 0.1 µF at V_{CC} = 3.3 V ± 0.3 V; C1 = 0.047 µF, C2–C4 = 0.33 µF at V_{CC} = 5 V ± 0.5 V.

(2) All typical values are at V_{CC} = 3.3 V or V_{CC} = 5 V, and T_A = 25°C.

5.10 Switching Characteristics, Receiver

over recommended ranges of supply voltage and operating free-air temperature (unless otherwise noted)
(see [8-1](#))

PARAMETER		TEST CONDITIONS ⁽¹⁾	TYP ⁽²⁾	UNIT	
t _{PLH}	Propagation delay time, low- to high-level output	C _L = 150 pF, See 6-3	RGT package	100	ns
			DB or PW package	150	
t _{PHL}	Propagation delay time, high- to low-level output	C _L = 150 pF, See 6-3	RGT package	125	ns
			DB or PW package	150	
t _{en}	Output enable time	C _L = 150 pF, R _L = 3 kΩ, See 6-4	200	ns	
t _{dis}	Output disable time	C _L = 150 pF, R _L = 3 kΩ, See 6-4	200	ns	
t _{sk(p)}	Pulse skew ⁽³⁾	See 6-3	RGT package	25	ns
			DB or PW package	50	

(1) Test conditions are C1–C4 = 0.1 µF at V_{CC} = 3.3 V ± 0.3 V; C1 = 0.047 µF, C2–C4 = 0.33 µF at V_{CC} = 5 V ± 0.5 V.

(2) All typical values are at V_{CC} = 3.3 V or V_{CC} = 5 V, and T_A = 25°C.

(3) Pulse skew is defined as |t_{PLH} - t_{PHL}| of each channel of the same device.

5.11 Electrical Characteristics, Auto-Powerdown

over recommended ranges of supply voltage and operating free-air temperature (unless otherwise noted)
(see 6-5)

PARAMETER		TEST CONDITIONS		MIN	MAX	UNIT
V_{T+} (valid)	Receiver input threshold for $\overline{\text{INVALID}}$ high-level output voltage	FORCEON = GND,	FORCEOFF = V_{CC}		2.7	V
V_{T-} (valid)	Receiver input threshold for $\overline{\text{INVALID}}$ high-level output voltage	FORCEON = GND,	FORCEOFF = V_{CC}	-2.7		V
V_{T} (invalid)	Receiver input threshold for $\overline{\text{INVALID}}$ low-level output voltage	FORCEON = GND,	FORCEOFF = V_{CC}	-0.3	0.3	V
V_{OH}	$\overline{\text{INVALID}}$ high-level output voltage	$I_{OH} = -1 \text{ mA}$, FORCEON = GND,	FORCEOFF = V_{CC}	$V_{CC} - 0.6$		V
V_{OL}	$\overline{\text{INVALID}}$ low-level output voltage	$I_{OL} = 1.6 \text{ mA}$, FORCEON = GND,	FORCEOFF = V_{CC}		0.4	V

5.12 Switching Characteristics, Auto-Powerdown

over recommended ranges of supply voltage and operating free-air temperature (unless otherwise noted)
(see 6-5)

PARAMETER		TYP ⁽¹⁾	UNIT
t_{valid}	Propagation delay time, low- to high-level output	1	μs
t_{invalid}	Propagation delay time, high- to low-level output	30	μs
t_{en}	Supply enable time	100	μs

(1) All typical values are at $V_{CC} = 3.3 \text{ V}$ or $V_{CC} = 5 \text{ V}$, and $T_A = 25^\circ\text{C}$.

5.13 Typical Characteristics

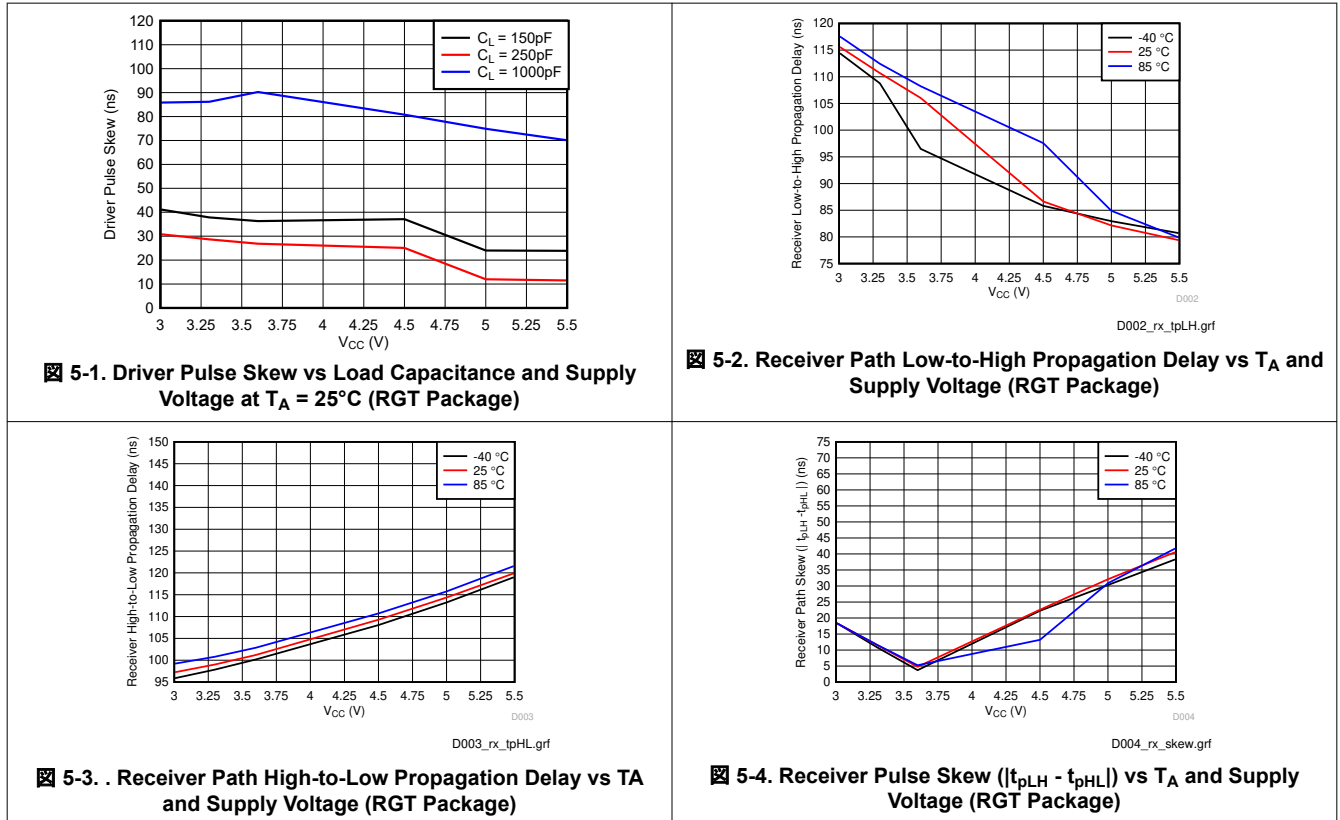

6 Parameter Measurement Information

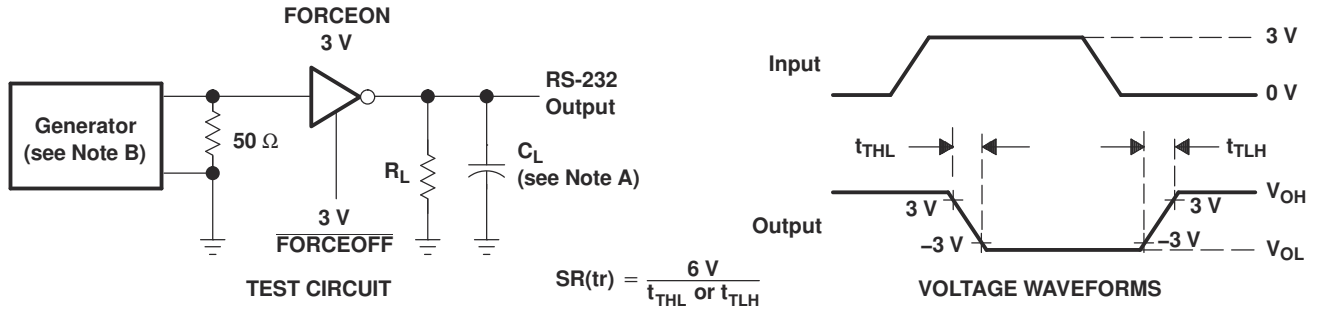

NOTES: A. C_L includes probe and jig capacitance.
B. The pulse generator has the following characteristics: PRR = 250 kbit/s, $Z_O = 50\ \Omega$, 50% duty cycle, $t_r \leq 10\text{ ns}$, $t_f \leq 10\text{ ns}$.

图 6-1. Driver Slew Rate

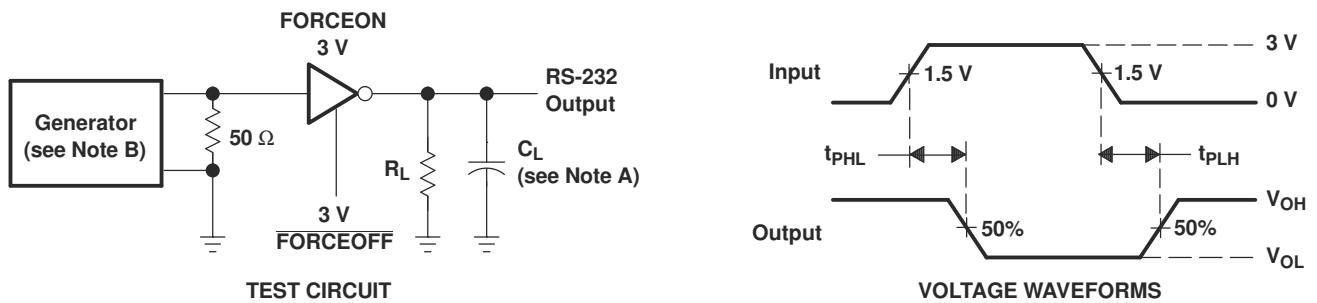

NOTES: A. C_L includes probe and jig capacitance.
B. The pulse generator has the following characteristics: PRR = 250 kbit/s, $Z_O = 50\ \Omega$, 50% duty cycle, $t_r \leq 10\text{ ns}$, $t_f \leq 10\text{ ns}$.

图 6-2. Driver Pulse Skew

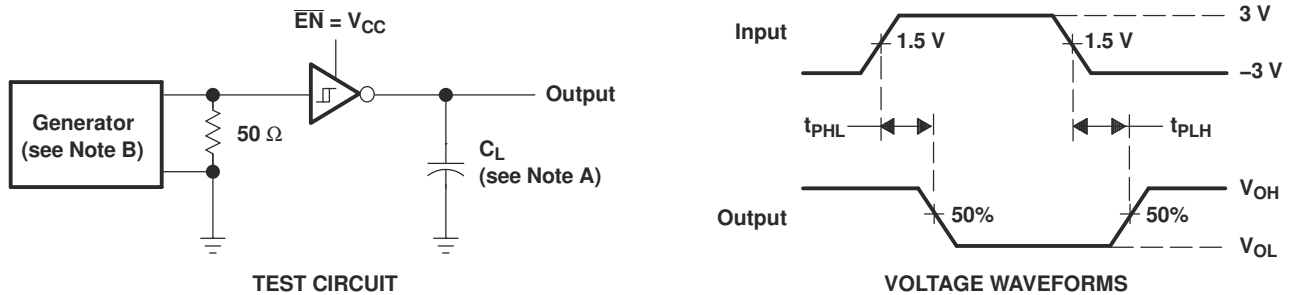

NOTES: A. C_L includes probe and jig capacitance.
B. The pulse generator has the following characteristics: $Z_O = 50\ \Omega$, 50% duty cycle, $t_r \leq 10\text{ ns}$, $t_f \leq 10\text{ ns}$.

图 6-3. Receiver Propagation Delay Times

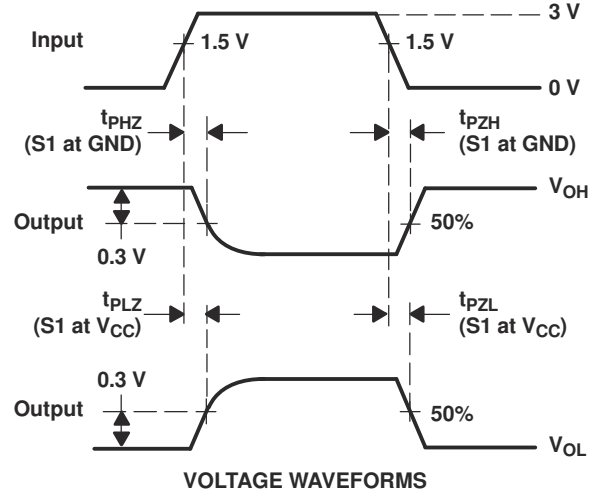
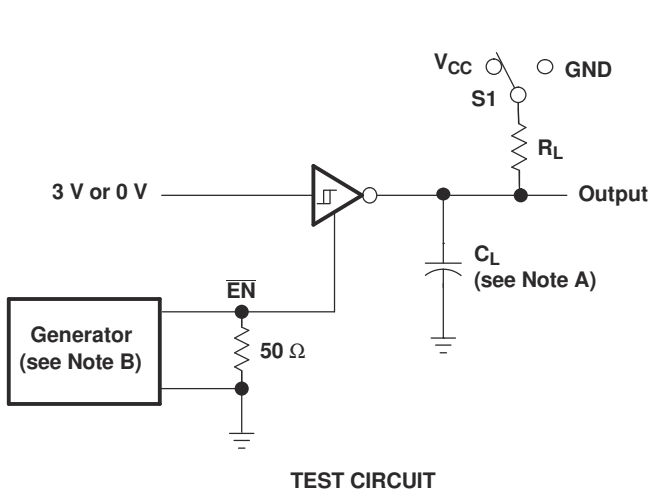

- NOTES: A. C_L includes probe and jig capacitance.
 B. The pulse generator has the following characteristics: $Z_O = 50 \Omega$, 50% duty cycle, $t_r \leq 10 \text{ ns}$, $t_f \leq 10 \text{ ns}$.
 C. t_{PLZ} and t_{PHZ} are the same as t_{dis} .
 D. t_{PZL} and t_{PZH} are the same as t_{en} .

6-4. Receiver Enable and Disable Times

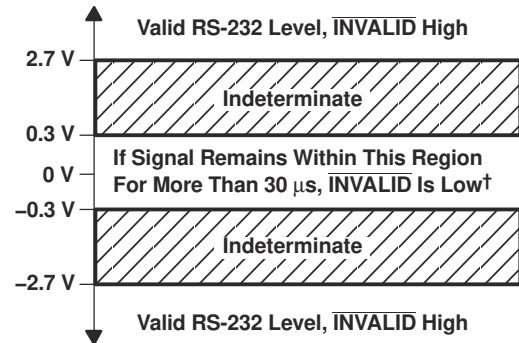
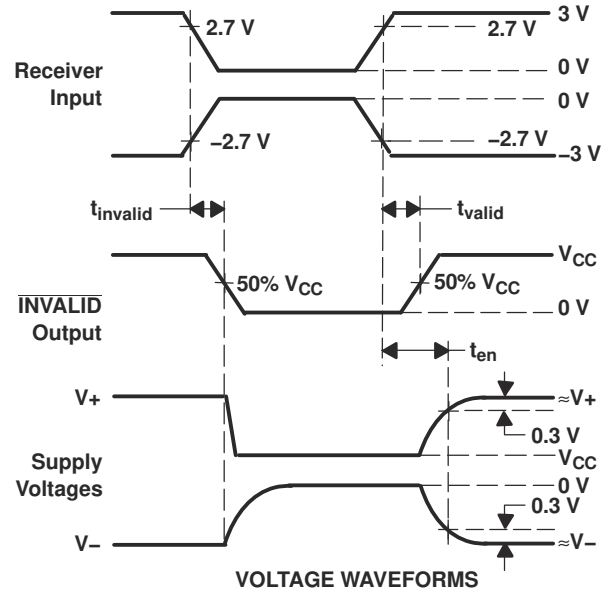
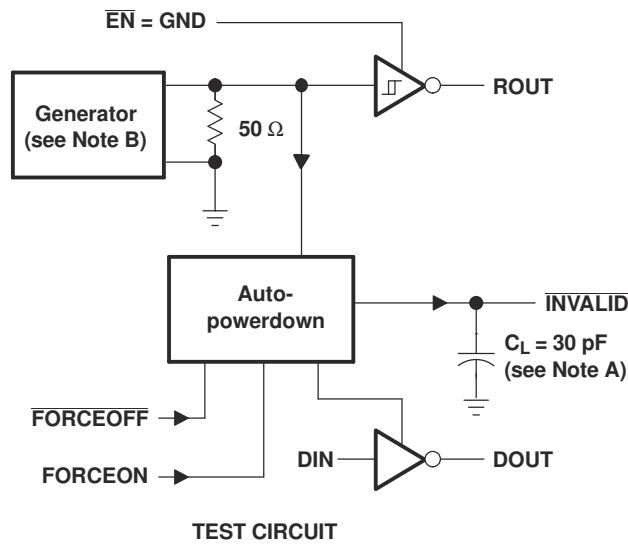

† Auto-powerdown disables drivers and reduces supply current to 1 μA.

NOTES: A. CL includes probe and jig capacitance.

B. The pulse generator has the following characteristics: PRR = 5 kbit/s, ZO = 50 Ω, 50% duty cycle, tr ≤ 10 ns, tf ≤ 10 ns.

6-5. INVALID Propagation Delay Times and Driver Enabling Time

7 Detailed Description

7.1 Overview

The TRSF3221E consists of one line driver, one line receiver, and a dual charge-pump circuit with $\pm 15\text{kV}$ IEC ESD protection pin to pin (serial-port connection pins, including GND). The TRSF3221E provides the electrical interface between an asynchronous communication controller and the serial-port connector. The charge pump and four small external capacitors allow operation from a single 3V to 5.5V supply. The TRSF3221E operates at data signaling rates up to 1Mbit/s and a driver output slew rate of $24\text{V}/\mu\text{s}$ to $150\text{V}/\mu\text{s}$.

Flexible control options for power management are available when the serial port is inactive. The auto-powerdown feature functions when FORCEON is low and $\overline{\text{FORCEOFF}}$ is high. During this mode of operation, if the TRSF3221E does not sense a valid RS-232 signal on the receiver input, the driver output is disabled. If $\overline{\text{FORCEOFF}}$ is set low and the enable ($\overline{\text{EN}}$) input is high, both the driver and receiver are shut off, and the supply current is reduced to $1\mu\text{A}$. Disconnecting the serial port or turning off the peripheral drivers causes the auto-powerdown condition to occur. Auto-powerdown can be disabled when FORCEON and $\overline{\text{FORCEOFF}}$ are high. With auto-powerdown enabled, the device is activated automatically when a valid signal is applied to the receiver input. The $\overline{\text{INVALID}}$ output notifies the user if an RS-232 signal is present at the receiver input. $\overline{\text{INVALID}}$ is high (valid data) if the receiver input voltage is greater than 2.7V or less than -2.7V , or has been between -0.3V and 0.3V for less than $30\mu\text{s}$. $\overline{\text{INVALID}}$ is low (invalid data) if the receiver input voltage is between -0.3V and 0.3V for more than $30\mu\text{s}$. Outputs are protected against shorts to ground.

7.2 Functional Block Diagram



図 7-1. Logic Diagram (Positive Logic)

7.3 Feature Description

The power block increases, inverts, and regulates voltage at $V+$ and $V-$ pins using a charge pump that requires four external capacitors. Auto-power-down feature for driver is controlled by FORCEON and FORCEOFF inputs. Receiver is controlled by $\overline{\text{EN}}$ input. When MAX3221E is unpowered, it can be safely connected to an active remote RS-232 device.

The driver interfaces the standard logic level to RS232 voltage levels. The DIN input must be valid high or low.

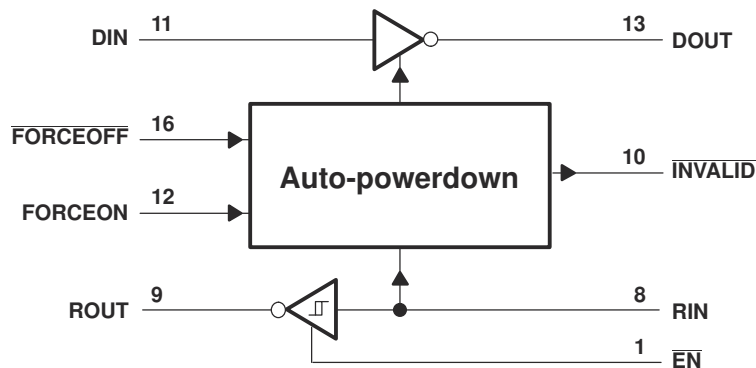
The receiver interfaces RS-232 levels to standard logic levels. An open input results in a high output on ROUT. RIN input includes an internal standard RS-232 load. A logic high input on the $\overline{\text{EN}}$ pin shuts down the receiver output.

7.4 Device Functional Modes

Functional Tables, Each Driver

INPUTS ⁽¹⁾				OUTPUT DOUT	DRIVER STATUS
DIN	FORCEON	FORCEOFF	VALID RIN RS-232 LEVEL		
X	X	L	X	Z	Powered off
L	H	H	X	H	Normal operation with auto-powerdown disabled
H	H	H	X	L	
L	L	H	Yes	H	Normal operation with auto-powerdown enabled
H	L	H	Yes	L	
L	L	H	No	Z	Powered off by auto-powerdown feature
H	L	H	No	Z	

(1) H = high level, L = low level, X = irrelevant, Z = high impedance

Each Receiver

INPUTS ⁽¹⁾			OUTPUT ROUT
RIN	EN	VALID RIN RS-232 LEVEL	
L	L	X	H
H	L	X	L
X	H	X	Z
Open	L	No	H

(1) H = high level, L = low level, X = irrelevant, Z = high impedance (off), Open = disconnected input or connected driver off

8 Application and Implementation

注

以下のアプリケーション情報は、TI の製品仕様に含まれるものではなく、TI ではその正確性または完全性を保証いたしません。個々の目的に対する製品の適合性については、お客様の責任で判断していただくこととなります。お客様は自身の設計実装を検証しテストすることで、システムの機能を確認する必要があります。

8.1 Application Information

The TRSF3221E line driver and receiver is a specialized device for 3V to 5.5V RS-232 communication applications. This application is a generic implementation of this device with all required external components. For proper operation, add capacitors as shown in 表 8-1.

8.1.1 Typical Application

ROUT and DIN connect to UART or general purpose logic lines. FORCEON and $\overline{\text{FORCEOFF}}$ may be connected general purpose logic lines or tied to ground or VCC. $\overline{\text{INVALID}}$ may be connected to a general purpose logic line or left unconnected. RIN and DOUT lines connect to a RS-232 connector or cable. DIN, FORCEON, and $\overline{\text{FORCEOFF}}$ inputs must not be left unconnected.

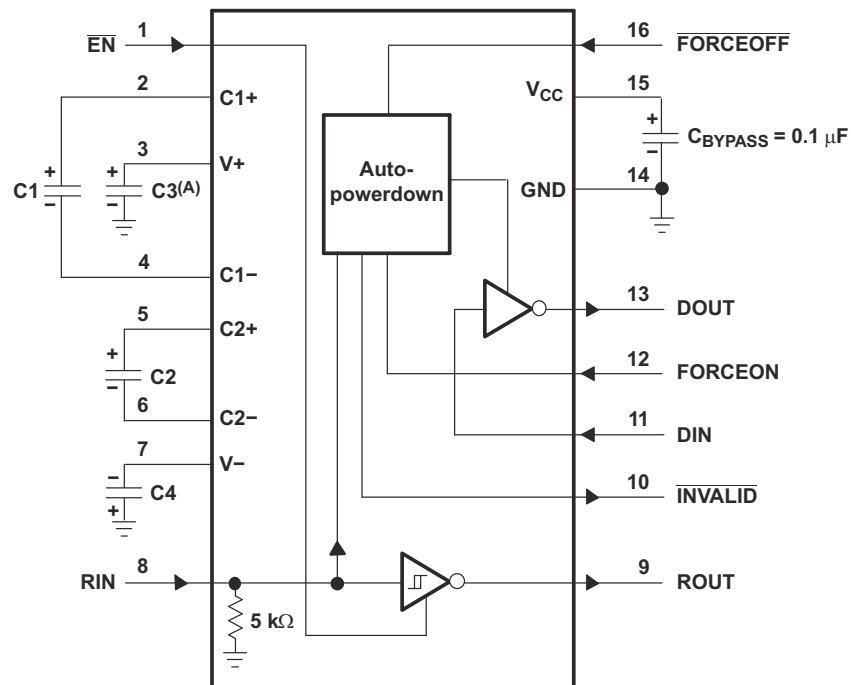

- A. C3 can be connected to V_{CC} or GND.
- B. Resistor values shown are nominal.
- C. Nonpolarized ceramic capacitors are acceptable. If polarized tantalum or electrolytic capacitors are used, they must be connected as shown.

図 8-1. Typical Operating Circuit and Capacitor Values

表 8-1. V_{CC} vs Capacitor Values

V _{CC}	C1	C2, C3, C4
3.3V ± 0.3V	0.1μF	0.1μF
5V ± 0.5V	0.047μF	0.33μF
3V to 5.5V	0.1μF	0.47μF

8.1.1.1 Design Requirements

- Recommended VCC is 3.3V or 5V – 3V to 5.5V is also possible
- Maximum recommended bit rate is 1Mbps
- Use capacitors as shown in [図 8-1](#) and [表 8-1](#)

8.1.1.2 Detailed Design Procedure

For proper operation:

- DIN, FORCEOFF and FORCEON inputs must be connected to valid low or high logic levels
- Select capacitor values based on VCC level for best performance

ROUT and DIN connect to UART or general purpose logic lines. FORCEON and FORCEOFF may be connected general purpose logic lines or tied to ground or VCC. INVALID may be connected to a general purpose logic line or left unconnected. RIN and DOUT lines connect to a RS232 connector or cable. DIN, FORCEON, and FORCEOFF inputs must not be left unconnected.

8.1.2 Application Performance Plot



図 8-2. 1 Mbps Driver to Receiver Loopback Timing Waveform, V_{CC} = 3.3 V

8.2 Power Supply Recommendations

V_{CC} must be between 3V and 5.5V. Charge pump capacitors must be chosen using [V_{CC} vs Capacitor Values](#).

8.3 Layout

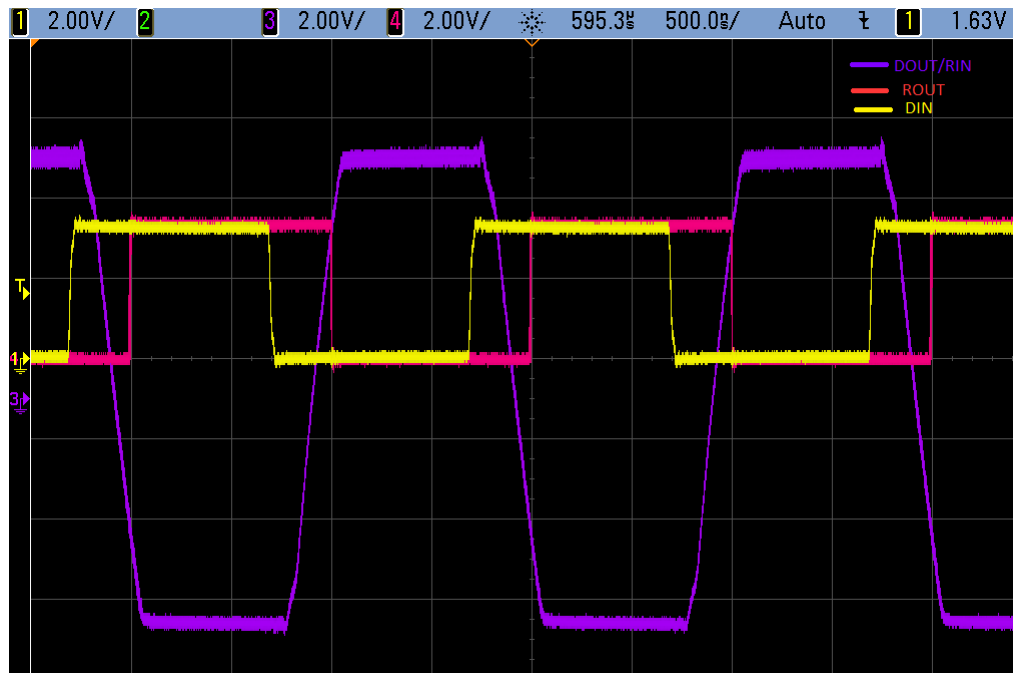
8.3.1 Layout Guidelines

Keep the external capacitor traces short. This is more important on C1 and C2 nodes, which have the fastest rise and fall times.

8.3.2 Layout Example

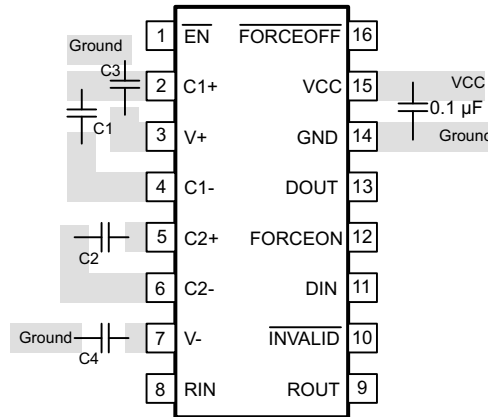

8-3. Layout Diagram

9 Device and Documentation Support

9.1 ドキュメントの更新通知を受け取る方法

ドキュメントの更新についての通知を受け取るには、www.tij.co.jp のデバイス製品フォルダを開いてください。[通知] をクリックして登録すると、変更されたすべての製品情報に関するダイジェストを毎週受け取ることができます。変更の詳細については、改訂されたドキュメントに含まれている改訂履歴をご覧ください。

9.2 サポート・リソース

テキサス・インスツルメンツ E2E™ サポート・フォーラムは、エンジニアが検証済みの回答と設計に関するヒントをエキスパートから迅速かつ直接得ることができる場所です。既存の回答を検索したり、独自の質問をしたりすることで、設計に必要な支援を迅速に得ることができます。

リンクされているコンテンツは、各寄稿者により「現状のまま」提供されるものです。これらはテキサス・インスツルメンツの仕様を構成するものではなく、必ずしもテキサス・インスツルメンツの見解を反映したものではありません。テキサス・インスツルメンツの[使用条件](#)を参照してください。

9.3 商標

テキサス・インスツルメンツ E2E™ is a trademark of Texas Instruments.

すべての商標は、それぞれの所有者に帰属します。

9.4 静電気放電に関する注意事項



この IC は、ESD によって破損する可能性があります。テキサス・インスツルメンツは、IC を取り扱う際には常に適切な注意を払うことを推奨します。正しい取り扱いおよび設置手順に従わない場合、デバイスを破損するおそれがあります。

ESD による破損は、わずかな性能低下からデバイスの完全な故障まで多岐にわたります。精密な IC の場合、パラメータがわずかに変化するだけで公表されている仕様から外れる可能性があるため、破損が発生しやすくなっています。

9.5 用語集

[テキサス・インスツルメンツ用語集](#) この用語集には、用語や略語の一覧および定義が記載されています。

10 Revision History

資料番号末尾の英字は改訂を表しています。その改訂履歴は英語版に準じています。

Changes from Revision B (July 2021) to Revision C (December 2024)	Page
• 「製品情報」表を「パッケージ情報」表に変更.....	1
• データシートに SOT-23-THN (DYY) パッケージを追加.....	1
• Added Note 2 to the ESD Ratings, IEC Specifications	5

Changes from Revision A (May 2021) to Revision B (July 2021)	Page
• 「アプリケーション」の一覧を変更.....	1
• Changed the table note for the ESD Ratings, IEC Specifications table to make it also applicable to PW package.....	5
• Changed the thermal information for PW package.....	6

Changes from Revision * (August 2007) to Revision A (May 2021)	Page
• 「製品情報」表、「ESD 定格」表、「機能説明」セクション、「デバイスの機能モード」セクション、「アプリケーションと実装」セクション、「電源に関する推奨事項」セクション、「レイアウト」セクション、「デバイスおよびドキュメントのサポート」セクション、「メカニカル、パッケージ、および注文情報」セクションを追加.....	1

11 Mechanical, Packaging, and Orderable Information

The following pages include mechanical, packaging, and orderable information. This information is the most current data available for the designated devices. This data is subject to change without notice and revision of this document. For browser-based versions of this data sheet, refer to the left-hand navigation.

PACKAGING INFORMATION

Orderable part number	Status (1)	Material type (2)	Package Pins	Package qty Carrier	RoHS (3)	Lead finish/ Ball material (4)	MSL rating/ Peak reflow (5)	Op temp (°C)	Part marking (6)
TRSF3221ECDB	Obsolete	Production	SSOP (DB) 16	-	-	Call TI	Call TI	0 to 70	RT21EC
TRSF3221ECDBR	Active	Production	SSOP (DB) 16	2000 LARGE T&R	Yes	NIPDAU	Level-1-260C-UNLIM	0 to 70	RT21EC
TRSF3221ECDBR.A	Active	Production	SSOP (DB) 16	2000 LARGE T&R	Yes	NIPDAU	Level-1-260C-UNLIM	0 to 70	RT21EC
TRSF3221ECPWR	Active	Production	TSSOP (PW) 16	2000 LARGE T&R	Yes	NIPDAU SN	Level-1-260C-UNLIM	0 to 70	RT21EC
TRSF3221ECPWR.A	Active	Production	TSSOP (PW) 16	2000 LARGE T&R	Yes	NIPDAU	Level-1-260C-UNLIM	0 to 70	RT21EC
TRSF3221EIDBR	Active	Production	SSOP (DB) 16	2000 LARGE T&R	Yes	NIPDAU	Level-1-260C-UNLIM	-40 to 85	RT21EI
TRSF3221EIDBR.A	Active	Production	SSOP (DB) 16	2000 LARGE T&R	Yes	NIPDAU	Level-1-260C-UNLIM	-40 to 85	RT21EI
TRSF3221EIDYYR	Active	Production	SOT-23-THIN (DYY) 16	3000 LARGE T&R	Yes	NIPDAU	Level-1-260C-UNLIM	-40 to 85	RT21EI
TRSF3221EIDYYR.A	Active	Production	SOT-23-THIN (DYY) 16	3000 LARGE T&R	Yes	NIPDAU	Level-1-260C-UNLIM	-40 to 85	RT21EI
TRSF3221EIPWR	Active	Production	TSSOP (PW) 16	2000 LARGE T&R	Yes	NIPDAU SN	Level-1-260C-UNLIM	-40 to 85	RT21EI
TRSF3221EIPWR.A	Active	Production	TSSOP (PW) 16	2000 LARGE T&R	Yes	NIPDAU	Level-1-260C-UNLIM	-40 to 85	RT21EI
TRSF3221EIRGTR	Active	Production	VQFN (RGT) 16	3000 LARGE T&R	Yes	SN	Level-1-260C-UNLIM	-40 to 85	F3221
TRSF3221EIRGTR.A	Active	Production	VQFN (RGT) 16	3000 LARGE T&R	Yes	SN	Level-1-260C-UNLIM	-40 to 85	F3221

(1) **Status:** For more details on status, see our [product life cycle](#).

(2) **Material type:** When designated, preproduction parts are prototypes/experimental devices, and are not yet approved or released for full production. Testing and final process, including without limitation quality assurance, reliability performance testing, and/or process qualification, may not yet be complete, and this item is subject to further changes or possible discontinuation. If available for ordering, purchases will be subject to an additional waiver at checkout, and are intended for early internal evaluation purposes only. These items are sold without warranties of any kind.

(3) **RoHS values:** Yes, No, RoHS Exempt. See the [TI RoHS Statement](#) for additional information and value definition.

(4) **Lead finish/Ball material:** Parts may have multiple material finish options. Finish options are separated by a vertical ruled line. Lead finish/Ball material values may wrap to two lines if the finish value exceeds the maximum column width.

(5) **MSL rating/Peak reflow:** The moisture sensitivity level ratings and peak solder (reflow) temperatures. In the event that a part has multiple moisture sensitivity ratings, only the lowest level per JEDEC standards is shown. Refer to the shipping label for the actual reflow temperature that will be used to mount the part to the printed circuit board.

(6) **Part marking:** There may be an additional marking, which relates to the logo, the lot trace code information, or the environmental category of the part.

Multiple part markings will be inside parentheses. Only one part marking contained in parentheses and separated by a "-" will appear on a part. If a line is indented then it is a continuation of the previous line and the two combined represent the entire part marking for that device.

Important Information and Disclaimer: The information provided on this page represents TI's knowledge and belief as of the date that it is provided. TI bases its knowledge and belief on information provided by third parties, and makes no representation or warranty as to the accuracy of such information. Efforts are underway to better integrate information from third parties. TI has taken and continues to take reasonable steps to provide representative and accurate information but may not have conducted destructive testing or chemical analysis on incoming materials and chemicals. TI and TI suppliers consider certain information to be proprietary, and thus CAS numbers and other limited information may not be available for release.

In no event shall TI's liability arising out of such information exceed the total purchase price of the TI part(s) at issue in this document sold by TI to Customer on an annual basis.

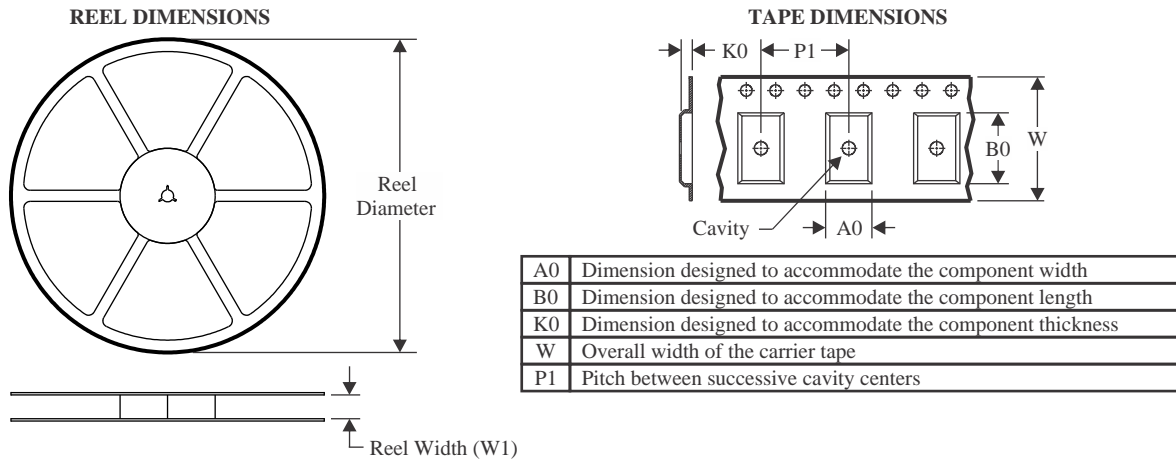
TAPE AND REEL INFORMATION

QUADRANT ASSIGNMENTS FOR PIN 1 ORIENTATION IN TAPE

*All dimensions are nominal

Device	Package Type	Package Drawing	Pins	SPQ	Reel Diameter (mm)	Reel Width W1 (mm)	A0 (mm)	B0 (mm)	K0 (mm)	P1 (mm)	W (mm)	Pin1 Quadrant
TRSF3221ECDBR	SSOP	DB	16	2000	330.0	16.4	8.35	6.6	2.4	12.0	16.0	Q1
TRSF3221ECPWR	TSSOP	PW	16	2000	330.0	12.4	6.9	5.6	1.6	8.0	12.0	Q1
TRSF3221EIDBR	SSOP	DB	16	2000	330.0	16.4	8.35	6.6	2.4	12.0	16.0	Q1
TRSF3221EIDYYR	SOT-23-THIN	DYY	16	3000	330.0	12.4	4.8	3.6	1.6	8.0	12.0	Q3
TRSF3221EIPWR	TSSOP	PW	16	2000	330.0	12.4	6.9	5.6	1.6	8.0	12.0	Q1
TRSF3221EIRGTR	VQFN	RGT	16	3000	330.0	12.4	3.3	3.3	1.1	8.0	12.0	Q2

TAPE AND REEL BOX DIMENSIONS

*All dimensions are nominal

Device	Package Type	Package Drawing	Pins	SPQ	Length (mm)	Width (mm)	Height (mm)
TRSF3221ECDBR	SSOP	DB	16	2000	353.0	353.0	32.0
TRSF3221ECPWR	TSSOP	PW	16	2000	356.0	356.0	35.0
TRSF3221EIDBR	SSOP	DB	16	2000	353.0	353.0	32.0
TRSF3221EIDYYR	SOT-23-THIN	DYY	16	3000	336.6	336.6	31.8
TRSF3221EIPWR	TSSOP	PW	16	2000	356.0	356.0	35.0
TRSF3221EIRGTR	VQFN	RGT	16	3000	367.0	367.0	35.0

DB0016A



PACKAGE OUTLINE

SSOP - 2 mm max height

SMALL OUTLINE PACKAGE



4220763/A 05/2022

NOTES:

1. All linear dimensions are in millimeters. Any dimensions in parenthesis are for reference only. Dimensioning and tolerancing per ASME Y14.5M.
2. This drawing is subject to change without notice.
3. This dimension does not include mold flash, protrusions, or gate burrs. Mold flash, protrusions, or gate burrs shall not exceed 0.15 mm per side.
4. Reference JEDEC registration MO-150.

EXAMPLE BOARD LAYOUT

DB0016A

SSOP - 2 mm max height

SMALL OUTLINE PACKAGE



LAND PATTERN EXAMPLE
EXPOSED METAL SHOWN
SCALE: 10X



4220763/A 05/2022

NOTES: (continued)

- 5. Publication IPC-7351 may have alternate designs.
- 6. Solder mask tolerances between and around signal pads can vary based on board fabrication site.

EXAMPLE STENCIL DESIGN

DB0016A

SSOP - 2 mm max height

SMALL OUTLINE PACKAGE



SOLDER PASTE EXAMPLE
BASED ON 0.125 mm THICK STENCIL
SCALE: 10X

4220763/A 05/2022

NOTES: (continued)

7. Laser cutting apertures with trapezoidal walls and rounded corners may offer better paste release. IPC-7525 may have alternate design recommendations.
8. Board assembly site may have different recommendations for stencil design.

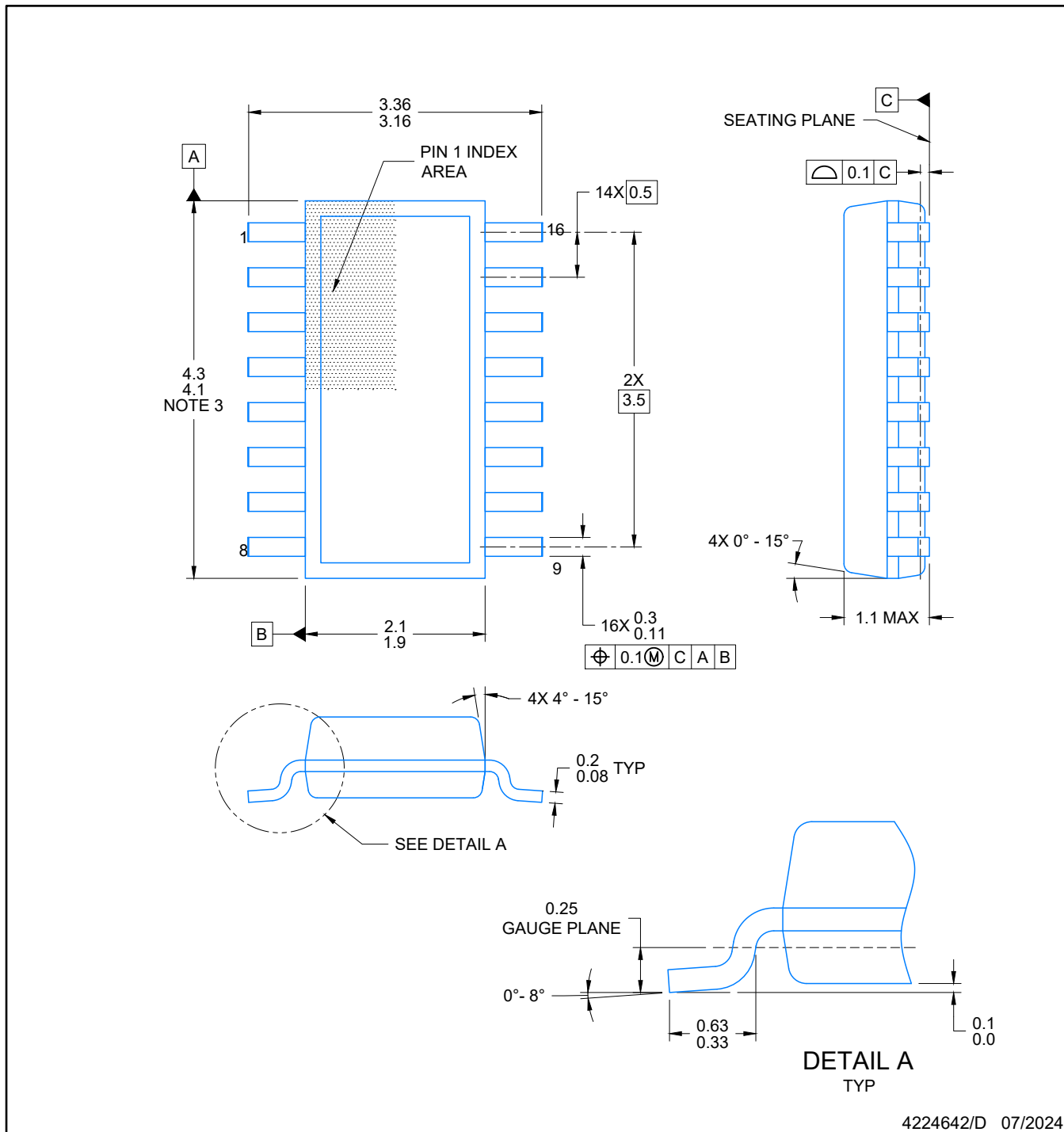

4224642/D 07/2024

NOTES:

1. All linear dimensions are in millimeters. Any dimensions in parenthesis are for reference only. Dimensioning and tolerancing per ASME Y14.5M.
2. This drawing is subject to change without notice.
3. This dimension does not include mold flash, protrusions, or gate burrs. Mold flash, protrusions, or gate burrs shall not exceed 0.15 per side.
4. This dimension does not include interlead flash. Interlead flash shall not exceed 0.50 per side.
5. Reference JEDEC Registration MO-345, Variation AA

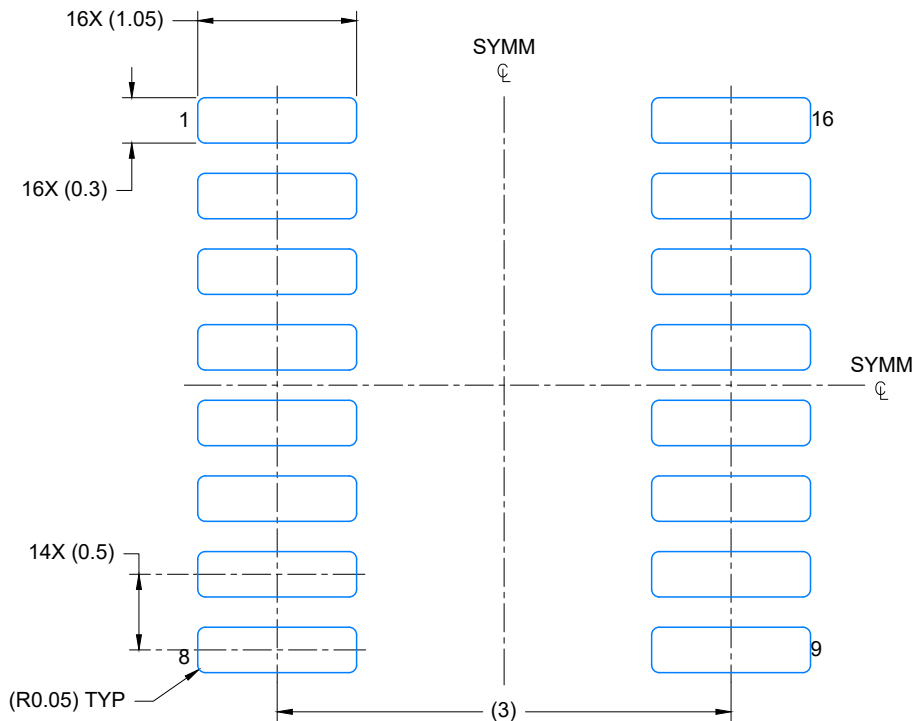

LAND PATTERN EXAMPLE
EXPOSED METAL SHOWN
SCALE: 20X

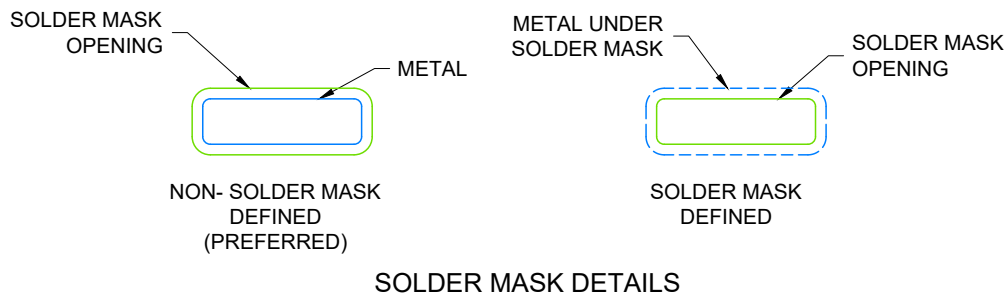

4224642/D 07/2024

NOTES: (continued)

- 6. Publication IPC-7351 may have alternate designs.
- 7. Solder mask tolerances between and around signal pads can vary based on board fabrication site.

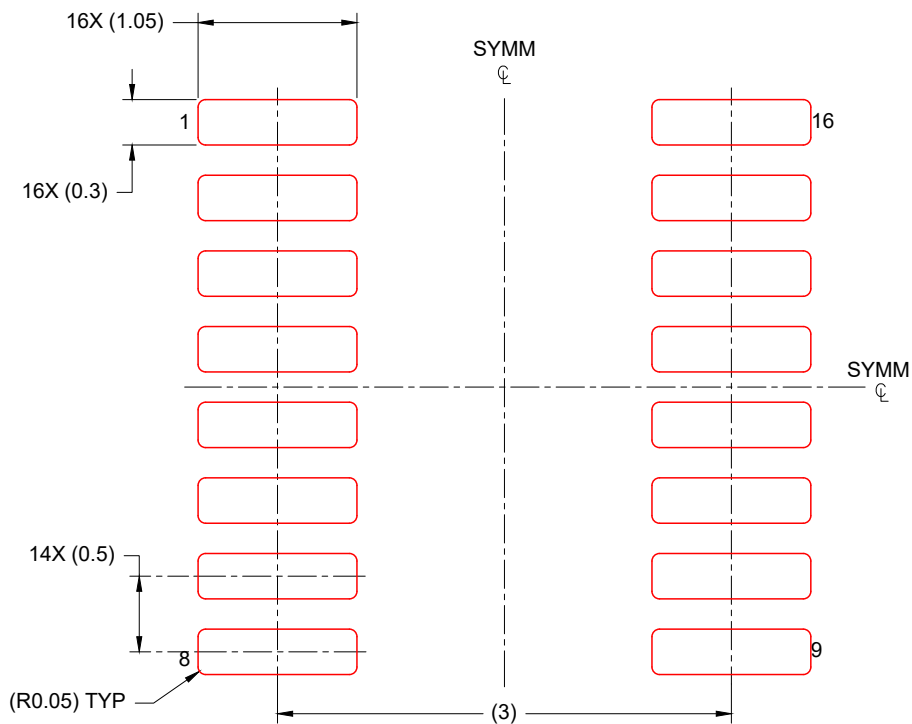

SOLDER PASTE EXAMPLE
BASED ON 0.125 mm THICK STENCIL
SCALE: 20X

4224642/D 07/2024

NOTES: (continued)

- 8. Laser cutting apertures with trapezoidal walls and rounded corners may offer better paste release. IPC-7525 may have alternate design recommendations.
- 9. Board assembly site may have different recommendations for stencil design.

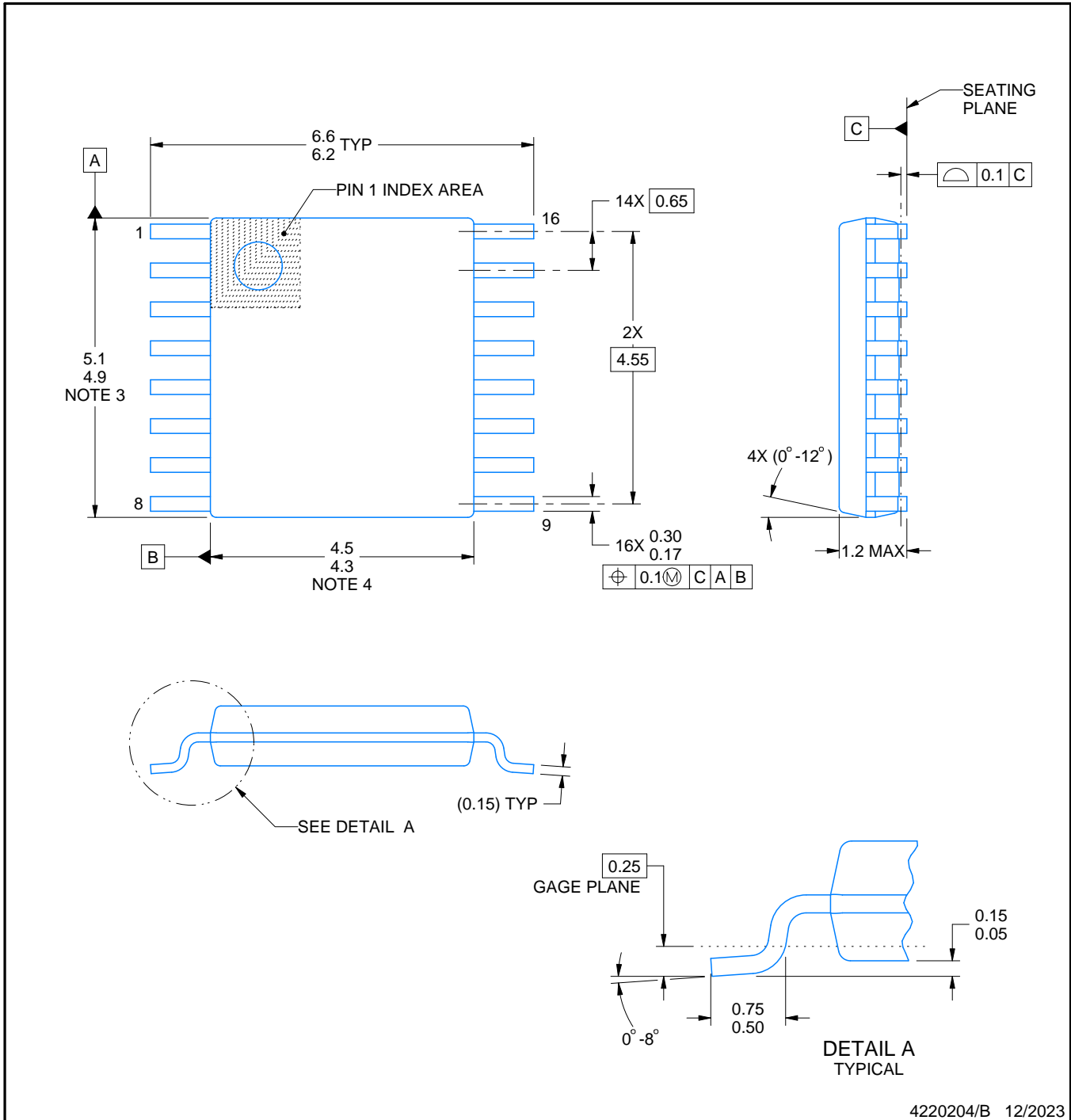

4220204/B 12/2023

NOTES:

1. All linear dimensions are in millimeters. Any dimensions in parenthesis are for reference only. Dimensioning and tolerancing per ASME Y14.5M.
2. This drawing is subject to change without notice.
3. This dimension does not include mold flash, protrusions, or gate burrs. Mold flash, protrusions, or gate burrs shall not exceed 0.15 mm per side.
4. This dimension does not include interlead flash. Interlead flash shall not exceed 0.25 mm per side.
5. Reference JEDEC registration MO-153.

EXAMPLE BOARD LAYOUT

PW0016A

TSSOP - 1.2 mm max height

SMALL OUTLINE PACKAGE

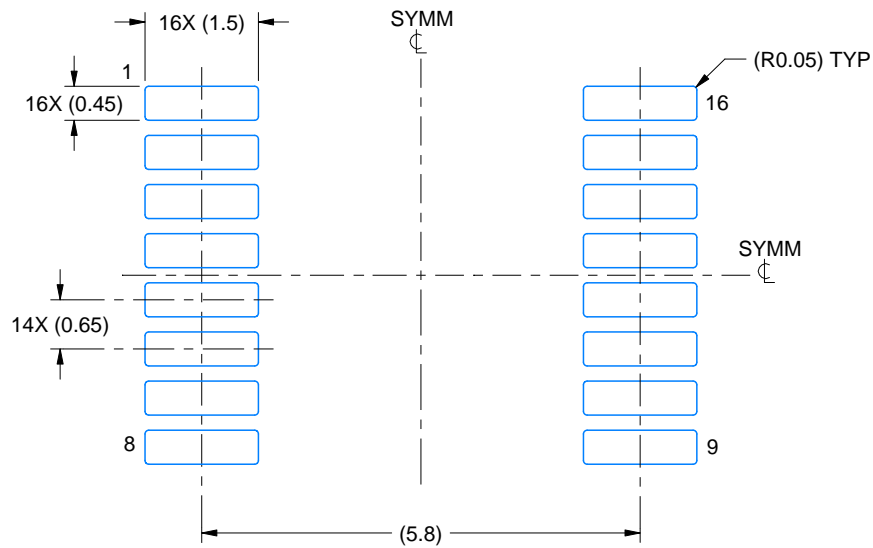

LAND PATTERN EXAMPLE
EXPOSED METAL SHOWN
SCALE: 10X



SOLDER MASK DETAILS

4220204/B 12/2023

NOTES: (continued)

- 6. Publication IPC-7351 may have alternate designs.
- 7. Solder mask tolerances between and around signal pads can vary based on board fabrication site.

EXAMPLE STENCIL DESIGN

PW0016A

TSSOP - 1.2 mm max height

SMALL OUTLINE PACKAGE

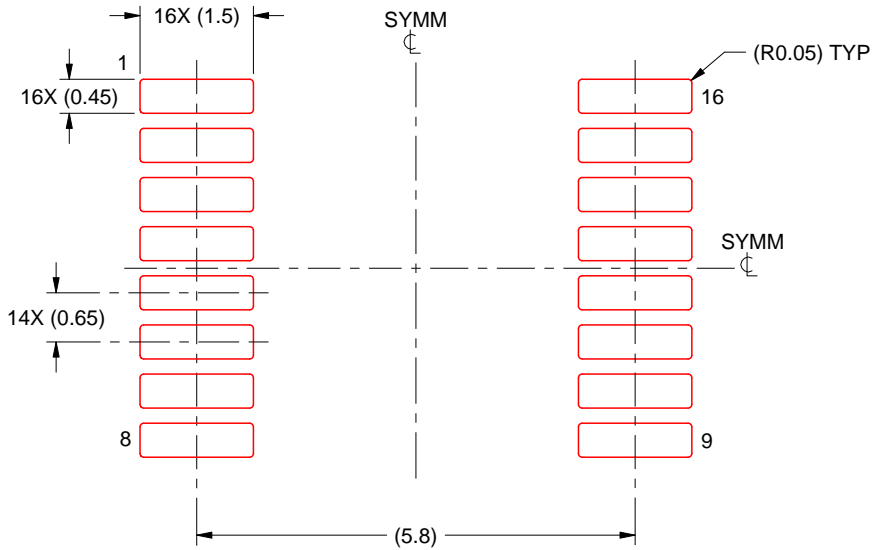

SOLDER PASTE EXAMPLE
BASED ON 0.125 mm THICK STENCIL
SCALE: 10X

4220204/B 12/2023

NOTES: (continued)

8. Laser cutting apertures with trapezoidal walls and rounded corners may offer better paste release. IPC-7525 may have alternate design recommendations.
9. Board assembly site may have different recommendations for stencil design.

RGT 16

GENERIC PACKAGE VIEW

VQFN - 1 mm max height

PLASTIC QUAD FLATPACK - NO LEAD

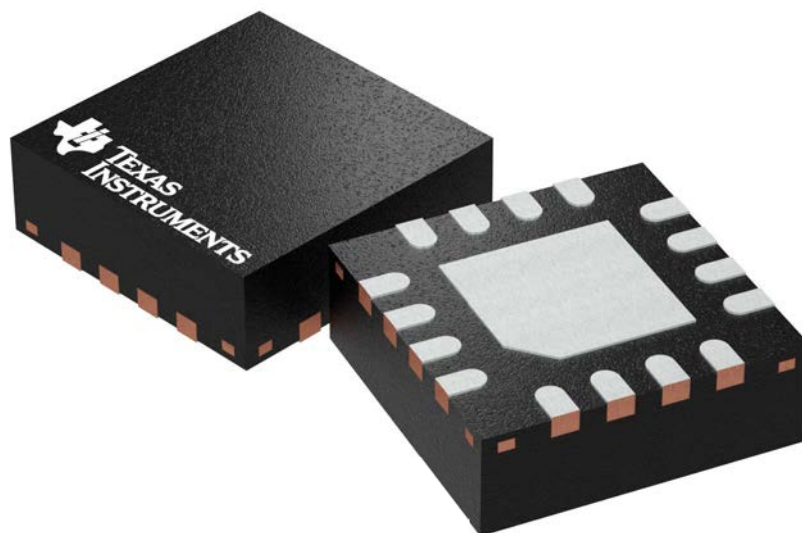

Images above are just a representation of the package family, actual package may vary.
Refer to the product data sheet for package details.

4203495/1

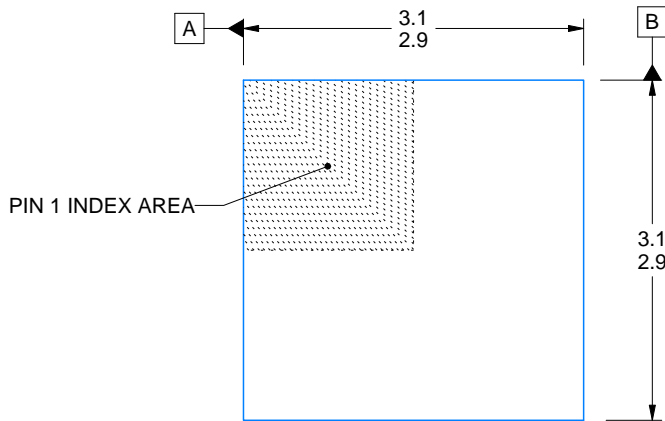
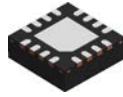

SIDE WALL METAL THICKNESS DIM A	
OPTION 1	OPTION 2
0.1	0.2

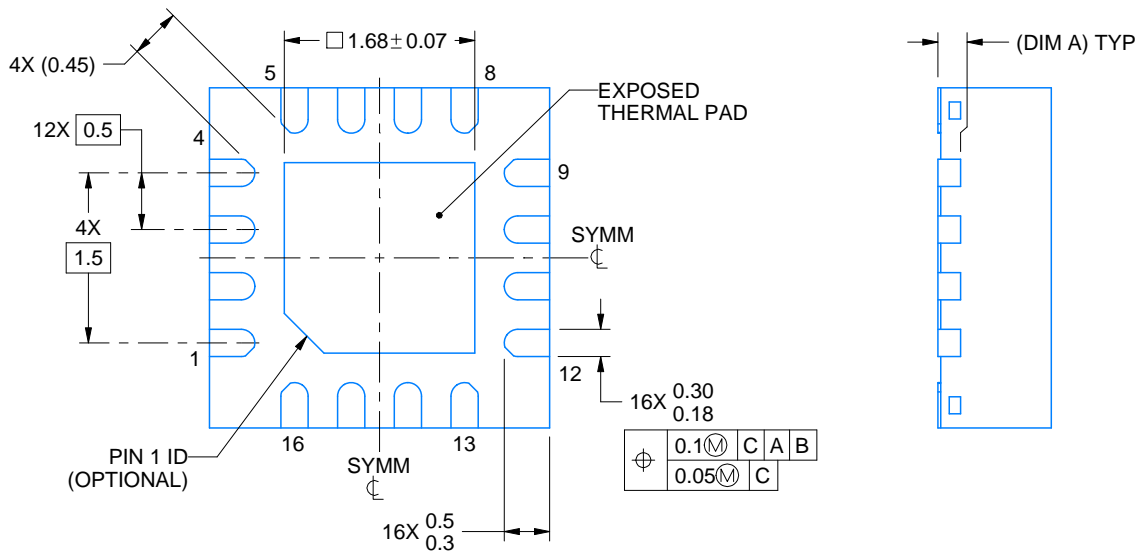
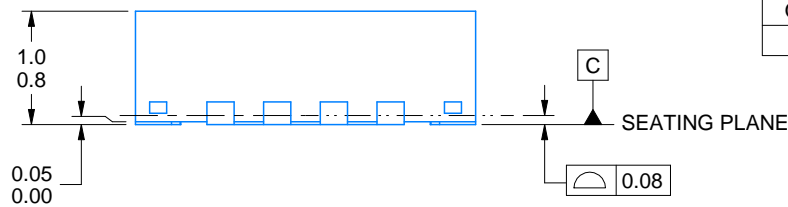

4222419/E 07/2025

NOTES:

1. All linear dimensions are in millimeters. Any dimensions in parenthesis are for reference only. Dimensioning and tolerancing per ASME Y14.5M.
2. This drawing is subject to change without notice.
3. The package thermal pad must be soldered to the printed circuit board for thermal and mechanical performance.

EXAMPLE BOARD LAYOUT

RGT0016C

VQFN - 1 mm max height

PLASTIC QUAD FLATPACK - NO LEAD

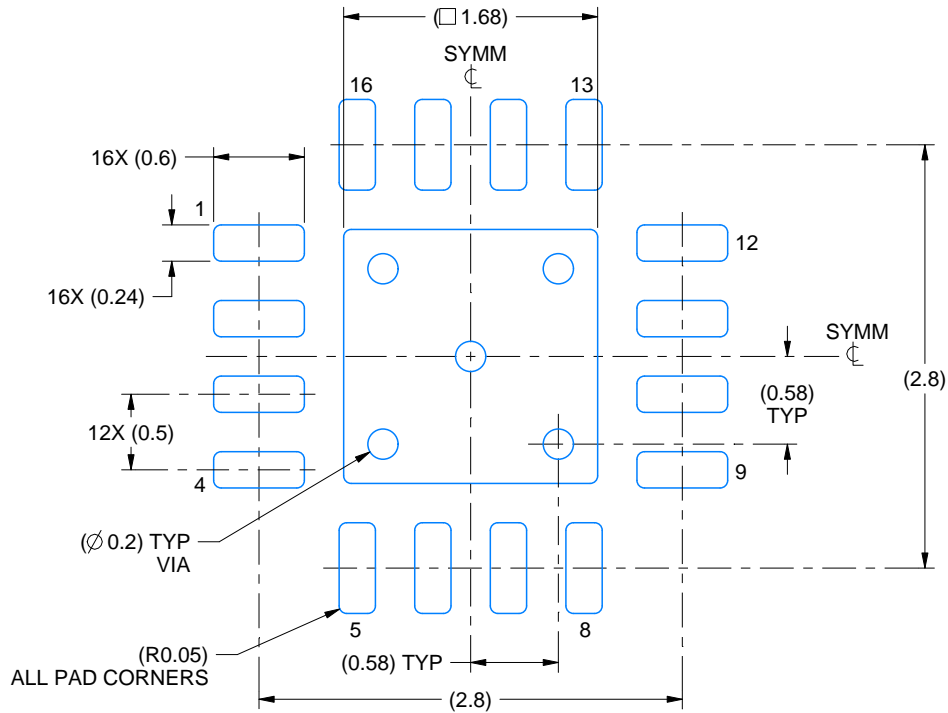

LAND PATTERN EXAMPLE
EXPOSED METAL SHOWN
SCALE:20X

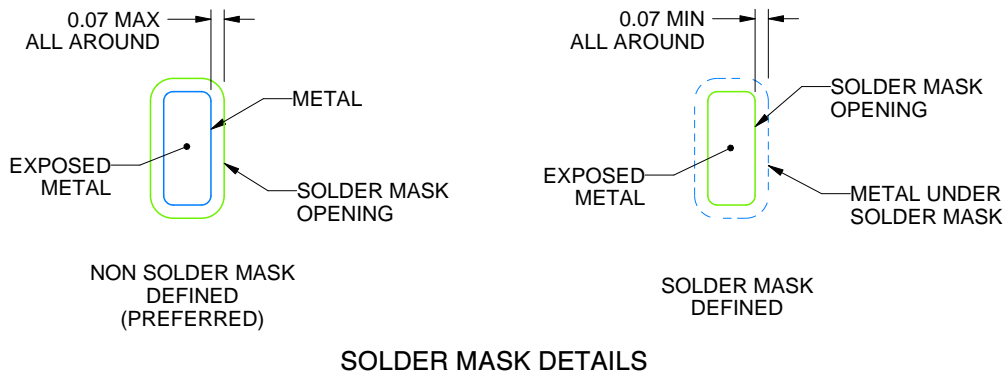

SOLDER MASK DETAILS

4222419/E 07/2025

NOTES: (continued)

4. This package is designed to be soldered to a thermal pad on the board. For more information, see Texas Instruments literature number SLUA271 (www.ti.com/lit/slua271).
5. Vias are optional depending on application, refer to device data sheet. If any vias are implemented, refer to their locations shown on this view. It is recommended that vias under paste be filled, plugged or tented.

EXAMPLE STENCIL DESIGN

RGT0016C

VQFN - 1 mm max height

PLASTIC QUAD FLATPACK - NO LEAD

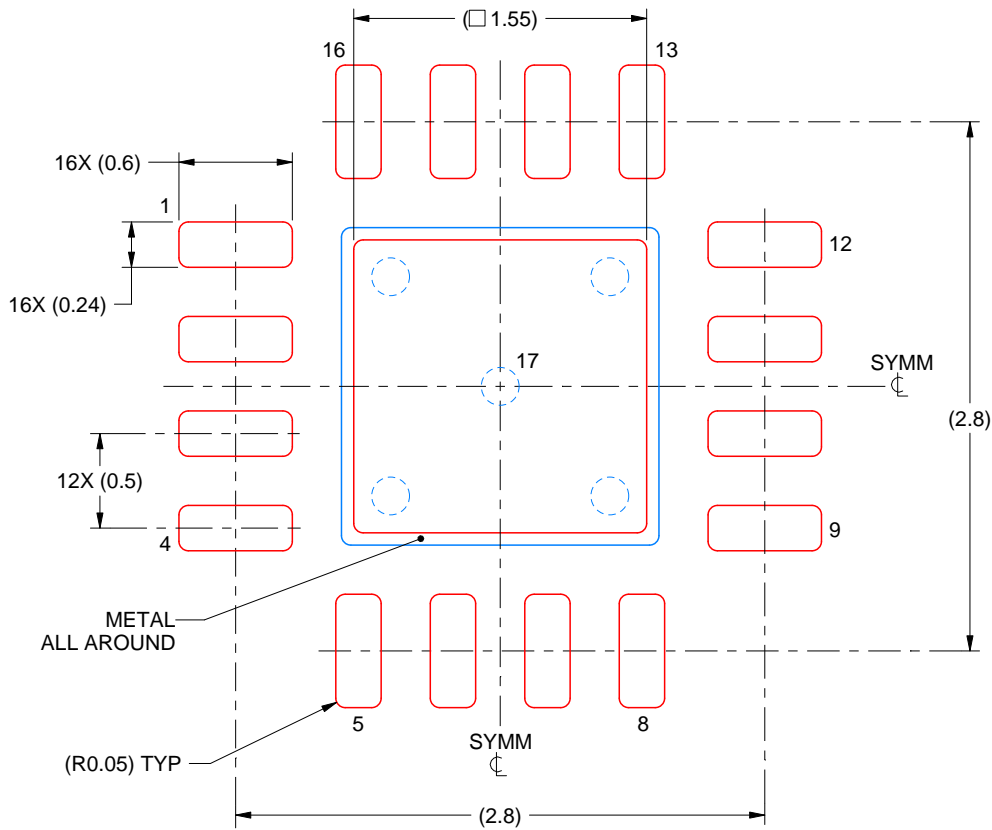

SOLDER PASTE EXAMPLE
BASED ON 0.125 mm THICK STENCIL

EXPOSED PAD 17:
85% PRINTED SOLDER COVERAGE BY AREA UNDER PACKAGE
SCALE:25X

4222419/E 07/2025

NOTES: (continued)

6. Laser cutting apertures with trapezoidal walls and rounded corners may offer better paste release. IPC-7525 may have alternate design recommendations.

重要なお知らせと免責事項

TI は、技術データと信頼性データ (データシートを含みます)、設計リソース (リファレンス デザインを含みます)、アプリケーションや設計に関する各種アドバイス、Web ツール、安全性情報、その他のリソースを、欠陥が存在する可能性のある「現状のまま」提供しており、商品性および特定目的に対する適合性の黙示保証、第三者の知的財産権の非侵害保証を含むいかなる保証も、明示的または黙示的にかかわらず拒否します。

これらのリソースは、TI 製品を使用する設計の経験を積んだ開発者への提供を意図したものです。(1) お客様のアプリケーションに適した TI 製品の選定、(2) お客様のアプリケーションの設計、検証、試験、(3) お客様のアプリケーションに該当する各種規格や、その他のあらゆる安全性、セキュリティ、規制、または他の要件への確実な適合に関する責任を、お客様のみが単独で負うものとし、

上記の各種リソースは、予告なく変更される可能性があります。これらのリソースは、リソースで説明されている TI 製品を使用するアプリケーションの開発の目的でのみ、TI はその使用をお客様に許諾します。これらのリソースに関して、他の目的で複製することや掲載することは禁止されています。TI や第三者の知的財産権のライセンスが付与されている訳ではありません。お客様は、これらのリソースを自身で使用した結果発生するあらゆる申し立て、損害、費用、損失、責任について、TI およびその代理人を完全に補償するものとし、TI は一切の責任を拒否します。

TI の製品は、[TI の販売条件](#)、[TI の総合的な品質ガイドライン](#)、[ti.com](#) または TI 製品などに関連して提供される他の適用条件に従い提供されます。TI がこれらのリソースを提供することは、適用される TI の保証または他の保証の放棄の拡大や変更を意味するものではありません。TI がカスタム、またはカスタマー仕様として明示的に指定していない限り、TI の製品は標準的なカタログに掲載される汎用機器です。

お客様がいかなる追加条項または代替条項を提案する場合も、TI はそれらに異議を唱え、拒否します。

Copyright © 2026, Texas Instruments Incorporated

最終更新日 : 2025 年 10 月