

TVS3301 33V 双方向フラット・クランプ・サージ保護デバイス

1 特長

- 機能安全対応
 - 機能安全システム的设计に役立つ資料を利用可能
- 産業用信号ライン向け 1kV、42Ω の IEC 61000-4-5 サージ・テストに耐える保護機能
- 双方向極性によりバイポーラ信号や誤配線に対して保護
- クランプ電圧: 40V (サージ電流 27A (8/20μs) 時)
- スタンドオフ電圧: ±33V
- 小型の 3mm × 3mm SON フットプリント
- 25A のサージ電流 (8/20μs) の反復ストライクを 5,000 回以上吸収
- 強力なサージ保護
 - IEC61000-4-5 (8/20μs): 27A
 - IEC61643-321 (10/1000μs): 3A
- 低いリーク電流
 - 27°C で 2.5nA (標準値)
 - 85°C で 450nA (最大値)
- 低い静電容量: 54pF
- レベル 4 IEC 61000-4-2 に準拠した ESD 保護機能を内蔵

2 アプリケーション

- 産業用センサ I/O
- PLC I/O モジュール
- アナログ入力
- 家電製品
- 医療用機器
- ビル・オートメーション

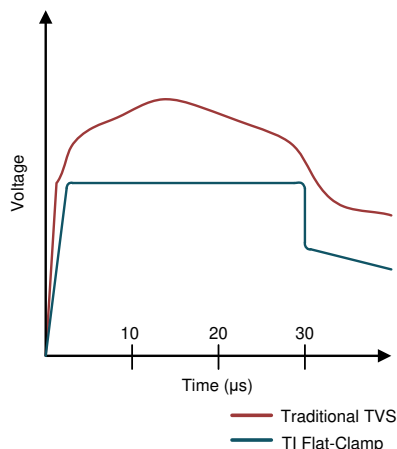

8/20μs のサージ・イベントに対する電圧クランプの応答

3 概要

TVS3301 デバイスは、最大 27A の IEC 61000-4-5 フォルト電流をシャントし、大電力の過渡現象や落雷からシステムを保護します。このデバイスは、一般的な産業用信号線の EMC 要件である、42Ω のインピーダンスで結合した 1kV の IEC 61000-4-5 開路電圧に耐えます。TVS3301 は帰還機構を使用して、フォルト中の正確なフラット・クランプを確保し、システムがさらされる電圧を、従来型の TVS ダイオードよりも低く保ちます。厳格な電圧レギュレーションにより、設計者は許容電圧が低いシステム部品でも安心して選択でき、堅牢性を損なうことなくシステムのコストと複雑性を低減できます。TVS3301 は ±33V の範囲で動作するため、逆配線に対する保護を必要とするシステムでも動作できます。

さらに、TVS3301 はスペースの制約が厳しいアプリケーション用に設計された小型の SON フットプリントで供給されるため、標準の SMA および SMB パッケージと比較して大幅なサイズ低減が可能です。リーク電流と容量が低いことから、保護するラインへの影響も最小限に抑えられます。製品のライフサイクル全体にわたる堅牢な保護を確保するため、テキサス・インスツルメンツは TVS3301 をテストし、125°C で 5000 回の反復サージに対してデバイス性能に変化がないことを確認しています。

パッケージ情報 (1) (2)

部品番号	パッケージ	本体サイズ (公称)
TVS3301	SON (DRB, 8)	3.00mm × 3.00mm

- 利用可能なパッケージについては、このデータシートの末尾にある注文情報を参照してください。
- 関連製品については、「デバイスの比較」の表を参照してください。

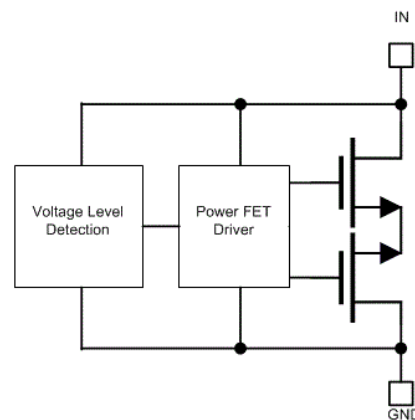

機能ブロック図



Table of Contents

1 特長.....	1	9.3 Feature Description.....	9
2 アプリケーション.....	1	9.4 Device Functional Modes.....	9
3 概要.....	1	10 Application and Implementation.....	11
4 Revision History.....	2	10.1 Application Information.....	11
5 概要 (続き).....	3	10.2 Typical Application.....	11
6 Device Comparison Table.....	3	11 Power Supply Recommendations.....	13
7 Pin Configuration and Functions.....	4	12 Layout.....	13
8 Specifications.....	5	12.1 Layout Guidelines.....	13
8.1 Absolute Maximum Ratings.....	5	12.2 Layout Example.....	13
8.2 ESD Ratings - JEDEC.....	5	13 Device and Documentation Support.....	14
8.3 ESD Ratings - IEC.....	5	13.1 Documentation Support.....	14
8.4 Recommended Operating Conditions.....	5	13.2 Receiving Notification of Documentation Updates..	14
8.5 Thermal Information.....	5	13.3 サポート・リソース.....	14
8.6 Electrical Characteristics.....	6	13.4 Trademarks.....	14
8.7 Typical Characteristics.....	7	13.5 Electrostatic Discharge Caution.....	14
9 Detailed Description.....	9	13.6 Glossary.....	14
9.1 Overview.....	9	14 Mechanical, Packaging, and Orderable Information.....	14
9.2 Functional Block Diagram.....	9		

4 Revision History

資料番号末尾の英字は改訂を表しています。その改訂履歴は英語版に準じています。

Changes from Revision A (December 2018) to Revision B (September 2022)	Page
• 文書全体の表、図、相互参照の採番方法を更新.....	1
• 「特長」セクションを更新し、機能安全対応の記述を追加.....	1

Changes from Revision * (September 2018) to Revision A (December 2018)	Page
• 「事前情報」から「量産データ」に変更.....	1

5 概要 (続き)

TVS3301 はテキサス・インスツルメンツのフラット・クランプ・サージ・デバイス・ファミリの製品です。フラット・クランプ・ファミリの詳細については、『[効率的なシステム保護のためのフラット・クランプ・サージ保護技術](#)』ホワイト・ペーパーを参照してください。

6 Device Comparison Table

DEVICE	V_{rwm}	V_{clamp} at I_{pp}	I_{pp} (8/20 μ s)	Leakage at V_{rwm}	POLARITY	Package
TVS0500	5	9.2 V	43 A	0.07 nA	Unidirectional	DRV (SON-6)
TVS0701	7	11 V	30 A	0.25 nA	Bidirectional	DRB (SON-8)
TVS1400	14	18.6 V	43 A	2 nA	Unidirectional	DRV (SON-6)
TVS1401	14	20.5 V	30 A	1.1 nA	Bidirectional	DRB (SON-8)
TVS1800	18	22.8 V	40 A	0.3 nA	Unidirectional	DRV (SON-6)
TVS1801	18	27.4 V	30 A	0.4 nA	Bidirectional	DRB (SON-8)
TVS2200	22	27.7 V	40 A	3.2 nA	Unidirectional	DRV (SON-6)
TVS2201	22	29.6 V	30 A	2 nA	Bidirectional	DRB (SON-8)
TVS2700	27	32.5 V	40 A	1.7 nA	Unidirectional	DRV (SON-6)
TVS2701	27	34 V	27 A	0.8 nA	Bidirectional	DRB (SON-8)
TVS3300	33	38 V	35 A	19 nA	Unidirectional	DRV (SON-6), YZF (WCSP)
TVS3301	33	40 V	27 A	2.5 nA	Bidirectional	DRB (SON-8)

7 Pin Configuration and Functions

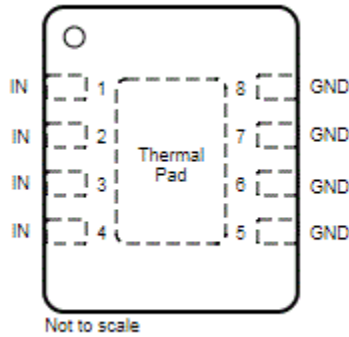

**图 7-1. DRB Package,
8-Pin SON
(Top View)**

表 7-1. Pin Functions

PIN		TYPE ⁽¹⁾	DESCRIPTION
NAME	DRB		
IN	1, 2, 3, 4	IN	Surge protected channel
GND	5, 6, 7, 8	GND	Ground
FLOAT	Exposed Thermal Pad	NC	Exposed thermal pad must be floating.

(1) IN = input, GND = ground, NC = no connection.

8 Specifications

8.1 Absolute Maximum Ratings

$T_A = 27^\circ\text{C}$ (unless otherwise noted)⁽¹⁾

		MIN	MAX	UNIT
Maximum Surge	IEC 61000-4-5 Current (8/20 μs)		± 27	A
	IEC 61000-4-5 Power (8/20 μs)		1100	W
	IEC 61643-321 Current (10/1000 μs)		± 3	A
	IEC 61643-321 Power (10/1000 μs)		120	W
EFT	IEC 61000-4-4 EFT Protection		± 80	A
I_{BR}	DC Current		20	mA
T_A	Ambient Operating Temperature	-40	125	$^\circ\text{C}$
T_{stg}	Storage Temperature	-65	150	$^\circ\text{C}$

- (1) Stresses beyond those listed under *Absolute Maximum Rating* may cause permanent damage to the device. These are stress ratings only, which do not imply functional operation of the device at these or any other conditions beyond those indicated under *Recommended Operating Condition*. Exposure to absolute-maximum-rated conditions for extended periods may affect device reliability.

8.2 ESD Ratings - JEDEC

			VALUE	UNIT
$V_{(ESD)}$	Electrostatic discharge	Human body model (HBM), per ANSI/ESDA/JEDEC JS-001, all pins ⁽¹⁾	± 2000	V
		Charged device model (CDM), per JEDEC specification JESD22-C101, all pins ⁽²⁾	± 500	

- (1) JEDEC document JEP155 states that 500-V HBM allows safe manufacturing with a standard ESD control process.
 (2) JEDEC document JEP157 states that 250-V CDM allows safe manufacturing with a standard ESD control process.

8.3 ESD Ratings - IEC

			VALUE	UNIT
$V_{(ESD)}$	Electrostatic discharge	IEC 61000-4-2 contact discharge	± 8	kV
		IEC 61000-4-2 air-gap discharge	± 15	

8.4 Recommended Operating Conditions

over operating free-air temperature range (unless otherwise noted)

		MIN	NOM	MAX	UNIT
V_{RWM}	Reverse Stand-Off Voltage		± 33		V

8.5 Thermal Information

THERMAL METRIC ⁽¹⁾		TVS3301	UNIT
		DRB (SON)	
		8 PINS	
R_{qJA}	Junction-to-ambient thermal resistance	52.0	$^\circ\text{C}/\text{W}$
$R_{qJC(top)}$	Junction-to-case (top) thermal resistance	56.1	$^\circ\text{C}/\text{W}$
R_{qJB}	Junction-to-board thermal resistance	24.9	$^\circ\text{C}/\text{W}$
Y_{JT}	Junction-to-top characterization parameter	2.1	$^\circ\text{C}/\text{W}$
Y_{JB}	Junction-to-board characterization parameter	24.8	$^\circ\text{C}/\text{W}$
$R_{qJC(bot)}$	Junction-to-case (bottom) thermal resistance	9.8	$^\circ\text{C}/\text{W}$

- (1) For more information about traditional and new thermal metrics, see the [Semiconductor and IC Package Thermal Metrics](#) application report.

8.6 Electrical Characteristics

over operating free-air temperature range (unless otherwise noted)

PARAMETER		TEST CONDITIONS	MIN	TYP	MAX	UNIT
I _{LEAK}	Leakage Current	Measured at V _{IN} = ±V _{RWM} , T _A = 27°C		2.5	110	nA
		Measured at V _{IN} = ±V _{RWM} , T _A = 85°C			450	
V _{BR}	Break-down Voltage	I _{IN} = ±1 mA	34.4	37.5		V
V _{CLAMP}	Clamp Voltage	±I _{pp} IEC 61000-4-5 Surge (8/20 μs), V _{IN} = 0 V before surge, T _A = 27°C		40	42.5	V
		21 A IEC 61000-4-5 Surge (8/20 μs), V _{IN} = ±V _{RWM} before surge, T _A = 125°C			43.2	
R _{DYN}	8/20 μs surge dynamic resistance	Calculated from V _{CLAMP} at .5*I _{PP} and I _{PP} surge current, T _A = 25°C		35		mΩ
C _{IN}	Input pin capacitance	V _{IN} = V _{RWM} , f = 1 MHz, 30 mV _{pp} , IO to GND		54		pF
SR	Maximum Slew Rate	0±V _{RWM} rising edge, sweep rise time and measure slew rate when I _{PEAK} = 1 mA, T _A = 27°C		2.5		V/μs
		0±V _{RWM} rising edge, sweep rise time and measure slew rate when I _{PEAK} = 1 mA, T _A = 85°C		1.0		

8.7 Typical Characteristics

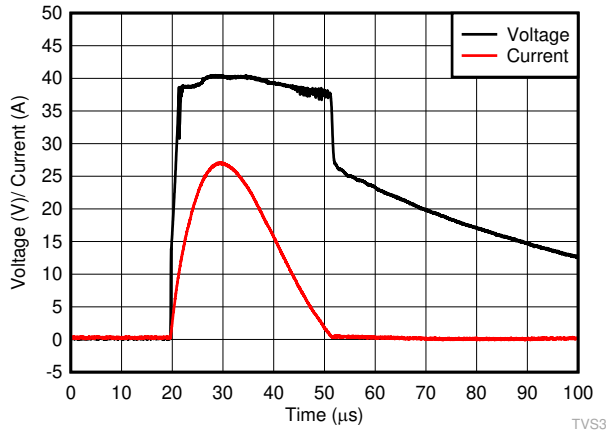

8-1. 8/20- μ s Surge Response at 27 A

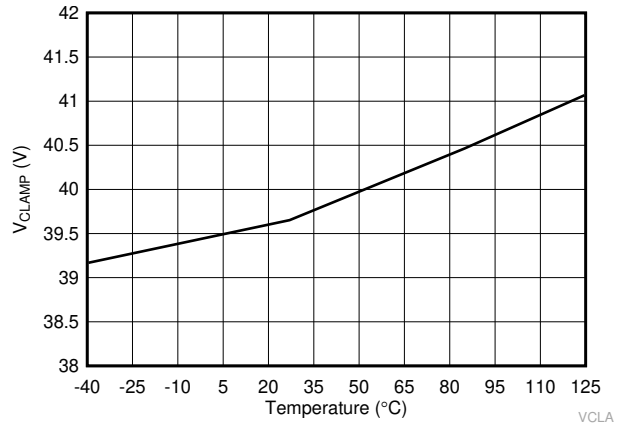

8-2. 8/20- μ s Surge Clamping Response at 21 A

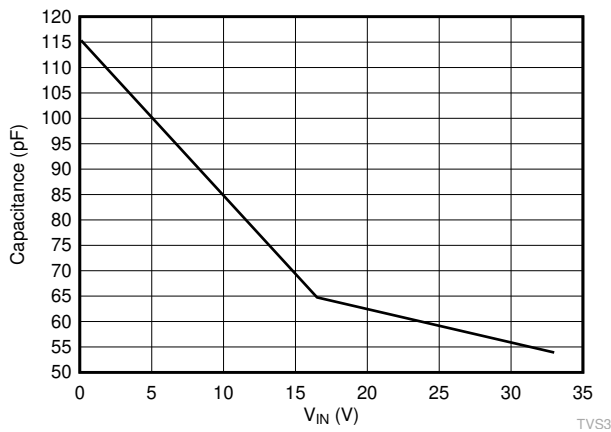

f = 1 MHz, 30 mVpp, IO to GND

8-3. Capacitance vs Voltage Bias

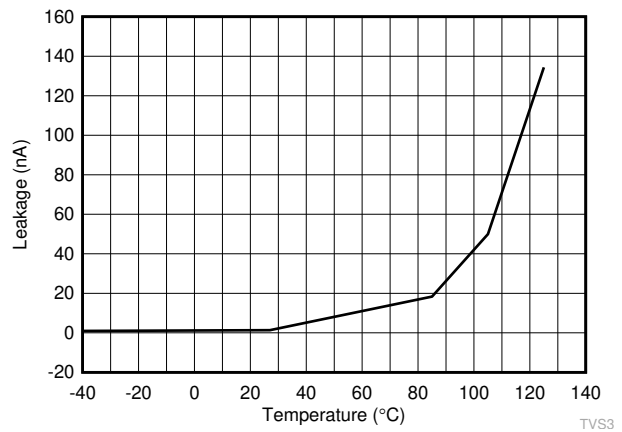

8-4. Leakage Current vs Temperature at 33 V

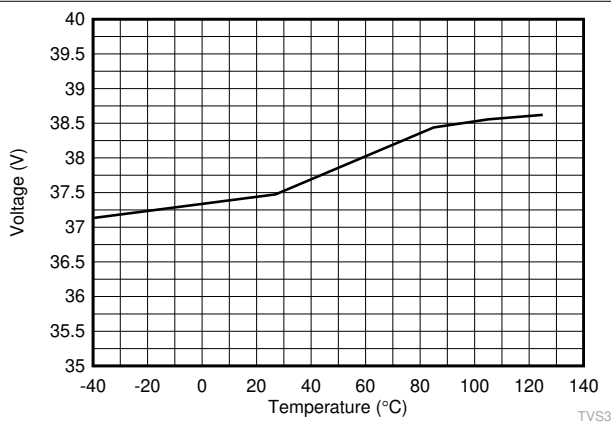

8-5. Breakdown Voltage (1 mA) vs Temperature

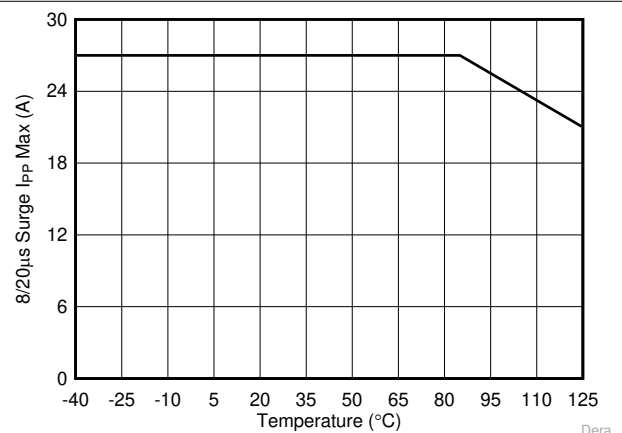

8-6. Maximum Surge Current (8/20 μ s) vs Temperature

8.7 Typical Characteristics (continued)

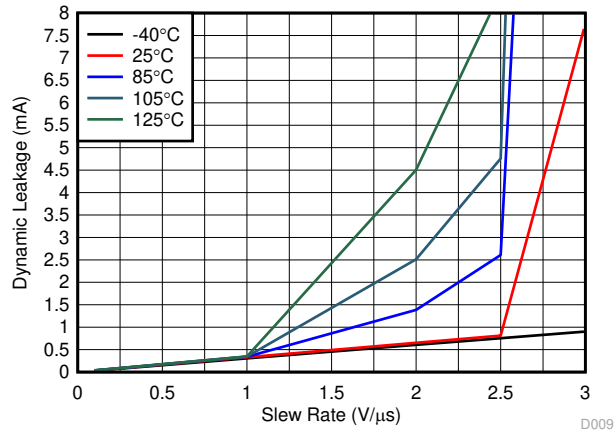

8-7. Dynamic Leakage vs Signal Slew Rate Across Temperature

9 Detailed Description

9.1 Overview

The TVS3301 is a bidirectional precision clamp with two integrated FETs driven by a feedback loop to tightly regulate the input voltage during an overvoltage event. This feedback loop leads to a very low dynamic resistance, giving a flat clamping voltage during transient overvoltage events like a surge.

9.2 Functional Block Diagram

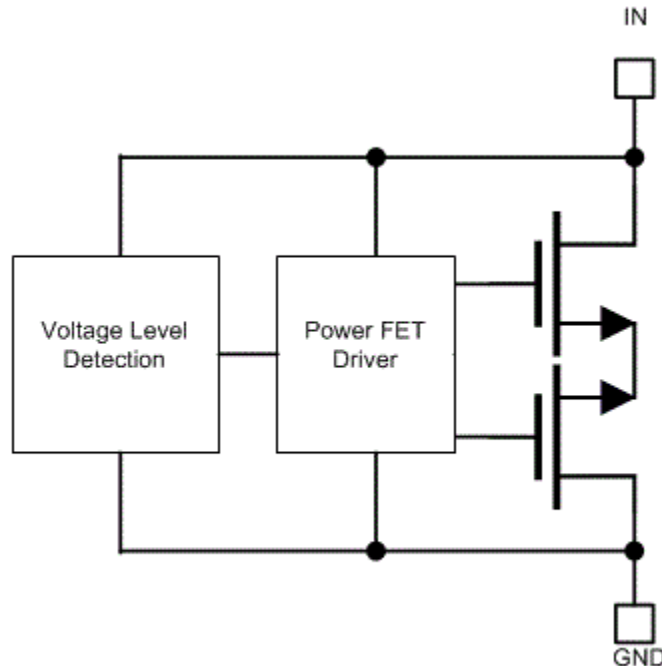

9.3 Feature Description

The TVS3301 is a precision clamp that handles 27 A of IEC 61000-4-5 8/20- μ s surge pulse. The flat clamping feature helps keep the clamping voltage very low to keep the downstream circuits from being stressed. The flat clamping feature can also help end-equipment designers save cost by opening up the possibility to use lower-cost, lower voltage tolerant downstream ICs. This device provides a bidirectional operating range, with a symmetrical V_{RWM} of ± 33 V designed for applications that have bipolar input signals or that must withstand reverse wiring conditions. The TVS3301 has minimal leakage at V_{RWM} , designed for applications where low leakage and power dissipation is a necessity. Built-in IEC 61000-4-2 and IEC 61000-4-4 ratings make it a robust protection solution for ESD and EFT events and the TVS3301 wide ambient temperature range of -40°C to $+125^{\circ}\text{C}$ enables usage in harsh industrial environments.

9.4 Device Functional Modes

9.4.1 Protection Specifications

The TVS3301 is specified according to both the IEC 61000-4-5 and IEC 61643-321 standards. This enables usage in systems regardless of which standard is required by relevant product standards or best matches measured fault conditions. The IEC 61000-4-5 standard requires protection against a pulse with a rise time of 8 μ s and a half-length of 20 μ s, while the IEC 61643-321 standard requires protection against a much longer pulse with a rise time of 10 μ s and a half-length of 1000 μ s.

The positive and negative surges are imposed to the TVS3301 by a combination wave generator (CWG) with a 2- Ω coupling resistor at different peak voltage levels. For powered-on transient tests that need power supply bias, inductances are used to decouple the transient stress and protect the power supply. The TVS3301 is post-tested by assuring that there is no shift in device breakdown or leakage at V_{RWM} .

In addition, the TVS3301 has been tested according to IEC 61000-4-5 to pass a ± 1 -kV surge test through a 42- Ω coupling resistor and a 0.5- μ F capacitor. This test is a common test requirement for industrial signal I/O lines and the TVS3301 precision clamp can be used in applications that have that requirement.

The TVS3301 integrates IEC 61000-4-2 level 4 ESD Protection and 80 A of IEC 61000-4-4 EFT Protection. These combine to ensure that the device can protect against most common transient test requirements.

For more information on TI's test methods for Surge, ESD, and EFT testing, refer to the [IEC 61000-4-x Tests for TI's Protection Devices](#) application report.

9.4.2 Reliability Testing

To ensure device reliability, the TVS3301 is characterized against 5000 repetitive pulses of 25-A IEC 61000-4-5 8/20- μ s surge pulses at 125°C. The test is performed with less than 10 seconds between each pulse at high temperature to simulate worst-case scenarios for fault regulation. After each surge pulse, the TVS3301 clamping voltage, breakdown voltage, and leakage are recorded to ensure that there is no variation or performance degradation. By ensuring robust, reliable, high temperature protection, the TVS3301 enables fault protection in applications that must withstand years of continuous operation with no performance change.

9.4.3 Minimal Derating

Unlike traditional diodes, the TVS3301 has very little derating of maximum power dissipation and ensures robust performance up to 125°C, shown in [Figure 8-6](#). Traditional TVS diodes lose up to 50% of their current carrying capability when at high temperatures, so a surge pulse above 85°C ambient can cause failures that are not seen at room temperature. The TVS3301 prevents this so the designer can see the surge protection regardless of temperature. Because of this, Flat-Clamp devices can provide robust protection against surge pulses that occur at high ambient temperatures, as shown in TI's [TVS Surge Protection in High-Temperature Environments](#) application report.

9.4.4 Bidirectional Operation

The TVS3301 is a bidirectional TVS with a symmetrical operating region. This allows for operation with positive and negative voltages, rather than just positive voltages like the unidirectional TVS3300. This allows for single chip protection for applications where the signal is expected to operate below 0 V or where there is a need to withstand a large common-mode voltage. In addition, there is a system requirement to be able to withstand reverse wiring conditions, in many cases where a high voltage signal is accidentally applied to the system ground and a ground is accidentally applied to the input terminal. This causes a large reverse voltage on the TVS diode that the device must be able to withstand. The TVS3301 is designed to not break down or see failures under reverse wiring conditions for applications that must withstand these miswiring issues.

注

If the applied signal is not expected to go below 0 V, a unidirectional device will clamp much lower in the reverse direction and should be used. In this case, the recommended device would be the TVS3300.

9.4.5 Transient Performance

During large transient swings, the TVS3301 will begin clamping the input signal to protect downstream conditions. While this prevents damage during fault conditions, it can cause leakage when the intended input signal has a fast slew rate. To keep power dissipation low and remove the chance of signal distortion, TI recommends that the designer keep the slew rate of any input signal on the TVS3301 below 2.5 V/ μ s at room temperature and below 1.0 V/ μ s at 85°C shown in [Figure 8-7](#). Faster slew rates will cause the device to clamp the input signal and draw current through the device for a few microseconds, increasing the rise time of the signal. This will not cause any harm to the system or to the device, however, it can cause device overheating if the fast input voltage swings occur regularly.

10 Application and Implementation

注

以下のアプリケーション情報は、TI の製品仕様に含まれるものではなく、TI ではその正確性または完全性を保証いたしません。個々の目的に対する製品の適合性については、お客様の責任で判断していただくことになります。お客様は自身の設計実装を検証しテストすることで、システムの機能を確認する必要があります。

10.1 Application Information

The TVS3301 can be used to protect any power, analog, or digital signal from transient fault conditions caused by the environment or other electrical components. One common example is using the TVS3301 to protect both sides of a PLC module and a sensor transmitter, as shown in the following figure. The transmitter side of this will be examined in more detail in the following section.



図 10-1. TVS3301 Application Example

10.2 Typical Application

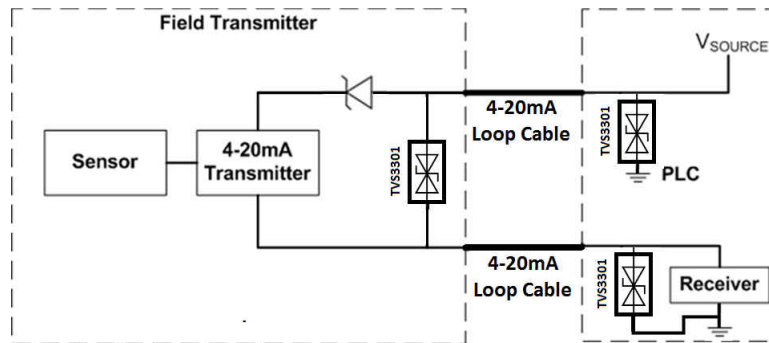

図 10-2. TVS3301 Application Schematic

10.2.1 Design Requirements

A typical operation for the TVS3301 would be protecting an analog output module on a PLC similar to [Figure 10-2](#). In this example, the TVS3301 is protecting a 4-20 mA transmitter that uses the XTR115, a standard transmitter that has a nominal voltage of 24 V and a maximum input voltage of 40 V. Most industrial interfaces such as this require protection against ± 1 kV surge test through a 42- Ω coupling resistor and a 0.5- μ F capacitor, equaling roughly 24 A of surge current. The system also requires protection from reverse wiring conditions. Without any input protection, this input voltage will rise to hundreds of volts for multiple microseconds, and violate the absolute maximum input voltage and harm the device if a surge event is caused by lightning, coupling, ringing, or any other fault condition. TI's Flat-Clamp technology provides surge protection diodes that can maximize the useable voltage range and clamp at a safe level for the system.

10.2.2 Detailed Design Procedure

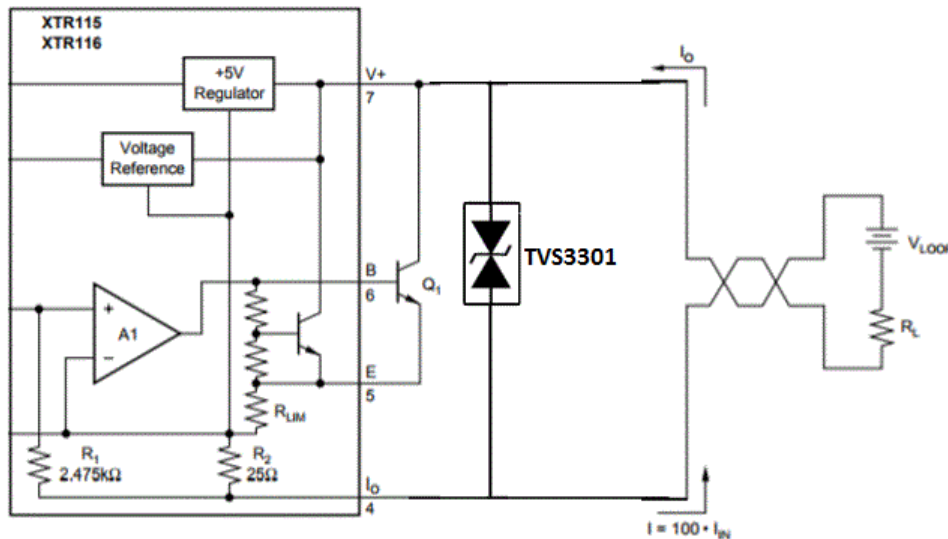
If the TVS3301 is in place to protect the device, the voltage will rise to the breakdown of the diode at 37.5 V, during a surge event. The TVS3301 will then turn on to shunt the surge current to ground. With the low dynamic resistance of the TVS3301, large amounts of surge current will have minimal impact on the clamping voltage. The dynamic resistance of the TVS3301 is around 35 m Ω , which means a 24-A surge current will cause a voltage raise of $24 \text{ A} \times 35 \text{ m}\Omega = 0.84 \text{ V}$. Because the device turns on at 37.5 V, this means the XTR115 input will be exposed to a maximum of $37.5 \text{ V} + 0.84 \text{ V} = 38.34 \text{ V}$ during surge pulses, well within the absolute maximum input voltage to ensure robust protection of the circuit.

Because the TVS3301 is a bidirectional device, it also satisfies the condition for withstanding reverse wiring. In this case, if V_{LOOP} is wired in reverse, the input terminal of the TVS3301 will see -24 V , which is below the negative V_{RWM} . The leakages will be the same as if the battery is wired properly.

The small size of the device also improves fault protection by lowering the effect of fault current coupling onto neighboring traces. The small form factor of the TVS3301 allows the device to be placed extremely close to the input connector, which lowers the length of the path fault current going through the system compared to larger protection solutions. Finally, the low leakage of the TVS3301 will have low input power losses. At 33 V, the device will see typical 2.5-nA leakage for a constant power dissipation of less than 100 μ W, a small quantity that will minimally effect overall efficiency metrics and heating concerns.

10.2.3 Application Curves

As shown in [Figure 10-3](#), the TVS3301 will clamp when exposed to a surge.

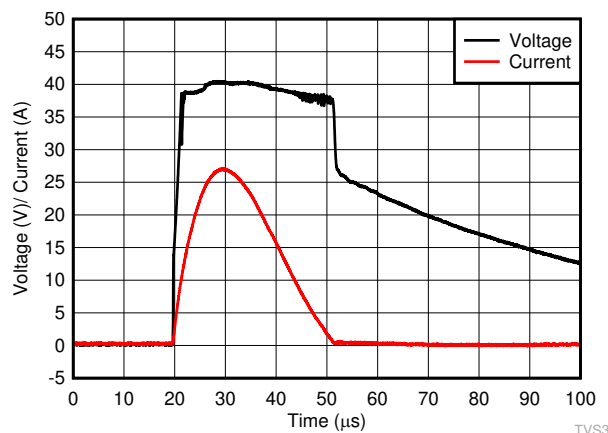

Figure 10-3. TVS3301 Clamping Waveform (27-A, 8/20- μ s Surge)

10.2.4 PLC Surge Protection Reference Design

For a detailed description of the Flat-Clamp devices advantages in a PLC Analog Input Module, reference TI's [Surge Protection Reference Design for PLC Analog Input Module](#). This document describes the considerations and performance of the TVS3300 in a common industrial application. While the document does not reference the TVS3301 specifically, performance between the devices should be similar.

11 Power Supply Recommendations

The TVS3301 is a clamping device so there is no need to power it. To ensure the device functions properly do not violate the recommended V_{IN} voltage range (–33 V to 33 V).

12 Layout

12.1 Layout Guidelines

The optimum placement is close to the connector. EMI during an ESD event can couple from the tested trace to other nearby unprotected traces, which could result in system failures. The PCB designer must minimize the possibility of EMI coupling by keeping all unprotected traces away from protected traces between the TVS and the connector. Route the protected traces straight. Use rounded corners with the largest radii possible to eliminate any sharp corners on the protected traces between the TVS3301 and the connector. Electric fields tend to build up on corners, which could increase EMI coupling.

Ensure that the thermal pad on the layout is floating rather than grounded. Grounding the thermal pad will impede the operating range of the TVS3301, and can cause failures when the applied voltage is negative. A floating thermal pad allows the maximum operating range without sacrificing any transient performance.

12.2 Layout Example

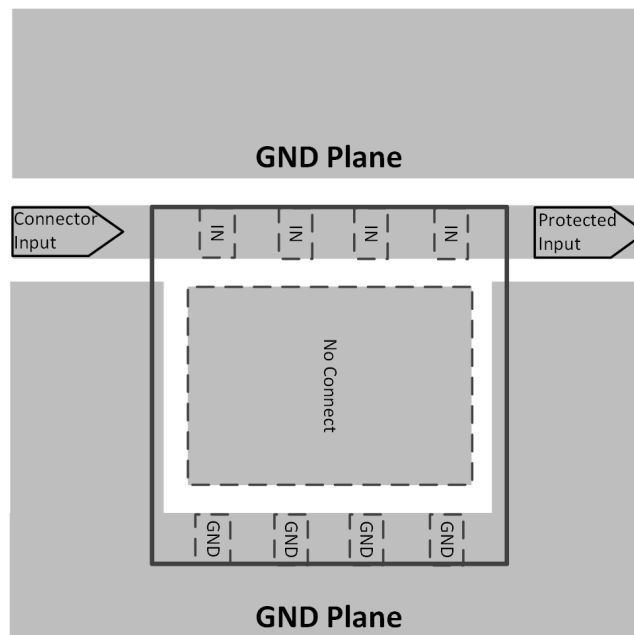

12-1. TVS3301 Layout

13 Device and Documentation Support

13.1 Documentation Support

13.1.1 Related Documentation

For related documentation, see the following:

- Texas Instruments, [Flat-Clamp Surge Protection Technology for Efficient System Protection white papers](#)
- Texas Instruments, [IEC 61000-4-x Tests for TI's Protection Devices application reports](#)
- Texas Instruments, [Surge Protection Reference Design for PLC Analog Input Module](#)
- Texas Instruments, [TVS Surge Protection in High-Temperature Environments application reports](#)
- Texas Instruments, [TVS3301 Functional Safety, FIT Rate, Failure Mode Distribution and Pin FMA](#)

13.2 Receiving Notification of Documentation Updates

To receive notification of documentation updates, navigate to the device product folder on [ti.com](#). Click on [Subscribe to updates](#) to register and receive a weekly digest of any product information that has changed. For change details, review the revision history included in any revised document.

13.3 サポート・リソース

TI E2E™ サポート・フォーラムは、エンジニアが検証済みの回答と設計に関するヒントをエキスパートから迅速かつ直接得ることができる場所です。既存の回答を検索したり、独自の質問をしたりすることで、設計に必要な支援を迅速に得ることができます。

リンクされているコンテンツは、該当する貢献者により、現状のまま提供されるものです。これらは TI の仕様を構成するものではなく、必ずしも TI の見解を反映したものではありません。TI の [使用条件](#) を参照してください。

13.4 Trademarks

TI E2E™ is a trademark of Texas Instruments.

すべての商標は、それぞれの所有者に帰属します。

13.5 Electrostatic Discharge Caution



This integrated circuit can be damaged by ESD. Texas Instruments recommends that all integrated circuits be handled with appropriate precautions. Failure to observe proper handling and installation procedures can cause damage.

ESD damage can range from subtle performance degradation to complete device failure. Precision integrated circuits may be more susceptible to damage because very small parametric changes could cause the device not to meet its published specifications.

13.6 Glossary

[TI Glossary](#) This glossary lists and explains terms, acronyms, and definitions.

14 Mechanical, Packaging, and Orderable Information

The following pages include mechanical, packaging, and orderable information. This information is the most current data available for the designated devices. This data is subject to change without notice and revision of this document. For browser-based versions of this data sheet, refer to the left-hand navigation.

PACKAGING INFORMATION

Orderable part number	Status (1)	Material type (2)	Package Pins	Package qty Carrier	RoHS (3)	Lead finish/ Ball material (4)	MSL rating/ Peak reflow (5)	Op temp (°C)	Part marking (6)
TVS3301DRBR	Active	Production	SON (DRB) 8	3000 LARGE T&R	Yes	NIPDAU	Level-2-260C-1 YEAR	-40 to 125	1PQP
TVS3301DRBR.A	Active	Production	SON (DRB) 8	3000 LARGE T&R	Yes	NIPDAU	Level-2-260C-1 YEAR	-40 to 125	1PQP

(1) **Status:** For more details on status, see our [product life cycle](#).

(2) **Material type:** When designated, preproduction parts are prototypes/experimental devices, and are not yet approved or released for full production. Testing and final process, including without limitation quality assurance, reliability performance testing, and/or process qualification, may not yet be complete, and this item is subject to further changes or possible discontinuation. If available for ordering, purchases will be subject to an additional waiver at checkout, and are intended for early internal evaluation purposes only. These items are sold without warranties of any kind.

(3) **RoHS values:** Yes, No, RoHS Exempt. See the [TI RoHS Statement](#) for additional information and value definition.

(4) **Lead finish/Ball material:** Parts may have multiple material finish options. Finish options are separated by a vertical ruled line. Lead finish/Ball material values may wrap to two lines if the finish value exceeds the maximum column width.

(5) **MSL rating/Peak reflow:** The moisture sensitivity level ratings and peak solder (reflow) temperatures. In the event that a part has multiple moisture sensitivity ratings, only the lowest level per JEDEC standards is shown. Refer to the shipping label for the actual reflow temperature that will be used to mount the part to the printed circuit board.

(6) **Part marking:** There may be an additional marking, which relates to the logo, the lot trace code information, or the environmental category of the part.

Multiple part markings will be inside parentheses. Only one part marking contained in parentheses and separated by a "~" will appear on a part. If a line is indented then it is a continuation of the previous line and the two combined represent the entire part marking for that device.

Important Information and Disclaimer:The information provided on this page represents TI's knowledge and belief as of the date that it is provided. TI bases its knowledge and belief on information provided by third parties, and makes no representation or warranty as to the accuracy of such information. Efforts are underway to better integrate information from third parties. TI has taken and continues to take reasonable steps to provide representative and accurate information but may not have conducted destructive testing or chemical analysis on incoming materials and chemicals. TI and TI suppliers consider certain information to be proprietary, and thus CAS numbers and other limited information may not be available for release.

In no event shall TI's liability arising out of such information exceed the total purchase price of the TI part(s) at issue in this document sold by TI to Customer on an annual basis.

TAPE AND REEL INFORMATION

QUADRANT ASSIGNMENTS FOR PIN 1 ORIENTATION IN TAPE

*All dimensions are nominal

Device	Package Type	Package Drawing	Pins	SPQ	Reel Diameter (mm)	Reel Width W1 (mm)	A0 (mm)	B0 (mm)	K0 (mm)	P1 (mm)	W (mm)	Pin1 Quadrant
TVS3301DRBR	SON	DRB	8	3000	330.0	12.4	3.3	3.3	1.1	8.0	12.0	Q2

TAPE AND REEL BOX DIMENSIONS

*All dimensions are nominal

Device	Package Type	Package Drawing	Pins	SPQ	Length (mm)	Width (mm)	Height (mm)
TVS3301DRBR	SON	DRB	8	3000	338.0	355.0	50.0

DRB 8

GENERIC PACKAGE VIEW

VSON - 1 mm max height

PLASTIC SMALL OUTLINE - NO LEAD



Images above are just a representation of the package family, actual package may vary.
Refer to the product data sheet for package details.

4203482/L

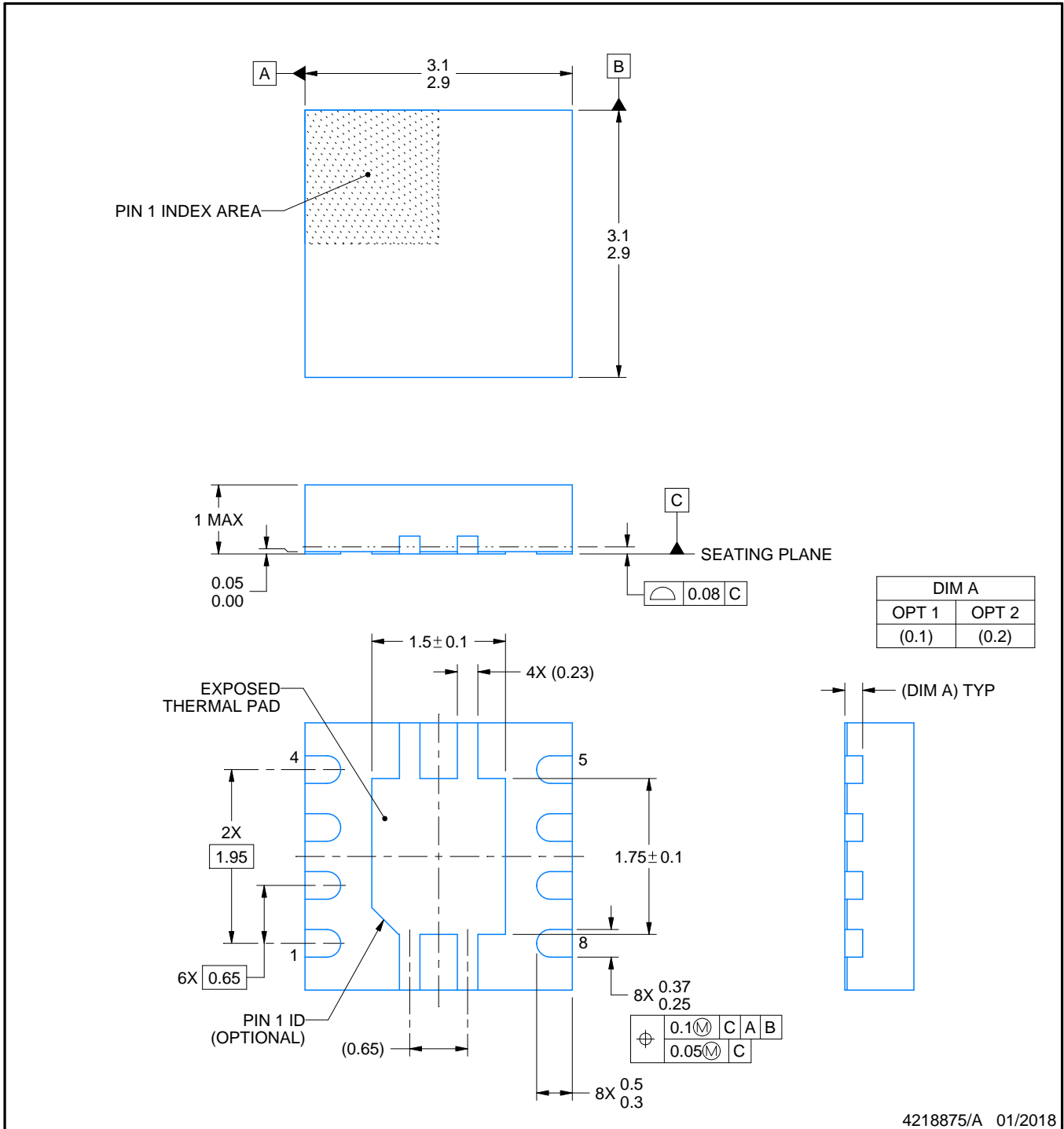

4218875/A 01/2018

NOTES:

1. All linear dimensions are in millimeters. Any dimensions in parenthesis are for reference only. Dimensioning and tolerancing per ASME Y14.5M.
2. This drawing is subject to change without notice.
3. The package thermal pad must be soldered to the printed circuit board for thermal and mechanical performance.

EXAMPLE BOARD LAYOUT

DRB0008A

VSON - 1 mm max height

PLASTIC SMALL OUTLINE - NO LEAD

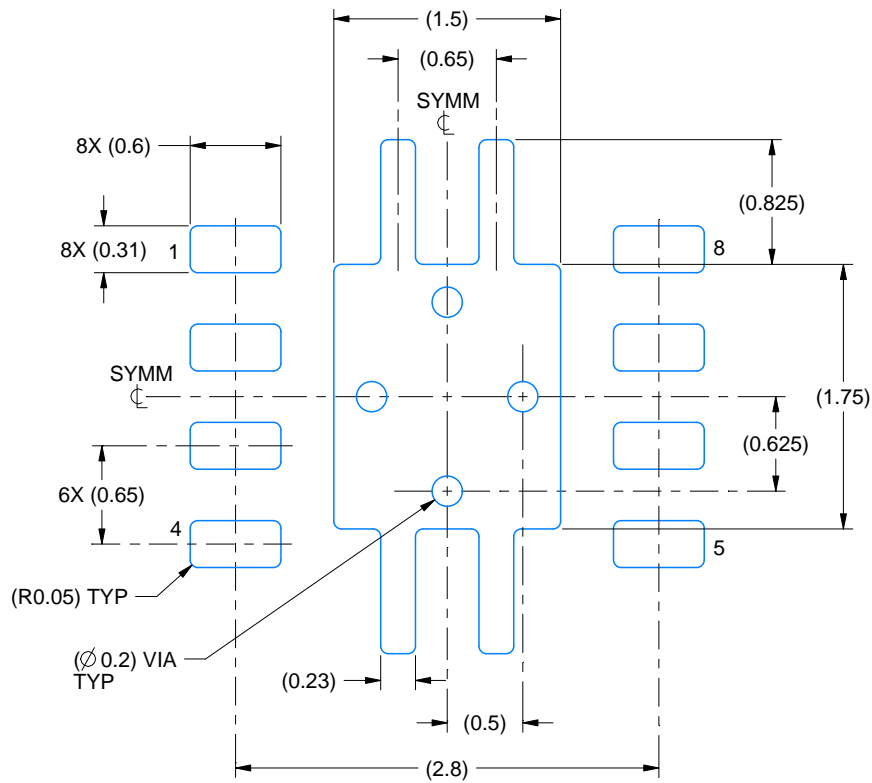

LAND PATTERN EXAMPLE
EXPOSED METAL SHOWN
SCALE:20X

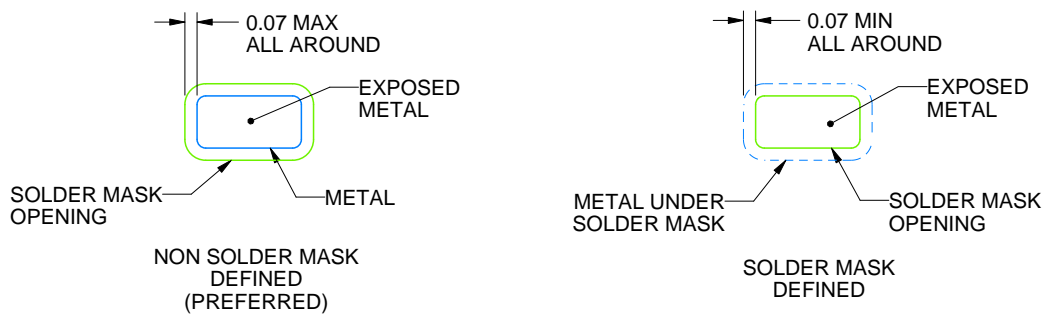

SOLDER MASK DETAILS

4218875/A 01/2018

NOTES: (continued)

4. This package is designed to be soldered to a thermal pad on the board. For more information, see Texas Instruments literature number SLUA271 (www.ti.com/lit/sluea271).
5. Vias are optional depending on application, refer to device data sheet. If any vias are implemented, refer to their locations shown on this view. It is recommended that vias under paste be filled, plugged or tented.

EXAMPLE STENCIL DESIGN

DRB0008A

VSON - 1 mm max height

PLASTIC SMALL OUTLINE - NO LEAD

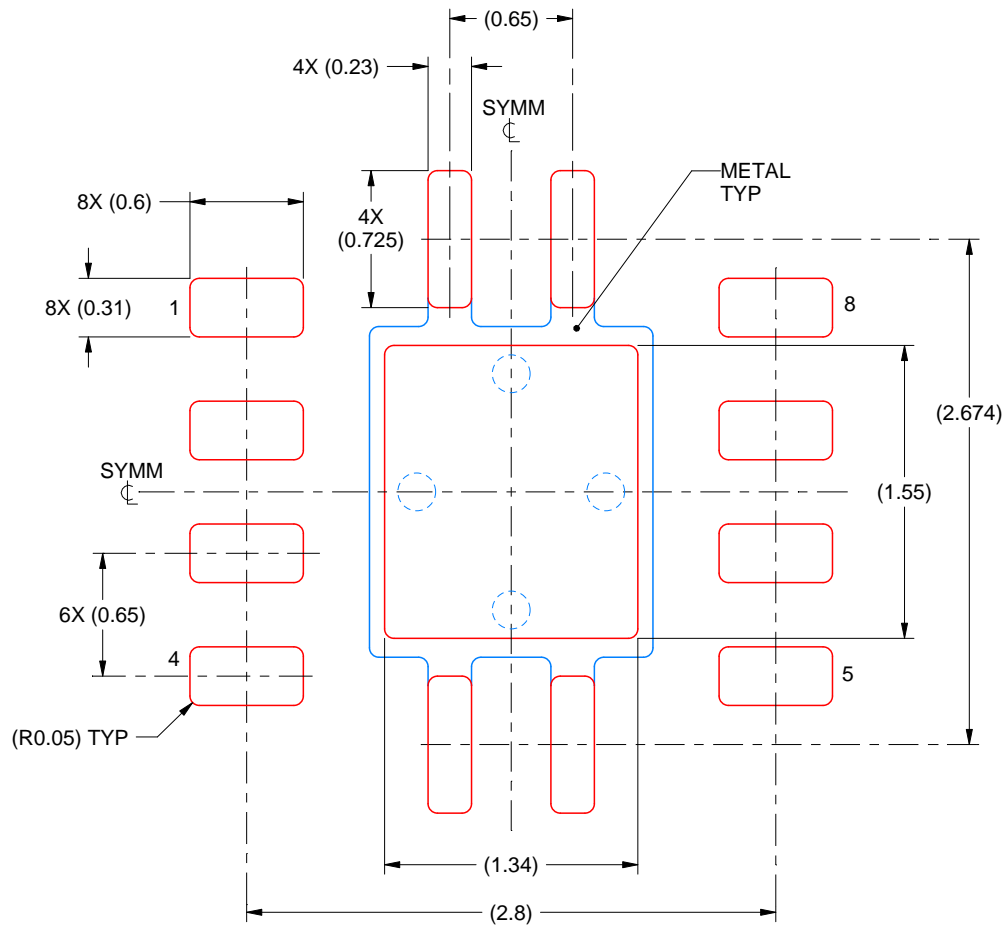

SOLDER PASTE EXAMPLE
BASED ON 0.125 mm THICK STENCIL

EXPOSED PAD
84% PRINTED SOLDER COVERAGE BY AREA
SCALE:25X

4218875/A 01/2018

NOTES: (continued)

6. Laser cutting apertures with trapezoidal walls and rounded corners may offer better paste release. IPC-7525 may have alternate design recommendations.

重要なお知らせと免責事項

TI は、技術データと信頼性データ(データシートを含みます)、設計リソース(リファレンス デザインを含みます)、アプリケーションや設計に関する各種アドバイス、Web ツール、安全性情報、その他のリソースを、欠陥が存在する可能性のある「現状のまま」提供しており、商品性および特定目的に対する適合性の黙示保証、第三者の知的財産権の非侵害保証を含むいかなる保証も、明示的または黙示的にかかわらず拒否します。

これらのリソースは、TI 製品を使用する設計の経験を積んだ開発者への提供を意図したものです。(1) お客様のアプリケーションに適した TI 製品の選定、(2) お客様のアプリケーションの設計、検証、試験、(3) お客様のアプリケーションに該当する各種規格や、その他のあらゆる安全性、セキュリティ、規制、または他の要件への確実な適合に関する責任を、お客様のみが単独で負うものとし、

上記の各種リソースは、予告なく変更される可能性があります。これらのリソースは、リソースで説明されている TI 製品を使用するアプリケーションの開発の目的でのみ、TI はその使用をお客様に許諾します。これらのリソースに関して、他の目的で複製することや掲載することは禁止されています。TI や第三者の知的財産権のライセンスが付与されている訳ではありません。お客様は、これらのリソースを自身で使用した結果発生するあらゆる申し立て、損害、費用、損失、責任について、TI およびその代理人を完全に補償するものとし、TI は一切の責任を拒否します。

TI の製品は、[TI の販売条件](#)、[TI の総合的な品質ガイドライン](#)、[ti.com](#) または TI 製品などに関連して提供される他の適用条件に従い提供されます。TI がこれらのリソースを提供することは、適用される TI の保証または他の保証の放棄の拡大や変更を意味するものではありません。TI がカスタム、またはカスタマー仕様として明示的に指定していない限り、TI の製品は標準的なカタログに掲載される汎用機器です。

お客様がいかなる追加条項または代替条項を提案する場合も、TI はそれらに異議を唱え、拒否します。

Copyright © 2025, Texas Instruments Incorporated

最終更新日：2025 年 10 月