

# CD4026B, CD4033B Types

## CMOS Decade Counters/Dividers

High-Voltage Types (20-Volt Rating)

With Decoded 7-Segment Display Outputs and:

Display Enable - CD4026B

Ripple Blanking - CD4033B

■ CD4026B and CD4033B each consist of a 5-stage Johnson decade counter and an output decoder which converts the Johnson code to a 7-segment decoded output for driving one stage in a numerical display.

These devices are particularly advantageous in display applications where low power dissipation and/or low package count are important.

Inputs common to both types are CLOCK, RESET, & CLOCK INHIBIT; common outputs are CARRY OUT and the seven decoded outputs (a, b, c, d, e, f, g). Additional inputs and outputs for the CD4026B include DISPLAY ENABLE input and DISPLAY ENABLE and UNGATED "C-SEGMENT" outputs. Signals peculiar to the CD4033B are RIPPLE-BLANKING INPUT AND LAMP TEST INPUT and a RIPPLE-BLANKING OUTPUT.

A high RESET signal clears the decade counter to its zero count. The counter is advanced one count at the positive clock signal transition if the CLOCK INHIBIT signal is low. Counter advancement via the clock line is inhibited when the CLOCK INHIBIT signal is high. The CLOCK INHIBIT signal can be used as a negative-edge clock if the clock line is held high. Antilock gating is provided on the JOHNSON counter, thus assuring proper counting sequence. The CARRY-OUT ( $C_{out}$ ) signal completes one cycle every ten CLOCK INPUT cycles and is used to clock the succeeding decade directly in a multi-decade counting chain. The seven decoded outputs (a, b, c, d, e, f, g) illuminate the proper segments in a seven

### MAXIMUM RATINGS, Absolute-Maximum Values:

#### DC SUPPLY-VOLTAGE RANGE, ( $V_{DD}$ )

Voltages referenced to  $V_{SS}$  Terminal ..... -0.5V to +20V

INPUT VOLTAGE RANGE, ALL INPUTS ..... -0.5V to  $V_{DD} + 0.5V$

DC INPUT CURRENT, ANY ONE INPUT .....  $\pm 10mA$

#### POWER DISSIPATION PER PACKAGE ( $P_D$ ):

For  $T_A = -55^\circ C$  to  $+100^\circ C$  ..... 500mW

For  $T_A = +100^\circ C$  to  $+125^\circ C$  ..... Derate Linearly at 12mW/ $^\circ C$  to 200mW

#### DEVICE DISSIPATION PER OUTPUT TRANSISTOR

FOR  $T_A =$  FULL PACKAGE-TEMPERATURE RANGE (All Package Types) ..... 100mW

OPERATING-TEMPERATURE RANGE ( $T_A$ ) .....  $-55^\circ C$  to  $+125^\circ C$

STORAGE TEMPERATURE RANGE ( $T_{stg}$ ) .....  $-65^\circ C$  to  $+150^\circ C$

#### LEAD TEMPERATURE (DURING SOLDERING):

At distance 1/16  $\pm$  1/32 inch (1.59  $\pm$  0.79mm) from case for 10s max .....  $+265^\circ C$

### Features:

- Counter and 7-segment decoding in one package
- Easily interfaced with 7-segment display types
- Fully static counter operation: DC to 6 MHz (typ.) at  $V_{DD}=10V$
- Ideal for low-power displays
- Display enable output (CD4026B)
- "Ripple blanking" and lamp test (CD4033B)
- 100% tested for quiescent current at 20 V
- Standardized, symmetrical output characteristics
- 5-V, 10-V, and 15-V parametric ratings
- Schmitt-triggered clock inputs
- Meets all requirements of JEDEC Tentative Standard No. 13B, "Standard Specifications for Description of 'B' Series CMOS Devices"

### Applications

- Decade counting 7-segment decimal display
- Frequency division 7-segment decimal displays
- Clocks, watches, timers (e.g.  $\div 60$ ,  $\div 60$ ,  $\div 12$  counter/display)
- Counter/display driver for meter applications

segment display device used for representing the decimal numbers 0 to 9. The 7-segment outputs go high on selection in the CD4033B; in the CD4026B these outputs go high only when the DISPLAY ENABLE IN is high.

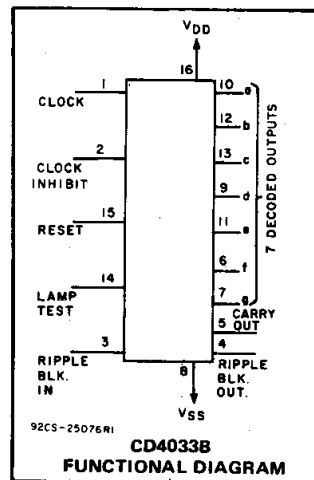
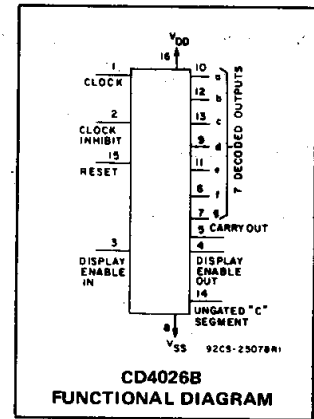

### TERMINAL DIAGRAMS

#### Top View

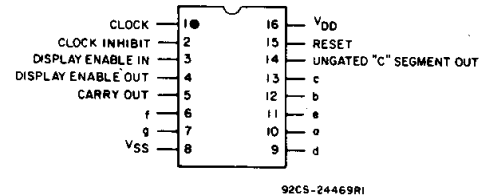

CD4026B

#### Top View

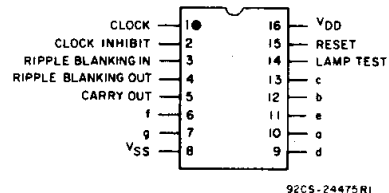

CD4033B

## CD4026B, CD4033B Types

### RECOMMENDED OPERATING CONDITIONS

For maximum reliability, nominal operating conditions should be selected so that operation is always within the following ranges:

CHARACTERISTIC	VDD (V)	LIMITS		UNITS
		MIN.	MAX.	
Supply-Voltage Range (For T <sub>A</sub> = Full Package Temperature Range)		3	18	V
Clock Input Frequency, f <sub>CL</sub>	5	—	2.5	MHz
	10	—	5.5	
	15	—	8	
Clock Pulse Width, t <sub>WCL</sub>	5	220	—	ns
	10	100	—	
	15	80	—	
Clock Rise and Fall Time, t <sub>rCL</sub> , t <sub>fCL</sub>	5	—	Unlimited	ns
	10	—		
	15	—		
Clock Inhibit Set Up Time, t <sub>SU</sub>	5	200	—	ns
	10	50	—	
	15	30	—	
Reset Pulse Width, t <sub>W</sub>	5	200	—	ns
	10	100	—	
	15	50	—	
Reset Removal Time	5	30	—	ns
	10	15	—	
	15	10	—	

### CD4026B

When the DISPLAY ENABLE IN is low the seven decoded outputs are forced low regardless of the state of the counter. Activation of the display only when required results in significant power savings. This system also facilitates implementation of display-character multiplexing.

The CARRY OUT and UNGATED "C-SEGMENT" signals are not gated by the DISPLAY ENABLE and therefore are available continuously. This feature is a requirement in implementation of certain divider functions such as divide-by-60 and divide-by-12.

### CD4033B

The CD4033B has provisions for automatic blanking of the non-significant zeros in a multi-digit decimal number which results in an easily readable display consistent with normal writing practice. For example, the number 0050.0700 in an eight digit display would be displayed as 50.07. Zero suppression on the integer side is obtained by connecting the RBI terminal of the CD4033B associated with the most significant digit in the display to a low-level voltage and connecting the RBO terminal of that stage to the RBI terminal of the CD4033B in the next-lower significant position in the display. This procedure is continued for each succeeding CD4033B on the integer side of the display.

On the fraction side of the display the RBI of the CD4033B associated with the least significant bit is connected to a low-level voltage and the RBO of that CD4033B is connected to the RBI terminal of the CD4033B in the next more-significant-bit position. Again, this procedure is continued for all CD4033B's on the fraction side of the display.

In a purely fractional number the zero immediately preceding the decimal point can be displayed by connecting the RBI of that stage to a high level voltage (instead of to the RBO of the next more-significant-stage). For example: optional zero → 0.7346. Likewise, the zero in a number such as 763.0 can be displayed by connecting the RBI of the CD4033B associated with it to a high-level voltage.

Ripple blanking of non-significant zeros provides an appreciable savings in display power.

The CD4033B has a LAMP TEST input which, when connected to a high-level voltage, overrides normal decoder operation and enables a check to be made on possible display malfunctions by putting the seven outputs in the high state.

The CD4026B- and CD4033B-series types are supplied in 16-lead dual-in-line plastic packages (E suffix), 16-lead small-outline packages (NSR suffix), and 16-lead thin shrink small-outline packages (PW and PWR suffixes).

### STATIC ELECTRICAL CHARACTERISTICS

CHARACTERISTIC	CONDITIONS			LIMITS AT INDICATED TEMPERATURES (°C)							UNITS
	V <sub>O</sub> (V)	V <sub>IN</sub> (V)	V <sub>DD</sub> (V)	-55	-40	+85	+125	+25			
								Min.	Typ.	Max.	
Quiescent Device Current, I <sub>DD</sub> Max.	—	0,5	5	5	5	150	150	—	0.04	5	μA
	—	0,10	10	10	10	300	300	—	0.04	10	
	—	0,15	15	20	20	600	600	—	0.04	20	
	—	0,20	20	100	100	3000	3000	—	0.08	100	
Output Low (Sink) Current I <sub>OL</sub> Min.	0.4	0,5	5	0.64	0.61	0.42	0.36	0.51	1	—	mA
	0.5	0,10	10	1.6	1.5	1.1	0.9	1.3	2.6	—	
	1.5	0,15	15	4.2	4	2.8	2.4	3.4	6.8	—	
Output High (Source) Current, I <sub>OH</sub> Min.	4.6	0,5	5	-0.64	-0.61	-0.42	-0.36	-0.51	-1	—	mA
	2.5	0,5	5	-2	-1.8	-1.3	-1.15	-1.6	-3.2	—	
	9.5	0,10	10	-1.6	-1.5	-1.1	-0.9	-1.3	-2.6	—	
	13.5	0,15	15	-4.2	-4	-2.8	-2.4	-3.4	-6.8	—	
Output Voltage: Low-Level, V <sub>OL</sub> Max.	—	0,5	5	0.05				—	0	0.05	V
	—	0,10	10	0.05				—	0	0.05	
	—	0,15	15	0.05				—	0	0.05	
Output Voltage: High-Level, V <sub>OH</sub> Min.	—	0,5	5	4.95				4.95	5	—	V
	—	0,10	10	9.95				9.95	10	—	
	—	0,15	15	14.95				14.95	15	—	
Input Low Voltage, V <sub>IL</sub> Max.	0.5, 4.5	—	5	1.5				—	—	1.5	V
	1, 9	—	10	3				—	—	3	
	1.5, 13.5	—	15	4				—	—	4	
Input High Voltage, V <sub>IH</sub> Min.	0.5, 4.5	—	5	3.5				3.5	—	—	V
	1, 9	—	10	7				7	—	—	
	1.5, 13.5	—	15	11				11	—	—	
Input Current I <sub>IN</sub> Max.	—	0,18	18	±0.1	±0.1	±1	±1	—	±10 <sup>-5</sup>	±0.1	μA

# CD4026B, CD4033B Types

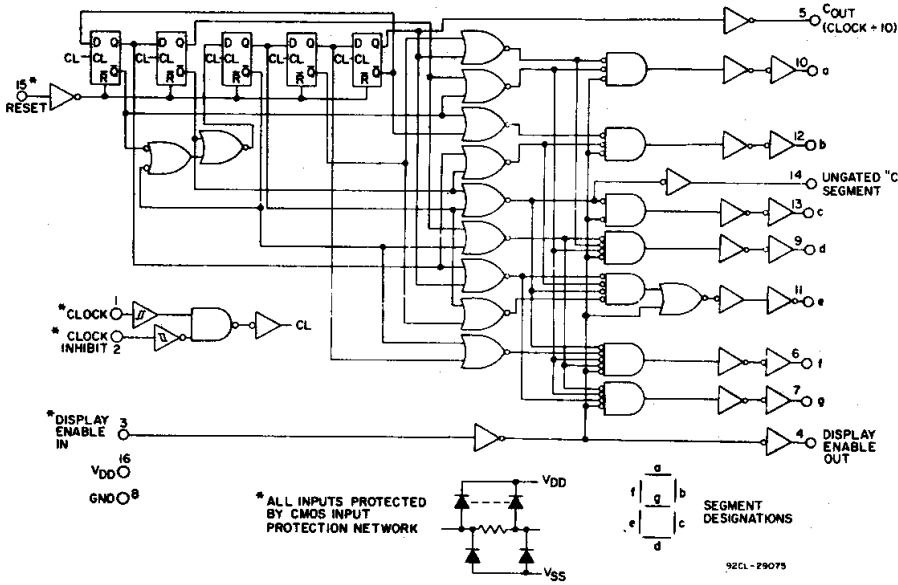

Fig. 1 - CD4026B logic diagram.

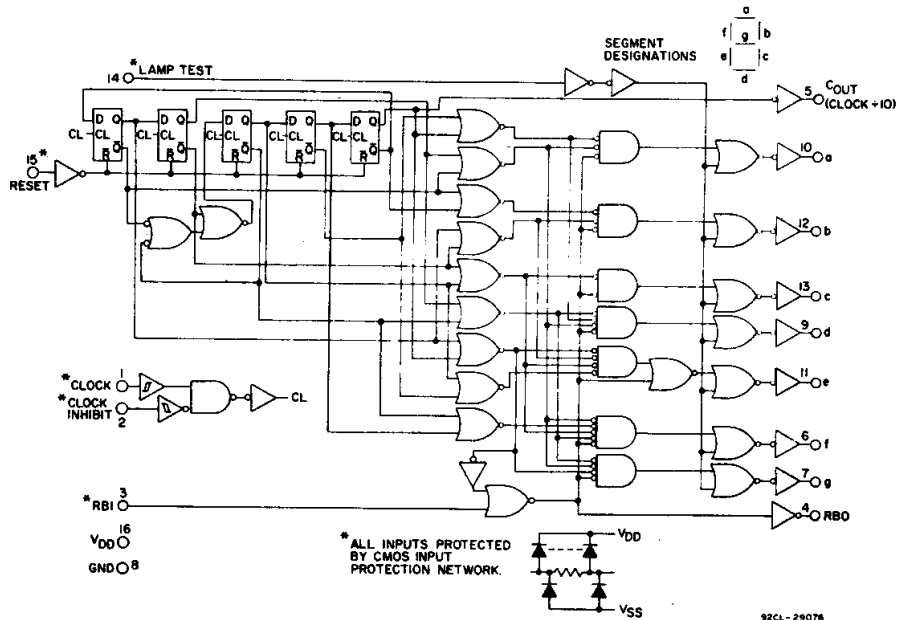

Fig. 2 - CD4033B logic diagram.

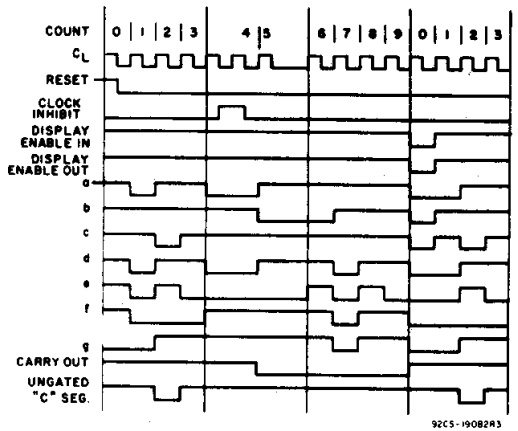

Fig. 3 - CD4026B timing diagram.

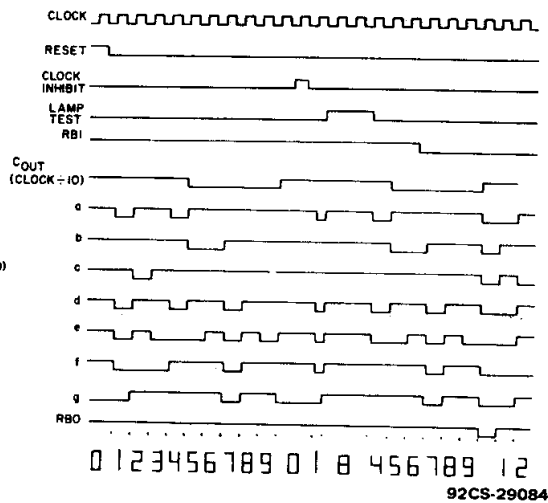

Fig. 4 - CD4033B timing diagram.

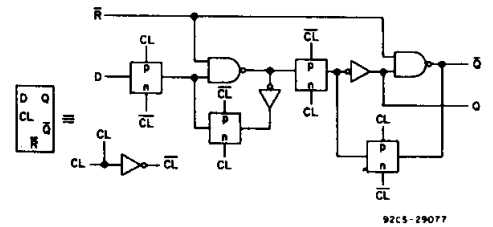

Fig. 5 - Detail of typical flip-flop stage for both types.

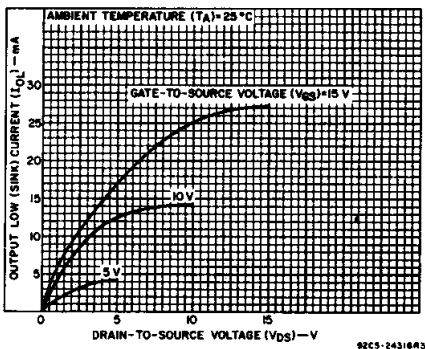

Fig. 6 - Typical n-channel output low (sink) current characteristics.

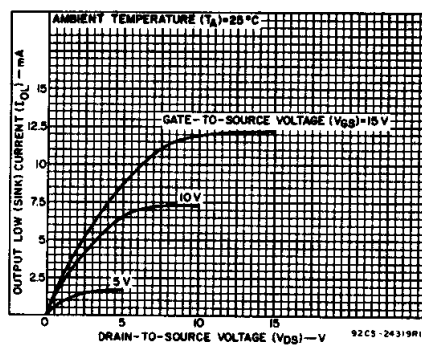

Fig. 7 - Minimum n-channel output low (sink) current characteristics.

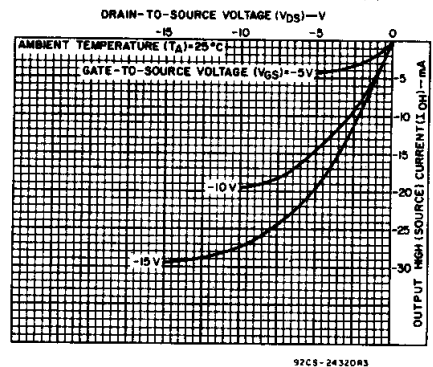

Fig. 8 - Typical p-channel output high (source) current characteristics.

# CD4026B, CD4033B Types

**DYNAMIC ELECTRICAL CHARACTERISTICS** at  $T_A = 25^\circ\text{C}$ , Input  $t_r, t_f = 20\text{ ns}$ ,  
 $C_L = 50\text{ pF}$ ,  $R_L = 200\text{ k}\Omega$

CHARACTERISTIC	TEST CONDITIONS	LIMITS			UNITS	
		VDD (V)	Min.	Typ.		Max.
<b>CLOCKED OPERATION</b>						
Propagation Delay Time; Carry-Out Line $t_{PLH}, t_{PHL}$		5	—	250	500	ns
		10	—	100	200	
		15	—	75	150	
Decode Outlines		5	—	350	700	ns
		10	—	125	250	
		15	—	90	180	
Transition Time; Carry-Out Line $t_{THL}, t_{TLH}$		5	—	100	200	ns
		10	—	50	100	
		15	—	25	50	
Maximum Clock Input Frequency, $f_{CL}^{\Delta}$		5	2.5	5	—	MHz
		10	5.5	11	—	
		15	8	16	—	
Min. Clock Pulse Width, $t_W$		5	—	110	220	ns
		10	—	50	100	
		15	—	40	80	
Clock and Clock Inhibit Rise or Fall Time; $t_{rCL}, t_{fCL}$		5	Unlimited		ns	
		10	Unlimited			
		15	Unlimited			
Average Input Capacitance, $C_{IN}$	Any Input	—	5	7	pF	
<b>RESET OPERATION</b>						
Propagation Delay Time; To Carry-Out Line, $t_{PLH}$		5	—	275	550	ns
		10	—	120	240	
		15	—	80	160	
To Decode Out Lines, $t_{PHL}, t_{PLH}$		5	—	300	600	ns
		10	—	125	250	
		15	—	90	180	
Min. Reset Pulse Width, $t_W$		5	—	100	120	ns
		10	—	50	100	
		15	—	25	50	
Min. Reset Removal Time		5	—	0	30	ns
		10	—	0	15	
		15	—	0	10	

$\Delta$  Measured with respect to carry-out line.

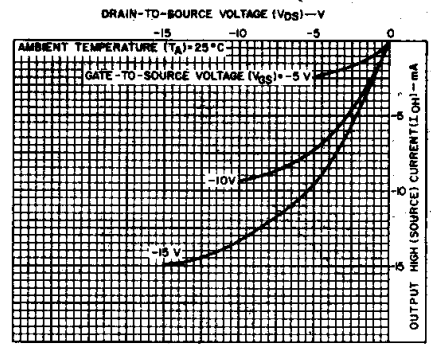

Fig. 9 — Minimum p-channel output high (source) current characteristics.

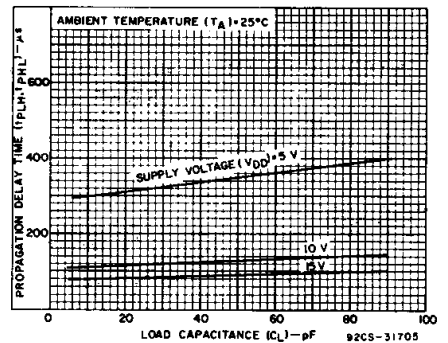

Fig. 10 — Typical propagation delay time as a function of load capacitance for decoded outputs.

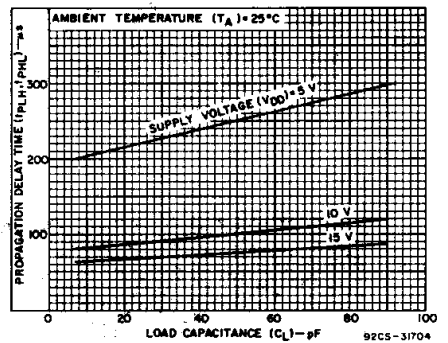

Fig. 11 — Typical propagation delay time as a function of load capacitance for carry-out outputs.

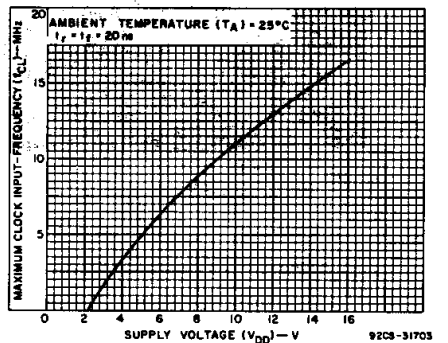

Fig. 12 — Typical maximum clock input frequency as a function of supply voltage.

3  
COMMERCIAL CMOS  
HIGH VOLTAGE ICs

# CD4026B, CD4033B Types

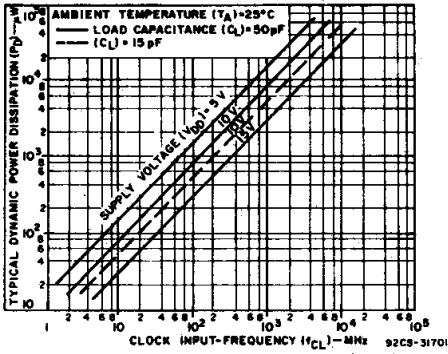

Fig. 13 - Typical power dissipation as a function of clock input frequency.

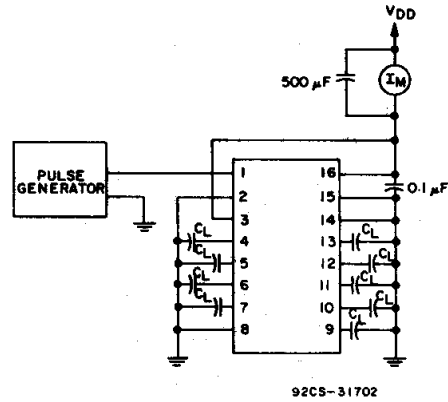

Fig. 14 - Dynamic power dissipation test circuit for CD4033B.

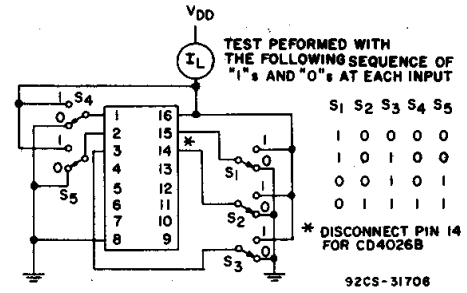

Fig. 15 - Quiescent device current.

## INTERFACING THE CD4026B AND CD4033B WITH COMMERCIALY AVAILABLE LIGHT EMITTING DIODE DISPLAYS

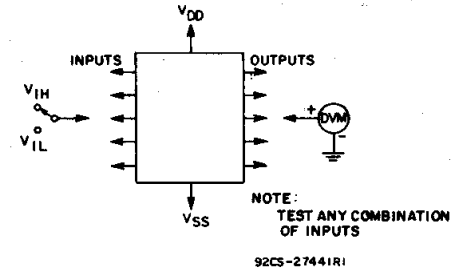
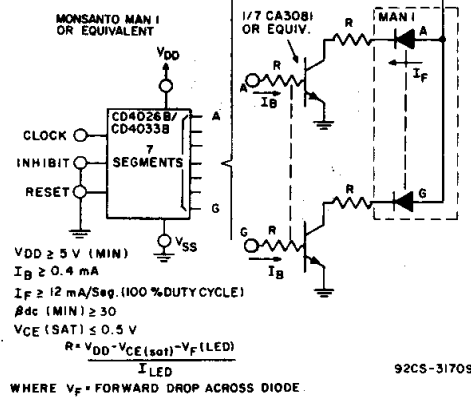
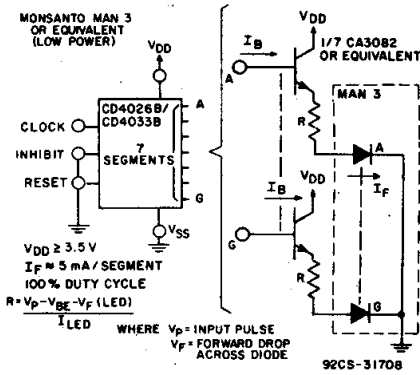

Fig. 16 - Input voltage.

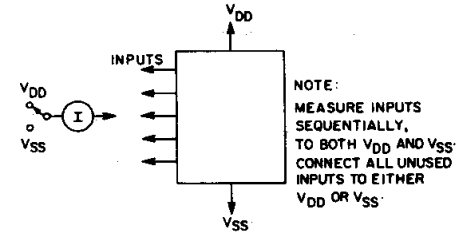
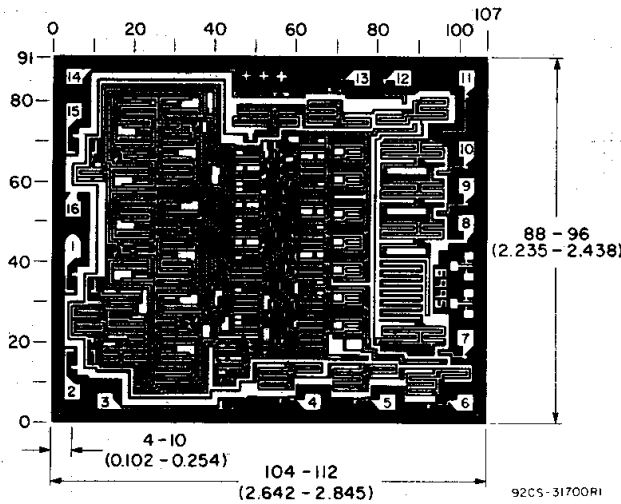
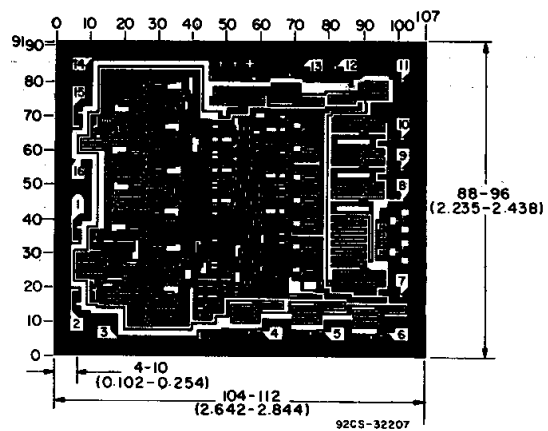

Fig. 17 - Input current.



Chip dimensions and pad layout for CD4026B

Dimensions in parentheses are in millimeters and are derived from the basic inch dimensions as indicated. Grid graduations are in mils (10<sup>-3</sup> inch).



Chip dimensions and pad layout for CD4033B

# CD4026B, CD4033B Types

## INTERFACING THE CD4026B AND CD4033B WITH COMMERCIALLY AVAILABLE 7-SEGMENT DISPLAY DEVICES\*

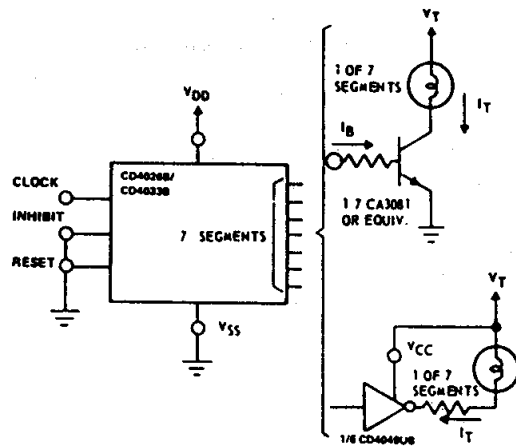

**INCANDESCENT READOUTS**  
 RCA Numitron DR2000 Series  
**TUBE REQUIREMENTS**  
 $V_T = 3.5-5V$   
 $I_T = 24 \text{ mA Segment}$

**ASSUMED TRANSISTOR CHARACTERISTICS** @  $V_{CC} = 10 \text{ V (min.)}$   
 $\beta_{dc} (\text{min.}) \geq 25$   
 $V_{CE(\text{sat.})} \leq 0.5 \text{ V}$   
 $V_{DD} = 8 \text{ V (min.)}$   
 $I_B = 1 \text{ mA (min.)}$   
 $I_T = 24 \text{ mA (min.)}$

**COMMON-EMITTER CHARACTERISTICS**  
 @  $V_{CC} = 10 \text{ V (min.)}$   
 $V_{CE} \leq 0.6 \text{ V}$   
 $I_T = 8 \text{ mA (min.)}$

### LOW-POWER INCANDESCENT READOUTS

PINLITES INC-Series O and R

TUBE REQUIREMENTS	$V_T$ (V)	mA/Segment
O-03-15	1.5	8
O-04-30	3	8
O-06-30	3	8
R-R3-20	2	4.3
R-R4-30	3	4.3

**ASSUMED TRANSISTOR CHARACTERISTICS**  
 $\beta_{dc} (\text{min.}) \geq 30$   
 $V_{CE(\text{sat.})} \leq 0.5 \text{ V}$   
 $V_{CC} \geq 3.5 \text{ V (min.)}$   
 $I_B \geq 0.25 \text{ mA (min.)}$   
 $I_T \leq 7.5 \text{ mA (min.)}$

92CM-31707

\* The interfacing buffers shown, while a necessity with the CD4026A and CD4033A, are not required when using the "B" devices; the "B" outputs ( $\approx 10$  times the "A" outputs) can drive most display devices directly especially at voltages above 10 V.

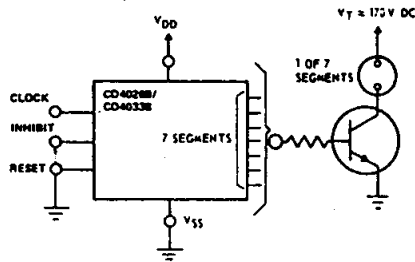

### NEON READOUT (NIXIE TUBE\*)

- Alco Electronics - MG19
- Burroughs - B5971, B7971, B8971

TUBE REQUIREMENTS	$V_T$ (Vdc)	mA Segment
Alco MG19	180	0.5
Burroughs B5971	170	3
Burroughs B7971, B8971	170	6

\* (Trademark) Burroughs Corp.

### TRANSISTOR CHARACTERISTICS

Leakage with transistor cutoff - 0.05 mA  
 $V_{(BR)CER} > V_T$   
 $\beta_{dc} (\text{min.}) \geq 30$

92CS-31710

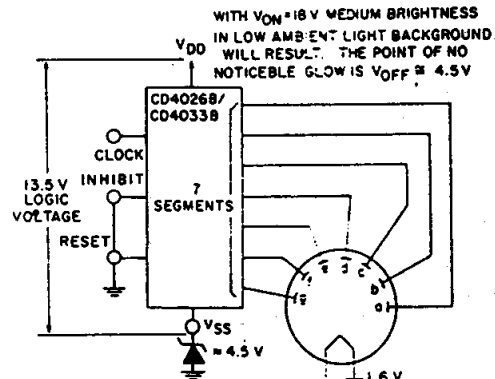

### LOW VOLTAGE VACUUM FLUORESCENT READOUTS

- Tung-Sol DIGIVAC S/G ; Type DT1704A or DT1705C
  - Nippon Electric (NEC); Type DG12E or LD91S
- TUBE REQUIREMENTS:** 100 to 300  $\mu\text{A}$ /segment at tube voltages of 12 V to 25 V depending on required brightness Filament requirement 45 mA at 1.6 V, ac or dc.

\* (Trademark) Wagner Electric Co.

92CS-31711

3  
 COMMERCIAL CMOS  
 HIGH VOLTAGE ICs

**PACKAGING INFORMATION**

Orderable part number	Status (1)	Material type (2)	Package   Pins	Package qty   Carrier	RoHS (3)	Lead finish/ Ball material (4)	MSL rating/ Peak reflow (5)	Op temp (°C)	Part marking (6)
<a href="#">CD4026BE</a>	Active	Production	PDIP (N)   16	25   TUBE	Yes	NIPDAU	N/A for Pkg Type	-55 to 125	CD4026BE
CD4026BE.A	Active	Production	PDIP (N)   16	25   TUBE	Yes	NIPDAU	N/A for Pkg Type	-55 to 125	CD4026BE
CD4026BEE4	Active	Production	PDIP (N)   16	25   TUBE	Yes	NIPDAU	N/A for Pkg Type	-55 to 125	CD4026BE
<a href="#">CD4026BNSR</a>	Active	Production	SOP (NS)   16	2000   LARGE T&R	Yes	NIPDAU	Level-1-260C-UNLIM	-55 to 125	CD4026B
CD4026BNSR.A	Active	Production	SOP (NS)   16	2000   LARGE T&R	Yes	NIPDAU	Level-1-260C-UNLIM	-55 to 125	CD4026B
<a href="#">CD4026BPW</a>	Obsolete	Production	TSSOP (PW)   16	-	-	Call TI	Call TI	-55 to 125	CM026B
<a href="#">CD4026BPWR</a>	Active	Production	TSSOP (PW)   16	2000   LARGE T&R	Yes	NIPDAU	Level-1-260C-UNLIM	-55 to 125	CM026B
CD4026BPWR.A	Active	Production	TSSOP (PW)   16	2000   LARGE T&R	Yes	NIPDAU	Level-1-260C-UNLIM	-55 to 125	CM026B
<a href="#">CD4033BE</a>	NRND	Production	PDIP (N)   16	25   TUBE	Yes	NIPDAU	N/A for Pkg Type	-55 to 125	CD4033BE
CD4033BE.A	NRND	Production	PDIP (N)   16	25   TUBE	Yes	NIPDAU	N/A for Pkg Type	-55 to 125	CD4033BE
<a href="#">CD4033BPW</a>	Obsolete	Production	TSSOP (PW)   16	-	-	Call TI	Call TI	-55 to 125	CM033B

(1) **Status:** For more details on status, see our [product life cycle](#).

(2) **Material type:** When designated, preproduction parts are prototypes/experimental devices, and are not yet approved or released for full production. Testing and final process, including without limitation quality assurance, reliability performance testing, and/or process qualification, may not yet be complete, and this item is subject to further changes or possible discontinuation. If available for ordering, purchases will be subject to an additional waiver at checkout, and are intended for early internal evaluation purposes only. These items are sold without warranties of any kind.

(3) **RoHS values:** Yes, No, RoHS Exempt. See the [TI RoHS Statement](#) for additional information and value definition.

(4) **Lead finish/Ball material:** Parts may have multiple material finish options. Finish options are separated by a vertical ruled line. Lead finish/Ball material values may wrap to two lines if the finish value exceeds the maximum column width.

(5) **MSL rating/Peak reflow:** The moisture sensitivity level ratings and peak solder (reflow) temperatures. In the event that a part has multiple moisture sensitivity ratings, only the lowest level per JEDEC standards is shown. Refer to the shipping label for the actual reflow temperature that will be used to mount the part to the printed circuit board.

(6) **Part marking:** There may be an additional marking, which relates to the logo, the lot trace code information, or the environmental category of the part.

Multiple part markings will be inside parentheses. Only one part marking contained in parentheses and separated by a "~" will appear on a part. If a line is indented then it is a continuation of the previous line and the two combined represent the entire part marking for that device.

**Important Information and Disclaimer:** The information provided on this page represents TI's knowledge and belief as of the date that it is provided. TI bases its knowledge and belief on information provided by third parties, and makes no representation or warranty as to the accuracy of such information. Efforts are underway to better integrate information from third parties. TI has taken and continues to take reasonable steps to provide representative and accurate information but may not have conducted destructive testing or chemical analysis on incoming materials and chemicals. TI and TI suppliers consider certain information to be proprietary, and thus CAS numbers and other limited information may not be available for release.

In no event shall TI's liability arising out of such information exceed the total purchase price of the TI part(s) at issue in this document sold by TI to Customer on an annual basis.

**TAPE AND REEL INFORMATION**

**QUADRANT ASSIGNMENTS FOR PIN 1 ORIENTATION IN TAPE**

\*All dimensions are nominal

Device	Package Type	Package Drawing	Pins	SPQ	Reel Diameter (mm)	Reel Width W1 (mm)	A0 (mm)	B0 (mm)	K0 (mm)	P1 (mm)	W (mm)	Pin1 Quadrant
CD4026BNSR	SOP	NS	16	2000	330.0	16.4	8.1	10.4	2.5	12.0	16.0	Q1
CD4026BPWR	TSSOP	PW	16	2000	330.0	12.4	6.9	5.6	1.6	8.0	12.0	Q1

**TAPE AND REEL BOX DIMENSIONS**



\*All dimensions are nominal

Device	Package Type	Package Drawing	Pins	SPQ	Length (mm)	Width (mm)	Height (mm)
CD4026BNSR	SOP	NS	16	2000	353.0	353.0	32.0
CD4026BPWR	TSSOP	PW	16	2000	353.0	353.0	32.0

**TUBE**

\*All dimensions are nominal

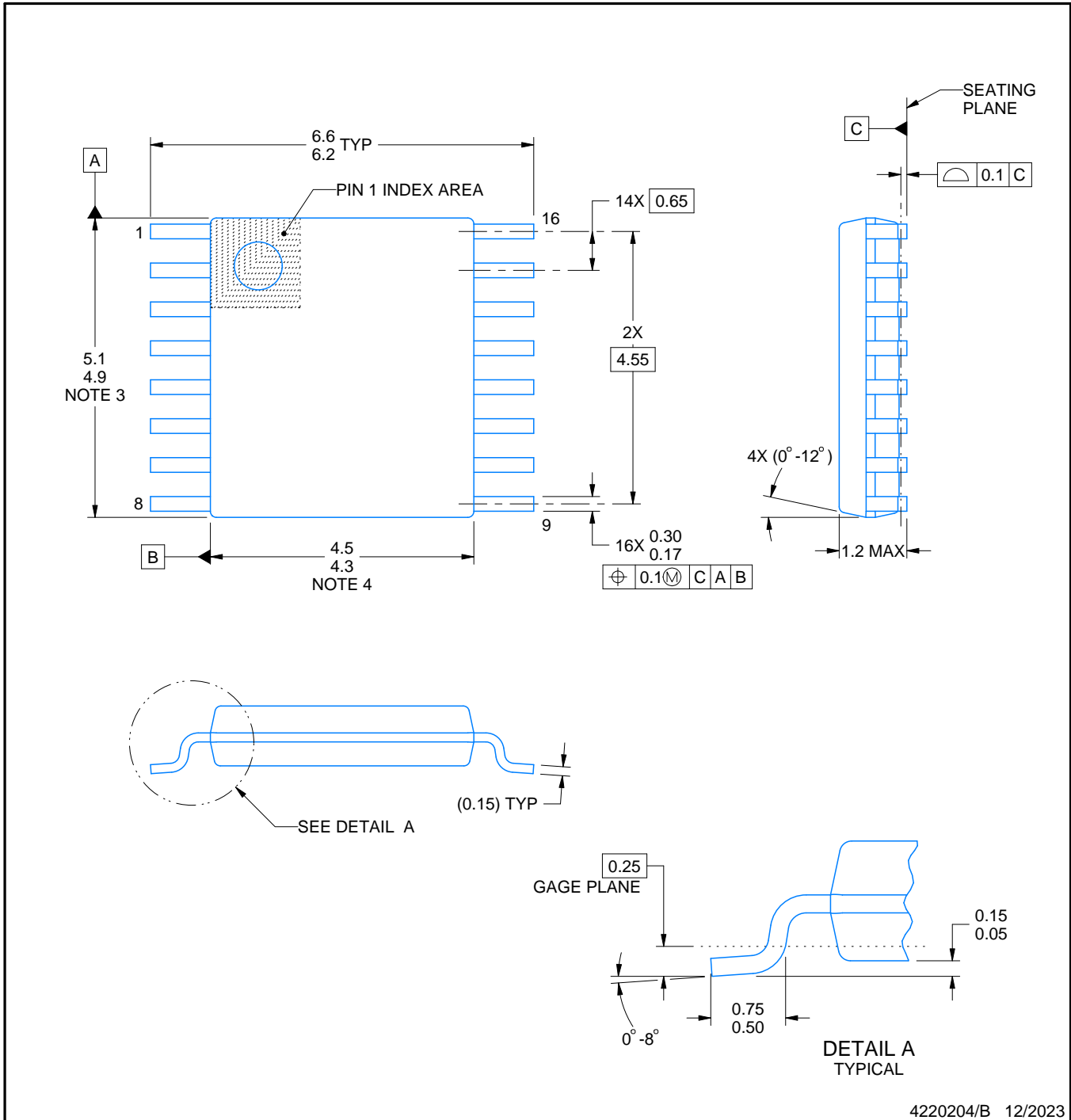
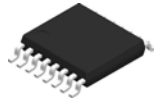
Device	Package Name	Package Type	Pins	SPQ	L (mm)	W (mm)	T (μm)	B (mm)
CD4026BE	N	PDIP	16	25	506	13.97	11230	4.32
CD4026BE	N	PDIP	16	25	506	13.97	11230	4.32
CD4026BE.A	N	PDIP	16	25	506	13.97	11230	4.32
CD4026BE.A	N	PDIP	16	25	506	13.97	11230	4.32
CD4026BEE4	N	PDIP	16	25	506	13.97	11230	4.32
CD4026BEE4	N	PDIP	16	25	506	13.97	11230	4.32
CD4033BE	N	PDIP	16	25	506	13.97	11230	4.32
CD4033BE	N	PDIP	16	25	506	13.97	11230	4.32
CD4033BE.A	N	PDIP	16	25	506	13.97	11230	4.32
CD4033BE.A	N	PDIP	16	25	506	13.97	11230	4.32



4220204/B 12/2023

NOTES:

1. All linear dimensions are in millimeters. Any dimensions in parenthesis are for reference only. Dimensioning and tolerancing per ASME Y14.5M.
2. This drawing is subject to change without notice.
3. This dimension does not include mold flash, protrusions, or gate burrs. Mold flash, protrusions, or gate burrs shall not exceed 0.15 mm per side.
4. This dimension does not include interlead flash. Interlead flash shall not exceed 0.25 mm per side.
5. Reference JEDEC registration MO-153.

# EXAMPLE BOARD LAYOUT

PW0016A

TSSOP - 1.2 mm max height

SMALL OUTLINE PACKAGE

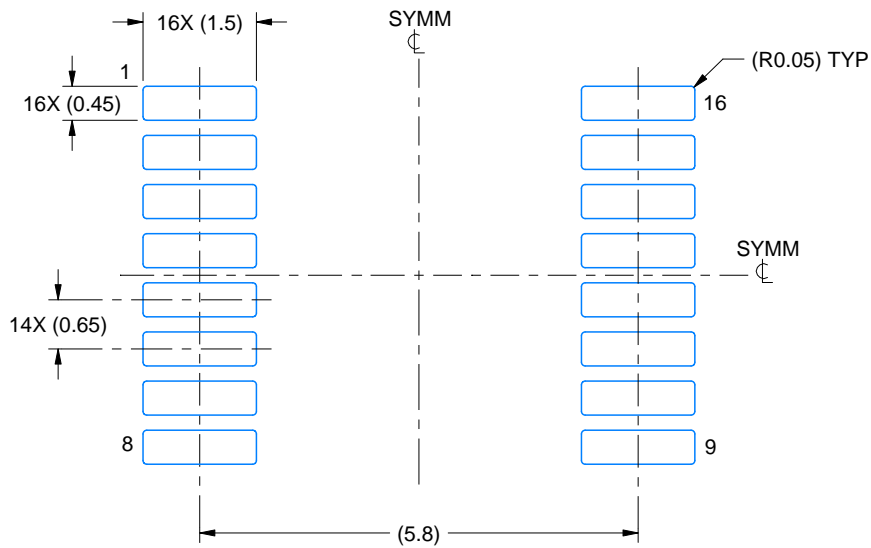

LAND PATTERN EXAMPLE  
EXPOSED METAL SHOWN  
SCALE: 10X

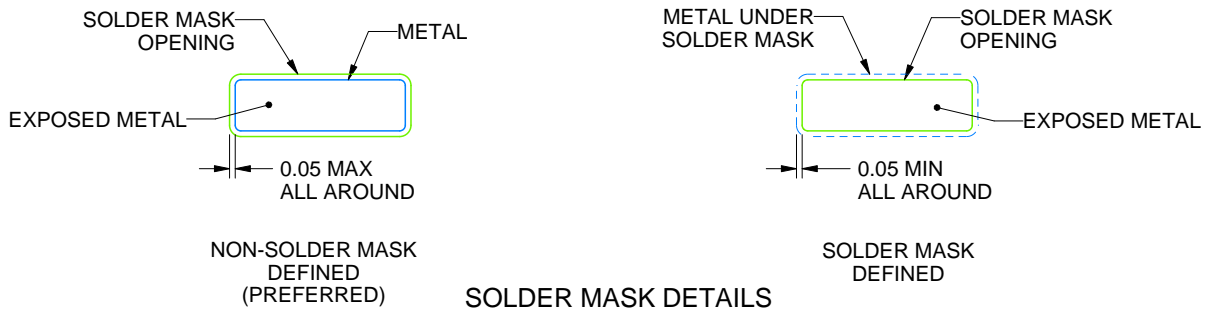

SOLDER MASK DETAILS

4220204/B 12/2023

NOTES: (continued)

- 6. Publication IPC-7351 may have alternate designs.
- 7. Solder mask tolerances between and around signal pads can vary based on board fabrication site.

# EXAMPLE STENCIL DESIGN

PW0016A

TSSOP - 1.2 mm max height

SMALL OUTLINE PACKAGE

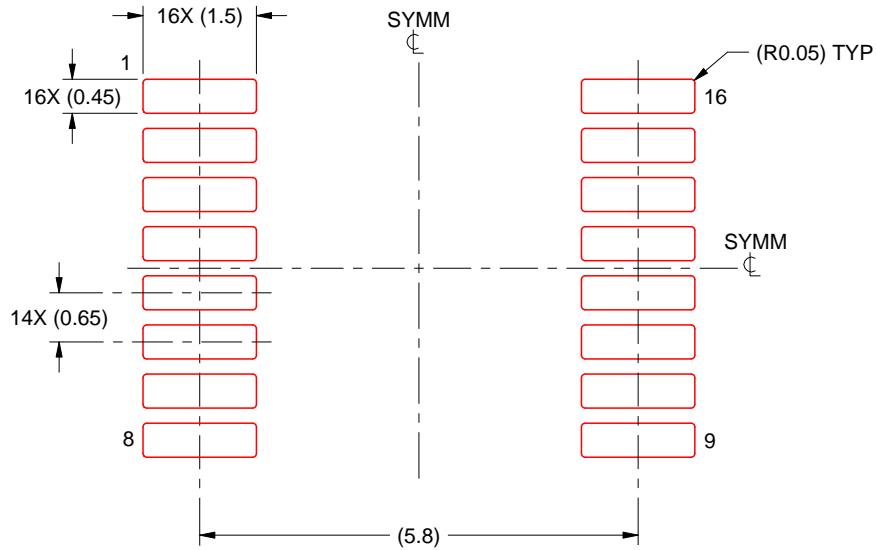

SOLDER PASTE EXAMPLE  
BASED ON 0.125 mm THICK STENCIL  
SCALE: 10X

4220204/B 12/2023

NOTES: (continued)

8. Laser cutting apertures with trapezoidal walls and rounded corners may offer better paste release. IPC-7525 may have alternate design recommendations.
9. Board assembly site may have different recommendations for stencil design.

N (R-PDIP-T\*\*)

PLASTIC DUAL-IN-LINE PACKAGE

16 PINS SHOWN



- NOTES:
- A. All linear dimensions are in inches (millimeters).
  - B. This drawing is subject to change without notice.
  - Falls within JEDEC MS-001, except 18 and 20 pin minimum body length (Dim A).
  - The 20 pin end lead shoulder width is a vendor option, either half or full width.



# PACKAGE OUTLINE

## NS0016A

### SOP - 2.00 mm max height

SOP



4220735/A 12/2021

#### NOTES:

1. All linear dimensions are in millimeters. Dimensions in parenthesis are for reference only. Dimensioning and tolerancing per ASME Y14.5M.
2. This drawing is subject to change without notice.
3. This dimension does not include mold flash, protrusions, or gate burrs. Mold flash, protrusions, or gate burrs shall not exceed 0.15 mm, per side.
4. This dimension does not include interlead flash. Interlead flash shall not exceed 0.25 mm, per side.

# EXAMPLE BOARD LAYOUT

NS0016A

SOP - 2.00 mm max height

SOP



4220735/A 12/2021

NOTES: (continued)

5. Publication IPC-7351 may have alternate designs.

6. Solder mask tolerances between and around signal pads can vary based on board fabrication site.

# EXAMPLE STENCIL DESIGN

NS0016A

SOP - 2.00 mm max height

SOP



SOLDER PASTE EXAMPLE  
BASED ON 0.125 mm THICK STENCIL  
SCALE:7X

4220735/A 12/2021

NOTES: (continued)

7. Laser cutting apertures with trapezoidal walls and rounded corners may offer better paste release. IPC-7525 may have alternate design recommendations.
8. Board assembly site may have different recommendations for stencil design.

## IMPORTANT NOTICE AND DISCLAIMER

TI PROVIDES TECHNICAL AND RELIABILITY DATA (INCLUDING DATASHEETS), DESIGN RESOURCES (INCLUDING REFERENCE DESIGNS), APPLICATION OR OTHER DESIGN ADVICE, WEB TOOLS, SAFETY INFORMATION, AND OTHER RESOURCES "AS IS" AND WITH ALL FAULTS, AND DISCLAIMS ALL WARRANTIES, EXPRESS AND IMPLIED, INCLUDING WITHOUT LIMITATION ANY IMPLIED WARRANTIES OF MERCHANTABILITY, FITNESS FOR A PARTICULAR PURPOSE OR NON-INFRINGEMENT OF THIRD PARTY INTELLECTUAL PROPERTY RIGHTS.

These resources are intended for skilled developers designing with TI products. You are solely responsible for (1) selecting the appropriate TI products for your application, (2) designing, validating and testing your application, and (3) ensuring your application meets applicable standards, and any other safety, security, regulatory or other requirements.

These resources are subject to change without notice. TI grants you permission to use these resources only for development of an application that uses the TI products described in the resource. Other reproduction and display of these resources is prohibited. No license is granted to any other TI intellectual property right or to any third party intellectual property right. TI disclaims responsibility for, and you fully indemnify TI and its representatives against any claims, damages, costs, losses, and liabilities arising out of your use of these resources.

TI's products are provided subject to [TI's Terms of Sale](#), [TI's General Quality Guidelines](#), or other applicable terms available either on [ti.com](#) or provided in conjunction with such TI products. TI's provision of these resources does not expand or otherwise alter TI's applicable warranties or warranty disclaimers for TI products. Unless TI explicitly designates a product as custom or customer-specified, TI products are standard, catalog, general purpose devices.

TI objects to and rejects any additional or different terms you may propose.

Copyright © 2026, Texas Instruments Incorporated

Last updated 10/2025